



# Installation Instructions



## Part # 11500298 - 2010 Up Camaro Air System

**Front Components:**  
 11302401 Front ShockWave Strut Instructions

**Rear Components:**  
 11505401 Rear ShockWave Instructions

### Recommended Tools



## 2010 up Camaro Air System Installation Instructions

**Table of contents**

Pages 2-9..... Front ShockWave  
 Pages 9-13..... Rear ShockWave



**Part # 11502401 -2010 up Camaro**

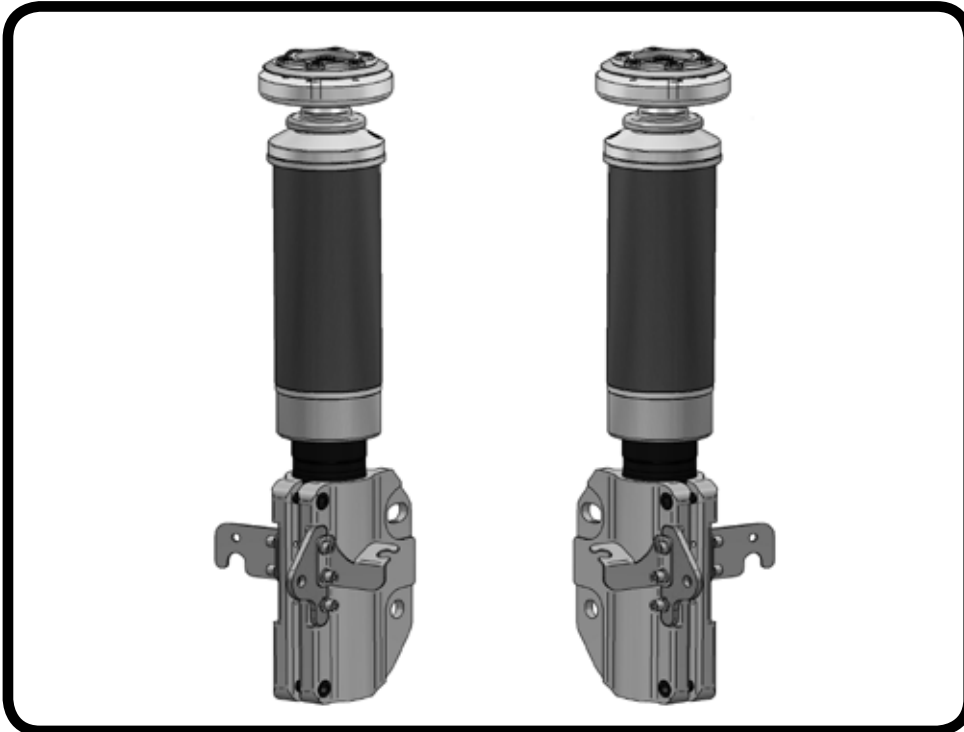

Recommended Tools

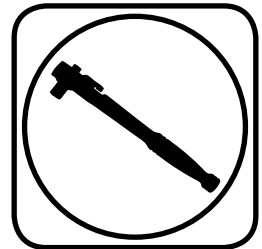

## 2010-up Camaro Front AirStrut Installation Instructions

### Table of contents

- Page 2..... Included components
- Page 3..... Disassembly and Getting Started
- Page 4-6..... Assembly
- Page 7..... Final Assembly
- Page 8..... Strut Adjustment



### Included Components .....In the box

Item #	Part #	Description	QTY
1	27569999	Strut Cartridge	2
2	90002367	Bearing Retaining Plate	2
3	90002363	Upper Retention Plate	2
4	70010941	Strut Extrusion	2
5	90002368	Thrust Bearing Adapter	2
6	70010987	Thrust Bearing	2
7	70010988	Thrust Bearing Washer	4
8	90001042	COM Bearing	2
9	90000805	COM Bearing Snap Ring	2
10	99562003	9/16"-18 Nylok Jam Nut	2
11	99251007	1/4"-20 x 1/4" SHCS	6
12	99251010	1/4"-20 x 1" SHCS	6
13	70010992	Strut Retaining Ring	2
14	99055000	M5 x.8 x 5mm Set Screw	2
15	70008913	Locking Ring	2
16	70010991	ABS Line Tab	2
17	70010990	Driver Brake Line Tab	1
17	70011386	Pass Brake Line Tab	1
18	70010975	Sway Bar Link Mount	2
19	99371042	3/8"-16 x 1" SHCS	4
20	99251008	1/4"-20 x 1/2" SHCS	4
21	99251009	1/4"-20 x 3/4" SHCS	6
22	99253007	1/4" Split Lock Washer	10
23	21090798	Strut Air Spring	2
24	70012986	Strut Spacer Shim	4
	90002376	Posilink Spacer (Not Shown)	2
	90002571	10mm 90 Degree PosiLink	4
	90002157	T-bushing-Posilink to sway bar	4
	31954201	1/4" 90 Degree Fitting	2

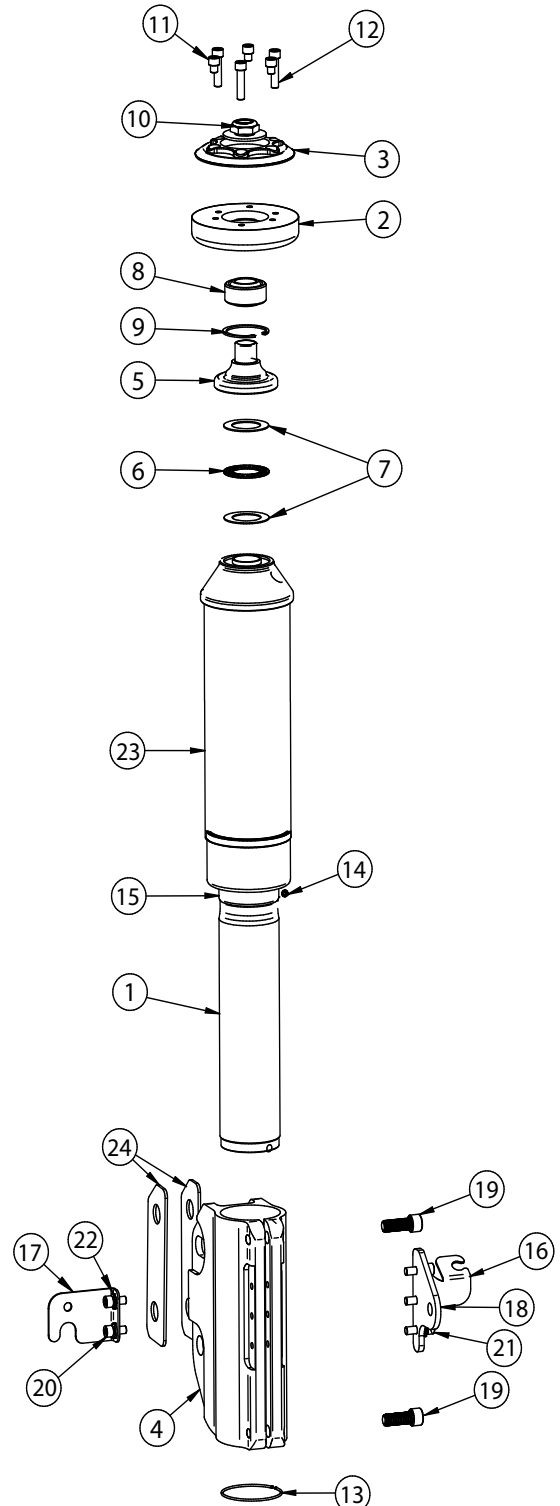



### Disassembly

1. Remove the front struts by first disconnecting the ABS wire and brake line(retain hardware) from the factory strut.
2. Disconnect the swaybar linkage from the strut.
3. Support the front hub and control arm assembly and remove the (2) struts bolts(retain hardware) that attach the strut to the spindle.
4. Remove the cap from the top strut nut in the engine compartment, then remove the nut and strut retainer. **DO NOT REMOVE THE SECOND NUT.**
5. Remove strut assembly from the car.

### Getting Started

6.

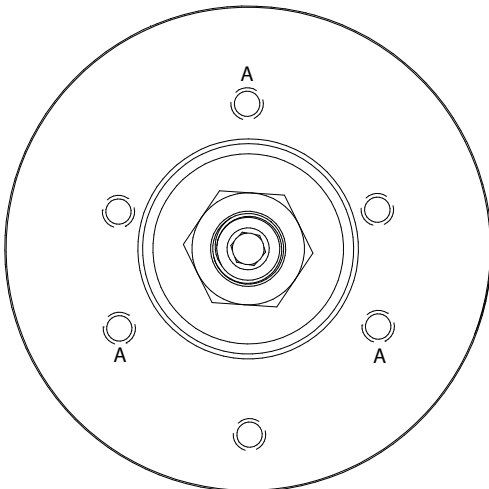

6. The upper strut mount provided in this kit has 2 mounting positions. Centered and offset. Looking at the illustration you will notice "A" bolt holes are centered and "B" bolt holes are offset. Position "A" is used for a street driving alignment. Position "B" is used when a more aggressive alignment is desired. This adjustable upper mount along with the adjustment on the lower Strut mount provide more adjustment than the stock setup. Position "B" will offset the top of the Strut towards the engine.

7.

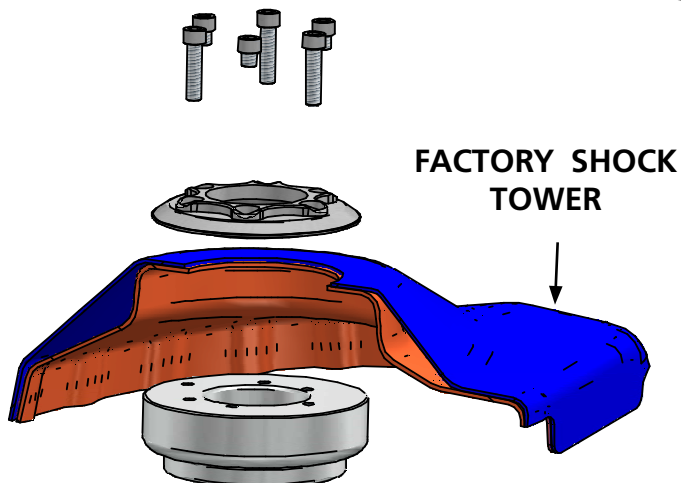

7. Bolt the upper mount into the car positioning it for the alignment desired using the description in the previous step. The mount will be either centered or the center strut mount offset towards the engine. The upper plate has (6) holes. (3) are threaded and (3) are thru drilled. The long bolts go thru the upper mount to attach it to the lower mount. The short bolts thread into the threaded holes. Tighten all (6) down.



### Strut Installation

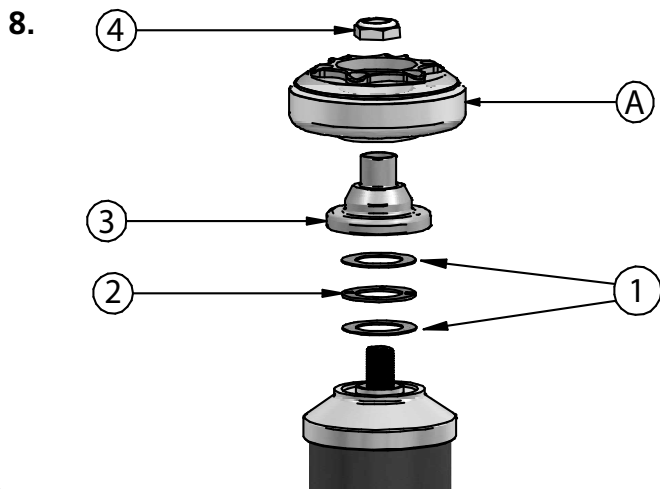

8. Install the Air fitting into the Airspring using thread tape. Remove the Adjuster Knob from the Strut shaft for assembly. Bolt the strut assembly into the upper mount (A), see diagram 10 for assembly order.

- 1. Torrington Bearing Race
- 2. Torrington Bearing
- 3. Torrington to Bearing Adapter
- 4. 9/16" Locknut

Assemble components and install into upper mount tightening upper nut. Reinstall upper adjustment knob. Skip to Step 12.

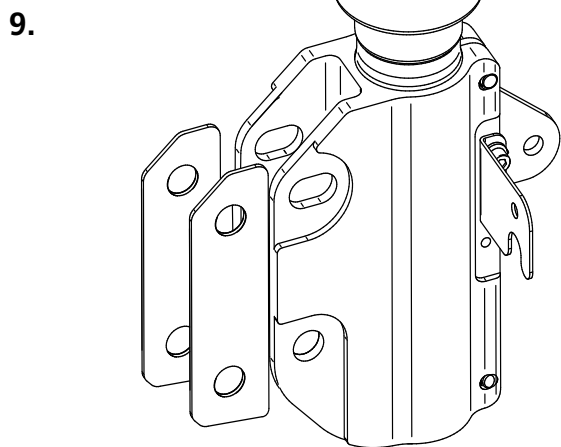

9. Slide the lower strut mount onto the spindle. Insert a Shim Spacer between the Spindle and Extrusion on each side of the Spindle. Align the all of the bolt holes, insert the Factory hardware to attach.

**NOTE:** These bolts are torque-to-yield bolts. They only have a few adjustments in them before they should be replaced. Tighten the bolt to 60 ft/lbs and turn the nut 180°.

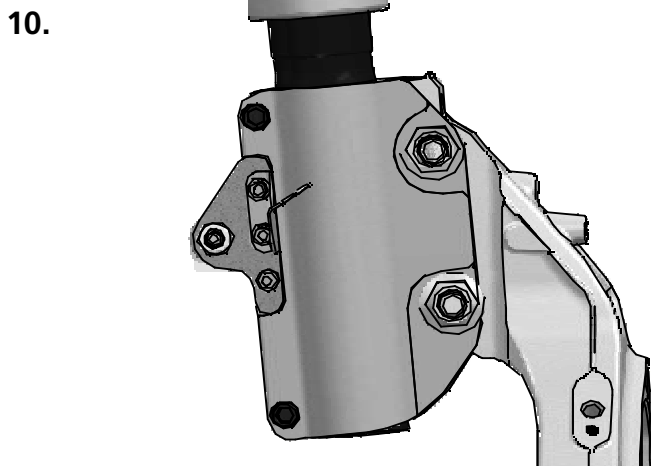

10. The Kit includes 4 shims. A shim will need to be placed on each side of the spindle, between the spindle and each ear of the strut mount.



### Assembly

11.

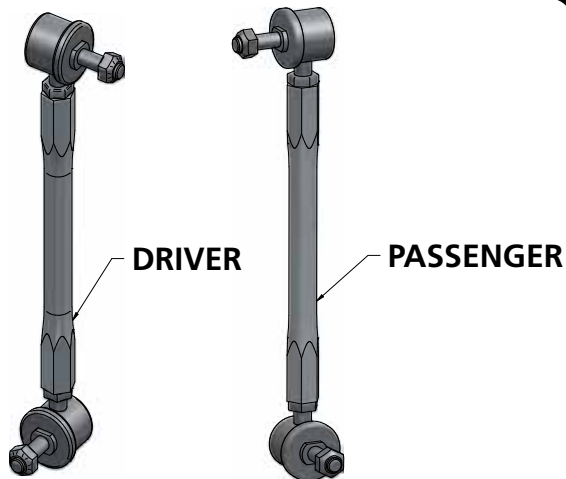

11. Attach the PosiLinks between the strut and Sway bar using the 10mm Nylok Nut. Refer to **Images 11 & 12** for orientation.

**NOTE:** There is a **Drivers** and **Passenger** Posilink assembly, refer to diagrams (11 and 12) for proper installation

**NOTE:** Some vehicles have a 10mm sway bar linkage, some have 12mm linkage. The Posilink linkage provided in the kit has 10mm studs, T-bushings are provided in the kit for 12mm linkage setups. Install a T-bushing in each side of the swaybar hole, then install the Posilink in it and tighten.

12.

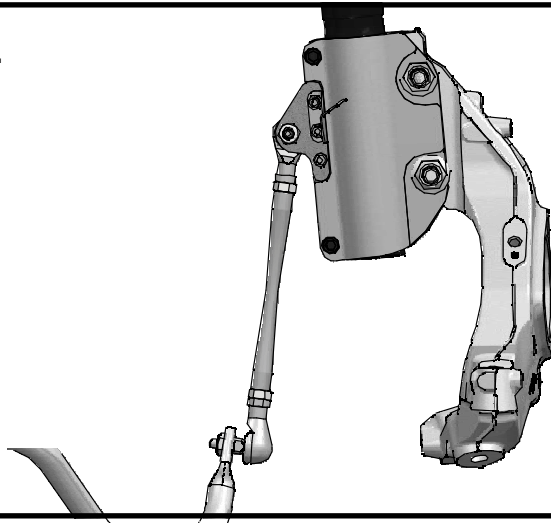

12. The PosiLink mounts with the stud on the Strut pointing forward, and the stud on the Sway bar pointing in.

**Note:** Image is viewing from front of vehicle.

**Note:** Depending on the manufacture of the swaybar on your car, you may have to flip the PosiLink assembly to get the best fit. The PosiLink needs to be as straight as possible with the steering wheel straight.

13.



13. Attach the brake line to the mount on the Strut using the Factory hardware.



### Final Assembly



**14.** Slide the ABS wire into its mount on the Strut.

**15.** Route the Airline to the Air Spring. When hooking up the Airline be sure that you can turn the steering from lock to lock with out tugging on the Airline. This situation will eventually cause the line to leak.

**16.** Repeat previous steps on Passenger side.



### Strut Adjustment

#### Strut Adjustment 101- Single Adjustable

##### Rebound Adjustment:

How to adjust your new struts.

The rebound adjustment knob is located on the top of the Strut protruding through the upper mount.

You must first begin at the ZERO setting, then set the shock to a soft setting of 20.



-Begin with the Strut adjusted to the ZERO rebound position (full stiff). Do this by rotating the rebound adjuster knob clockwise until it stops.

-Now turn the rebound adjuster knob counter clock wise 20 clicks. This sets the shock at 20. (settings 21-24 are typically too soft for street use).

##### Take the vehicle for a test drive.



-If you are satisfied with the ride quality, do not do anything, you are set!

-If the ride quality is too soft increase the damping effect by rotating the rebound knob clock wise 3 clicks.

##### Take the vehicle for another test drive.



-If the vehicle is too soft increase the damping effect by rotating the rebound knob clock wise 3 additional clicks.

-If the vehicle is too stiff rotate the rebound adjustment knob counter clock wise 2 clicks and you are set!

Take the vehicle for another test drive and repeat the above steps until the ride quality is satisfactory.

##### Note:

**One end of the vehicle will likely reach the desired setting before the other end. If this happens stop adjusting the satisfied end and keep adjusting the unsatisfied end until the overall ride quality is satisfactory.**





**Part # 11505410 -2010 up Camaro**

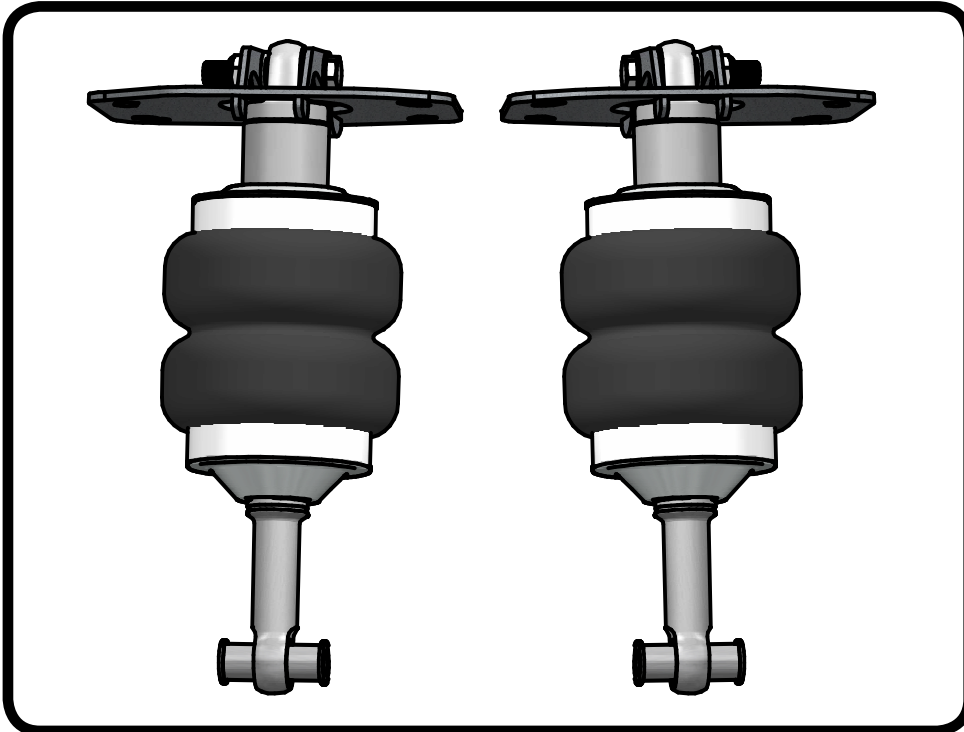

Recommended Tools

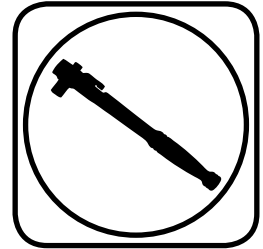

## 2010-up Camaro Rear Shockwave System Installation Instructions

### Table of contents

- Page 10..... Included components
- Page 11..... Disassembly and Assembly
- Page 12..... Final Assembly
- Page 13..... Shock Adjustment



### Included Components .....In the box

Item #	Part #	Description	QTY
1	24139999	3.6" Stroke HQ Series Shock	2
2	90002025	Shock Eyelet	2
3	90002382	Driver Upper ShockWave Mount	1
3	90002383	Passenger Upper ShockWave Mount	1
4	24190199	1000 Series ShockWave Bellow	2
5	90002043	Upper 1/2" ID Shock Spacer (NARROW)	4
6	90002381	Lower 1/2" ID Shock Spacer (WIDE)	4
	70008913	Bellow Locking Ring (Installed in ShockWave)	2
	99055000	Locking Ring Set Screw (Installed in ShockWave)	2
	31954201	1/4" tube to 1/4" NPT 90 degree Airline fitting	2
	90001994	5/8" ID Bearing (installed in shock and eyelet)	4
	90001995	Bearing Snap Ring (installed in shock and eyelet)	8
12	99501011	1/2-20 x 2 1/2" Hex Bolt	2
13	99503001	1/2" SAE Flatwasher	4
14	99502008	1/2"-20 Hex Nut	2

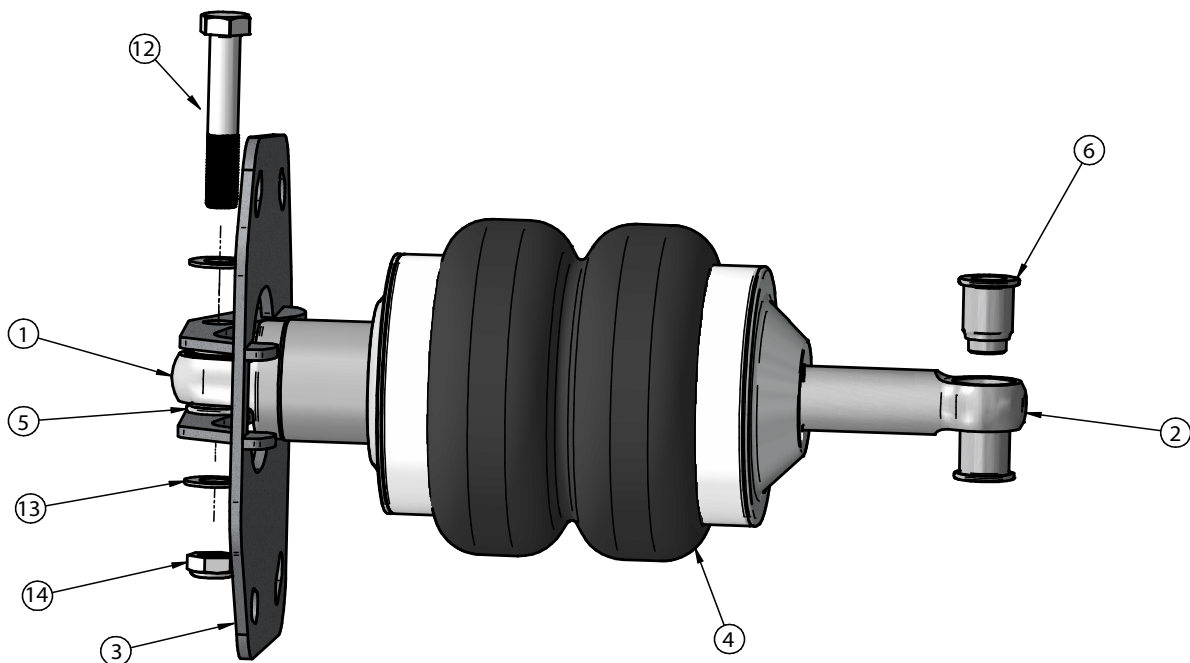



### Disassembly

1. Raise the vehicle off the ground and safely support it by something other than the suspension.
2. Disconnect the swaybar linkage from the lower Control Arm.
3. Remove the Bolt attaching the OEM Shock setup from the lower control arm and retain it for reassembly.
4. Remove the (4) bolts attaching the upper shock mount. **Retain the Bolts for reassembly,**
5. Remove the bolt that attaches the Spindle to the lower control arm.
6. Swing the lower control arm down and remove the OEM Shock setup.

### Assembly

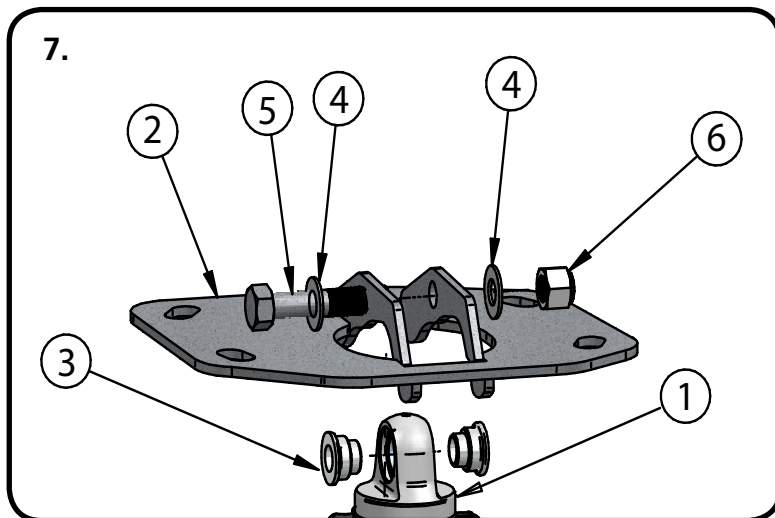

7. Install the Airfitting into the Shockwave using Teflon Tape. Install the shock body side of the ShockWave(1) into the upper mount(2) using a (90002403) spacer(3) installed into the bearing. With the spacers installed into the shock bearing, insert the ShockWave into the mount aligning the holes in the mount with the thru hole in the bearing spacers. Install a 1/2" Flatwasher(4) on the 1/2 x 2 1/2" Hex bolt(5) and insert in the aligned holes. Finish by installing a 1/2" Flatwasher(4) and 1/2" Nylok nut(6) and tightening the nut/bolt.



8. Install the ShockWave/Upper Mount assembly into the car using the factory hardware. There is a Driver and Passenger upper bracket. These brackets are marked accordingly. Once the assembly is installed in the car, rotate the shock eyelet so that the adjuster knob is towards the outside of the car.

**Note:** You will have to swing the lower arm down to get the assembly into the car.



### Assembly

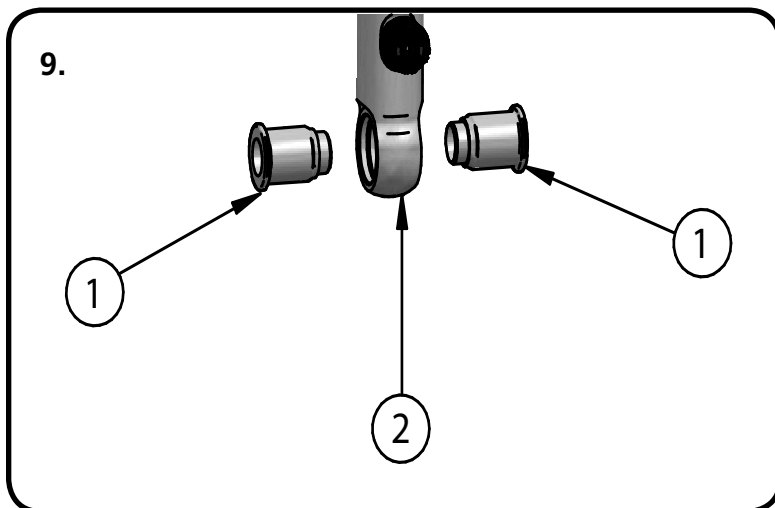

9. Install the (90002381) spacers(1) into the bearing in the ShockWave eyelet(2). Align the ShockWave eyelet with the factory mounting hole and reinstall the factory hardware and tighten.

### Final Assembly

10. Reassemble car by reinstalling lower Control arm bolt through spindle and reattaching swaybar linkage to lower control arm and tightening hardware.

11. Repeat the previous steps on the other side.

12. Hook up the Airlines to the ShockWaves. The Air fitting can be clocked by grabbing the Airspring with your hands and rotating it on the shock.



### Strut Adjustment

#### Shock adjustment 101- Single Adjustable

##### Rebound Adjustment:

How to adjust your new shocks.

The rebound adjustment knob is located on the top of the shock absorber protruding from the eyelet.

You must first begin at the ZERO setting, then set the shock to a soft setting of 20.



-Begin with the shocks adjusted to the ZERO rebound position (full stiff). Do this by rotating the rebound adjuster knob clockwise until it stops.



-Now turn the rebound adjuster knob counter clock wise 20 clicks. This sets the shock at 20. (settings 21-24 are typically too soft for street use).

##### Take the vehicle for a test drive.



-If you are satisfied with the ride quality, do not do anything, you are set!



-If the ride quality is too soft increase the damping effect by rotating the rebound knob clock wise 3 clicks.

##### Take the vehicle for another test drive.



-If the vehicle is too soft increase the damping effect by rotating the rebound knob clock wise 3 additional clicks.



-If the vehicle is too stiff rotate the rebound adjustment knob counter clock wise 2 clicks and you are set!

Take the vehicle for another test drive and repeat the above steps until the ride quality is satisfactory.

##### Note:

**One end of the vehicle will likely reach the desired setting before the other end. If this happens stop adjusting the satisfied end and keep adjusting the unsatisfied end until the overall ride quality is satisfactory.**