



Part # 11390297 - 82-03 GM S10/S15 ShockWave System

Front Components:

11399959	Front TruTurn Control Arm System
11393001	Front ShockWave
11399120	Front MuscleBar

Rear Components:

11397199	Rear StrongArm System
21150701	Rear ShockWave Instructions

Recommended Tools

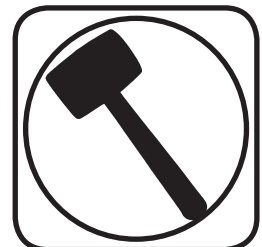
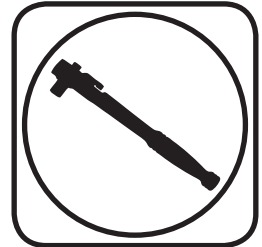

82-03 S10/S15 ShockWave System Installation Instructions

Table of contents

Pages 2-6.....	Front ShockWaves
Pages 7-17.....	Front TruTurn Control Arm System
Pages 18-20.....	Front MuscleBar
Pages 21-34.....	Rear Wishbone Kit
Pages 35-36.....	Rear ShockWaves
Pages 37-38.....	Care of your ShockWaves and Adjusting



Part # 11393001 - 82-03 GM S10 Front HQ Series Shockwave

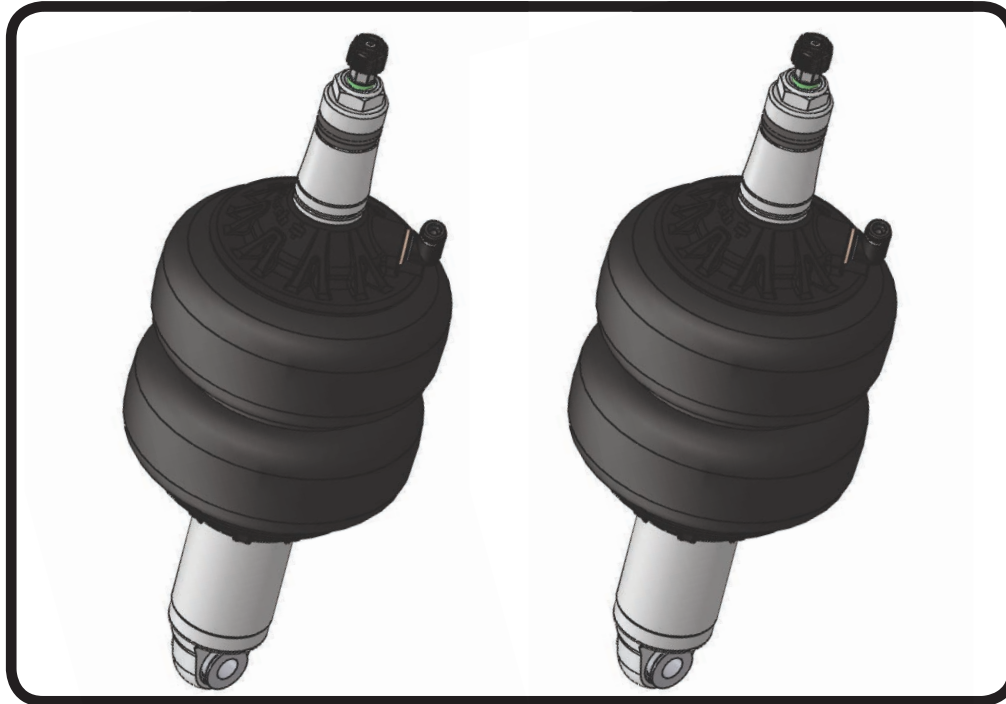

Recommended Tools

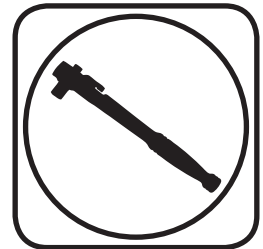

1000 Series Bellow, 2.00" Stud/Eye 3.6" Shock Installation Instructions

Table of contents

Page 3..... Included components

Page 4-5..... Shockwave Installation

Page 6..... Notes and Care of Your Shockwave & Shock Adjustment

ShockWave Dimensions:

Center of bearing to Center of bearing:

Compressed: 10.30"

Ride Height: 12.13"

Extended: 13.32"

THE DELRIN BALL REQUIRES A 3/4" HOLE FOR THE FLANGE TO GO THROUGH. THIS CAN BE DRILLED WITH A UNIBIT.



Major ComponentsIn the box

Item #	Part #	Description	QTY
1	24139999	3.6" Stroke HQ Series Shock	2
2	90009988	2.00" Stud Top (Installed on Shock) - Includes Adjuster Knob & Screw	2
3	24090199	1000 Series 6.5" Double Convoluted AirSpring	2
4	70010893	AirSpring Locking Ring (Installed on shock)	2
5	99055000	Locking Ring Set Screw (Installed on shock)	2
6	90002062	Spacers - INCLUDED WITH STRONGARMS	4
7	90002312	2.00" Aluminum Stud Top Base	2
8	90001904	Bottom Delrin Ball	2
9	90001903	Top Delrin Ball	2
10	90001902	Delrin Ball Aluminum Top Cap	2
11	99562003	9/16" -18 Thin Nylok Nut	2
12	90009972	Adjuster Knob - (90009988 assembly)	2
13	90009969	#4-40 X 1/4" SS, 18-8 Pan Head Torx Cap - (90009988 assembly)	2
	70012160	2.00" Stud Top Metering Rod (installed in stud top)	2
	90001994	5/8" ID Bearing (installed in shock and eyelet)	4
	90001995	Bearing Snap Ring (installed in shock and eyelet)	8

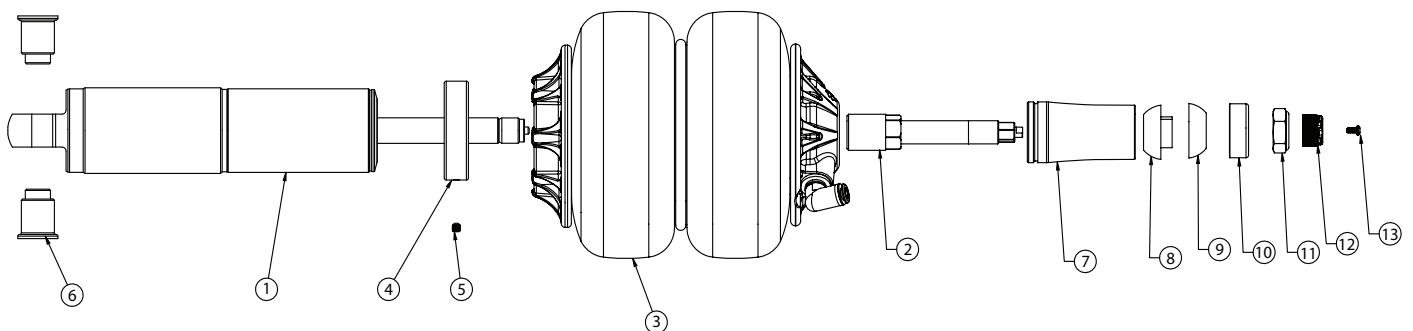

THE DELRIN BALL REQUIRES A 3/4" HOLE FOR THE FLANGE TO GO THROUGH. THIS CAN BE DRILLED WITH A UNIBIT.

WARNING: ATTEMPTING TO REMOVE THE AIR FITTING WILL DAMAGE IT AND VOID THE WARRANTY.



ShockWave Installation

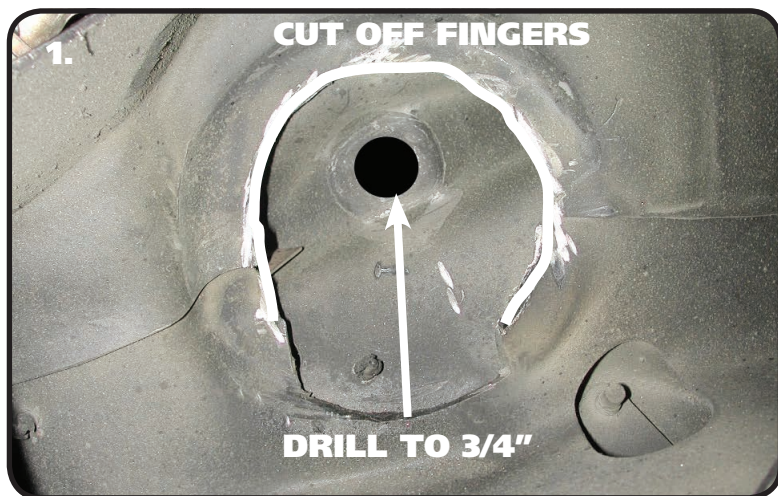

1. Drill the OEM shock hole out to 3/4". This can be done with a Unibit. The Shockwave top can come in contact with the coil spring retaining fingers. Test fit the ShockWave to determine if they need cut off. A die grinder works well here.



2. For air spring clearance some trimming must be done on the outer portion of the coil spring pocket. The amount of trimming necessary will vary from one car to another, it is best to install the Shockwave onto the lower arm and inflate the bellows. Check clearance throughout full suspension travel. **(Inflated diameter of this Shockwave is approximately 6.5")** This is best done with a cut off wheel or plasma cutter. Make the cuts round, square corners will create a fracture point.

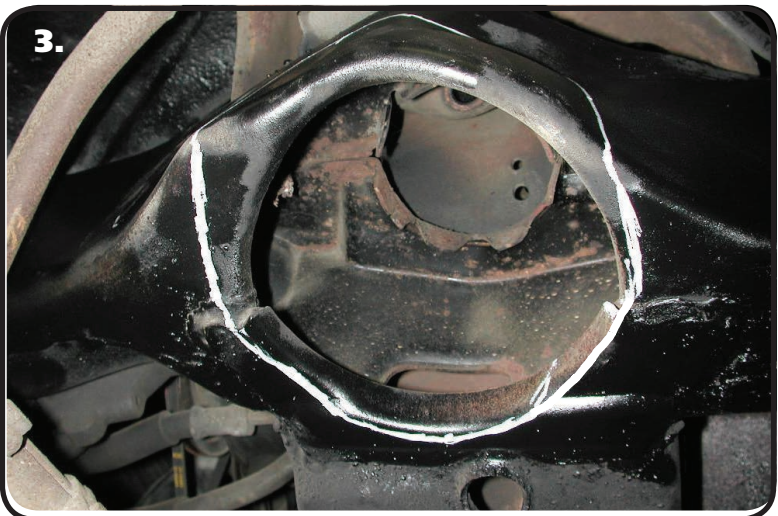

3. To allow clearance for the Shockwave, some trimming may need to be done on the inside of the coil spring pocket as shown by the white line in the picture. This is best done with either a cut off wheel or plasma cutter. Grind all cuts smooth when finished.

Note: It may be helpful to go ahead and install the lower StrongArms and Shockwaves to determine exactly what needs to be removed.



ShockWave Installation

4.

1. Stud top aluminum base
2. Delrin ball lower half
3. Delrin ball upper half
4. Aluminum cap
5. 9/16" SAE Nylok jam nut
6. Threaded stud (screwed onto shock shaft)
7. Rebound adjusting knob
8. Screw

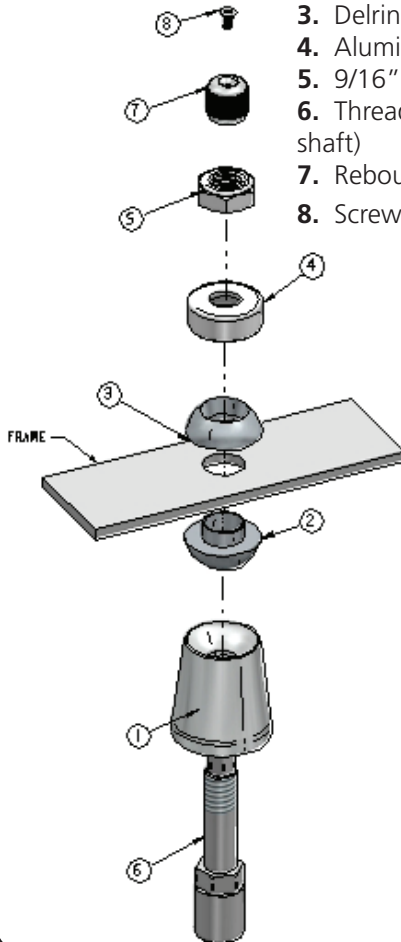

Note: The airline must also be routed at this time. It can be ran through the subframe toward the rear of the vehicle.

4. The air fitting location can be rotated by twisting the bellow assembly separate of the shock. Place the Shockwave into the coil spring pocket with the stud sticking through the OEM shock hole. See assembly **Diagram 4**. OEM Shock hole **must** be drilled out to $\frac{3}{4}$ "

1. Stud top aluminum base
2. Delrin ball lower half
3. Delrin ball upper half
4. Aluminum cap
5. 9/16" SAE Nylok jam nut
6. Threaded stud (screwed onto shock shaft)
7. Rebound adjusting knob
8. Screw

5.

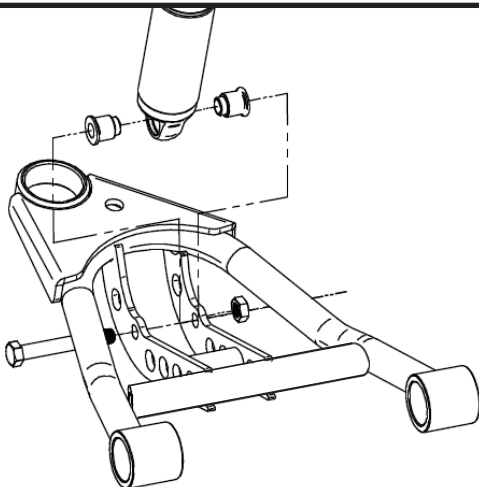

5. Raise the lower arm up to the Shockwave and bolt them together using the $\frac{1}{2}$ " x $3\frac{1}{4}$ " bolt and Nylok supplied w/ the lower arms. An aluminum spacer will be on each side of the bearing. Torque to 75 ftbs.

6. Raise the lower control arm to full compression and double-check to make sure the Shockwave does not rub on anything at anytime. Allowing the Shockwave to rub on anything will cause failure and is not a warrantable situation.

7. The best ride quality will occur around 50-60% suspension travel; depending on vehicle weight this typically occurs around 85-100 psi.



Notes and Care of your Shockwaves

4.

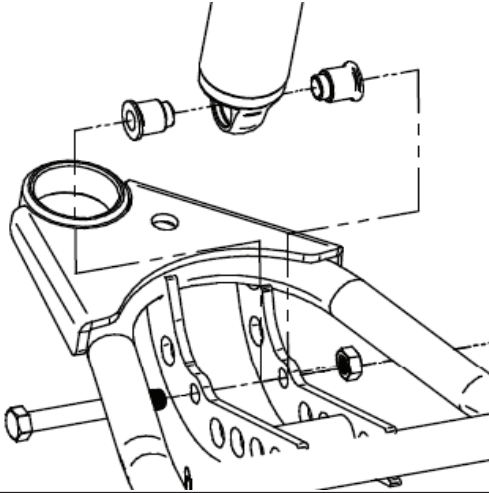

4. Install a spacer on each side of the lower CoilOver. Slide the shock with the spacers installed into the lower control arm. Raise the arm up to line up the holes in the bushing with the 1/2" hole in the control arm straps and hold it in place while you install the 1/2" x 3 1/2" bolt, 1/2" flat washer, and 1/2" Nylok nut. Tighten the upper and lower shock bolts.

Ride Height

We have designed most cars to have a ride height of about 1 1/2" lower than factory. To achieve the best ride quality & handling, the shock absorber needs to be at 40-60% overall travel when the car is at ride height. This will ensure that the shock will not bottom out or top out over even the largest bumps. Measuring the shock can be difficult, especially on some front suspensions. Measuring overall wheel travel is just as effective and can be much easier. Most cars will have 4-6" of overall wheel travel. One easy way to determine where you are at in wheel travel is to take a measurement from the fender lip (center of the wheel) to the ground. Then lift the car by the frame until the wheel is just touching the ground, re-measure. This will indicate how far you are from full extension of the shock. A minimum of 1.5" of extension travel (at the wheel) is needed to ensure that the shock does not top out. If you are more than 3" from full extension of the shock then you are in danger of bottoming out the shock absorber.

Adjusting Spring Height

When assembling the CoilOver, screw the spring retainer tight up to the spring (0 preload). After entire weight of car is on the wheels, jounce the suspension and roll the car forward and backward to alleviate suspension bind.

- If the car is too high w/ 0 preload then a smaller rate spring is required. Although threading the spring retainer down would lower the car, this could allow the spring to fall out of its seat when lifting the car by the frame.

- If the car is too low w/ 0 preload, then preload can then be added by threading the spring retainer up to achieve ride height. On 2.6" - 4" stroke shocks, up to 1.5" of preload is acceptable. On 5-7" stroke shocks, up to 2.5" of preload is acceptable. If more preload is needed to achieve ride height a stiffer spring rate is required. Too much preload may lead to coil bind, causing ride quality to suffer.



Part # 11399599 82-03 S10 Tru-Turn Suspension Package

Front Components:

1	11323699	Upper Strong Arms
1	11322899	Lower Strong Arms
1	11329500	Tru Turn System

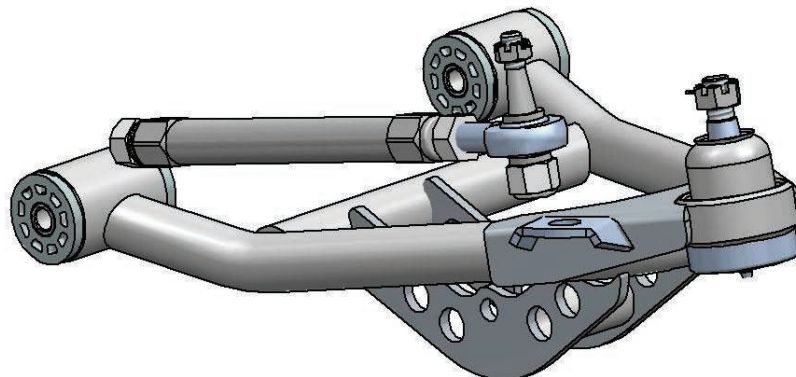
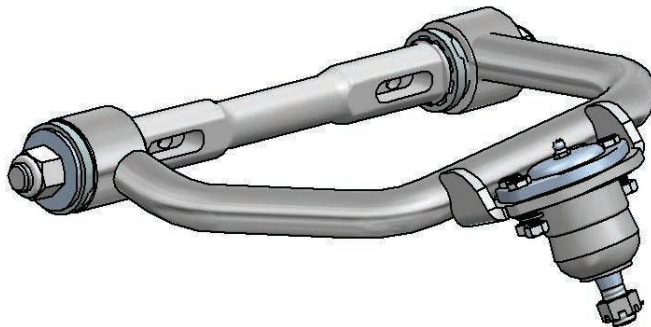



Upper StrongArm Installation

82-03 S10 Upper StrongArms

Components:

1	90002379	Drivers side arm
1	90002380	Passenger side arm
2	90000913	Upper ball joint
2	90000914	Caster Adjustable Cross shaft w/Hardware
2	70010826	Delrin Bushing – no ledge
2	70010827	Delrin Bushing – small ledge
4	70010759	Delrin Bushing – outer
4	70011955	Zero Offset Caster Slugs

Hardware:

4	99431009	7/16-14 x 2 ½” Hex Bolt	Cross shaft to Frame
4	99432001	7/16”-14 Nylok Nut	Cross shaft to Frame
4	99433002	7/16” SAE Flatwasher	Cross shaft to Frame



Upper StrongArm Installation



1. Fasten the upper arm to the frame using the supplied hardware. Reinstall the current alignment shims, but **vehicle must be realigned.**
2. Drop ball joint down through upper arm. Slide ball joint boot over stud, then place boot retainer over the boot. Clamp assembly tight w/ the hardware supplied.
3. Fasten the ball joint to the spindle w/ the new castle nut and cotter pin supplied.
4. Tighten the cross shaft nuts enough to create drag on the delrin bushings, the arm should still move.

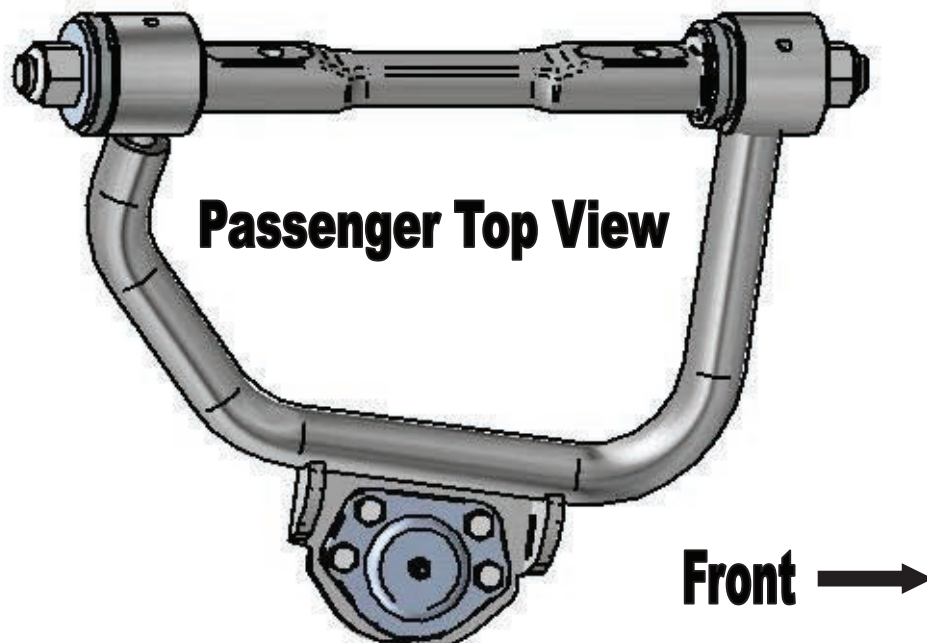



Upper StrongArm Installation

Passenger Side – Top View

Item #	Description	Qty.
1.	5/8 – 18 Toplock Jam Nut	4
2.	Outer Washer	4
3.	Outer Delrin bushing	4
4.	Passenger side arm	1
4.	Driver side arm	1
5.	Inner Delrin bushing w/ledge	2
6.	Caster Adjustable Cross shaft	2
7.	Caster Slug	2
8.	Inner Delrin bushing no ledge	2

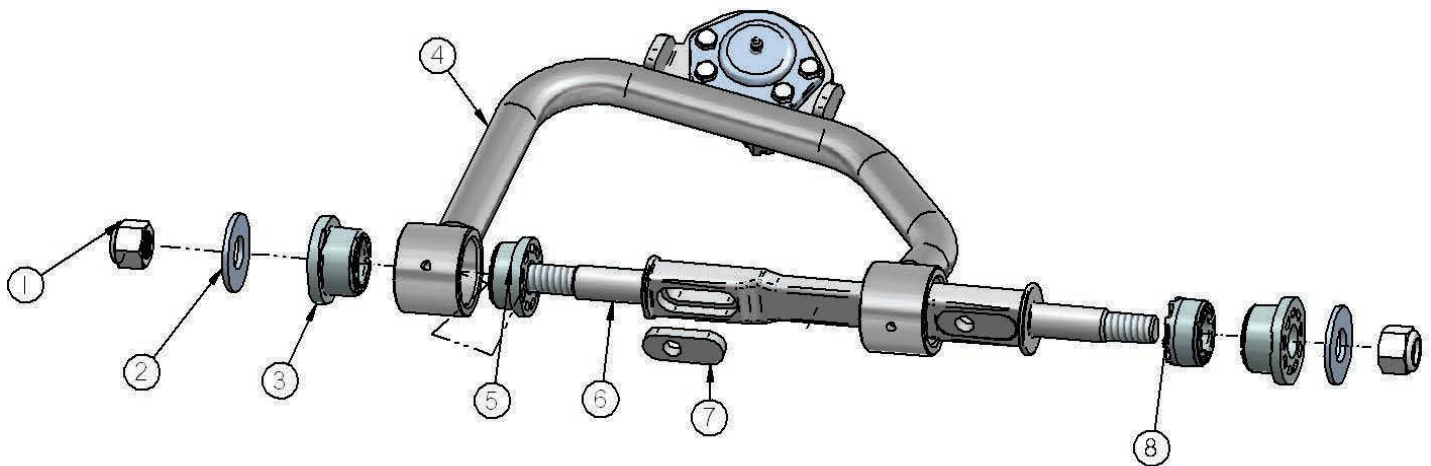



Upper StrongArm Installation

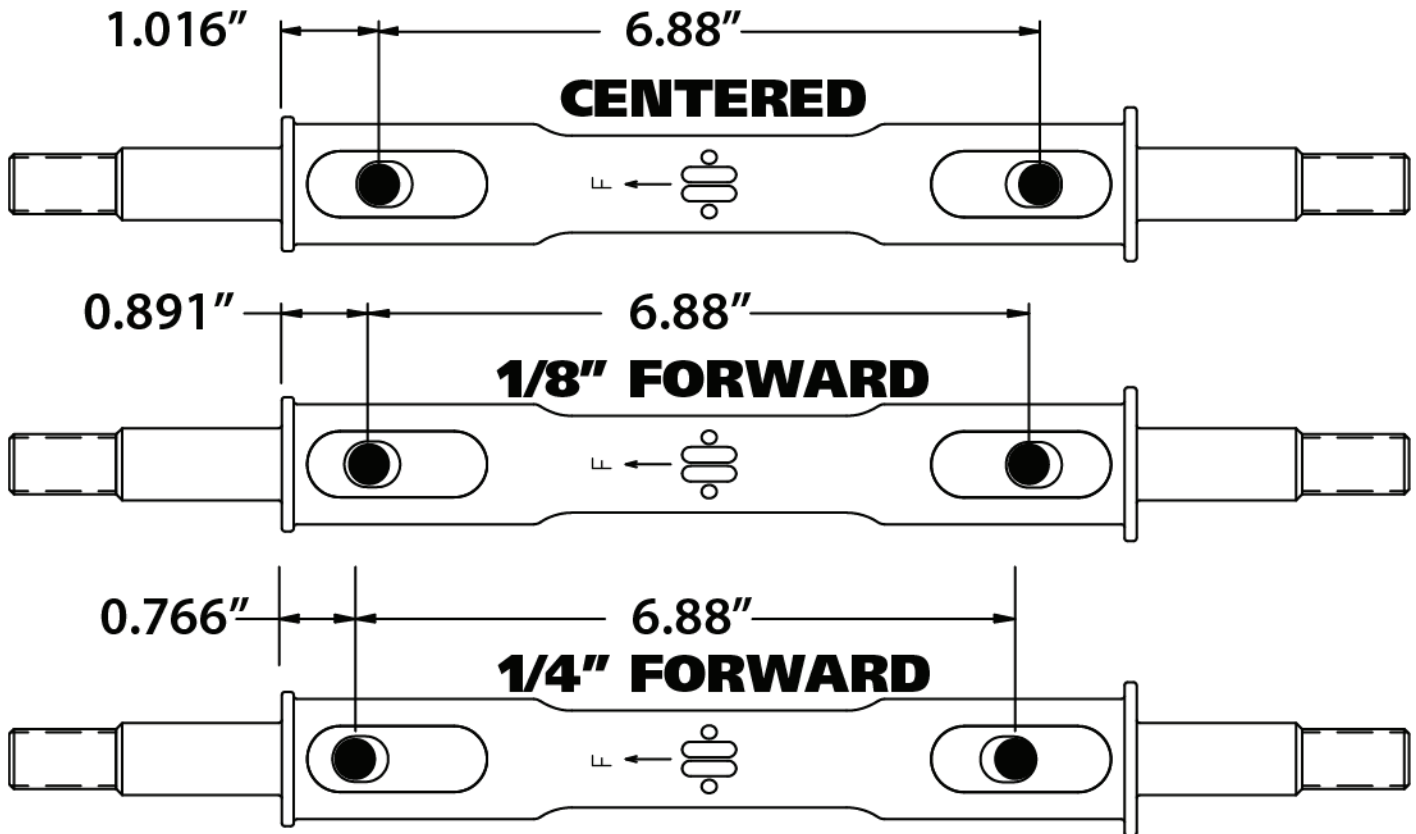

These Strong Arms come equipped with a changeable caster slug setup. This allows you to add or remove caster from the front suspension, if desired. The caster slugs that come in the kit are setup to put the control arm in the centered position, which is approximately 5 degrees of caster. The caster slugs allow you to add or remove caster without having to use a stack of shims. If more or less caster is desired, optional caster slugs can be purchased from your Ridetech dealer or Ridetech.

Caster Explained:

To understand caster you need to picture an imaginary line that runs through the upper ball joint and extends through the lower ball joint. From the side view the imaginary line will tilt forward or backward. The tilting of this imaginary line is defined as caster.

Caster is measured in degrees by using a caster camber gauge. If the imaginary line described above tilts towards the back of the car, at the top, then you will have positive caster. If the imaginary line tilts forward then you would have negative caster.

Positive caster provides the directional stability in your car. Too much positive caster will make the steering effort difficult. Power steering will allow you to run more positive caster. Negative caster requires less steering effort but can cause the car to wander down the highway.



Upper StrongArm Installation

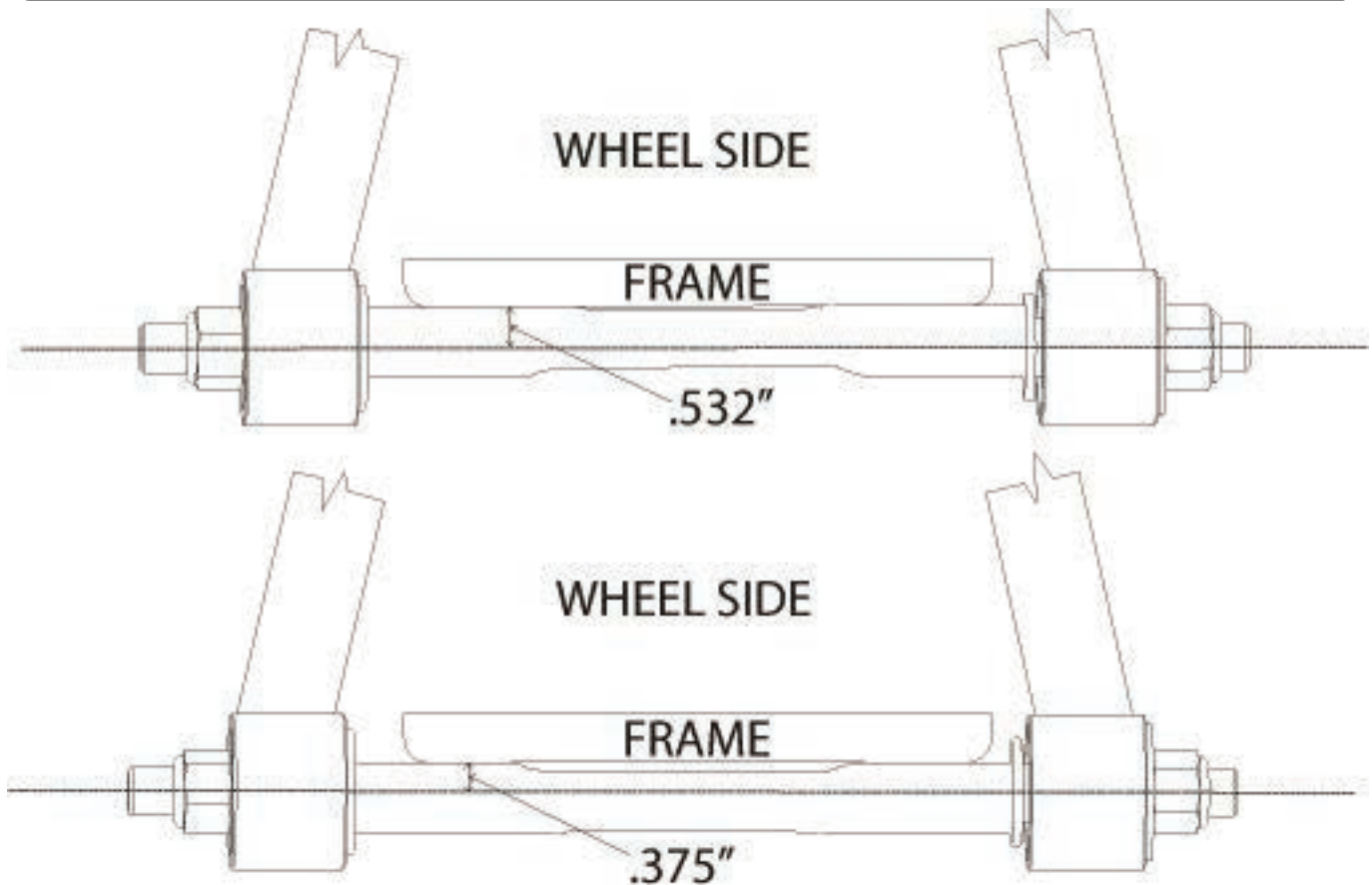

Offset Upper Cross Shaft

The cross shaft that is used in the upper control arm is offset. The offset combined with the caster slug option allows you to achieve the alignment setting you desire with minimal shims. To change the direction that the Icon faces, simply spin the cross shaft in the control arm.

If you are after an aggressive **Track or Autocross Alignment**, bolt the control arm to the frame bracket with the arm offset to the inside of the car (like the top illustration). The Ridetech Icon will be facing the engine.

If a **Street Alignment** is desired, bolt the control to the frame bracket with the arm offset to the outside of the car (like the bottom illustration). The Ridetech Icon will be facing the wheel.



Lower StrongArm Installation

82-03 S10 Lower StrongArms For Use w/ Shockwaves or CoilOvers

Components:

1	90002377	Driver side lower arm
1	90002378	Passenger side lower arm
2	90000896	Ball joint
2	90000572	Inner bushing sleeve
2	90001094	Inner bushing sleeve
8	70010759	Delrin bushing half
4	90002062	Aluminum spacer – Shock to lower arm

Hardware:

2	99501024	1/2"-13 x 3 1/4" Gr.5 bolt	Shockwave to lower arm
2	99502001	1/2"-13 Nylok nut	Shockwave to lower arm
2	99503001	1/2" Flat Washer	Shockwave to lower arm
2	99121001	M12-1.75 x 90mm Bolt	StrongArm to Frame
2	99122001	M12-1.75 Nylok Nut	StrongArm to Frame
2	99123002	M12-1.75 Flat Washer	StrongArm to Frame
2	99141003	M14-2.0 x 100mm Hex Bolt	StrongArm to Frame
2	99142002	M14-2.0 Nylok Nut	StrongArm to Frame
2	99143001	M14 Flat Washer	StrongArm to Frame



Lower StrongArm Installation



1. After removing the factory lower control arm, clean the bushing mounting surfaces on the frame to make sure they are fairly smooth.
2. Fasten the lower arm to the frame with the hardware supplied with the kit. The front bolt is M12 x 90mm, the rear is M14 x 110mm. Use a Flat Washer & Nylok on each.

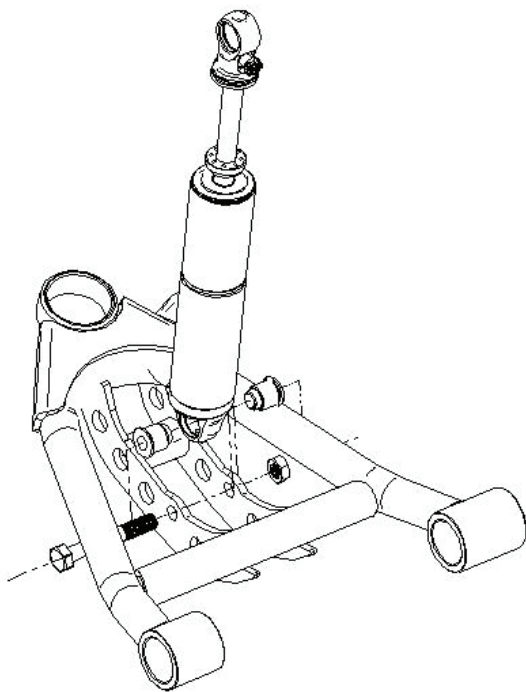

3. Swing the lower StrongArm up to the shock and secure with the $\frac{1}{2}$ " x $3\frac{1}{4}$ " bolt, flat washer, and Nylok nut, an aluminum spacer must be installed on each side of the bearing.
4. Slide the ball joint boot over the stud, then push the stud up through the spindle. Secure w/ the new castle nut and cotter pin supplied.
5. Grease the ball joints.



Lower StrongArm Installation

Item #	Description	Qty.
1.	Driver side arm	1
2.	Ball Joint	1
3.	Inner bushing sleeve – narrow	1
4.	Inner bushing sleeve – wide	1
5.	Delrin bushing half	2
6.	Delrin bushing half	2
7.	Aluminum bearing spacer	2
8.	1/2"-13 x 3 1/4" bolt	1
9.	1/2"-13 Nylok nut	1

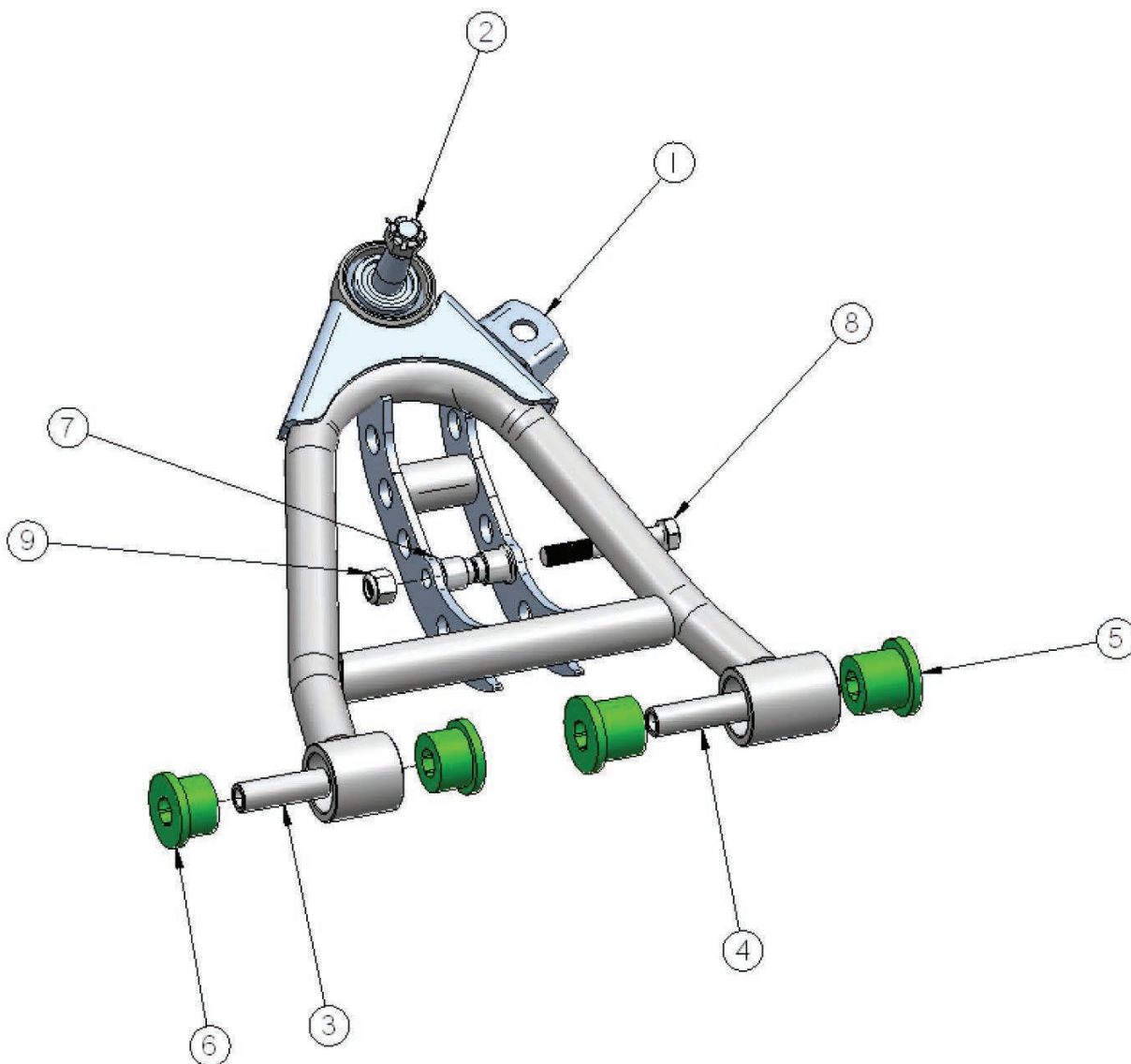



TruTurn Installation

82-03 S10 TruTurn System without Spindles



Item #	Part #	Description-Specification	Qty.
1.	90001590	Heim end	2
2.	99800002	5/8"-18 RH jam nut	2
3.	90002373	Heim End Spacer	4
4.	99622003	5/8"-18 Lock Nut-35 ft lbs	2
5.	90002374	Tie Rod Stud	2
6.	99432005	7/16"-20 castle nut-35 ft lbs	2
7.	90002375	Adjusting sleeve	2
8.	99952002	3/32" cotter pin	2
9.	99800003	5/8"-18 LH jam nut	2
	90003058	Inner Tie Rod (not shown)	2

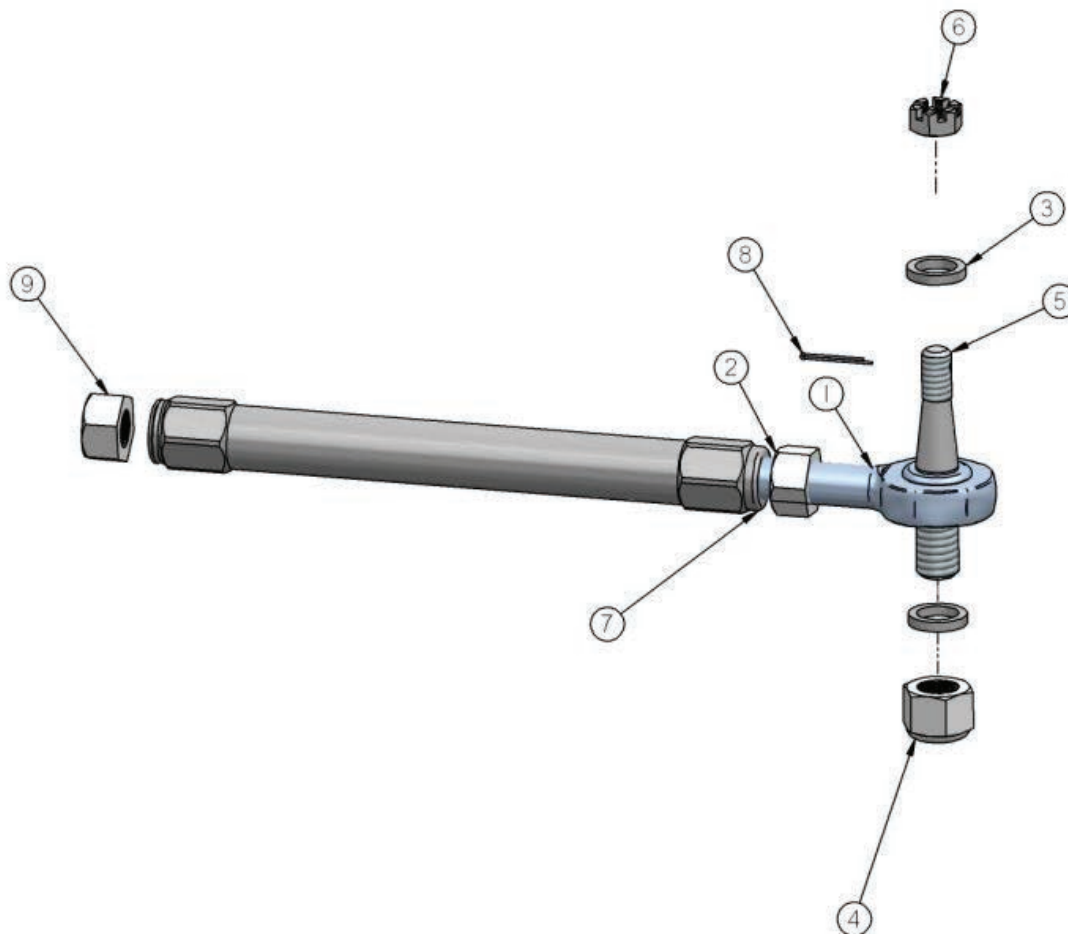



TruTurn Installation

Installation instructions:

NOTE: The number in (#) is the number of the part in the drawing on the previous page.

1. Raise and safely support the front of your vehicle at a comfortable working level
2. Remove existing outer tie rod and adjuster leaving the inner tie rod.
3. Install the (5) Tie Rod Stud into your factory spindle using the (6)7/16" castle nut. Torque the nut to 35 ft lbs and install (8) cotter pin. **NOTE:** If none of the holes line up tighten the nut until you can get the hole to line up with a slot.
4. Install the (7) Right Hand thread nut onto the (1) heim end and (9) Left hand nut onto the factory tie rod.
5. Antiseize the threads on the factory tie rod and heim end to prevent the threads from galling.
6. The left hand threaded side of the (7) adjuster goes onto the factory tie rod; it has a groove cut into the end of the adjuster. You will want the thread engagement the same on the tie rod end and the heim, the easy way to do this is set then nut on the tie rod 1 1/4" from the end of the tie rod and thread the adjuster on so that it touches the nut.
7. Install the heim end into the other end of the adjuster. Start by threading the lock nut all the way on the heim end and thread the heim end into the adjuster so that it touches the nut.
8. Install the heim end side of the tie rod onto the tie rod stud using the (3) aluminum spacer on top and bottom of the heim end and then install the (4)5/8" lock nut. Torque nut to 35 ft lbs.
9. Set the center to center length of the tie rod assembly to 17 3/4" by turning the adjuster out. This will get you close on the toe setting but it will need to be aligned. **USE THE SIGHT HOLES IN THE SIDE OF THE TIE ROD ADJUSTER TO ENSURE PROPER THREAD ENGAGEMENT.**
10. Adjust the camber and toe roughly until you can get the vehicle to a proper alignment shop. The recommended alignment settings are:

Camber - -.5 to -1.5 [within .3 from side to side]

Caster - 4 to 7 degrees positive

Toe - 1/16" to 1/8" toe in

Feel free to experiment with alternative alignment settings that may be more appropriate for your particular driving style.

Installation notes:

- A. **MAKE SURE** that the cotter pins are properly installed in all appropriate places [C] to ensure that the castle nuts do not become loose and fail. These are VERY important connections!



Part # 11399120 - 1982-2003 S10/S15 Front SwayBar



Recommended Tools



1982-2003 S10/S15 Front SwayBar Installation Instructions

Table of contents	
Page 19.....	Included Components and Hardware List
Page 20.....	SwayBar Installation

Hardware Torque Specifications

5/16"-16.....	17 ftlbs
3/8"-16.....	30 ftlbs

Major ComponentsIn the box

Part #	Description	QTY
90001243	Front SwayBar	1
90002937	End Link Kit	1
70012394	Delrin Sway Bar Bushing Liner	2
90002513	Bushing Strap	2
90001099	SwayBar Bushing	2
90001268	Bushing Mount Adapter - Driver	1
90001267	Bushing Mount Adapter - Passenger	1

HARDWARE KIT.....99010088

QTY	Part #	Description	QTY	Part #	Description
ADAPTER PLATE			BUSHING STRAP		
4	99111001	M10-1.5 x 30MM Flat Head	4	99371065	3/8" -16 x 3/4" Hex Bolt
1	90002263	Red Loctite	4	99373002	3/8" Flat Washer
			4	99373006	3/8" Split Lock Washer

Getting Started.....

This SwayBar Kit utilizes a Delrin Liner in the SwayBar Bushing. The Delrin Liner allows the SwayBar to move freely and quietly in the Bushing. The Delrin is self-lubricating, no lubrication is required.

1. Jack the vehicle up to a safe working height and support with jack stands. Make sure the jack stands are stable before working under the car.
2. Remove the stock sway bar.
3. After removing the stock sway bar, determine what size hardware the frame will require.



4. Open the Delrin Liner at the split and slip it over the SwayBar. Position it in the area that the bushing will ride based on the location of the stock swaybar. Do this on both ends of the swaybar.



5. Open the SwayBar Bushing at the split and slide it **OVER** the Delrin Liner. Do this on both Delrin Liners. Next, slip the Bushing Straps over the SwayBar Bushings.



6. Hold the Frame Plate up to the OEM holes, the Counter Sunk holes will line up with the OEM threaded holes. The Plates are positioned with the threaded holes offset to the **FRONT and INSIDE of the truck**. Apply Red Loctite to the Flat Head Bolts. Torque Hardware.



7. Slide the SwayBar into position on the S10 with the SwayBar arms above the tie rods. Install a 3/8" Lock Washer & 3/8" Flat Washer on the 3/8"x 3/4" Hex Bolts. Do **NOT** Complete tighten the Hardware, it will be left partially loose until the End Links are installed.



8. Install the End Links using **Diagram 1** as a reference. Install both end links before tightening the end link hardware. Tighten the end link barrel nut until it is flush with the end of the bolt, and then tighten it 2-3 more complete rounds.

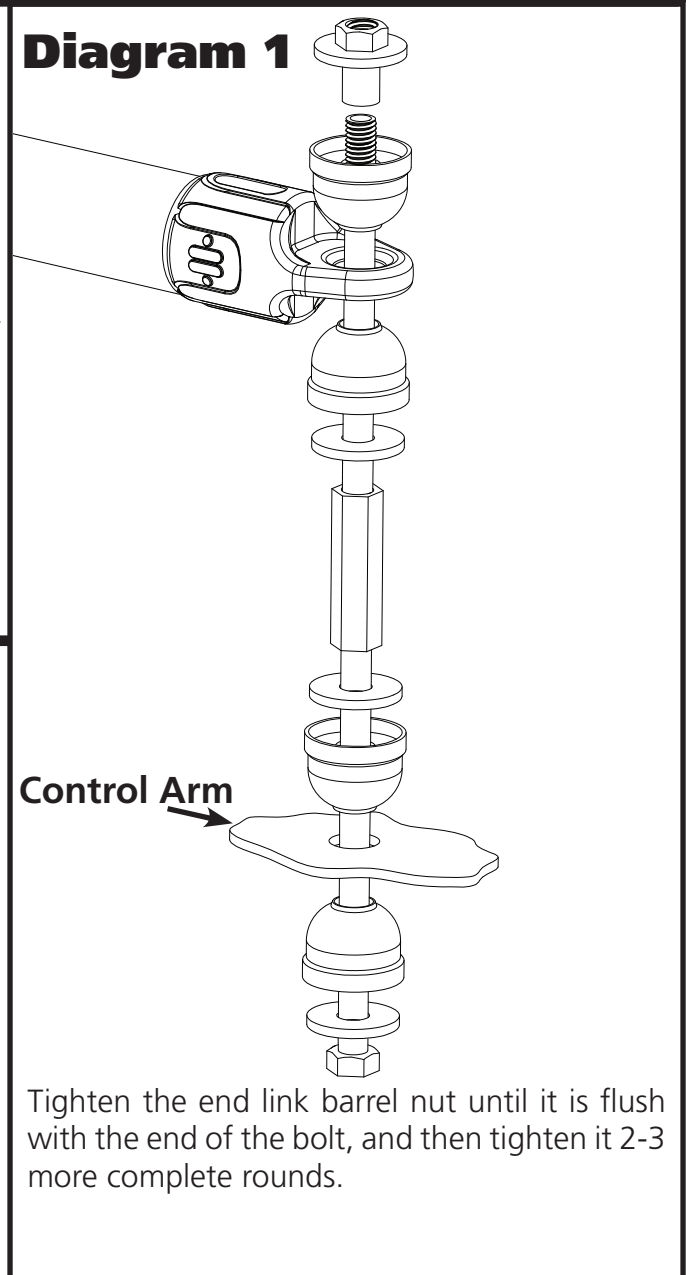

9. Torque the SwayBar mounting hardware to 30 ftlbs. Install the locking rings on the inside of each bushing assembly. Use a hex key to take the locking ring apart. Reassemble it on the bar positioned next to the inside of the bushing assembly. Push the locking ring up against the bushing assembly and tighten.



Part # 11397199

1982-2002 S10/S15 Rear Bolt-On Wishbone Suspension System

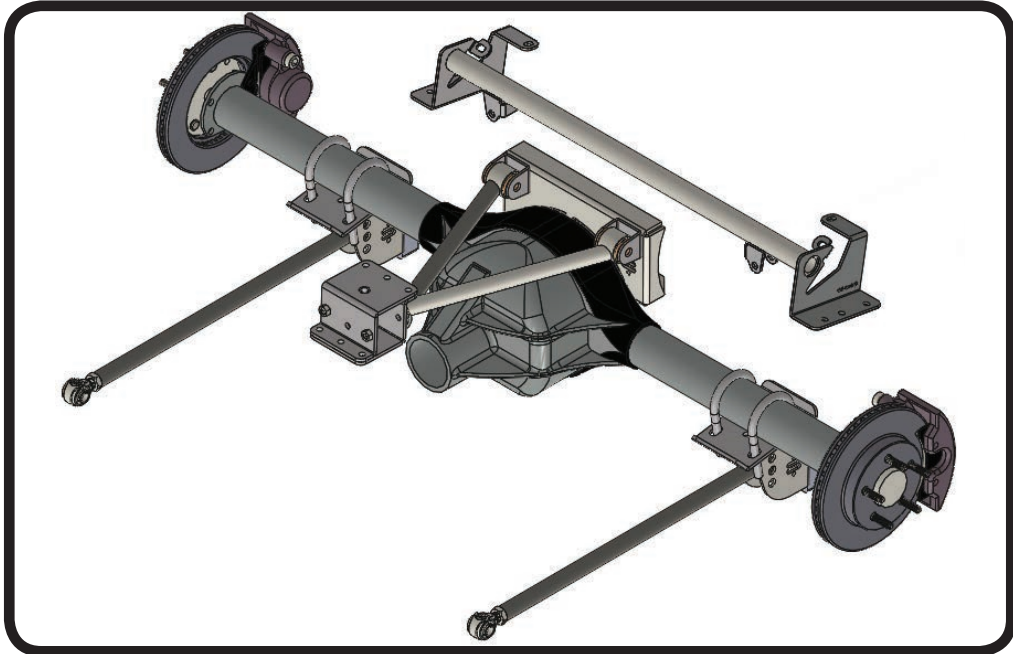

Recommended Tools



1982-2002 S10/S15 Rear Suspension Installation Instructions

Table of contents

Page 22-23.....	Included Components
Page 24.....	Hardware List & Disassembly
Page 25.....	Getting Started
Page 26-27.....	Crossmember Wishbone Mount Installation
Page 28.....	Upper Crossmember Installation
Page 29-31.....	Wishbone Installation
Page 32.....	Lower Mount & Lower Bar Installation
Page 33.....	Lower Bar & ShockWave/CoilOver Installation
Page 33-34.....	Shockwave/CoilOvers Installation

NOTE: Due to the various locations of the emissions equipment, etc. over the years, you may need to relocate items such as the charcoal canister, fuel lines, brake lines, and electrical wiring. A little thought and care goes a long way here! Typically the fuel lines, brake lines and wiring can be simply moved aside if they are in the way, while the charcoal canister may need to be repositioned entirely.





Major ComponentsIn the box

Item #	Part #	Description	QTY
1	90002901	Lower Axle Bracket	2
2	90002902	Rear Upper ShockWave/CoilOver Mount Crossmember	1
3	90000387	Upper Wishbone Crossmember Bracket - Front Half	1
4	90002904	Upper Wishbone Crossmember Bracket with Mount - Rear Half	1
5	90002870	Rear Upper Wishbone	1
6	90002903	Rear Upper Control Arm Differential Mount	1
7	90002869	Lower Bars - Set to 26 1/4"	2
8	70013364	RH R-Joint Threaded Housing	2
9	90001617	5/8" Shock Stud	2
10	90001624	Aluminum Lower Shock Mount	2
11	90002067	Lower Shock Bearing Spacers	4
12	70013540	Narrow R-Joint Spacers (680" Long) - upper control arm and rear lower bar	6
13	70013768	Wide R-Joint Spacer (1.240" Long) - Lower Bars - front lower	4
14	70010759	Delrin Bushings - installed in upper control arm	4
15	90002895	Delrin Bushing Inner Sleeves - installed in upper control arm	2
16	99752004	3/4"-16 Jam Nut - Installed on Upper Control Arm	2
17	99566004	U-Bolt- 9/16-18 x 3.13 x 5 w/2" Thread	4
R-Joint Components - (Installed in bar ends and front of wishbone)			
	70013279	Retaining Ring	5
	70013280	Wavo Wave Spring	5
	70013275	R-Joint Center Ball	5
	70013276	R-Joint Composite Center Ball Cage	5

New R-Joints will be quite stiff (75-90 in/lbs breakaway torque) until they "break in" after a few miles of use. After the break in period they will move much more freely. Because the composite bearing race contains self lubricating ingredients, no additional lubrication is needed or desired. Any additional lubrication will only serve to attract more dirt and debris to the R-Joint and actually shorten its life.



Major ComponentsIn the box

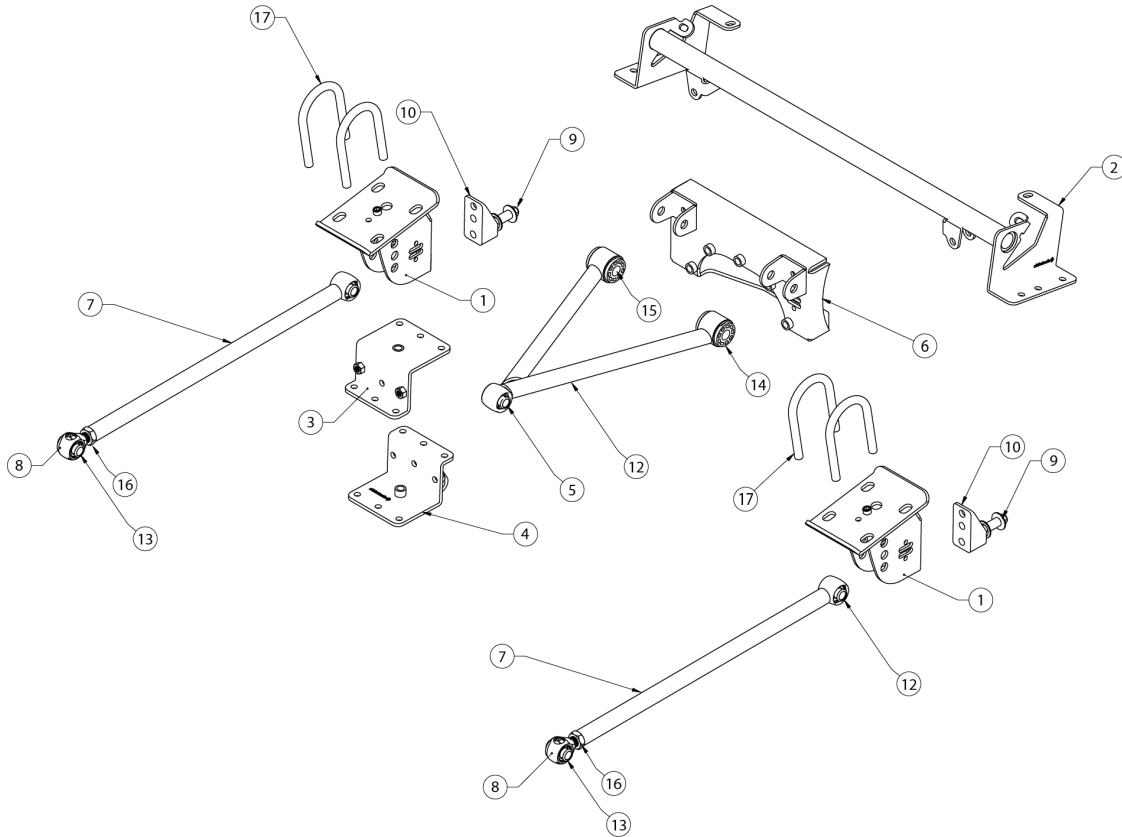

R-JOINT SPACER INSTALLATION

Install the Spacers by inserting the SMALL side of the SPACER into the Center Pivot Ball. Push them in until they bottom out and stop.

LOWER FRONT R-JOINT

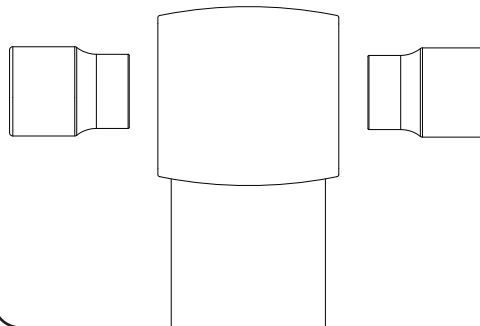

ALL OTHER R-JOINTS

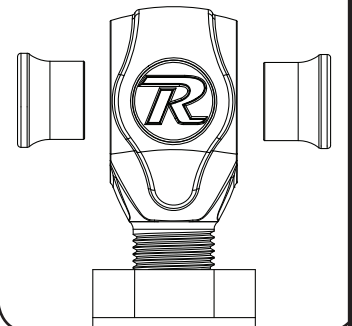

New R-Joints will be quite stiff (75-90 in/lbs breakaway torque) until they "break in" after a few miles of use. After the break in period they will move much more freely. Because the composite bearing race contains self lubricating ingredients, no additional lubrication is needed or desired. Any additional lubrication will only serve to attract more dirt and debris to the R-Joint and actually shorten its life.



Hardware ListIn the box (Kit# 99010082)

The Hardware Kit contains bags to help aid in selecting the correct hardware for the component being installed. The hardware list shows how the hardware is bagged.

QTY	Part Number	Description	QTY	Part Number	Description
WISHBONE FRONT CROSSMEMBER MOUNT			UPPER WISHBONE DIFFERENTIAL MOUNT		
6	99371004	3/8"-16 x 1 1/4"	5	99315002	5/16-18 x 2 1/2" Gr. 8 Stud
12	99373003	3/8" Flat Washer	5	99313001	5/16" Flat Washer Gr. 8
6	99372002	3/8"-16 Nylok Nut	5	99312002	5/16"-18 Nylok Nut Gr. 8
4	99431001	7/16"-14 x 1"	2	99312007	5/16"-18 Hex Nut
UPPER CONTROL ARM MOUNTING			1	90002263	Red Loctite
1	99621004	5/8"x 3" SAE Gr. 8 Bolt	AXLE BRACKET TO AXLE		
3	99622006	5/8" SAE Nylok Jam Nut	8	99562010	9/16" SAE High Nut
6	99623001	5/8" SAE Flat Washer	8	99566003	9/16" SAE Flat Washer
2	99621005	5/8 x 3 1/2" Hex Bolt	UPPER CROSSMEMBER		
LOWER 4LINK BARS			10	99371004	3/8"-16 x 1 1/4" Hex Bolt
2	99561012	9/16" x 4 1/2" SAE GR8 Bolt	20	99373003	3/8" Flat Washer
4	99566003	9/16" SAE Flat Washer	10	99372002	3/8"-16 Nylok Nut
2	99562003	9/16" SAE Nylok Nut	UPPER SHOCK MOUNTING		
2	99621004	5/8"x 3" SAE Gr. 8 Bolt	2	99501050	1/2" x 2 1/2" USS Bolt Gr. 8
2	99622006	5/8" SAE Nylok Jam Nut	2	99502009	1/2" USS Nylok Nut Gr. 8
4	99623001	5/8" SAE Flat Washer	4	99503012	1/2" SAE Flat Washer Gr. 8
BRAKE LINE JUNCTION BLOCK			LOWER SHOCK MOUNT		
1	99311003	5/16"-18 x 1 1/2" Hex Bolt	2	99501019	1/2"-13 x 1 1/4" Hex Bolt
2	99313002	5/16" Flat Washer	2	99501046	1/2"-13 x 1 3/4" Hex Bolt
1	99312003	5/16"-18 Nylok Nut	4	99502001	1/2"-13 Nylok Nut
1	99000008	7/8" Insulated Clamp	4	99503001	1/2" SAE Flat Washer

Disassembly

Congratulations on your purchase of the Ridetech Rear Wishbone System. This system has been designed to give your truck excellent handling along with a lifetime of enjoyment. Some of the key features of this system: 3Link setup to replace the leaf spring and provide better control of the rear axle, upper wishbone to eliminate the side-to-side movement of the differential, R-joints for excellent wear and quiet operation, and the biggest feature of all, it allows the use of ShockWaves or CoilOvers.

Note: This system is designed for use with the Ridetech ShockWaves or CoilOvers. **The factory shocks and springs or the factory sway bar will not fit this 4Link.**



Getting Started.....

1. Raise the truck to a safe and comfortable working height and support it by the frame. You will need to be able to raise and lower the differential. Use a jack under the rear differential so it can be raised and lowered as needed during the install.
2. Remove the bed, retaining the hardware for reassembly. This kit can NOT be installed with the bed on.
3. Remove the leaf springs and shock absorbers. Refer to the factory service manual for proper disassembly procedures. If the Truck has the ZQ8 suspension package, the horizontal shock absorber will need to be removed.



4. Remove the OEM bumpstop and bracket. A die grinder with a cutoff wheel works well for this. We use the cutoff wheel to cut the weld, taking care to not cut into the frame.



5. Grind the frame smooth after removing the bumpstop bracket. We recommend painting the area to prevent future rust.



Crossmember Wishbone Mount Installation



6. If your truck came equipped with the emissions module mounted at the center of the gas tank crossmember, it will need to be relocated. The emissions control locations vary through the years.

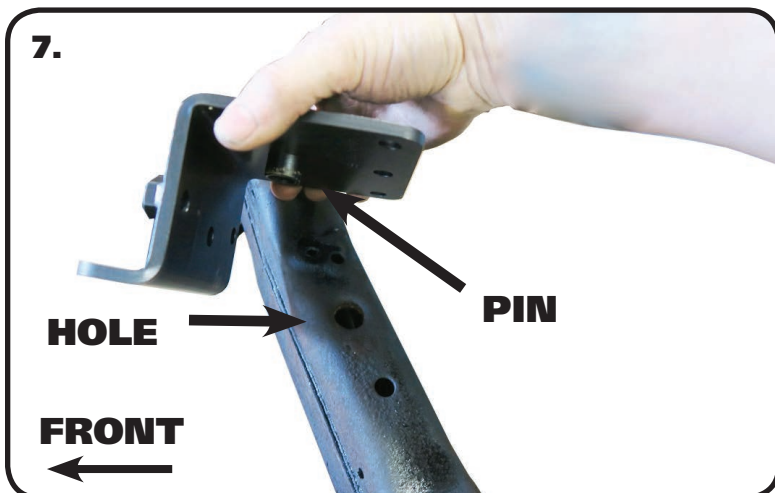

7. The Wishbone Crossmember Mount uses the Hardware Bag labeled "Wishbone Front Crossmember Mount". Use **Images 7 - 10** as a reference for installing the front Wishbone Mount. It sits on top of the gas tank crossmember with the **PIN** engaged into the **CENTER HOLE** of the crossmember. The Wishbone Mounting Point is to the **REAR** of the truck. In **Image 7**, the installer is lining up the pin with the locating hole in the crossmember.

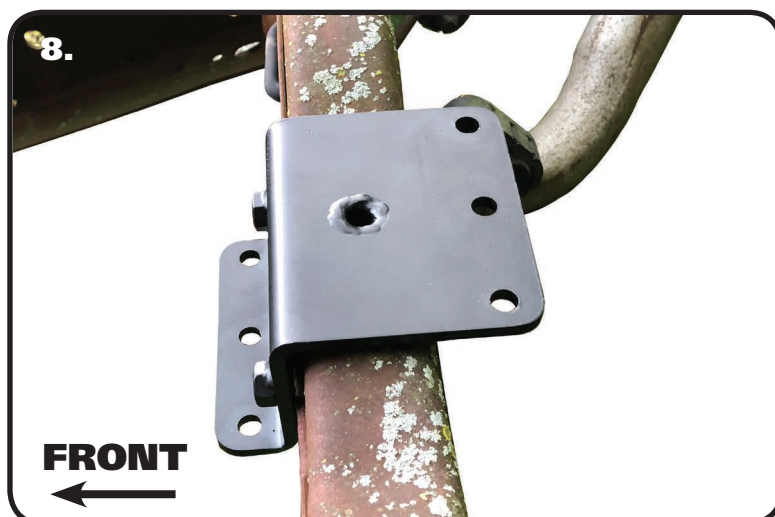

8. The Front portion of the Wishbone Mount sits on top of the gas tank crossmember.



Wishbone Mount & Upper Crossmember Installation



9. The Rear half of the Wishbone Mount is installed against the bottom of the gas tank crossmember with the PIN ENGAGED IN THE HOLE. The Rear Half has the Wishbone Mounr built into it. The 2 halves are bolted together using (6) 3/8"-16 x 1 1/4" Hex bolts, (6) 3/8"-16 Nylok Nuts, & (12) 3/8" SAE Flat Washers. Install a Flat Washer on each on the (6) Bolts. Hold the front half of the Wishbone Mount in place and insert a bolt/washer in each of the (6) holes. Install a 3/8" SAE Flat Washer and Nylok Nut on each of the Bolts. Torque to 30 ftlbs.

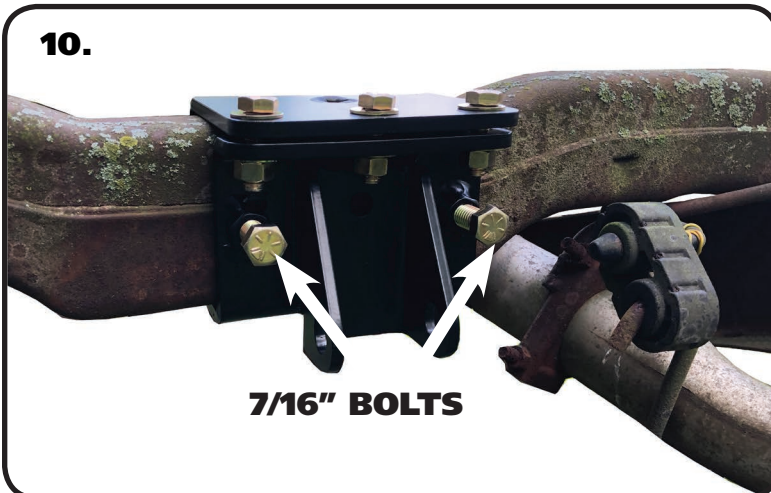

10. The Wishbone Mount has (2) 7/16"-14 Threaded Holes, front and rear. These are used if the Wishbone Mount fits the crossmember loosely. If it is loose, install a 7/16"-15 x 1" Bolt into each hole. Tighten the Bolts until the Mount is fitting tightly on the crossmember.

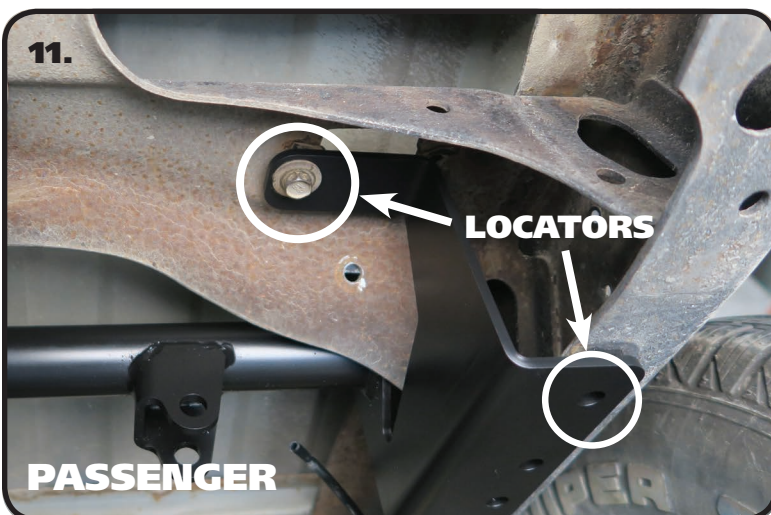

11. Upper Crossmember Installation. The Upper Crossmember uses the Hardware Bag labeled "Upper Crossmember". The Upper Crossmember locates off the OEM upper shock holes & the REAR Hole of the Bottom Flange. Remove the OEM u-nuts from the shock mounting holes, if equipped. Holding the Crossmember in position, bolt the locating tabs to the shock mounting holes using (1) 3/8"-16 x 1 1/4" Bolt, (2) 3/8" Flat Washers, & (1) 3/8"-16 Nylok Nut in each locating tab. Do the same for the Bottom Flange. Install the Hardware in both sides. Snug the hardware down, but do not tighten at this time.



Upper Crossmember Installation



12. The NEW Crossmember has a Tab that rests against the top of the OEM shock crossmember. A hole will need to be drilled from the bottom side. The next 2 steps show you how to mark the hole location from the bottom. Measure over 4" from the inside of the frame rail and put a couple marks above and below the tape measure.

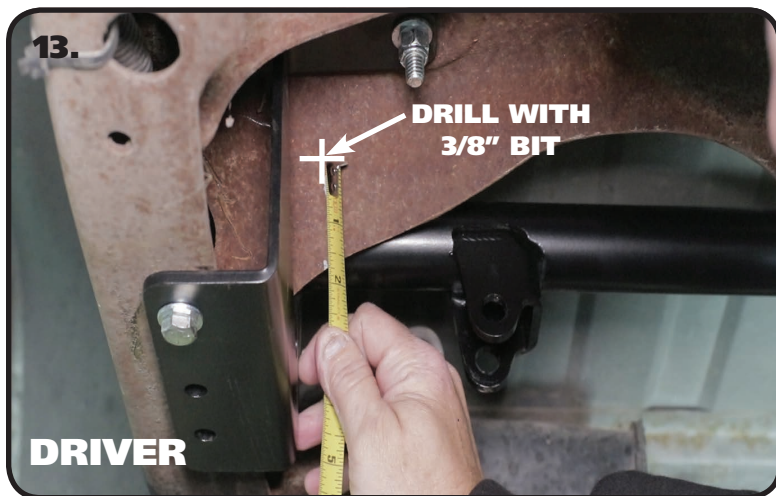

13. Measure up 1 3/4" from the bottom edge of the OEM crossmember keeping the tape measure in line with the marks. Put a mark at the 1 3/4" measurement. If there isn't a 4" mark, you will need one to mark center of the hole.



14. Drill the center of the marks with 3/8" Drill Bit. You will also need to drill the (2) holes in each Bottom Flange using the crossmember as a template. Use a drill with a 3/8" Drill Bit. Drill the (3) holes in the driver and passenger sides. Install a 3/8" Flat Washer on each of the (8) remaining 3/8"-16 x 1 1/4" bolts. Insert each of them into one of the drilled holes. Install a 3/8" Flat Washer and 3/8"-16 Nylok Nut on each bolt. Torque to 30 ftlbs. Also, Torque the (4) that were installed previously.



Wishbone Installation

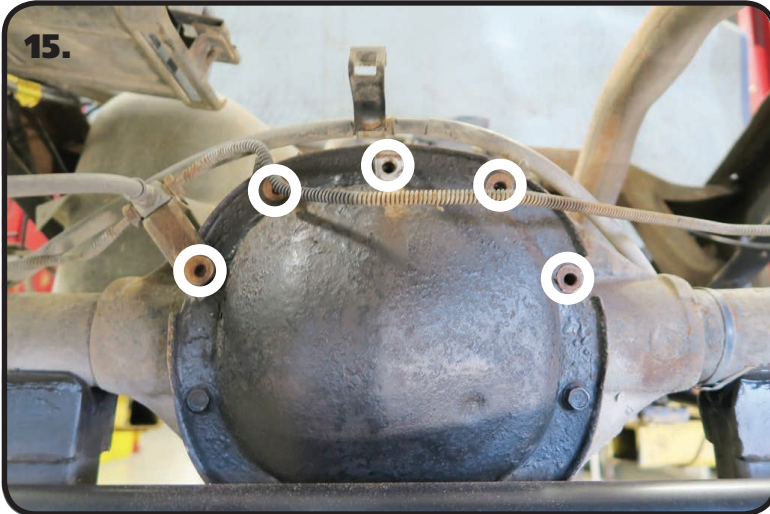

15. Remove the **TOP 5 Bolts** from the differential cover. These are Circled in **Image 15**. Also remove the mounting bracket from the brake line distribution "T" and the emergency brake cable mounting bracket.

IF THE DIFFERENTIAL COVER HAS A GASKET BETWEEN IT AND THE HOUSING, IT WILL NEED TO BE REMOVED AND SEALED WITH RTV SEALANT. Be sure to refill the differential with the correct gear oil before driving.

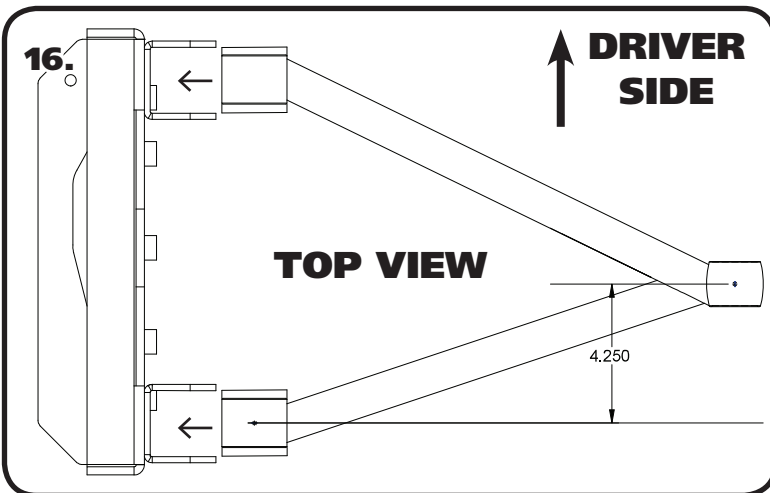

16. The Upper Wishbone front R-Joint is offset to the passenger side. Use **Images 15 & 16** as a reference for assembling the Upper Wishbone to the Wishbone Axle Mount. Slip the wishbone into the Mount with the Front R-Joint offset to the passenger side.

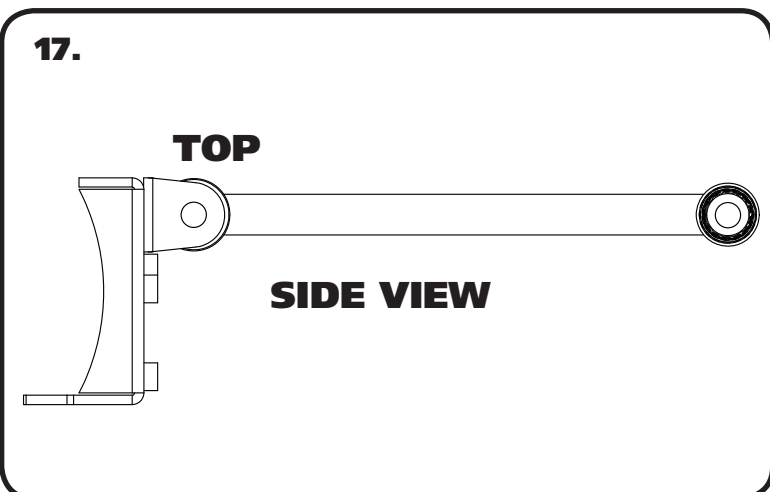

17. The Wishbone Mounts are to the **TOP** of the Axle Mount. Insert the Wishbone into the Mount lining up the holes in the mount with the Inner Bushing Sleeves.



Wishbone Installation

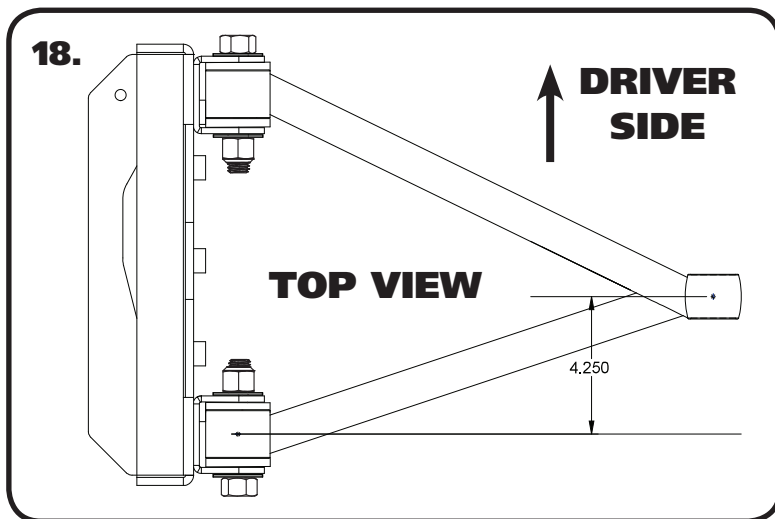

18. Using the Hardware Bag "Upper Wishbone Mounting", install a 5/8" Flat Washer on each of (2) 5/8"-18 x 3 1/2" Bolts. Install each Bolt/Washer from the outside. With the bolts installed, install a 5/8" Flat Washer & 5/8"-18 Nylok Nut on each bolt. Tighten the Bolts/Nuts enough to eliminate any gaps.

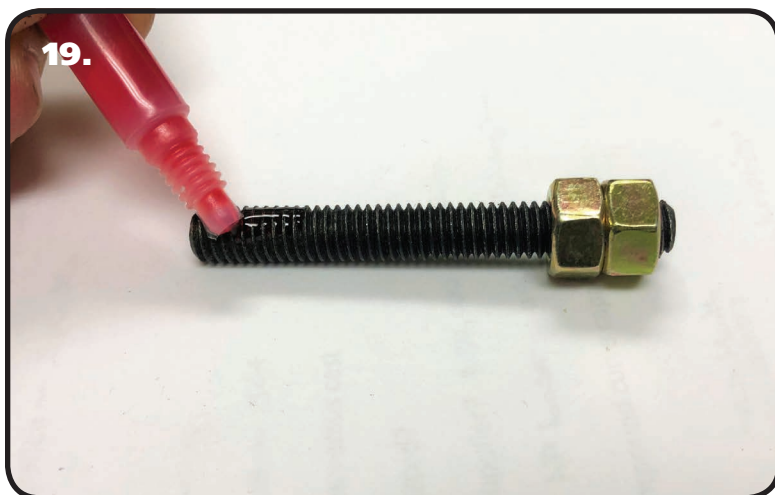

19. The 5 OEM bolts that were removed from the top of the differential cover will be replaced with 5/16"-18 x 2 1/2" Studs. These Studs and the nuts used to install them, are supplied in the Hardware Bag labeled "Upper Wishbone Differential Mount". Thread the (2) 5/16"-18 Hex Nuts on one of the studs. Using (2) wrenches, tighten the nuts against each other locking them together. Apply Red Loctite to the other end of the stud.



20. Thread the Stud into one of the 5 threaded holes in the axle housing. Torque the Stud to 25 ftlbs. Use 2 wrenches to unlock the nuts from each other and remove them from the stud. Repeat the process on the remaining 4 studs.



Wishbone Installation



21. Line the 5 holes in the Axle bracket with the 5 Studs that were just installed in the axle housing. Using the Hardware Bag "Upper Wishbone Differential Mount", install a 5/16" Flat Washer, followed by a 5/16"-18 Nylok Nut on each of the (5) Studs. Torque the nuts to 25 ftlbs.

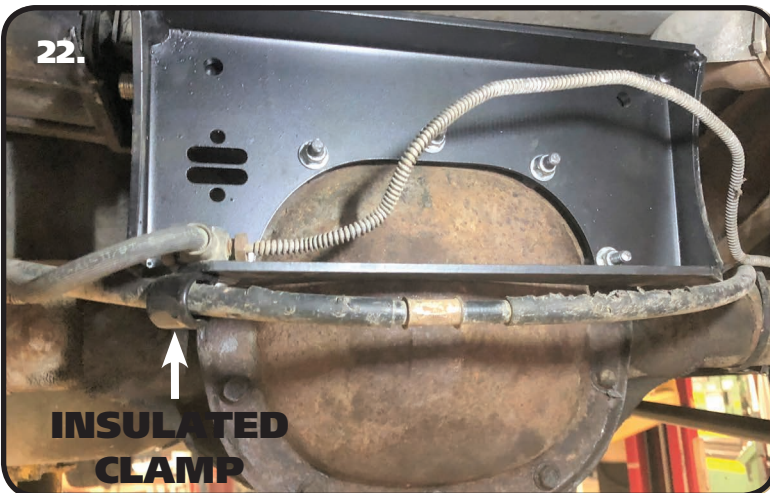

22. Using the Hardware Bag "Brake Line Junction Block", install a 5/16" Flat Washer on a 5/16"-18 x 1/2" Bolts. Insert the bolt/washer through the junction block and mounting hole in the differential bracket. Install the Insulated Clamp on the emergency brake cable, it will attach to the 5/16" bolt on the bottom side of the axle mount. Slip the mounting hole of the clamp onto the threads of the 5/16" bolt. Install a 5/16" Flat Washer & 5/16"-18 Nylok Nut on the threads of the bolt. The brake lines will need to be tweaked to get the distribution block in position. Torque the bolts to 25 ftlbs.

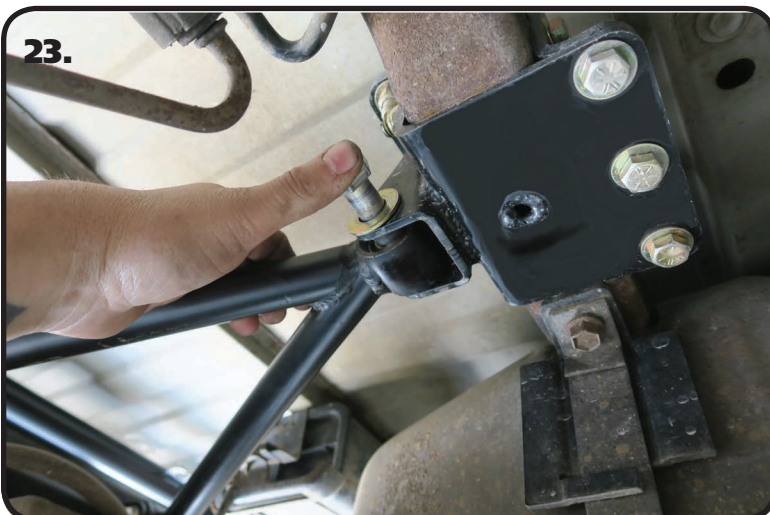

23. Insert a Narrow R-Joint Spacer (.680") into each side of the front R-joint of the Wishbone. Using the Hardware Bag "Upper Wishbone Mounting", install a 5/8" Flat Washer on a 5/8"-18 x 3" Bolt. Line up the R-Joint with the Front Wishbone Mount. Insert the bolt/washer in the lined up r-joint/mount. With the bolt installed, install a 5/8" Flat Washer & 5/8"-18 Nylok Nut on the bolt. Tighten the Bolts/Nuts enough to eliminate any gaps.



Lower Mount & Lower Bar Installation



24. The Axle Mounts are the same for driver and passenger sides. Install the supplied 9/16" U-bolts on each side of the OEM leaf spring pads. Slide an Axle Mount on the U-bolts with the center pin inserted into the leaf spring pad. The hardware bag is labeled "Lower Axle Bracket to Axle". Hold the mount in place and install a 9/16" Flat Washer and 9/16" High Nut on the threads of the u-bolts sticking through the axle mount. Tighten the nuts evenly in a crisscross fashion making sure the center pin is engaged into the leaf spring pad. Torque the nuts in a crisscross fashion to 60 ftlbs. Repeat on the other side.



25. The Hardware Bag for the Lower Shock Mount is labeled "Lower Shock Mounting". The Lower Shock Mount attaches with (1) 1/2"-13 x 1 1/4" Hex Bolt, (1) 1/3"-13 x 1 3/4" Hex Bolt, & (2) 1/2" Flat Washers, & (2) 1/2"-13 Nylok Nuts. The Lower Mount gets attached to the TOP 2 holes of the Axle Mount. Insert the Bolts through the Aluminum Shock Mount with the 1 1/4" long bolt in the top hole, 1 3/4" in the bottom hole. Insert the bolts through the TOP 2 holes of the Axle Mount and install the Flat Washers & Nylok Nuts on the Threads sticking through. Repeat on both sides and torque the Bolts/Nuts to 75 ftlbs. Install a 5/8" Flat Washer onto the 5/8"-18 threads of the shock stud. Apply Red Loctite to the 5/8" threads of the stud. Thread the Shock Stud into the threaded hole of the Lower Mount. Repeat on both sides and torque the Shock Stud to 65-75 ftlbs.



26. The hardware bag for the lower bars is labeled "Lower Link Bars". Insert the long R-Joint Spacers (1.240" long) into the front of the lower bar with the small OD inserted into the R-joint. Insert the Front Lower Bar R-Joint into the Front Leaf Spring Mount. Line the through hole of the R-Joint with the holes of the leaf spring mount. Install a 9/16" Flat Washer on to a 9/16"-18 x 4 1/2" Hex Bolt, insert into the lined up holes. Install a 9/16" Flat Washer followed by a 9/16"-18 Thin Jam Nylok Nut. Repeat on both sides and tighten the Bolts/Nuts enough to eliminate any gaps.



Lower Bar & ShockWave/CoilOver Installation

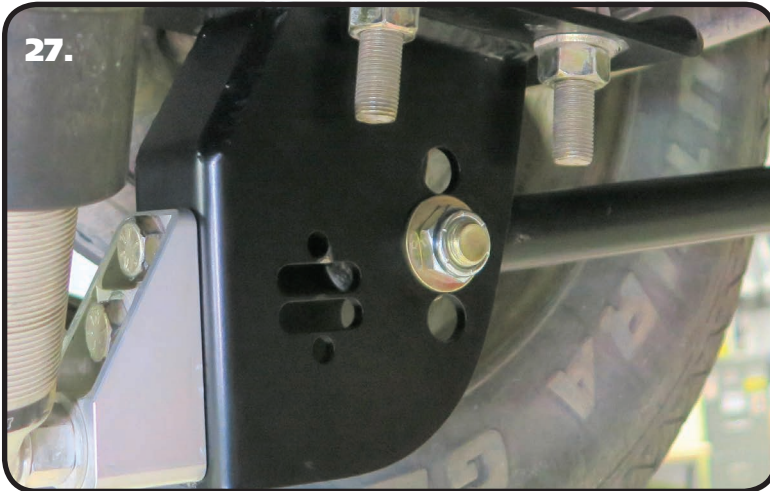

27. The rear of the Lower Bar gets bolted into the center set of holes. Insert 2 narrow R-Joint Spacers (.680" long) into the R-Joint of one end of each Lower Bars. Insert the Rear Lower Bar R-Joint into the Lower Axle Bracket. Line the through hole of the R-Joint with the holes of the Axle Bracket. Install a 5/8" Flat Washer on to a 5/8"-18 x 3" Hex Bolt, insert into the lined up holes. Install a 5/8" Flat Washer followed by a 5/8"-18 Thin Jam Nylok Nut. Repeat on both sides and tighten the Bolts/Nuts enough to eliminate any gaps.



28. Insert the 1/2" ID Shock Bearing Spacer into each side of the ShockWave/CoilOver Bearing. Install a 1/2" Flat Washer on a 1/2"-13 x 2 3/4" Bolt. If installing ShockWaves, insert the top of the shock into the shock mount on the upper crossmember with the adjusting knob to the inside. If installing CoilOver, insert the bottom of the shock into the shock mount on the upper crossmember. Line up the holes and insert the bolt/washer. Install a 1/2" Flat Washer and 1/2"-13 Nylok Nut on the threads and tighten to 50 ftlbs.



29. The Shock Stud requires Bearing Spacers that are .400" long (90002067). Install a 5/8" ID 90002067 spacer (**Small side towards shock body**) onto the lower Shock Stud. Slide the bottom of the Shock onto the Stud. Install a second 5/8" ID 90002067 Spacer onto the Stud (**small side towards shock**). You may need to jack the rear end up to Slide the Shock onto the Stud. Install the 7/16" Flat washer and 7/16" Nylok nut. Tighten the upper and lower shock bolts. Torque the Upper Bolt to 50 ftlbs and the Lower Nut to 40 ftlbs. The designed ride height of the CoilOver/Shockwave is 14 1/2" center to center.



ShockWave/CoilOver Installation



30. This particular truck had the emissions canister mounted right behind the gas tank. We had to trim the rear corner off for clearance of the new lowered suspension.



31. Image 31 illustrates where we moved the differential vent that was on top of the crossmember. It will bolt in the hole that the emissions module was bolted into using the OEM hardware.



32. For Trucks with the Emissions Control on the gas tank crossmember, we attached it to the end of the Charcoal Canister.

33. Setting Ride Height - The Shock mount to mount dimension should be 14 1/2". For trucks with ShockWaves, it's a matter of adjusting the air pressure to obtain the ride height. CoilOver trucks will require adjusting the coilspring spanner nut on the shock to obtain the correct ride height.



Part # 21150701 - 5.2" Stroke HQ Series Shockwave

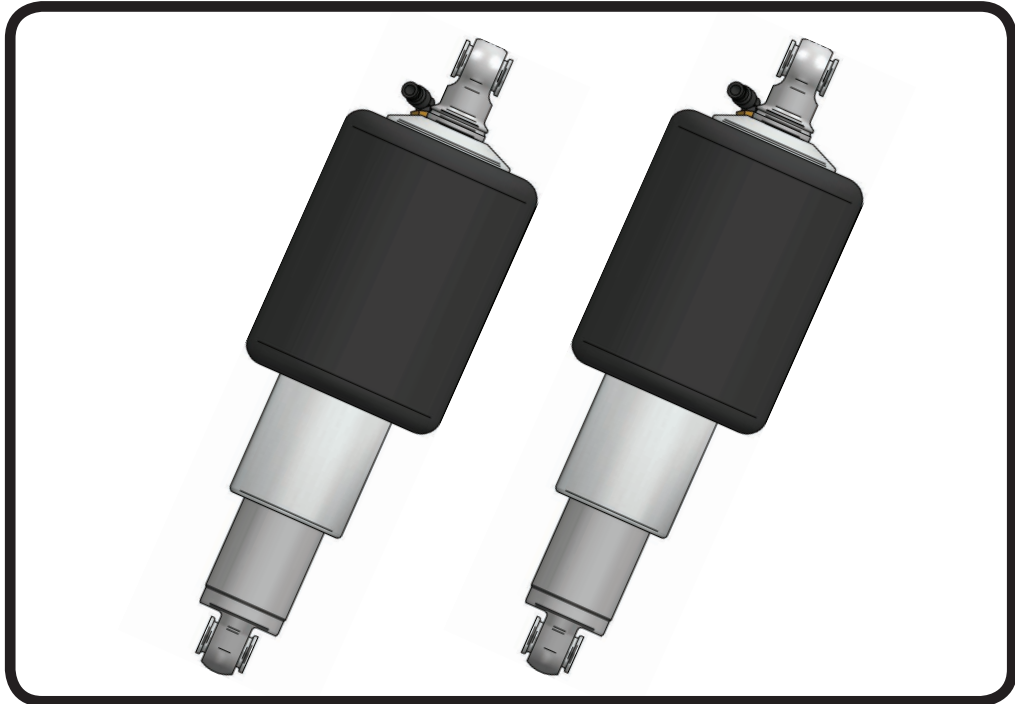

Recommended Tools



7000 Series Bellow, Eye/Eye 5.2" Shock Installation Instructions

Table of contents

Page 36..... Included components

Page 37..... Notes and Care of Your Shockwave

Page 38..... Shock Adjustment

ShockWave Dimensions:

Center of bearing to Center of bearing:	
Compressed:	11.85"
Ride Height:	14.60"
Extended:	16.42"



Major ComponentsIn the box

Item #	Part #	Description	QTY
1	24159999	5.2" Stroke HQ Series Shock	2
2	90002024	Shock Eyelet	2
3	24090799	7000 Series, 4" Diameter AirSpring	2
4	70008193	AirSpring Locking Ring (Installed on Shock)	2
5	90002044	Spacer kit - 1/2" ID and 5/8" ID	4
	90001994	5/8" ID Bearing (installed in shock and eyelet)	4
	90001995	Bearing Snap Ring (installed in shock and eyelet)	8

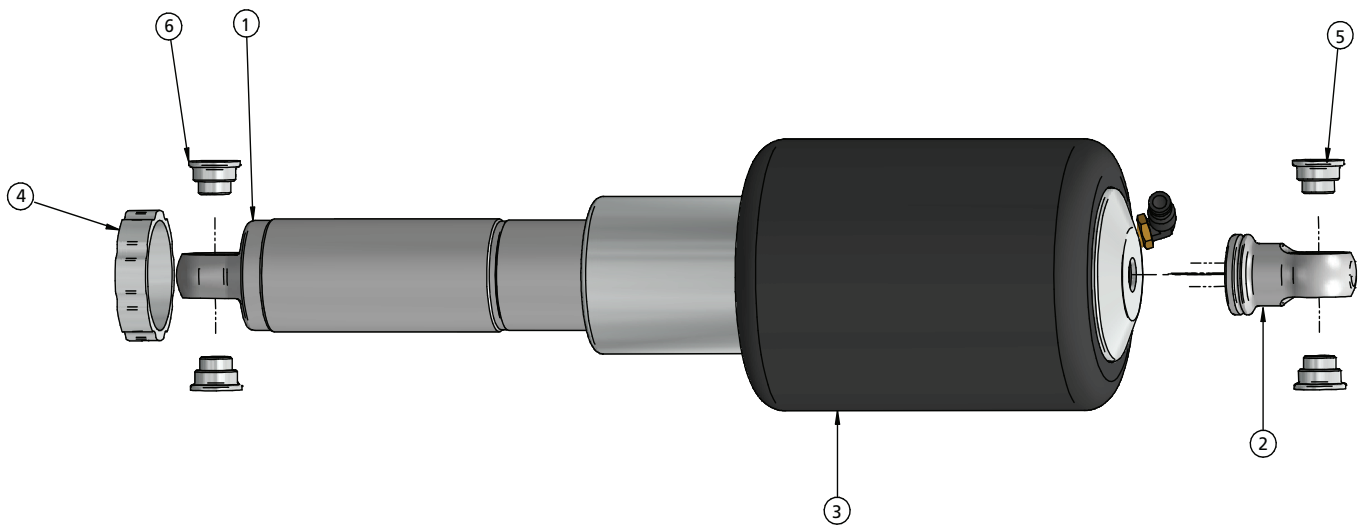

WARNING: ATTEMPTING TO REMOVE THE AIR FITTING WILL DAMAGE IT AND VOID THE WARRANTY.



Notes and Care of your Shockwaves

NOTES:

WARNING: ATTEMPTING TO REMOVE THE AIR FITTING WILL DAMAGE IT AND VOID THE WARRANTY.

You can clock the airfitting location on the ShockWave by turning the AirSpring assembly of the shock. Make sure the fitting doesn't contact the frame.

When cutting the airline, use a razor blade. The cut needs to be a clean cut and square for the airline to seal properly.

The Locking ring on the shock is **NOT** adjustable. These rings are set at the factory to optimize the AirSpring stroke with the shock stroke.

The care and feeding of your new ShockWaves

1. Although the ShockWave has an internal bumpstop, **DO NOT DRIVE THE VEHICLE DEFLATED RESTING ON THIS BUMPSTOP. DAMAGE WILL RESULT.** The internal bumpstop will be damaged, the shock bushings will be damaged, and the vehicle shock mounting points may be damaged to the point of failure. This is a non warrantable situation.
2. Do not drive the vehicle overinflated or "topped out". Over a period of time the shock valving will be damaged, possibly to the point of failure. This is a non warrantable situation! If you need to raise your vehicle higher than the ShockWave allows, you will need a longer unit.
3. The ShockWave is designed to give a great ride quality and to raise and lower the vehicle. **IT IS NOT MADE TO HOP OR JUMP!** If you want to hop or jump, hydraulics are a better choice. This abuse will result in bent piston rods, broken shock mounts, and destroyed bushings. This is a non warrantable situation.
4. Do not let the ShockWave bellows rub on anything. Failure will result. This is a non warrantable situation.
5. The ShockWave product has been field tested on numerous vehicles as well as subjected to many different stress tests to ensure that there are no leakage or durability problems. Failures have been nearly nonexistent unless abused as described above. If the Shockwave units are installed properly and are not abused, they will last many, many years. ShockWave units that are returned with broken mounts, bent piston rods, destroyed bumpstops or bushings, or abrasions on the bellows will not be warrantied.



Shock Adjustment

Shock adjustment 101- Single Adjustable

Rebound Adjustment:

How to adjust your new shocks.

The rebound adjustment knob is located on the top of the shock absorber protruding from the eyelet.

You must first begin at the ZERO setting, then set the shock to a soft setting of 20.



-Begin with the shocks adjusted to the ZERO rebound position (full stiff). Do this by rotating the rebound adjuster knob clockwise until it stops.



-Now turn the rebound adjuster knob counter clock wise 20 clicks. This sets the shock at 20. (settings 21-24 are typically too soft for street use).

Take the vehicle for a test drive.



-if you are satisfied with the ride quality, do not do anything, you are set!

-if the ride quality is too soft increase the damping effect by rotating the rebound knob clock wise 3 clicks. **CONTINUE ON NEXT PAGE.**

Take the vehicle for another test drive.



-if the vehicle is too soft increase the damping effect by rotating the rebound knob clock wise 3 additional clicks.



-If the vehicle is too stiff rotate the rebound adjustment knob counter clock wise 2 clicks and you are set!

Take the vehicle for another test drive and repeat the above steps until the ride quality is satisfactory.