

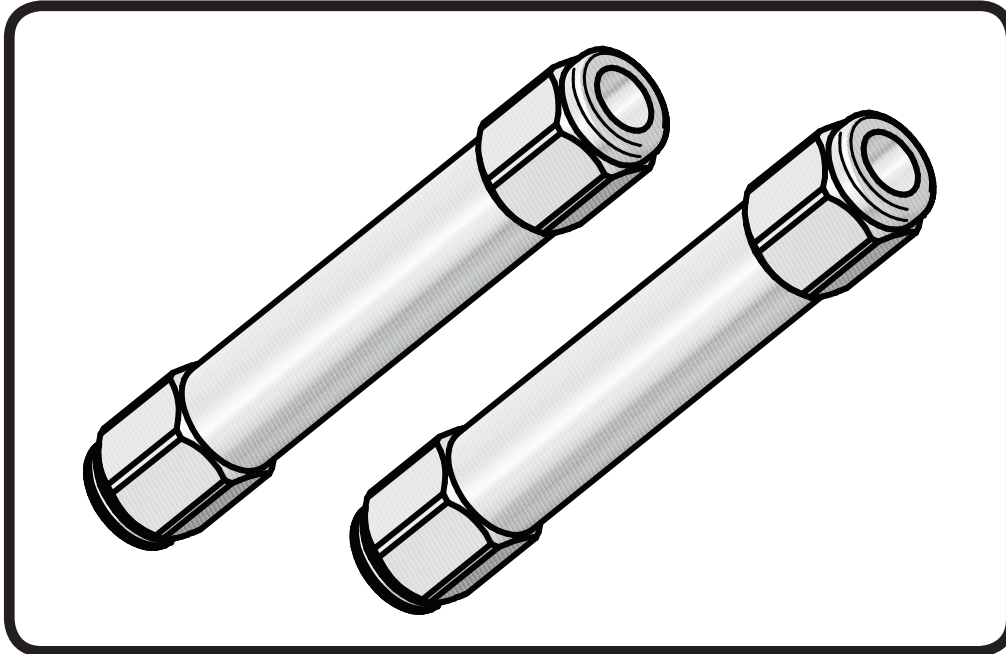

Part # 11379400 - 1988-1998 GM C1500 Tie Rod Adjuster

Recommended Tools



Major ComponentsIn the box

QTY	Part Number	Description
2	90000092	Tie Rod Adjuster
2	99800000	1 1/16" -16 Right Hand Jam Nut
2	99800001	1 1/16" -16 Left Hand Jam Nut

NOTES:

This Tie Rod Adjuster is designed to take place of the OEM steel sleeve.

One end of the adjuster has a **groove** cut in it, this is the **LEFT HAND** threaded side.

When installing the Tie Rod Adjuster, use antisieze compound on the threads.

USE THE SIGHT HOLE IN THE SIDE OF THE TIE ROD ADJUSTER TO ENSURE PROPER THREAD ENGAGEMENT.