

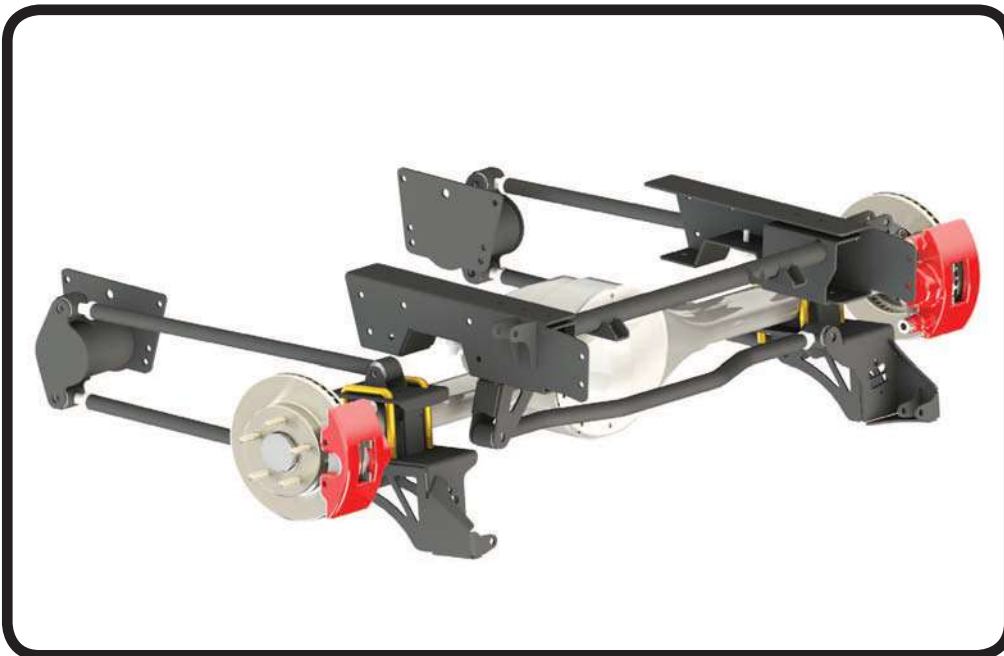

Part # 11367199 - 1973-1987 C10 Rear 4Link

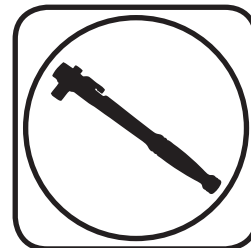

Recommended Tools

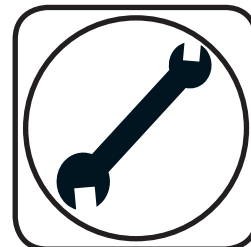

1973-1987 C-10 Rear 4Link Installation Instructions

Table of contents

Page 2-3.....	Included Components
Page 4.....	Hardware List & Getting Started
Page 5.....	Disassembly
Page 6.....	"C" Notch Installation
Page 7.....	Upper Cross Member Installation
Page 8.....	Frame Mount & Axle Mount Installation
Page 9.....	Installing Lower Axle Mount & 4Link bars
Page 10.....	Installing Panhard bar and Shockwave/CoilOvers
Page 11.....	Finishing



Major ComponentsIn the box

Item #	Part #	Description	QTY
1	90000668	Upper Crossmember	1
2	90000670	Driver C-Notch	1
3	90000671	Passenger C-Notch	1
4	90002746	Driver Lower Axle Bracket	1
5	90002748	Passenger Lower Axle Bracket	1
6	90000952	Panhard Bar - Set to 33 1/2"	1
7	90000673	Upper Axle Bracket	2
8	90000666	4Link Frame Mount - Driver	1
9	90000667	4Link Frame Mount - Passenger	1
10	90002824	4Link Bars - Set to 26 1/2"	4
11	70013364	R-Joint Rod End	5
	70013882	Panhard R-Joint Spacers - .625" ID x .740" Long	2
12	90001086	Panhard Bushings - Pressed into Panhard Bar Frame End	2
	90002895	Panhard Bushing Inner Sleeve - pressed into 90001086	1
	70013334	4Link Bar R-Joint Spacer .625" ID x .620" Long	16
	70013495	U-Bolt - 5/8-18 x 3.13 x 5.5 (Not Shown)	4
	90002043	Shockwave/Coilover Spacers (Not Shown) .500" ID	8
	99752004	3/4"-16 Jam Nut - Installed on Bars	5
	70013322	Short Bumpstops with Hardware	2
R-Joint Components - (Installed in bar ends)			
	70013279	Retaining Ring	9
	70013280	Wavo Wave Spring	9
	70013275	R-Joint Center Ball	9
	70013276	R-Joint Composite Center Ball Cage	9



Major ComponentsIn the box

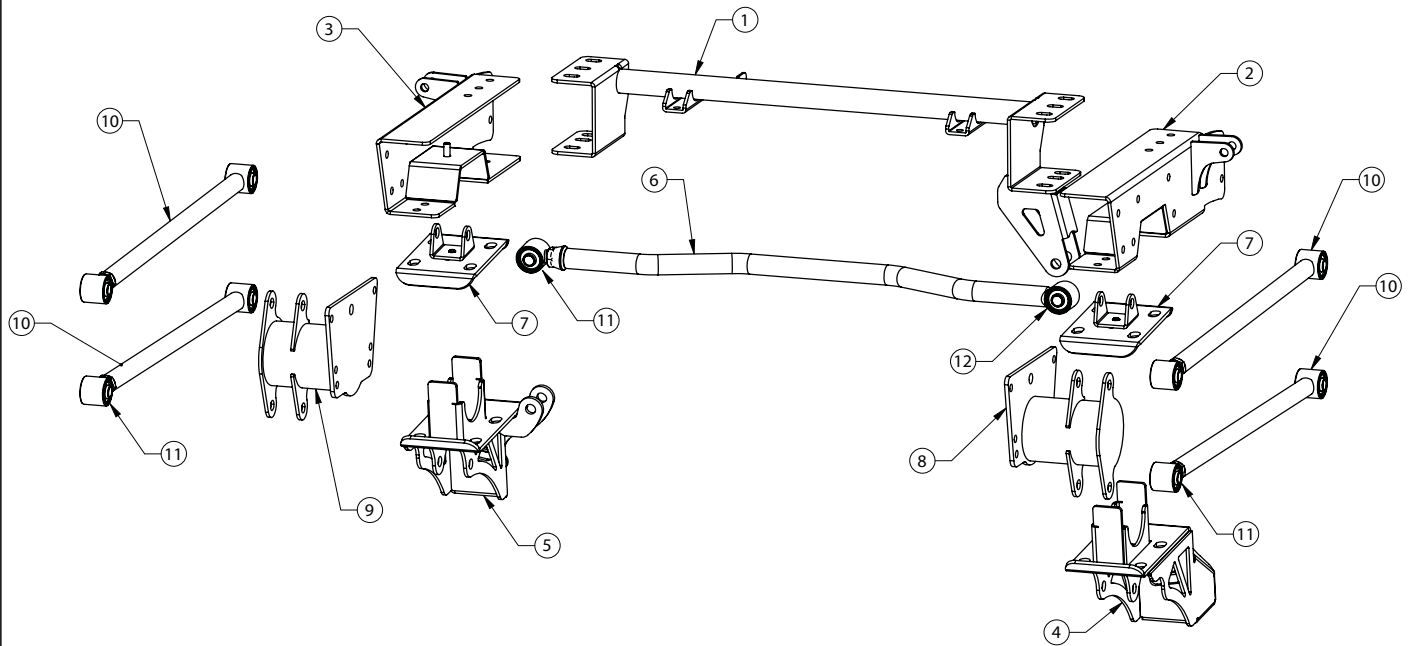

R-JOINT SPACER INSTALLATION

Install the Spacers by inserting the SMALL side of the SPACER into the Center Pivot Ball. Push them in until they bottom out and stop.

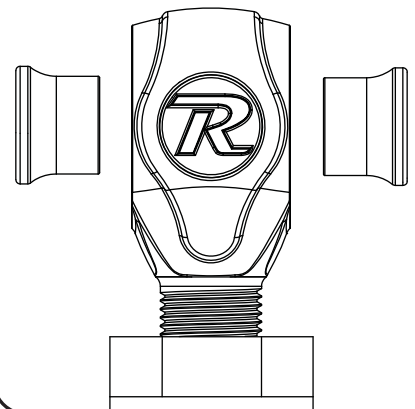



Hardware ListIn the box (Kit# 99010014)

The Hardware Kit contains bags to help aid in selecting the correct hardware for the component being installed. The hardware list shows how the hardware is bagged.

QTY	Part Number	Description	USAGE
4LINK BARS & PANHARD BAR			
8	99621004	5/8" x 3" SAE Gr. 8 Bolt	4Link Bars
2	99621018	5/8" x 3 1/4" SAE Gr. 8 Bolt	Panhard Bar
10	99622006	5/8" SAE Nylok Jam Nut	4Link Bars & Panhard Bar
20	99623001	5/8" SAE Flat Washer	4Link Bars & Panhard Bar
FRONT 4LINK BAR MOUNT			
12	99431002	7/16" x 1 1/4" USS Bolt	Front 4Link Bar Mount to Frame
24	99433002	7/16" SAE Flat Washer	Front 4Link Bar Mount to Frame
12	99432001	7/16" USS Nylok Nut	Front 4Link Bar Mount to Frame
AXLE BRACKET TO AXLE			
8	99622001	5/8" SAE Nylok Nut	Axle Bracket to Axle
16	99623001	5/8" SAE Flat Washer	Axle Bracket to Axle
"C" NOTCH MOUNTING - SIDE & FRONT LOWER			
24	99431002	7/16" x 1 1/4" USS Bolt	"C" Notch to Frame - Side & Front Lower
24	99432001	7/16" USS Nylok Nut	"C" Notch to Frame - Side & Front Lower
48	99433002	7/16" SAE Flat Washer	"C" Notch to Frame - Side & Front Lower
BRAKE LINE BRACKET			
12	99431008	7/16" x 1 1/2" USS Bolt	"C" Notch to Frame - Rear Top & Bottom
12	99432001	7/16" USS Nylok Nut	"C" Notch to Frame - Rear Top & Bottom
24	99433002	7/16" SAE Flat Washer	"C" Notch to Frame - Rear Top & Bottom
BRAKE LINE BRACKET			
1	99311002	5/16" x 1 1/4" USS Bolt	Brake Line Bracket
1	99312003	5/16" USS Nylok Nut	Brake Line Bracket
2	99313002	5/16" SAE Flat Washer	Brake Line Bracket
SHOCK MOUNTING			
4	99501050	1/2" x 2 1/2" USS Bolt Gr. 8	Shocks to Mounts
4	99502009	1/2" USS Nylok Nut Gr. 8	Shocks to Mounts
8	99503012	1/2" SAE Flat Washer Gr. 8	Shocks to Mounts



Disassembly

Congratulations on your purchase of the Ridetech Rear 4Link System. This system has been designed to give your truck excellent handling along with a lifetime of enjoyment. Some of the key features of this system: C-notches to give your suspension the travel it needs at the lowered height, 4Link setup to replace the leaf spring, this provides better control of the rear axle, long panhard bar to reduce the side-to-side movement of the differential, and the biggest feature of all, it allows the use of Shockwaves or CoilOvers.

Note: This system is designed for use with the Ridetech Shockwaves or CoilOvers and the MuscleBar swaybar. **The factory shocks and springs or the factory sway bar will not fit this 4Link.**

1. Raise the vehicle to a safe and comfortable working height and support it by the frame. You will need to be able to move the rear differential up and down. Let the rear suspension hang freely.
2. **Remove the bed.**
3. Raise the axle a couple inches and support it so that it cannot rotate. Remove the leaf springs and shock absorbers. Refer to the factory service manual for proper disassembly procedures.



4. The Brake Line Bracket will need to be removed from the passenger side frame rail. This will require separating the steel line from the rubber line at the bracket. There is a provision for the brake line in the upper bridge of the 4 link kit. Cap the line off to help prevent the brake fluid from draining out of the line. Remove the bracket by removing the rivets. We like to use a die grinder to cut a "+" in the head of the rivet. We then knock the head off with a hammer and chisel or an air chisel. With the head removed, knock the rivet out of the bracket and frame.

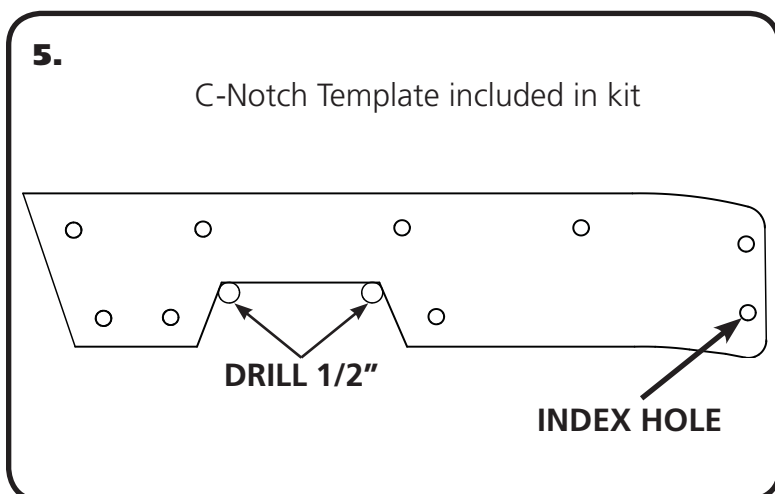

5. To allow maximum drop on this truck the frame must be notched. The template for the notch will locate off of the index hole shown below. Use the supplied "C" Notch template to mark out the frame for cutting. Before cutting out the frame, support the frame in front of and behind the "C" Notch area. We suggest doing one side at a time. The "C" Notch template has an arrow pointing to the front of the truck. Use the "Index Hole" in the back side of the template to help locate the Template.



"C" Notch Installation

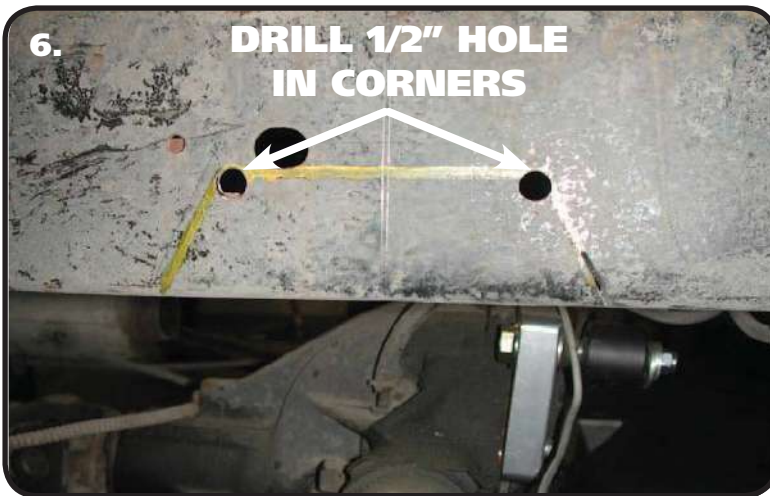

6. Use the supplied Template to mark the cut lines on the frame, then drill out the two corners with a 1/2" drill bit. This will give the cut a round edge and eliminate the possibility for stress fractures. Then cut the notch with a saw-z-all, cutoff wheel or plasma cutter. Grind all edges smooth.

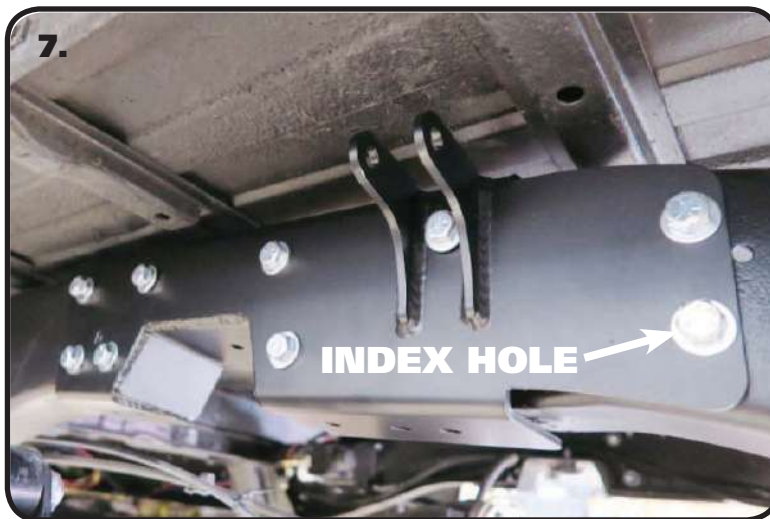

7. Slide the C-Notch in place making sure the "Index Hole" is aligned. If it doesn't align, you may need to trim the C-Notch opening you cut in the frame. Once you have the C-Notch fitting properly, use it for a template to drill the attaching holes in the frame. Drill the holes in the side of the frame and also the top and bottom of the frame. Use a 7/16" drill bit to drill these. You will have to drill out the "Index Hole" to 7/16" too. Install a 7/16" Flat Washer onto (12) 7/16"-14 x 1 1/4" bolts. Insert the bolts/washers into the drilled holes leaving the bolts out of the rear 3 holes on the top and bottom of the C-Notch. Install a 7/16" Washer and 7/16" Nylok Nut on each of the bolts sticking through the frame and tighten to 50 ftlbs. Repeat steps 5-7 on other side.



8. Install the bumpstops into the "C" Notches using a 3/8" nut and flat washer. Tighten the hardware enough to hold the bumpstop in place.



Upper Cross Member Installation



9. After both C-Notches have been installed, the Upper Cross Member can be installed. The Cross Member is located using the rear 3 holes in the top and bottom of each C-Notch. The Panhard bar mount is located on the driver's side of the Cross Member. The Cross Member attaches underneath the Frame on the top, and underneath the C-Notch on the bottom. Install a 7/16" Flat Washer on (12) 7/16" x 1 1/2" Hex Bolts and insert them into each of the (12) holes. Install all of the bolts with the Nylok Nuts inside the frame. Install a 7/16" Flat Washer & 7/16" Nylok Nut on each of the (12) Bolts and tighten to 50 ftlbs.



10. Attach the rubber brake line to the Upper Cross Member using the OEM clip. You may have to tweak the steel brake line to reposition it to thread into the rubber brake line. Thread the steel brake line into the rubber brake line and tighten.

YOU WILL NEED TO BLEED THE REAR BRAKES BEFORE DRIVING THE TRUCK!!



11. The OEM front leaf spring mounts will need to be removed from the frame rail. This can be done by either drilling the rivets out or removing the rivet heads and driving them out. We remove the rivet heads by cutting a " + " in the head with a die grinder then we cut the head off with a hammer and chisel or with an air chisel. Once the head is removed, the rivet can be driven out with a hammer and punch. After removing the frame mounts, drill the rivet holes with a 7/16" drill bit.



Frame Mount & Axle Mount Installation



12. The Bar Mounts bolt in place of the OEM front leaf spring mount. There is a Driver and Passenger Mount. **Image 12** shows the Driver Mount. The Tabs are to the FRONT of tube. Install a 7/16" Flat Washer on (6) 7/16" x 1 1/4" Bolts. Hold the Mount in place and insert the bolts/washer through the mount and frame. Install a 7/16" Flat Washer and 7/16" Nylok Nut on each bolt sticking through the frame and tighten to 50 ftlbs. Repeat on the other side.

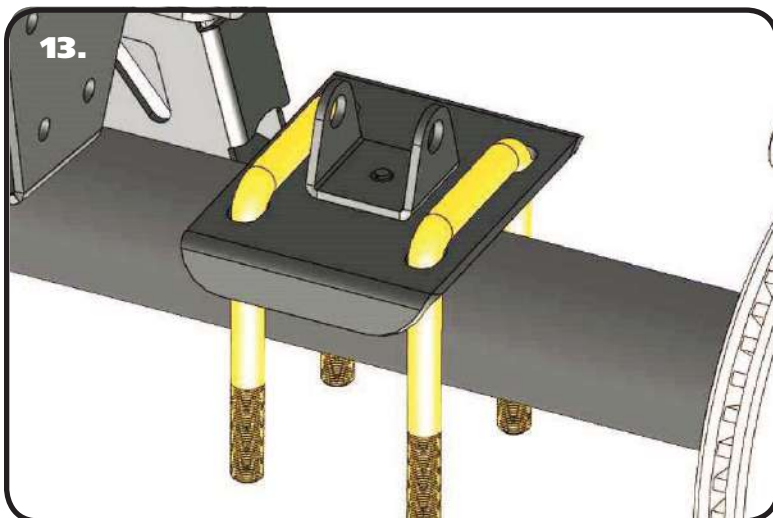

13. The Kit includes 2 Upper Bar Mounts that are the same. Each one sits on a leaf spring pad with the center pin indexed into the center hole of the leaf spring pad. Sit an Upper Bar Mount on top of the axle with the locating pin into the center hole of the leaf spring pad. Install a 5/8" Square U-bolts through each pair of side holes in the Upper Bar Mount with the threads pointing down. The U-bolts will run parallel to the frame.



14. The Kit includes a Driver and Passenger Lower Axle Mount; the two are different. The Passenger Mount has the Panhard bar mount built into it. Image 13 shows the Driver Mount. Hold the Mount up in place against the bottom of the axle tube. The tabs will nest against the bottom of the leaf spring pad. Make sure the u-bolts drop through the holes in the Lower Mount. Install a 5/8" Flat Washer followed by a 5/8" Nylok Nut on each leg of the U-Bolts. Tighten the Nuts evenly until the Lower Mount is tight against the tube and leaf spring pad. Then torque the Nuts to 60 ftlbs in a crisscross fashion.



Installing Lower Axle Mount & 4Link Bars



15. Repeat the above step on the Passenger Lower Mount. Torque the hardware to 60 ftlbs in a crisscross fashion.



16. This Kit contains (4) 4Link bars that are the same. **Insert the .620" Long R-Joint Spacers into the Center Pivot Ball of the R-Joints in the bars as shown on Page 3.** Each Bar is attached with a 5/8" x 3" Bolt, 5/8" Nylok Jam Nut, & (2) 5/8" Flat Washers. Install a 5/8" Flat Washer on each of the 5/8" x 3" Bolts. Attach the front of the bars to the frame mounts first. Do this by holding the Bar in position and insert the 5/8" Bolt/Washer through the Mount and Bar End. Install a 5/8" Flat Washer followed by a 5/8" Nylok Jam Nut on the threads of the bolt. Install all of the Bars before tightening the Hardware.



17. Attach the rear of the Bars to the Axle Mounts. The upper bar gets installed in the Upper Axle Bracket, the lower bar gets installed in the Lower Axle Bracket. Each Bar is attached using (1) 5/8" X 3" Bolt, (2) 5/8" Flat Washer & (1) 5/8" Nylok Jam Nut. Install a 5/8" Washer on each Bolt before inserting them through the Bar/Bracket. Install a 2nd 5/8" Flat Washer on the threads of the bolt that are sticking out of the bracket followed by a 5/8" Nylok Nut. Tighten the hardware enough to eliminate any gaps.



Installing Panhard Bar and Shockwaves/Coilovers



18.

18. Install the Panhard bar into the frame bracket. The Panhard Bar is a bent bar, it is bent to clear the center section of the rear differential. The bar needs to be mounted with the BEND to the REAR and the Rubber Bushing in the Frame Mount, this will help it clear the differential cover. The Panhard bar is attached using (1) 5/8" x 3 1/4" bolt, (1) 5/8" Nylok Jam Nut & (2) 5/8" Flat Washers. Tighten the hardware enough to eliminate any gaps.

Note: The panhard bar is set at 33 1/2" before it is shipped, but may need adjusted to center the axle at ride height.



19.

19. Install the .740" Long R-Joint Spacers into the Center Pivot Ball of the R-Joint in the Panhard Bar. Install the other end of the Panhard bar into the mount on the Passenger Lower Axle Mount. The Panhard bar is attached using (1) 5/8" x 3 1/4" bolt, (1) 5/8" Nylok Jam Nut & (2) 5/8" Flat Washers. Tighten the hardware enough to eliminate any gaps.

20. Insert a Spacer into each side of the upper Shockwave/CoilOver bearing. Slide the assembly into the upper shock mount. If your shock has an adjuster knob, position it so that the knob points toward the outside of the truck. Line up the hole in the spacers with the hole in the upper shock mount and insert 1/2" x 2 1/2" bolt and 1/2" Nylok nut with a 1/2" SAE Flat Washer on each side of the mount.

Note: If installing Shockwaves and you want to locate the air fitting in a different location, the air spring assembly can be rotated on the shock by grabbing the shock and air spring assembly by hand and spinning the shock in the air spring assembly.



20.

SPACER



Finishing

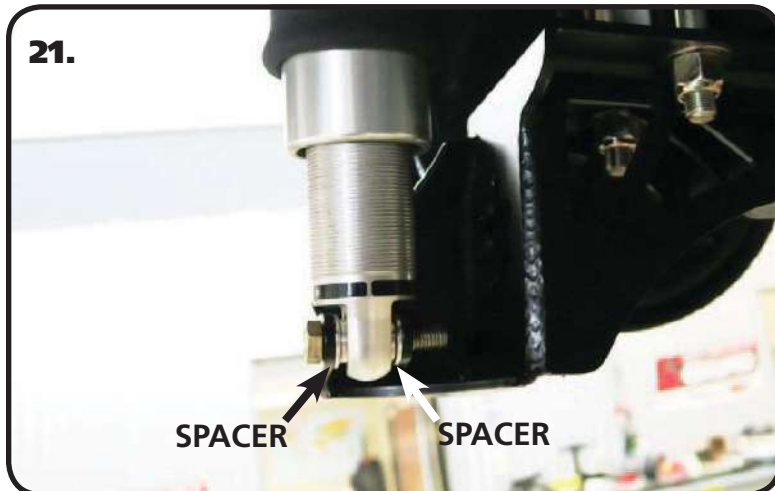

21. Insert a Spacer into each side of the lower Shockwave/CoilOver bearing. Slide the shock, with the spacers installed, into the mount on the Lower Axle Mount. You may need to jack the rearend up to line up the holes in the bushings with the 1/2" hole in the shock mounts and hold it in place while you install the 1/2" x 2 1/2" Bolt and 1/2" Nylok Nut with a 1/2" SAE Flat Washer on each side of the mount. Tighten the upper and lower shock bolts to 75 ftlbs.

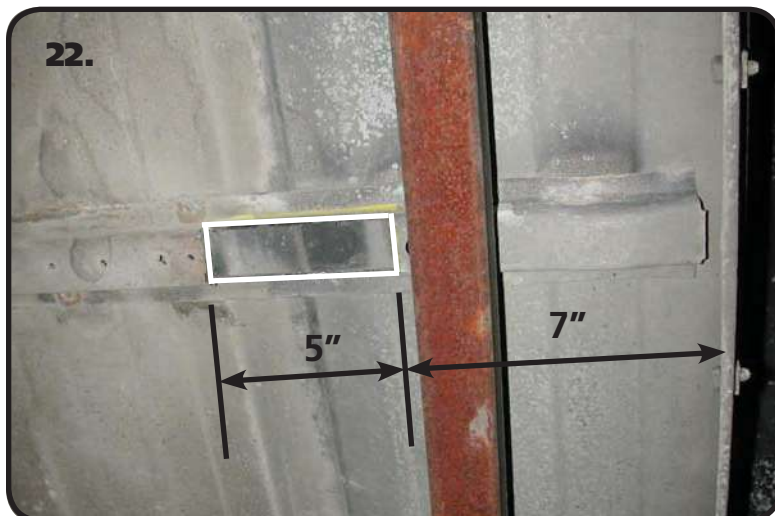

22. To allow clearance for the C-Notch, a section of the bed floor brace that is above the axle must be removed. This section is approximately 5" wide and about 7" from the fender well.

23. Tighten all fasteners. If you are going to install the Ridetech MuscleBar, now is a good time to do it. Reinstall the bed and set the truck back on the ground.

24. Set ride height on the truck. The ride height of the Shockwave/CoilOver is approximately 14 1/2". If you are using Shockwaves, this is done by changing the air pressure in the Shockwaves. If you are using CoilOvers, the ride height is done by using the adjuster nut for the coil spring. The coil spring on the CoilOver will have some preload in the spring to get ride height, this is normal.

25. Measure to make sure the axle is centered at ride height. We prefer to measure between the frame and wheel. Make sure you are measuring the truck in the same location on both sides. If the measurements are off more than 1/16", adjust the Panhard Bar to center the differential.

BLEED THE REAR BRAKES!!!



Part # 11360201 - 73-87 C10 CoilOver System

Front Components:

11362699	Front StrongArm System
11369300	Front Spindles and Caliper Brackets
11363510	Front Coilovers
11369100	Front MuscleBar

Rear Components:

11367199	Rear StrongArm System
11366510	Rear Coilover Instructions

Miscellaneous Components:

85000000	Spanner Wrench
----------	----------------

Recommended Tools

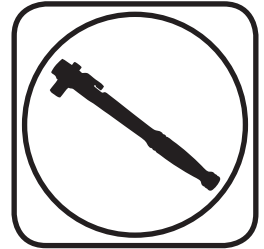
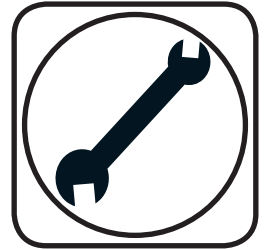

73-87 C-10 Coilover System Installation Instructions

Table of contents

Pages 2-14.....	Front StrongArm System
Pages 15-16.....	Front Coilovers
Pages 17.....	Spindles
Pages 18-21.....	Front MuscleBar
Pages 22-32.....	Rear 4 Link Kit
Pages 33-34.....	Rear CoilOver
Pages 35-36.....	Coilover Assembly and Adjustment



Part # 11362699 - 1973-1987 C10 StrongArms



Recommended Tools



1973-1987 C-10 StrongArms Installation Instructions

Table of contents

Page 3.....	Included components
Page 4.....	Upper Control Arm Components
Page 5.....	Lower Control Arm Components
Page 6.....	Hardware List and Getting Started
Page 7.....	Installing Upper Control Arm Mount
Page 8.....	Installing Upper Control Arm Mount and Upper Arm
Page 9.....	Caster Explained
Page10.....	Offset Upper Cross Shaft
Page11.....	Installing Upper and Lower Control Arm
Page12.....	Installing CoilOver Assembly
Page13.....	Finishing and Alignment
Page14.....	Crossmember Trimming Template



Major ComponentsIn the box

Item #	Part #	Description	QTY
1	90002437	Driver Upper Control Arm	1
1	90002438	Passenger Upper Control Arm (Not Shown)	1
2	90002384	Driver Lower Control Arm	1
2	90002385	Passenger Lower Control Arm (Not Shown)	1
3	90002386	Driver Upper Control Arm Mount	1
3	90002387	Passenger Upper Control Arm Mount (Not Shown)	1
4	90000726	Driver Bumpstop Plate	1
4	90000727	Passenger Bumpstop Plate (Not Shown)	1
5	90001083	Bumpstop	2
	90002062	Coilover Spacers (Not Shown)	8

Driver Side Shown

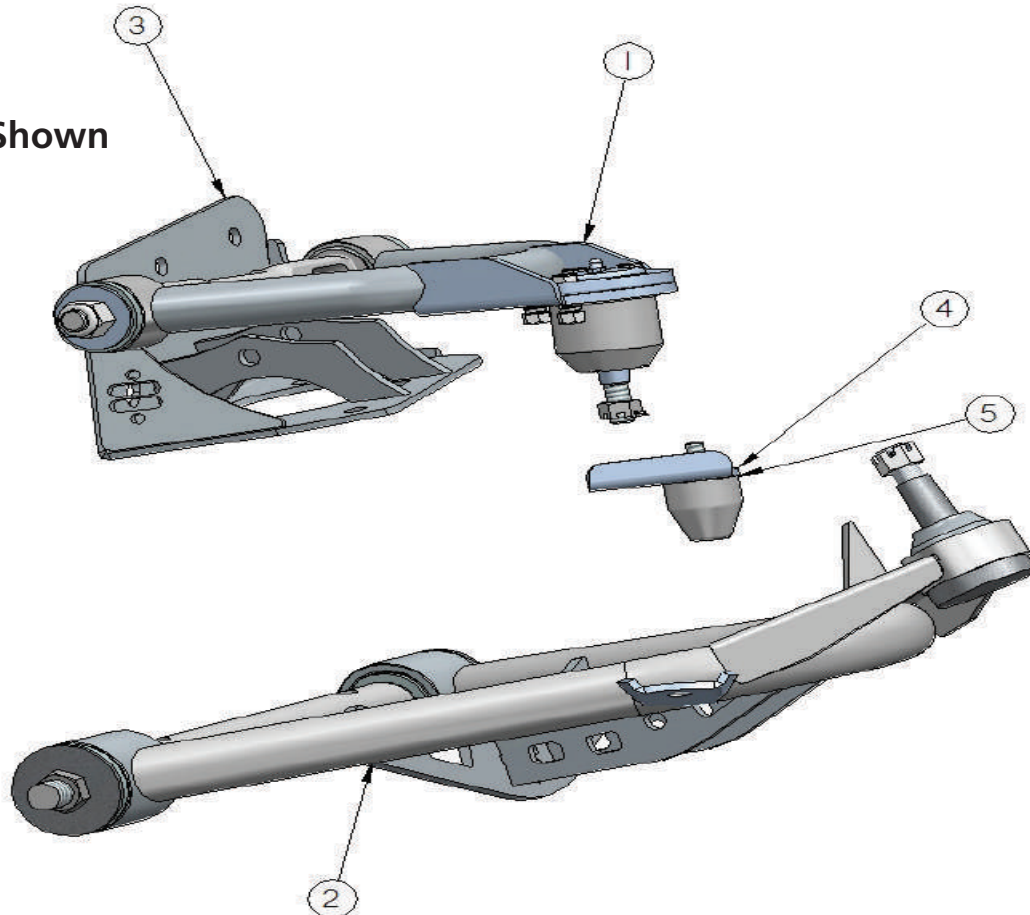



Upper Control Arm ComponentsIn the box

Item #	Part Number	Description	QTY
1	90000910 Kit	Upper Balljoint Assembly	2
2	90000910 Kit	5/16"-24 x 1" Hex Head Bolt	8
3	90000910 Kit	5/16" Lockwasher	8
4	90000910 Kit	5/16"-24 Hex Nut	8
5	90002388	Driver Upper Control Arm (Shown)	1
5	90002389	Passenger Upper Control Arm	1
6	70010826	Inner Delrin Bushing - No Ledge	2
7	70010759	Outer Delrin Bushing	4
8	90000914	Caster Adjustable Upper Control Arm Shaft	2
9	70010882	Caster Slug	4
10	90002737	Delrin Bushing T-Washer	4
11	99622005	5/8 - 18 Locknut (included with 90000914)	4
12	70010827	Inner Delrin Bushing - with Ledge	2

Driver Side Shown

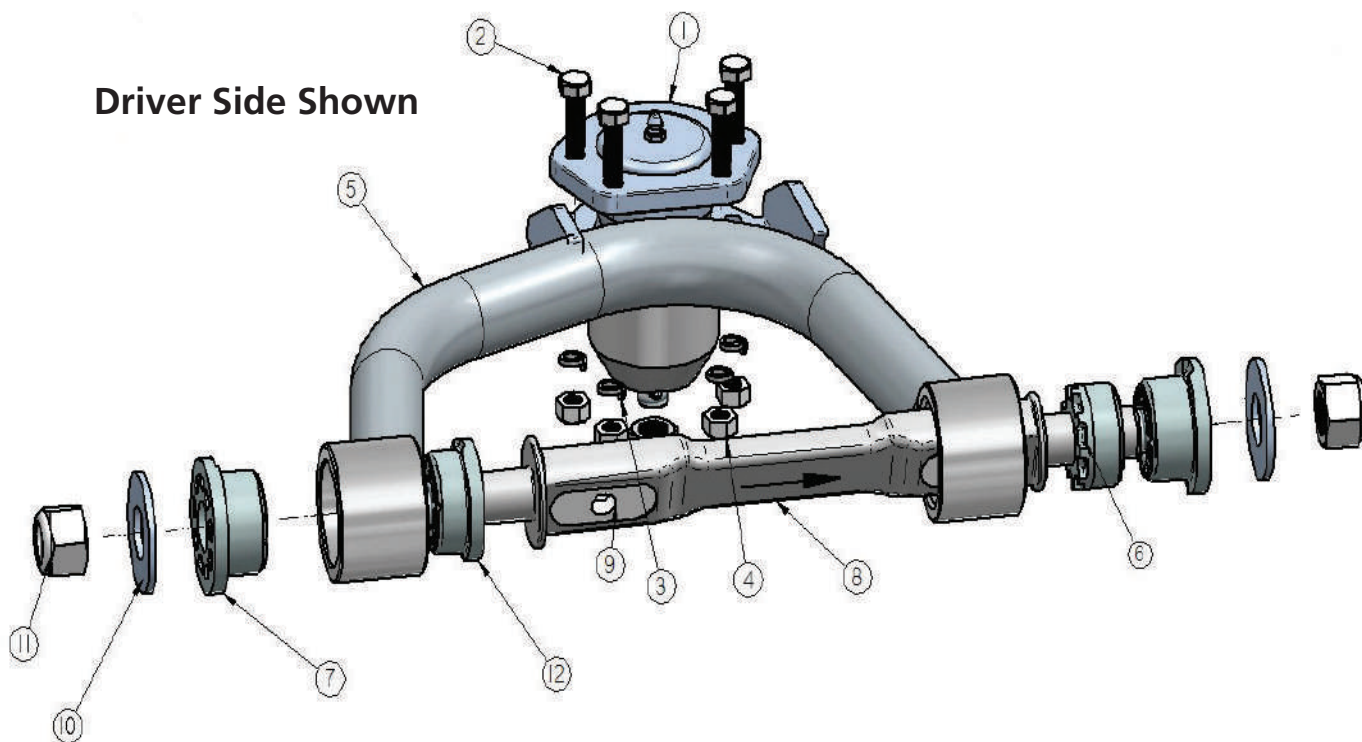



Lower Control Arm ComponentsIn the box

Item #	Part Number	Description	QTY
1	90002384	Driver Lower Control Arm (Shown)	1
1	90002385	Passenger Lower Control Arm	1
2	90002430	Lower Control Arm Cross Shaft	2
3	90000909	Lower Balljoint Assembly	2
4	99753001	Flatwasher	4
5	99752005	3/4"-16 Hex Nut	4
6	70010755	Outer Delrin Bushing - with Ledge	4
7	70011465	Inner Delrin Bushing - no Ledge	4

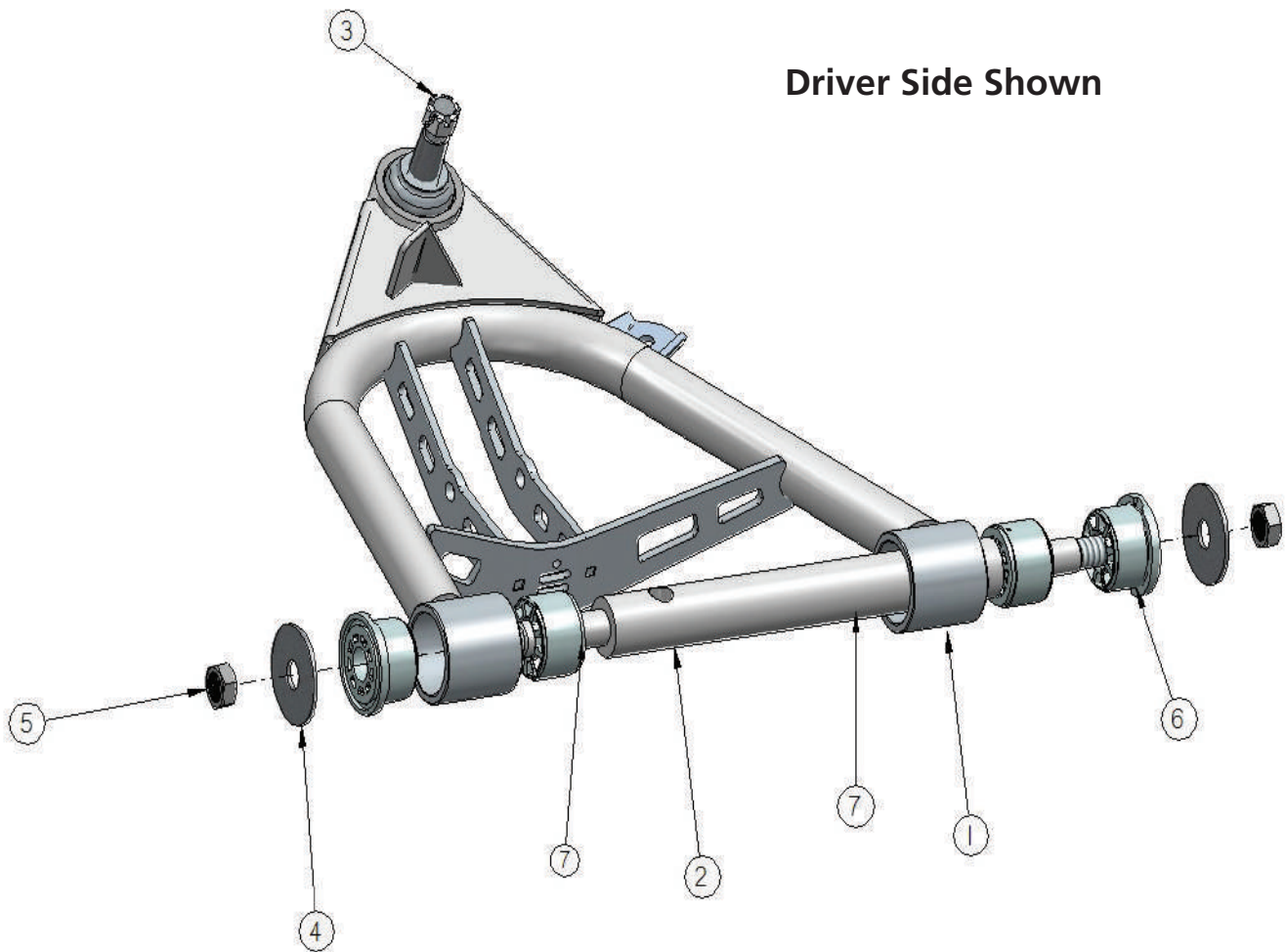



Hardware ListIn the box

QTY	Part Number	Description	
16	99431002	7/16" -14x1 1/4" Hex Bolt	Upper Control Arm Mount
4	99431003	7/16" -14x3" Hex Bolt	Upper Control Arm to Mount
20	99433002	7/16" Flat Washer	Upper Mount to Frame/Control Arm to Mount
20	99432001	7/16" -14 Nylok Nut	Upper Mount to Frame/Control Arm to Mount
4	99501024	1/2" -13x3 1/4" Hex Bolt	Coilover to Arm and Upper Mount
4	99502001	1/2" -13 Nylok Nut	Coilover to Arm and Upper Mount
4	99371006	3/8" -16x1 1/2" Hex Bolt	Bumpstop Mount to Frame
4	99372001	3/8" -16 Nylok Nut	Bumpstop Mount to Frame
8	99373003	3/8" SAE Flatwasher	Bumpstop Mount to Frame

Getting Started.....

Congratulations on your purchase of the Ridetech Strongarm System. These arms have been designed to give your truck excellent handling along with a lifetime of enjoyment. Some of the key features of these StrongArms: Balljoint angles have been optimized for the lowered ride height, Delrin bushings are used for no bushing deflection along with providing free suspension movement through the entire travel. The Delrin bushings are made from a material that is self lubricating so no grease zerks are needed. Upper caster adjustable crossshaft is designed to allow you to run maximum caster angles with minimal shims.

Note: These control arms are designed for use with the Ridetech CoilOvers and the MuscleBar swaybar. **The factory shocks and springs or the factory sway bar will not fit these arms.**

Note: The arms in this kit are designed to be used with 73-87 C-10 Spindles. The 63-87 C-10's have similar control arms through the years, but the balljoints used were different. The year breaks are as follows: 63-70, 71-72, 73-87. Be sure to use the correct balljoint for the year of spindle you are using.

Balljoints:

- 63-70:** Upper-90000911 Lower-90000912
- 71-72:** Upper-90000902 Lower-90000909
- 73-87:** Upper-90000910 Lower-90000909

Installation

1. Remove the entire front suspension from the truck leaving the tie rods connected to the center draglink. Refer to the factory service manual for disassembly procedure. Your original spindle will be reused with this setup, set them to the side for the time being. The original U-bolts for the lower control arms will be reused to fasten your new StrongArms to the frame.



Installing Upper Control Arm Mount

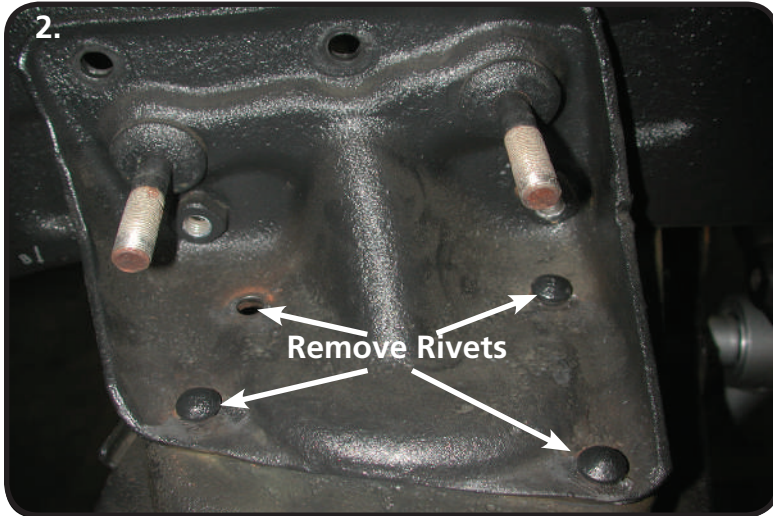

2. The factory upper control arm mount will need to be removed from the frame. There are 4 bolts attaching it to the frame rail with 4 rivets attaching it to the crossmember. There are several methods that can be used to remove the rivets from the crossmember. One way is to cut a "+" in the head of the rivet and chisel the 4 pieces of the head off the rivet, then knock the rivet out of the frame with a hammer and punch.



3. The top side of the crossmember will also need trimmed for clearance. A TEMPLATE IS PROVIDED ON PAGE 13. Cut out the holes in the template and place on top of the crossmember. Trace the template onto the crossmember and cut out the center portion. Your mark should look similar to the one pictured.

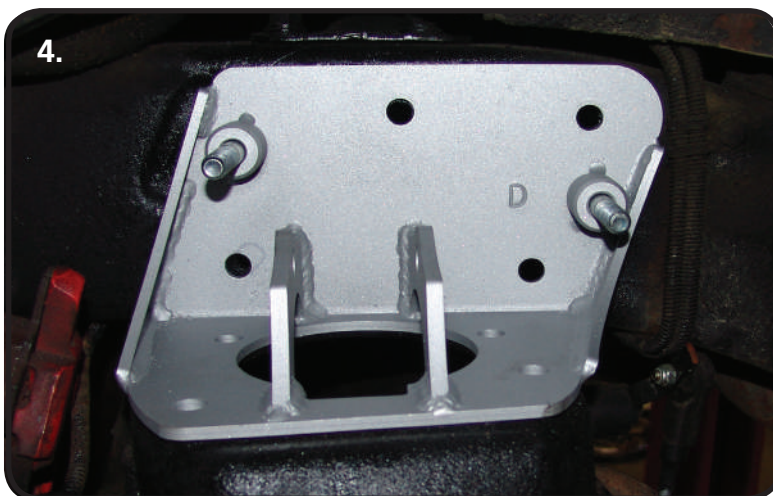

4. Before installing the mount, install the 7/16" x 3" bolts into the upper mount from the back side with the threads pointing towards the wheel side of the bracket. Set the upper control arm mount into position on the frame. The upper brackets are marked D & P for driver & passenger. The brackets get bolted to the frame with 7/16" x 1 1/4" hex bolts and Nylok nuts. The bracket also gets a 7/16" washer under the bolt and under the nut. Do to variances in the frames it may be necessary to drill out the front lower hole. Torque the 7/16" hardware to 50 ftlbs.



Installing Upper Control Arm Mount and Control Arm

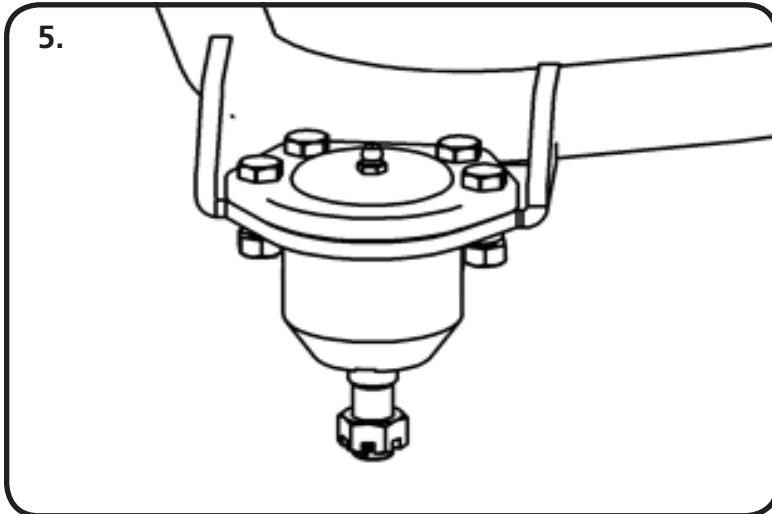

5. Install the balljoints into the upper control arm with the hardware supplied with the balljoint. The upper balljoint goes in from the top side of the control arm. The gussets on the balljoint plate point up. Torque the mounting hardware to 29 ftlbs.

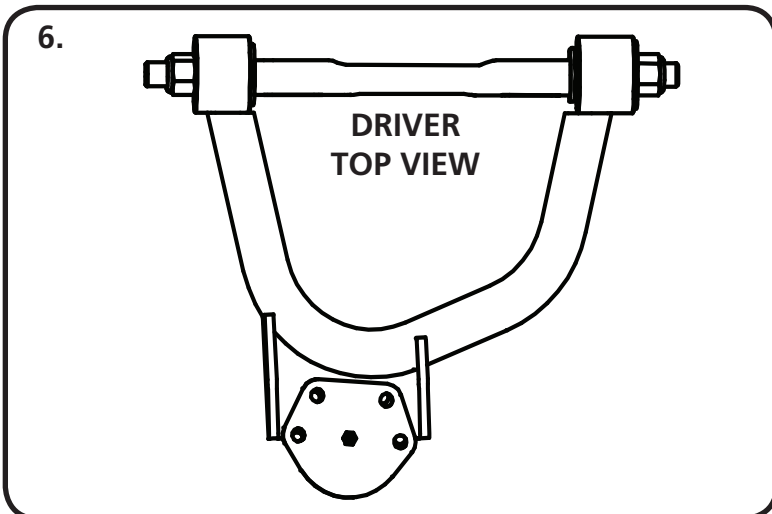

6. Diagram "6" shows the Driver Upper Control Arm. This is looking at the control arm from the top.

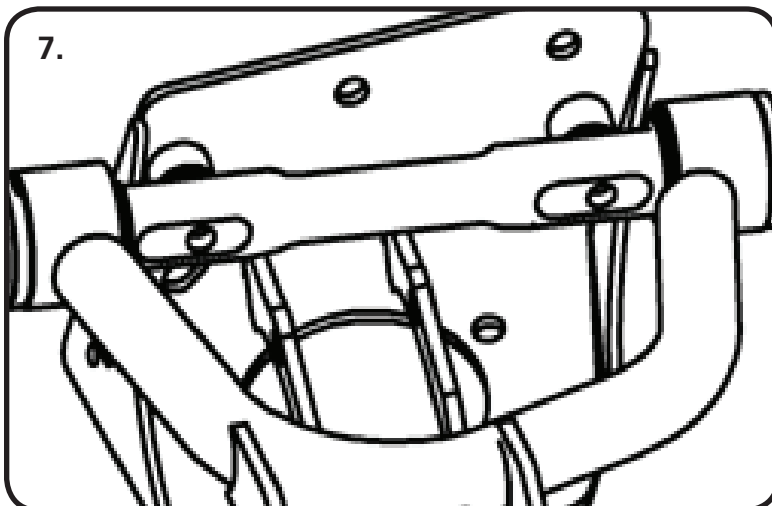

7. Install the caster slugs into the cross shaft. The long side of the caster slug goes to the front of the truck. The cross shaft is attached to the truck using a 7/16" USS Flat Washer & 7/16" Nylok Nut. The drivers side is shown in figure 8. Slide an Aluminum T-washer on each end of the shaft up against the bushing with the FLAT side Toward the locknut. Now install a 5/18"-18 locknut on the shaft. This nut gets snugged up. You want the suspension to be able to move freely.



Caster Explained

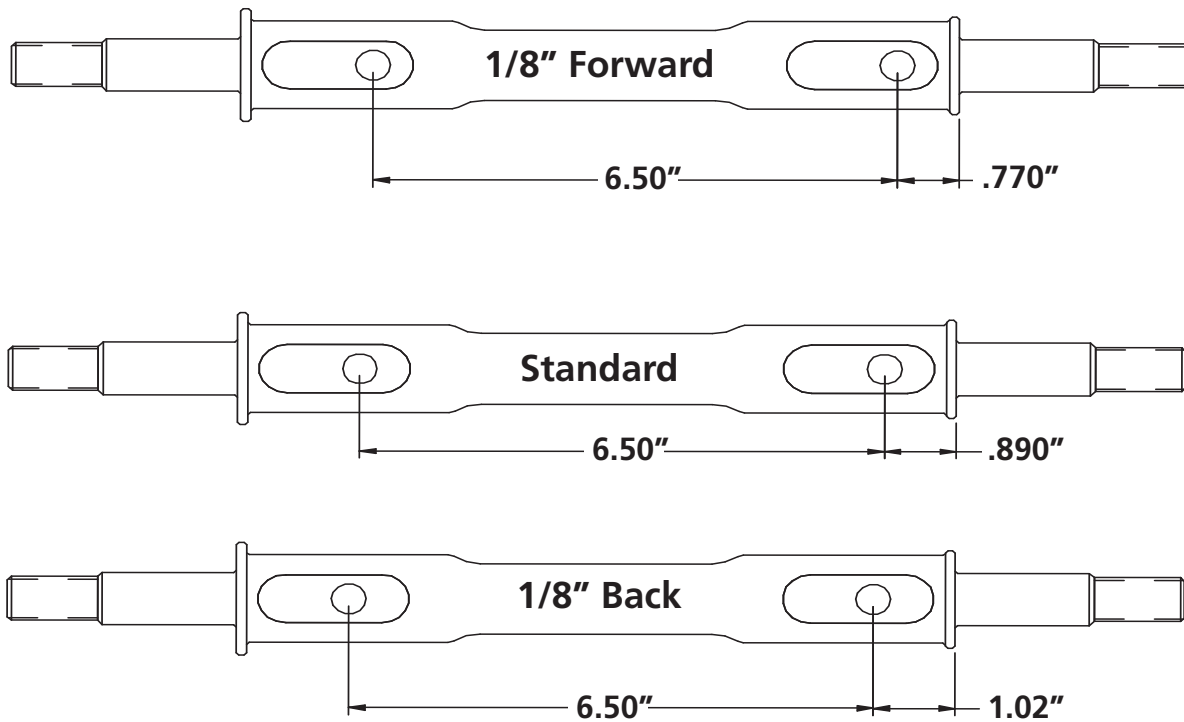

These StrongArms come equipped with a changeable caster slug setup. This allows you to add or remove caster from the front suspension, if desired. The caster slugs that come supplied in the kit are setup to provide approximately 5 degrees of caster. The caster slugs allow you to add or remove caster without having to use a stack of shims. If more or less caster is desired, optional slugs can be purchased from Ridetech or your Ridetech dealer.

Caster Explained:

To understand caster you need to picture an imaginary line that runs through the upper balljoint and extends through the lower balljoint. From the side view the imaginary line will tilt forward or backward. The tilting of this imaginary line is defined as caster.

Caster is measured in degrees by using a caster gauge. If the imaginary line described above tilts towards the back of the vehicle at the top, then you have positive caster. If the imaginary line tilts forward then you have negative caster.

Positive caster provides the directional stability in your vehicle. Too much positive caster will make the steering effort difficult. Power steering will allow you to run more positive caster. Negative caster requires less steering effort but will cause the vehicle to wander down the highway



Offset Upper Control Arm Shaft

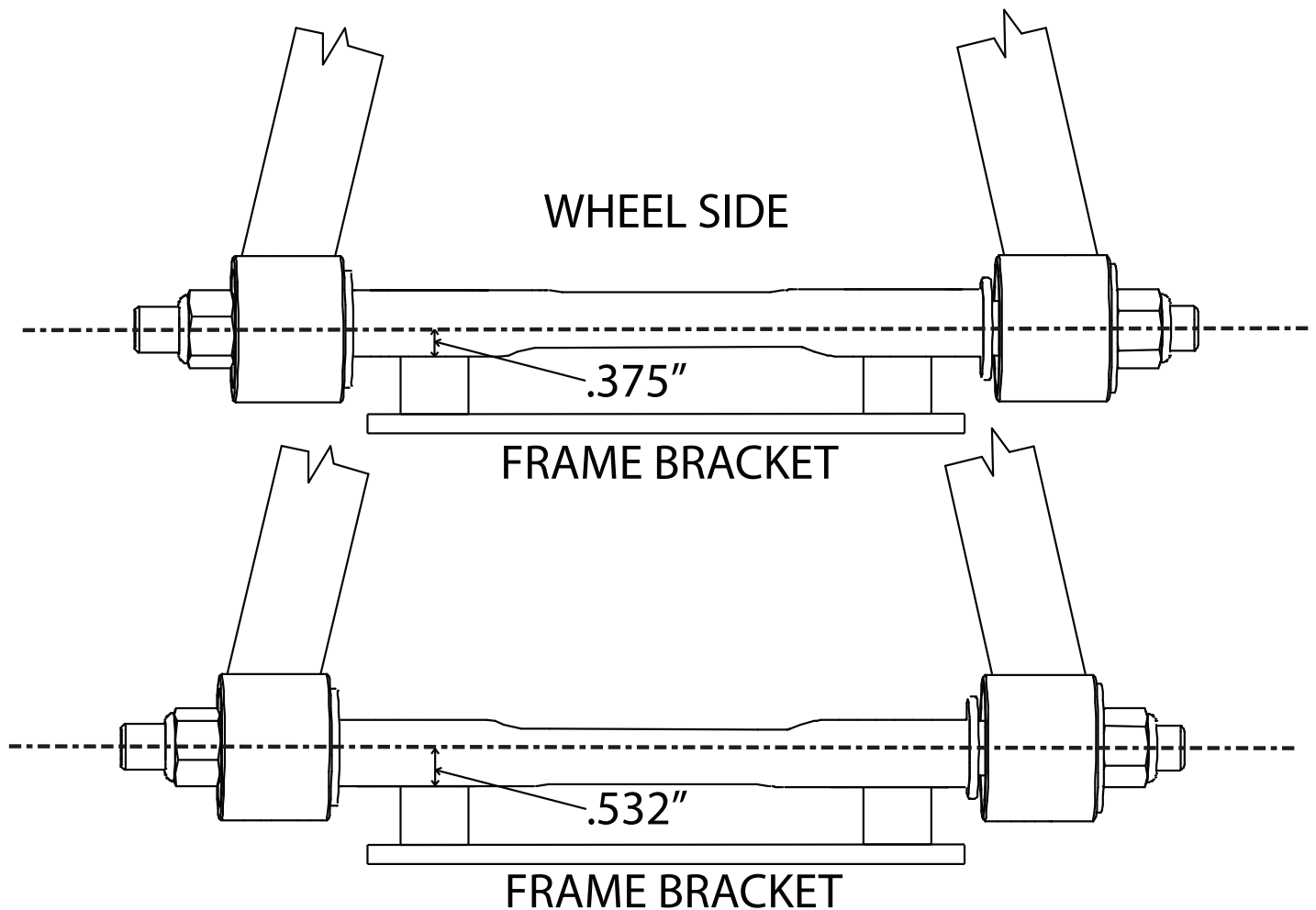

The cross shaft that is used in the upper control arms is offset. The offset combined with the caster slug option allows you to achieve the alignment setting you desire with minimal shims. To change the direction the Icon faces simply spin the cross shaft in the control arm.

If you are after a **Street Alignment** bolt the upper control arm to the frame mount with the arm offset to the outside of the truck. The Ridetech Icon will be facing the wheel.

If a more aggressive **Track or Autocross** alignment is desired, bolt the control arm to the frame bracket with the arm offset to the inside of the truck. The Ridetech Icon will be facing the frame rail.



Installing Upper and Lower Control Arm



8. The lower control arm is installed using the factory U-bolts and nuts. The lower control arm is located by a pin that is in the center of the front u bolt cradle. This pin will go into the hole in the control arm shaft to help locate the control arm.

NOTE: We have ran across some trucks where the rear pin is the locator pin. It will locate the control arm correctly too.

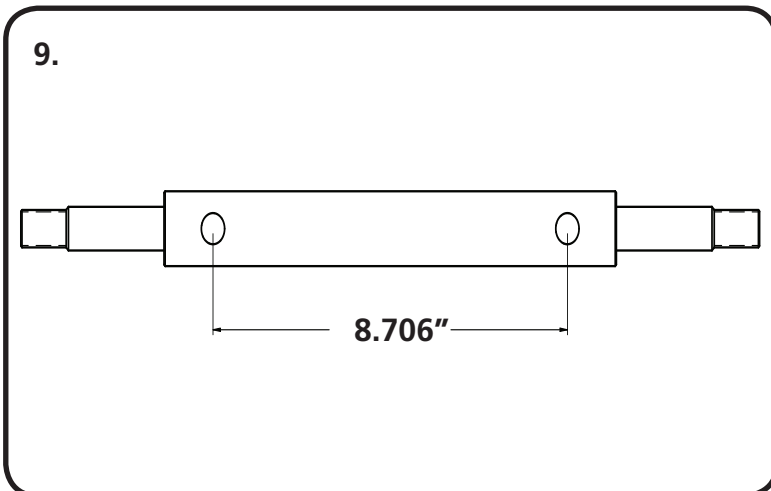

9. The Lower Cross Shaft has 2 different locating Hole patterns. These StrongArms use the 8.706" center to center locating holes. The Pin in the Cross Shaft Saddle that was pointed out in **Image 8**, will locate into these Holes. Use the OEM Hardware to attach the Lower making sure the Locating Pin is in the 8.706" center to center Holes.



10. **Image 10** is an example of the lower bolted to the crossmember. Install 3/4" ID Washer on to each end of the crossshaft against the bushing. Then install the 3/4"-16 lock nut. Snug the nut up against the washer. You want the suspension move freely through its travel.



Installing CoilOver Assembly

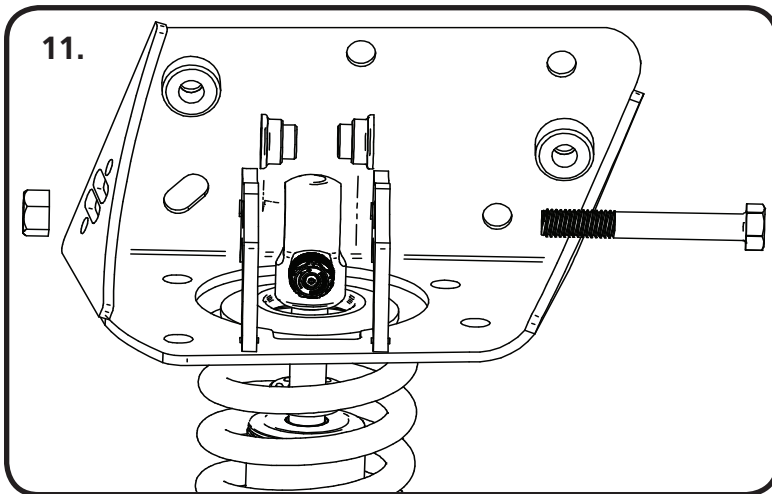

11. Install a spacer on each side of the upper Coilover. Slide the assembly into the upper mount from the bottom side. If your shock has an adjuster knob position it to the wheel side of the mount. Line up the hole in the spacers with the hole in the strap and insert 1/2" x 3 1/4" bolt and install 1/2" Nylok nut.

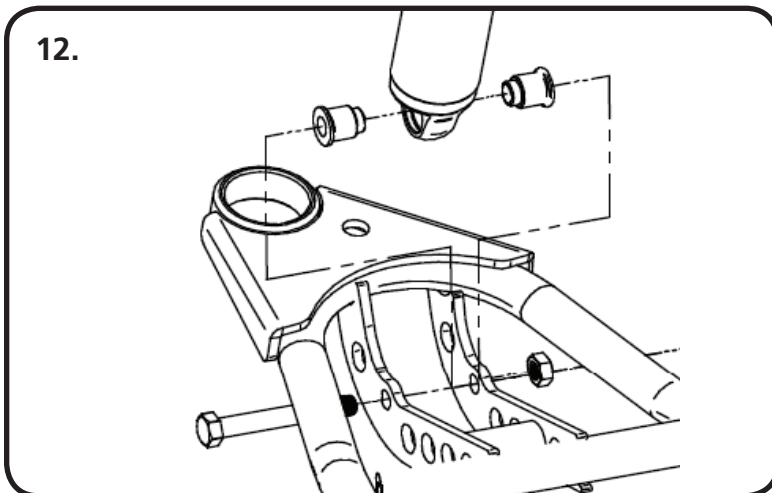

12. Install a spacer on each side of the lower Coilover. Slide the shock with the spacers installed into the lower control arm. Raise the arm up to line up the holes in the bushing with the 1/2" hole in the control arm straps and hold it in place while you install the 1/2" x 3 1/4" bolt and 1/2" Nylok nut. Tighten the upper and lower shock bolts to 75 ftlbs.



13. Depending on your wheel size, you may need an external bumpstop to keep the tire from hitting the inner fender. The bump stop plate attaches to the wheel side of the crossmember. The bent tab goes against the back side of the crossmember with the holes as far out as you can drill them. Use the mount as a template to drill the holes and attach mount with the remaining 3/8 x 1 1/2" bolts washers and Nylok. After mounting the plate, you can attach the bumpstop. Torque the 3/8" hardware to 30 ftlbs.



Installation Instructions



Finishing & Alignment

14. The final step is to reinstall the spindle onto the truck. Slide the balljoint pins into the spindle and install the castle nut on each one. Torque the balljoint nuts and install cotter pins in each one.

Balljoint nut Torque Specs:

Upper: Torque to 50 ft lbs and then tighten nut to align cotter pin hole not exceeding 90ft lbs.

Lower: Torque to 90 ft lbs and then tighten nut to align cotter pin hole not to exceeding 130 ft lbs.

Suggested Alignment Specs:

Camber: Street: -.5 degrees

Caster: Street: +3.0 to + 5.0 degrees

Toe: Street: 1/16" to 1/8" toe in

UPPER CROSSMEMBER TRIMMING TEMPLATE FOR SHOCKWAVE

DRIVER

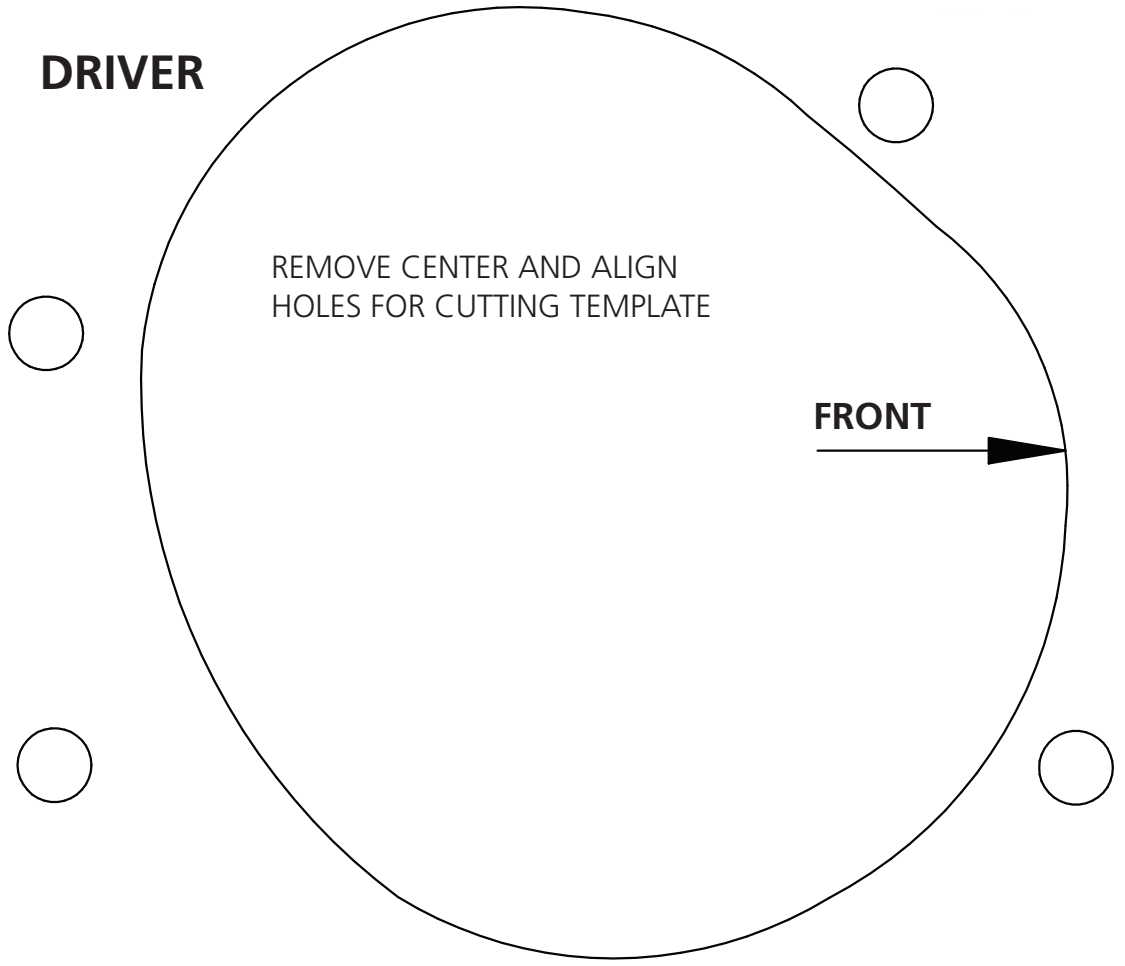

REMOVE CENTER AND ALIGN HOLES FOR CUTTING TEMPLATE

FRONT →

PASSENGER

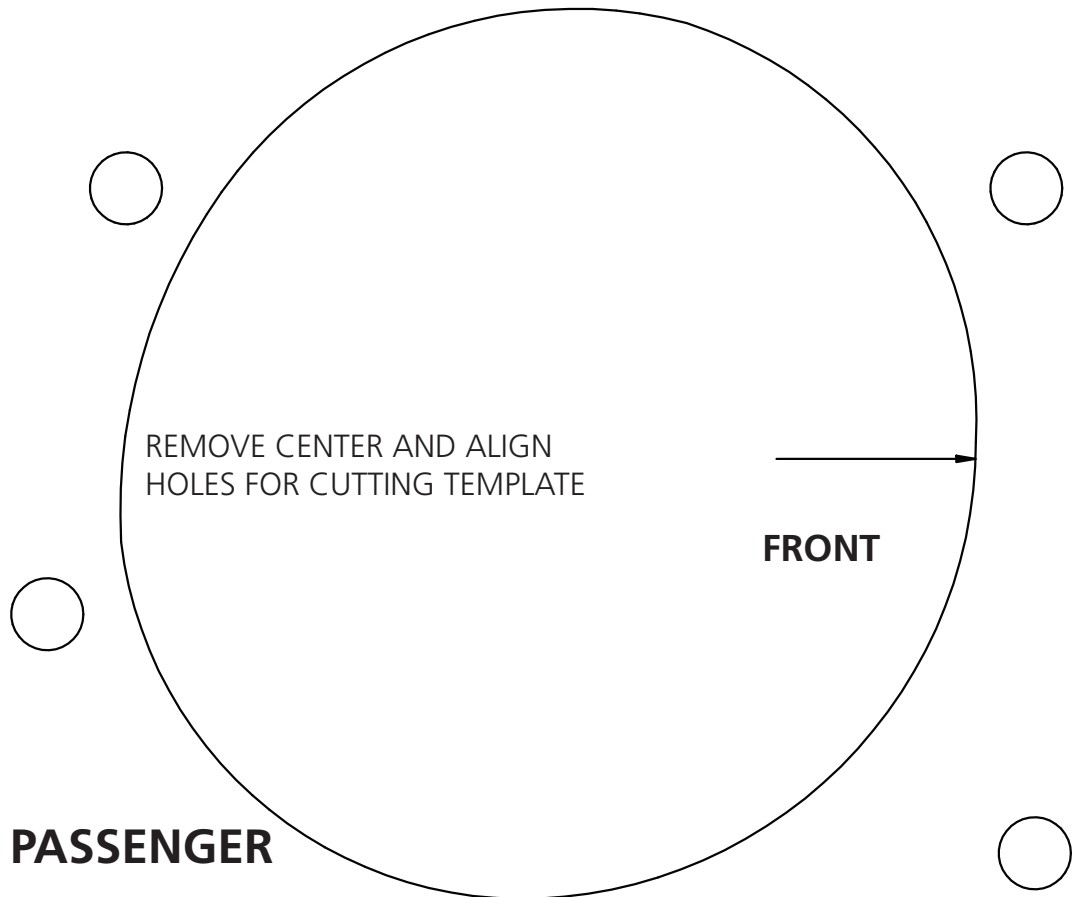



Part # 11363510 - 1973-1987 C10 Front CoilOvers

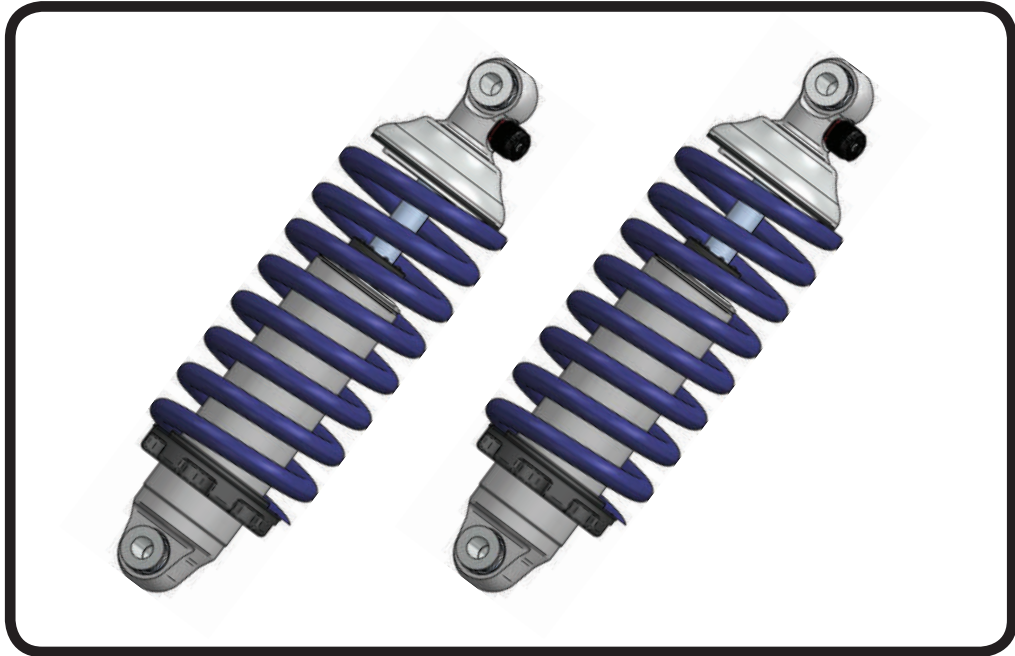

Recommended Tools



**1973-1987 C-10 HQ Series Front Coilovers
Installation Instructions**

Table of contents
Page 16..... Included components



Major ComponentsIn the box

Item #	Part #	Description	QTY
1	24139999	3.6" Stroke HQ Series Shock	2
2	90002024	Shock Eyelet	2
3	90002070	Dropped Coilspring Cap	2
4	59080800	Coilspring 8" 800lb	2
5	70010828	Delrin Spring Washer	4
6	90002222(kit)	Lower Spring Adjuster Nut (90002222 kit)	2
7	90002222(kit)	Adjuster Nut Locking Screw (90002222 kit)	2
8	90002222(kit)	Retaining Ring (90002222 kit)	2
	90001994	5/8" ID Bearing (installed in shock and eyelet)	4
	90001995	Bearing Snap Ring (installed in shock and eyelet)	8

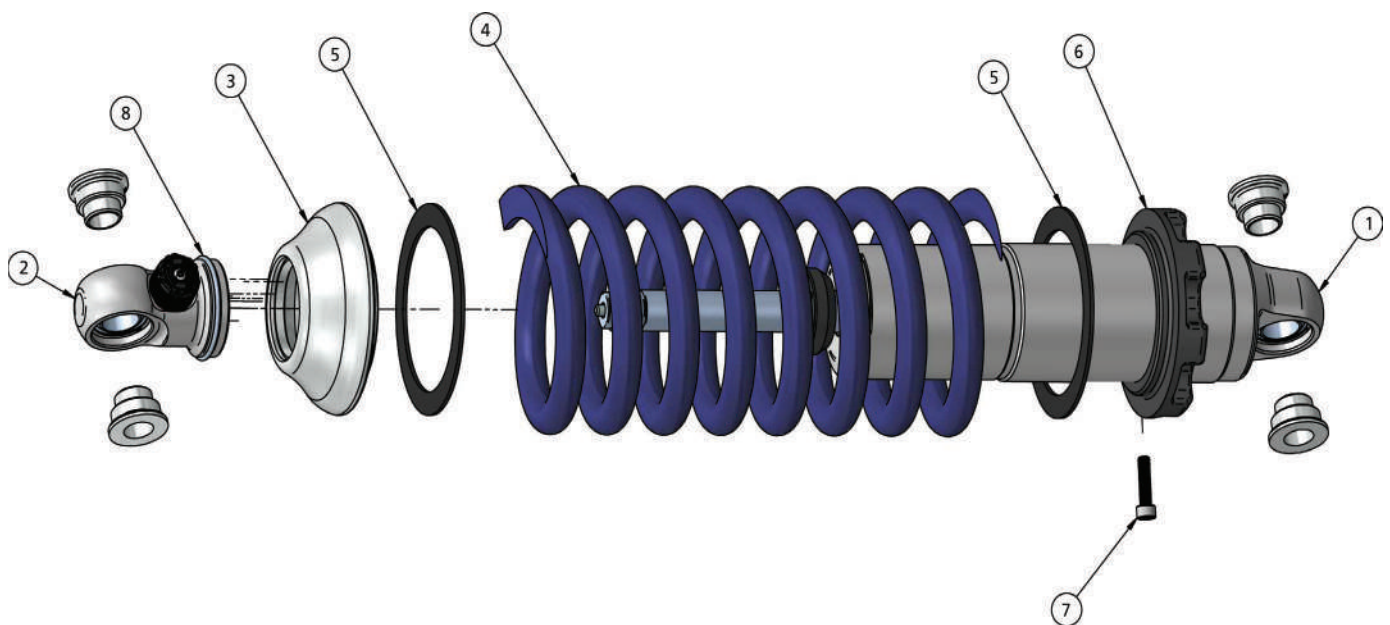



Part # 11362699 - 73-87 C10 Drop Spindles

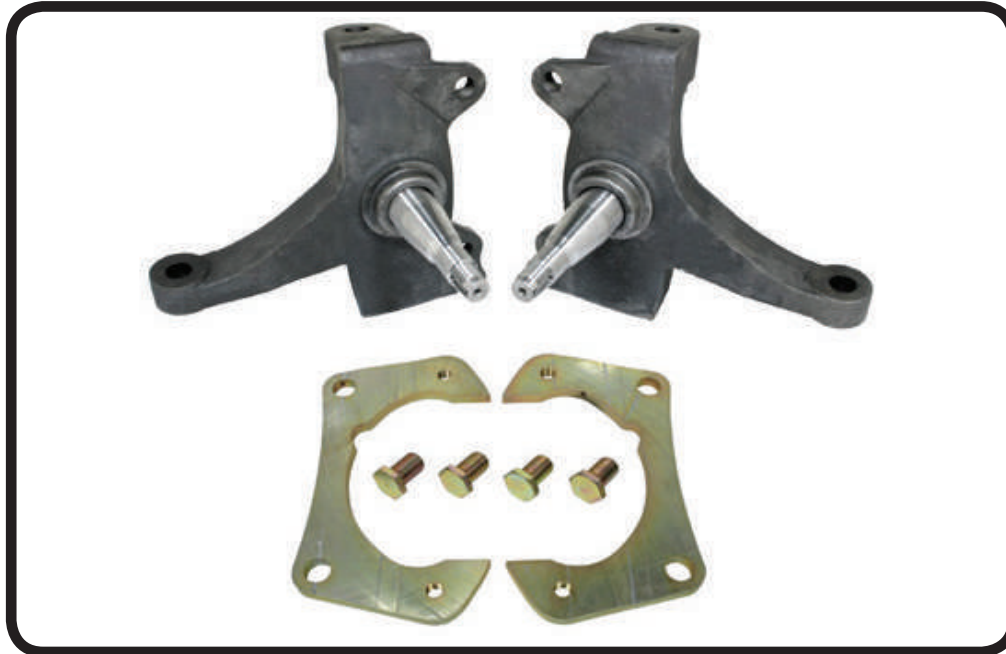

Recommended Tools



Major ComponentsIn the box

1	11369301	Pair of drop spindles
1	90001926	Pair of caliper brackets

Installation

Balljoint nut Torque Specs:

Upper: Torque to 50 ft lbs and then tighten nut to align cotter pin hole not exceeding 90ft lbs.

Lower: Torque to 90 ft lbs and then tighten nut to align cotter pin hole not to exceeding 130 ft lbs.

Note: These spindles are setup for 1973-1987 HD Rotor and Caliper. The HD Rotor is 1 1/4" wide.



**Installation
Instructions**



Part # 11369100 - 1973-1987 C10 Front MuscleBar

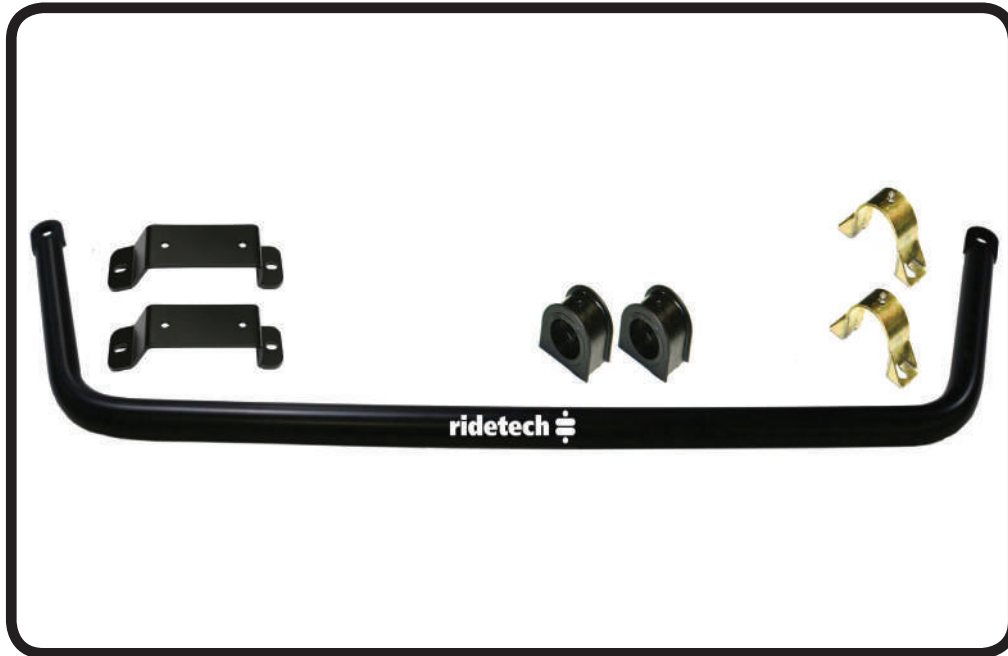

Recommended Tools



**1973-1987 C-10 Front MuscleBar
Installation Instructions**

Table of contents

Page 19..... Included Components and Hardware List

Page 20..... MuscleBar Installation

Page 21..... MuscleBar Installation

THIS MUSCLEBAR IS DESIGNED TO BE USED WITH RIDETECH STRONGARMS.



Major ComponentsIn the box

Part #	Description	QTY
90002768	Front SwayBar	1
	12 mm PosiLink Assemblies (99125001, 90000922, & 90000921)	2
70013130	Delrin Sway Bar Bushing Liner	2
90002513	Bushing Strap	2
70012913	SwayBar Bushing	2
90002591	SwayBar Mounting Bracket	2

HARDWARE KIT #99010050

Part #	Description	Usage	QTY
	SWAY BAR TO FRAME HARDWARE		
99371004	3/8"-16 x 1 1/4" Hex Bolt	Frame & Control Arm Mount	8
99372002	3/8"-16 Nylok Nut	Frame & Control Arm Mount	8
99373003	3/8" SAE Flat Washer	Frame & Control Arm Mount	16
	POSILINK HARDWARE		
99122001	12mm Nylok Nut	PosiLink to Control Arm & MuscleBar	4
99433002	7/16" SAE Flat Washer	PosiLink to Control Arm & MuscleBar	8

Getting Started.....

Install all Front Suspension Components before installing the SwayBar.

If your truck is equipped with an OEM Swaybar, remove it and the Frame Mount to prepare for the MuscleBar installation. The rivets on the frame mount will need to be removed to remove the mount.

This SwayBar kit utilizes a Delrin Liner in the SwayBar Bushing. The Delrin Liner allows the Swaybar to move freely and quietly in the Bushing. The Delrin is self-lubricating, no lubrication is required.



1. Some trucks are equipped with a OEM swaybar. If your truck has one, the OEM mount will need to be removed to install the MuscleBar. This is done by removing the rivets. The rivets can be removed by chiseling the heads off and driving them out or by drilling the rivets out. The new Frame Mount bolts directly in place of the old mount. If your truck doesn't have a sway bar, the mounting holes will still be in the frame.



MuscleBar Installation

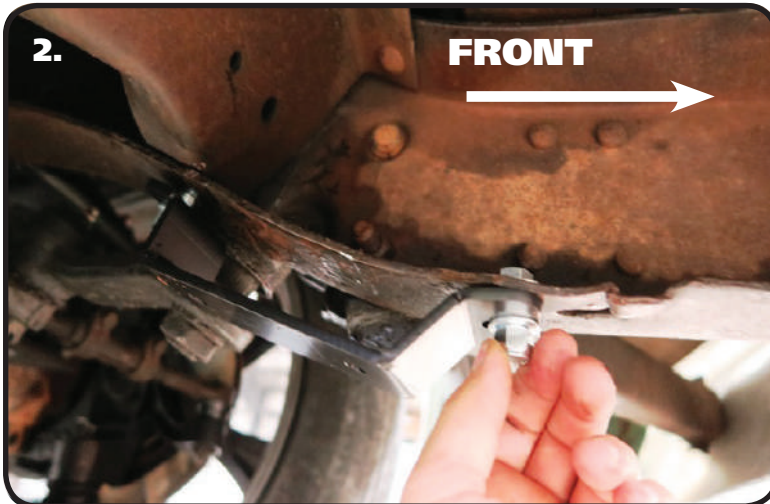

2. The MuscleBar Mount attaches to the frame using the holes from the OEM mount. The end of the frame bracket with the angled bends goes forward. Attach the bracket using a 3/8"-16 x 1 1/4" bolt, 3/8"-16 Nylok nut and a 3/8" Flat Washer on top and bottom. The same hardware setup is used in each hole. Repeat on the other side and tighten hardware.



3. The Delrin Liner is split on one side to ease installation. We found it easier to install by opening up the Liner enough to slide it onto the end of the SwayBar, then sliding it into position. It will open up and slide over the curves in the Bar. Install a Liner on each side of the SwayBar in the approximate location they will need to be when installing the SwayBar on the Truck.

Note: The Delrin is self-lubricating, no lubricant is needed.



4. Open up the Poly SwayBar Bushings and install them over the Delrin Sleeves.



MuscleBar Installation



5. Install Bushing Straps Over the Poly SwayBar Bushings.



6. Hold the SwayBar into position on the truck with the SwayBar arms below the tie rods. Align the holes in the Bushing Straps with the holes in the Frame Brackets. Install a 3/8" Flat Washer on (4) 3/8"-16 x 1 1/4" Hex Bolts and insert them into the holes. Install a 3/8" Flat Washer and 3/8"-16 Nylok Nut on each Bolt. Center the bar in the bushings before snugging up the hardware. Do **NOT** completely tighten the Hardware. It will be left partially loose until the End Links are installed.



7. Attach the PosiLinks to the MuscleBar and StrongArm using a 7/16" SAE Flat washer on each side of the arm on the MuscleBar and each side of the bracket on the StrongArm. The 90 degree PosiLink needs to be installed with the **THREADS POINTING IN TOWARD THE FRAME**. Install 12mm Nylok nut on each posilink and tighten down. Torque to 50 ftlbs.

8. Tighten the bolts attaching the bushings bracket to the frame. After installation, be sure that the Musclebar will go through the entire suspension travel without contacting anything.



Part # 11367199 - 1973-1987 C10 Rear 4Link

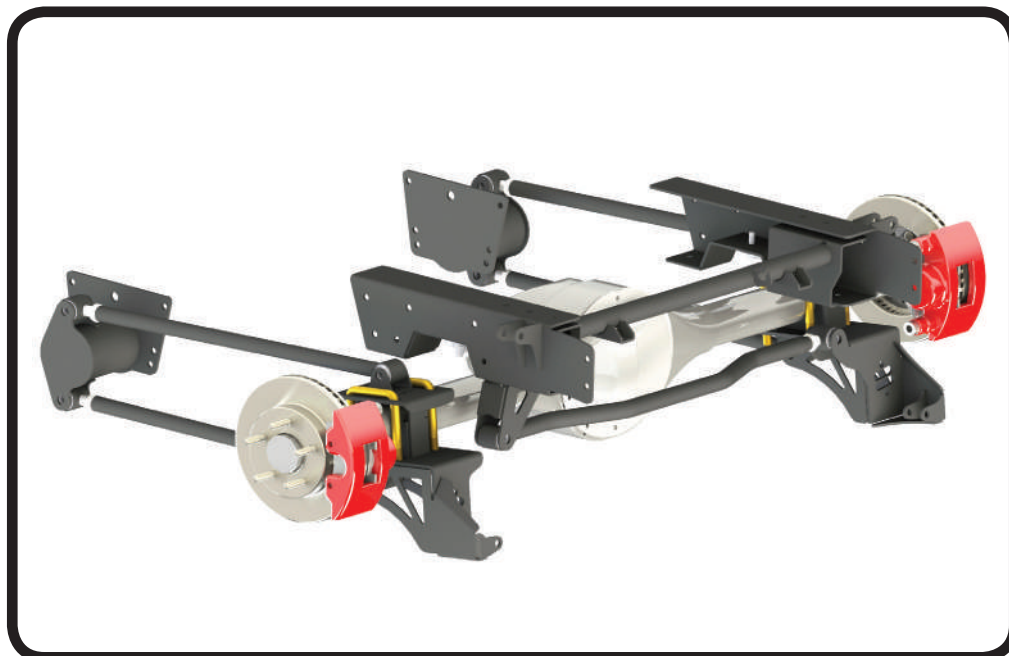

Recommended Tools

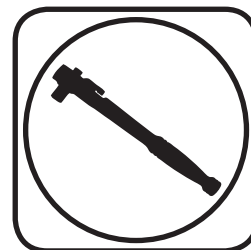
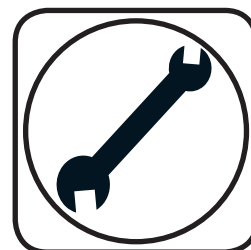

1973-1987 C-10 Rear 4Link Installation Instructions

Table of contents

Page 23-24....	Included Components
Page 25.....	Hardware List & Getting Started
Page 26.....	Disassembly
Page 27.....	"C" Notch Installation
Page 28.....	Upper Cross Member Installation
Page 29.....	Frame Mount & Axle Mount Installation
Page 30.....	Installing Lower Axle Mount & 4Link bars
Page 30.....	Installing Panhard bar and Shockwave/CoilOvers
Page 31.....	Finishing



Major ComponentsIn the box

Item #	Part #	Description	QTY
1	90000668	Upper Crossmember	1
2	90000670	Driver C-Notch	1
3	90000671	Passenger C-Notch	1
4	90002746	Driver Lower Axle Bracket	1
5	90002748	Passenger Lower Axle Bracket	1
6	90000952	Panhard Bar - Set to 33 1/2"	1
7	90000673	Upper Axle Bracket	2
8	90000666	4Link Frame Mount - Driver	1
9	90000667	4Link Frame Mount - Passenger	1
10	90002824	4Link Bars - Set to 26 1/2"	4
11	70013364	R-Joint Rod End	5
	70013334	R-Joint Spacer (Not Shown)	18
	90001942	Rubber Bushings - Pressed into Panhard Bar Frame End	1
	70013495	U-Bolt - 5/8-18 x 3.13 x 5.5 (Not Shown)	4
	90002043	Shockwave/Coilover Spacers (Not Shown)	8
	99752004	3/4"-16 Jam Nut - Installed on Bars	5
	70013322	Short Bumpstops with Hardware	2
R-Joint Components - (Installed in bar ends)			
	70013279	Retaining Ring	9
	70013280	Wavo Wave Spring	9
	70013275	R-Joint Center Ball	9
	70013276	R-Joint Composite Center Ball Cage	9



Major ComponentsIn the box

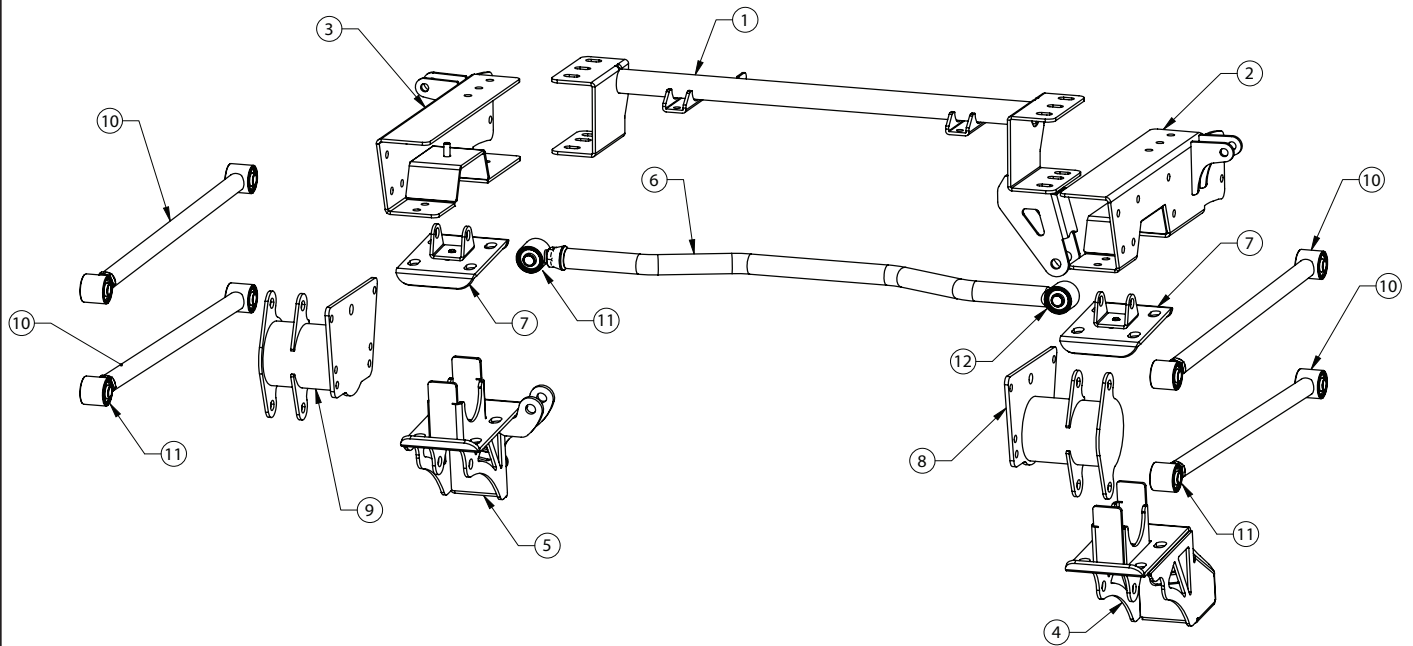

R-JOINT SPACER INSTALLATION

Install the Spacers by inserting the SMALL side of the SPACER into the Center Pivot Ball. Push them in until they bottom out and stop.

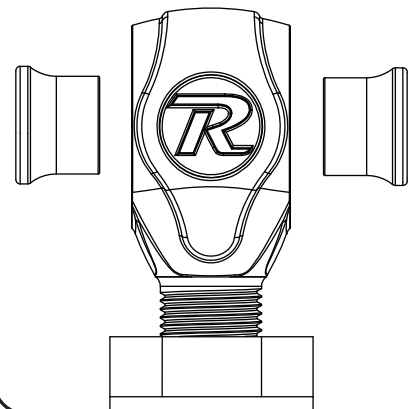



Hardware ListIn the box (Kit# 99010014)

The Hardware Kit contains bags to help aid in selecting the correct hardware for the component being installed. The hardware list shows how the hardware is bagged.

QTY	Part Number	Description	USAGE
4LINK BARS & PANHARD BAR			
10	99621003	5/8" x 2 3/4" SAE Gr. 8 Bolt	4Link Bars & Panhard Bar
10	99622006	5/8" SAE Nylok Jam Nut	4Link Bars & Panhard Bar
20	99623001	5/8" SAE Flat Washer	4Link Bars & Panhard Bar
FRONT 4LINK BAR MOUNT			
12	99431002	7/16" x 1 1/4" USS Bolt	Front 4Link Bar Mount to Frame
24	99433002	7/16" SAE Flat Washer	Front 4Link Bar Mount to Frame
12	99432001	7/16" USS Nylok Nut	Front 4Link Bar Mount to Frame
AXLE BRACKET TO AXLE			
8	99621009	5/8" x 6" SAE Gr. 8 Bolt	Axle Bracket to Axle
8	99622001	5/8" SAE Nylok Nut	Axle Bracket to Axle
16	99623001	5/8" SAE Flat Washer	Axle Bracket to Axle
"C" NOTCH MOUNTING - SIDE & FRONT LOWER			
24	99431002	7/16" x 1 1/4" USS Bolt	"C" Notch to Frame - Side & Front Lower
24	99432001	7/16" USS Nylok Nut	"C" Notch to Frame - Side & Front Lower
48	99433002	7/16" SAE Flat Washer	"C" Notch to Frame - Side & Front Lower
"C" NOTCH MOUNTING - REAR TOP & BOTTOM			
12	99431008	7/16" x 1 1/2" USS Bolt	"C" Notch to Frame - Rear Top & Bottom
12	99432001	7/16" USS Nylok Nut	"C" Notch to Frame - Rear Top & Bottom
24	99433002	7/16" SAE Flat Washer	"C" Notch to Frame - Rear Top & Bottom
BRAKE LINE BRACKET			
1	99311002	5/16" x 1 1/4" USS Bolt	Brake Line Bracket
1	99312003	5/16" USS Nylok Nut	Brake Line Bracket
2	99313002	5/16" SAE Flat Washer	Brake Line Bracket
SHOCK MOUNTING			
4	99501050	1/2" x 2 1/2" USS Bolt Gr. 8	Shocks to Mounts
4	99502009	1/2" USS Nylok Nut Gr. 8	Shocks to Mounts
8	99503012	1/2" SAE Flat Washer Gr. 8	Shocks to Mounts



Disassembly

Congratulations on your purchase of the Ridetech Rear 4Link System. This system has been designed to give your truck excellent handling along with a lifetime of enjoyment. Some of the key features of this system: C-notches to give your suspension the travel it needs at the lowered height, 4Link setup to replace the leaf spring, this provides better control of the rear axle, long panhard bar to reduce the side-to-side movement of the differential, and the biggest feature of all, it allows the use of Shockwaves or CoilOvers.

Note: This system is designed for use with the Ridetech Shockwaves or CoilOvers and the MuscleBar swaybar. **The factory shocks and springs or the factory sway bar will not fit this 4Link.**

1. Raise the vehicle to a safe and comfortable working height and support it by the frame. You will need to be able to move the rear differential up and down. Let the rear suspension hang freely.

2. Remove the bed.

3. Raise the axle a couple inches and support it so that it cannot rotate. Remove the leaf springs and shock absorbers. Refer to the factory service manual for proper disassembly procedures.



4. The Brake Line Bracket will need to be removed from the passenger side frame rail. This will require separating the steel line from the rubber line at the bracket. There is a provision for the brake line in the upper bridge of the 4 link kit. Cap the line off to help prevent the brake fluid from draining out of the line. Remove the bracket by removing the rivets. We like to use a die grinder to cut a "+" in the head of the rivet. We then knock the head off with a hammer and chisel or an air chisel. With the head removed, knock the rivet out of the bracket and frame.

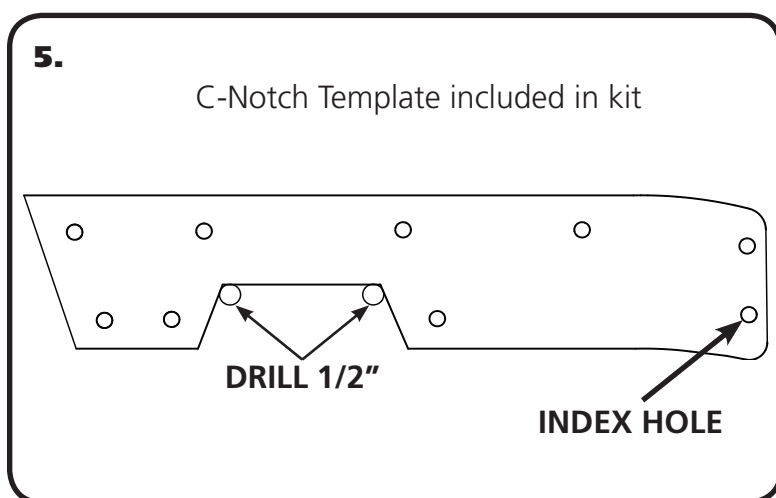

5. To allow maximum drop on this truck the frame must be notched. The template for the notch will locate off of the index hole shown below. Use the supplied "C" Notch template to mark out the frame for cutting. Before cutting out the frame, support the frame in front of and behind the "C" Notch area. We suggest doing one side at a time. The "C" Notch template has an arrow pointing to the front of the truck. Use the "Index Hole" in the back side of the template to help locate the Template.



"C" Notch Installation

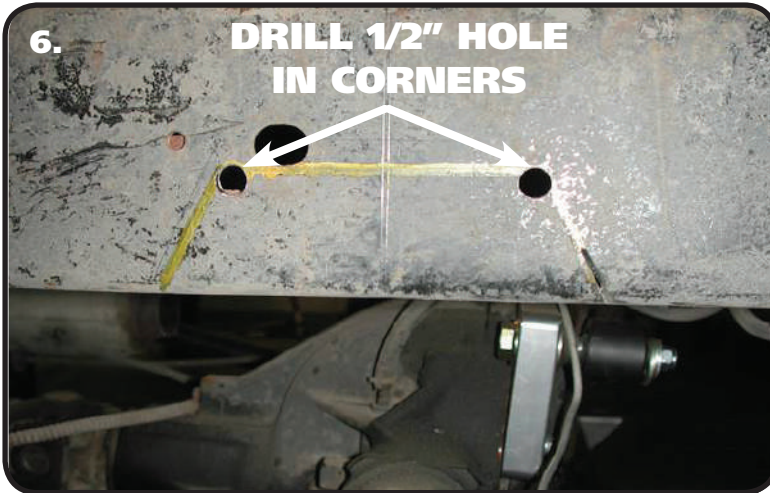

6. Use the supplied Template to mark the cut lines on the frame, then drill out the two corners with a 1/2" drill bit. This will give the cut a round edge and eliminate the possibility for stress fractures. Then cut the notch with a saw-z-all, cutoff wheel or plasma cutter. Grind all edges smooth.

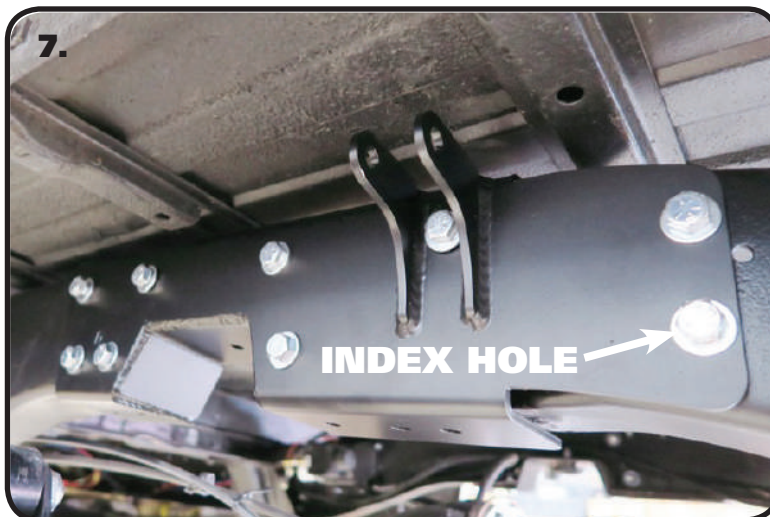

7. Slide the C-Notch in place making sure the "Index Hole" is aligned. If it doesn't align, you may need to trim the C-Notch opening you cut in the frame. Once you have the C-Notch fitting properly, use it for a template to drill the attaching holes in the frame. Drill the holes in the side of the frame and also the top and bottom of the frame. Use a 7/16" drill bit to drill these. You will have to drill out the "Index Hole" to 7/16" too. Install a 7/16" Flat Washer onto (12) 7/16"-14 x 1 1/4" bolts. Insert the bolts/washers into the drilled holes leaving the bolts out of the rear 3 holes on the top and bottom of the C-Notch. Install a 7/16" Washer and 7/16" Nylok Nut on each of the bolts sticking through the frame and tighten to 50 ftlbs. Repeat steps 5-7 on other side.



8. Install the bumpstops into the "C" Notches using a 3/8" nut and flat washer. Tighten the hardware enough to hold the bumpstop in place.



Upper Cross Member Installation

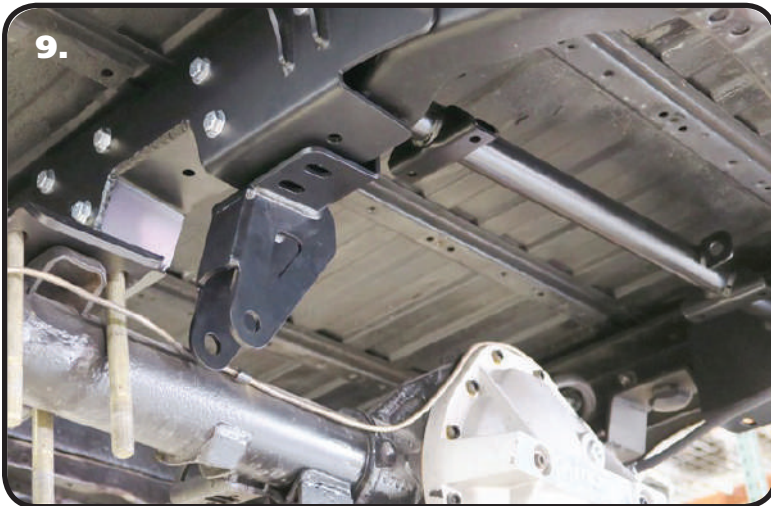

9. After both C-Notches have been installed, the Upper Cross Member can be installed. The Cross Member is located using the rear 3 holes in the top and bottom of each C-Notch. The Panhard bar mount is located on the driver's side of the Cross Member. The Cross Member attaches underneath the Frame on the top, and underneath the C-Notch on the bottom. Install a 7/16" Flat Washer on (12) 7/16" x 1 1/2" Hex Bolts and insert them into each of the (12) holes. Install all of the bolts with the Nylok Nuts inside the frame. Install a 7/16" Flat Washer & 7/16" Nylok Nut on each of the (12) Bolts and tighten to 50 ftlbs.



10. Attach the rubber brake line to the Upper Cross Member using the OEM clip. You may have to tweak the steel brake line to reposition it to thread into the rubber brake line. Thread the steel brake line into the rubber brake line and tighten.

YOU WILL NEED TO BLEED THE REAR BRAKES BEFORE DRIVING THE TRUCK!!



11. The OEM front leaf spring mounts will need to be removed from the frame rail. This can be done by either drilling the rivets out or removing the rivet heads and driving them out. We remove the rivet heads by cutting a " + " in the head with a die grinder then we cut the head off with a hammer and chisel or with an air chisel. Once the head is removed, the rivet can be driven out with a hammer and punch. After removing the frame mounts, drill the rivet holes with a 7/16" drill bit.



Frame Mount & Axle Mount Installation

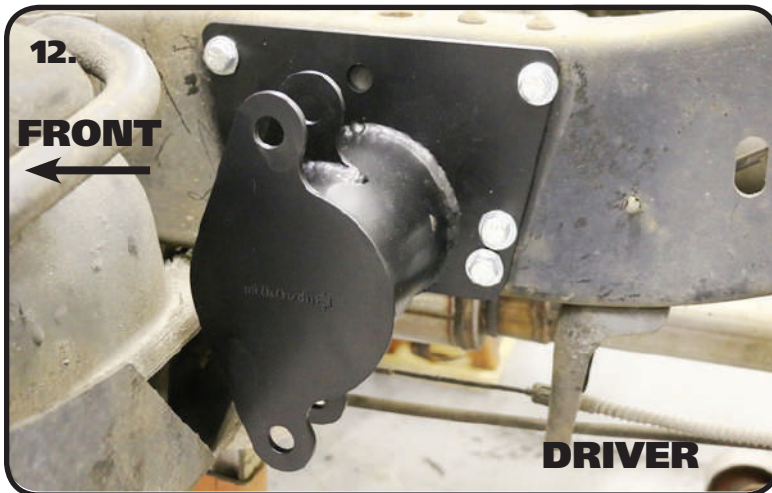

12. The Bar Mounts bolt in place of the OEM front leaf spring mount. There is a Driver and Passenger Mount. **Image 12** shows the Driver Mount. The Tabs are to the FRONT of tube. Install a 7/16" Flat Washer on (6) 7/16" x 1 1/4" Bolts. Hold the Mount in place and insert the bolts/washer through the mount and frame. Install a 7/16" Flat Washer and 7/16" Nylok Nut on each bolt sticking through the frame and tighten to 50 ftlbs. Repeat on the other side.

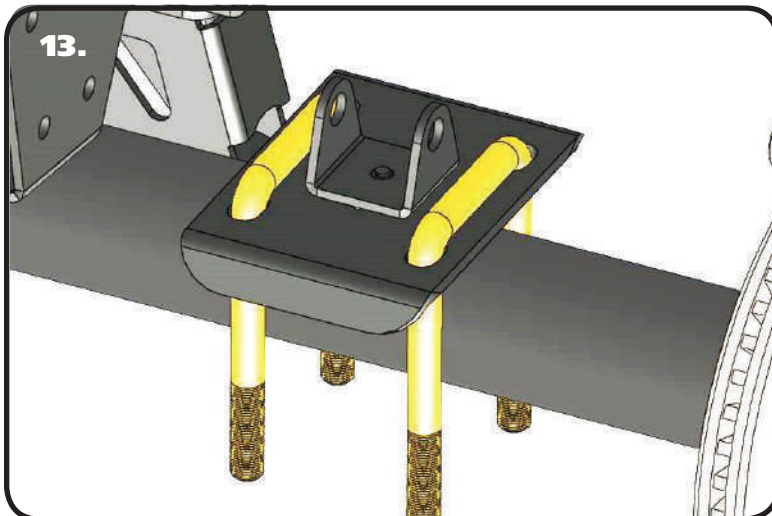

13. The Kit includes 2 Upper Bar Mounts that are the same. Each one sits on a leaf spring pad with the center pin indexed into the center hole of the leaf spring pad. Sit an Upper Bar Mount on top of the axle with the locating pin into the center hole of the leaf spring pad. Install a 5/8" Square U-bolts through each pair of side holes in the Upper Bar Mount with the threads pointing down. The U-bolts will run parallel to the frame.

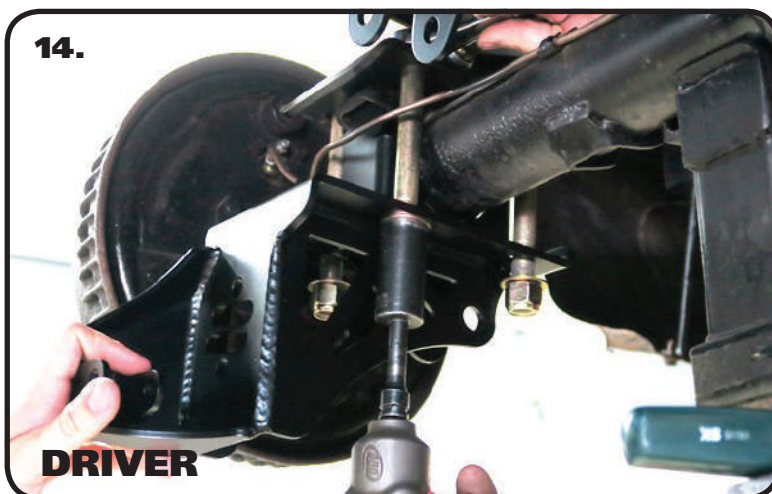

14. The Kit includes a Driver and Passenger Lower Axle Mount; the two are different. The Passenger Mount has the Panhard bar mount built into it. Image 13 shows the Driver Mount. Hold the Mount up in place against the bottom of the axle tube. The tabs will nest against the bottom of the leaf spring pad. Make sure the u-bolts drop through the holes in the Lower Mount. Install a 5/8" Flat Washer followed by a 5/8" Nylok Nut on each leg of the U-Bolts. Tighten the Nuts evenly until the Lower Mount is tight against the tube and leaf spring pad. Then torque the Nuts to 60 ftlbs in a crisscross fashion.



Installing Lower Axle Mount & 4Link Bars

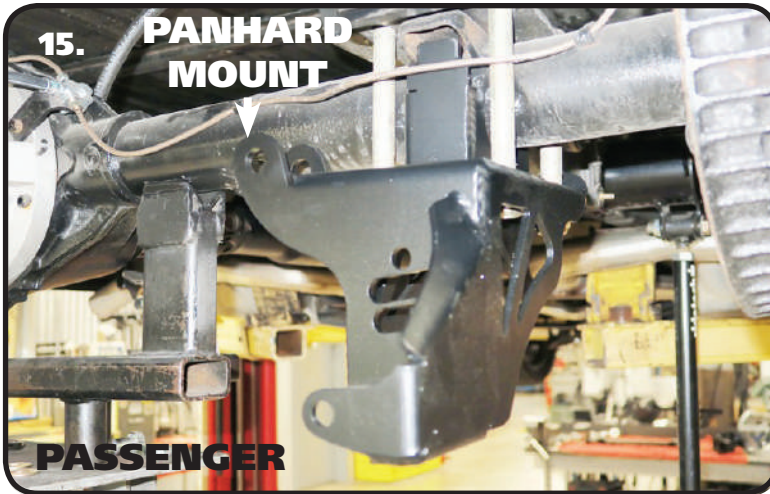

15. Repeat the above step on the Passenger Lower Mount. Torque the hardware to 60 ftlbs in a crisscross fashion.

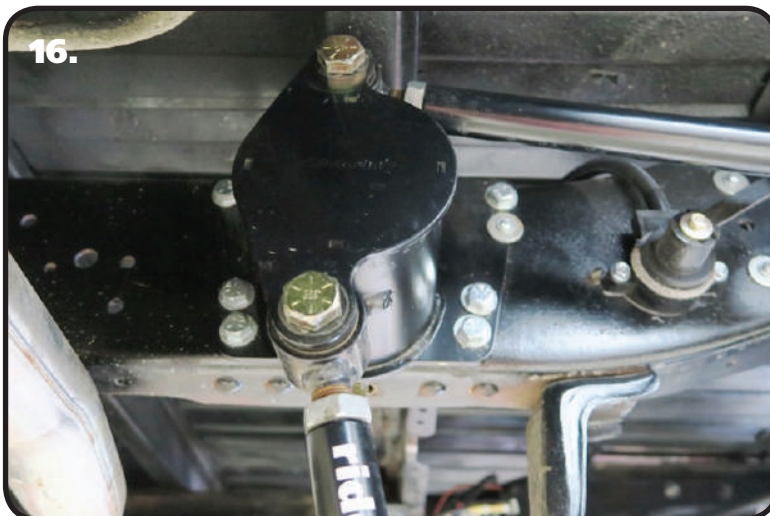

16. This Kit contains (4) 4Link bars that are the same. **Insert the R-Joint Spacers into the Center Pivot Ball of the R-Joints in the bars as shown on Page 3.** Each Bar is attached with a 5/8" x 3" Bolt, 5/8" Nylok Jam Nut, & (2) 5/8" Flat Washers. Install a 5/8" Flat Washer on each of the 5/8" x 3" Bolts. Attach the front of the bars to the frame mounts first. Do this by holding the Bar in position and insert the 5/8" Bolt/Washer through the Mount and Bar End. Install a 5/8" Flat Washer followed by a 5/8" Nylok Jam Nut on the threads of the bolt. Install all of the Bars before tightening the Hardware.



17. Attach the rear of the Bars to the Axle Mounts. The upper bar gets installed in the Upper Axle Bracket, the lower bar gets installed in the Lower Axle Bracket. Each Bar is attached using (1) 5/8" X 3" Bolt, (2) 5/8" Flat Washer & (1) 5/8" Nylok Jam Nut. Install a 5/8" Washer on each Bolt before inserting them through the Bar/Bracket. Install a 2nd 5/8" Flat Washer on the threads of the bolt that are sticking out of the bracket followed by a 5/8" Nylok Nut. Tighten the hardware enough to eliminate any gaps.



Installing Panhard Bar and Shockwaves/Coilovers



18.

18. Install the Panhard bar into the frame bracket. The Panhard Bar is a bent bar, it is bent to clear the center section of the rear differential. The bar needs to be mounted with the BEND to the REAR and the Rubber Bushing in the Frame Mount, this will help it clear the differential cover. The Panhard bar is attached using (1) 5/8" x 3" bolt, (1) 5/8" Nylok Jam Nut & (2) 5/8" Flat Washers. Tighten the hardware enough to eliminate any gaps.

Note: The panhard bar is set at 33 1/2" before it is shipped, but may need adjusted to center the axle at ride height.



19.

19. Install the R-Joint Spacers into the Center Pivot Ball of the R-Joint in the Panhard Bar. Install the other end of the Panhard bar into the mount on the Passenger Lower Axle Mount. The Panhard bar is attached using (1) 5/8" x 3" bolt, (1) 5/8" Nylok Jam Nut & (2) 5/8" Flat Washers. Tighten the hardware enough to eliminate any gaps.



20.

SPACER

20. Insert a Spacer into each side of the upper Shockwave/CoilOver bearing. Slide the assembly into the upper shock mount. If your shock has an adjuster knob, position it so that the knob points toward the outside of the truck. Line up the hole in the spacers with the hole in the upper shock mount and insert 1/2" x 2 1/2" bolt and 1/2" Nylok nut with a 1/2" SAE Flat Washer on each side of the mount.

Note: If installing Shockwaves and you want to locate the air fitting in a different location, the air spring assembly can be rotated on the shock by grabbing the shock and air spring assembly by hand and spinning the shock in the air spring assembly.



Finishing

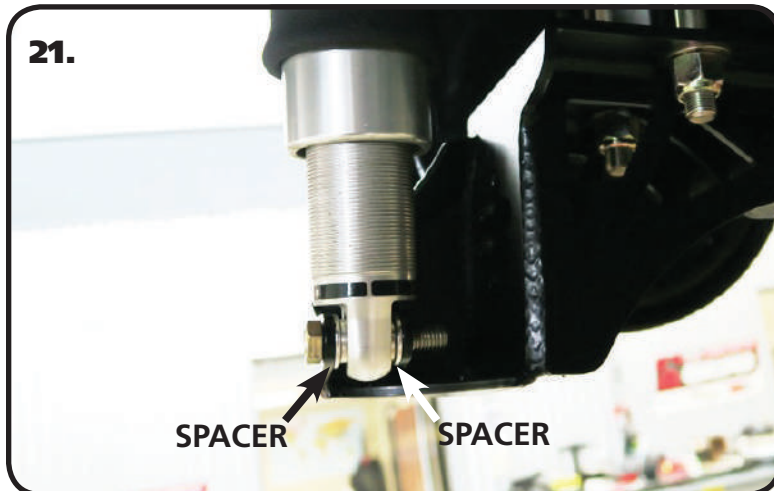

21. Insert a Spacer into each side of the lower Shockwave/CoilOver bearing. Slide the shock, with the spacers installed, into the mount on the Lower Axle Mount. You may need to jack the rearend up to line up the holes in the bushings with the 1/2" hole in the shock mounts and hold it in place while you install the 1/2" x 2 1/2" Bolt and 1/2" Nylok Nut with a 1/2" SAE Flat Washer on each side of the mount. Tighten the upper and lower shock bolts to 75 ftlbs.

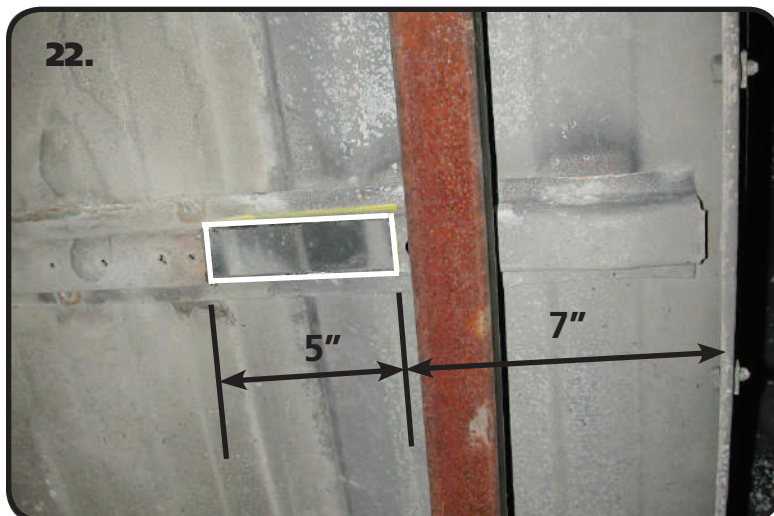

22. To allow clearance for the C-Notch, a section of the bed floor brace that is above the axle must be removed. This section is approximately 5" wide and about 7" from the fender well.

23. Tighten all fasteners. If you are going to install the Ridetech MuscleBar, now is a good time to do it. Reinstall the bed and set the truck back on the ground.

24. Set ride height on the truck. The ride height of the Shockwave/CoilOver is approximately 14 1/2". If you are using Shockwaves, this is done by changing the air pressure in the Shockwaves. If you are using CoilOvers, the ride height is done by using the adjuster nut for the coil spring. The coil spring on the CoilOver will have some preload in the spring to get ride height, this is normal.

25. Measure to make sure the axle is centered at ride height. We prefer to measure between the frame and wheel. Make sure you are measuring the truck in the same location on both sides. If the measurements are off more than 1/16", adjust the Panhard Bar to center the differential.

BLEED THE REAR BRAKES!!!



Part # 11366510 - 1973-1987 C10 Rear CoilOvers

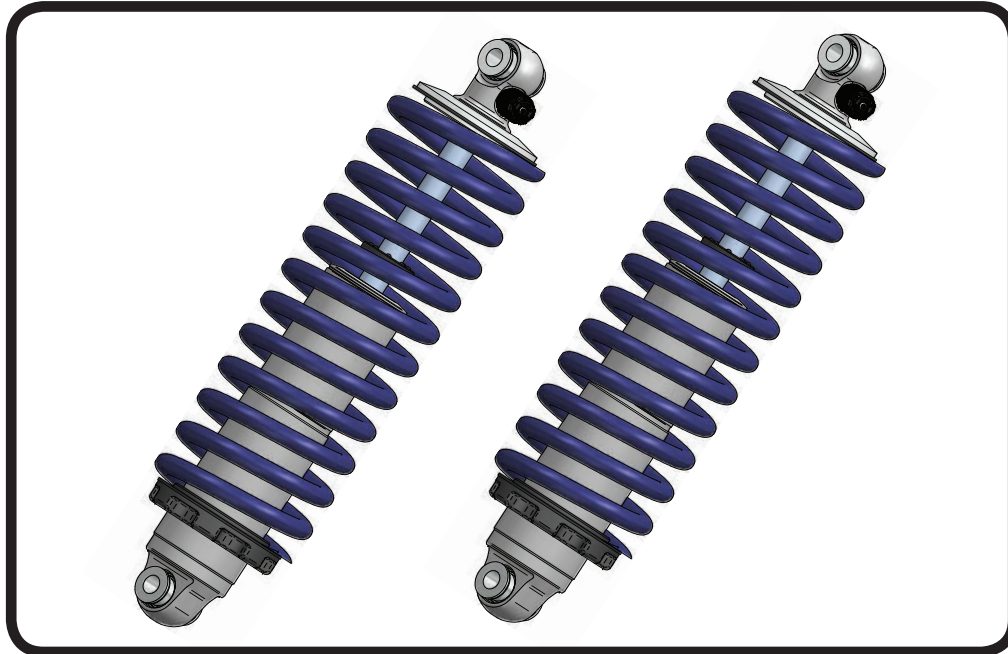

Recommended Tools

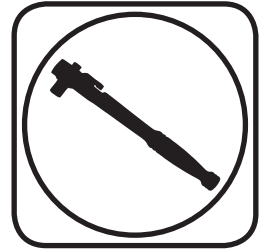

1973-1987 C-10 HQ Series Rear Coilovers Installation Instructions

Table of contents

Page 33..... Included components

Page 34..... Assembly and Adjusting

Page 35..... Shock Adjustment and Setting Height



Major ComponentsIn the box

Item #	Part #	Description	QTY
1	24159999	5.2" Stroke HQ Series Shock	2
2	90002024	Shock Eyelet	2
4	59120225	Coilspring 12" 225lb	2
5	70010828	Delrin Spring Washer	4
6	90002222(kit)	Lower Spring Adjuster Nut (90002222 kit)	2
7	90002222(kit)	Adjuster Nut Locking Screw (90002222 kit)	2
8	90002222(kit)	Retaining Ring (90002222 kit)	2
	90001994	5/8" ID Bearing (installed in shock and eyelet)	4
	90001995	Bearing Snap Ring (installed in shock and eyelet)	8

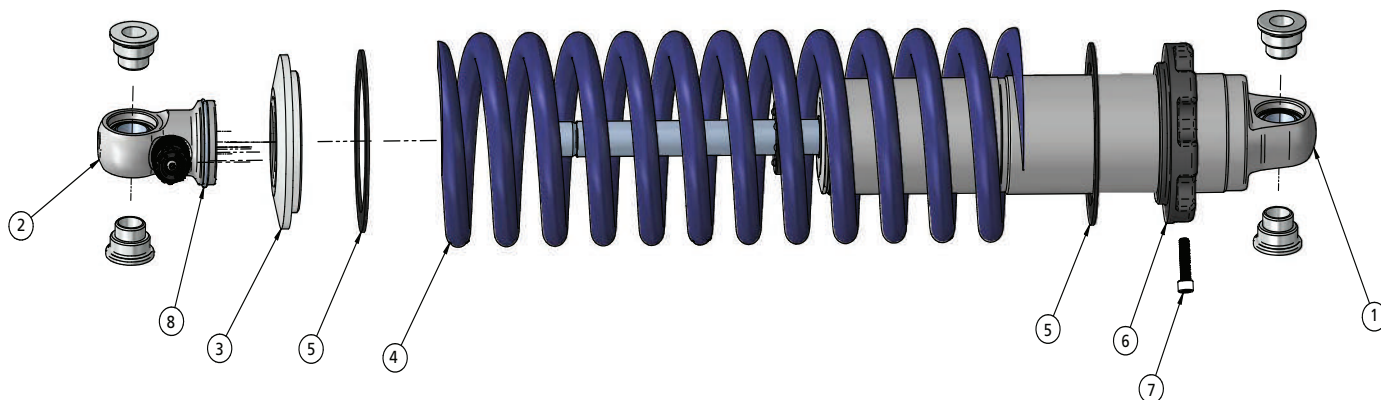



Assembly and Adjusting



1 First using the supplied lower adjuster nut(90002222) thread the nut onto the shock from the bottom side as seen in figure 1

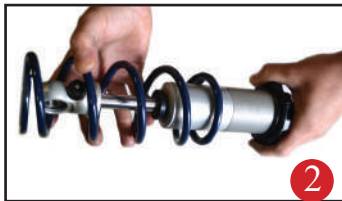

2 Next install delrin washers then coil spring over the top of the shock as seen in figure 2



3 Before the upper spring mount can be installed screw the adjuster knob on the upper eye mount to the firmest setting (clockwise) as seen in figure 3.



4 Slide the Delrin washer over the spring, Next slide the upper spring mount (90002222) over eyelet as seen in figure 4.



5 Install upper spring mount retainer clip (90002057) into the groove on the upper eyelet as seen in figure 5. Then reinstall adjuster to complete assembly.



The included set of bearing spacers (900002044) are used to adapt the coil-overs to just about any application. The supplied spacers allow the coil-overs to accept 5/8" or 1/2" bolts.

Shock adjustment 101- Single Adjustable

Rebound Adjustment:

How to adjust your new shocks.

The rebound adjustment knob is located on the top of the shock absorber protruding from the eyelet.

You must first begin at the ZERO setting, then set the shock to a soft setting of 20.



-Begin with the shocks adjusted to the ZERO rebound position (full stiff). Do this by rotating the rebound adjuster knob clockwise until it stops.



-Now turn the rebound adjuster knob counter clock wise 20 clicks. This sets the shock at 20. (settings 21-24 are typically too soft for street use).

Take the vehicle for a test drive.



-if you are satisfied with the ride quality, do not do anything, you are set!

-if the ride quality is too soft increase the damping effect by rotating the rebound knob clock wise 3 clicks. **CONTINUE ON NEXT PAGE.**



Shock Adjustment

Take the vehicle for another test drive.



-if the vehicle is too soft increase the damping effect by rotating the rebound knob clock wise 3 additional clicks.

-If the vehicle is too stiff rotate the rebound adjustment knob counter clock wise 2 clicks and you are set!

Take the vehicle for another test drive and repeat the above steps until the ride quality is satisfactory.

Note:

One end of the vehicle will likely reach the desired setting before the other end. If this happens stop adjusting the satisfied end and keep adjusting the unsatisfied end until the overall ride quality is satisfactory.

Final Tightening and Adjusting

Ride Height

We have designed most cars to have a ride height of about 2" lower than factory. To achieve the best ride quality & handling, the shock absorber needs to be at 40-60% overall travel when the car is at ride height. This will ensure that the shock will not bottom out or top out over even the largest bumps. Measuring the shock can be difficult, especially on some front suspensions. Measuring overall wheel travel is just as effective and can be much easier. Most cars will have 4-6" of overall wheel travel. One easy way to determine where you are at in wheel travel is to take a measurement from the fender lip (center of the wheel) to the ground. Then lift the car by the frame until the wheel is just touching the ground, re-measure. This will indicate how far you are from full extension of the shock. A minimum of 1.5" of extension travel (at the wheel) is needed to ensure that the shock does not top out. If you are more than 3" from full extension of the shock then you are in danger of bottoming out the shock absorber.

Adjusting Spring Height

When assembling the CoilOver, screw the spring retainer tight up to the spring (0 preload). After entire weight of car is on the wheels, jounce the suspension and roll the car forward and backward to alleviate suspension bind.

- If the car is too high w/ 0 preload then a smaller rate spring is required. Although threading the spring retainer down would lower the car, this could allow the spring to fall out of its seat when lifting the car by the frame.
- If the car is too low w/ 0 preload, then preload can then be added by threading the spring retainer up to achieve ride height. On 2.6" - 4" stroke shocks, up to 1.5" of preload is acceptable. On 5-7" stroke shocks, up to 2.5" of preload is acceptable. If more preload is needed to achieve ride height a stiffer spring rate is required. Too much preload may lead to coil bind, causing ride quality to suffer.