



**Part # 11300201**  
**67-70 Impala Coil-Over System**  
HQ Series

**Front Components:**

1	11283509	Front HQ Series Shockwaves
1	11282899	Front Lower StrongArms
1	11283699	Front Upper StrongArms
1	11289100	Front MuscleBar

**Rear Components:**

1	11280709	Rear HQ Series Shocks
1	11284499	Rear Lower StrongArms
1	11306699	Rear Upper StrongArm & Panhard Bar Kit
1	11284799	Rear Coilspring Kit for Rear StrongArms
1	11289102	Rear MuscleBar

**Components:**

1	85000000	Spanner Wrench
---	----------	----------------



**Part # 11283510**  
**65-70 Impala HQ Series Front CoilOvers**  
For Use w/ StrongArms

**Shock Assembly:**

2	24139999	3.6" stroke HQ Series shock
2	90009989	2.75" rebound adjustable threaded stud top
2	90001994	.625" I.D. bearing
4	90001995	Bearing snap ring

**Components:**

2	59080750	Coil spring – 8" long / 750 # rate
2	90002313	2.75" stud top base
2	90002222	Spring retainer kit
2	90002070	¾" Dropped upper mount
2	90001902	Aluminum cap for Delrin ball
2	90001903	Delrin ball upper half
2	90001904	Delrin ball lower half
4	70010828	Delrin Spring Washer

**Hardware:**

2	99562003	9/16" SAE Nylok jam nut	Stud top hardware
---	----------	-------------------------	-------------------

# COILOver

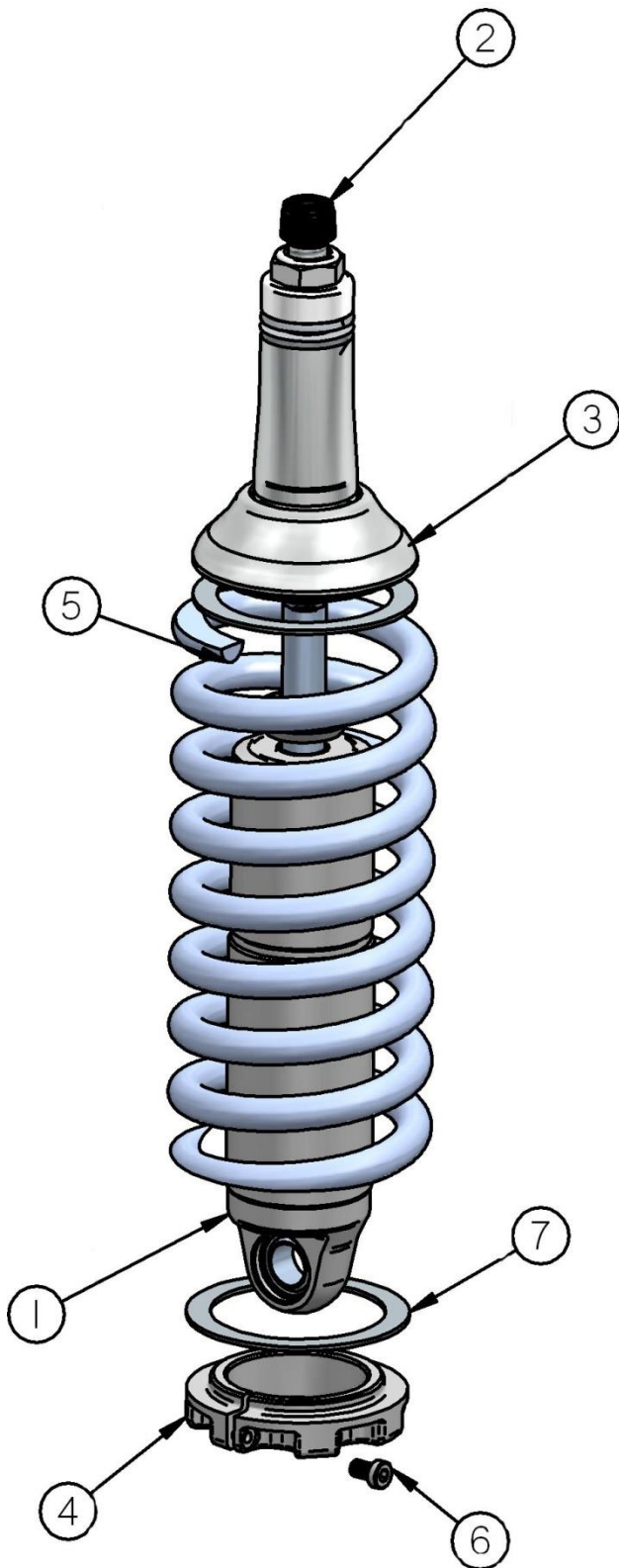

1. Impact Forged, Monotube shock
2. Rebound adjustment knob (SA Only)
3. Upper coil spring retainer  $\frac{3}{4}$ "  
dropped cap.
4. Lower coil spring retainer
5. High tensile coil spring
6. Set screw
7. Delrin Washer

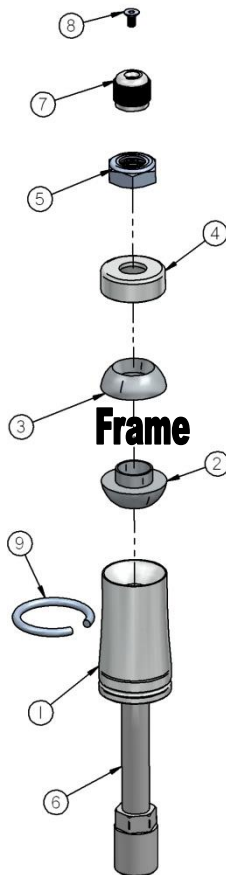

1. Stud top base
2. Lower Delrin ball half
3. Upper Delrin ball half
4. Aluminum cap
5. 9/16" Nylok jam nut
6. Threaded stud
7. Adjustment knob (SA Only)
8. Screw
9. Snap ring

# COILOver

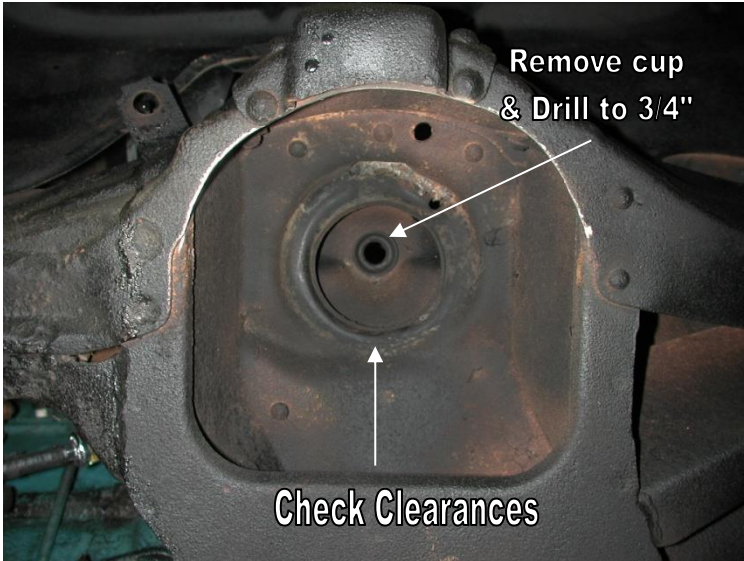

1. To allow the step in the lower Delrin ball half to slide into the factory shock hole, the bushing cup will need to be removed (if your car has one) and the hole may need to be drilled out to  $\frac{3}{4}$ ".

2. Assemble the CoilOver then place into the coil spring pocket w/ the stud and lower Delrin ball sticking through the factory shock hole.

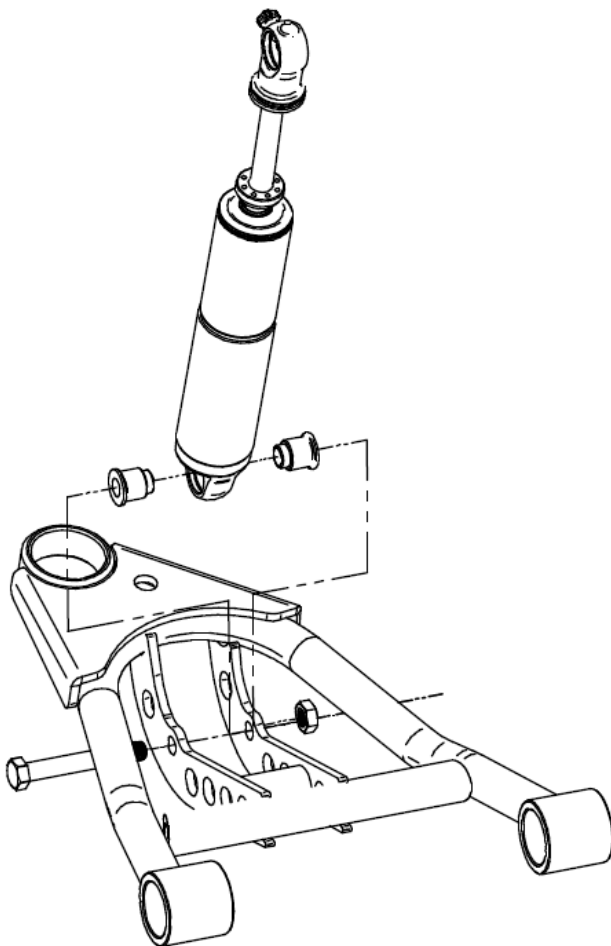

3. Check clearance between the upper factory spring retaining lip and stud top base or upper coil spring retainer. Allowing this to hit could cause the shock to break.

4. Place the upper Delrin ball over stud, then the aluminum cap. Secure the assembly w/ the 9/16" Nylok jam nut.

5. Attach the bottom of the shock to the lower StrongArms using the spacers and hardware supplied w/ the arm.

## Ride Height

We have designed most cars to have a ride height of about 2" lower than factory. To achieve the best ride quality & handling, the shock absorber needs to be at 40-60% overall travel when the car is at ride height. This will ensure that the shock will not bottom out or top out over even the largest bumps. Measuring the shock can be difficult, especially on some front suspensions. Measuring overall wheel travel is just as effective and can be much easier. Most cars will have 4-6" of overall wheel travel. One easy way to determine where you are at in wheel travel is to take a measurement from the fender lip (center of the wheel) to the ground. Then lift the car by the frame until the wheel is just touching the ground, re-measure. This will indicate how far you are from full extension of the shock. A minimum of 1.5" of extension travel (at the wheel) is needed to ensure that the shock does not top out. If you are more than 3" from full extension of the shock then you are in danger of bottoming out the shock absorber.

## Adjusting Spring Height

When assembling the CoilOver, screw the spring retainer tight up to the spring (0 preload). After entire weight of car is on the wheels, jounce the suspension and roll the car forward and backward to alleviate suspension bind.

- If the car is too high w/ 0 preload then a smaller rate spring is required. Although threading the spring retainer down would lower the car, this could allow the spring to fall out of its seat when lifting the car by the frame.
- If the car is too low w/ 0 preload, then preload can then be added by threading the spring retainer up to achieve ride height. On 2.6" - 4" stroke shocks, up to 1.5" of preload is acceptable. On 5-7" stroke shocks, up to 2.5" of preload is acceptable. If more preload is needed to achieve ride height a stiffer spring rate is required. Too much preload may lead to coil bind, causing ride quality to suffer.

## Shock adjustment 101- Single Adjustable

### Rebound Adjustment:

How to adjust your new shocks.

The rebound adjustment knob is located on the top of the shock absorber protruding from the eyelet.

You must first begin at the ZERO setting, then set the shock to a soft setting of 20.



-Begin with the shocks adjusted to the ZERO rebound position (full stiff). Do this by rotating the rebound adjuster knob clockwise until it stops.



-Now turn the rebound adjuster knob counter clock wise 20 clicks. This sets the shock at 20. (settings 21-24 are typically too soft for street use).

Take the vehicle for a test drive.



-if you are satisfied with the ride quality, do not do anything, you are set!

-if the ride quality is too soft increase the damping effect by rotating the rebound knob clock wise 3 clicks.

Take the vehicle for another test drive.



if the vehicle is too soft increase the damping effect by rotating the rebound knob clock wise 3 additional clicks.



-If the vehicle is too stiff rotate the rebound adjustment knob counter clock wise 2 clicks and you are set!

Take the vehicle for another test drive and repeat the above steps until the ride quality is satisfactory.

Note:

One end of the vehicle will likely reach the desired setting before the other end. If this happens stop adjusting the satisfied end and keep adjusting the unsatisfied end until the overall ride quality is satisfactory.



**Part # 11282899**  
**65-70 Impala Front Lower StrongArms**  
For use w/ Shockwaves or CoilOvers

**Components:**

1	90000093	Driver side lower arm
1	90000094	Passenger side lower arm
2	90002586	Ball joint
2	90000928	Bushing
2	90001045	Control arm pivot bearing
2	90000734	Bearing housing
2	90000735	Bearing retaining plate
2	90000733	Aluminum bearing spacer
2	90000732	Bearing stud (Set to 3 1/16")
4	90002062	Aluminum spacer – Shock to lower arm

**Hardware:**

2	99752001	3/4"-16 Lock nut Gr.8	Pivot bearing
2	99752004	3/4"-16 Jam nut	Pivot bearing
2	99753001	3/4" Flat washer	Pivot bearing
6	99371018	3/8" x 1 1/4" SHCS	Pivot bearing
6	99373005	3/8" Lock washer	Pivot bearing
2	99501024	1/2" x 3 1/4" SAE Gr. 8 bolt	Shockwave to lower arm
2	99502001	1/2"-13 Nylok nut	Shockwave to lower arm
2	99371004	3/8" x 1 1/4" USS bolt	Steering stop
2	99372004	3/8" USS regular nut	Steering stop

# STRONG ARMS™

by Air Ride Technologies

## Installation Instructions

1. Raise and support vehicle at a safe, comfortable working height. Let the front suspension hang freely.
2. Remove the coil spring, shock absorber, upper and lower control arms, sway bar and the strut rods. **There is a washer on each side of the lower control arm frame bushing, these will be reused. The factory lower control arm bolt will be reused as well.**

**Note:** This kit is designed for use with our MuscleBar sway bar. It is easier to install it **before** the lower arms. The factory sway bar will not fit.



3. Bolt the lower StrongArm to the frame using the factory bolt. **Be sure to reinstall the T washers that came off the factory arm bushing.**

4. The front leg of the lower arm will attach to the frame in place of the strut rod. Refer to the diagram on the next page for assembly order.

**Note:** The hole in the frame may need to be buffed to allow bearing assembly to slide in.

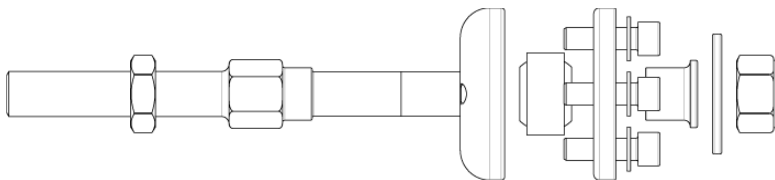

5. Using the bearing retainer as a template; drill three 3/8" holes in the frame to secure the assembly. Use three 3/8" x 1 1/4" SHCS and lock washers to secure the assembly.



6. Attach the Shockwave to the lower control arm using a  $\frac{1}{2}$ " x 3" bolt and Nylok jam nut. An aluminum spacer must be installed on each side of the bearing.

7. Two  $\frac{3}{8}$ " x  $1\frac{1}{4}$ " bolts and nuts are supplied for the steering stop. They will bolt to the rear side of the ball joint plate. This can be adjusted to limit steering radius.



8. The Caster setting on this system has a lot of adjustment. We recommend setting it at 3-3.5 degrees.

9. Driving height pressure should be around 100psi. 6-8 clicks in the shocks will be a good starting point. This will vary to vehicle weight and driver preference.

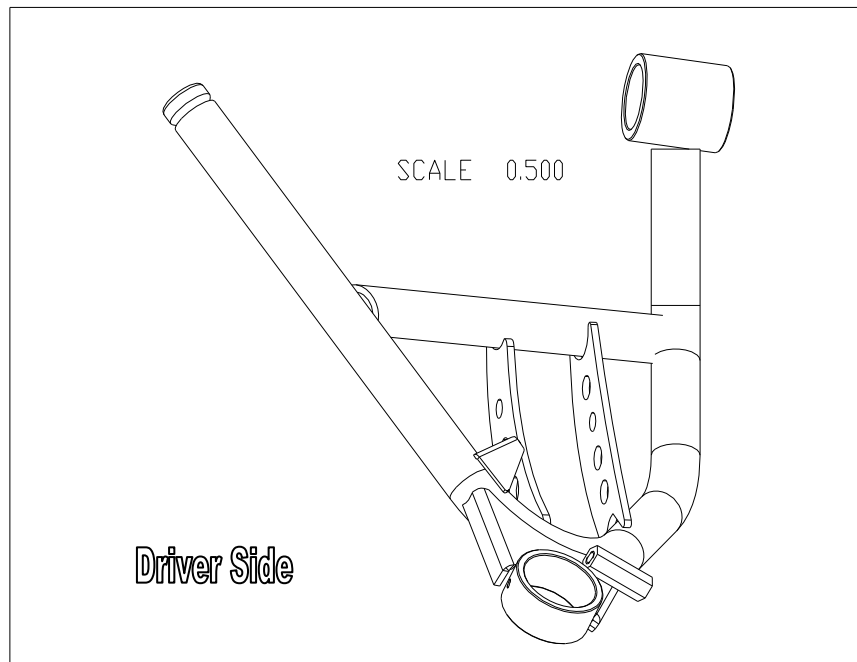





**Part # 11283699**  
**65-70 Impala Front Upper StrongArms**

**Components:**

1	90000478	Driver side upper arm
1	90000479	Passenger side upper arm
2	90000905	Ball joint (includes boot, grease fitting, castle nut & cotter pin)
4	90000907	Upper control arm bushing
2	90000102	Cross shaft

**Hardware:**

4	99373005	3/8" Lock washer	Upper cross shaft
4	99371013	3/8"-24 x 1" SAE bolt	Upper cross shaft
4	99373001	3/8" fender washer	Upper cross shaft

## 11283699 Installation Instructions



1. Drop the ball joint down through the ball joint plate, secure w/ the hardware supplied.
2. Fasten the upper arm to the frame using the factory hardware. Reinstall the current alignment shims, but **vehicle must be realigned**. This arm was designed with an extra 2 degrees of positive caster allowing the car to be aligned with up to 4 degrees of positive caster. (This will vary from car to car.)

### Driver Side – Top View

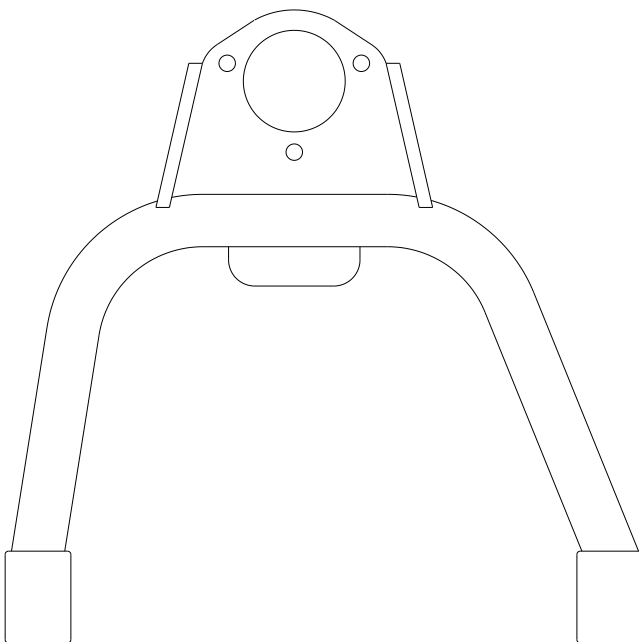

3. Insert the ball joint stud through the spindle and install new castle nut and cotter pin supplied.
4. Thread Zerk fitting into ball joint and grease.
5. Position the suspension at mid travel and then tighten the cross shaft nuts.

# STRONG ARMS™

by Air Ride Technologies

Item #	Description	Qty.
1.	Passenger side arm	1
1.	Driver side arm	1
2.	Cross shaft	2
3.	Cross shaft bushing	4
4.	Ball joint	2
5.	5/16"-24 x 1" hex bolt	6
6.	5/16"-24 hex nut	6
7.	5/16" lock washer	6
8.	3/8"-24 x 1" hex bolt	4
9.	3/8" lock washer	4
10.	3/8" x 1.5" flat washer	4

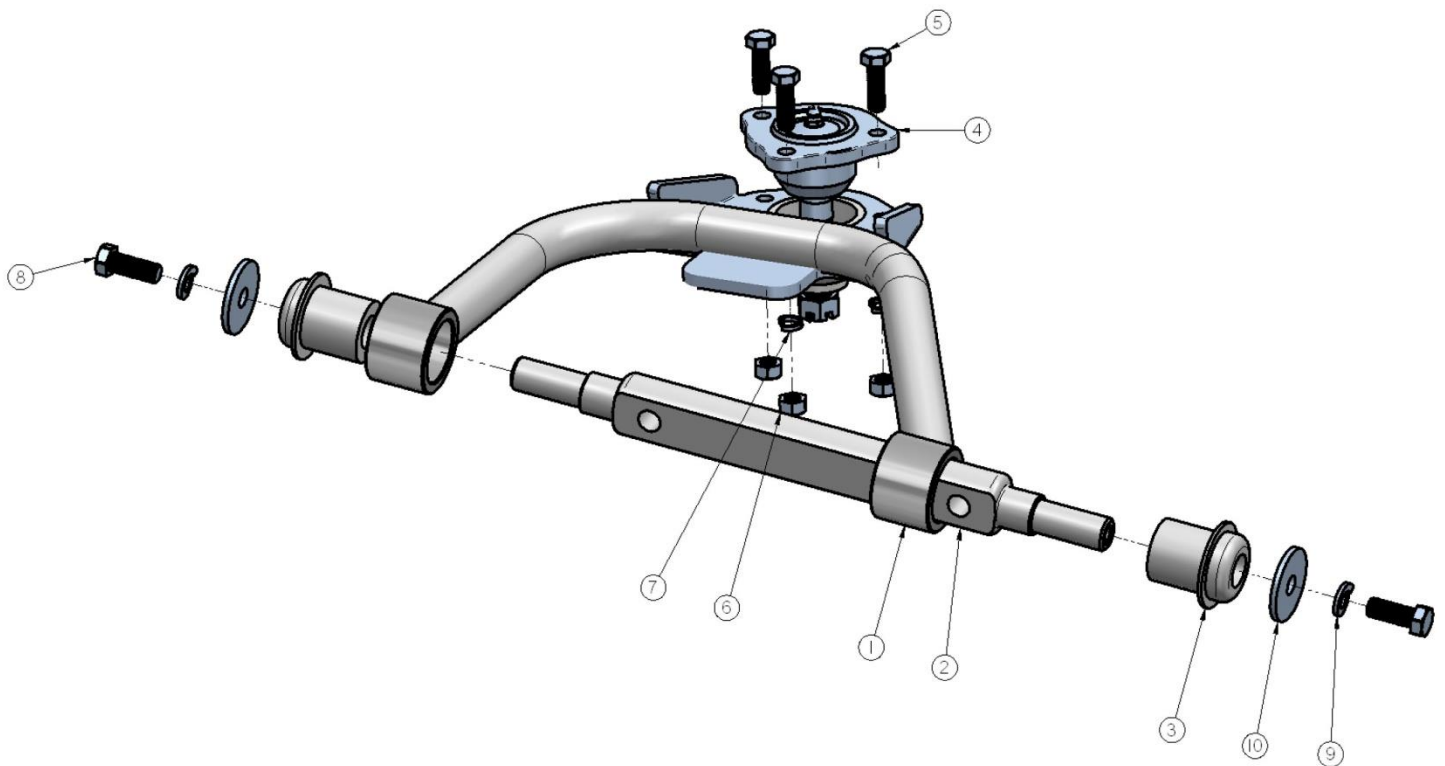



**Part # 11289100**  
**65-70 Impala Front MuscleBar**

**Components:**

1	90000104	Sway bar
2	90001100	Bushing and strap kit
2	90000929	12mm end link
2	90001092	Tube of Lithium grease

**Hardware Kit: 99010042**

2	99122001	12mm x 1.75	Lock nut	PosiLink to lower arm
4	99433002	7/16"	SAE flat washer	PosiLink to lower arm
2	99122007	12mm	lock washer	PosiLink to sway bar
4	99371004	3/8" x 1 1/4"	USS bolt	Frame bracket
4	99372002	3/8"	USS Nylok nut	Frame bracket
8	99373003	3/8"	SAE flat washer	Frame bracket

**MUSCLEbar**<sup>™</sup>  
*by Air Ride Technologies*

# MUSCLEbar™

by Air Ride Technologies

## 11289100 Installation Instructions

\*\*\*\*This sway bar is designed for use with our front StrongArms\*\*\*\*

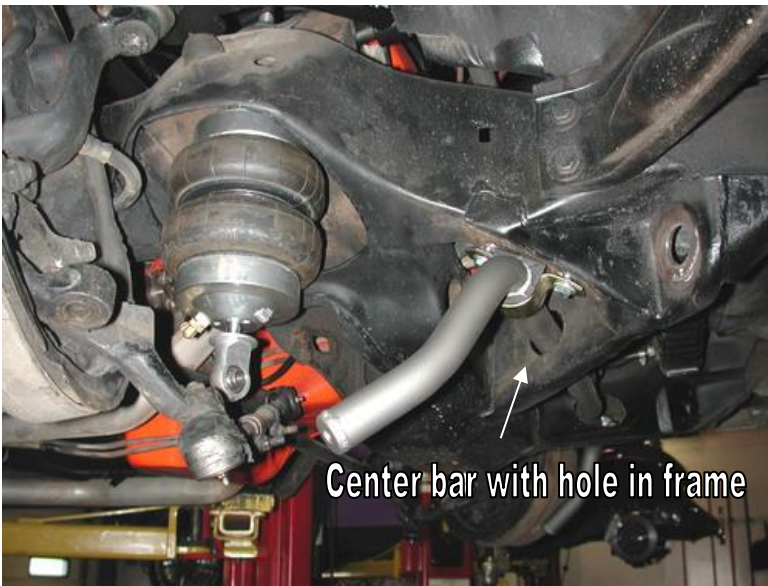

1. Slide the sway bar through the same holes in the frame that the factory bar went through.
2. Install the new polyurethane bushing over the sway bar. Lubricate with the Lithium grease supplied.
3. Slide the frame bracket over the bushings and clamp the sway bar up to the frame using a couple "C" clamps. The sway bar should be centered in the hole through the frame.



4. Adjust the frame bracket so that the corner of the bracket is flush with the outside of the frame rail.
5. The factory bolt holes will not be used. Two new holes must be drilled with a 3/8" bit.
6. Secure the assembly with two 3/8" x 1 1/4" bolts, flat washers and Nylok nuts.



7. Install the lower StrongArms.

8. Screw one end of the PosiLink into the end of the sway bar. A 12mm lock washer will be used between the stud and the sway bar.



9. The other end of the PosiLink will attach to the tab on the StrongArm using a 12mm flat washer and locking nut.

10. Check sway bar clearance through full suspension travel.





**Part # 11280701**  
**65-70 Impala HQ Series Rear Shock Kit**

**Shock:**

2	22989999	HQ Smooth Body Shock Cartridge
2	70011139	5/8" ID Shock Bushing
2	70011138	3/4" ID Shock Bushing
2	90002103	5/8" ID Shock Sleeve
2	90002068	Wide Trunion

**Components:**

2	90000471	Aluminum shock spacer
2	90001619	Shock stud

**Hardware:**

4	99311001	5/16" x 1" USS bolt	Shock to frame
8	99313002	5/16" SAE flat washer	Shock to frame
4	99312003	5/16" USS Nylok nut	Shock to frame

# ridetech

## Installation Instructions



1. Attach the upper T-bar to the frame in the oem location using the supplied 5/16 x 1" USS bolts, washers and Nylok nuts.



2. Attach the shock to the axle using the new cantilever pin supplied.





**Part # 11284499**  
**65-70 Impala Rear Lower StrongArms**  
For use w/ CoolRide

**Components:**

2	90001027	Lower arm – WW 22.5"
4	90001085	Poly bushing half
2	90001089	Poly bushing half (Rear)
2	90001086	Poly bushing half (Front)
2	90000722	Inner bushing sleeve - 2.625" long x .625" I.D x .75" O.D. (Rear)
2	90000467	Inner bushing sleeve - 2.5" long x .625" I.D. x .75" O.D. (Front)
2	90001092	Tube of Lithium grease

**Hardware:**

4	99621006	5/8" x 3 3/4" SAE Gr. 8 bolt	Upper and lower arms
4	99622006	5/8" SAE Nylok jam nut	Upper and lower arms/panhard bar stud



1. Clean the bushing surfaces on the frame and axle brackets. Lubricate with the lithium grease supplied.
2. Fasten the StrongArm to the frame and axle using the 5/8" x 3 3/4" bolts and Nylok jam nuts supplied.



**Part # 11306699**  
**67-70 Impala Rear Upper StrongArm & Panhard Bar Kit**

**Upper Arm Components:**

1	90002581	Upper StrongArm – C-C 10.00"
1	70013364	R-Joint Rod End housing
1	99752004	3/4"-16 SAE jam nut
4	70013544	R-Joint Spacer – <b>5/8" ID x 1.031" long</b>

**Panhard Bar Components:**

1	90002827	Panhard bar – TW 33.875" (C-C 35.75")
1	70013364	R-Joint Rod End housing
1	99752004	3/4"-16 SAE jam nut
1	90000461	Panhard bar axle stud
2	70013334	Axle Stud R-Joint Spacer – <b>5/8" ID x .620" long</b>
2	70013764	Frame Mount R-Joint Spacers – <b>9/16" ID x .620" long</b>

**R-Joint Components**

70013279	Retaining Ring
70013280	Wavo Wave Spring
70013276	R-Joint Composite Center Ball Cage
70013275	R-Joint Stainless Center Ball

**Hardware:**

2	99621006	5/8" x 3 3/4" SAE Gr. 8 bolt	Upper arm
3	99622006	5/8" SAE Nylok jam nut	Upper arm / panhard bar stud
1	99561003	9/16" x 3" SAE Gr. 8 bolt	Panhard bar to frame
2	99562001	9/16" SAE Nylok jam nut	Panhard bar
1	99563001	9/16" USS flat washer	Panhard bar stud
1	99603003	5/8" USS flat washer	Panhard bar stud

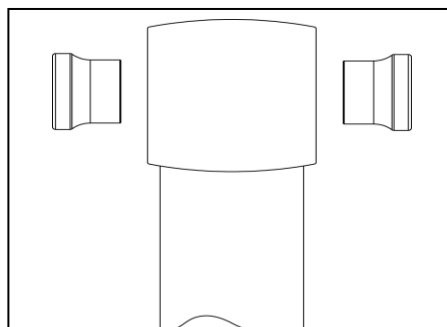

Insert the **SMALL** end of the spacer **INTO** each side of the center pivot ball. Push the spacer in until it bottoms out in the center pivot.

# STRONG ARMS™

by Air Ride Technologies

## Installation Instructions



1. Replace the factory upper trailing arm with the StrongArms. 5/8" x 3 3/4" bolts and Nylok jam nuts are supplied to replace the factory hardware. A 5/8" ID x 1.031" long spacer will need to be inserted into each side of the R-Joint.

**Note:** Some cars may have two upper arms. In this case you will need to order a second upper arm, part # 11306698



2. Replace the factory panhard bar with the new one using the new stud and hardware supplied. Insert the 5/8" Inside Diameter R-Joint Spacers into the R-joint of one end of the Panhard Bar.

**Check air spring clearance through full suspension travel. Allowing the air spring to rub will result in failure and is not a warrantable situation.**



3. The other end of the Panhard Bar will attach to the frame using the 9/16" x 3" bolt and Nylok nut. Insert the 9/16" Inside Diameter R-Joint Spacers into the R-joint

4. The panhard bar should be approximately 35 3/4" center eye to center eye, but may need adjusted to center the axle. This should be checked at ride height.



**Part # 11284799**  
**65-70 Impala Rear Coil Spring Kit**

**Components:**

2	59130325	Coil spring – 13" free length, 5" O.D., 325# rate
2	90002079	Lower spring retainer

**Hardware:**

2	99371001	3/8" x 3/4" USS bolt	Spring retainer to lower arm
2	99373005	3/8" lock washer	Spring retainer to lower arm



1. Attach the spring retainer to the lower trailing arm using the 3/8" x 3/4" bolt and lock washer.



2. Support the axle, then remove the lower shock bolt. This will allow the axle to drop low enough to install the spring into the pockets.



**Part # 11289102**  
**65-70 Impala Rear MuscleBar**

**Components:**

1	90001782	Rear sway bar <i>(Includes the following)</i>
	2	1" I.D. Polyurethane bushings
	2	Bushing clamp
4	90000926	90 degree 10mm PosiLinks
1	90000738	Sway bar frame bracket
1	90000739	Sway bar frame bracket
2	90000740	Sway bar axle bracket
2	90000088	U Bolts 7/16"-20 x 4 1/2" tall x 3 1/4" wide
2	99115001	10mm Posi Link studs In PosiLink (use Loctite)
2	90002275	Aluminum crush washer In PosiLink
2	90001092	Tube of lithium grease

**Hardware Kit: 99010043**

3	99431002	7/16"-14 x 1 1/4" USS bolt	Upper bracket
6	99432001	7/16-14" USS Nylok nut	Upper bracket
4	99432002	7/16"-20 Nylok Nut	U bolt
13	99433002	7/16" SAE flat washer	U bolt / upper bracket
4	99122001	10mm Nylok nut	PosiLink
8	99373003	3/8" SAE flat washer	PosiLink

**MUSCLEbar™**

# MUSCLEbar™

## 11289102 Installation Instructions

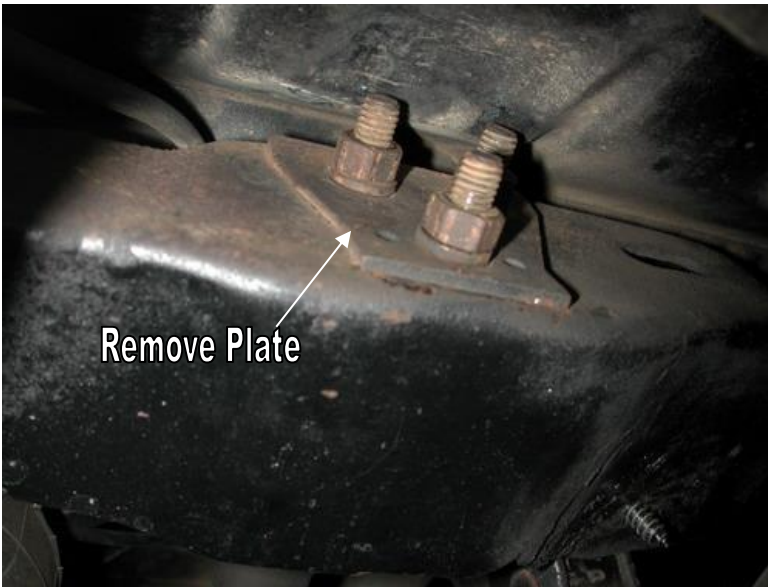

1. Loosen the 3 nuts holding the upper bar bracket to the cross member on the passenger side of the car. Remove the reinforcement plate.

2. Install the new sway bar frame mount using the 7/16" flat washer and Nylok nuts supplied. The tab for the PosiLink will face towards the outside of the vehicle, the image below shows the passenger side.

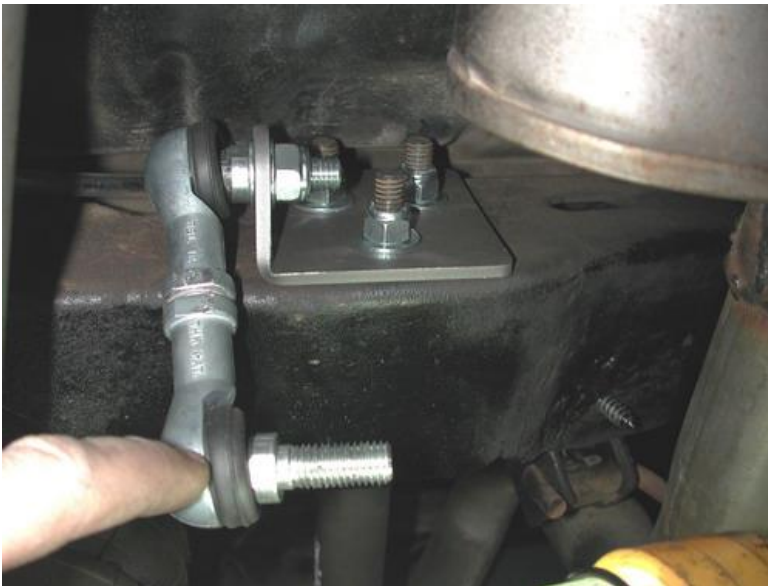

3. Most cars do not have an upper bar on the driver side, but the 3 bolt holes are there. 7/16" x 1 1/4" bolts, flat washers and Nylok nuts are supplied to fasten the bracket to the frame.

4. Fasten the PosiLink to the upper bracket using a 10mm Nylok nut. A 3/8" flat washer needs to be installed on each side of the bracket.

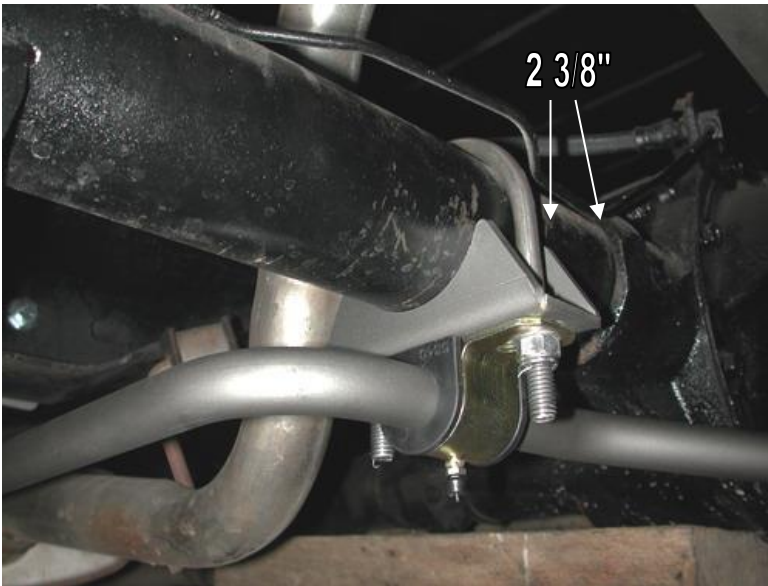

5. Attach the axle bracket, bushing and bushing bracket to the axle using the U bolt, 7/16" Nylok nut and flat washers supplied.

6. The inside edge of the axle bracket should be 2 3/8" from the center section. If you are using an aftermarket axle the brackets should be 21 7/8" apart, from inside to inside.

**Note:** Be sure not to put the bar on upside down. The back section of the bar should drop down to allow differential cover access.



7. Attach the sway bar to the PosiLink using a 10mm Nylok nut and two 3/8" flat washers.



8. Check MuscleBar clearance through full suspension travel.

Congratulations!!! Your new MuscleBar installation is now complete.