



**Installation  
Instructions**



**Part # 11210311 - 1993-2002 GM "F" Body Level 3 CoilOver System**

**Front Components:**

11213111          Front Coilovers

**Rear Components:**

11216111          Rear Coilover Instructions

**Miscellaneous Components:**

85000000          Spanner Wrench

**Recommended Tools**

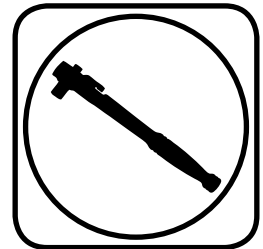

# 1993-2002 F Body Level 3 Coilover Installation Instructions

**Table of contents**

Pages 2-7..... Front TQ Series CoilOvers

Pages 8-13.....Rear TQ Series Coilovers

Pages 14-15.....Coilover Preload and Adjustment



### Part # 11213111 - 1993-2002 F Body TQ Front CoilOvers

#### Recommended Tools

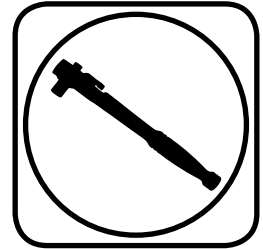
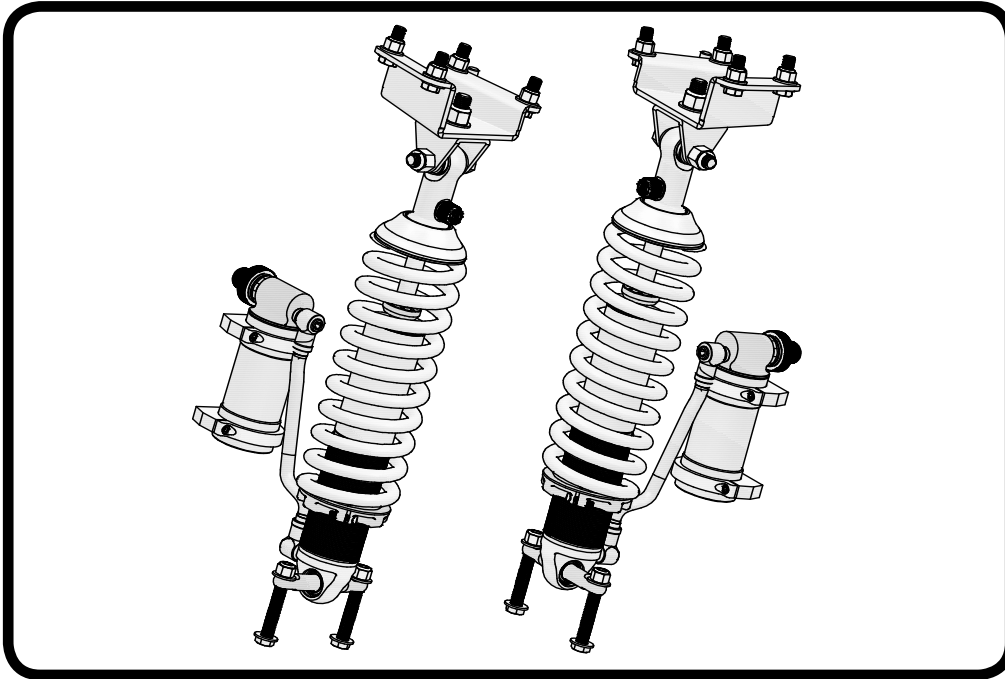

## 1993-2002 GM F Body TQ Series Front CoilOvers Installation Instructions

#### Table of contents

- Page 3..... Included components
- Page 4..... Hardware List and Getting Started
- Page 5..... CoilOver Assembly and Installation
- Page 6-7..... Upper Mount Assembly and Installation



### Major Components .....In the box

Item #	Part #	Description	QTY
1	24269999	6.3" Stroke TQ Series Shock	2
2	90001692	F Body Trunion (Installed in Shock)	2
3	90002221	Reservoir Mount	4
4	99371033	3/8" -16 x 3" Hex Bolt	4
5	70010828	Delrin Spring Washer	4
6	90002222(kit)	Lower Spring Adjuster Nut (90002222 kit)	2
7	90002222(kit)	Adjuster Nut Locking Screw (90002222 kit)	2
8	90002070	Upper CoilSpring Retaining Plate	2
9	90002025	Upper Shock Eyelet	2
10	90002043	Upper Eyelet Bearing Spacers	2
11	90009982	Upper Shock Mount	2
12	90002305	Upper Shock Mounting Bracket DRIVERS	1
12	90002306	Upper Shock Mounting Bracket (PASSENGER)	1
	90001994	5/8" ID Bearing (installed in shock eyelet)	2
	90001995	Bearing Snap Ring (installed in shock eyelet)	4
	59120350	12" 350lb CoilSpring	2

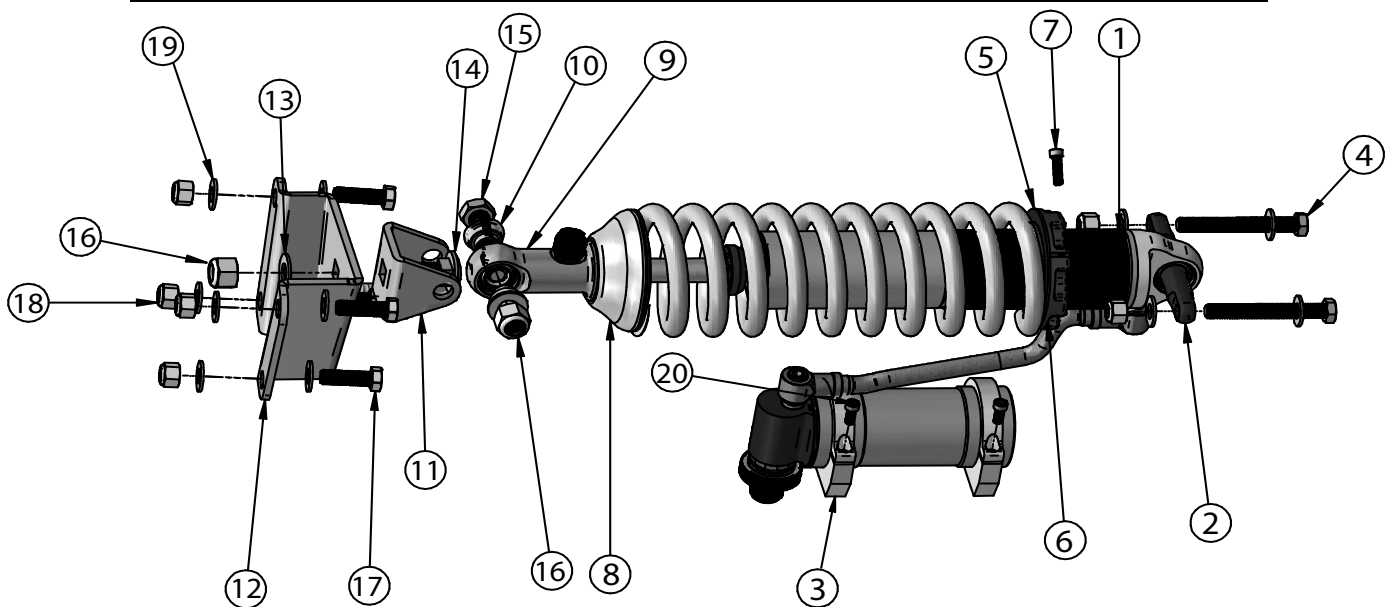



### Hardware List .....In the box

QTY	Part Number	Description	
2	99503001	1/2" SAE Flatwasher	Upper Shock Mount to Bracket (13)
2	99501018	1/2" Carriage Bolt	Upper Shock Mount to Bracket (14)
2	99501003	1/2"-13 x 2 1/2" Hex Bolt	Upper Shock To Mount (15)
4	99502001	1/2"-13 Nylok Nut	Upper Shock Mounting (16)
8	99371004	3/8"-16 x 1 1/4" Bolt	Upper Shock Mount to Car(17)
12	99372002	3/8"-16 Nylok Nut	Upper Shock Mount to Car and Bumpstop (18)
24	99373003	3/8" Flatwasher	Upper Mount to Car, Bumpstop, Trunnion(19)
12	99050000	5mm SHCS	Reservoir Mount (20)

### Getting Started.....

Congratulations on your purchase of the Ridetech F Body CoilOver System. This system has been designed to give your F Body excellent handling along with a lifetime of enjoyment. The CoilOver System provides fl exibility that can not be achieved with Conventional CoilSpring. The CoilOver System will give you the fl exibility of adjusting your ride height along with numerous spring options to dial in your ride quality to your personal preference.

1. The front OEM Shocks and Springs will need to be removed from the front of the car.
2. Raise the vehicle and support it by the frame or rear crossmember allowing the suspension to hang freely.
3. Support The lower Control Arm with a Jack or Jack Stand. The upper shock mount is also used to attach the upper control arm. When you remove the upper shock mount the spindle will want to swing out. Don not allow it to swing out or it can damage your brake lines.
4. Unbolt the lower shock mount from OEM Control Arm.
5. Unbolt the upper Shock mount and remove the OEM Shock and Spring setup from the car.
6. With the Shocks and CoilSprings removed you are ready to start assembling the CoilOvers and install them in your Camaro.

To get Started refer to the page 4 on how to assemble the CoilOver



### CoilOver Assembly



1 First using the supplied lower adjuster nut(90002222) thread the nut onto the shock from the top side as seen in figure 1



4 Slide the Derlin washer over the spring, Next slide the upper spring mount (90002222) over eyelet as seen in figure 4.



2 Next install delrin washers then coil spring over the top of the shock as seen in figure 2



5 Install upper spring mount retainer clip (90002057) into the groove on the upper eyelet as seen in figure 5. Then reinstall adjuster to complete assembly.



3 Before the upper spring mount can be installed screw the adjuster knob on the upper eye mount to the firmest setting (clockwise) as seen in figure 3. and remove knob.

### CoilOver Installation



7. Using the 1/2" Carriage Bolt, 1/2" Flat-washer, and 1/2" Nylok, bolt the Upper Shock Mount to the upper bracket. The squares in the brackets should be aligned with the square shank on the carriage bolt. With the squares aligned tighten the mount. With the 2 pieces bolted together, bolt them into the car using (4) 3/8"-16 x 1 1/4", (8) 3/8" Flatwashers, and (4) 3/8" Nylok nuts. There is Driver and Passenger Bracket and this have a "D" and "P" stamped in them. Tighten all hardware.



### Upper Mount Assembly and Installation

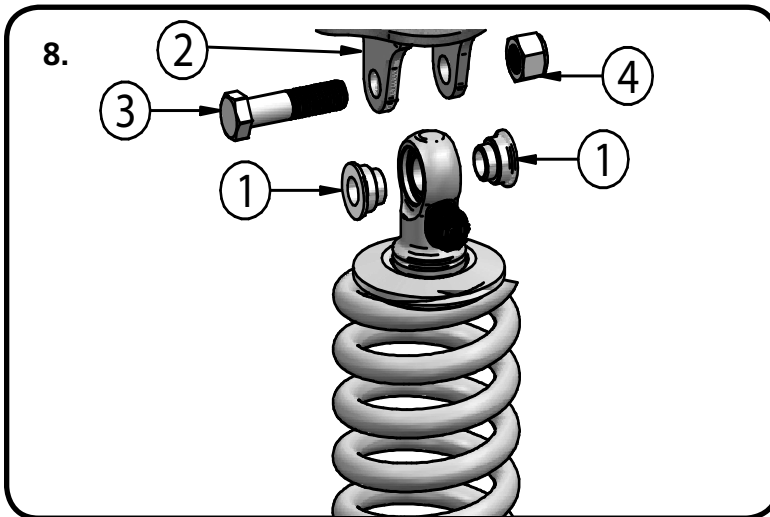

8. With the CoilOver assembled insert the upper spacers(1) into the upper shock bearings. With the spacers installed insert the CoilOver assembly into the upper shock mount(2). Align the holes in the bracket with the hole in the Shock spacers and insert the 1/2" Bolt(3) and secure with the 1/2" Nylok Nut(4).



9. Attach the lower CoilOver mount to the OEM Lower Control Arm using (2) 3/8"-16 x 3" Bolts, (4) 3/8" Flatwashers, and (2) 3/8"-16 Nylok Nuts. Tighten Hardware. It may be necessary to raise the lower control arm up to align the CoilOver with the OEM Mount.



10. Tighten the lower Coilspring Adjusting nut until the Coilspring is sitting snugly on the CoilOver. Using the Spanner wrench add another 1/2" of preload in the spring by threading the adjuster nut up the Shock Body. Be sure that the locking screw is lightly tightened in the adjuster nut. Once you have preloaded tighten the locking screw. It may be necessary to add more preload, this will be determined once the car is setting on the ground.



### Upper Mount Assembly and Installation

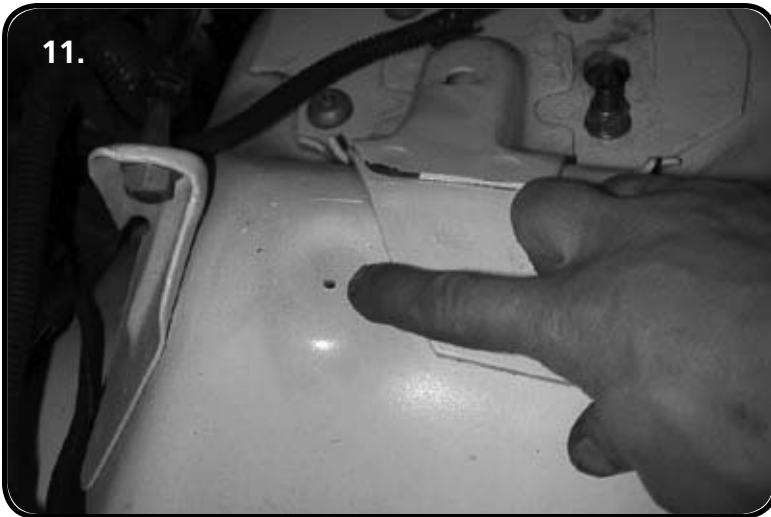

**11.** A bump stop will be installed between the inner fender and upper control arm to ensure that the tire does not hit the inner fender when fully compressed. There is a small hole on the inner fender that must be drilled out to 3/8". Fasten the bump stop to the inner fender using a 3/8" Nylok nut and flange washer.



**Part # 1121611 - 1982-2002 GM F-Body Rear CoilOvers**

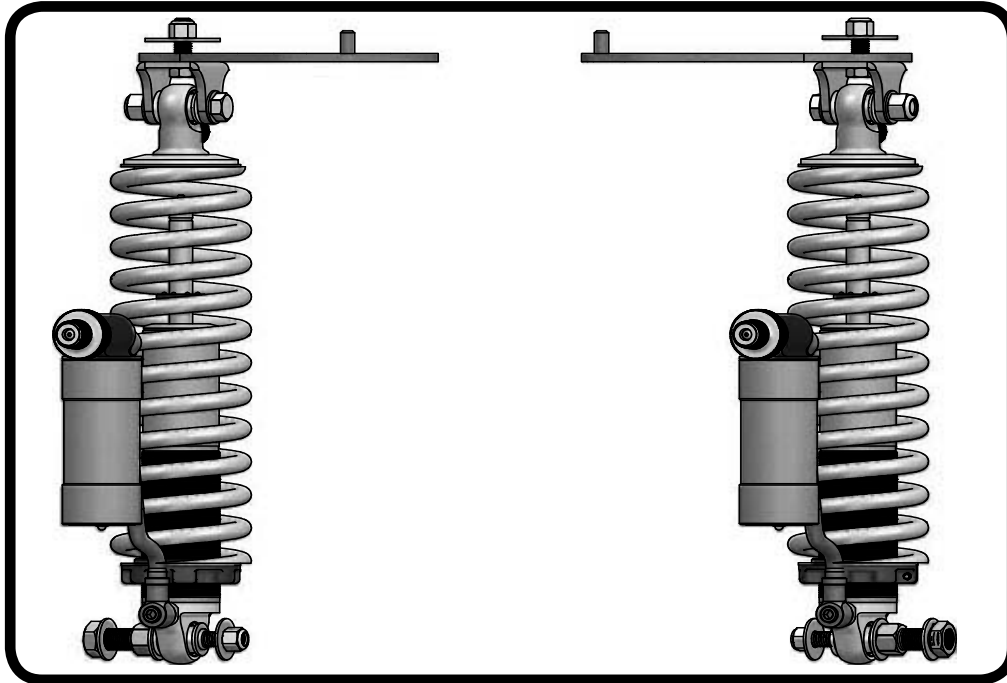

Recommended Tools

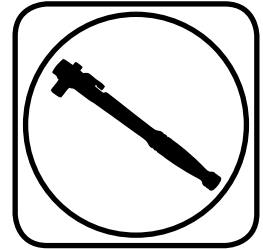

## 82-02 F-Body TQ Series Rear Coilovers Installation Instructions

### Table of contents

Page 9.....	Included components
Page 10.....	Hardware List and Getting Started
Page 11.....	CoilOver Assembly and Installation
Page 12.....	Installation
Page 13.....	Final Assembly and Setting Spring Height
Page 14.....	Setting Spring Height and Shock Adjustment
Page 15.....	Shock Adjustment





### Major Components .....In the box

Item #	Part #	Description	QTY
1	24259999	5.2" Stroke TQ Series Shock	2
2	90002222	Coilspring Kit	2
3	70010828	Delrin Spring Washer	4
4	59100200	Coilspring 10" 200lb	2
5	90002067	5/8" ID Lower Bearing Spacers	4
6	90001617	Lower Coilover Mounting Stud with hardware	2
7	90002024	Shock Eyelet	2
8	90001994	5/8" ID Bearing (installed in shock and eyelet)	4
9	90001995	Bearing Snap Ring (installed in shock and eyelet)	8
10	90002043	1/2" ID Upper Bearing Spacers	4
11	90000034	Upper Coilover Mount	2
12	90002150	Driver Upper Plate	1
12	90002151	Passenger Upper Plate	1
	90002221	Reservoir Mounts (Not Shown)	12
	85000003	Reservoir Mount Allen Wrench (Not Shown)	1

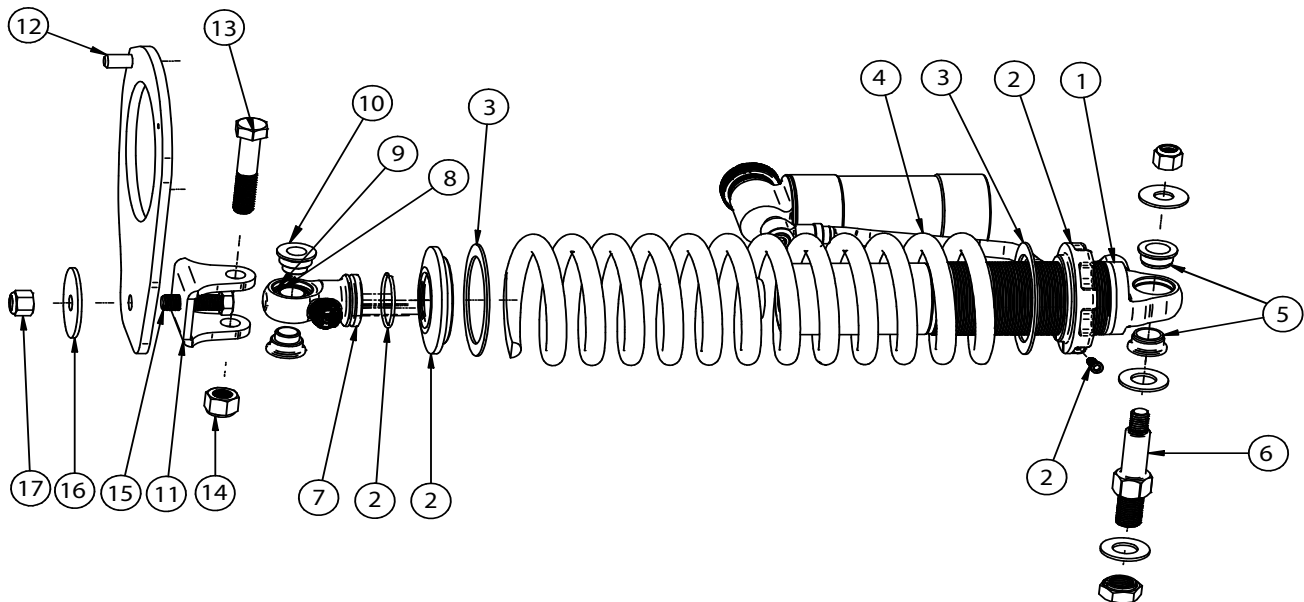



### Hardware List ....In the box

Item #	QTY	Part Number	Description	Location
13	2	99501003	1/2"-13 x 2 1/2" Bolt	Upper Coliover to Mount
14	2	99502001	1/2"-13 Nylok Nut	Upper Coliover to Mount
15	2	99431008	7/16"-14 x 1 1/2" Bolt	Upper Mount to Car Body
16	2	99432001	7/16"-14 Nylok Nut	Upper Mount to Car Body
17	2	99433001	7/16" x 2" Washer	Upper Mount to Car Body
	12	99055000	5mm SHCS	Reservoir Mounts (Not Shown)

### Getting Started.....

Congratulations on your purchase of the Ridetech Rear CoilOver System. This system has been designed to give your car excellent handling along with a lifetime of enjoyment. One of the key features of this system is the adjustability. With the CoilOver system you have an adjustable shock along with the height adjustment of the coil spring.

### Disassembly

1. The rear springs, shocks and bumpstops will need to be removed from the car.
2. With the car on a lift or jack stands, support the rear differential with a jack and disconnect the bottom of the shock from its mount on the rear differential.
3. With the shock disconnected, **slowly** lower the rear differential until the rear spring comes loose. **Pay attention to the brake hose so that you don't pull it apart.** Remove the springs from the car.
4. The carpet in the hatch area right behind the seat will have to be pulled back to gain access to the top of the shock. The top of the shock is located right behind the back seat. There is a piece of foam that covers the top of the shock.

**NOTE:** Keep in mind the spring has pressure on it until you let the rear differential down to remove the springs.



### Coilover Assembly



First using the supplied lower adjuster nut (90002222) thread the nut onto the shock from the bottom side as seen in figure 1



Slide the Derlin washer over the spring, Next slide the upper spring mount (90002222) over eyelet as seen in figure 4.

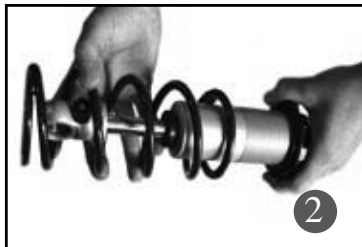

Next install delrin washers then coil spring over the top of the shock as seen in figure 2



Install upper spring mount retainer clip (90002057) into the groove on the upper eyelet as seen in figure 5. Then reinstall adjuster to complete assembly.



Before the upper spring mount can be installed screw the adjuster knob on the upper eye mount to the firmest setting (clockwise) as seen in figure 3.

### Coilover Installation

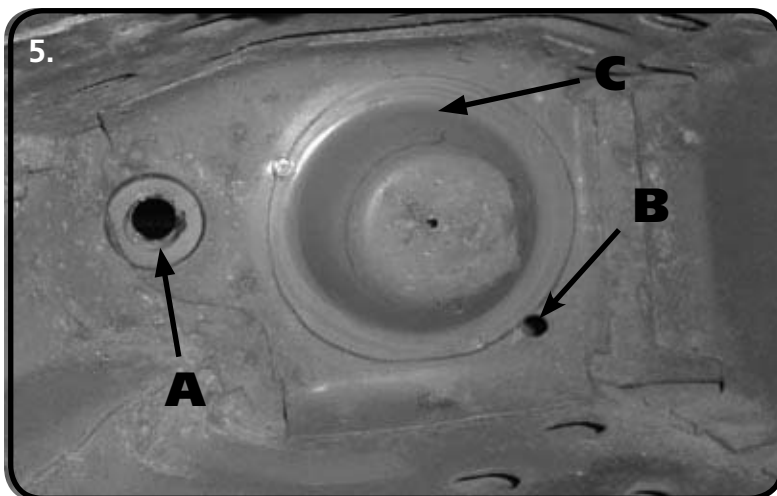

5. Picture "5" shows the factory upper coil-spring pocket in the car. (A) is the factory shock hole that the upper plate and mounting bracket will be bolted through, (B) is a locating hole in the body that will be used to help locate the new upper plate, (C) is the factory coilpring locator that will also help in locating the upper plate



### Installation

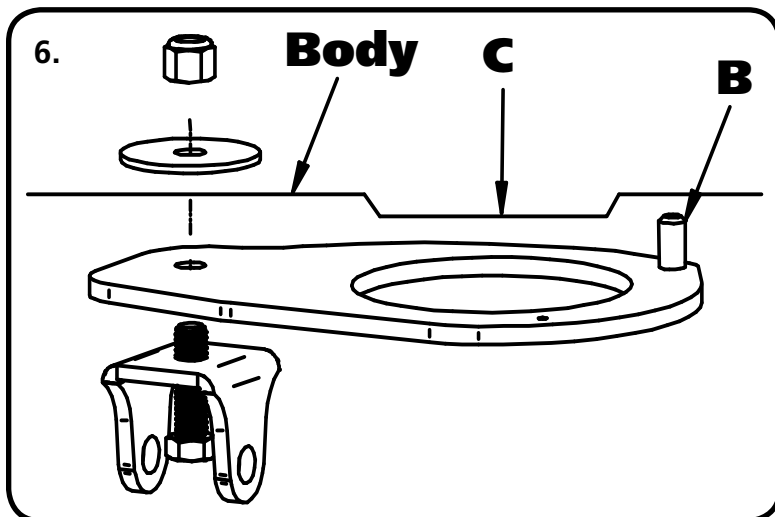

**6. This step is a 2 person job.** The upper plate and Coilover mount get bolted in the car using (1) 7/16" x 1 1/2" bolt, the large flat-washer and Nylok nut. Place the 7/16" bolt through the Upper mount and plate. Place the upper plate up into the factory coil spring pocket with the locating pin (B) going into the small hole. Put the 7/16" bolt through the Upper Mount and then insert it into the hole location at the factory shock hole. Have the person helping install the Large 7/16" washer and Nylok nut on the bolt from inside the vehicle.

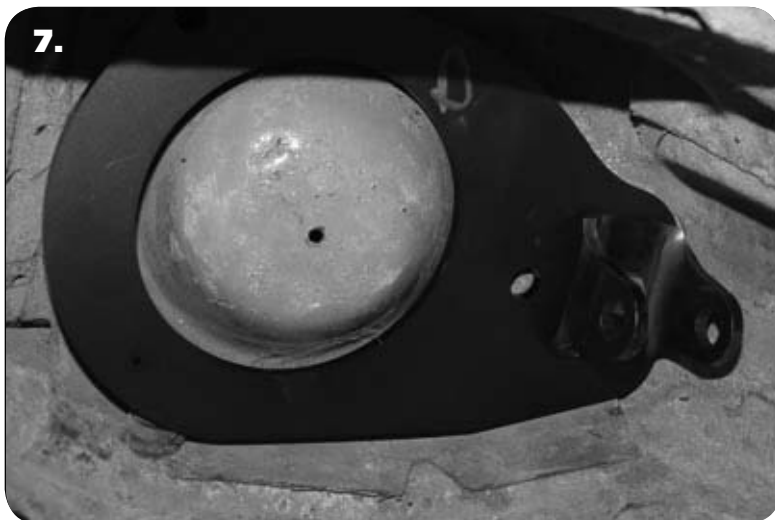

**7.** Tighten the 7/16" Nut and bolt with the help of the second person. When tightening be sure the upper mount is clocked in a manner that the upper CoilOver mounting bolt will be in line with the lower stud.

**Note:** The purpose of the upper plate is to distribute the load of the CoilOver over a larger area.

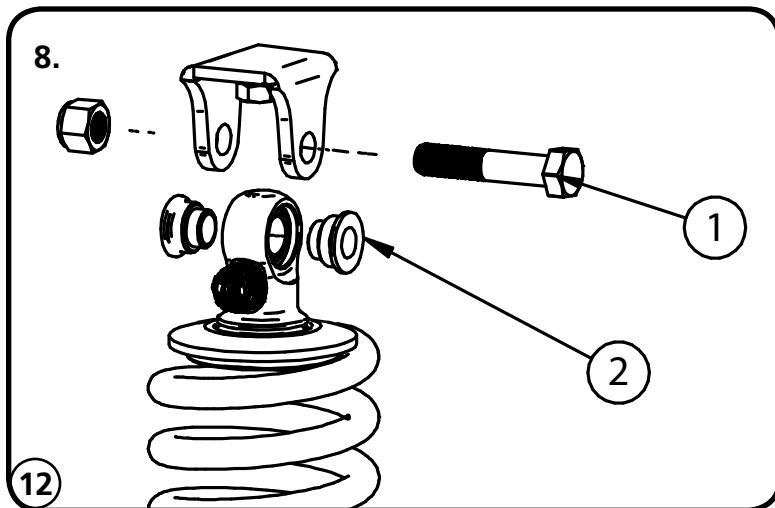

**8.** Install the 1/2" I.D. Spacers (1) into the bearing of the upper CoilOver eyelet. Insert the CoilOver into the upper mounting bracket aligning the holes in the spacers with the holes in the bracket. Insert 1/2" x 2 1/2" bolt through the bracket and CoilOver. Install 1/2" Nylok nut and tighten.



### Final Assembly

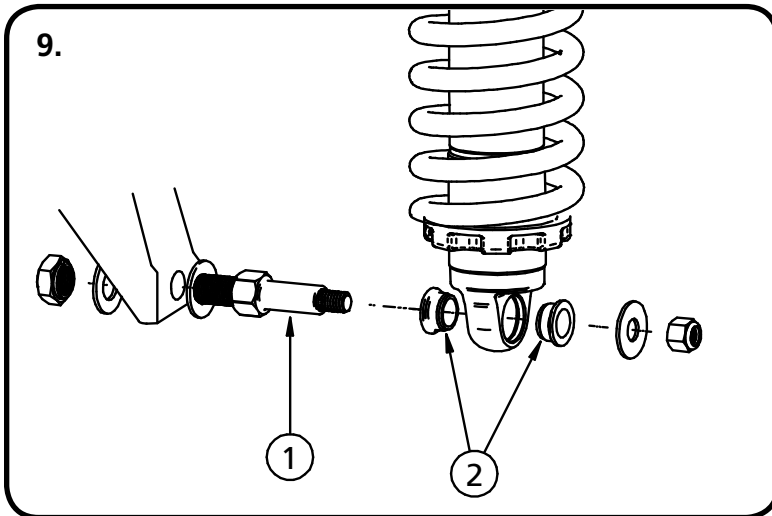

9. Drill the factory shock stud hole out to 5/8" , this can be done using a Unibit. Install the (1) Shock stud (90001617) into the factory lower mount using the hardware supplied with the stud. Install a 5/8" I.D. spacer on the shock stud, then the bottom of the ShockWave on the stud, followed by another 5/8" I.D. spacer. Install 7/16" washer and Nylok nut.

**Note:** It may be necessary to raise or lower the rear differential with the jack to get the lower shock bearing to line up with the stud.

### Setting Spring Height

#### Ride Height

We have designed most cars to have a ride height of about 1 1/2" " lower than factory. To achieve the best ride quality & handling, the shock absorber needs to be at 40-60% overall travel when the car is at ride height. This will ensure that the shock will not bottom out or top out over even the largest bumps. Measuring the shock can be difficult, especially on some front suspensions. Measuring overall wheel travel is just as effective and can be much easier. Most cars will have 4-6" of overall wheel travel. One easy way to determine where you are at in wheel travel is to take a measurement from the fender lip (center of the wheel) to the ground. Then lift the car by the frame until the wheel is just touching the ground, re-measure. This will indicate how far you are from full extension of the shock. A minimum of 1.5" of extension travel (at the wheel) is needed to ensure that the shock does not top out. If you are more than 3" from full extension of the shock then you are in danger of bottoming out the shock absorber.

#### Adjusting Spring Height

When assembling the CoilOver, screw the spring retainer tight up to the spring (0 preload). After entire weight of car is on the wheels, jounce the suspension and roll the car forward and backward to alleviate suspension bind.

- If the car is too high w/ 0 preload then a smaller rate spring is required. Although threading the spring retainer down would lower the car, this could allow the spring to fall out of its seat when lifting the car by the frame.
- If the car is too low w/ 0 preload, then preload can then be added by threading the spring retainer up to achieve ride height. On 2.6" - 4" stroke shocks, up to 1.5" of preload is acceptable. On 5-7" stroke shocks, up to 2.5" of preload is acceptable. If more preload is needed to achieve ride height a stiffer spring rate is required. Too much preload may lead to coil bind, causing ride quality to suffer.



### Setting Spring Height Continued

- If the car is too low w/ 0 preload, then preload can then be added by threading the spring retainer up to achieve ride height. On 2.6" - 4" stroke shocks, up to 1.5" of preload is acceptable. On 5-7" stroke shocks, up to 2.5" of preload is acceptable. If more preload is needed to achieve ride height a stiffer spring rate is required. Too much preload may lead to coil bind, causing ride quality to suffer.

### Shock Adjustment

#### Shock adjustment 101- Single Adjustable

##### Rebound Adjustment:

How to adjust your new shocks.

The rebound adjustment knob is located on the top of the shock absorber protruding from the eyelet.

You must first begin at the ZERO setting, then set the shock to a soft setting of 20.



-Begin with the shocks adjusted to the ZERO rebound position (full stiff). Do this by rotating the rebound adjuster knob clockwise until it stops.

-Now turn the rebound adjuster knob counter clock wise 20 clicks. This sets the shock at 20. (settings 21-24 are typically too soft for street use).

**Take the vehicle for a test drive.**



-if you are satisfied with the ride quality, do not do anything, you are set!

-if the ride quality is too soft increase the damping effect by rotating the rebound knob clock wise 3 clicks. **CONTINUE ON NEXT PAGE.**

**Take the vehicle for another test drive.**



-if the vehicle is too soft increase the damping effect by rotating the rebound knob clock wise 3 additional clicks.

-If the vehicle is too stiff rotate the rebound adjustment knob counter clock wise 2 clicks and you are set!

Take the vehicle for another test drive and repeat the above steps until the ride quality is satisfactory.

##### Note:

**One end of the vehicle will likely reach the desired setting before the other end. If this happens stop adjusting the satisfied end and keep adjusting the unsatisfied end until the overall ride quality is satisfactory.**



## Shock Adjustment

### Shock adjustment 101- Triple Adjustable

#### **Triple Adjustable:**

#### **Step One: High Speed Compression**



- High speed compression adjustments are used in both street driving and track tuning.
- Begin with the shocks adjusted to the ZERO high speed compression position (full stiff). Do this by rotating the high speed compression adjuster (large knob) clockwise until it stops.
- Now turn the high speed compression adjuster knob counter clock wise 20 clicks. This sets the shock at 20. (settings 21-24 are typically too soft for street use. For typical street driving the high speed compression adjuster will remain at setting 20.

#### **Step Two: Low Speed Compression**

Low speed compression adjustment is what is typically felt during street driving.



- Begin with the shocks adjusted to the ZERO low speed compression position (full stiff). Do this by rotating the low speed compression adjuster (small knob) clockwise until it stops.
- Now turn the low speed compression adjuster knob counter clock wise 20 clicks. This sets the shock at 20. (settings 21-24 are typically too soft for street use). Take the vehicle for a test drive.
- if you are satisfied with the ride quality, do not do anything, you are set!
- if the ride quality is too soft increase the damping effect by rotating the low speed compression knob clock wise 3 clicks.

#### **Take the vehicle for another test drive.**



- if the vehicle is too soft increase the damping effect by rotating the low speed compression knob clock wise 3 additional clicks.
- If the vehicle is too stiff rotate the low speed compression adjustment knob counter clock wise 2 clicks and you are set!

Take the vehicle for another test drive and repeat the above steps until the ride quality is satisfactory.

#### **Step 3:**

Adjust rebound according to Single Adjustable instructions.

#### **Note:**

**One end of the vehicle will likely reach the desired setting before the other end. If this happens stop adjusting the satisfied end and keep adjusting the unsatisfied end until the overall ride quality is satisfactory.**