

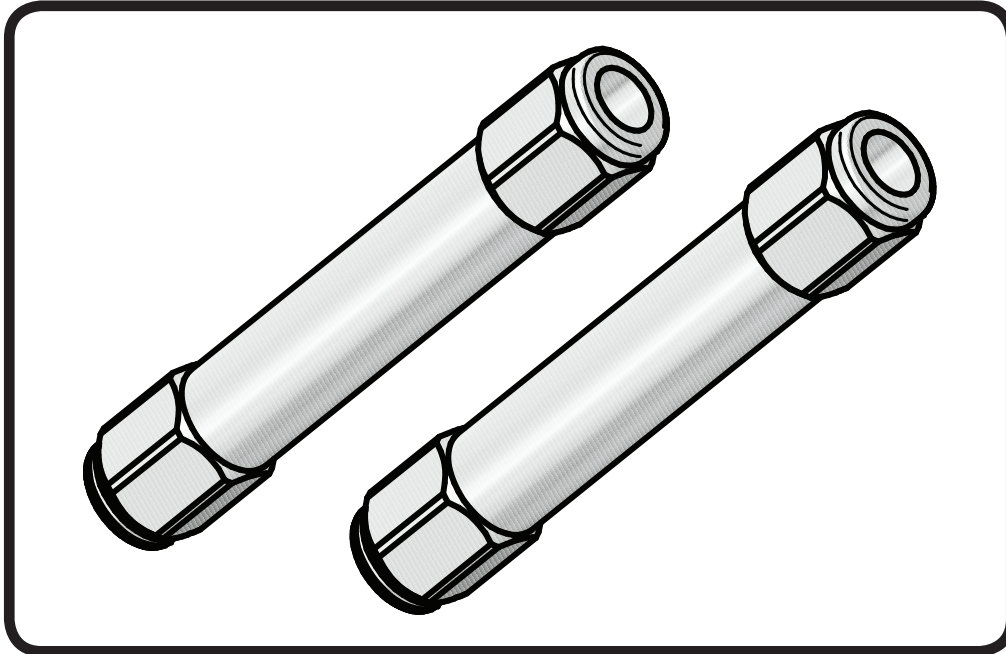

### Part # 11209400 - 82-02 Camaro Billet Tie Rod Adjuster

#### Recommended Tools



### Major Components .....In the box

QTY	Part Number	Description
2	90000728	Tie Rod Adjuster
2	99800002	5/8"-18 Right Hand Jam Nut
2	99800003	5/8"-18 Left Hand Jam Nut

#### NOTES:

This Tie Rod Adjuster is designed to take place of the OEM steel sleeve.

One end of the adjuster has a **groove** cut in it, this is the **LEFT HAND** threaded side.

When installing the Tie Rod Adjuster, use antisieze compound on the threads.

**FOR YOUR SAFETY, THE TIE RODS NEED A MINIMUM 15/16" OF THREAD ENGAGEMENT INTO THE TIE ROD ADJUSTER.**