

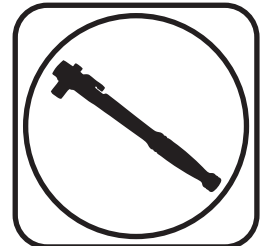

Part # 11175010/11175110 - 1970-1981 GM F-Body StreetGrip

Front Components	
11179590	Delrin Control Arm Bushings
90000913	Tall Upper Ball Joint
11172350/11172351	Front Dual Rate CoilSprings
22159847	Front HQ Series Shocks
11179120	Front Sway Bar
Rear Components	
11174799	Composite Leaf Springs
11175399	Delrin Leaf Spring Bushings
22199847	Rear HQ Series Shocks

Recommended Tools



1970-1981 GM F-Body Street Grip Installation Instructions

Table of contents	
Page 2.....	Major Components and Hardware List
Page 3.....	Getting Started
Page 4-12.....	Delrin Bushings
Page 13-14.....	Tall Upper Ball Joint
Page 15.....	Front Dual Rate CoilSpring
Page 16-18.....	Front Sway Bar
Page 19-23.....	Composite Leaf Springs & Delrin Bushings
Page 23-26.....	Front and Rear HQ Series Shocks

The majority of the StreetGrip components will be installed together. For example, the Front CoilSprings, Ball Joint, Control Arm Bushings and Shocks will be installed in conjunction with each other. On the rear, the CoilSprings and Shocks will be installed in conjunction with each other. The Sway Bars will, typically, be installed after the rest of the components are installed.



Major ComponentsIn the box

Part #	Description	QTY
56480700/56538800	Front CoilSprings	2
90002907	Rear Leaf Springs w/ Delrin Bushings & Inner Sleeves Installed	2
90002498	Upper Leaf Spring Clamp Plate	2
90002499	Lower Leaf Spring Clamping Plate	2
90000913	Tall Upper Ball Joint	2
90000896	Lower Ball Joint	
90002517	Delrin Bushing Outer Shell - Upper Control Arm	4
11179590	Delrin Control Arm Bushing Kit	1
Front & Rear Shocks		
986-10-043	5.25" Stroke Stud Top Shock - Front	2
70011139	5/8" ID Shock Bushing (Installed in Shock) - Front & Rear	4
90002068	Wide T-bar (Installed in Shock) - Front & Rear	4
70011140	Stud Top Bushing - Front	4
70011141	Stud Top Bushing Washer - Front	4
99372006	3/8"-24 Jam Nut - Front	4
986-10-020	7.55" Stroke Trunnion Top Shock - Rear	2
90002103	5/8" ID Shock Sleeve (Installed in Shock)	2
90001617	Shock Stud	2
90002510	Leaf Spring Plate	2
11169120	Front Swaybar Kit	1
90002496	Leaf Spring Shackle Plates	4
70012428	Frame Shackle Bushing	4
90000526	Frame Shackle Inner Bushing Sleeve	2
99501006	1/2"-13 x 3 1/2" Hex Bolt - Lower Control Arm	4
99501035	1/2"-13 x 5" Hex Bolt - Leaf Spring Bushings	6
99502009	1/2"-13 Nylok Nut - Lower Control Arm & Leaf Spring Bushings	10
99561010	9/16"-12 x 3 1/2" Hex Bolt - Lower Control Arm	4
99562006	9/16"-12 Nylok Nut - Lower Control Arm	4
99371050	3/8"-16 x 1 1/2" Conical Bolt - Front Leaf Mount	6
99372009	3/8"-16 U-Nut - Front Leaf Mount	6
99373005	3/8" Split Lock Washer - Upper Control Arm Bolts	4



Getting Started.....

Congratulations on your purchase of the Ridetech StreetGrip Kit. This system has been designed to give your Car excellent ride and handling along with a lifetime of enjoyment. Some of the key features of this Kit: Dual Rate CoilSprings, Delrin Control Arm Bushings, Larger Sway Bars with Delrin Liners and a Taller Upper Ball Joint.

The majority of the StreetGrip Components will be installed together. For example, the Front CoilSprings, Ball Joint, Control Arm Bushings and Shocks will be installed in conjunction with each other. On the rear, the CoilSprings and Shocks will be installed in conjunction with each other. The Sway Bars will, typically, be installed after the rest of the components are installed.

Hardware Kit#99010062

The StreetGrip Kit is supplied with a hardware kit. This hardware kit contains individual bags for the different kits within the main kit. The bags are labeled to help determine the correct hardware for the installation of the specific kits. The instructions will aid you in selecting the correct hardware for each component. The bags included in this kit are:

Front Sway Bar Kit

Control Arm Kit

Leaf Spring Kit

Front Suspension

The front components that will need to be installed are: Control Arm Bushings, Upper Ball Joints, Shocks, and CoilSprings. The Sway Bar can be installed anytime after the rest of the front suspension is complete.

If you have never done this type of work before, we recommend getting a Factory Service Manual for proper procedures of disassembly and reassembly of the components for your car.

Rear Suspension

The rear components that will be installed are; rear Composite Leaf Springs, Delrin Leaf Spring Bushings, and rear HQ Series Shocks. The Composite Leaf Springs and Delrin Leaf Spring Bushings will be installed at the same time. The Delrin Leaf Spring Bushings are preinstalled in the Leaf Springs.

Alignment Specs

Anytime you change suspension components, you should have the car alignment checked.

Suggested Alignment Specs:

Camber: Street: -.5 degrees

Caster: Street: +3.0 to + 5.0 degrees

Toe: Street: 1/16" to 1/8" toe in



Part # 11179590 - 1970-1981 F-Body Delrin Control Arm Bushings



Recommended Tools



1970-1981 F-Body Delrin Control Arm Bushings

Installation Instructions

Table of contents

Page 5.....	Included Components and Hardware List
Page 6.....	Bushing & Sleeves Deminsions
Page 7.....	70-74 & 75-79 Upper Control Arm Bushings
Page 8.....	80-81 Upper Control Arm Bushings
Page 9.....	70-72 Lower Control Arm Bushings
Page 10.....	73-74 Lower Control Arm Bushings
Page 11.....	75-81 Lower Control Arm Bushings
Page 12.....	Bushing Installation

IF YOUR CAR IS HAS AN OVAL BUSHING IN THE LOWER CONTROL ARM, IT WILL BE NECESSARY TO PURCHASE CONTROL ARMS THAT UTILIZE 2 ROUND BUSHINGS.

Ridetech has a Bushing Removal/Installation tool to help simplify the procedure, #8500009.



Major ComponentsIn the box

Part #	Description	QTY	
70012383	Upper Control Arm Bushing Outer Shell	4	
70012385	Lower Control Arm Bushing Outer Shell	2	
70012386	Lower Control Arm Bushing Outer Shell	2	
70012384	Upper Control Arm Bushing Outer Shell	4	
70012387	Lower Control Arm Bushing Outer Shell	2	
70012420	Delrin Upper Control Arm Bushing - Upper	4	
70012421	Delrin Upper Control Arm Bushing - Upper	2	
70012422	Delrin Upper Control Arm Bushing - Upper	2	
70012423	Delrin Lower Control Arm Bushing - Lower	2	
70012424	Delrin Lower Control Arm Bushing - Lower	2	
70012425	Delrin Lower Control Arm Bushing - Lower	2	
90002522	Upper Bushing Inner Sleeve	4	
90002523	Upper Bushing Inner Sleeve	2	
90000516	Lower Bushing Inner Sleeve	4	
90000517	Lower Bushing Inner Sleeve	4	
90002263	Red Loctite	1	
Part #	Description	Usage	QTY
99501006	1/2"-13 x 3 1/2" Hex Bolt	Lower Control Arm to Frame	4
99502009	1/2"-13 Nylok Nut	Lower Control Arm to Frame	4
99373005	3/8" Split Lockwasher	Upper Control Arm Shaft Bolts	4
99561010	9/16"-12 x 3 1/2" Hex Bolt	Lower Control Arm to Frame	4
99562006	9/16"-12 Nylok Nut	Lower Control Arm to Frame	4

Getting Started.....

The Front Control Arms will need to be removed from the car. Refer to the Factory Service Manual for disassembly procedure.

This F-Body Bushing Kit contains: 3 different size Upper Control Arm Bushing Assemblies and 3 different size Lower Control Arm Bushing Assemblies. If your upper control arm has a Bushing with an outer sleeve that has raised dimples in it to space the bushing out, the new shell doesn't stick out, but does use a Bushing with a THICKER flange. The Outside Diameter of the Bushing, in the area that goes into the Control Arm, is the difference between the 3. Be sure to match the correct diameters with the correct locations. The lowers can have either a 1/2" or 9/16" ID Inner Sleeve. Both are supplied in the kit. The Chart on the next page will assist you in selecting the correct bushings to use. The chart has the deminsions of the shells, bushings and inner sleeves, along with the year ranges they fit. Pages 4-7 contain scale drawings of the bushings and sleeves. Use these pages to help you determine the correct size bushings and quantities for your installation.

MAKE SURE YOU ARE USING THE CORRECT SECTION FOR YOUR CAR'S YEAR.



Bushing & Sleeve Dimensions

OUTER BUSHING SHELLS

QTY	Part #	A	B	C	YEAR FITMENT & QTY USED
UPPER OUTER SHELLS					
4	70012383	1.230	1.313	1.700	70-74 (4), 75-79 (2)
4	70012384	1.230	1.406	1.800	75-79 (2), 80-81 (4)
LOWER OUTER SHELLS					
2	70012385	2.100	1.359	1.800	70-72 (2), 73-74 (2)
2	70012386	2.100	1.656	2.000	70-72(2), 73-74 (2) , 75-79(2), 80-81 (2)
2	70012387	2.100	1.891	2.200	73-74 (2), 75-79 (2), 80-81 (2)

The 73-74 has 2 possibilities for the Front Bushing of the Lower Control Arm. The 2 possibilities are in **BOLD** in the chart.

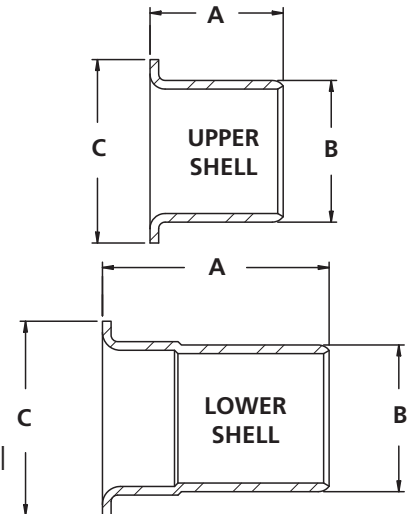

BUSHING DIMENSIONS

QTY	Part #	A	B	C	D	E	YEAR FITMENT & QTY USED
UPPER BUSHINGS							
4	70012420	1.720	.320	1.123	.808	1.610	70-74 (4), 75-79 (2)
2	70012421	1.720	.312	1.213	.808	1.710	80-81 (2)
2	70012422	1.920	.512	1.213	.808	1.690	75-79 (2), 80-81 (2)
LOWER BUSHINGS							
2	70012423	2.330	.172	1.163	.740	1.730	70-72 (2), 73-74 (2)
2	70012424	2.330	.208	1.453	.740	1.850	70-72 (2), 73-74 (2) , 75-79(2), 80-81 (2)
2	70012425	2.330	.180	1.706	.740	2.200	73-74 (2), 75-79 (2), 80-81 (2)

The 73-74 has 2 possibilities for the Front Bushing of the Lower Control Arm. The 2 possibilities are in **BOLD** in the chart.

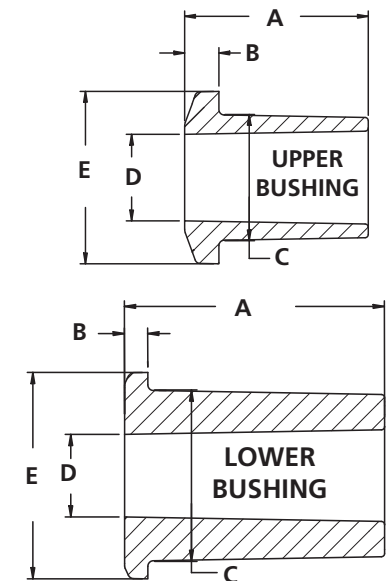

INNER SLEEVES

QTY	Part #	A	B	C	YEAR FITMENT & QTY USED
UPPER INNER SLEEVES					
4	90002522	.818	.688	1.800	70-74 (4), 75-79 (2), 80-81(2)
2	90002523	.818	.688	2.109	75-79 (2), 80-81 (2)
LOWER INNER SLEEVES					
4	90000516	.750	.500	2.375	70-74 (4)
4	90000517	.750	.562	2.375	75-81 (4)





70-74 & 75-79 UPPER DELRIN BUSHINGS

1970-1974 UPPER CONTROL ARM BUSHINGS

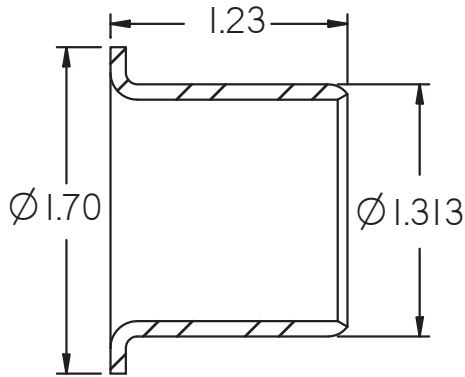

4 X 70012383

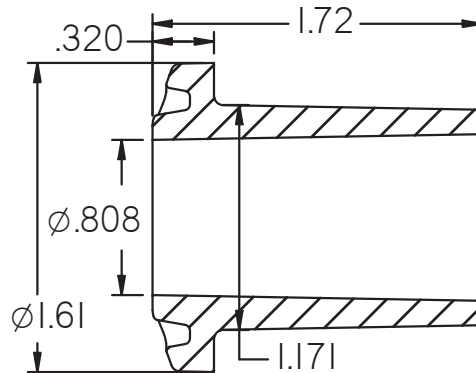

4 X 70012420

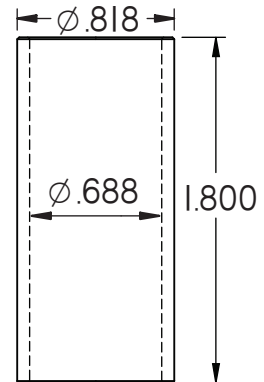

4 X 90002522

1975-1979 UPPER CONTROL ARM BUSHINGS

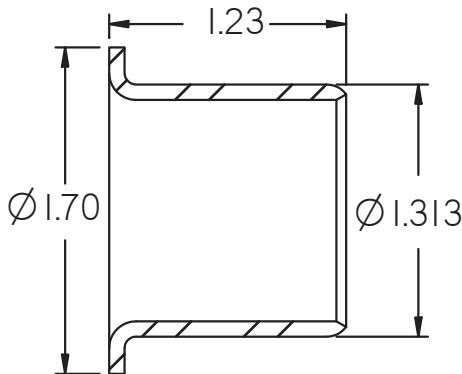

2 X 70012383

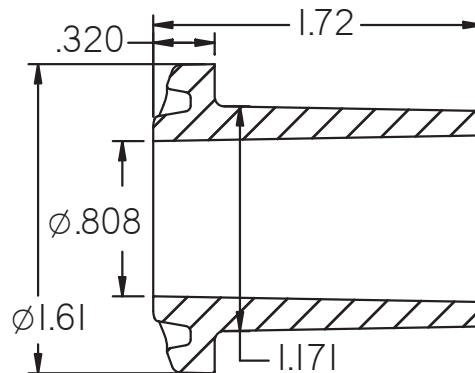

2 X 70012420

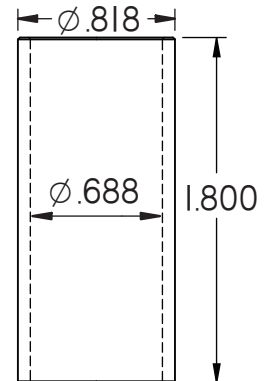

2 X 90002522

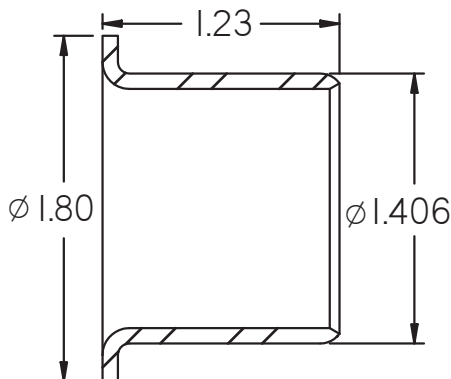

2 X 70012384

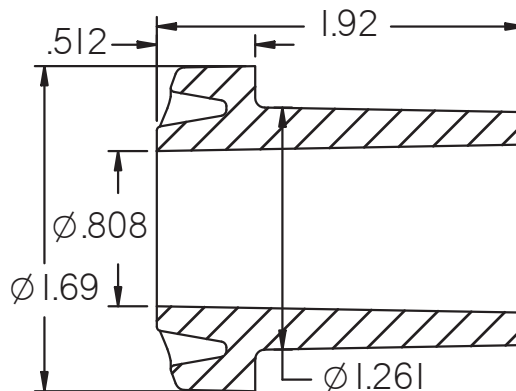

2 X 70012422

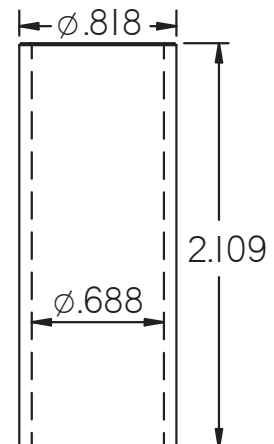

2 X 90002523



80-81 UPPER DELRIN BUSHINGS

1980-1981 UPPER CONTROL ARM BUSHINGS

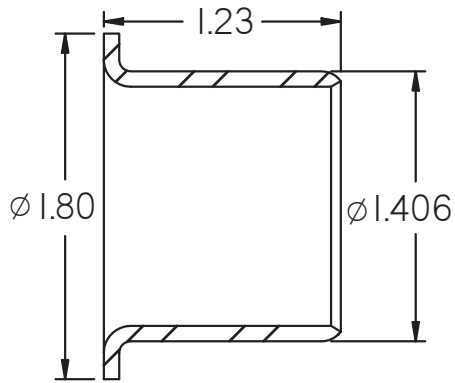

4 X 70012384

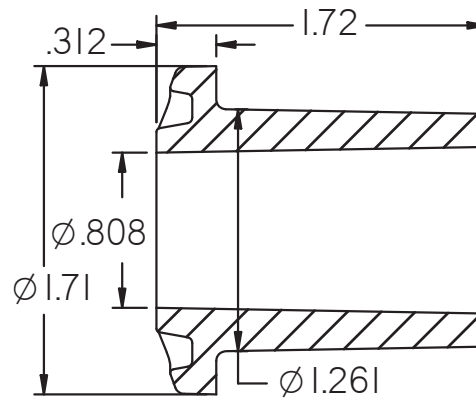

2 X 70012421

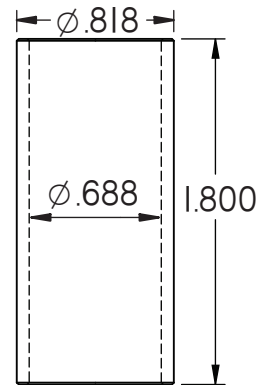

2 X 90002522

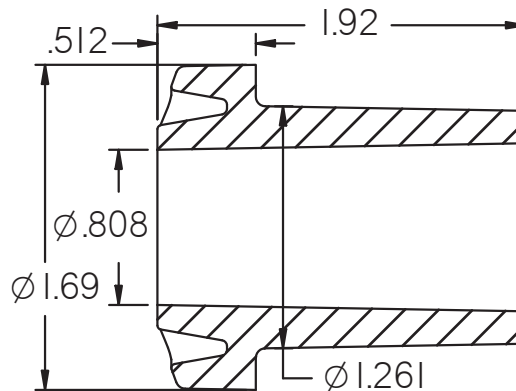

2 X 70012422

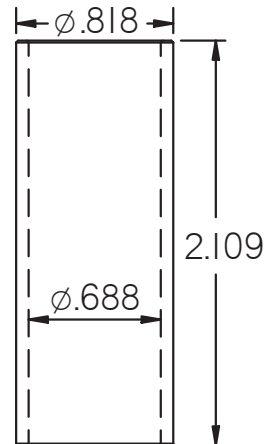

2 X 90002523



70-72 LOWER DELRIN BUSHINGS

1970-1972 LOWER CONTROL ARM BUSHINGS

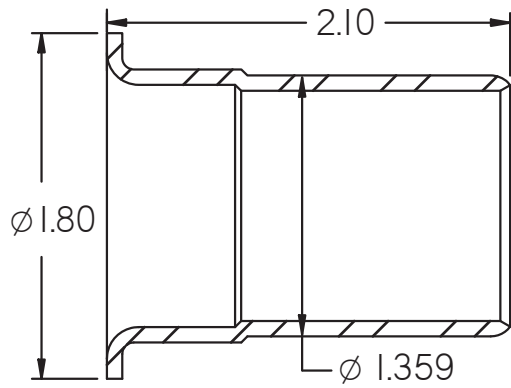

2 X 70012385

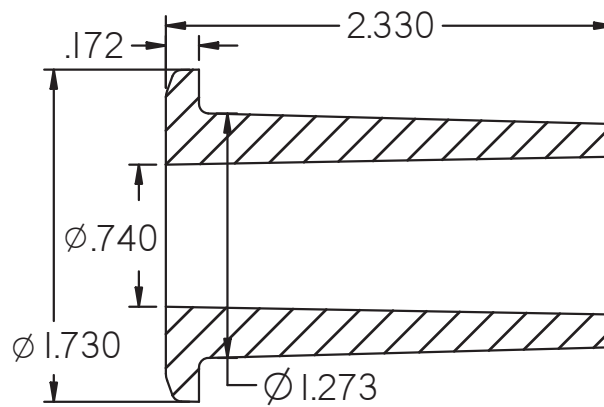

2 X 70012423

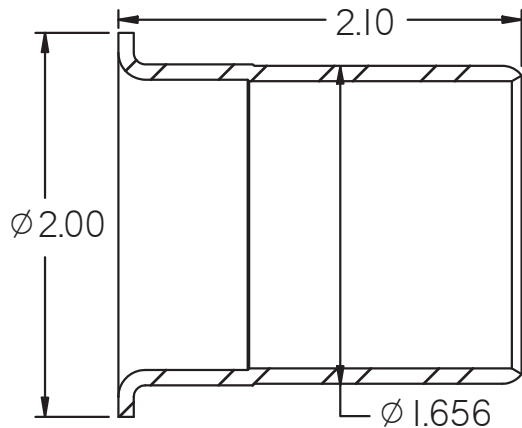

2 X 70012386

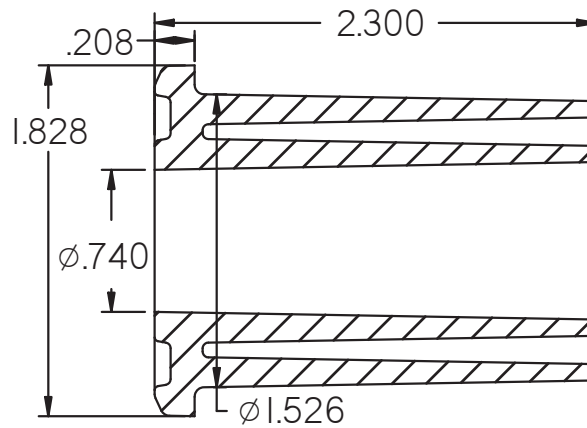

2 X 70012424

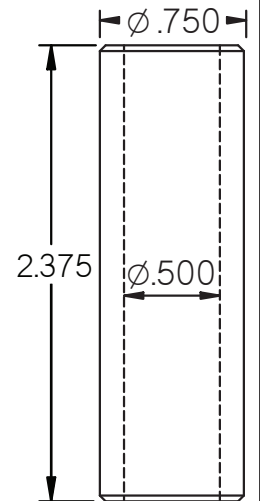

4 X 90000516



73-74 LOWER DELRIN BUSHINGS

1973-1974 LOWER CONTROL ARM BUSHINGS

73-74 can have one of 2 size bushings for the front control arm bushing!

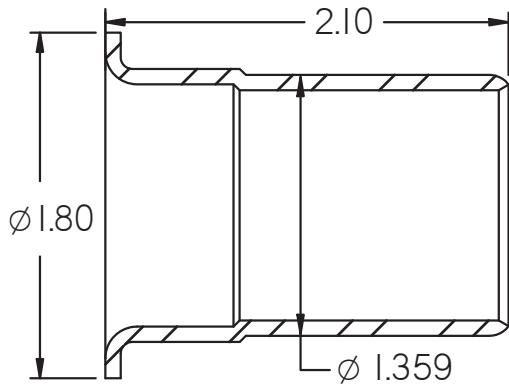

2 X 70012385

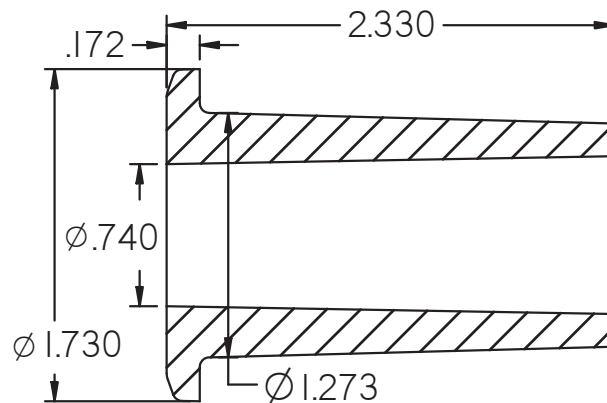

2 X 70012423

OR

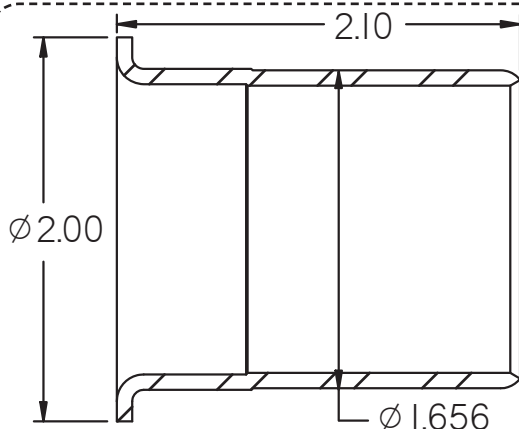

2 X 70012386

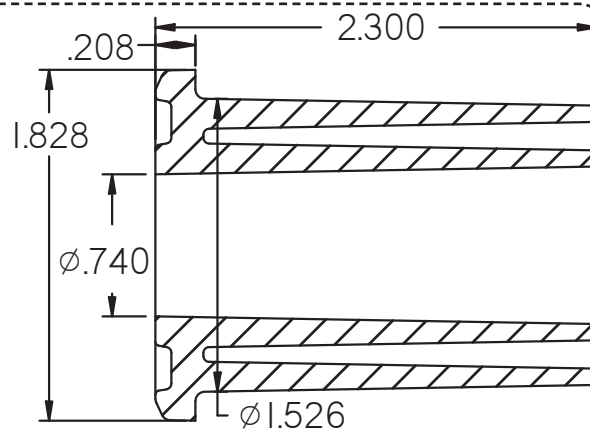

2 X 70012424

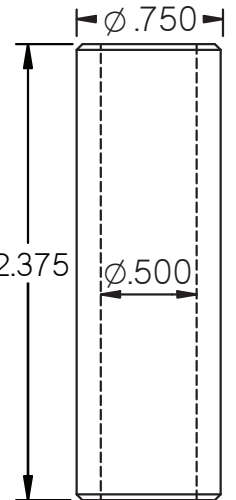

4 X 90000516

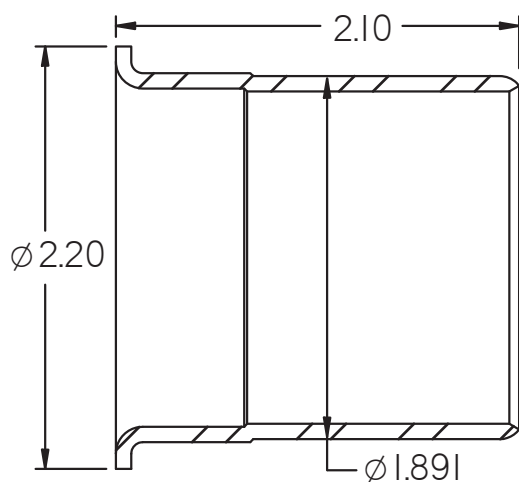

2 X 70012387

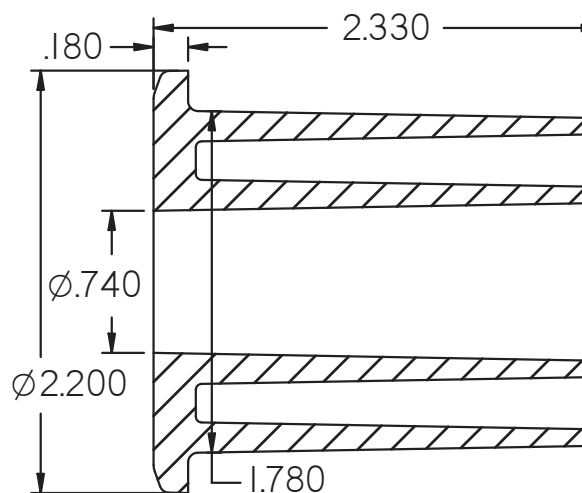

2 X 70012425



75-81 LOWER DELRIN BUSHINGS

1975-1981 LOWER CONTROL ARM BUSHINGS

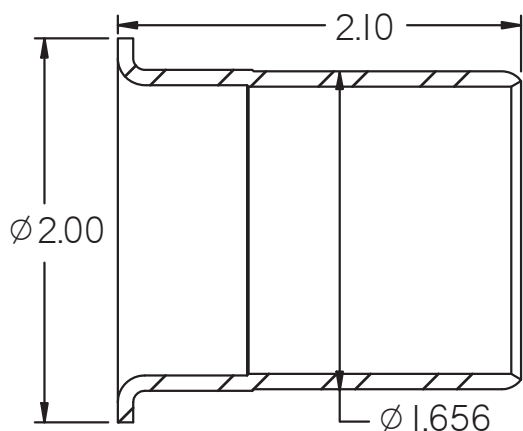

2 X 70012386

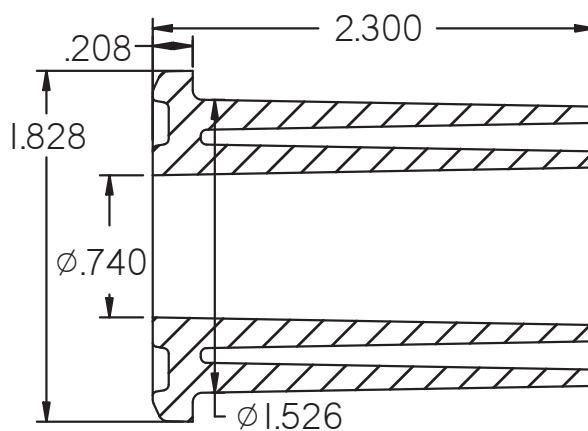

2 X 70012424

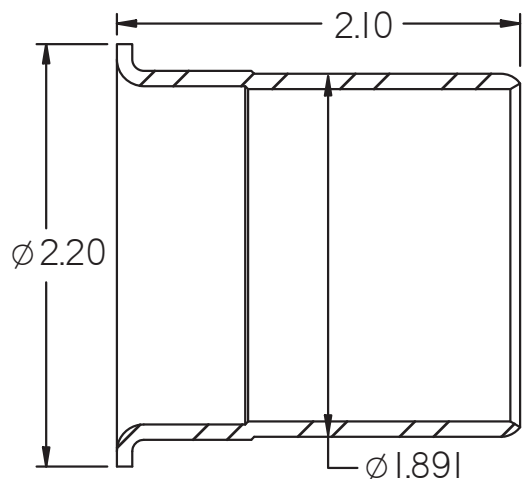

2 X 70012387

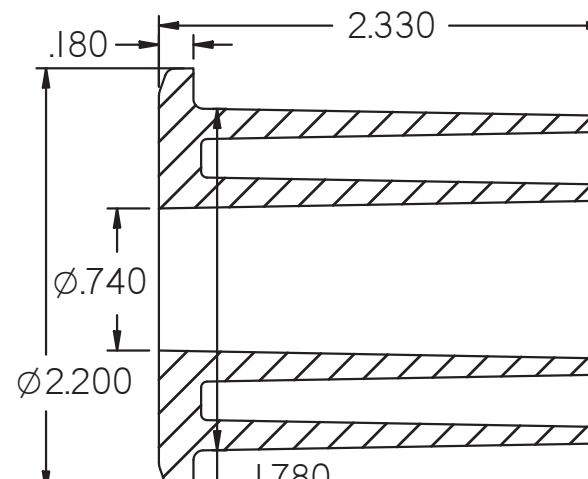

2 X 70012425

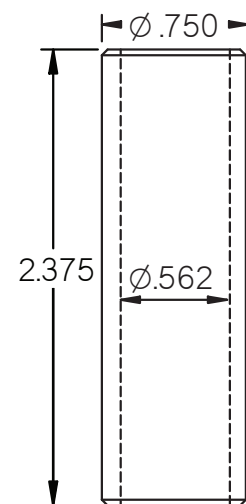

4 X 90000517

Delrin Bushing Installation

There are several different ways that the Bushings can be removed from the Control Arms. If you have an Air Chisel, a Wide Flat Bit works well. If you don't have access to an Air Chisel, they can be removed by first, Drilling out the rubber with a Hand Drill and Drill Bit. With the Rubber removed, distort the Bushing Shell with a Hammer and Chisel and Knock it out. No matter the process used, the main objective is to **NOT** distort the Control Arm.

WE RECOMMEND MARKING DRIVER AND PASSENGER CONTROL ARMS AND CROSS SHAFTS. ALSO, MARK THE ORIENTATION OF THE CROSS SHAFTS.

1. Measure the Outside Width of the Control Arms and write it down before starting Bushing Removal. You will use this Dimension to check the Control Arms after the new Delrin Bushings are installed.



Delrin Bushing Installation

The Cross Shaft must be put in place before installing the Bushing Shells in the Upper Control Arm.

Just like Bushing Removal, there are several ways the Delrin Bushing Assemblies can be installed. No matter the method used, the Control Arm needs to be **SUPPORTED** to keep from distorting the Control Arm. We recommend cutting spacers to go inside the Control Arms when using a Press to install the Bushings. We have used several different methods to install the Bushing Assemblies, we are going to cover the one that worked best for us. When installing the Bushings, the Outer Shell will be installed in the Arm by itself. Next, Press in the Delrin Bushing, followed by the Inner Sleeve. **WE DO NOT RECOMMEND INSTALLING THE BUSHINGS COMPLETELY ASSEMBLED.**

Note: The Delrin is self-lubricating, no lubricant is needed.

Ridetech has a Bushing Removal/Installation tool to help simplify the procedure, #85000009.

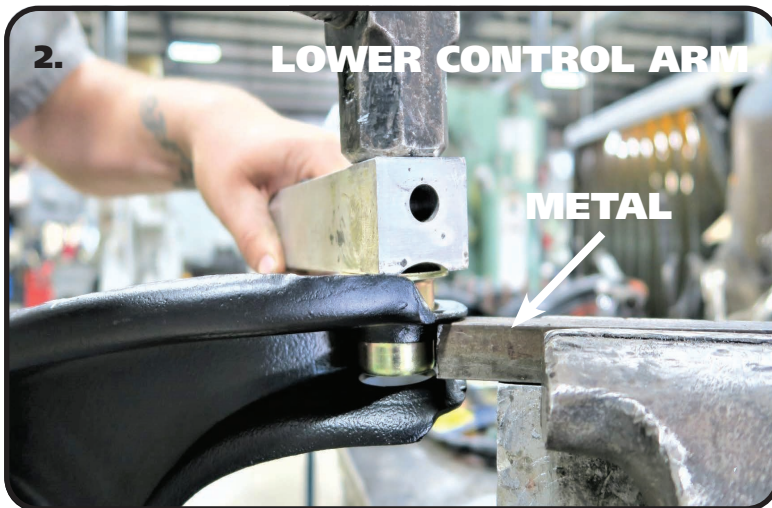

2. Disassemble the Bushing being installed. If installing Bushings in the Upper Control Arm, insert the Cross Shaft before installing any Bushings. Support the Back Side of the Flange the Bushing is being Installed in. Use a STIFF piece of Metal clamped in a Bench Vise for the Lower Control Arms **(Figure 2)**. The Upper Control Arm can be supported by either the same piece of Metal or by the Bench Vise with the Jaws opened wide enough to let the Bushing Shell pass through **(Figure 3)**.



3. Use another Piece of Metal or Strong Wood to Drive the Outer Shell into the Control Arm until the Shell stops against the Control Arm.

4. Press the Delrin Bushing into the Bushing Shell followed by the Inner Sleeve. DO NOT DRIVE IN WITH HAMMER.

5. Reinstall the Outer Washer using the OEM Bolt, but replace the Lockwasher with the supplied Lockwasher. Tighten Hardware to eliminate any gaps between the Bushings and Cross Shaft.

6. Reattach Control Arms to Car. Use the OEM Hardware to attach the Upper and the Supplied 1/2"-13 x 3 1/2" or 9/16"-12 x 3 1/2" Hex Bolts and Nylok Nuts to Install the Lower Control Arms.



Part # 90000913 - GM Tall Upper Ball Joint



Recommended Tools



GM Tall Upper Ball Joint Installation Instructions

Table of contents
Page 14..... Included Components & Ball Joint Installation

DUE TO THE SHANK OF THE BALL JOINT BEING LONGER, THE BALL JOINT BOOT IS DESIGNED TO SEAL ON THE BALL JOINT SHANK. IT DOES NOT SEAL AGAINST THE SPINDLE.



Major ComponentsIn the box

Part #	Description	QTY
90000913	GM Tall Upper Ball Joint	2

Getting Started.....

The Tall Upper Ball Joint is used in the StreetGrip Kit to help correct the Camber Gain. The Camber Gain on the OEM Suspension is incorrect and the Tall Ball Joint repositions the Upper Control to help improve the Camber Gain.

The Upper Ball Joint will need to be disconnected from the Spindle. Refer to the Factory Service Manual for Disassembly.



1. If your Ball Joints are Bolted to the Control Arms, simply unbolt them. If your car has the Original Ball Joints, they will be Riveted to the Control Arms. The Rivets can be removed by Grinding the Heads off and driving the out with a Hammer and Punch.



2. Insert the Ball Joint into the Control Arm from the top side of the Control Arm with the Ball Joint Pin Sticking down. Attach it to the Control Arm with the Hardware Supplied with the Ball Joint. Torque the Hardware to 14 ftlbs. Engage the Ball Joint Pin into the Spindle and install the Castle Nut Supplied. Torque the Castle Nut to 60 ftlbs and tighten to align Cotter Pin Hole. Install Cotter Pin through Hole and Bend Pins to prevent falling out.



Part # 11172350/11172351 - 1970-1981 F-Body Front CoilSpring



Recommended Tools

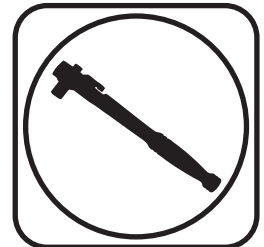

1970-1981 GM F-Body Front CoilSprings Installation Instructions

CoilSpring # 56480700 Small Block /**56538800** Big Block **Installation**

Front dual-rate spring will allow the vehicle to transition small road irregularities via a soft spring rate. When the vehicle compresses the spring far enough (through large bumps or cornering), it transitions to the firmer spring rate to control the bump or body roll. We have worked closely with Hyperco to develop custom dual rates to ensure the best ride possible.

The Front Control Arm Bushings and Upper Ball Joint should be installed before installing spring. The Front Suspension should be assembled with the Lower Ball Joint disconnected from the Spindle.

1. Compress the CoilSpring with an Internal Spring Compressor with the **CLOSE COILS TO THE BOTTOM**.
2. With the OEM Spring Removed, insert the CoilSpring into the Pocket. **SPECIAL ATTENTION NEEDS TO BE PLACED ON THE LOCATION OF THE ENDS OF THE SPRINGS TO MAKE SURE THEY ARE CLOKED CORRECTLY** . The end of the CoilSpring will nest into the receiver area of the Control Arm. If you line up the bottom, the top will be correct.
3. While holding the Spring in place, Slowly Jack the Lower Control Arm up until the Lower Ball Joint can be Engaged into the Spindle. Install the Castle Nut and Torque to 65 ftlbs then tighten as needed to align cotter pin hole. Install Cotter Pin. Once the Ball Joint is tight, remove the Spring Compressor.



Part # 11179120 - 1970-1981 GM F-Body Front Sway

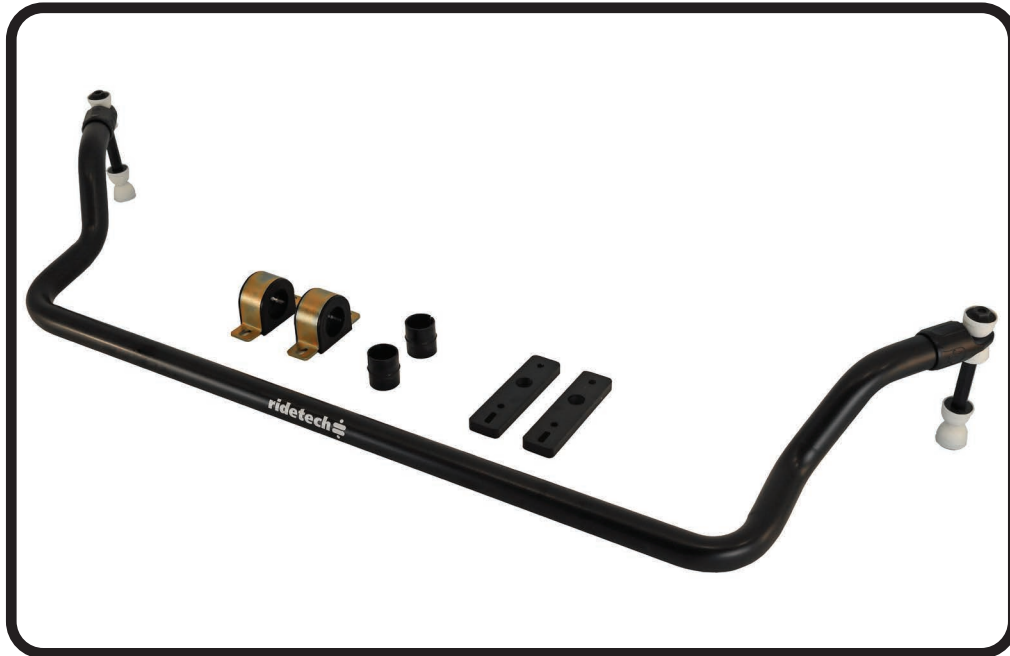

Recommended Tools



1970-1981 GM F-Body Front Sway Bar Installation Instructions

Table of contents

Page 17..... Included Components and Hardware List

Page 18..... Sway Bar Installation

Hardware Torque Specifications

5/16"-16.....	17 ftlbs
3/8"-16.....	30 ftlbs

Major ComponentsIn the box

Part #	Description	QTY
90001226	Front Sway Bar	1
90002933	End Link Kit	1
70012394	Delrin Sway Bar Bushing Liner	2
90002513	Bushing Strap	2
90001099	Sway Bar Bushing	2
90001254	Bushing Mount Adapter	2
90002263	Red Loctite	1

HARDWARE BAGS

QTY	Part Number	Description
ADAPTER PLATE		
2	99371032	3/8"-16 x 1 1/4" Flat Head
2	99311025	5/16"-18 x 1 1/4" Flat Head
2	99371005	3/8"-16 x 1 1/4" Hex Bolt
2	99311011	5/16"-18 x 1 1/4" Hex Bolt
2	99373002	3/8" Flat Washer
2	99313001	5/16" SAE Flat Washer
2	99373006	3/8" Split Lock Washer
2	99313003	5/16" Split Lock Washer
1	90002263	Red Loctite

QTY	Part Number	Description
BUSHING STRAP		
4	99371065	3/8"-16 x 3/4" Hex Bolt
4	99373002	3/8" Flat Washer
4	99373006	3/8" Split Lock Washer

Getting Started.....

This Sway Bar Kit utilizes a Delrin Liner in the Sway Bar Bushing. The Delrin Liner allows the Sway Bar to move freely and quietly in the Bushing. The Delrin is self-lubricating, no lubrication is required.

Note: The threaded holes in the frame can be either 5/16"-18 or 3/8"-16. Hardware is supplied for both.

1. Jack the vehicle up to a safe working height and support with jack stands. Make sure the jack stands are stable before working under the car.
2. Remove the stock sway bar.
3. After removing the stock sway bar, determine what size hardware the frame will require.



4. Open the Delrin Liner at the split and slip it over the Sway Bar. Position it in the area that the bushing will ride based on the location of the stock swaybar. Do this on both ends of the swaybar.



5. Open the Sway Bar Bushing at the split and slide it **OVER** the Delrin Liner. Do this on both Delrin Liners.



6. Slip the Bushing Straps over the SwayBar Bushings. **Before continuing to the next step, determine the bolt size required for your installation. The threaded holes in the frame can be either 5/16"-18 or 3/8"-16. Hardware is supplied for both.**

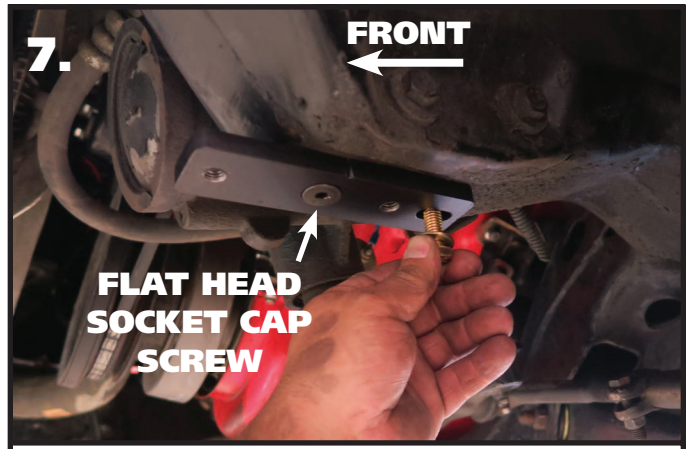

7. Hold the Frame Plate up to the OEM holes, the Counter Sunk hole will be positioned over the front hole with the slot to the rear. Apply Red Loctite to the Flat Head Bolt. The rear 1 1/4" long bolt uses a Split Washer and Flat Washer. Torque Hardware.



8. Slide the Sway Bar into position on the car with the Sway Bar arms above the tie rods. Install a 3/8" Lock Washer & 3/8" Flat Washer on the 3/8"x 3/4" Hex Bolts. Do **NOT** Complete tighten the Hardware, it will be left partially loose until the End Links are installed.

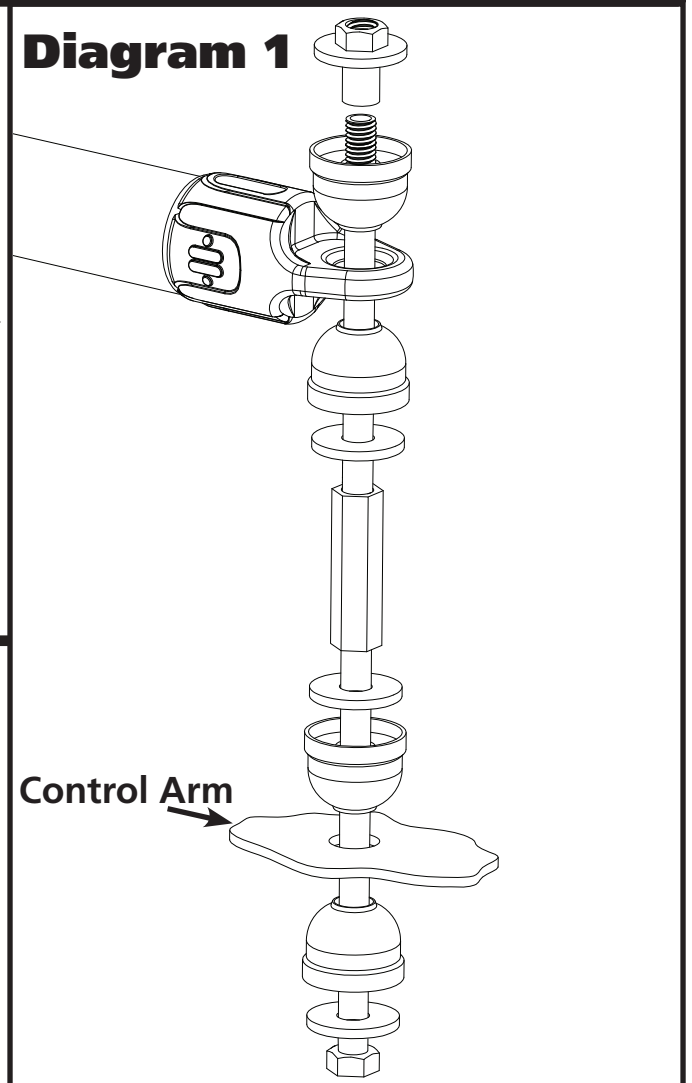

9. Install the End Links using **Diagram 1** as a reference. Install both end links before tightening the end link hardware. Tighten the end link barrel nut until it is flush with the end of the bolt, and then tighten it 2 more complete rounds.

10. Torque the Sway Bar mounting hardware to 30 ftlbs.



Part # 11174799 - 1970-1981 F-Body Composite Leaf Springs

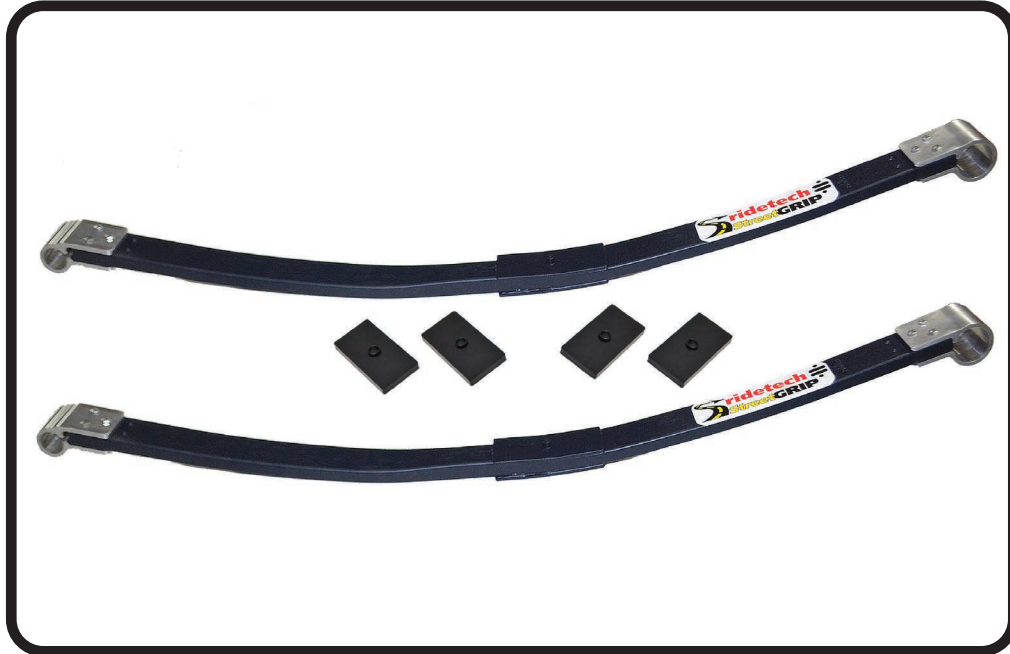

Recommended Tools



1970-1981 F-Body Composite Leaf Springs Installation Instructions

Table of contents	
Page 20.....	Included Components and Hardware List
Page 20-23.....	Leaf Spring Installation

IT IS VERY IMPORTANT THAT NOTHING COMES IN CONTACT WITH THE COMPOSITE LEAF SPRINGS.

THESE COMPOSITE LEAF SPRINGS WILL ACCEPT OEM LEAF SPRING BUSHINGS. THE RIDETECH STREETGRIP KIT HAS THE DELRIN LEAF SPRING BUSHINGS (11165399) PREINSTALLED FOR MAXIMUM PERFORMANCE.



Major ComponentsIn the box

Part #	Description	QTY
90002907	Leaf Spring Blade Assembly w/70012426, 70012427, & 90000526 installed	2
90002498	Upper Leaf Spring Clamping Plates	2
90002499	Lower Leaf Spring Clamping Plate	2
70012428	Delrin Rear Shackle Frame Bushing	4
90000526	Inner Bushing Sleeve	2
90002496	Shackle Plate	4
99371050	3/8"-16 x 1 1/2" Conical Bolt	6
99372009	3/8"-16 U-Nut	6

Hardware Bag - Leaf Spring Kit

99501035	1/2"-13 x 5" Hex Bolt	6
99502009	1/2"-13 Nylok Nut	6

Getting Started.....

IT IS VERY IMPORTANT THAT NOTHING COMES IN CONTACT WITH THE LEAF SPRING.

1. Jack the car up and support it by the frame rails. You will need to raise and lower the rear differential with a jack to ease installation. With the car supported by the frame, put the jack underneath the rear end housing and raise the jack up just enough to support the differential. Disconnect the bottom of the shock and remove the rear leaf springs. Retain the OEM hardware. The OEM frame bushings will need to be removed and all debris removed from the holes to ease installation of the bushings.
2. The Shackle Plates and Hardware can be used to push the rear bushings into the frame location. Start the bushings into the frame and insert a 1/2"-13 bolt into a shackle plate. Insert the bolt/shackle plate into the bushing and install a second shackle plate on the bolt sticking through the bushing. Install a 1/2"-13 nut and tighten until the bushings bottom out on the frame. Remove the shackle plates and install the inner sleeve.

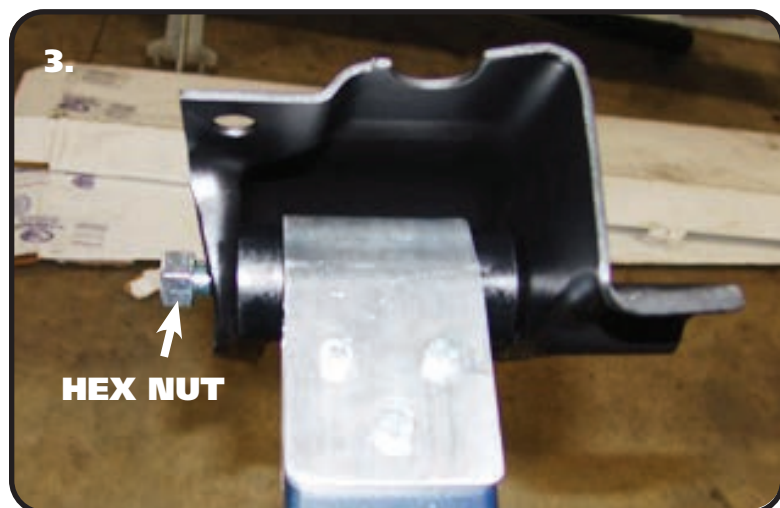

3. Bolt the **LARGE BUSHING END** of the Composite Leaf Spring into the OEM front leaf spring mount using a 1/2"-13 x 5" Hex Bolt and 1/2"-13 Nylok Nut. The Bolt must be installed with the threads pointing to the **OUT-SIDE** of the car. Diagram #4 is the correct.

NOTE: Front spring pocket must be removed from car before installing new springs. New Hardware is supplied in kit.



Leaf Spring Installation

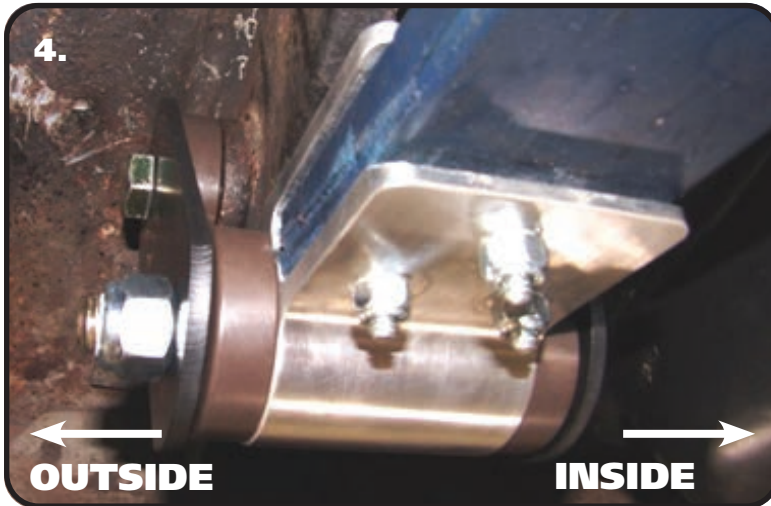

4. Attach the rear of the Composite Leaf Spring to the rear mount. If you are using the Ridetech Delrin Bushings, new Shackles and Hardware is supplied with them. Attach a Shackle Plate to each side of the Frame Bushing using a 1/2"-13 x 5" Bolt (WITH THREADS POINTING TO INSIDE OF CAR) and 1/2"-13 Nylok Nut. Do not tighten. Align the remaining bolt holes in the shackle plates with the sleeve in the rear Leaf Spring bushing. Install a 1/2"-13 x 5" Bolt (WITH THREADS POINTING TO OUTSIDE OF CAR) and 1/2"-13 Nylok Nut. Do Not tighten hardware, it will get tightened later.



5. Swing the Leaf Spring up and attached the front mount to the car using the supplied 3/8"-16 x 1 1/2" Conical Body Bolts and U-Nuts. Tighten Hardware
Note: You may have to jack the rear differential up enough to swing the leaf spring in place.

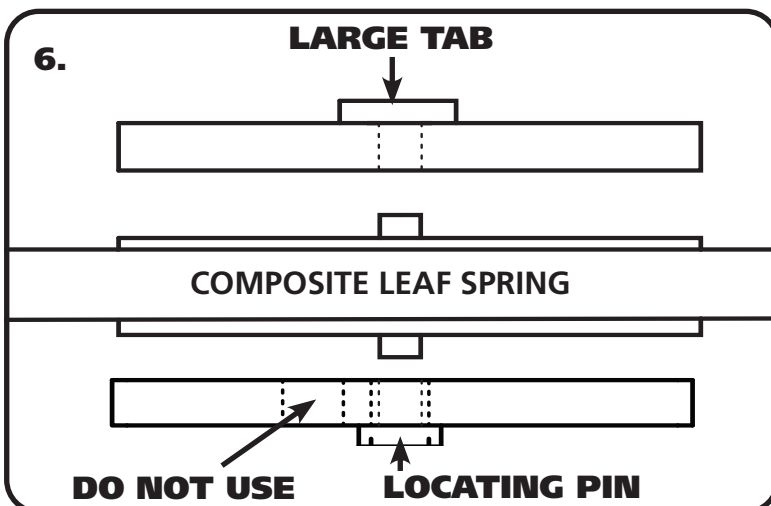

6. The Composite Leaf Spring has to be clamped in place with the OEM lower plate. A new Lower Plate is supplied, if you are also installing Ridetech Shocks. The composite leaf spring requires a Clamping Plate on the top and bottom of the leaf spring. The TOP clamping plate has a LARGE TAB attached to the top of it. The BOTTOM clamping plate has a LOCATING PIN on the bottom of it. **The top and bottom leaf spring locating pins need to be inserted into the holes in the Clamping Plates on the FLAT SIDE.** The tab on the top clamping plate will nest in the leaf spring mount. The bottom clamping plate pin will need to be inserted into the hole in the lower plate to correctly position the rear differential.

NOTE: The rear hole of the bottom plate is NOT used.



Clamping Plate & Stud Installation

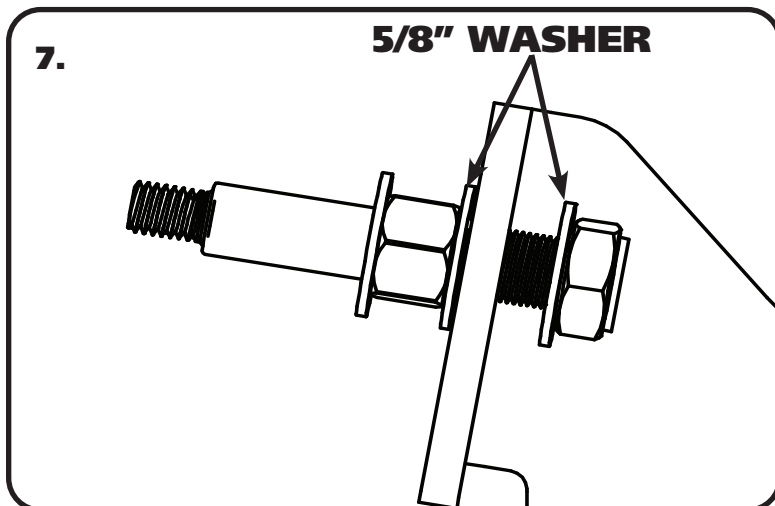

7. We recommend installing the Shock Studs in the Leaf Spring Clamping Plate before installing the plates in the car. The Shock Studs are supplied in the kit. Refer to **Images 7-9** for proper installation. The shock stud hardware is packaged with the stud. Install a 5/8" washer onto the 5/8" threads. Insert the stud into the hole on the plate. Install a washer on the threads, followed by a 5/8"-18 Locknut. Tighten 5/8" Nut.



8. The OEM leaf spring clamping plate will be replaced with the clamping plate supplied in the kit. Retain the OEM Hardware when removing clamping plate. The driver and passenger sides use the same plate. When installing each plate, the shock mounting location needs to be in the proper location. The driver side shock mount is to the rear of the car, on the wheel side of the spring. Passenger shock mount is to the front of the car, on the wheel side of the spring. Diagram "7" & "8" show the Driver clamping plate installed.

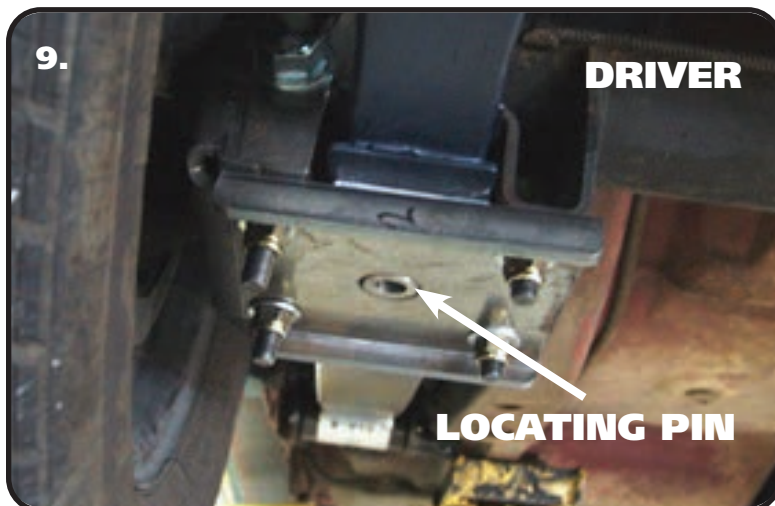

9. Lower the differential onto the Leaf Spring with the top Clamping Plate in place like shown in Diagram "6". The TAB on the Top Clamping Plate will nest in the NEW leaf spring mount. Install the lower Clamping Plate followed by the NEW lower mount **being sure the Pins and Holes are aligned**. Install the OEM hardware. Evenly tighten the hardware in a crisscross fashion. Torque the nuts to 55 ftlbs.



Leaf Spring Installation

Note: When tightening the mounts, pay attention to the pads on the springs to make sure there is visible compression of the pads. .030"-.060" of compression is needed for the springs to be securely mounted. All of the clamping force needs to be on the spring itself.

10. Tighten the Bushing hardware, torquing it to 75 ftlbs. The Delrin Bushings will not bind, so it isn't necessary to have the car at ride height. If using OEM style rubber bushings, the car will need to be on the ground at ride height before tighten the bushing hardware.

11. Install the Ridetech HQ Series shocks. Refer to the shock instructions.

12. DOUBLE CHECK TO MAKE SURE NOTHING IS COMING INTO CONTACT WITH THE LEAF SPRING.

Front & Rear HQ Series Shocks



Recommended Tools

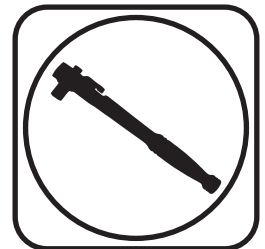

Front & Rear HQ Series Installation Instructions

Table of contents

Page	24.....	Rear Shock Installation
Page	25.....	Front Shock Installation
Page	26.....	Front Shock Installation & Adjustment



Rear - Part # 22199847 - 7.55" HQ Series Shocks

Major ComponentsIn the box

Part #	Description	QTY
986-10-020	7.55" Stroke Shock	2
90002510	Leaf Spring Clamp Plate	2
90002068	Extended Trunnion	2
90002103	5/8" ID Shock Sleeve (Installed in Shock)	2
90001617	Shock Stud	2
70011139	5/8" ID Shock Bushing	2
70011138	3/4" ID Shock Bushing	2
99311001	5/16"-1 x 1" Hex Bolt	4
99313001	5/16" Flat Washer	4
99313003	5/16" Lock Washer	4

Shock Installation

The Rear Shocks should be installed in conjunction with the Rear Leaf Springs.

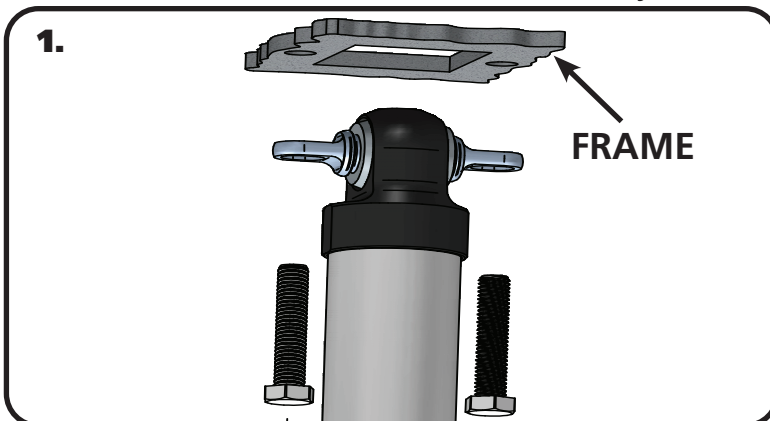

1. With the OEM Shock removed and the NEW lower mounted installed (Refer to leaf spring installation), install the Ridetech Shock. Attach the top of the Shock in the OEM Location using the supplied 5/16" Hardware. Install a 5/16" Lock Washer followed by a 5/16" Flat Washer on each of (4) 5/16"-18 x 1" Hex Bolts. This Hardware will be inserted into the holes in the Shock Trunnion to attach the shocks in the OEM Location. It may be necessary to rotate the Trunnion to get it in the correct position. This can be done by sticking a screwdriver in one of the slots and spinning the trunnion in the shock bushing.

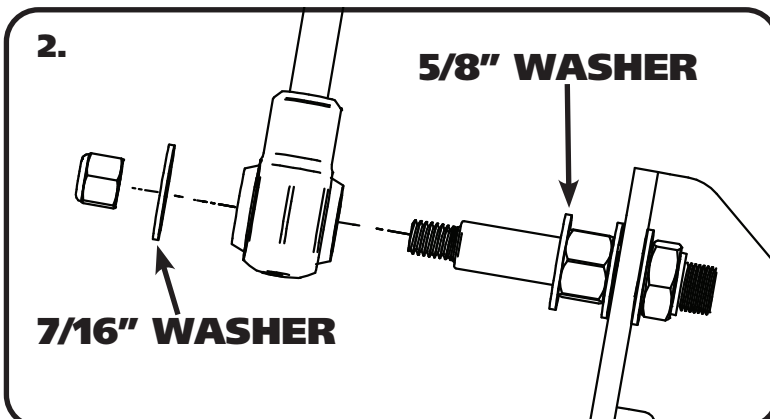

2. Install a 5/8" washer on the shock stud. Slide the shock onto the stud. It may be necessary to raise the differential to get the shock on the stud. With the shock on the stud, install a 7/16" Flat Washer followed with a 7/16"-20 nylok nut. Tighten nylok nut.



Front- Part #22159847 - 5.25" Stroke HQ Series Shocks

Major ComponentsIn the box

Part #	Description	QTY
986-10-043	5.25" Stroke Shock	2
70011139	5/8" ID Shock Bushing (Installed in Shock)	2
90002068	Wide Trunnion (Installed in Shock)	2
70011141	Bushing Support Washer	4
70011140	Stem Bushing	4
99372006	3/8"-24 Thin Jam Nut	4
99311001	5/16"-1x 1" Hex Bolt	4
99313001	5/16" Flat Washer	4
99313003	5/16" Lock Washer	4

Due to manufacturing tolerances it may be necessary to clearance the Control Arm to get the Shock through the Control Arm opening.

Shock Installation

Before installing the Shocks, the Control Arm Bushings, Upper Ball Joint, and CoilSprings should be installed.

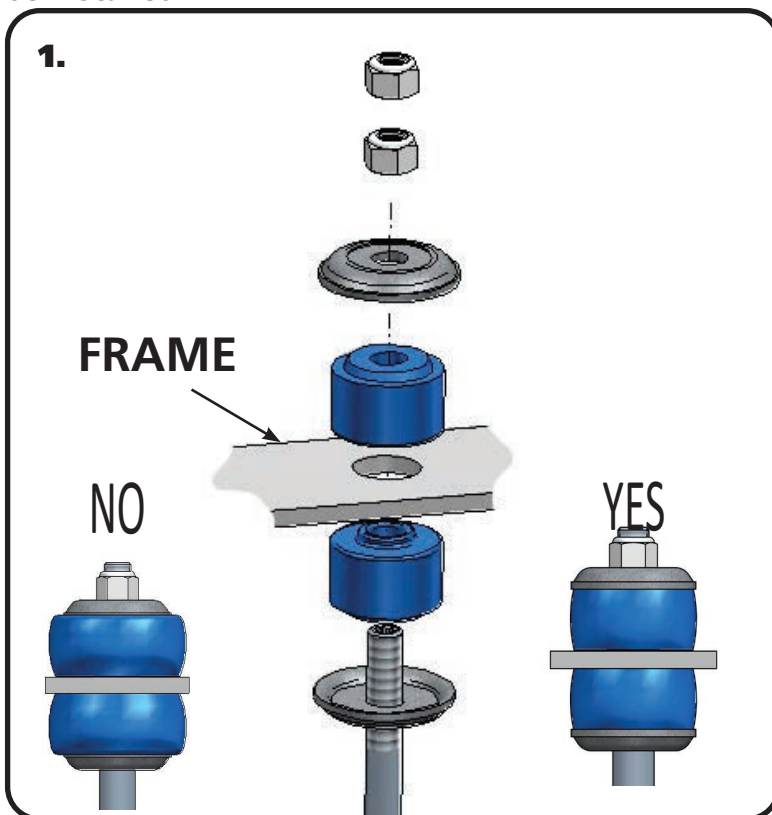

1. With the OEM shock removed, install the Ridetech shock. Remove the adjuster knob by loosening the set screw using the supplied Hex Key. Install a Bushing Support Washer on to the shock shaft followed by a Shock Stem Bushing. Insert the assembly through the factory shock hole in the frame. With the shock stud sticking through the frame, install a Shock Stem Bushing on to the shock stud followed with a Bushing Support Washer. Install a 3/8"-24 Thin Jam nut onto the threads and tighten to 35 inlbs. The Bushing should be tight, but not to the point that the bushing is bulging past the Support Washer. Install the 2nd 3/8-24 Thin Jam nut and tighten it against the first nut. Reinstall the Adjuster Knob, align the set screw with the FLAT side of the adjuster shaft that is sticking out of the top of the shock shaft.

NOTE: It may be necessary to remove the OEM Speed Nuts from the Control Arm to allow room for the Shock to slide through the opening in the Control Arm. The Speed Nuts can be reinstalled after the Shock is in position.



Shock Installation and Adjustment

2.

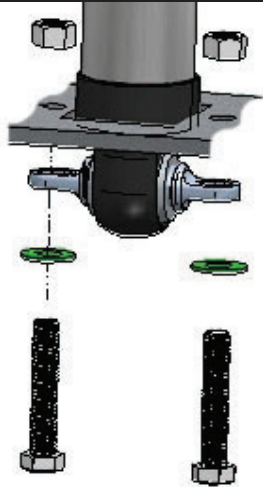

2. Attach the Trunnion to the OEM Control arm using the supplied 5/16" Hardware. Install a 5/16" Lock Washer followed by a 5/16" Flat Washer on each of (4) 5/16"-18 x 1" Hex Bolts. This Hardware will be inserted into the holes in the Shock Trunnion to attach the shocks in the OEM Location. It may be necessary to rotate the Trunnion to get it in the correct position. This can be done by sticking a screwdriver in one of the slots and spinning the trunnion in the shock bushing.

Shock adjustment 101- Single Adjustable

Rebound Adjustment:

How to adjust your new shocks

The rebound adjustment knob is located on the top of the shock absorber protruding from the eyelet or stud top. You must first begin at the ZERO setting, then set the shock to a street setting of 12 or handling setting of 8.



-Begin with the shocks adjusted to the ZERO rebound position (full stiff). Do this by rotating the rebound adjuster knob clockwise until it stops.

-Now turn the rebound adjuster knob counter clockwise 12 clicks. This sets the shock at 12 for a street setting. If you are after a handling setting only go 8 clicks.

Take the vehicle for a test drive.



-if you are satisfied with the ride quality, do not do anything, you are set!

-if the vehicle is too soft increase the damping effect by rotating the rebound knob clockwise 3 additional clicks.

-if the vehicle is too stiff rotate the rebound adjustment knob counter clock wise 2 clicks and you are set!

Take the vehicle for another test drive and repeat the above steps until the ride quality is satisfactory.

Note:

One end of the vehicle will likely reach the desired setting before the other end. If this happens stop adjusting the satisfied end and keep adjusting the unsatisfied end until the overall ride quality is satisfactory.