

Specifications

Part #:	54900	54901	54902	54903	54900U	54901U	54902U	54903U	54904	54905
Deck Height:	9.750"	9.750"	9.240"	9.240"	9.750"	9.750"	9.240"	9.240"	9.760"	9.250"
Bore Size:	4.165"	4.125"	4.165"	4.125"	4.160"	4.120"	4.160"	4.120"	4.100"	4.100"
Bore Finish:	Honed	Honed	Honed	Honed	Bored	Bored	Bored	Bored	Bored	Bored
Liner Length:	6.38"	6.38"	5.87"	5.87"	6.38"	6.38"	5.87"	5.87"	6.38"	5.87"
Cyl. Wall Thickness:	.070"	.090"	.070"	.090"	.0725"	.925"	.0725"	.925"	.1025"	.1025"
Weight:	120 lbs.	124 lbs.	111 lbs.	115 lbs.	120 lbs.	124 lbs.	120 lbs.	115 lbs.	125 lbs.	116 lbs.
Deck Thickness:	.750"	.750"	.500"	.500"	.750"	.750"	.500"	.500"	.760"	.510"

See Illustration A for deck height measurements.

Material:	A357-T6 Aluminum
Liner O.D.:	4.305"
Parent Bore Thickness:	.200"
Stroke:	Tall Deck – 4.600" (may require final notching of liners for rod clearance) Standard Deck – 4.250" (may require final notching of liners for rod clearance)
Camshaft Position:	Raised .388"/9.86mm (requires 2 extra links in timing chain)
Cam Thrust Plate:	RHS #549102 included with block
Rear Cover:	RHS #549101 included with block
Cam Bearing:	Durabond Babbit Bearing – installed and microfinished for 55mm cam
Lifter Bores:	Machined for .842" lifter (material to accommodate 1.060" bushing for key lifter)
Lifers Style:	Requires tie bar style lifer (will not accommodate OE trays)
Main Bearing Bore:	2.751" +/- .0003" (69.88 mm +/- .009)
Main Caps:	8620 Billet
Main Studs:	ARP 2000 7/16"-20 x 5.150" x 7/16"-14
Main Bolts:	ARP 8740 3/8"-16 x 1.250"
Oil System:	Priority Main Oiling with -12 AN provisions front and rear
Oil Pan:	Stock bolt pattern, pan will depend on stroke/rod clearance requirements
	See Illustration B.
Head Studs:	6-Bolt LSX Pattern
Freeze Plugs:	Threaded -12 AN (included with block)

Features

- Standard and 9.750" Tall Deck
- Long Arm Friendly – Engineered to Clear 4.600" Stroke with 2.100" Rod Pin and 60mm Cam
- Priority Main Oiling – Dry Sump Friendly, Front & Rear -12 AN Fittings Feeds and OEM Feed
- Raised Cam Centerline – Accommodates Up to a 60mm Cam with 4.600" stroke
- 6-Head Bolt Design with Full Water Jacket Around Cylinders
- Chilled Main Bearing Bulkheads
- Improved Bay-to-Bay Breathing

Tech Notes

Heads:	Any LS head with stock or GM LSX 6 bolt pattern
Crankshaft:	4.600" Stroke should have 3.52" cheek radius max.
Cranks Sensor:	Stock Gen III/Gen IV depending on controller (will require plugging if not used)
Cam Sensor:	<u>All blocks are machined for Gen III cam sensors.</u> However, the standard deck blocks will require a spacer to accommodate the raised cam; tall deck is a drop-in application. Gen IV will require modifying the front cover to reposition the sensor for the raised cam.

Tech Notes Cont.

Knock Sensor:	Machined for Gen III & Gen IV knock sensors
Valley Cover:	Gen II or Gen IV valley cover
Front Cover:	Gen III & Gen IV covers will fit. Gen IV-style cover will require modification of cam sensor location to accommodate the raised cam. (Aftermarket and distributor drive covers will require modification for raised cam.)
Timing Chain & Sprockets:	Raised cam will require chain with 2 extra links. Single roller will clear front cover, oil pump and the block. Double roller will require spacing of oil pump and checking clearance of the front cover. Specific timing sets available from COMP Cams.
Valve Train:	Utilize valve train for selected heads with pushrod length sized accordingly for raised cam
Lifters:	Requires revised dog bone or tie bar lifter design (stock lifter trays will not work)
Water Pump:	Utilizes stock LS water pump
Windage Tray:	Long stroke may require shimming of windage tray
Piston Oil Squirter:	Priority Main oiling system requires only 4 piston squirters with cross over design. Threaded to work with LS9 check flow through bolt, body and nozzle will need to be fabricated by engine builder to ensure proper clearance to the rotating assembly. Oil hole provision is only a pilot hole and will require drilling into oil galley to activate.
Engine Mounts:	Machined for Gen III & front engine mounts, provisions for Gen 1 mounts are spot drilled and will require drill and tapping and may break into waterjacket. In the event that these holes break into the water jacket, apply sealant to these fasteners. We also recommend installing a flush stud into the Gen III hole adjacent to the Gen 1. Hold to add backup for the bolt. Also provisions for front motorplate race mounts. See Illustration C.
Block Heater:	The factory block heater will not thread into the hole in the stock location. Modifications will need to be made to thread into the -12AN hole.
Oil Dipstick:	Provision for stock oil dipstick, this hole will require plugging if not used.
Oil System:	The RHS priority main oiling system has eliminated the stock "barbell plug" and replaced it with a stepped 1/2"-3/8" NPT plug design to eliminate the restriction created by the "barbell" body using the external -12 feed. See Illustrations D & E.
Oil Pressure Sensor:	The RHS block is designed to use the Gen IV oil sensor, if using a Gen III cover and the GM or equivalent screw in oil pressure sensor you will need to drill and tap the block. Maximum recommended sensor size is M16 or 3/8 NPT. See Illustration F
Torque Specifications:	
Main Studs:	95 ft./lbs. Utilizing ARP Ultra Torque Lube (129 Nm)
Main Cross Bolts:	35 ft./lbs. Utilizing ARP Ultra Torque Lube (48 Nm)
Cam Thrust Plate:	18 ft./lbs. (25 Nm)
Rear Cover:	18 ft./lbs. (25 Nm)
Head Stud Torque:	Use fastner manufacturer recommended installation, sequence and torque.



LS Race Block

Suggested Components

Part Type	Brand/Part #	Description
Torque Plate Set:	RHS #549150	LS Torque Plate Set
Main Cap Puller:	RHS #549106	LS Engine Main Cap Puller
Head Gasket:	RHS #549400-L	RHS LS Head Gasket 4.00" Bore-Left
	RHS #549400-R	RHS LS Head Gasket 4.00" Bore-Right
	RHS #549401-L	RHS LS Head Gasket 4.165" Bore-Left
	RHS #549401-R	RHS LS Head Gasket 4.165" Bore-Right
	RHS #549402-L	RHS LS Head Gasket 4.200" Bore-Left
	RHS #549402-R	RHS LS Head Gasket 4.200" Bore-Right
		See Illustration G.
Timing Set:	RHS #3154	COMP Cams Double Roller Timing Chain Set
	RHS #3173KT	COMP Cams Double Roller Adjustable Timing Chain Set
	RHS#9302	RHS Single Row Replacement Timing Chain (chain only)
	RHS#9132	RHS Double Row Replacement Timing Chain (chain only)
Lifters:	COMP #15956-16	.842" Short Travel Hydraulic Lifter (captured link bar)
	COMP #8956-16	.842" Endure-X Mechanical Roller (drop off link bar type)
	COMP #98956-16	.842" Elite Race Mechanical Roller (captured link bar type)
	COMP #98954-16	.875" Elite Race Mechanical Roller (captured link bar type)
	COMP #98952-16	.904" Elite Race Mechanical Roller (captured link bar type)
Assembly Lube:	COMP #102	COMP Engine Assembly Lube 4 oz. jar
	COMP #104	COMP Engine Assembly Lube 8oz. Jar
	COMP #127	COMP Engine Assembly Lube 16 oz. Tube
	COMP #100-9908	ARP Ultra Lube Torque Lube .5 oz.
Intake Spacer	RHS #549107	LS1 Intake Spacer Kit for 9.750" Deck
Plates:	RHS #549108	LS3 Intake Spacer Kit for 9.750" Deck
	RHS #549109	LS7 Intake Spacer Kit for 9.750" Deck

Service Items

Part Type	Brand/Part #	Description
Liners:	RHS #54901CL	4.040" Bore Tall Deck Outer Right Liner (Cylinders #2 & #7)
	RHS #54904CL	4.040" Bore Tall Deck Outer Left Liner (Cylinders #1 & #8)
	RHS #54900CL	4.040" Bore Tall Deck Inner Liner
	RHS #54903CL	4.040" Bore Standard Deck Outer Right Liner (Cylinders #2 & #7)
	RHS #54905CL	4.040" Bore Standard Deck Outer Left Liner (Cylinders #1 & #8)
	RHS #54902CL	4.040" Bore Standard Deck Inner Liner
	RHS #54906CLSB	3.840" Bore Standard Deck Outer Right Liner (Cylinders #2 & #7)
	RHS #54907CLSB	3.840" Bore Standard Deck Outer Left Liner (Cylinders #1 & #8)
	RHS #54902CLSB	3.840" Bore Standard Deck Inner Liner
Rear Cover:	RHS #549101	Rear Cover Seal & Fasteners
Cam Thrust	RHS #549102	Brass Cam Thrust Plate 6 Bolts
Plate:	RHS #549204-1	Thrust Plate O-Ring
Cam Bearings:	RHS #549202-1	Replacement Cam Bearing-Finished I.D.
Main Caps:	RHS #549100-1	8620 Billet Main Cap
Main Dowel :	RHS #549201-1	Main Dowel Pin

Service Items Cont.

Part Type	Brand/Part #	Description
Main Studs:	RHS #549300-1	Main Cap Stud, Long
	RHS #549301-1	Main Cap Stud, Short
	RHS #549302-1	Main Cap Side Bolt
	RHS #549303-1	Main Cap 12pt Nut
	RHS #549304-1	Main Cap Washer
	RHS #549305-1	Main Cap Side Washer
Transmission	RHS #549205-1	Block-To-Transmission Dowel Pin
Dowels:		
Freeze Plugs:	RHS #549203-1	Threaded -12 AN Plug
	RHS #549203-1	O-Ring

RHS™

Part #54900IS

Illustration A

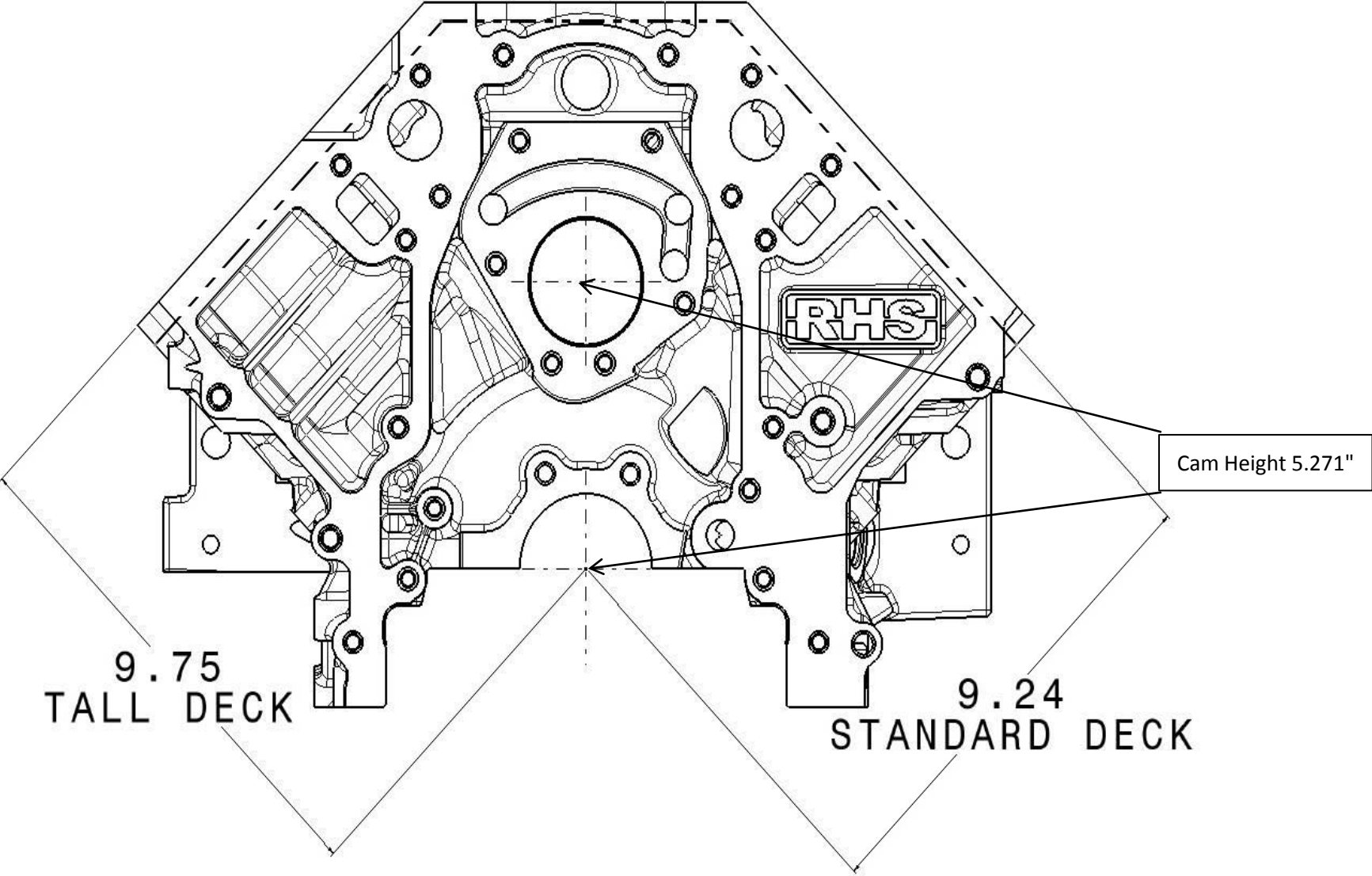

Illustration B

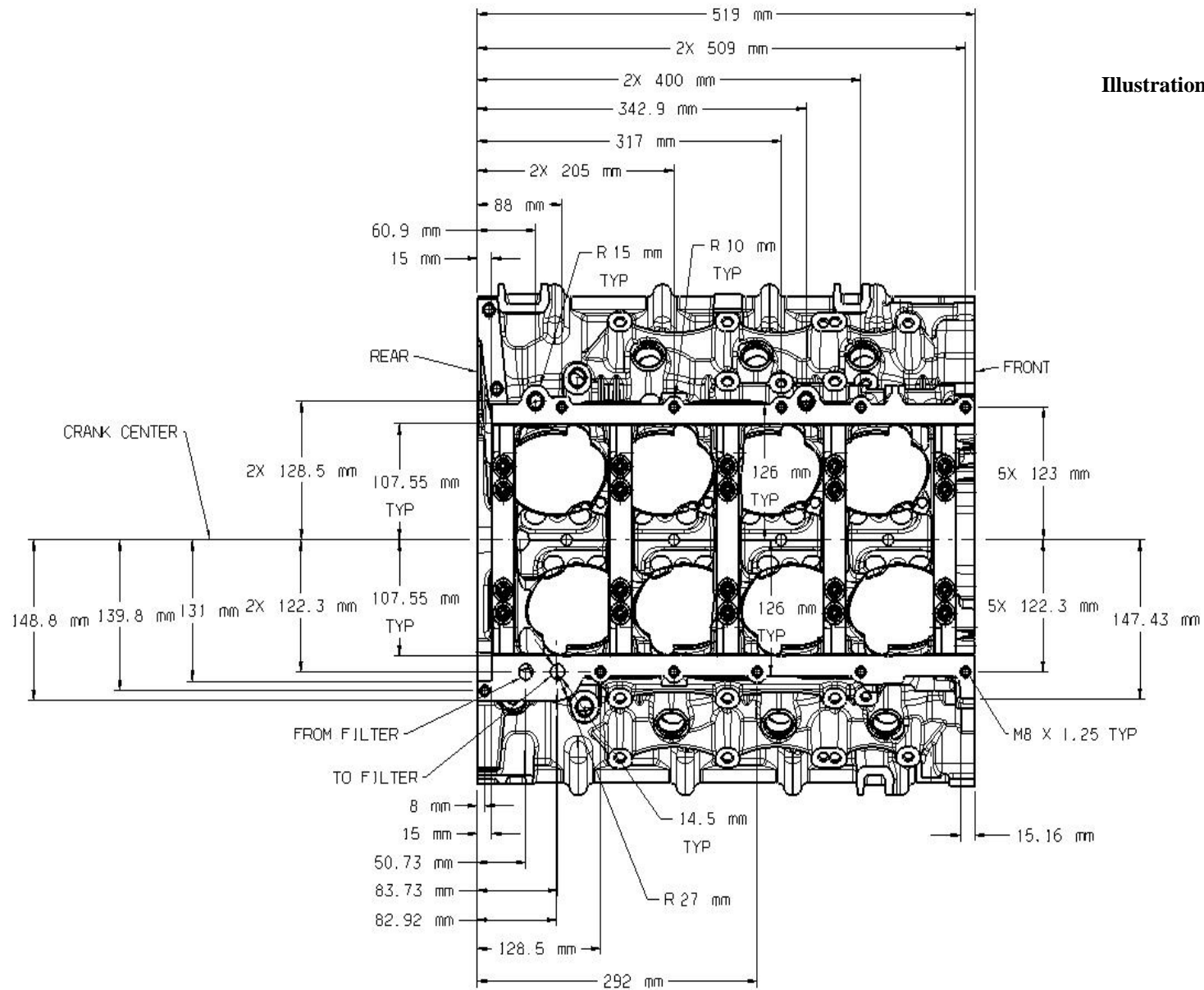

Illustration C

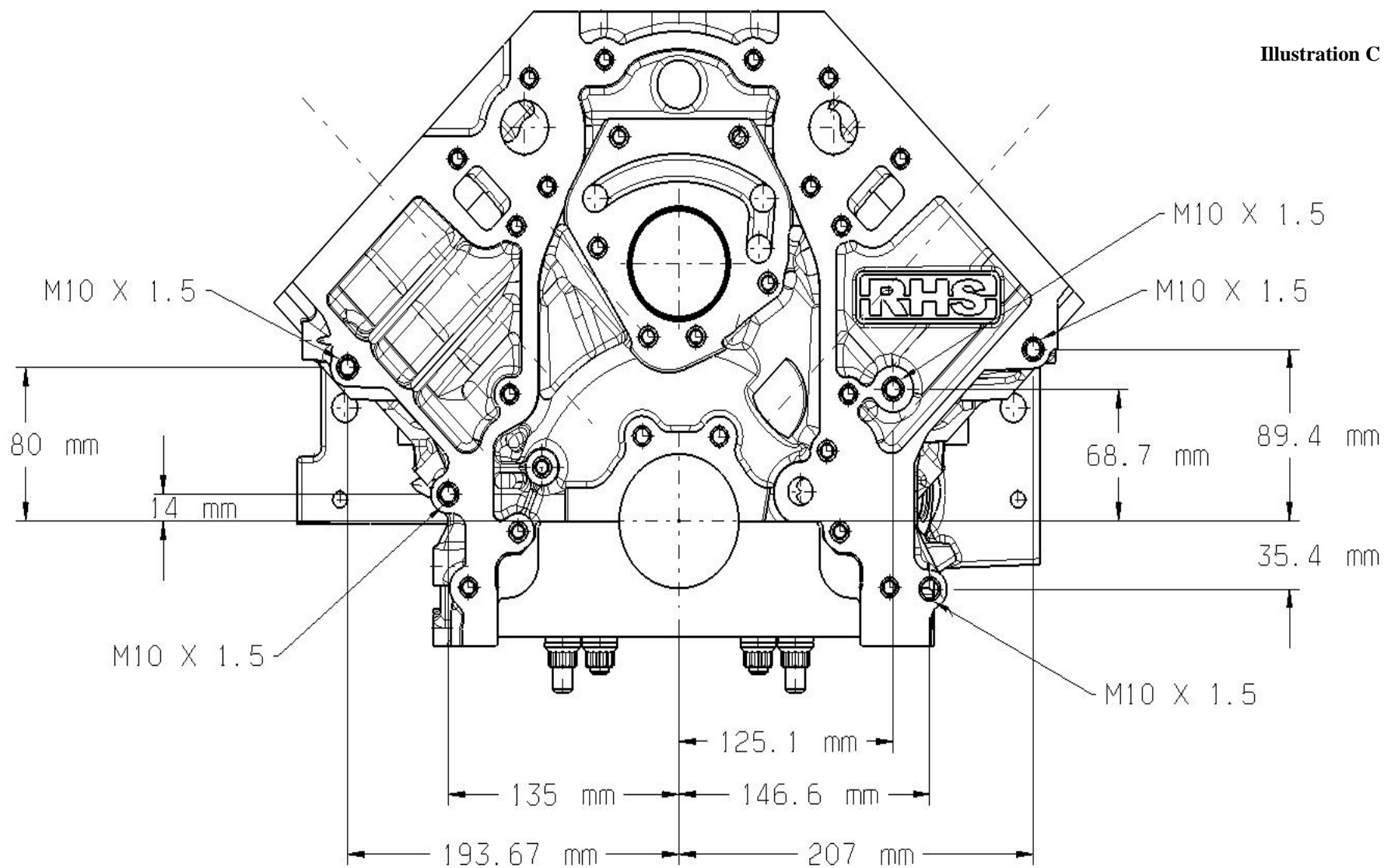
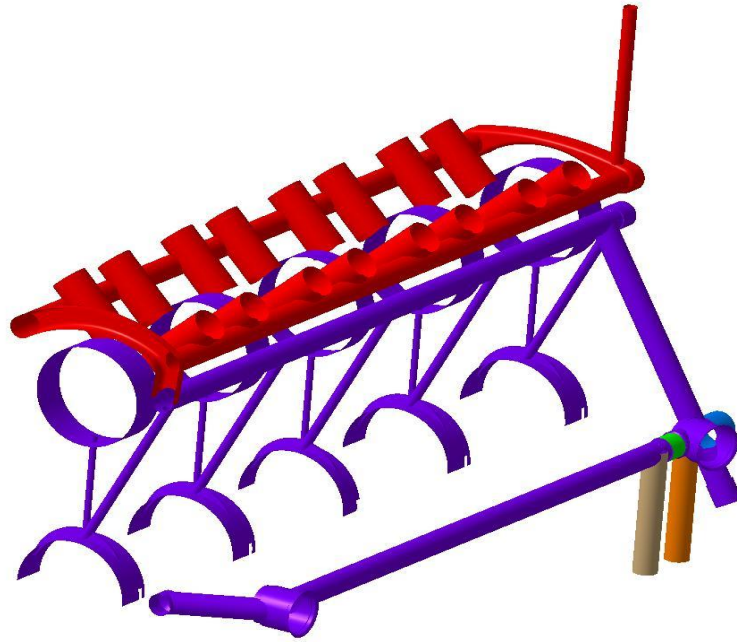

Illustration D



Barbell plug replaced with NPT plugs

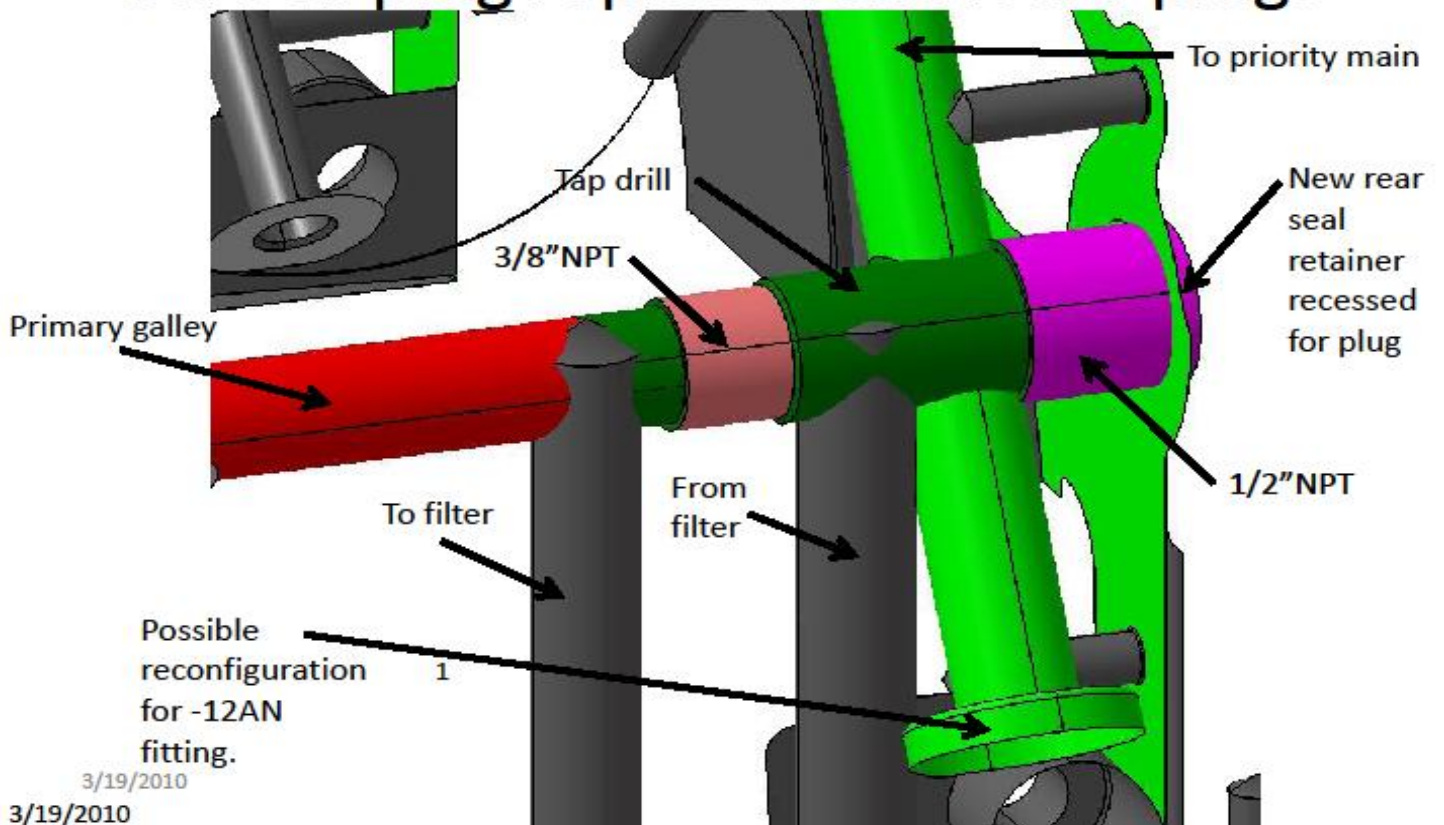
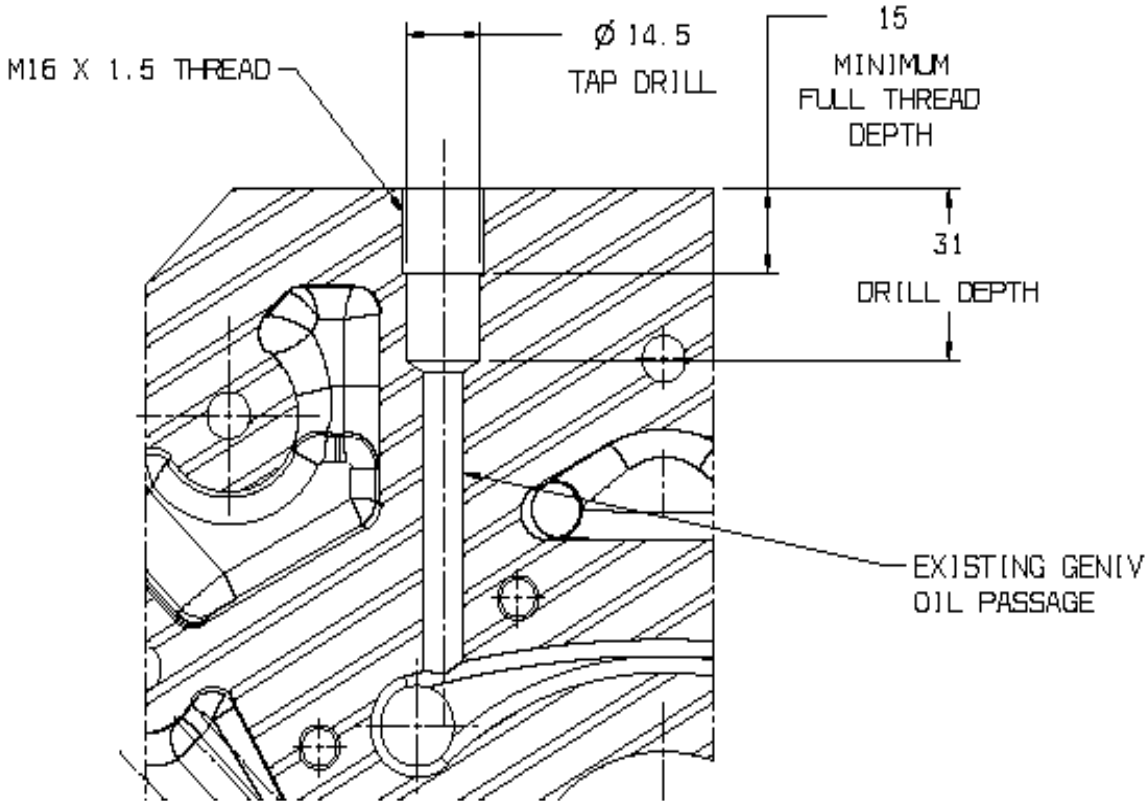
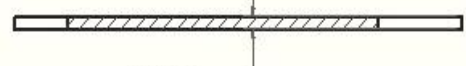
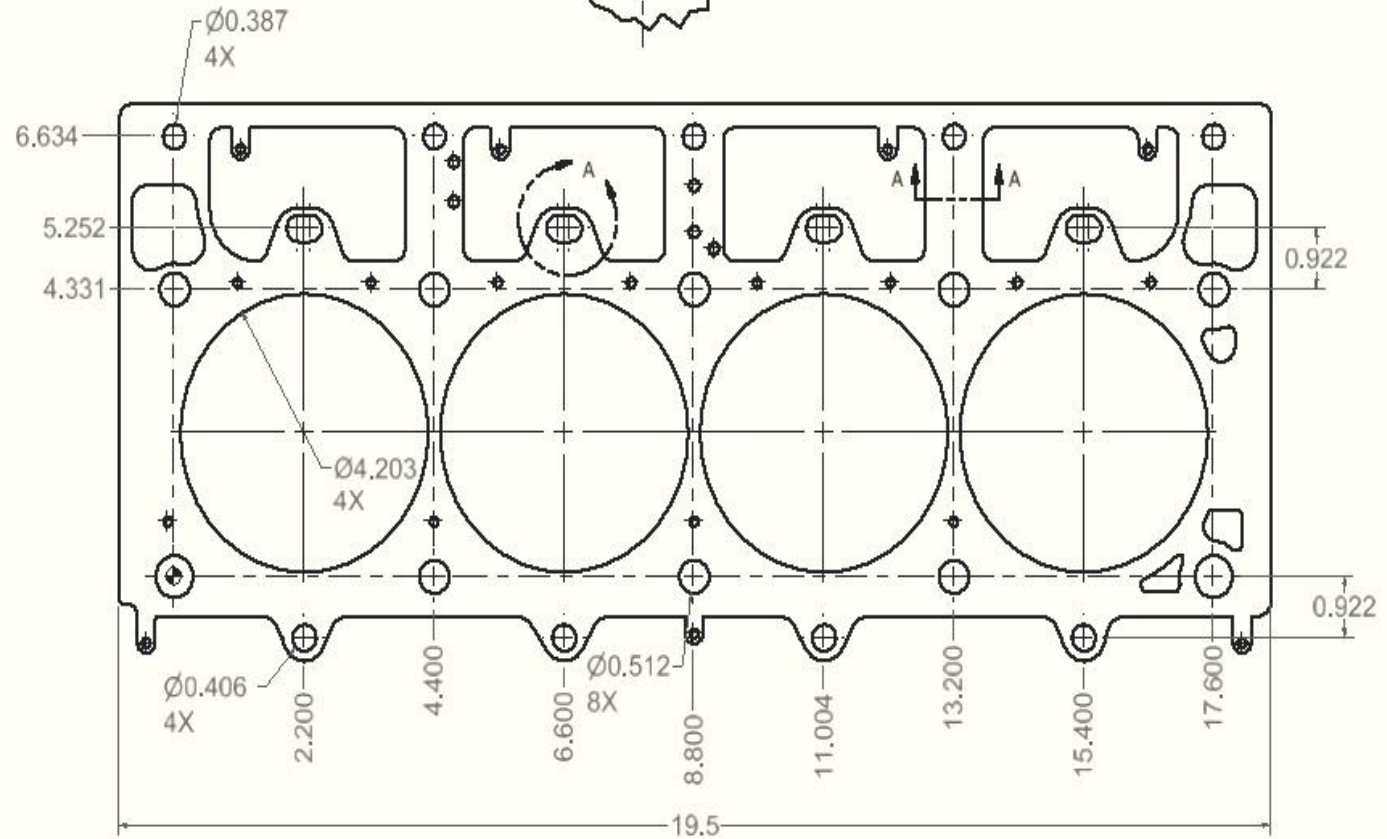
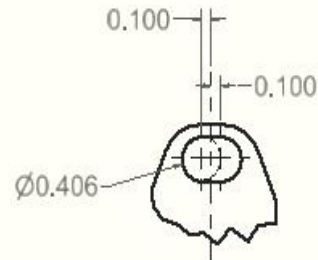

Illustration F

RHS BLOCK - DRILL AND TAP FOR GM12569323 OR EQUIVALENT OIL PRESSURE SENSOR FOR USE WITH GENIII VALLEY COVER AND M16 METRIC THREADS.



NOTE: ALL DIMENSIONS ARE NOMINAL.



0.036
COMPRESSED THICKNESS
WITHOUT STOPPER THICKNESS (0.005)