



Assembly Instructions Round Style 30x65x15-4 Industrial Round Style Building

ASSEMBLY INSTRUCTIONS ROUND STYLE 30x65x15-4

Please read instructions completely before you begin. This will help attain the best results for your installation.

CONGRATULATIONS!

Congratulations on your purchase of a MDM Products 30x65x15 Round Style Portable Building. With proper installation, use, and maintenance your new unit will provide many years of good and suitable service. Your new MDM Products portable enclosure is a combination of excellent engineering and well thought out design. The unit is comprised of a rigid tubular frame, covered with a long life polyethylene cover and door ends.

The multiple part frame assembly is pre-drilled for easy insertion of frame bolts. The tubing is made from high-grade galvanized steel, resisting moisture and oxidation over the life of the shelter. The cover and doors are made from **ASTM-5** approved polyethylene materials. The cover is UV protected for exposure to sunlight.

SAFETY WARNING

The installation of this unit must conform to the requirements of all authorities having jurisdiction in your specific local area. In the absence of such requirements, the assembly and installation must conform to the provided assembly and installation instructions. MDM Products, LLC will not be responsible for failure to comply with any requirements in a given local area. Damages, consequential damages, or injuries caused by improper installation, alteration, improper use, or damages caused by snow, wind, or any acts of nature are strictly that of the user. Unit is not intended for occupancy for any length of time.

Crates should be inspected upon delivery from carrier, and any evident damages should be noted on the bill of lading before signing. If upon opening the crates hidden damage is discovered, contact carrier or it's agent immediately. Claims for shipping damage **MUST** be made with the shipping company. An inspection of the

goods will most likely be required. Do not discard packing or any components before the freight company inspection. All claims for freight damage must be made within 15 days of receipt of the goods in accordance with ICC regulations.

The proper erection and installation of this building requires a high level of care and safety. MDM Products **strongly recommends** that all OSHA safety regulations be complied with. This includes but is not limited to:

- x **Safety Hats, Protective Eyewear and Protective Clothing**
- x **Safety Harnesses for all Elevated Workers**
- x **Proper Ladder, Cage, and Safety Equipment**

Due to the size of some building components, some power equipment may be required or used. Operators must be trained and fully capable of safe operation.

ASSEMBLY PROCEDURE

The proper sequence and steps to install this unit will produce a proper and good installation. Failure to read and follow these guidelines may result in an improper installation and will void all warranty and protection the owner is entitled to with the product. The overall steps to be undertaken are:

1. Perform an inventory check before beginning, to be certain all components are available for installation.
2. Prepare location and place all unit boxes near location sight.
3. Assemble Seventeen (17) Arch Assemblies of unit.
4. Secure Baseplate Flanges to Base Surface.
5. Begin Frame Assembly with End End Arch, first Interior Arch, and Wind Braces with the first ridge crest, and side rail sections.
6. Add additional Interior Arch Assemblies with each section of side rails.
7. Add Rear Arch Wind Braces.
8. Install End panel Framing.
9. Install Main Cover over frame assembly.
10. Install End Fabric Panels over End panel.
11. Install Rear Fabric Cover over Back Panel.
12. Install Mechanical Roll Up Door

Assembly Instructions Round Style 30x65x15-4 Industrial Round Style Building

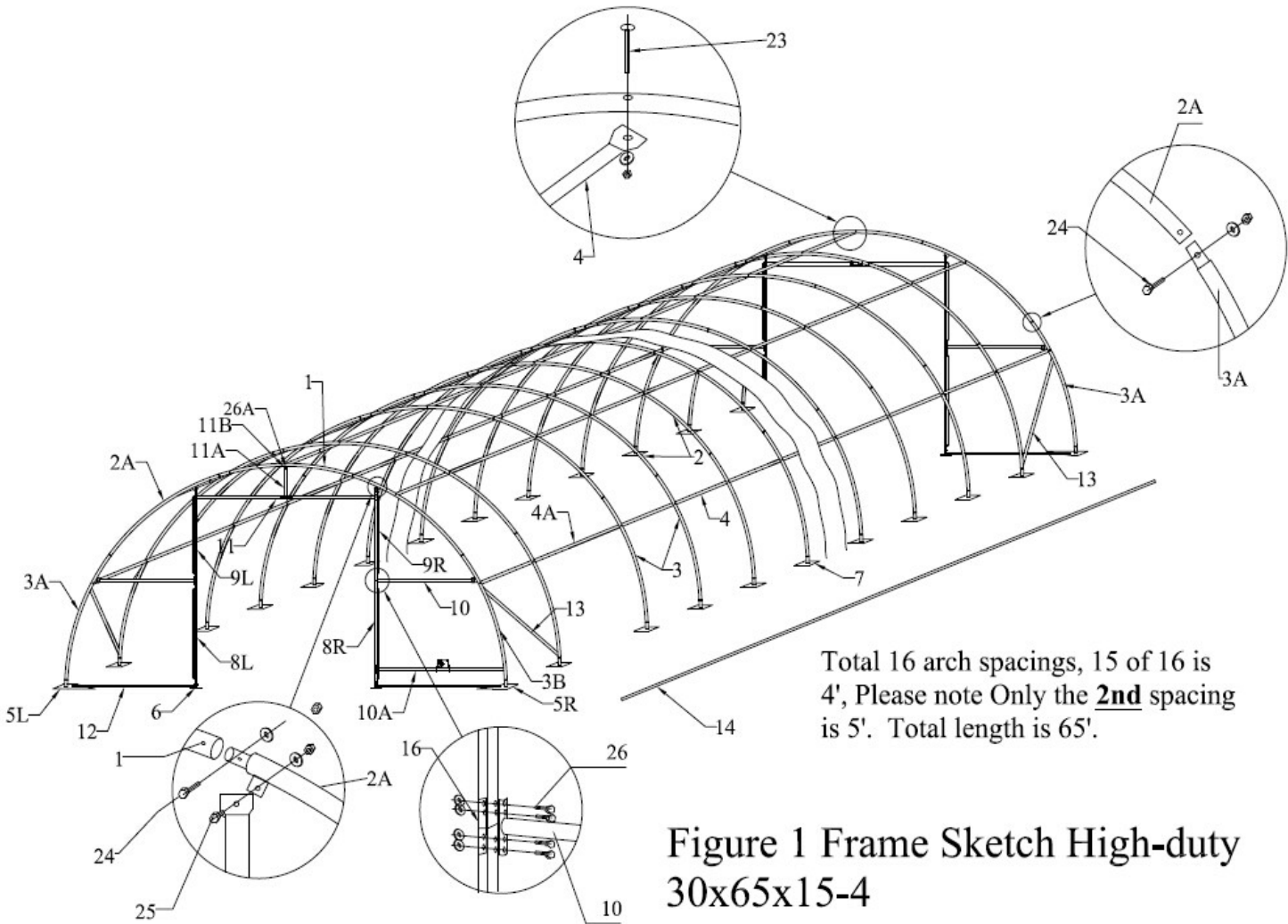

Assembly Instructions Round Style 30x65x15-4 Industrial Round Style Building

TOOLS REQUIRED

The following hand tools will be needed for proper installation of your new MDM Products building:

- x 12mm, 14mm, and 17mm Open End Wrenches
- x 12mm, 14mm, 17mm Sockets or Box Wrench
- x Large Flat Head Screwdriver
- x 2lb maul or Sledgehammer
- x 4-Foot Level, 14' Step Ladder
- x Stakes & String for aligning Base Plates & Frame

INVENTORY CHECK

Start installation procedure by removing all components from packaging to ensure all components are present. Inventory chart appears on the last page of this manual.

SITE SELECTION & PREPARATION

Select a level or as close to level as possible location for your MDM Products Building. As the components fit into each other as a level unit, there can be no more than 1 inch difference between one base flange and another. Time spent preparing the base will pay off in years of good operation without binding of parts and doors.

The best location is on top of a poured concrete pad. At minimum, the building should be placed on a base of materials suitable for the storage load to be protected. If not on concrete, typical construction would be a 6" bed of crushed process rock, compacted with a vibrating compactor, with blocks underneath the location of the base flanges. Sides can be mounted on top of wooden timbers or piles driven into the ground at the correct elevation.

The unit should not be located under trees, which will shed hard fruit such as apples, walnuts, or heavy pinecones. The cover of your unit will protect against normal falling leaves and light debris; however, large branches or other falling items may cause a puncture or tear in the cover material.

Take notice of drainage around your intended location. Water draining from the surrounding terrain should be planned so that it does not run into the unit. As well, rain or melting snow that comes off the unit should be drained away rather than accumulate and pool around the unit.

Check to be certain that adequate clearance is allowed for entry and exit.

When selecting a location for the building, consideration should be taken of the ability of the ground to keep the base flanges in place, as well as support the weight of the building and content. Using the stakes and string, measure off and square area for intended installation. Level the ground as best as possible. A properly leveled frame yields maximum strength.

ARCH ASSEMBLY

Step #1 -Assemble Arches

Unit consists of two (2) End and fifteen (15) Interior Arches. Assemble each arch on ground. Begin by laying out the components of the End Arches.

End Arch consists of:

One (1) Top Ridge Tube (1)

Two (2) End wall Curved Roof Tube (2A)

Two (2) End wall Sidewall Tubes with Wind Brace supports (3A)

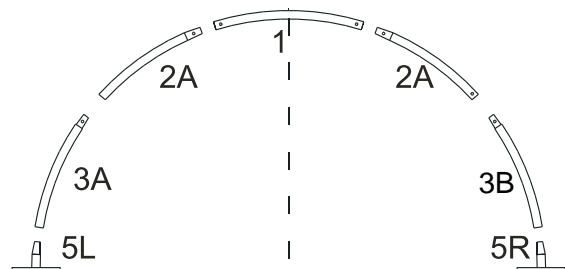

Components slide into each other at the ends. Sidewall tubes (3A) must be faced so the clips for Wind Brace Supports are facing to the next interior arch. Secure them together using 8mm x 70 mm Hex Bolt(24) washer, and nuts. Only snug up nuts, do not over tighten nuts.

Use 10x80mm hex bolt(24) with Washers and Nuts through pre-drilled holes in frame members. Be certain to insert bolts from the outside into the interior of the unit, with the washers and nuts on the inside of the frame. This will prevent the bolts from puncturing through the cover material. Do not tighten down the nuts completely until frame is fully assembled and set in place.

Assemble each of the 15 Interior Arch Assemblies.

Assembly Instructions Round Style 30x65x15-4 Industrial Round Style Building

Each Interior Arch consists of:

- One (1) Top Ridge Tube (1)
- Two (2) Curved Roof Tubes (2)
- Two (2) Sidewall Tubes (3)

each side of assembly. Standing Leg Base Plates are positioned along the End Arches to secure vertical beams in each.

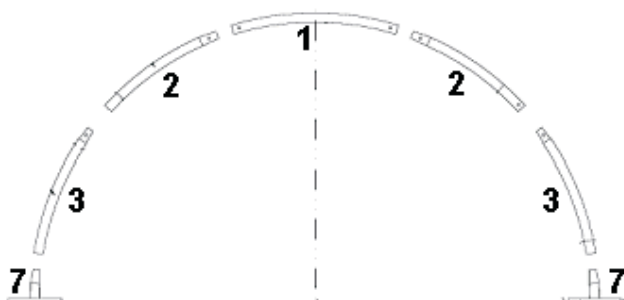

SECURING BASE FLANGES

Step #2 -Secure Baseplate Flanges in Position

In order to assemble arches into a frame assembly, the Base Flanges (5L, 5R, 6, & 7) must be secured to the mounting surface. Refer to Figure 2 for an exact layout of all base flanges.

Begin by determining exact location of the four (4) corners of the building. Mark End edge and side-to-side width of assembly on ground if not on concrete pad. Drive alignment stakes into the ground outside of the markings, and draw alignment strings along both ends and sides of the building to the dimensions shown in Figure 2.

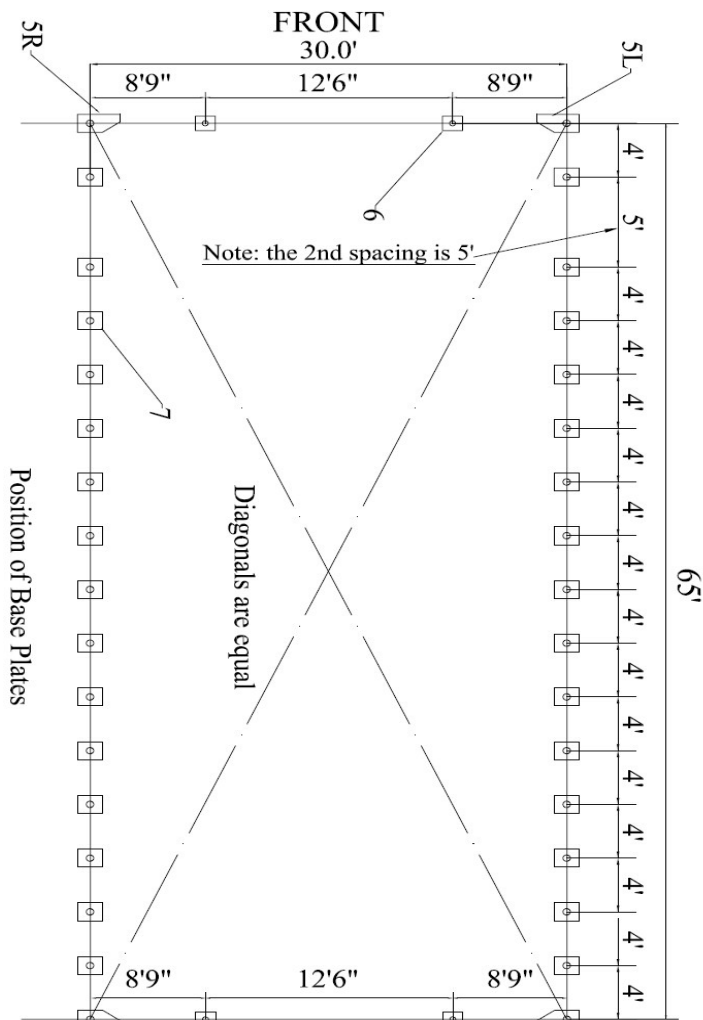

The outline of the strings will represent the final location of the baseplate flanges. The initial location of each Corner Base Flanges (5R & 5L) is critical to the alignment and fit of the frame components and cover. Locate the Left Corner Base Flange (5L) and Layout and secure all Base Plates in position as shown in Figure 2. Please Note that Only the 2nd spacing is 5'.

Note that Sidewall Base Plates (7) and Base Plates End Standing Legs (6) are different and not interchangeable. Sidewall Base Plates are used only along Right Corner Base Flange (5R) for the End corners of the building. Secure the base flanges with either or both the Auger style anchor (19) and the Earth style anchor (20). Measurements shown in Figure 2 are to the center of the upright sockets on each Base Flange.

Assembly Instructions Round Style 30x65x15-4 Industrial Round Style Building

The 65x30x15 building must be secured to a firm surface that can receive and retain anchors firmly in position. Both Auger Style and Earth Style anchors are included within this assembly kit. If securing to the ground or to blocks that might shift later, it is recommended that both style of anchors be used to avoid base flanges moving during or after assembly. If securing to a concrete pad, blocks, or other hard surfaces, anchors must be field supplied. Regardless of base material, the Base Flanges must be secured so they cannot be moved. Arches are tensioned at their base as they insert into the base flange sockets.



Installation of Earth Augers

Using one base flange as a panel, mark the Earth Auger location hole through the base flange by pushing the Auger point through the base flange hole in place. This will leave an impression in the ground when the base flange is removed. The auger tip should be started into the ground where the depression under the hole was made.

After the hole is marked, move the base flange to one side to expose the impression for the Auger. Using the specially designed Earth Auger Wrench (30), turn the earth auger into ground. Leave sufficient shaft above the ground to allow for the base flange thickness and adequate thread to be exposed for the washer and nut to be tightened over the base flange.

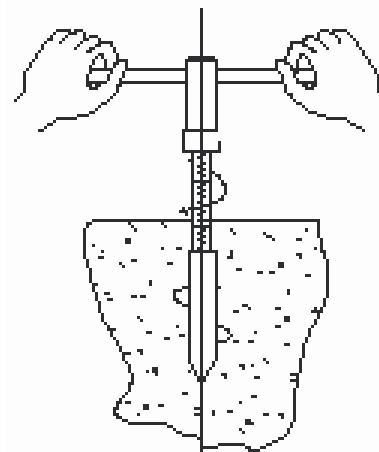

Replace the base flange into place, with the threaded shaft of the auger sticking through the base hole. Re-check the dimension from the corner or adjacent base flange before tightening. Tighten the nut and your assembly will be securely fastened to the ground.

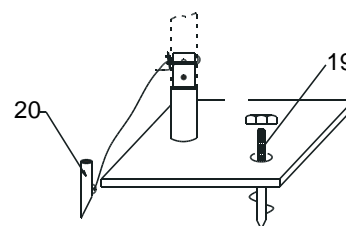

Figure 3

As Figure 3 shows, each base flange is equipped with one piece of auger and one piece of earth anchor.

Follow the above procedures for each subsequent Base Flanges of the assembly. It is suggested that you begin with the four corner anchors to be used as reference points to the next base flange. Alignment and dimensions should be checked continually as Base Flanges are secured.

Assembly Instructions Round Style 30x65x15-4 Industrial Round Style Building

Installations of Earth Anchors

Each MDM Products 40x30x15 building comes with 26 EARTH CABLE ANCHORS (20) with U-bolts and nuts (21). These versatile anchors allow the frame to be secured to almost any surface. In addition you have also been provided with a 36" Drive Rod (22) used to drive the anchor heads into the earth.

If the location where you are placing the building has very hard ground or any rock in it, pre-drill the holes before inserting anchors. Hammer drills can be rented at most home improvement or rent-all centers. Hitting the anchors into rock will cause the drive rod end to mushroom inside the anchor head, and prevent the drive rod from coming out of the hole.

Anchor placement should be made inside the frame. Anchors secure the building to the ground to prevent spread of the frame over time.

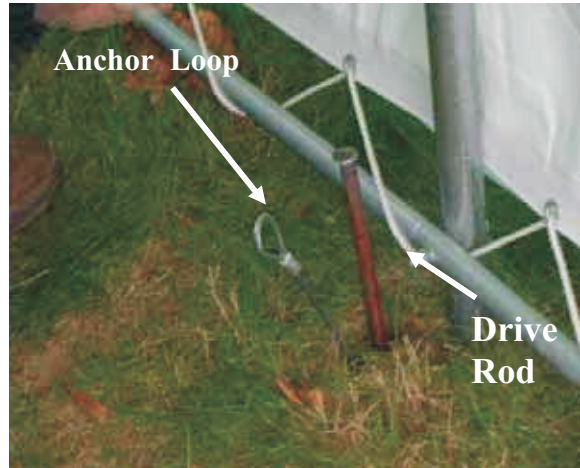

EARTH ANCHOR STEP 2

Place the Drive Rod through the loop in the anchor lanyard. Pull upward to set anchor head into the ground.



EARTH ANCHOR STEP 1

Step 1. Place the drive rod provided into the cup of the anchor. Using a heavy hammer drive the anchor into the soil until 6-8 inches of cable remains above the earth. Remove drive rod.



EARTH ANCHOR STEP 3

Slip one side of the U-bolt (21) through the eyelet at the end of the anchor cable. Attach the cable to the base flange socket with the U-bolt and tighten. Ensure there is no slack in the cable. Slack can be removed by wrapping the cable around the base flange upright socket.

Use Carriage Bolts with Washers and Nuts through pre-drilled holes in frame members. Refer to detail drawing for correct hardware. Be certain to insert carriage bolts

Assembly Instructions Round Style 30x65x15-4 Industrial Round Style Building

from the outside into the interior of the unit, with the washers and nuts on the inside of the frame. Do not tighten down the nuts completely.

ERECTING ARCHES

Step #3 -Combining Arches Into Frame

Begin frame assembly by erecting End Arch into End Corner Base Flanges. Place left frame sidewall tubing into the upright tube socket into the Left Base flange. Place 8 mm x 70 mm Bolt (24) through base flange socket and arch sidewall tube hole.

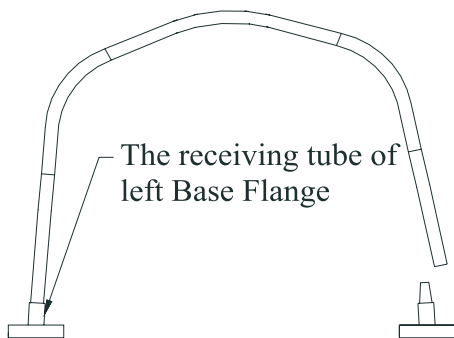

In order to insert Right Sidewall Tube into Right End Corner Flange, it is necessary to support arch on left side to prevent movement. Position Right Sidewall Tube over Right Corner Base Flange. It will be necessary to push arch assembly inward to fit into Right Base Flange Upright Socket. This tension is normal, and will help rigidity of completed frame assembly.



Once right sidewall tube is placed into right corner base flange, insert a 8 mm x 70 mm bolt and nut (24) to prevent it from popping out of the socket while assembly continues.

Next stand first interior arch up to repeat insertion into Base Flanges. Place left sidewall tube into the upright socket of first interior Base Flange. Put 8 mm x 70 mm bolt through base flange and sidewall tube to secure in place.

Supporting the left side of arch, pressure arch assembly inward to put right sidewall tube into right side Base flange upright socket.

Immediately after putting first interior arch into place, connect End Arch and Interior arch using Cross Rail Tubes (4) at top ridge and side shoulder curves of arches. Secure the Cross Rail tubes (4) into place using 10 mm x 80 mm Carriage bolts (23) and nuts.



Note: Cross Rails (Purlin Horizontal Tubes) (4&4A) are secured inside the arch assemblies

Note: The Long Cross Rails (4A) are for the 2nd spacing that 5'.

Use 10 x 80 mm Carriage Bolts with Washers and Nuts (23) through pre-drilled holes in frame members. Refer to detail drawing for correct hardware. Be certain to insert carriage bolts from the outside into the interior of the unit, with the washers and nuts on the inside of the frame. Do not tighten down the nuts completely.

Next install the Wind Brace supports that connect the End Arch to the first Interior Arch (#2). Use two Wind Brace Supports (13) between the

Assembly Instructions Round Style 30x65x15-4 Industrial Round Style Building

sidewall tubes. Use a Wind Brace Clip (13A) at the end of each Wind Brace support tube. The Wind Braces give the arch assemblies strength as a unit.

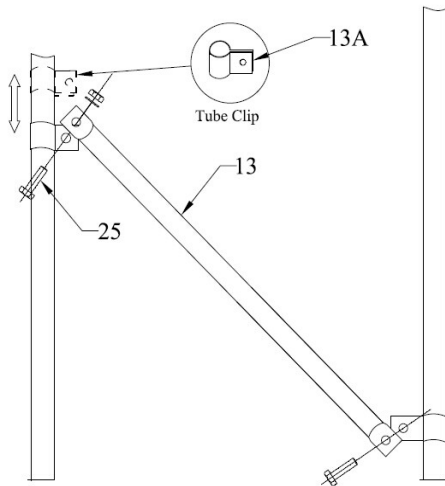

Use Bolt 10 mm x 30 mm (25) at the end of each Wind Brace Support to secure. Check level of arch upright before final tightening of Wind Brace Clip (13A). Slide clips as needed on Arch Sidewall until Arch is level and plumb.



Cross Rails Inside Connect Arch Assemblies

Install Interior Arch #16 (next to Rear Arch), with the Wind Brace Support Tabs on the Sidewall Tube (3D) facing the Rear End Arch. Install Rear End Arch into Base Flange Sockets. Install final Cross Rails (Purlin Horizontal Tubes) and Wind Cross Brace Assemblies as described above. Check end Arch for plumb before securing the Wind Brace bolts tight.

Next check entire frame assembly for square and plumb. Adjust Wind Braces and Cross Rails (Purlin Horizontal Tubes) as necessary to being frame into plumb. Next tighten frame bolts adequately. Do NOT over tighten bolts so as to oval or compress frame components.

ERECTING END WALL ASSEMBLIES

Step #4 Assemble End Wall Framing

The Front and Rear Arch and Door Assembly of this building are identical. All steps and instruction for an End Arch apply to both the front and rear of the building installation.

Assemble Side Beam for End panel from Upper Door track(9L,9R) and lower door track(8L,8R). Support Door Track with Upper Beam of End panel (10) at junction point. Lower Door Track goes into Base Flange (6) at the base. Upper door track secures to Curved Roof Tube (2A) at top with 10 mm X 30 mm Bolts (25). Repeat this assembly procedure for both left and right side of End panel for Door. Do not fully tighten bolts and nuts until all framing is in place and plumb.



Continue to install Interior Arch Assemblies #3, #4, to #15 in the same manner. Overlap pinched ends of Cross Rails (Purlin Horizontal Tubes) onto same 10 mm x 80 mm carriage bolts inside frame assembly.

NOTE: The 2nd spacing is 5' , should assemble the Long Cross Rails (4A) on this spacing.

Assembly Instructions Round Style 30x65x15-4 Industrial Round Style Building

Assemble Door Beam (11) across Upper Door Tracks with support tube(11A) and splint plate(11B).Next assemble Lower Beam of End panel (10A) on right side of assembly. This beam will support door roll up assembly.



is plumb, tighten nuts and bolts adequately. Do not over tighten hardware to compress or oval frame members.

MOUNT TIE DOWN RATCHETS TO BASE PLATES

Step #5 -Bolt Ratchets to Base Flanges



MAIN COVER INSTALLATION

Step #6 -Prepare Frame and Position Main Cover

To elongate the life of Main Cover, put a small square of duct tape (field supplied) over each bolt head on frame that comes in contact with cover. The tape acts as a cushion to avoid rubbing damage to the cover over years. As an alternative, foam rubber pipe insulation makes a good cushion between the bolt heads and the main cover as well.

When ready to install Main Cover(31) , unpack cover and lay parallel to building frame on one side. Cover must be pulled over top of frame assembly without being snagged or stressed on any frame members. Use multiple ropes over top of frame as shown in picture below. Having several people inside frame on ladders to assist in getting Main Cover (31) over frame will insure cover will go on without any damage.

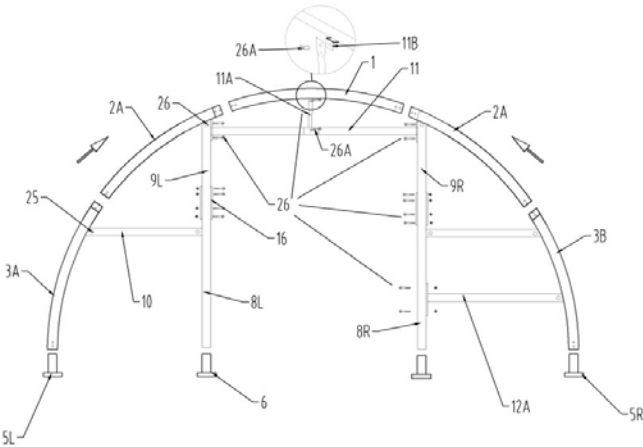

Once all frame members are in place, use a level to check for plumb and square. Adjust as needed. After all

Assembly Instructions Round Style 30x65x15-4 Industrial Round Style Building



Step #7 -Tension Cover On Frame Side-To-Side

Center Main Cover over Frame assembly both side-to-side and End to back. Next insert Tensioning Tube Plastic Caps (28) into the ends of the Tensioning Tubes (14) as shown in Figure 13. Insert the Tensioning Tubes into the pockets in inside edge of Main Cover on each side. Align one side of Main Cover evenly End to back. Put Band for Tie Down Ratchets (27) over Tensioning Tubes at each Base Flange along one side. Bands do not attach to Tensioning Tubes, but loop around and secure at both ends on ratchet.

Next take up slack in tie bands by ratcheting the mechanisms tightening cover. Evenly adjust ratchets on both sides of main cover to take wrinkles out of main cover. **DO NOT** fully tighten cover yet. Leave adequate slack so that cover can also be adjusted End to back in next step.

Assembly Instructions Round Style 30x65x15-4 Industrial Round Style Building

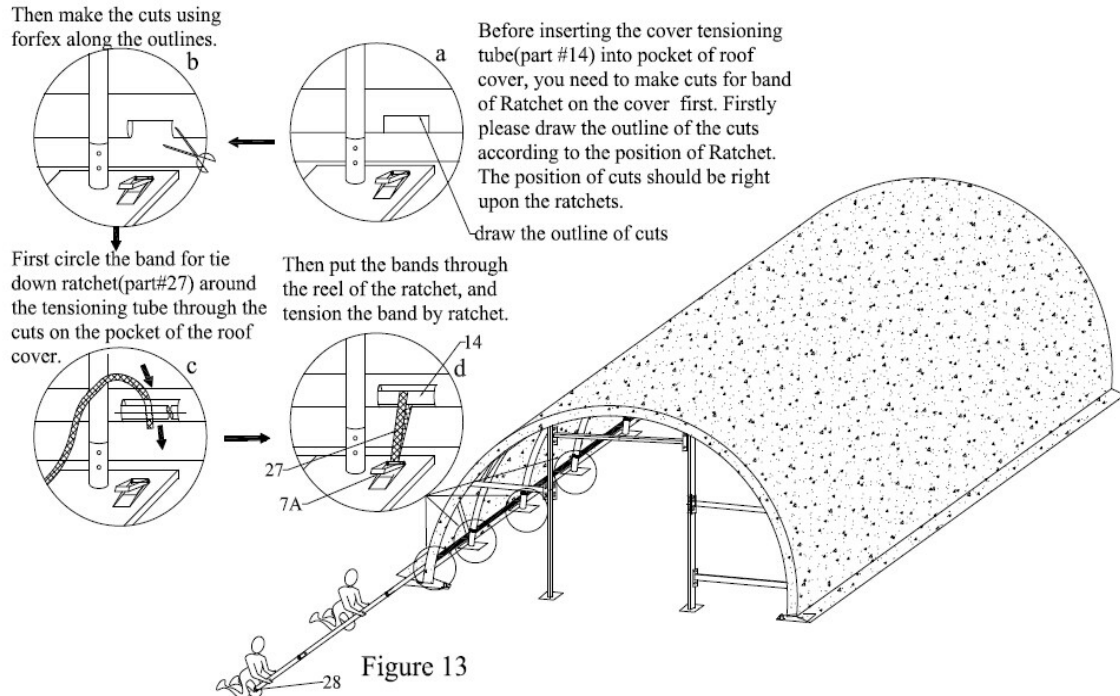

Step #8 -Tighten Main Cover on Frame End To Back

The main cover is tensioned from End to back by the rope (29) lacing to grommet flaps inside the main cover, inside the unit at End arches. Using the rope (29) provided, lace the main cover grommet flap around the main frame End arch pieces. Start in the top middle of each arch, and lace to each side. Add rope (34) length by tying pieces together or cutting as necessary.



Rope Lacing Main Cover End-To-Back

Begin with each End arch at the top. Pull the rope through the middle grommet until both ends of the rope meet. Loosely lace the rope down each side, without pulling the rope taut yet. Then lace the other End Arch grommet flap to the rear arch frame the same way. Tie off one end to the lower frame member. Now go back to the top again, and start taking the slack out of the rope evenly along the edges. If necessary, loosen up on the tensioning pole ratchets so the cover can be adjusted end to back. Adjust both the Endlace rope so that there is an even amount of material at each End Arch. Pull only tight enough to get all excess material out of the main cover over the frame members. Do not pull so taut that the grommets stress the main cover flap.

After the main cover lacing is adjusted evenly across the grommet flap, go back and re-adjust the Tensioning Ratchets along the side edges of the Main Cover. At this point, the main cover can be pulled taut enough to take all excess material and wrinkles out of cover. It will be necessary to repeat this step 2-3 weeks after unit assembly is complete and main cover has a chance to stretch out over the frame completely.

Assembly Instructions Round Style 30x65x15-4 Industrial Round Style Building

ASSEMBLE END COVER ON ARCH PANEL FRAMES

End Panel Covers - The Fabric Covers for each End wall consist of three separate fabric pieces. Two Side Panels (32) are installed on either side of the door frame opening. One of the panels has a cut out in it for the Winching Mechanism. This should be installed on the right hand side of the frame when facing door from the outside.



These pieces secure to the End panel Frame with Rope(29) around the frame members at each

Step #9 -INSTALL END ARCHES (2) FABRIC PANELS

grommet. Start securing the side covers at the bottom and work up towards the top. At the bottom of the panel, use one of the ropes provided to lace the fabric to the Lower Beam(12). A separate fabric cover, Cover above

End Door Panel is provided. Make certain to put Rope(29) along the horizontal frame members as well as the perimeter of the panel.

Main Cover Edge Tie Off - Once both End Panel Covers are installed, the Main Cover Edge flap, End, should be tightened and tied off. Begin by pulling the remaining Main Cover Material over the Frame arch, so the rope pocket is over the edge of the frame. Tie off the rope that goes through the rope pocket on one side. The rope ties off to the loop that is located on the Base Flange Corner (5L or 5R). Moving to the other side, begin to pull the rope down. Hold the rope in hand, and push down at the bottom of the rope with a foot. Pull the rope tight, and tie off to the welded hoop on the Base Plate. As you are pulling the edge rope, it will be necessary to adjust the excess material that will collect along the rope packet. Adjust the material so that it is not bunched up and it does not pull the main cover to one side or the other. Once the End is completed, repeat the process on the Rear flap of the Main Cover.

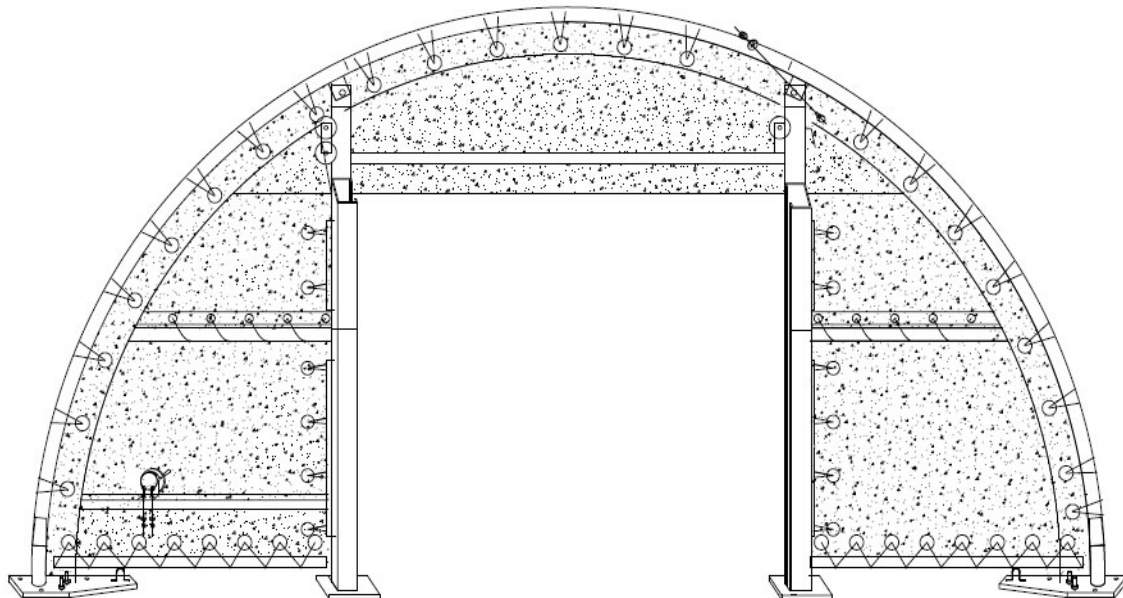

Assembly Instructions Round Style 30x65x15-4 Industrial Round Style Building

ASSEMBLE MECHANICAL DOOR - EACH END

Step #10 - Install Main Door, Cover, and Opener

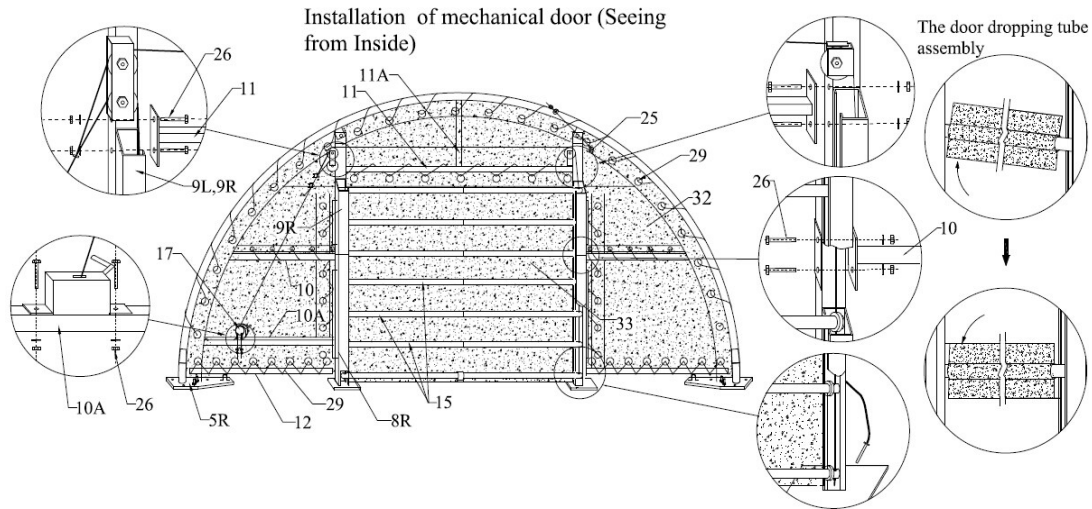

Mechanical Door Installation Steps-

1. Install Main Door Pulleys (left and right) over the Top of the Door on each side of the Door Beam (10A).

2. Next mount the Winch Mechanism to the End panel lower beam (10A). Mechanism should line up with pocket in Fabric End Side Panel. Use 10 mm x 80 mm Bolts and Nuts (26) to secure the Winch Assembly to End panel Lower Beam (10A)

3. Slide Bottom Dropping tube(15) into the bottom horizontal fabric pocket on the Door Cover (33). Then slide the six remaining middle door Dropping tubes (15) into the remaining horizontal fabric pockets in the Door Cover.

4. From the bottom of door tracks(8L,8R,9L,9R) gently raise and slide one door dropping tube (15) into the tracks. And then feed the other remaining door dropping tubes (15) into the door tracks.

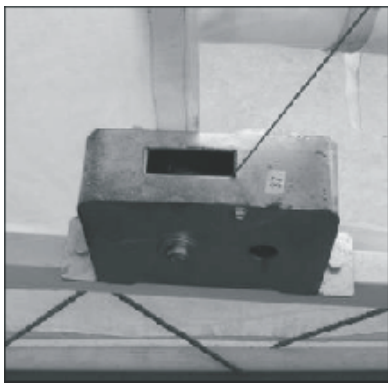

Winch Assembly Mounted To Lower End panel Beam

Assembly Instructions Round Style 30x65x15-4 Industrial Round Style Building



5. Next install the steel wire that leads from the door winching assembly to the bottom of the door dropping tubes. The Winch Assembly has a long and a short steel cable secured to it. Feed the end of the shorter of the two cables through the lower roller of the double pulley at the top of the door assembly track closest to the Winch Assembly, and then down through the holes in the bottom door dropping tube (15) on the left hand side of the door (facing from the inside). When the steel cable goes down through the hole in the bottom dropping tube(15), tie a knot in the steel wire so that it cannot pass back up through the hole.



Door Tubes Inserted Into Door Track



Double Pulley Nearest Winch Assembly

Assembly Instructions Round Style 30x65x15-4 Industrial Round Style Building

6. From the Winch Assembly route leading end of the Longer Steel Cable through the Upper Roller of the double pulley near door track and then through the Single Roller on the door track farthest from the Winch Assembly. Then down through the bottom door dropping tube (15). When the steel cable goes down through the hole in the bottom door dropping tube (15), tie a knot in the steel cable. Door can now be opened or closed by operating the Winch Assembly. Raise and lower the door several times to be certain door tube ends are not binding on track. Lubricate if necessary.



Single Door Pulley Farthest From Winch Assembly

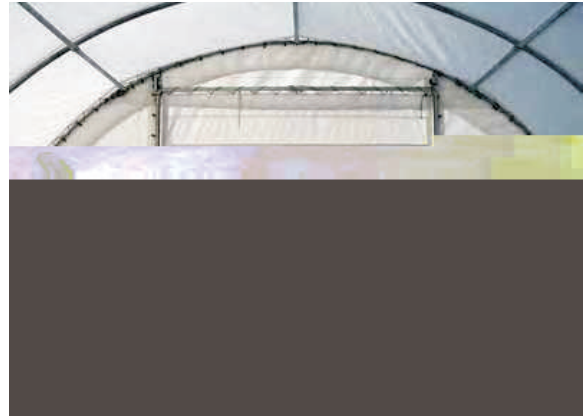

Door in the fully Closed Position

Door can now be opened or closed by operating the Winch Assembly. Raise and lower the door several times to be certain door tube ends are not binding on track. Lubricate if necessary.



Main Roll Up Door in fully Open Position

Assembly Instructions Round Style 30x65x15-4 Industrial Round Style Building

Door Locking Kits

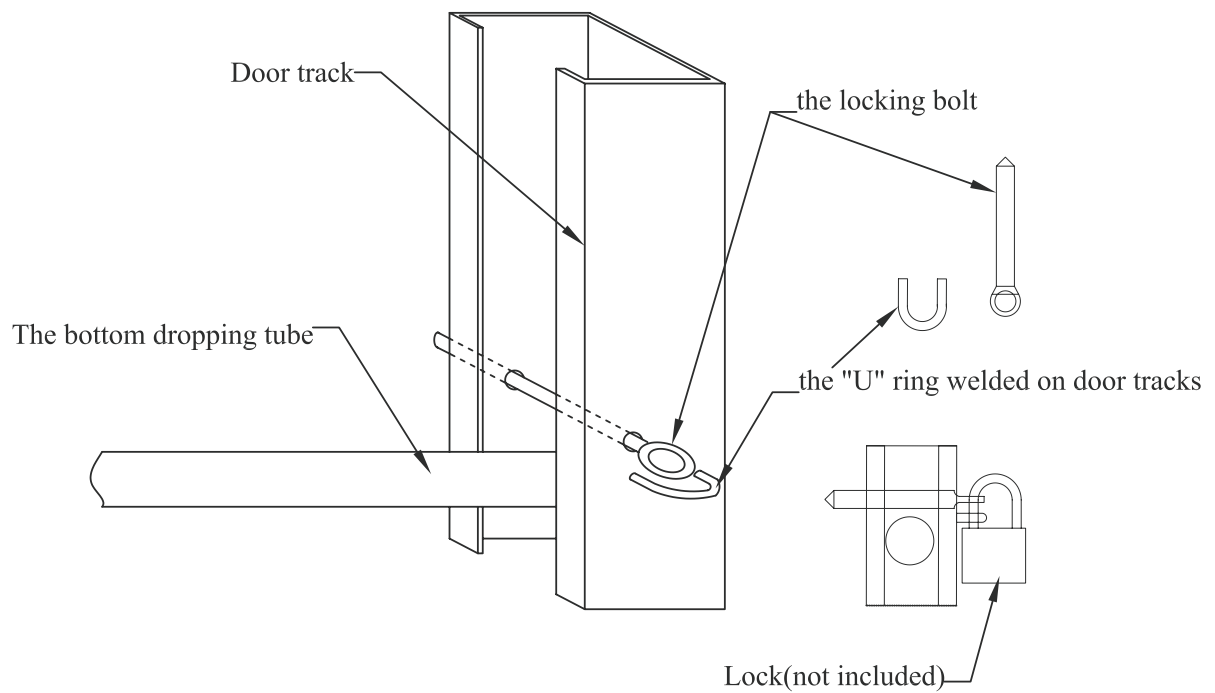

Assembly Instructions Round Style 30x65x15-4 Industrial Round Style Building



Building Completed

Maintenance and Care

Annually or more often, the unit should be completely inspected internally and externally to make certain the unit remains properly installed and secured. Particular attention should be paid to:

Hardware ?check all carriage bolts and hardware connectors to be certain they are in place and tightened.

Base Plate Anchors ?during normal weather trends, the unit will strain against the base plate anchors under windy conditions. Anchor hardware connection to frame members should be maintained tight and depth of anchors should be checked to be certain they remain deeply and firmly set.

Snow Accumulation ?All snow accumulation on the main cover should be removed as soon as possible. Tap the main cover from the inside with a broom or soft brush to clear cover.

Main Cover Lacing ?the poly rope that secures the main cover to the bottom rail of the frame assembly should be checked, and adjusted as needed. The tension on the main cover should be uniform from end to end and side to side. Rope ends must be tied off onto the frame members at the ends on each side.

Cleaning ?cover and doors can be cleaned with a mixture of light detergent and water. A soft bristle brush with the mixture can be used to loosen any hard dirt, mold, or buildup on the cover. After cleansing, the cover

Major assembly steps are now complete. Go over entire building and re-tighten hardware, adjust ropes, and make certain all parts are in place and secured. Congratulations! The care and effort that was put into erecting this MDM Portable Building will be reflected in years of use and good service.

should be rinsed thoroughly to avoid any chemical reaction from residual detergent. Allowing dirt and debris to sit on cover over an extended time will damage cover irreparably.

Severe Weather ?in preparation for inclement weather, completely secure the door of your MDM Products portable building. Allowing wind to enter end lifts the building and puts undue stress on the anchoring system. This also shortens the life of the doors and main cover.

Customer Service or Installation Assistance

Care and attention to a proper installation will add many years of life and function to your MDM Products unit.

Please retain purchase documentation for your MDM Products unit. All warranty claims must include purchase documentation for verification. All parts on your MDM Products unit are available for replacement as needed. Protect your purchase by completing warranty registration card and mail/fax as soon as practical after installing your unit.

Thanks again for choosing this quality product. With proper operation and care we are confident it will meet your expectations in functionality, appearance and longevity.

Assembly Instructions Round Style 30x65x15-4 Industrial Round Style Building

INVENTORY CHART

Part List of WH306515RD-4		
Part Code	Description	Quantity
1	Top roof curved tube	17
2	Roof curved tube	30
2A	Roof curved tube in the front and back panel	4
3	Sidewall tube	30
3A	Sidewall tube on left of front and back panel	2
3B	Sidewall tube on right of front and back panel(connect the	2
4	Roof purlin and horizontal tube	75
4A	Longer Roof purlin and horizontal tube	5
5L	Base flange in corner	2
5R	Base flange in corner	2
6	Base flange for standing legs in the front and back panel	4
7	Base flange for sidewall	30
7A	Tie down ratchet	34
8L	Lower door track on left	2
8R	Lower door track on right	2
8L	Upper door track on left	2
9R	Upper door track on right	2
10	Upper beam of front panel	4
10A	Lower beam of front panel	2
11	Door beam	2
11A	Support tube for Deam Beam	2
11B	Splint plate for 11A	2
12	Bottom tensioning tube of front and back cover	4
13	Wind Brace Support	4
13A	Tube clip for wind brace support	8
14	Tensioning tube for lower roof cover	2
15	Door dropping tube in the middle	14
16	Metal plate for connecting upper and lower door track	8
17	Components for mechanical door	2
18	Steel wire for mechanical door	2
19	Auger	38
20	Duckbill	38
21	The U-bolt with plate and nut	38
22	The 36" drive rod	1
23	Carrige Bolt M10x80 for purlins connection	85
24	Hex Bolt M8x70 for arch tube connection	204
25	Hex Bolt M10x30 for wind brack and end panel tab	8
26	Hex Bolt M10x90 for end panel connection	52
26A	Bolt M10x60 for part 11A	8
27	Band for tie down ratchet	34
28	Plastic cap for tensioning tube	12
29	Rope for fastening the two ends of roof cover, the	1
30	Wrench for earth auger	1
31	Roof cover	1
32	Side cover beside the door	2
33	Door cover	2
34	Lock for door	4