



30' x 30' x 15' Three Car Portable Building

Protect Your Investments from Inclement Weather & Sun Damage

MDM Products 30x30 Buildings provide the best in instant and portable protection for any purpose. Typical uses include contractor workshop areas, equipment/material storage, and temporary work areas. Excellent jobsite protection of equipment, and rain protection to increase productivity. The round style unit provides extra space along the sides of the enclosure, with maximum height near the center ridge. The pre-drilled frame is easily assembled with minimal handtools. No drilling or field cutting is required. All frame components are made from heavy galvanized materials. Main cover and doors are made from long life UV Resistant, Fire Retardant Polyethylene with woven backing. All fabric components feature heat-welded seam

construction. Unit features triple zipper doors on BOTH ENDS to allow access from either end, drive-through capability, and good ventilation. Each door contains a pocket for a rigid pole and grommets for securing them up during use. The long lasting cover design provides for run-off of rain or melting snow to avoid water getting in through the perimeter of the cover. Each unit comes equipped with a set of 14 duckbill earth anchors, with a 36" stainless steel tether, and drive rod, to secure the unit at all strategic points.

Exclusive Features

- Heavy-Duty Galvanized Finish on All Steel Frame Components
- Two (2) Triple Zipper Doors Standard
- Wind Brace Support on each Side
- Complete Anchoring System Included
- 10oz, CPAI-84 Polyethylene Fabric Backed Cover and Doors
- All Pre-Drilled, Easy Bolt Together Assembly

| | |
|------------------------|--|
| Nominal Size | 30' Wide x 30' Long x 15' High |
| Arches | Seven (7) on 60" spacing 2-3/8" diameter frame members |
| Standard End Door Size | 27' Wide x 10'2" High at edge triple zipper door each end |
| Colors | Exterior- green or grey Interior - bright white |

| | |
|-------------------------|---|
| Main Cover | UV protected 24 mil, fabric backed poly. 10 oz weight |
| Fire Retardant Standard | Main cover and doors meet CPAI-84 Section 5 |
| Anchors | Fourteen (14) 36" Anchors with U-bolts & drive rod |
| Shipping Weight | 1190 lbs. in nine (9) boxes shipped via motor freight |





THREE CAR PORTABLE BUILDING 30'x30'x15'



Consumer friendly packaging - Easy to handle 9 box shipment

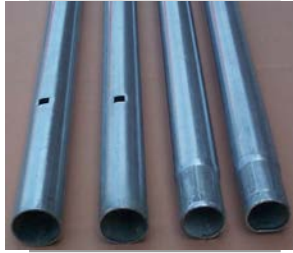

All frame members are long life galvanized steel



Structural wind brace on each corner



Heavy-Duty Cover lacing

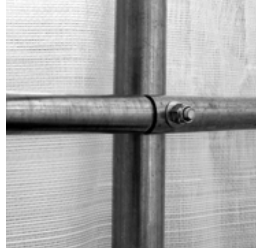

Pre-Drilled, Bolt together frame



Roll-Up Door Kit



Withstands winter weather



Heavy-Duty Anchors

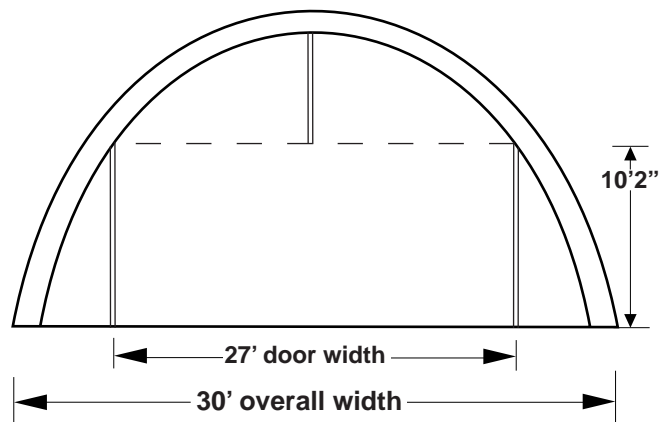
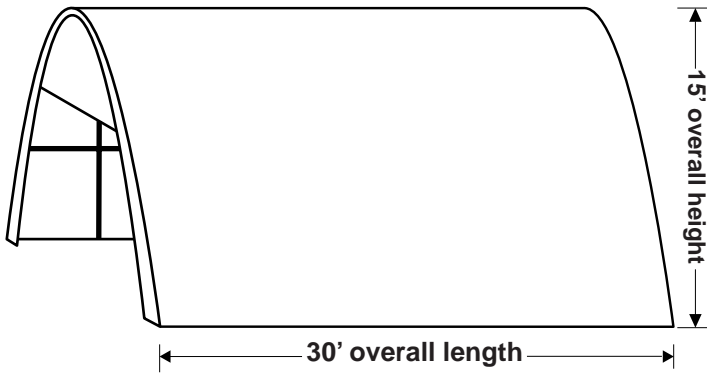

More Fine Products from *Rhino Shelter™*



One Car Garages



SUV/Boat Garages



Large Buildings



Two Car Garages

Car & Cycle Pockets



Party Tents 14' - 32' long



Spec 3Car
07/08



Check out the collection of covers world we offer.