

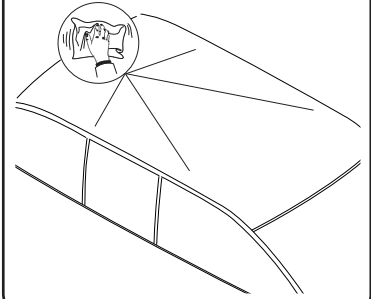

RHINO-RACK

Rhino Ski/ Snowboard Carrier 572, 573, 574, 576

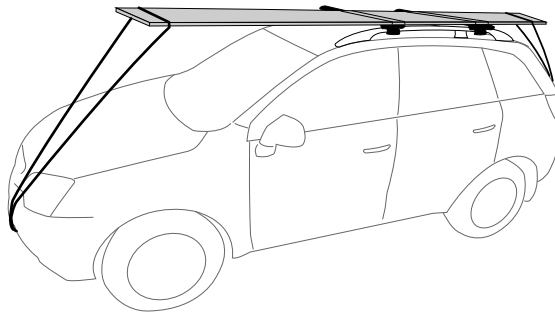
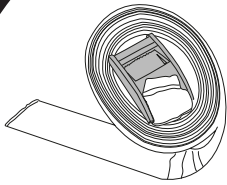
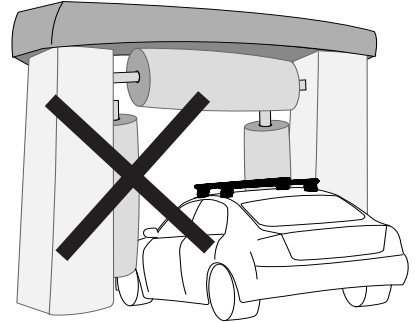
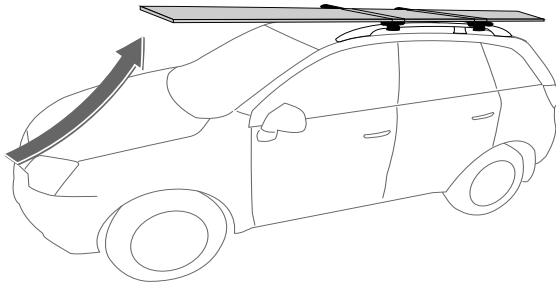

Important:

Please refer to your fitting instruction to ensure that the roof racks are installed in the correct locations. Check the contents of kit before commencing fitment and report any discrepancies. Place these instructions in the vehicle's glove box after installation is complete.

Maximum Load Capacity evenly distributed inside ski carriers:

6 Pair = 79lbs/36kg.

4 Pair = 53lbs/24kg.

2 Pair = 26lbs/12kg.

3 Pair = 39lbs/18kg.

Recommendations:

It is essential that all bolt connections be checked after driving a short distance when you first install your crossbars and accessories. Bolt connections should be checked again at regular intervals (probably once a week is enough, depending on road conditions, usage, loads and distances travelled). Please ensure that all loads are evenly distributed and that the centre of gravity is kept as low as possible. Make sure to fasten your load securely.

Use only non-stretch fastening ropes or straps.

Caution: The handling characteristics of the vehicle changes when you transport a load on the roof. For safety reasons we recommend you exercise extreme care when transporting wind-resistant loads. Special consideration must be taken into account when cornering and braking.

Please remove crossbars & accessories when putting vehicle through an automatic car wash.

Off-road use:

Ski/ Snowboard Carriers are not recommended for off-road use.

Note for Dealers and Fitters:

It is your responsibility to ensure instructions are given to the end user or client.



Rhino Ski Carrier 572, 573, 574, 576

Parts List

Item	Component Name	Qty	Part No.
1	Ski Carrier	2	-
2	Keys	4	-
3	M6 Spring Washer	4	W004
4	Top Clamp	4	M529
5	M6 x 40mm Security Screw	8	B085-BLK
6	M6 Flat Washer Black	8	W003-BLK
7	M6 Flat Washer Silver	4	W003
8	M6 Nut	8	N022-BLK
	M6 Tube Nut	4	N038
	Lower Clamp	4	M530
	M6 x 30mm T-Bolt	4	B183
	5mm Allen Key	1	H002
9	Instructions	1	R790

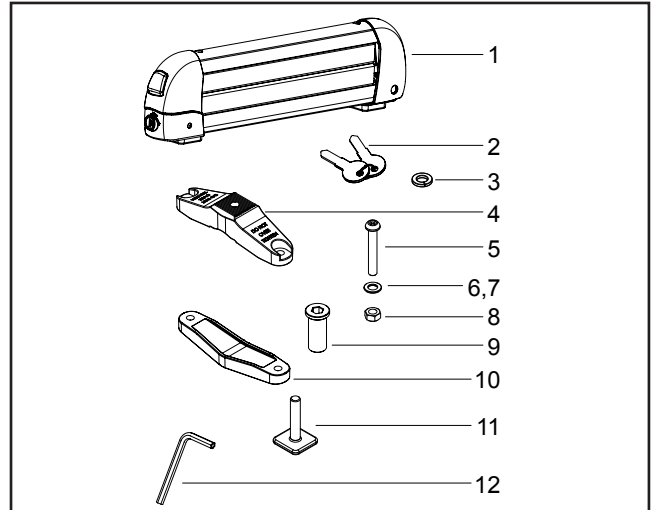

Tools Required:

5mm Security Allen key, provided in kit Tape measure.

Note:

When using round Yakima Crossbars, remove the Ski Carriers when not in use. It is possible the Ski Carrier could rotate in strong winds.

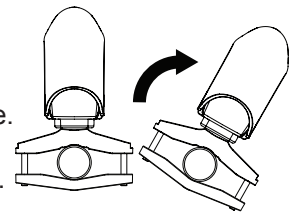

1

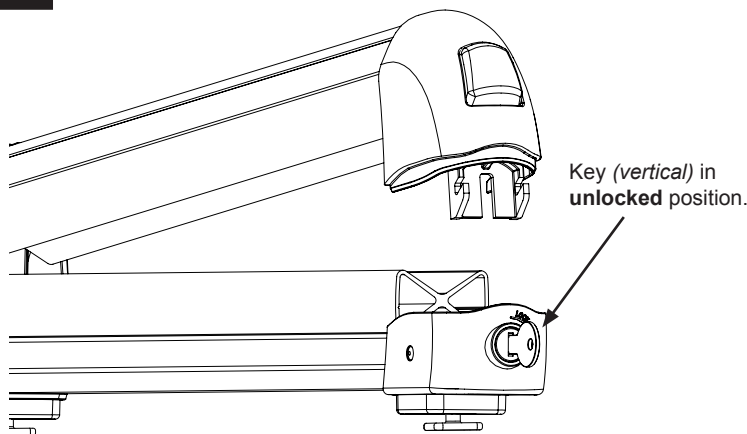

Open ski carrier.

Turn the **key anti-clockwise** to unlock ski carrier. Depress the button to open.

2

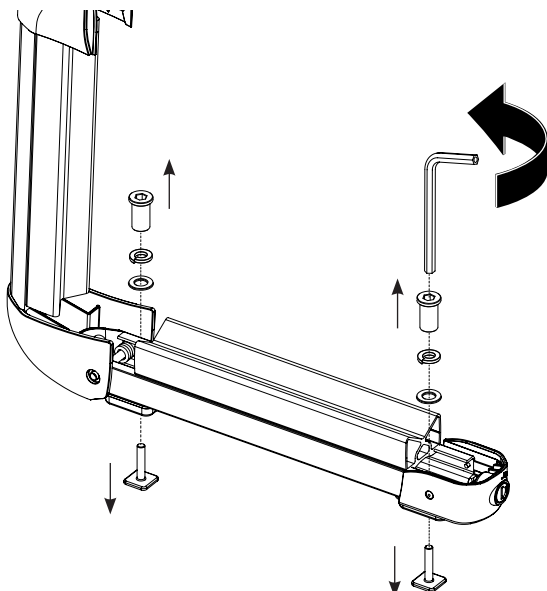

Remove hardware.

Remove tube nuts, washers and T-bolts.



Rhino Ski Carrier 572, 573, 574, 576

3

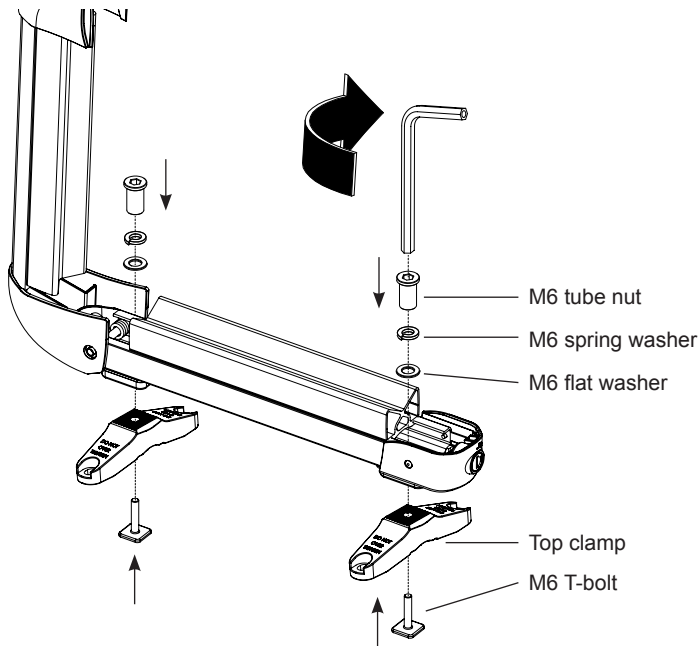

Attach top clamp.

Attach top clamp (M529). Fasten tube nut, washers and T-bolt as shown, 2-3 lb/ft (3-4 Nm).

4

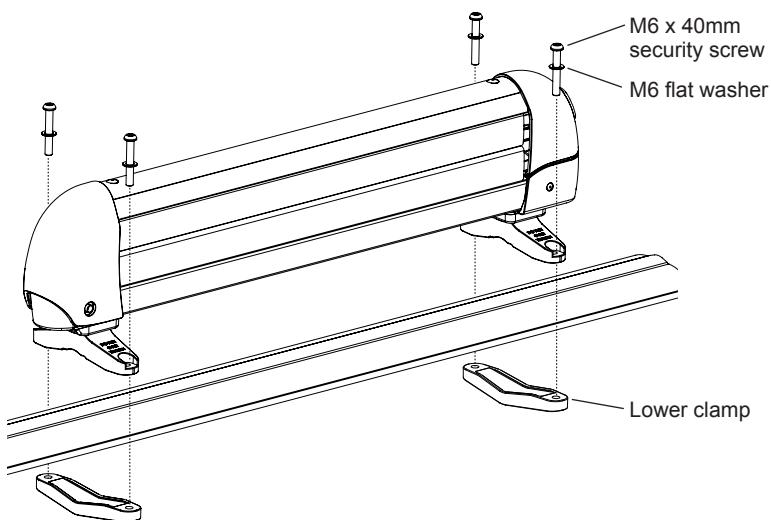

Attach to crossbars.

Attach ski carriers to crossbars using hardware supplied. Leave loose for adjustment.

5

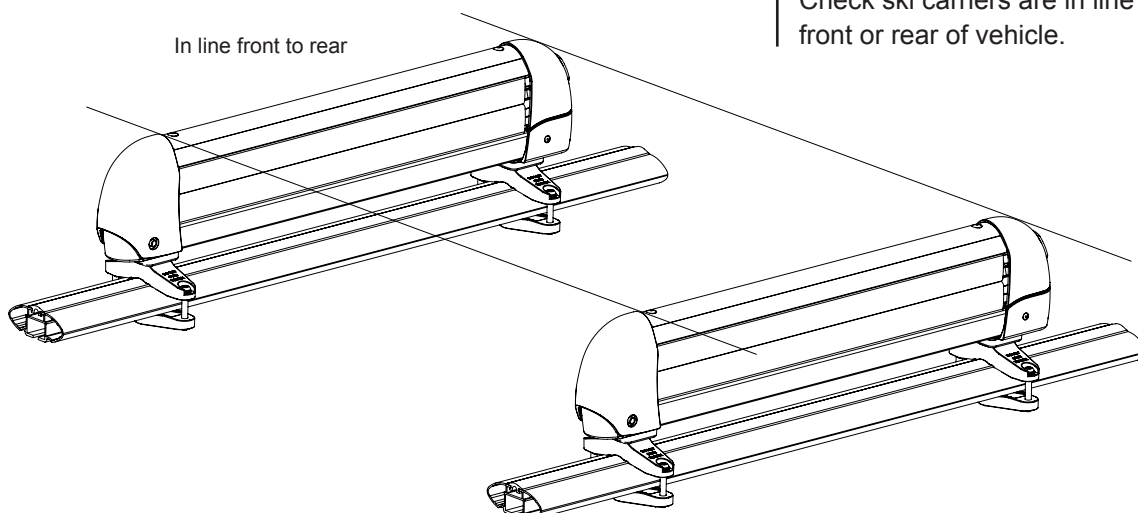

Position ski carriers.

Check ski carriers are in line when viewed from front or rear of vehicle.



Rhino Ski Carrier 572, 573, 574, 576

6

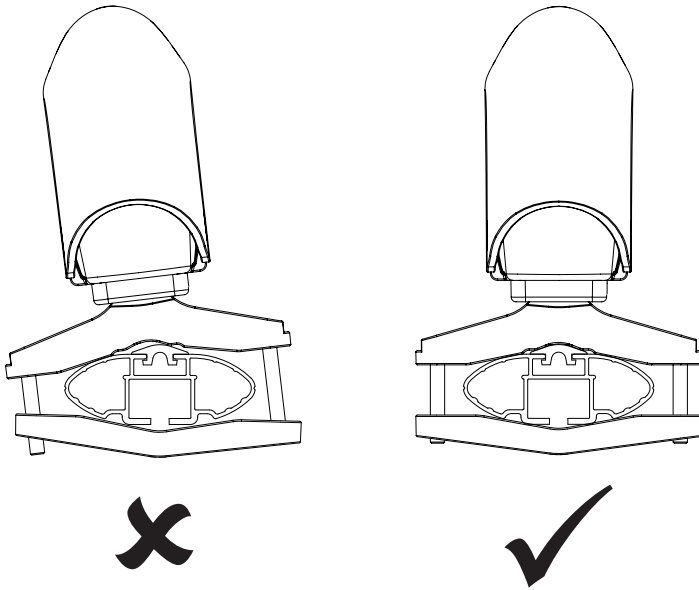

Fasten ski carriers.

Check ski carriers are sitting square to the crossbar. Tighten M6 screws on each clamp.

Tighten to 2-3 lb/ft (3-4 Nm).

DO NOT OVER TIGHTEN.

7

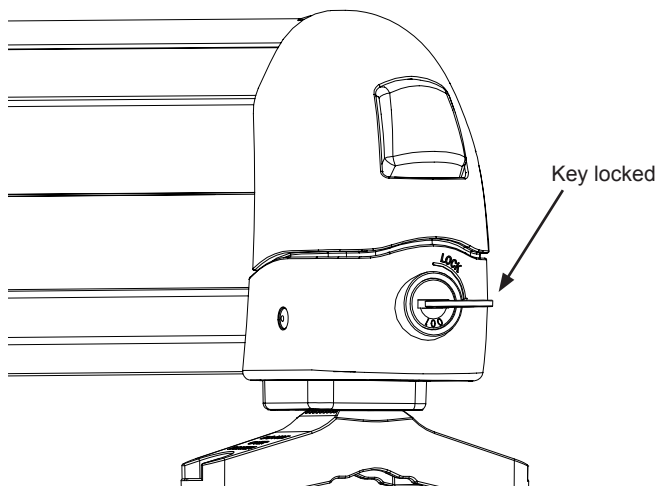

Locking the ski carrier.

Push top half down to clamp your skis until you here the **latch snap in place**. Turn key clockwise to lock. Remove key.

IMPORTANT: SKI CARRIER MUST ALWAYS BE LOCKED WHEN CLOSED.

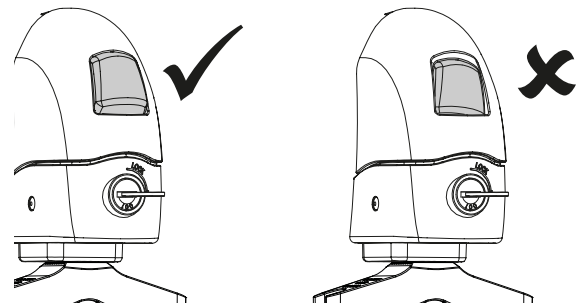

8

Transporting skis.

Ski carriers must be locked when transporting skis. Ski tips must face rearward.

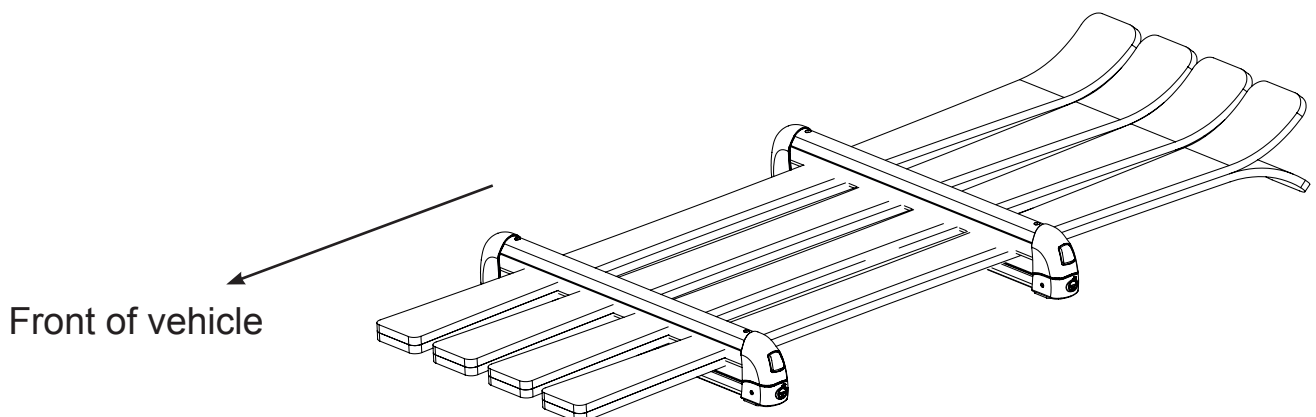



Rhino Ski Carrier 572, 573, 574, 576

Attaching Ski Carriers to C-groove of crossbar

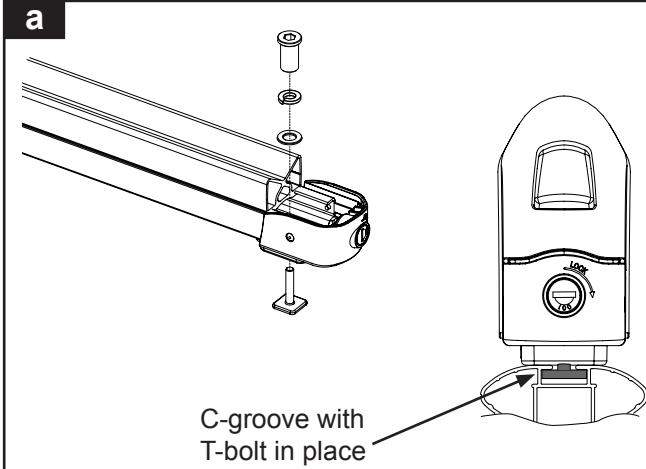

C-groove crossbars.

Remove rubber buffer strip.
Remove Top & Bottom clamp, refer Step 2.
Locate T-bolts in the C-groove by sliding the whole assembly into the top of the crossbar.

Position ski carriers in line as described in step 4.
Open ski carriers to tighten the M6 tube nuts, 2-3 lb/ft (3-4 Nm).

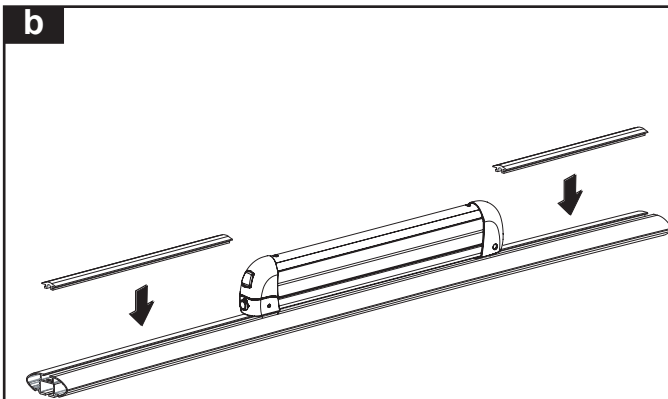

C-groove crossbars.

Measure and then cut the rubber strip to fill the gaps on either side of the ski carriers.