



RHINO-RACK

Aerodynamic & Heavy Duty Roof Rack Systems

SEG - Aero Ladder Slide

Place these instructions in the vehicle's glove box after installation is complete.

Important: Please read these instructions carefully prior to installation. Please refer to your fitting instruction to ensure that the roof racks are installed in the correct locations. Check the contents of this kit before commencing fitment and report any discrepancies.

Parts List

Item	Component Name	Qty	Part No.
1	Ladder Slide	2	M400
2	M6 x 16mm T-Bolt	2	B089
3	Sportz T-Bolt Tab	2	M086
4	M6 x 16mm Flat Washer	2	W031
5	M6 Nyloc Nut	2	N013
6	Fitting Instructions	1	RS-349

Tools Required

10mm Socket & Ratchet

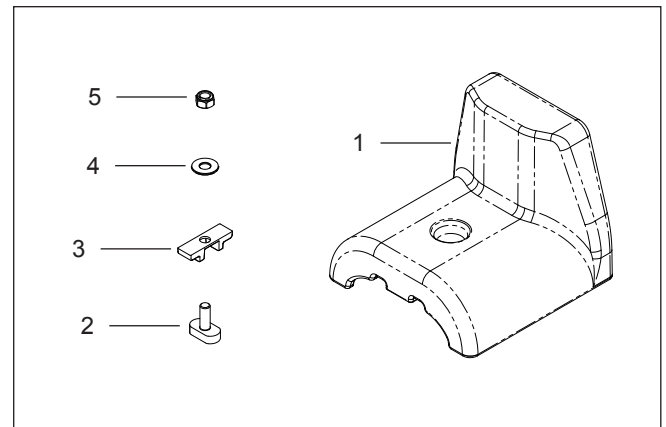

Fitment

Remove the buffer strip from the crossbar.

Lower the T-Bolt into the 'C' Channel as indicated and rotate the Bolt 90 degrees so it engages with the channel. Then lower the T-Bolt Tab over the bolt, this should stop the Bolt from rotating.

Place the ladder slide over the T-bolt and fasten in position with supplied hardware. You will need to tighten the nut with a 10mm socket and ratchet.

Repeat this process for the second slide making sure that the slides are facing each other with end posts to the outside.

Cut the buffer strip to the right size and replace in the crossbar. The buffer strip should sit up against the Easy Glide Pad on both sides.

