



RHINO-RACK

43107 Rhino Jerry Can Holder 43108 Rhino Jerry Can Holder - Horizontal

Important: Please read these instructions carefully prior to installation.
Check the contents of kit before commencing fitment and report any discrepancies.
Clean the alloy tray prior to installation.
Place these instructions in the vehicle's glove box after installation is complete.

Layout

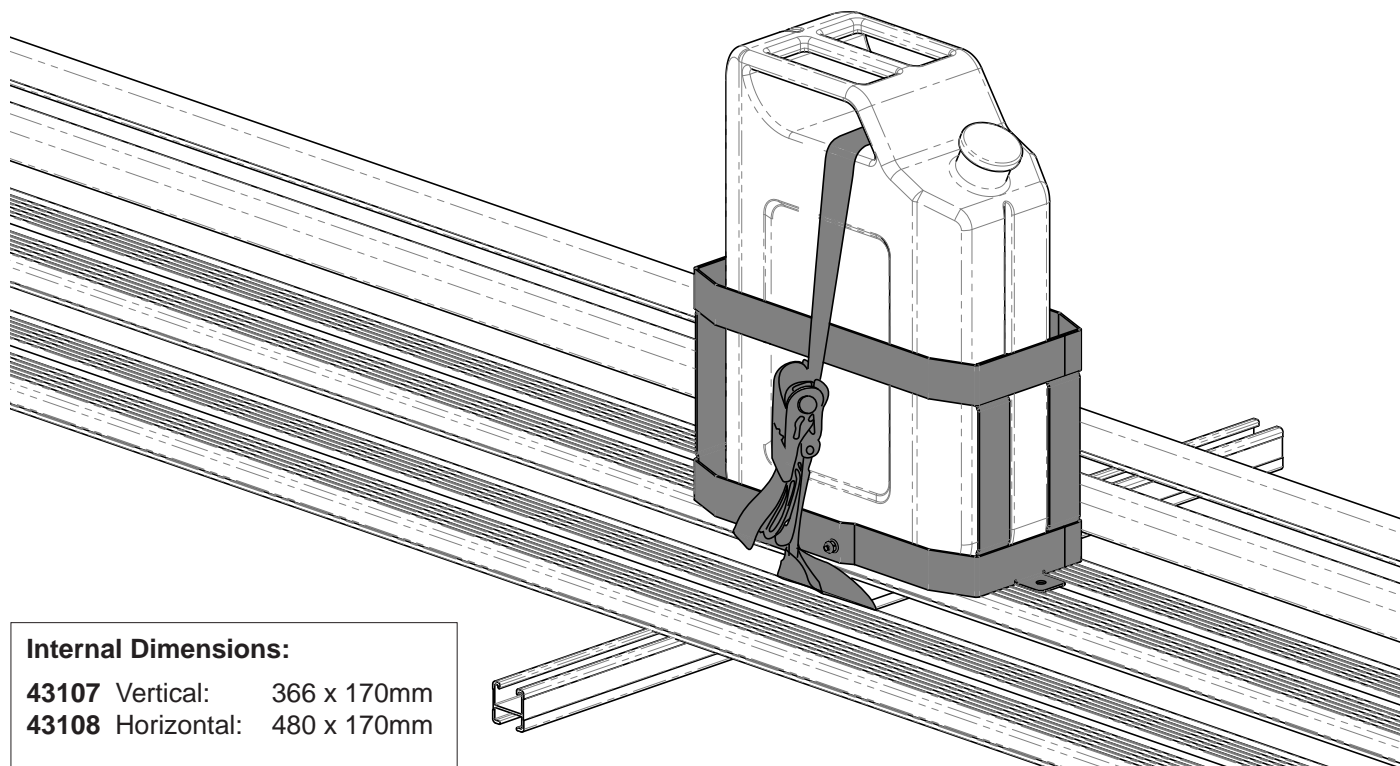

Internal Dimensions:

43107 Vertical: 366 x 170mm
43108 Horizontal: 480 x 170mm

Important Information

Recommendations:

Use only non-stretch fastening ropes or straps. Do not overload your Rhino-Rack Alloy Tray and roof bars. Check your vehicle's roof carrying capacity. Exercise caution when driving off road as vehicle roof height has been increased.

Caution:

The handling characteristics of the vehicle change when you transport a load on the roof. For safety reasons, we recommend exercising extreme care when transporting large wind-resisting loads; special consideration must be taken into account when negotiating corners and under braking.



43107 Rhino Jerry Can Holder

43108 Rhino Jerry Can Holder - Horizontal

Parts List

Item	Component Name	Part No.	Qty.
1	Jerry Can Holder	C693	1
1	Jerry Can Holder - Horizontal	C694	
2	Stainless Steel Ratchet 25mm	CA1133	1
3	Mount Bracket Left	C695	1
4	Mount Bracket Right	C696	1
5	M10 x 40mm Hex Bolt	B006	1
6	M10 x 25mm Hex Bolt	B071	1
7	M10 Shakeproof Washer	W021	1
8	M10 x 30mm Flat Washer	W023	1
9	M10 Channel Nut	N024	1
10	M8 x 16mm Hex Bolt	B019	2
11	M8 Spring Washer	W019	2
12	M8 x 17mm Flat Washer	W020	2
13	M8 Channel Nut	N003	2
14	M6 x 16mm Hex Bolt	B168	4
15	M6 x 12.5mm Flat Washer	W003	8
16	M6 Nyloc Nut	N013	4
17	Fitting Instructions	RS-242	1

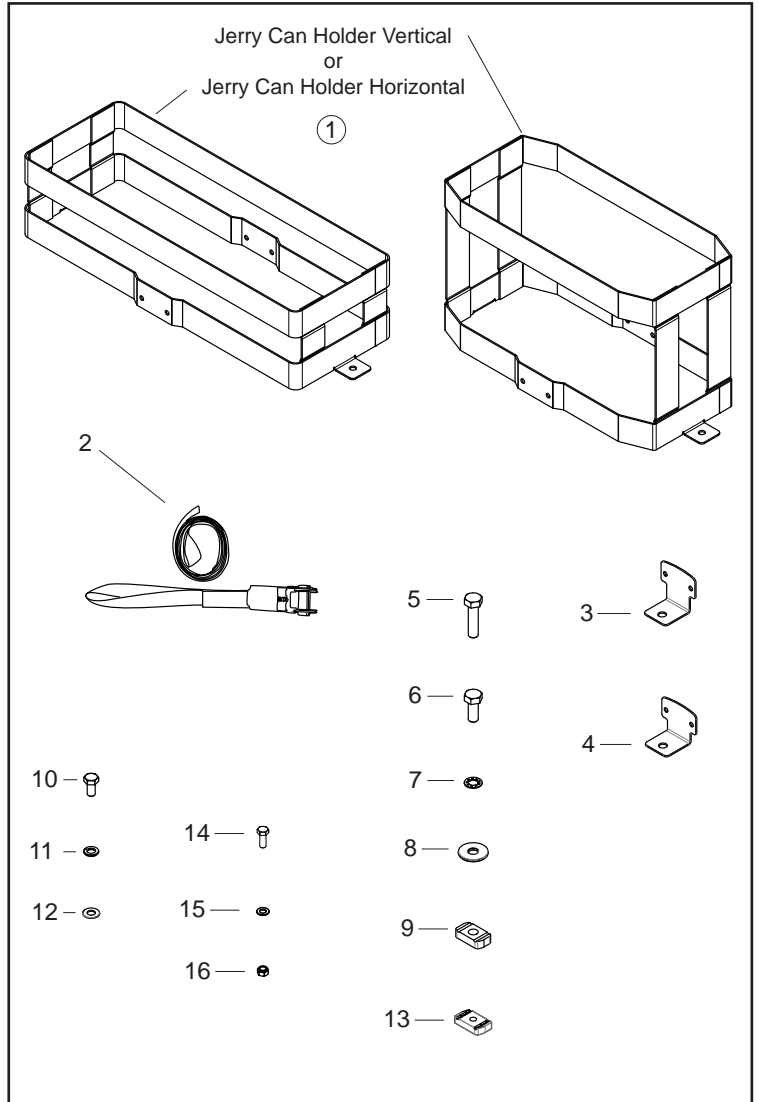

Tools Required:

16mm Spanner 13mm Spanner
 10mm Spanner Screwdriver

Rhino Alloy Tray Fitment Proceed to Step 1.

Rhino Pioneer Alloy Tray Fitment Proceed to Step 5.

1 Fit Mount Brackets:

Place the jerry can holder up-side down on your work bench. Proceed to fit the left and right mount brackets with the hardware supplied as shown below.

M6 Nyloc Nut

M6 x 12.5mm Flat Washer

M6 x 12.5mm Flat Washer

M6 x 16mm Hex Bolt

Brackets fitted to inside



43107 Rhino Jerry Can Holder

43108 Rhino Jerry Can Holder - Horizontal

2 Fit Hardware to Jerry Can Holder:

Fit hardware to the long mount bracket on the jerry can holder as shown, leave the hardware loose at this stage.

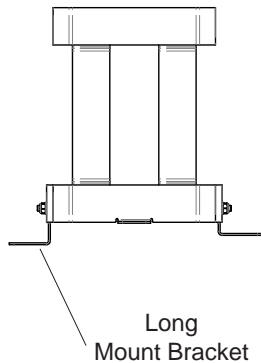

M10 x 25mm Hex Bolt
M10 Shakeproof Washer
M10 x 30mm Flat Washer

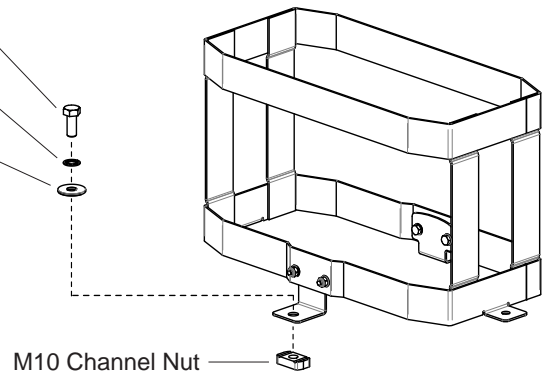

3 Remove Eye Bolt:

Decide which corner you would like the jerry can to be located on the alloy tray. Remove the eye nut in this location with the shank of a screwdriver. Remove the shakeproof and flat washer below the eye nut on the alloy tray.

Please Note:

If the existing bolt is M10 x 35mm replace it with the M10 x 40mm bolt provided, you will have to remove more eye nuts and loosen some allen key bolts to slide the bolt and tab cage in and out of the bar.

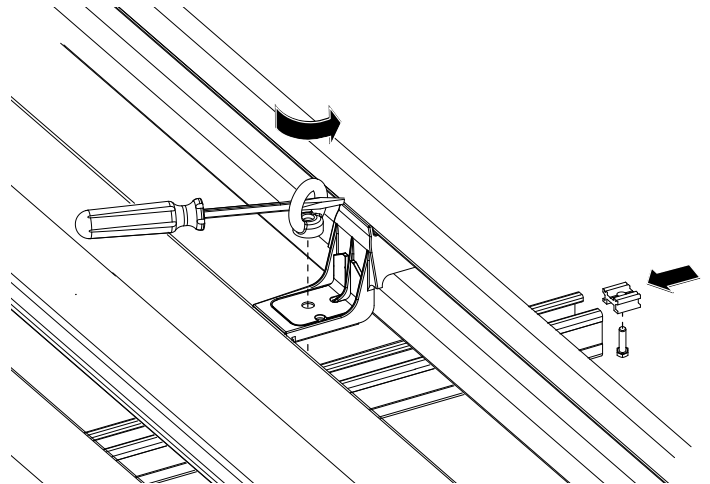

4 Fit Jerry Can Holder to Tray:

Lower the jerry can holder onto the tray making sure that the bolt in the tray goes through the hole in the mount bracket.

Fit the eye bolt and washers as shown. On the opposite side make sure that the channel nut rotates 90° when inserted into the commercial bar.

Tighten the M10 bolt with a spanner. Tighten the eye nut with the shank of a screwdriver as shown below.

Proceed to Step 6.

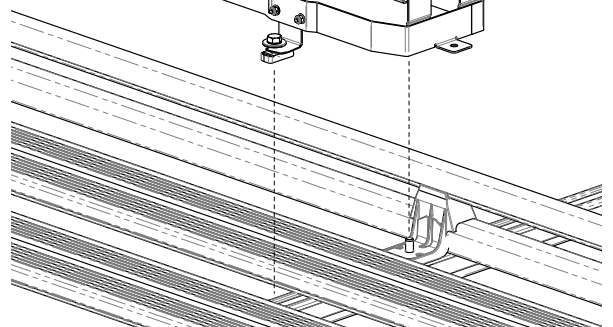
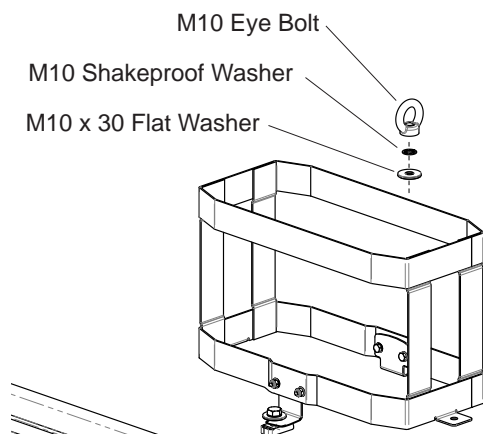
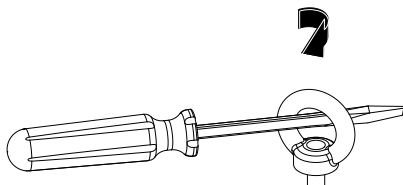



43107 Rhino Jerry Can Holder

43108 Rhino Jerry Can Holder - Horizontal

Rhino Pioneer Alloy Tray Fitment

5 Fit Jerry Can Holder to Plank:

Lower the jerry can holder onto the plank where you would like to fit the unit. Place two M8 channel nuts into the slot at the end of the plank and slide the channel nuts under the tabs at each end of the jerry can holder. Fit the hardware to the channel nuts as shown and fasten in position.

Fitment Note: Jerry can holder must always be fitted to the outside plank of the tray. It must also be centred over one of crossbars running beneath the planks as the strap brackets need to be fitted to the crossbar.

Multiple Jerry Can Holders: When fitting multiple jerry can holders to the same tray the load must be distributed evenly over the tray. Fitment note above must also be followed.

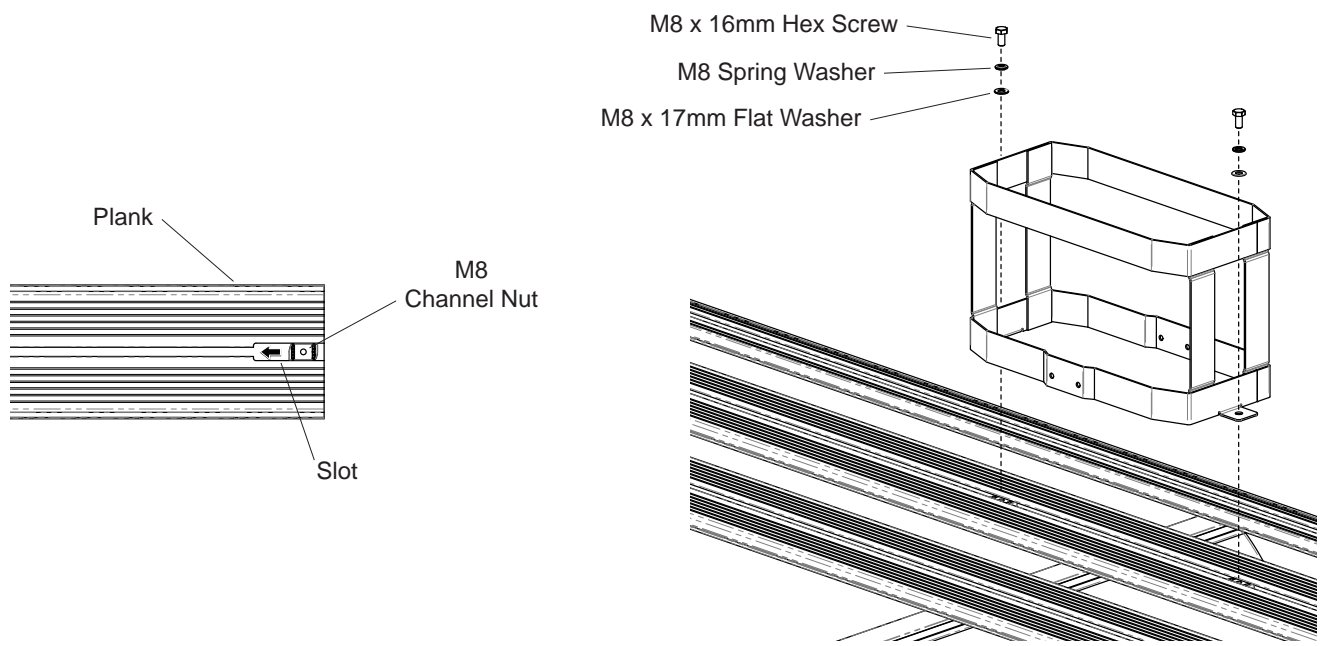

6 Insert Jerry Can:

Insert the jerry can to be used into the jerry can holder as shown below.

Horizontal Jerry Can Holder

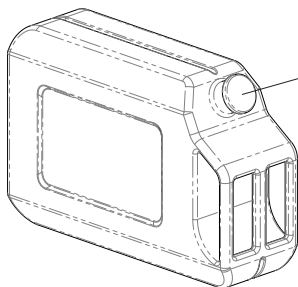

It is important to keep the filler cap facing upwards when you load the jerry can into the holder.

Vertical Jerry Can Holder

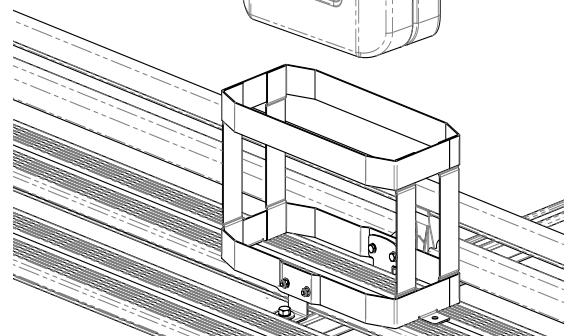
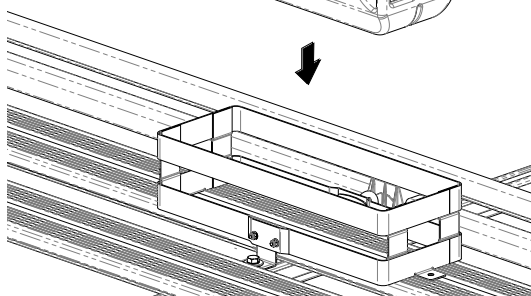
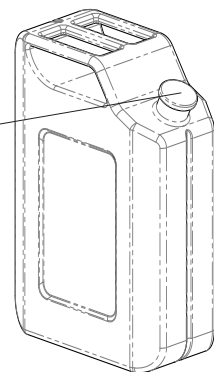



43107 Rhino Jerry Can Holder

43108 Rhino Jerry Can Holder - Horizontal

7 Fit Ratchet Strap:

Horizontal Holder:

Lay the ratchet strap over the middle of the jerry can holder as shown. Wrap the ratchet end of the strap under the crossbar and feed through the loop, gently pull the ratchet until the strap is firmly in place. Repeat this for the opposite side, ensure that the strap is kept as close to the jerry can holder as possible.

Tighten the ratchet strap until the jerry can is secure.

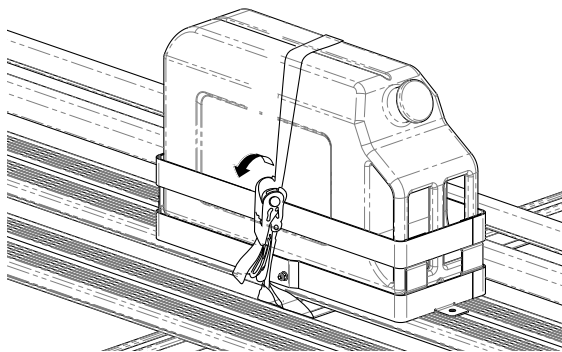

Vertical Holder:

Insert the ratchet strap through the handle of the jerry can as shown. Wrap the ratchet end of the strap under the crossbar and feed through the loop, gently pull the ratchet until the strap is firmly in place. Repeat this for the opposite side, ensure that the strap is kept as close to the jerry can holder as possible.

Tighten the ratchet strap until the jerry can is secure.

