

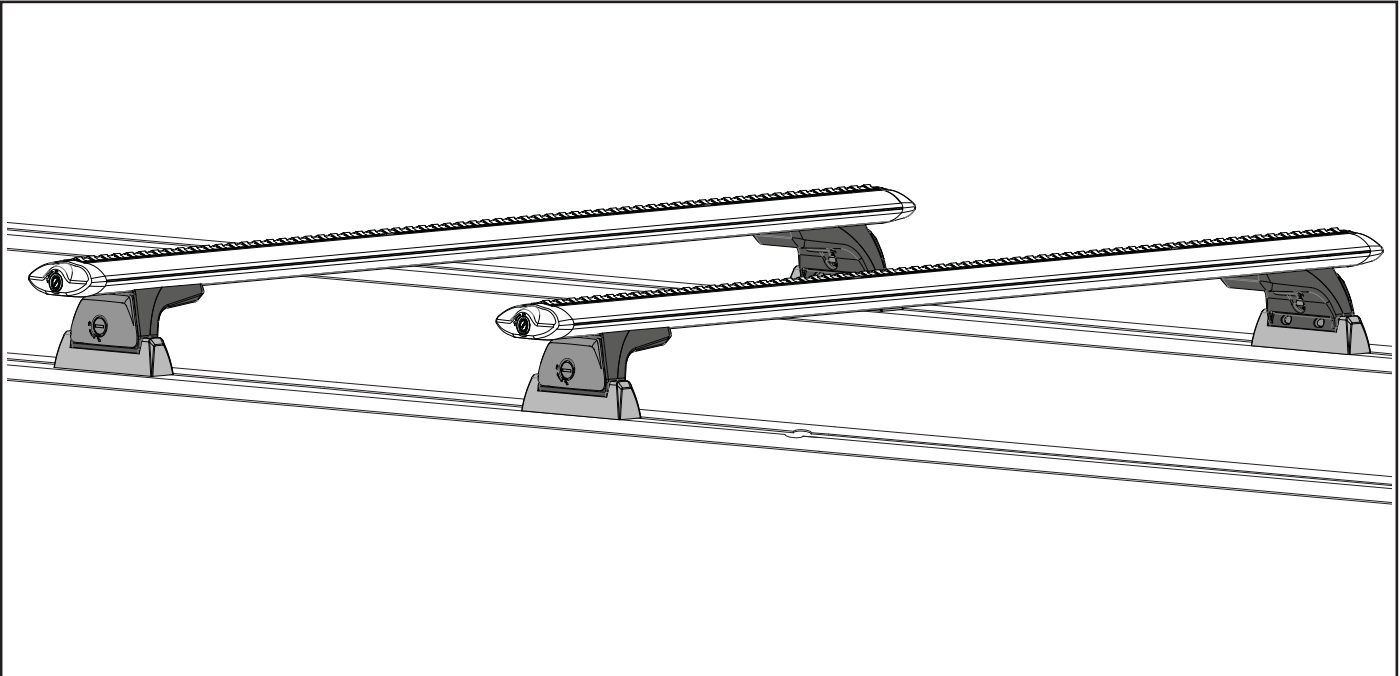

RHINO-RACK

Quick Mount Track Legs RLT600

Important: Please read these instructions carefully prior to and during installation.
Check the contents of kit before commencing f tment and report any discrepancies.



Clean roof prior to installation.

Important Information

Maximum carrying capacity: Up to 100kg. Evenly distributed over the crossbars.

It is essential that all bolt connections be checked after driving a short distance when you f rst install your crossbars. Bolt connections should be checked again at regular intervals (probably once a week is enough, depending on road conditions, usage, loads and distances travelled). You should also check the crossbars each time they are re-f tted.

Make sure to fasten your load securely. Ensure all loads are evenly distributed and centre of gravity is kept as low as possible.

Use only non-stretch fastening ropes or straps.

Caution: The handling characteristics of the vehicle changes when you transport a load on the roof. For safety reasons we recommend you exercise extreme care when transporting wind-resistant loads. Special consideration must be taken into account when cornering and braking.

Please remove crossbars when putting vehicle through an automatic car wash.

Load ratings:

Maximum permissible load for system is up to 100kg per pair of crossbars. When crossbars are to be used in off-road conditions, please build a safety factor of 1.5 into this load limit. Although the crossbars are tested and approved to AS1235-2000, off-road conditions can be much more rigorous. However, increasing the number of crossbars does not increase the vehicles maximum permissible roof loading.

Please refer to your vehicle manufacturers handbook for the maximum roof loading allowable for your make and model vehicle. Always use the lower of the two figures



Quick Mount Track Legs RLT600

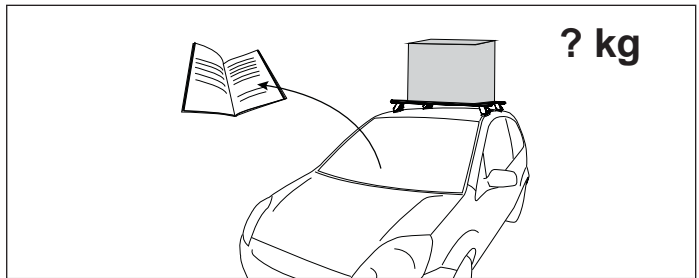
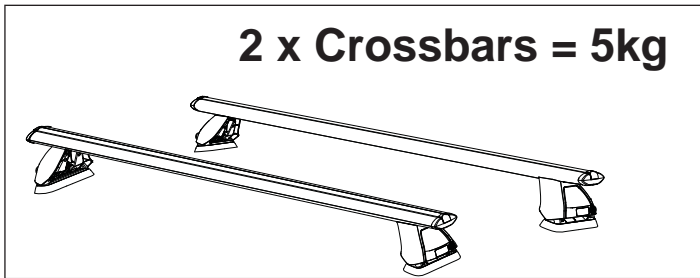
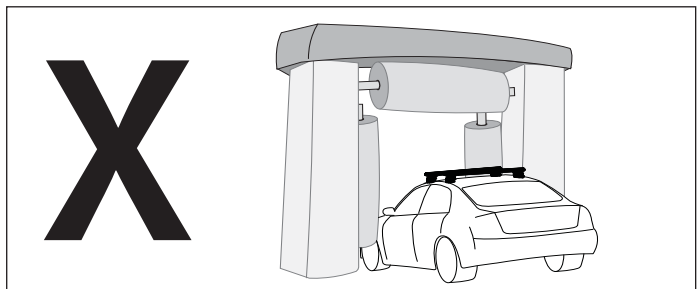
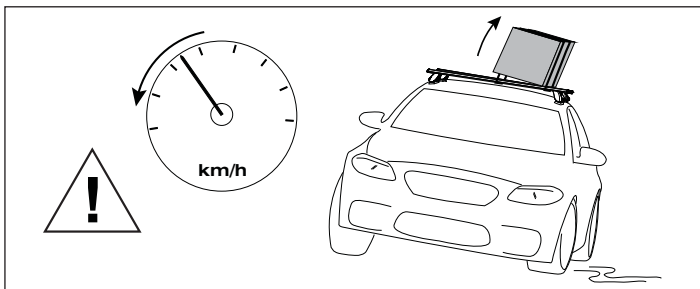
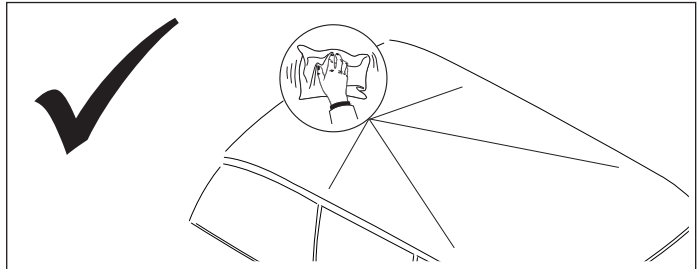
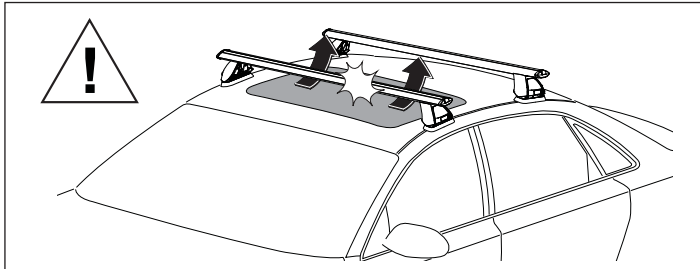
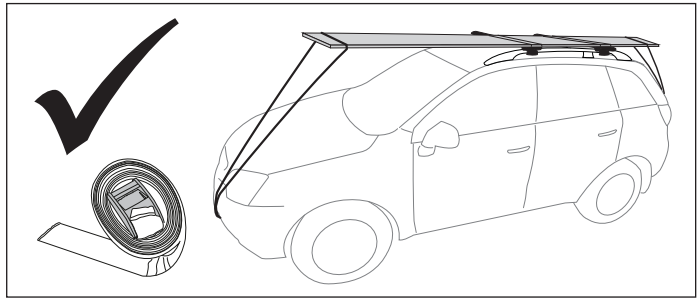
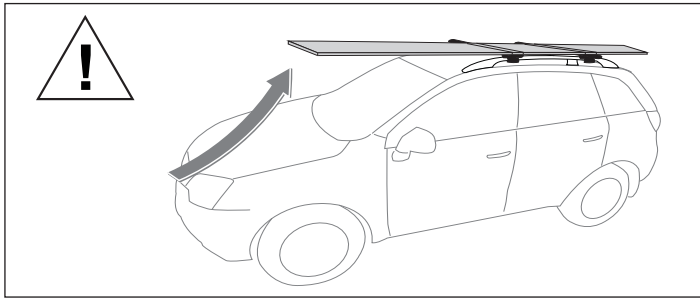

When these roof racks are to be used on a vehicle that is driven off sealed roads, the manufacturer maximum roof load rating (to be found in the vehicles User Manual) should be **divided by 1.5**. Do not forget to subtract 5kg from your maximum carrying capacity due to the weight of the crossbars and legs.

100kg load rating (Urban road)	=	67 kg load rating (Off road - 50kg / 1.5)
-----------------------------------	---	--

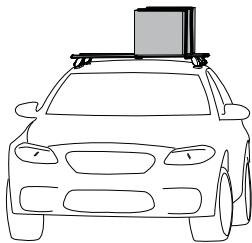
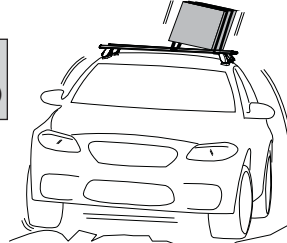
WARNING! Important Load Carrying Instructions

With utility vehicles, the cabin and the canopy move independently. Roof racks and vehicle can be damaged if the item transported is rigidly fixed at points on both the cabin and canopy. Instead, rigidly fix to either the cabin roof racks or the canopy roof racks.

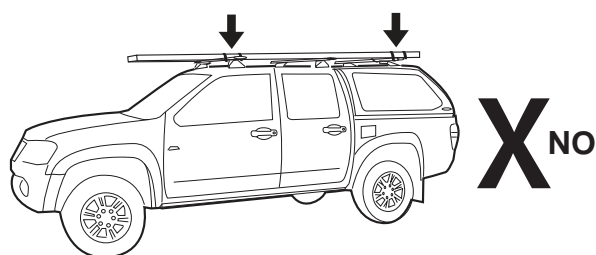
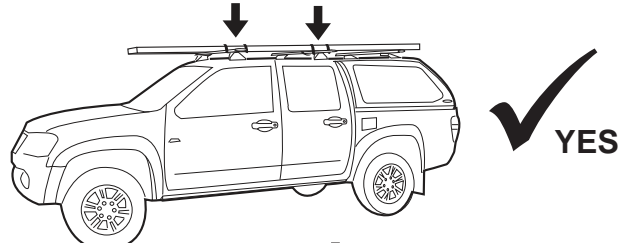
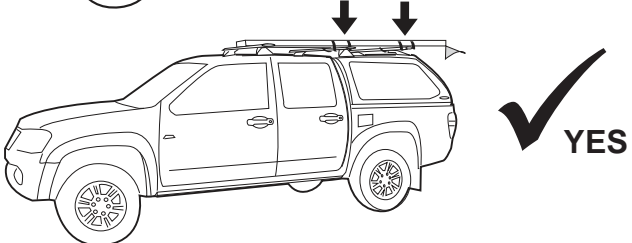

Quick Mount Track Legs RLT600

Parts List

Item	Component Name	Qty	Part No.
1	M6 30x25x5 Nut	4	N035A
2	Track Leg Body	4	M703
3	M6x16x1.6 Flat Washer	4	W031
4	M6 Spring Washer	12	W004
5	M6x20 Socket HD	4	B054
6	Track Leg Base Cover	4	M702
7	Track Leg Base	4	M701
8	5mm Allen Key	1	H021
9	Track Leg Lockable Cover	4	M704
10	M6x16 Button Security Screw	8	B061
11	M6x12.5 Flat Washers	8	W003
12	M6 24x21x4 Nut	8	N057
13	Instructions	1	R474

Layout:

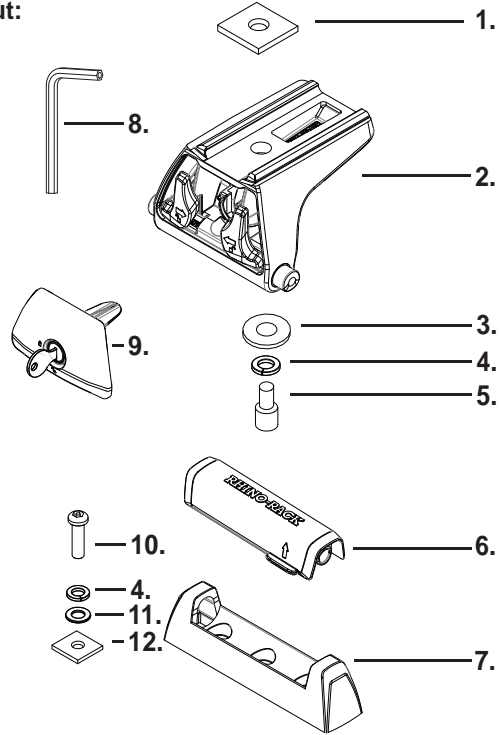

Tools Required: Allen Key (provided)
Metal Key (provided)

Instructions

- 1** Place M6 24x21 Hex Nut into the opening of each track at rear of vehicle. Slide along the track to position. Take note that the number of nuts used is vehicle and track specific.

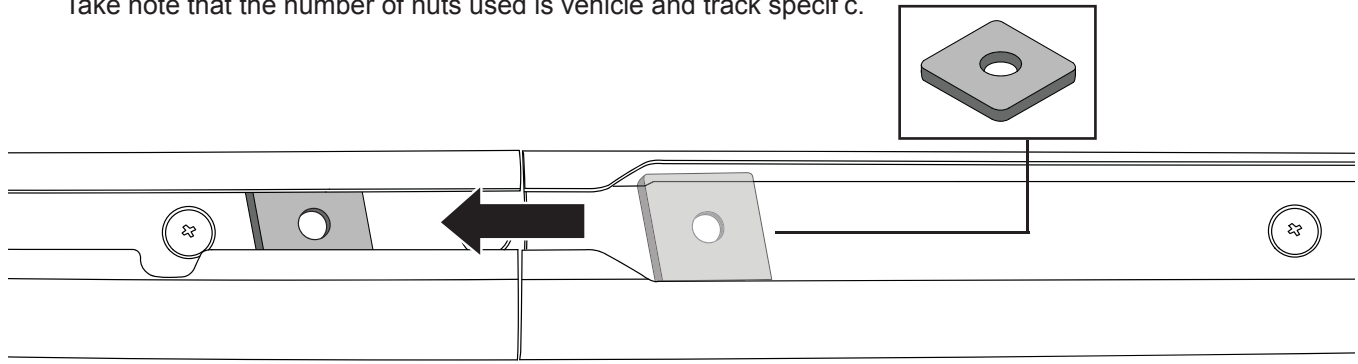

- 2** Place the mounting plate onto the track. Fix in place with security screws, spring and flat washers. Note that the amount of fixing hardware used is dependant on the previous step and vehicle requirements.

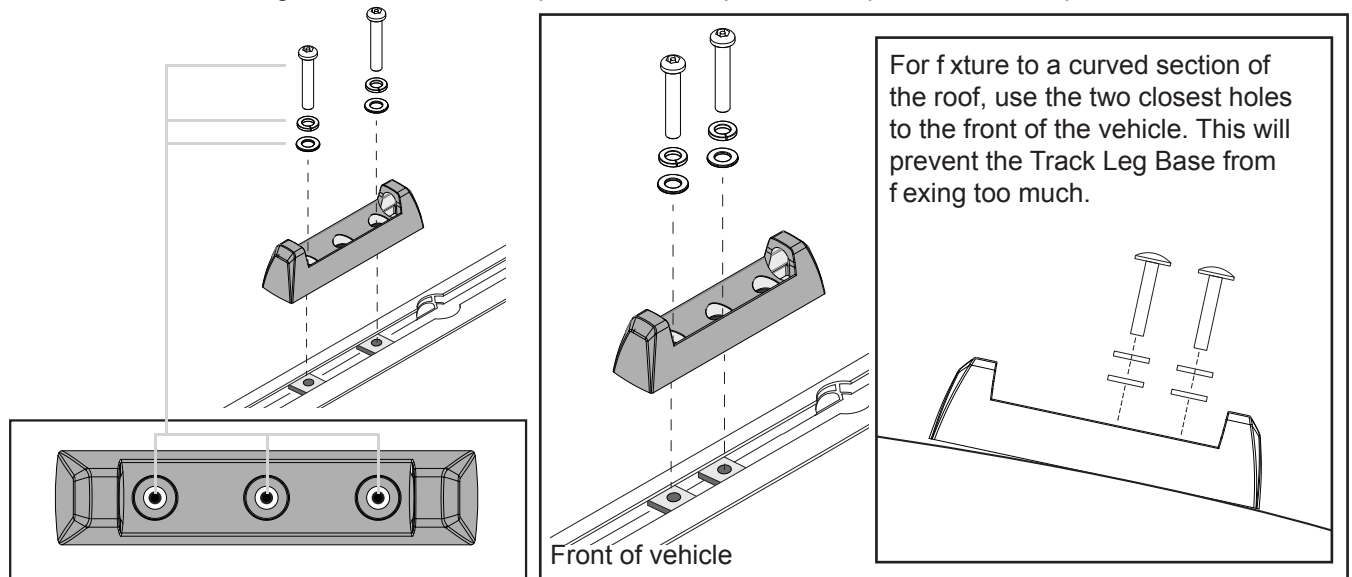



Quick Mount Track Legs RLT600

3 Prepare the Leg for installation as follows: 1 - Remove cover plate. 2 - Locate and Pinch locking levers together. 3 - With levers pinched together, push them backward into a locked position within the leg cavity.

1.

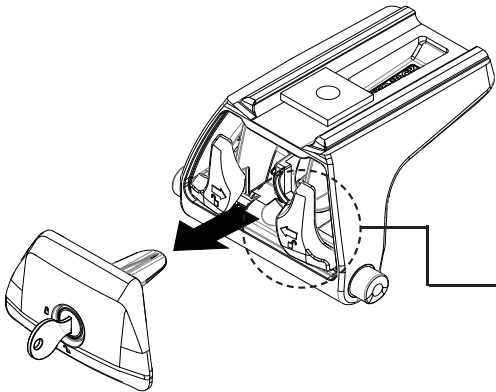

2.

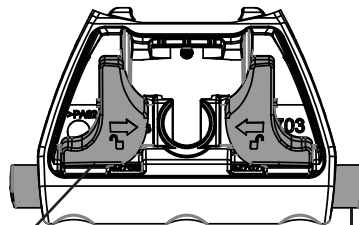

Note the locking studs extended. The Leg is now 'locked'.

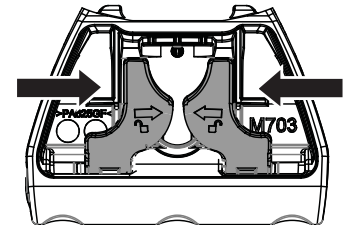

retracted 'unlocked'

3.

Keep locking levers in position.

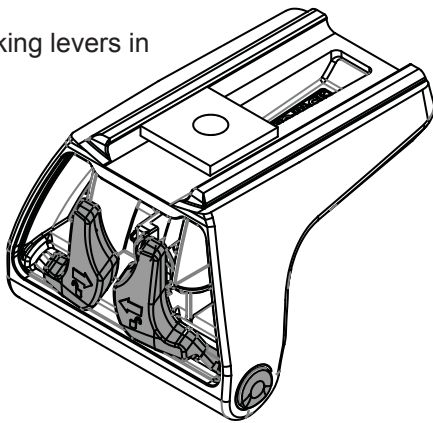

Push levers back into leg cavity to locate into an 'unlocked' position.

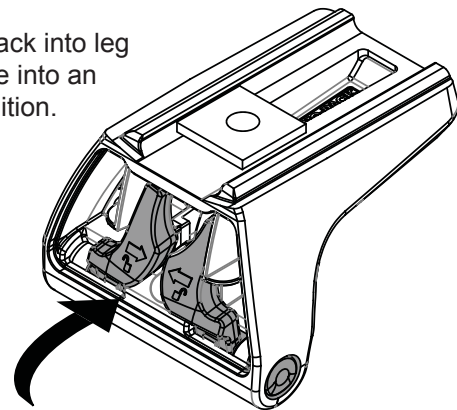

4 With the locking studs now in an 'unlocked' position, insert the leg into the mounting bracket.

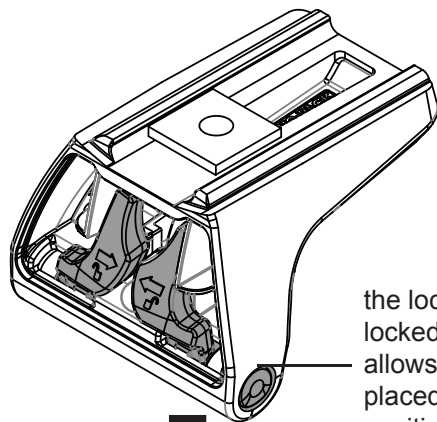

the locking studs are locked inward, this allows the leg to be placed in a mounting position.

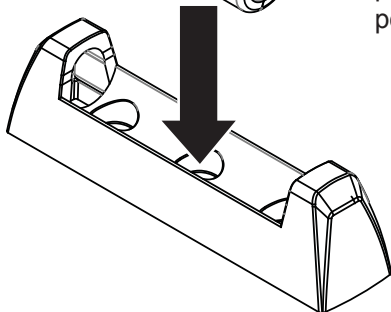

Front View

1.

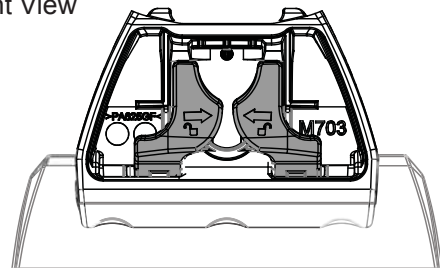

2.

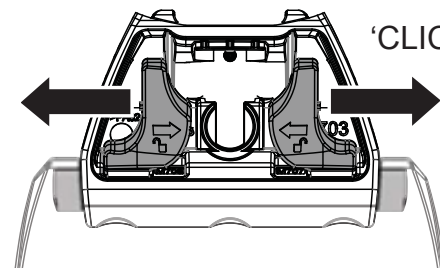

Pull the locking levers forward to their original position. They will spring back pushing the locking studs back outward, fixing the leg into the mount. Ensure both studs are secure in bracket. Apply small amounts of downward pressure if studs do not engage.



Quick Mount Track Legs RLT600

- 5** Assemble the leg hardware as shown. Slide the leg into the bar and finger tighten. Repeat for all 4 legs.

Note: Leg hardware comes pre-assembled.

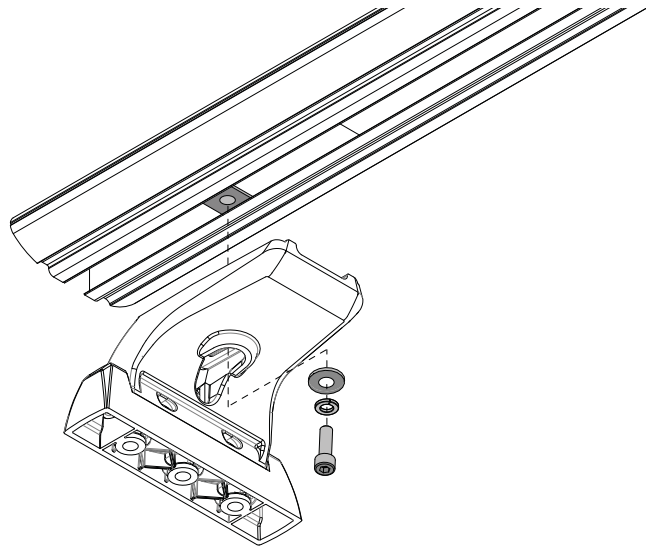
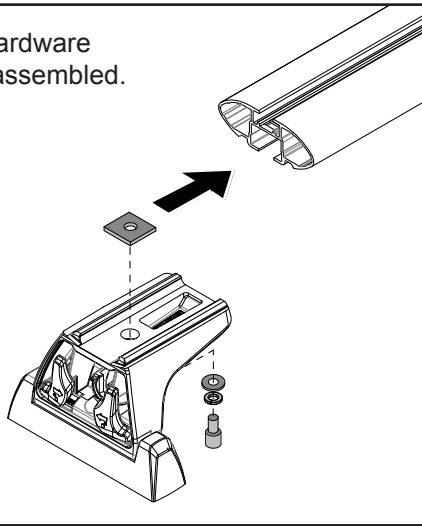

- 6** Check the cross bar overhang is equal on both sides, re-adjust if required. Tighten with a 5mm allen key.

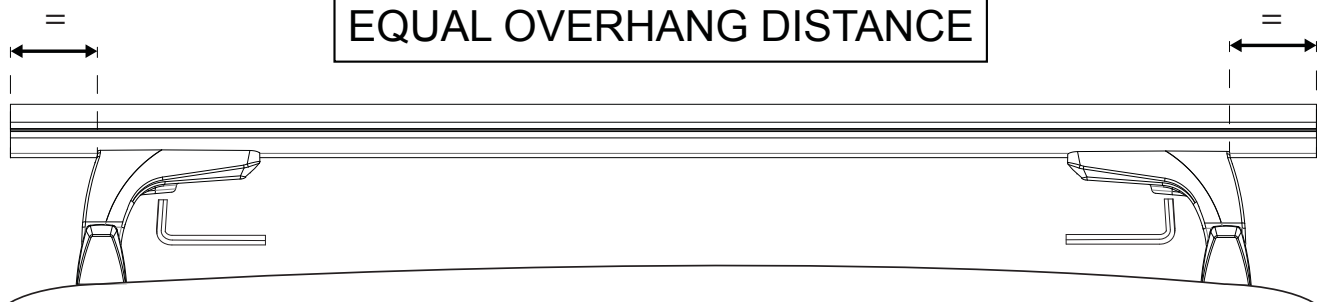

At this point the bar can be removed and the mounting base can be fully tightened if not done so in step 2.

- 7** Insert the Face plate into the leg. Using the key provided, insert and turn clockwise to lock the unit. Remove the key.

Insert the cover plate and then lock using the key provided in the kit. If it cannot be inserted properly it means one of the studs is not correctly fitted. Check fitment and re-try.

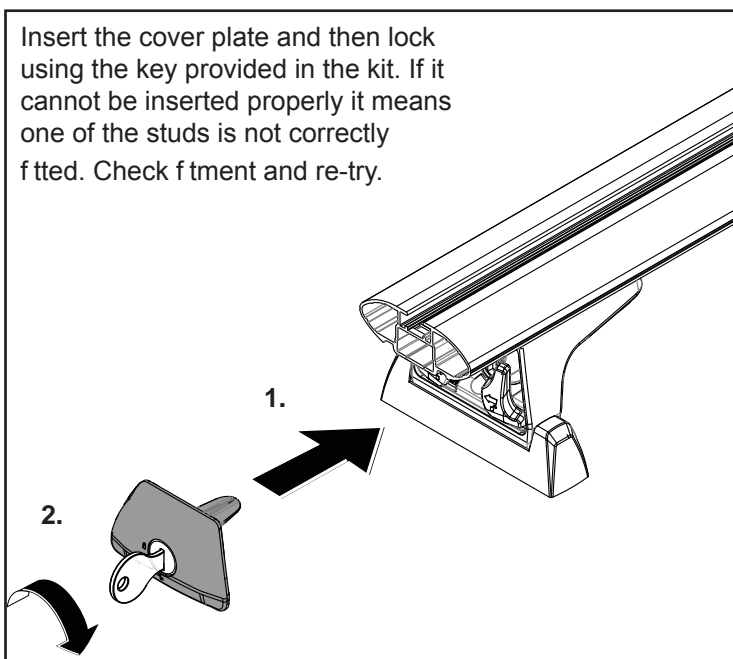

Note: The Face Plate will cover the hardware holding the legs in place. This will help to ensure your system is secure from theft.

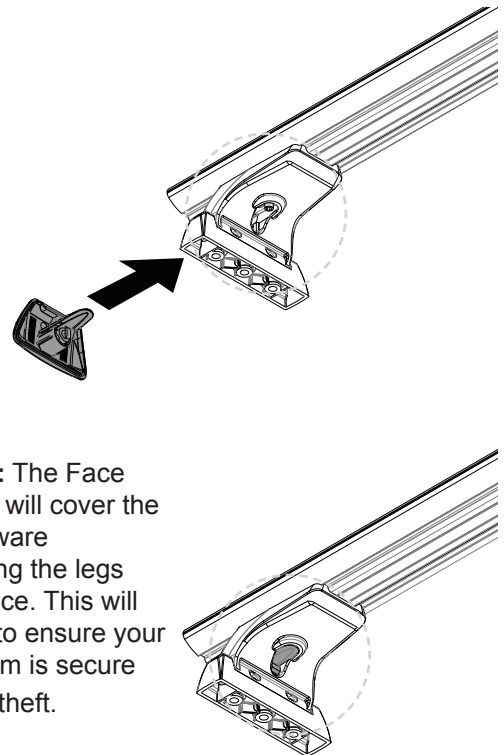



Quick Mount Track Legs RLT600

- 8** Install the Vortex Rubber Strips. It may be easier to remove bar and complete assembly steps 8,9 and 10.

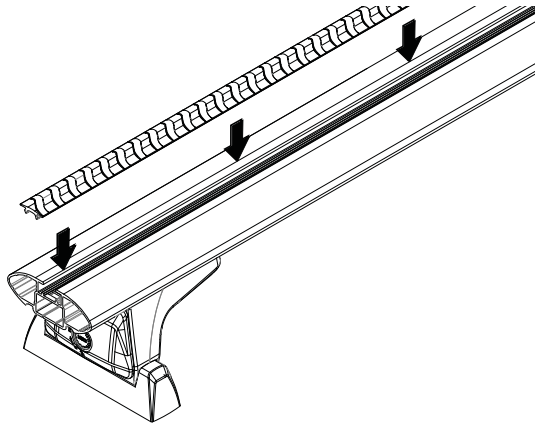

- 9** Insert the end cap. Using the key provided, lock the end cap. Remove the key. Note metal keys can be purchased so they match the RLT600 Leg.

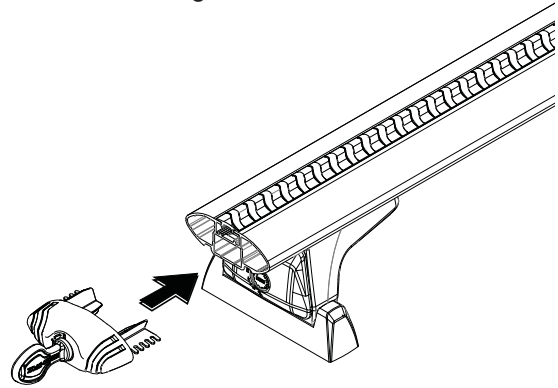

Removing the Bars

- 1** Remove the cover plate from the legs. Squeeze the locking levers together and push them backward into the leg cavity. Assistance may be required.

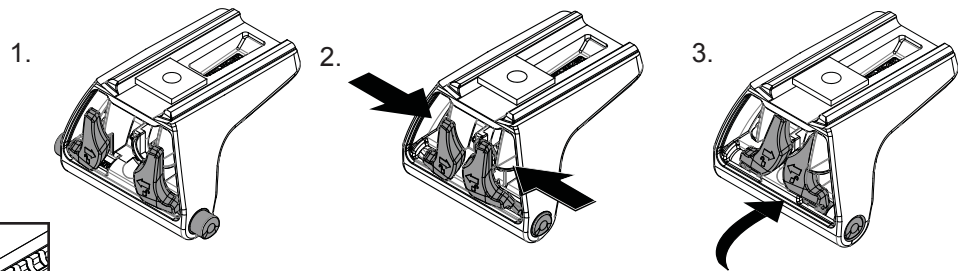

Remove the cover plate to access the locking levers.

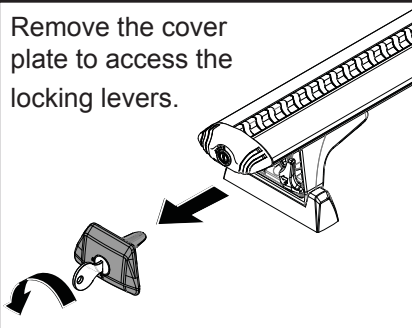

Note:
Use two hands to push in the locking levers if tight. Do not use a screw driver as this may damage the levers.

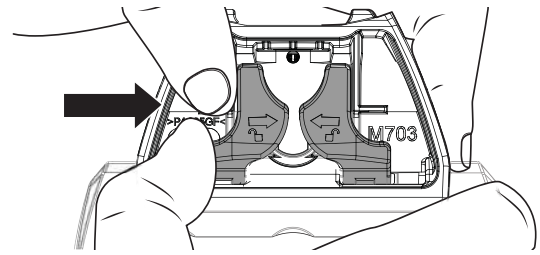

- 2** With assistance, carefully lift the bars out of the corresponding mounting plates.

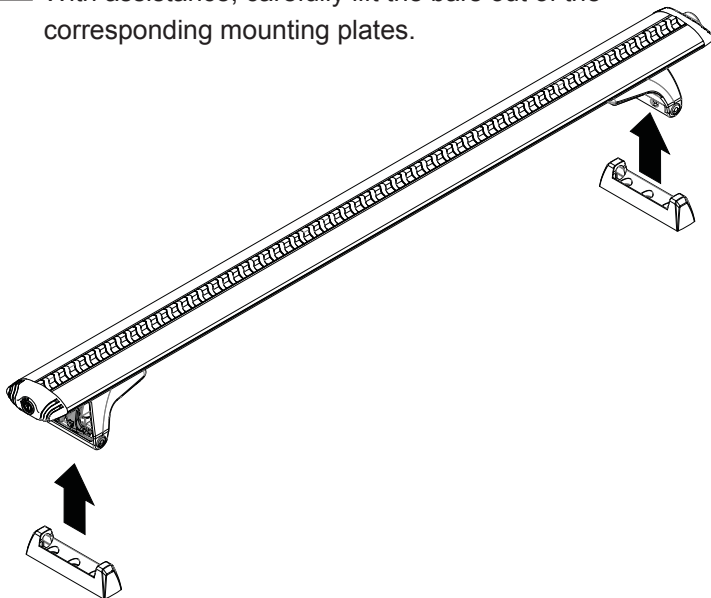

Attach Leg Base Cover when not in use.

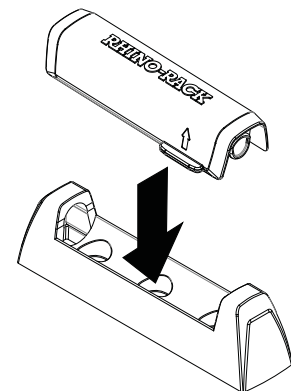



RHINO-RACK

RLCP Rhino Heavy Duty - Canopy / Hard Tonneau Track Mount

Important: Please read these instructions carefully prior to installation. Please refer to your fitting instruction to ensure that the roof racks are installed in the correct locations. Check the contents of kit before commencing fitment and report any discrepancies. Place these instructions in the vehicle's glove box after installation is complete.

Parts List

Maximum carrying capacity: Refer to manufactures specifications.

Item	Component Name	Qty	Part No
1	Heavy Duty Rubber Buffer Strip	2	R004
2	Heavy Duty End Cap	4	M002
3	Heavy Duty Crossbar	2	A020
4A	Knob and M6 & Nyloc Nut - 1200mm Track	12	M175N013
4B	Knob and M6 & Nyloc Nut - 1400mm Track	14	M175N013
4C	Knob and M6 & Nyloc Nut - 1600mm Track	16	M175N013
4D	Knob and M6 & Nyloc Nut - 1800mm Track	18	M175N013
4E	Knob and M6 & Nyloc Nut - 2000mm Track	20	M175N013
5	RLCP Track End Cap (Left)	2	M526
6A	Track 1200mm	2	A256-1200
6B	Track 1400mm	2	A256-1400
6C	Track 1600mm	2	A256-1600
6D	Track 1800mm	2	A256-1800
6E	Track 2000mm	2	A256-2000
7	RLCP Track End Cap (Right)	2	M525
8	M6 x 35mm Security Screw	4	B092
9	M6 Spring Washer	4	W004
10	M6 x 12.5mm Flat Washer	4	W003
11	RLCP Leg	4	M123
12	RLCP Top Pad	4	M173
13	RLCP Base Pad	4	M172
14	M6 x 16mm Dowel Nut	4	N027
15	M6 Dowel Nut Housing	4	A341
16	M10 x 20mm Hex Bolt	4	B003
17	M10 Internal Shake Proof Washer	4	W021
18	M10 x 38mm Flat Washer	4	W022
19A	6mm x 35mm O-ring - 1200mm Track	8	C347
19B	6mm x 35mm O-ring - 1400mm Track	10	C347
19C	6mm x 35mm O-ring - 1600mm Track	12	C347
19D	6mm x 35mm O-ring - 1800mm Track	14	C347
19E	6mm x 35mm O-ring - 2000mm Track	16	C347
20A	M6 x 35mm T-Bolt - 1200mm Track	12	B129
20B	M6 x 35mm T-Bolt - 1400mm Track	14	B129
20C	M6 x 35mm T-Bolt - 1600mm Track	16	B129
20D	M6 x 35mm T-Bolt - 1800mm Track	18	B129
20E	M6 x 35mm T-Bolt - 2000mm Track	20	B129
21	M10 Channel Nut	4	N024
22	5mm Security Allen Key	1	H021
23*	Butyl Patch 20mm x 20mm	12-20	CA1397
24	Fitting Instruction	1	RR-137

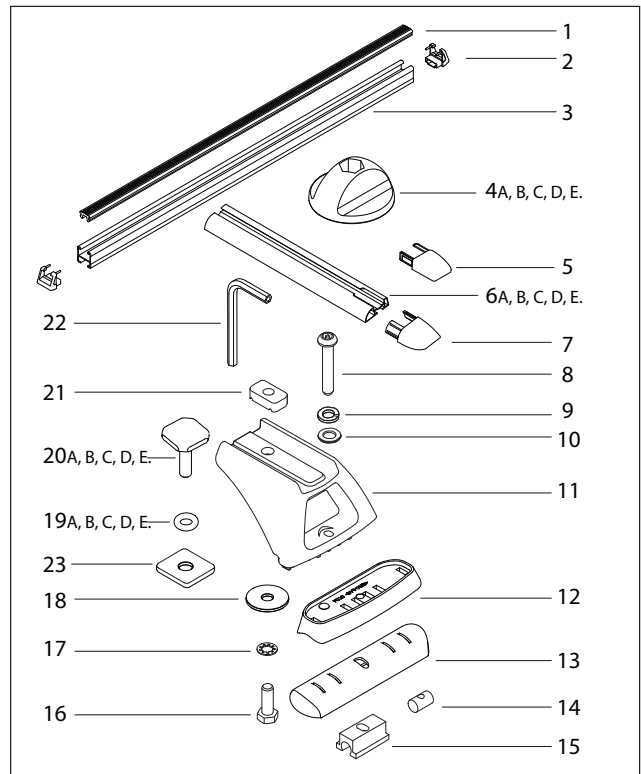

Care Instruction:

Thoroughly clean canopy/tonneau cover prior to fitting the Rhino tracks and heavy duty roof racks.

Tools Required:

Allen key, provided in kit.
 Vacuum cleaner.
 Tape measure.
 Marking pen.
 Power or Battery drill.
 6.5mm drill bit.
 16mm spanner or socket wrench.

*Note:

Butyl Patch (CA1397) quantity will match the T-Bolts provided in kit.

Part Quantities will vary depending on kit purchased.

- 1** When positioning the tracks ensure tracks are parallel and all corners of track are centrally located. Ensure ends with cutouts are placed at the rear of the vehicle with square side facing inward and curved side facing outward.

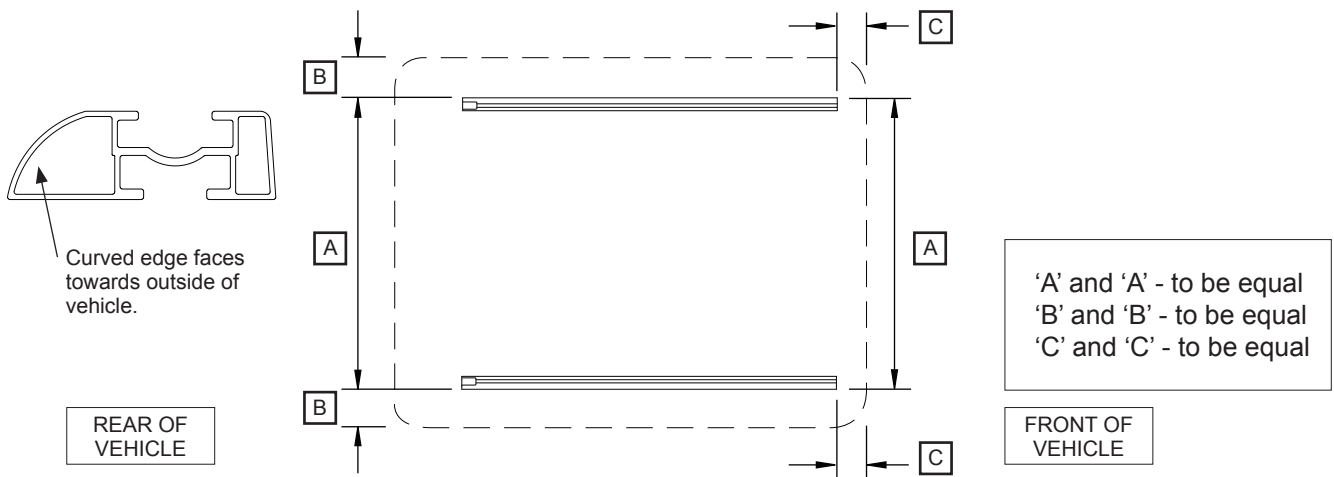

- 2** Position the tracks as close as possible to the outside edge of the canopy, this will ensure maximum strength. **Before marking track holes, check on underside of canopy to ensure knobs have sufficient clearance to be located.**



- 3** Mark end of tracks and mark the centre of the C-channel on both ends of each track. Move the track out slightly and use it as a straight edge to join the two points.

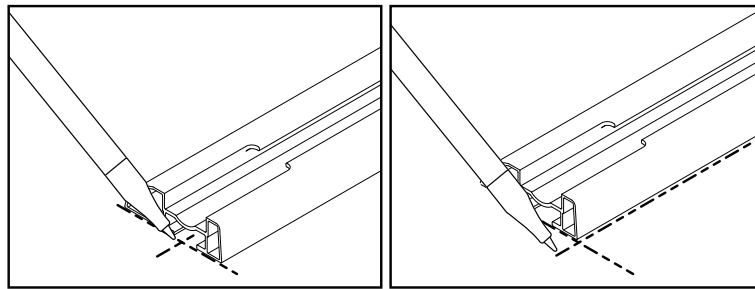

- 4** Mark and drill holes, as shown. Mark end holes 15mm in from end of tracks (the center of the T-bolt is placed 15mm from the end of the tracks). Spacing for T-bolt holes to be no greater than 280mm. Refer diagram. Vacuum fibreglass particles off canopy surface.

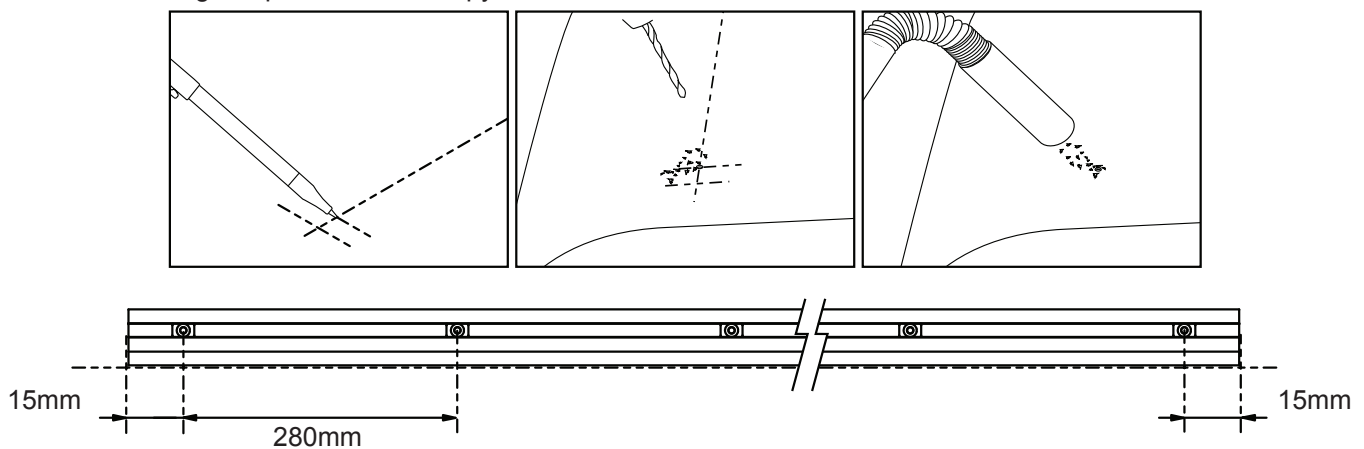

5 Install the rubber o-rings onto each T-bolt (T-Bolts used in end caps do not require o-rings). Locate T-bolts in C-groove on underside of track.

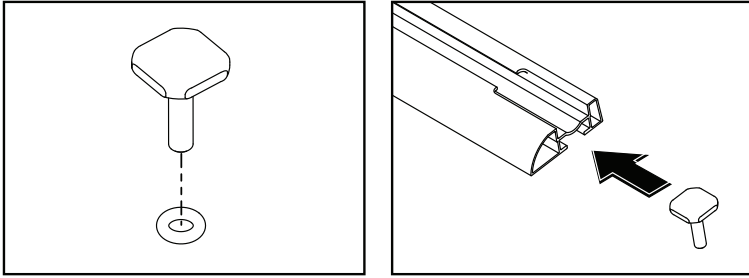

6 1: Remove the backing tape from the Butyl Patches. 2: Place over holes drilled. Once in place remove the rest of the protective tape from the top of the patches.

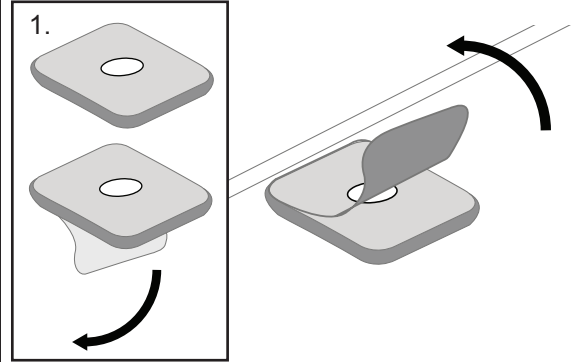

7 Install track end caps. Remove paper gasket from foam tape on underside of track. Place tracks onto canopy / hard tonneau. Ensure the cut outs are placed toward the rear of the vehicle. Double check that all T-bolts have o-rings fitted.

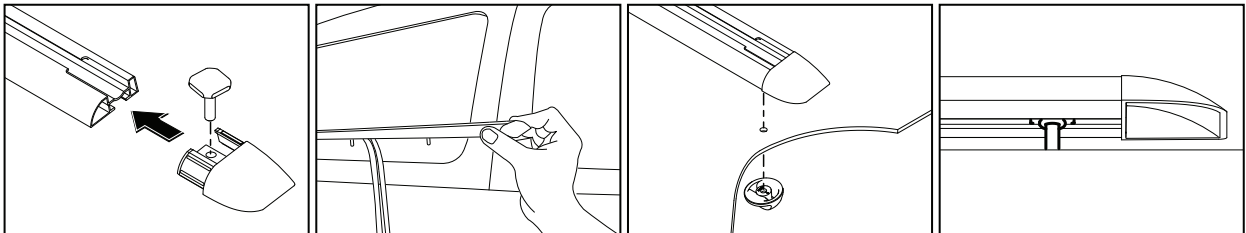

8 Gently Finger tighten T-bolts only at this stage. Once all have been started then tighten in the pattern as shown below. Ensure all knobs are in line as shown. **DO NOT OVER TIGHTEN.**

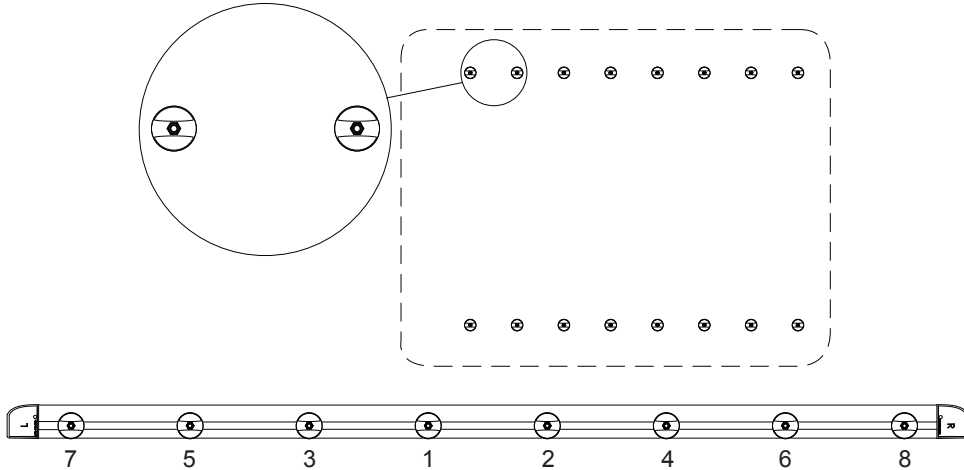

9 Place dowel nut housing in the large cut out in track. Slide along to desired position.

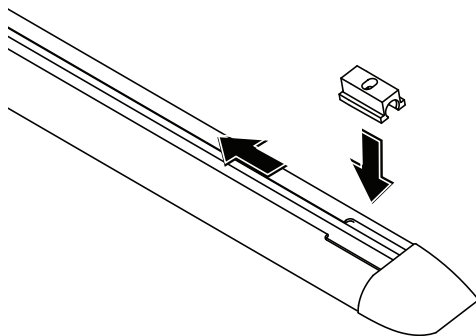

10 Position base pad and top pad over dowel nut housing. **Note: The four location tangs on the top pad face toward outside of vehicle.**

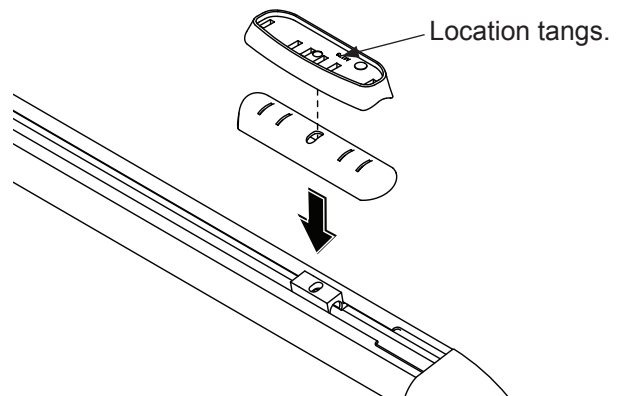

- 11** Insert the heavy duty leg assembly into the underside channel of the cross bar.

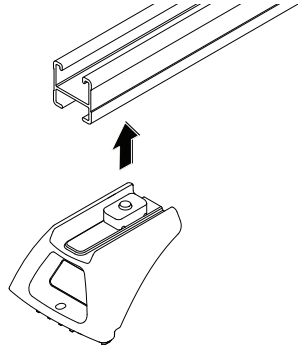

- 12** Tighten the leg attachment bolt so that the channel nut turns to locate across the cross bar. Finger tighten the bolt, as the legs will require adjustment later.

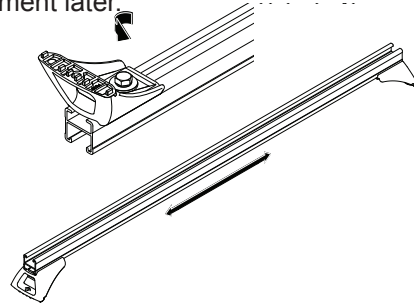

- 13** Check that the channel nut is fully located across the bar.

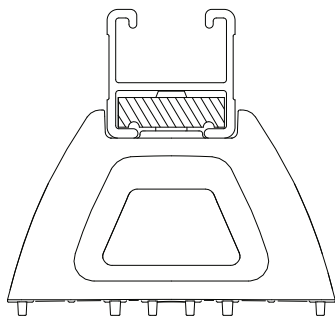

- 14** Insert the support legs into the mounting pads.

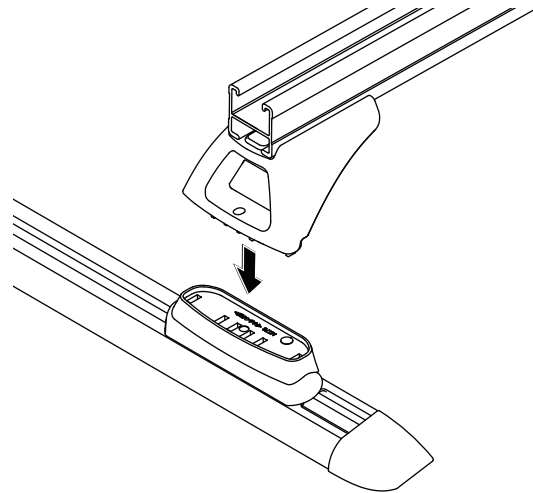

- 15** Place the M6 spring washer and M6 flat washer onto the M6 x 35mm security screw. Insert the M6 screw assembly through the support leg and screw into the dowel nut inside the dowel nut housing.

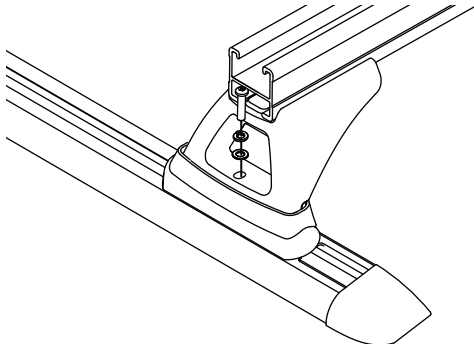

- 16** Using the security allen key provided tighten support leg attachment screws to secure the cross bars. Recommended tightening torque 3-4 Nm. **DO NOT OVER TIGHTEN.**

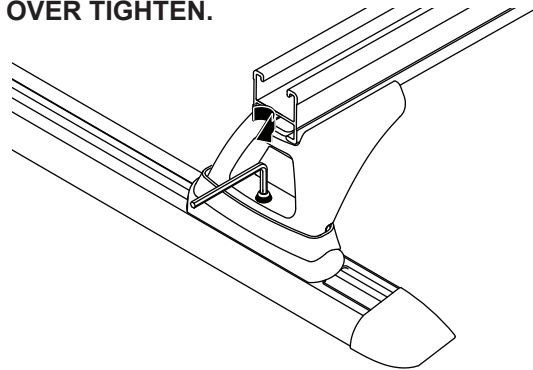

- 17** Check the cross bar over hang (A) (B) is equal on both sides, re-adjust if required.

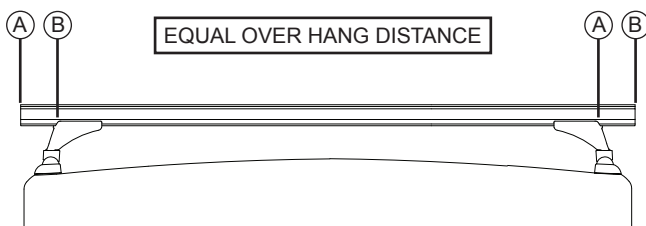

- 18** Tighten the cross bar attachment bolts. Recommended tightening torque 17-19 Nm. **DO NOT OVER TIGHTEN.** Check that the channel nut is located across the cross bar.

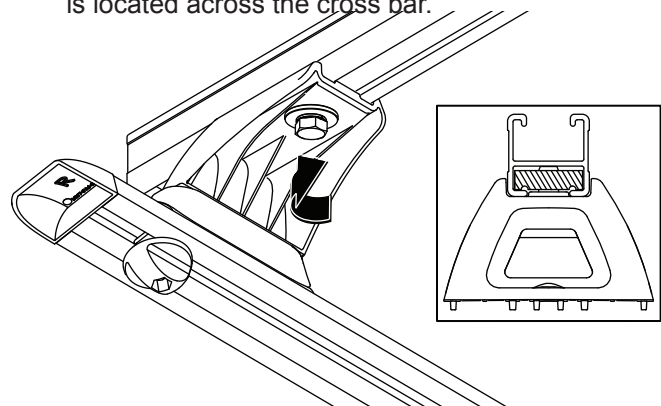

19

Insert the cross bar rubber buffer strip into the top of the cross bar. Insert the end caps into the ends of the cross bar, a rubber mallet may be required to fit the end caps.

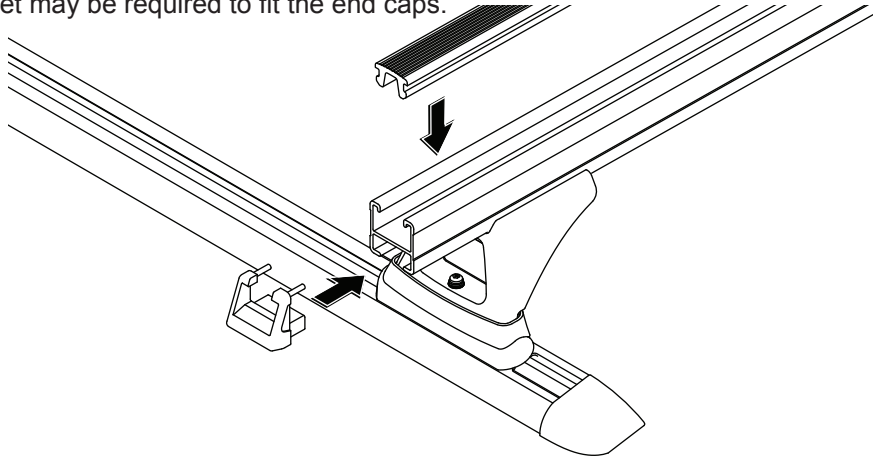

Important Information

Recommendations:

It is essential that all bolt connections be checked after driving a short distance when you first install your cross bars. Bolt connections should be checked again at regular intervals (probably once a week is enough, depending on road conditions, usage, loads and distances travelled). You should also check the cross bars each time they are refitted. Make sure to fasten your load securely. Please ensure that all loads are evenly distributed and centre of gravity is kept as low as possible.

USE ONLY NON-STRETCH FASTENING ROPES OR STRAPS.

Vehicle handling characteristics.

The handling characteristics of the vehicle, changes when you transport a load on the roof. For safety reasons, we recommend you exercise extreme care when transporting wind-resisting loads; special consideration must be taken into account when braking.

PLEASE REMOVE CROSS BARS WHEN PUTTING VEHICLE THROUGH AN AUTOMATIC CAR WASH.

LOAD RATINGS:

Maximum Carrying Capacity: Due to the varying thickness and strengths of canopies Rhino-Rack cannot recommend a weight carrying capacity. Please refer to the canopy manufacturer.

Please refer to vehicle specific manual for load rating. When cross bars are to be used in extreme off road conditions please build a safety factor of 1.5 into the load rating. Although the roof racks are tested and approved to AS1235-2000, Australian road conditions can be much more rigorous. However, increasing the number of cross bars does not increase the vehicles maximum permissible roof loading.

Important note for dealers and fitters.

Rhino-Rack cannot be held responsible for incorrect mounting of units or usage that exceeds production tolerance. If any of these fitting instructions are unclear to you, the fitter, please contact Rhino-Rack. It is your responsibility to ensure the instructions are given to the end user or client.