



# RHINO-RACK

## RLCP Rhino Heavy Duty - Canopy / Hard Tonneau Track Mount

**Important:** Please read these instructions carefully prior to installation. Please refer to your fitting instruction to ensure that the roof racks are installed in the correct locations. Check the contents of kit before commencing fitment and report any discrepancies. Place these instructions in the vehicle's glove box after installation is complete.

### Parts List

**Maximum carrying capacity: Refer to manufactures specifications.**

| Item | Component Name                         | Qty   | Part No   |
|------|--|-------|-----------|
| 1    | Heavy Duty Rubber Buffer Strip         | 2     | R004      |
| 2    | Heavy Duty End Cap                     | 4     | M002      |
| 3    | Heavy Duty Crossbar                    | 2     | A020      |
| 4A   | Knob and M6 & Nyloc Nut - 1200mm Track | 12    | M175N013  |
| 4B   | Knob and M6 & Nyloc Nut - 1400mm Track | 14    | M175N013  |
| 4C   | Knob and M6 & Nyloc Nut - 1600mm Track | 16    | M175N013  |
| 4D   | Knob and M6 & Nyloc Nut - 1800mm Track | 18    | M175N013  |
| 4E   | Knob and M6 & Nyloc Nut - 2000mm Track | 20    | M175N013  |
| 5    | RLCP Track End Cap (Left)              | 2     | M526      |
| 6A   | Track 1200mm                           | 2     | A256-1200 |
| 6B   | Track 1400mm                           | 2     | A256-1400 |
| 6C   | Track 1600mm                           | 2     | A256-1600 |
| 6D   | Track 1800mm                           | 2     | A256-1800 |
| 6E   | Track 2000mm                           | 2     | A256-2000 |
| 7    | RLCP Track End Cap (Right)             | 2     | M525      |
| 8    | M6 x 35mm Security Screw               | 4     | B092      |
| 9    | M6 Spring Washer                       | 4     | W004      |
| 10   | M6 x 12.5mm Flat Washer                | 4     | W003      |
| 11   | RLCP Leg                               | 4     | M123      |
| 12   | RLCP Top Pad                           | 4     | M173      |
| 13   | RLCP Base Pad                          | 4     | M172      |
| 14   | M6 x 16mm Dowel Nut                    | 4     | N027      |
| 15   | M6 Dowel Nut Housing                   | 4     | A341      |
| 16   | M10 x 20mm Hex Bolt                    | 4     | B003      |
| 17   | M10 Internal Shake Proof Washer        | 4     | W021      |
| 18   | M10 x 38mm Flat Washer                 | 4     | W022      |
| 19A  | 6mm x 35mm O-ring - 1200mm Track       | 8     | C347      |
| 19B  | 6mm x 35mm O-ring - 1400mm Track       | 10    | C347      |
| 19C  | 6mm x 35mm O-ring - 1600mm Track       | 12    | C347      |
| 19D  | 6mm x 35mm O-ring - 1800mm Track       | 14    | C347      |
| 19E  | 6mm x 35mm O-ring - 2000mm Track       | 16    | C347      |
| 20A  | M6 x 35mm T-Bolt - 1200mm Track        | 12    | B129      |
| 20B  | M6 x 35mm T-Bolt - 1400mm Track        | 14    | B129      |
| 20C  | M6 x 35mm T-Bolt - 1600mm Track        | 16    | B129      |
| 20D  | M6 x 35mm T-Bolt - 1800mm Track        | 18    | B129      |
| 20E  | M6 x 35mm T-Bolt - 2000mm Track        | 20    | B129      |
| 21   | M10 Channel Nut                        | 4     | N024      |
| 22   | 5mm Security Allen Key                 | 1     | H021      |
| 23*  | Butyl Patch 20mm x 20mm                | 12-20 | CA1266    |
| 24   | Fitting Instruction                    | 1     | RR-137    |

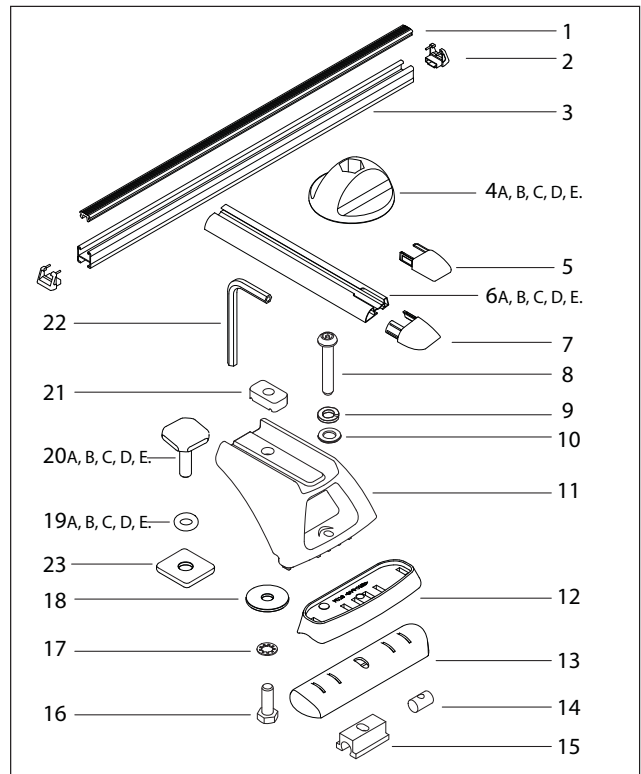

### Care Instruction:

Thoroughly clean canopy/tonneau cover prior to fitting the Rhino tracks and heavy duty roof racks.

### Tools Required:

Allen key, provided in kit.  
 Vacuum cleaner.  
 Tape measure.  
 Marking pen.  
 Power or Battery drill.  
 6.5mm drill bit.  
 16mm spanner or socket wrench.

### \*Note:

Butyl Patch (CA1266) quantity will match the T-Bolts provided in kit.

Part Quantities will vary depending on kit purchased.

- 1** When positioning the tracks ensure tracks are parallel and all corners of track are centrally located. Ensure ends with cutouts are placed at the rear of the vehicle with square side facing inward and curved side facing outward.

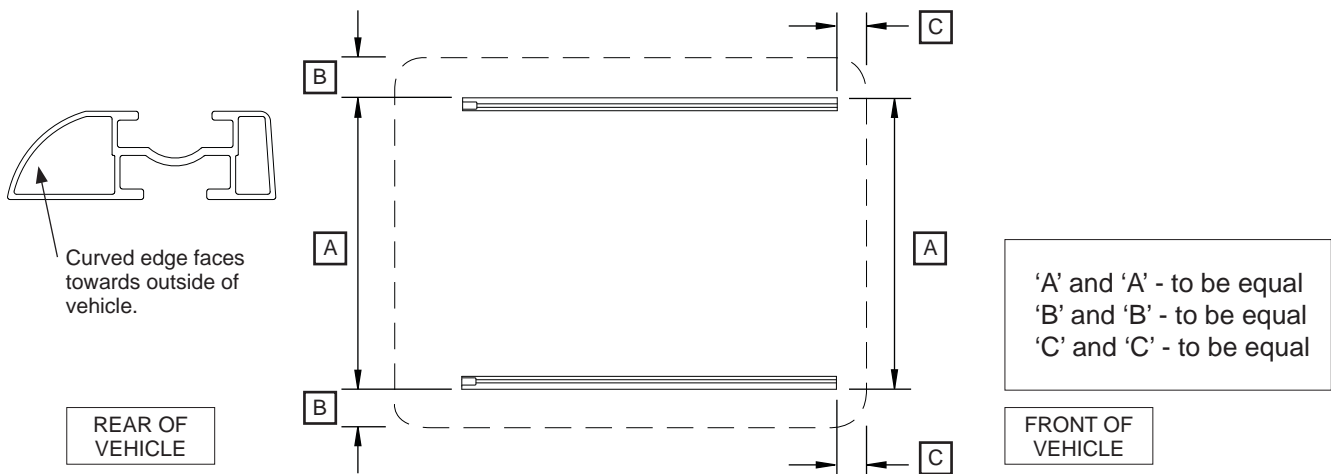

- 2** Position the tracks as close as possible to the outside edge of the canopy, this will ensure maximum strength. **Before marking track holes, check on underside of canopy to ensure knobs have sufficient clearance to be located.**



- 3** Mark end of tracks and mark the centre of the C-channel on both ends of each track. Move the track out slightly and use it as a straight edge to join the two points.

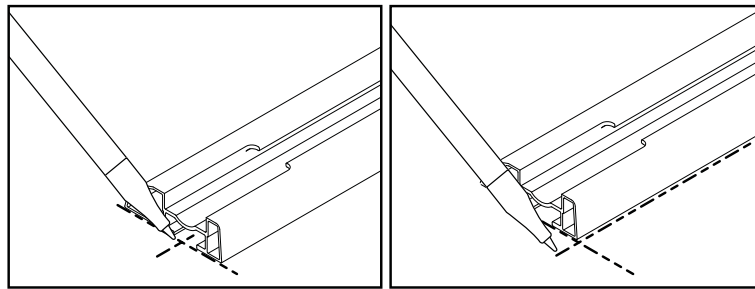

- 4** Mark and drill holes, as shown. Mark end holes 15mm in from end of tracks (the center of the T-bolt is placed 15mm from the end of the tracks). Spacing for T-bolt holes to be no greater than 280mm. Refer diagram. Vacuum fibreglass particles off canopy surface.

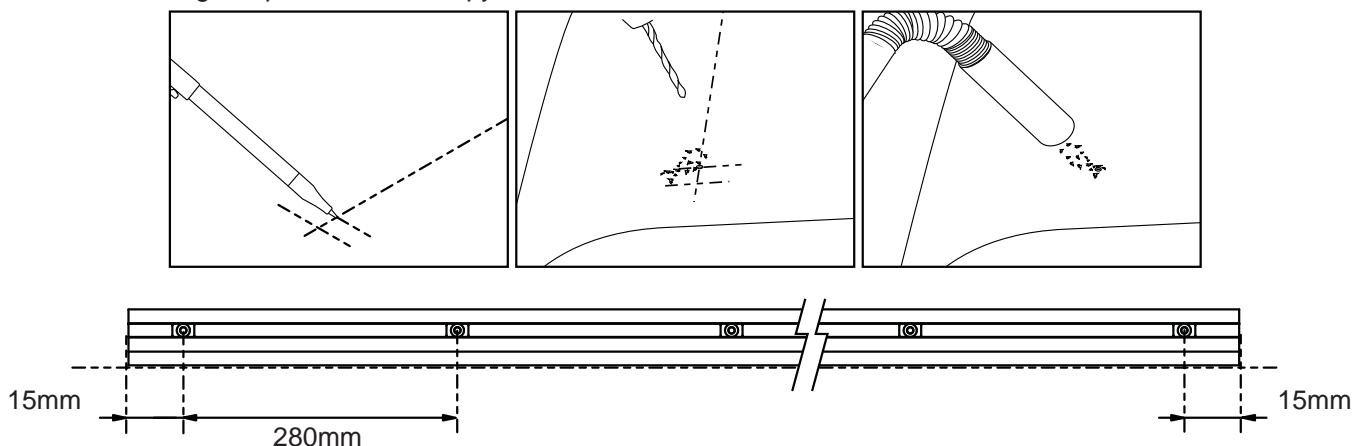

**5** Install the rubber o-rings onto each T-bolt (T-Bolts used in end caps do not require o-rings). Locate T-bolts in C-groove on underside of track.

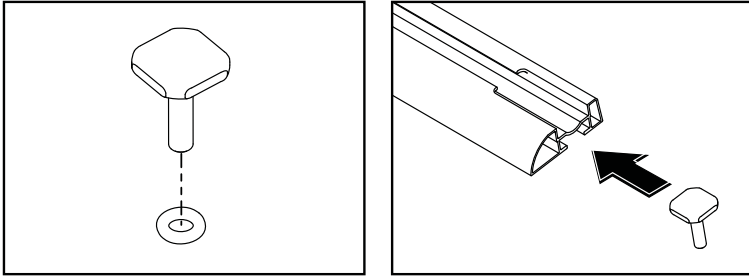

**6** 1: Remove the backing tape from the Butyl Patches. 2: Place over holes drilled. Once in place remove the rest of the protective tape from the top of the patches.

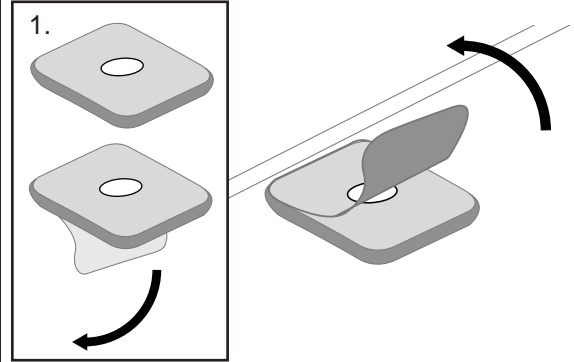

**7** Install track end caps. Remove paper gasket from foam tape on underside of track. Place tracks onto canopy / hard tonneau. Ensure the cut outs are placed toward the rear of the vehicle. Double check that all T-bolts have o-rings fitted.

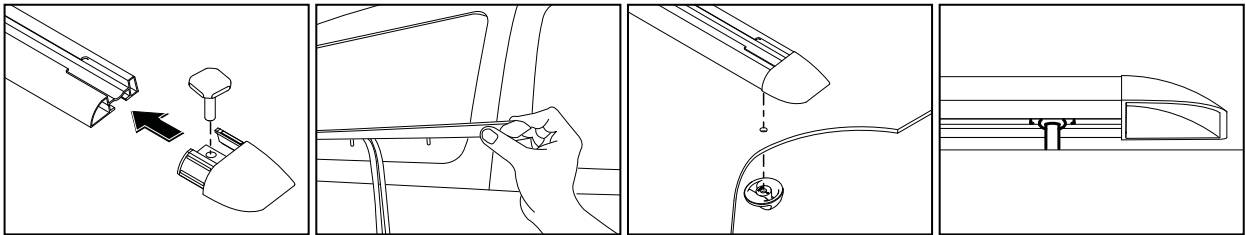

**8** Gently Finger tighten T-bolts only at this stage. Once all have been started then tighten in the pattern as shown below. Ensure all knobs are in line as shown. **DO NOT OVER TIGHTEN.**

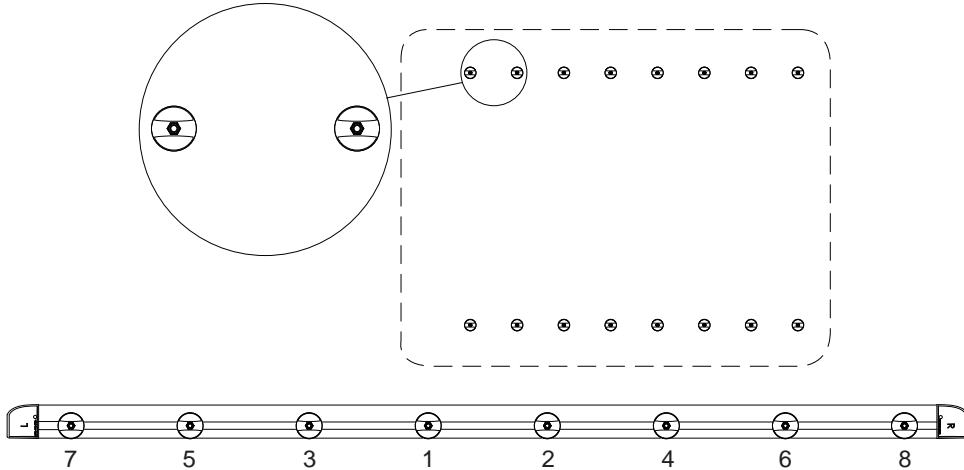

**9** Place dowel nut housing in the large cut out in track. Slide along to desired position.

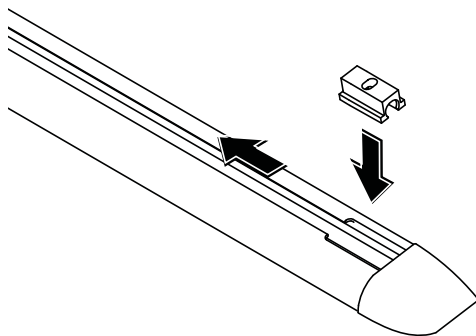

**10** Position base pad and top pad over dowel nut housing. **Note: The four location tangs on the top pad face toward outside of vehicle.**

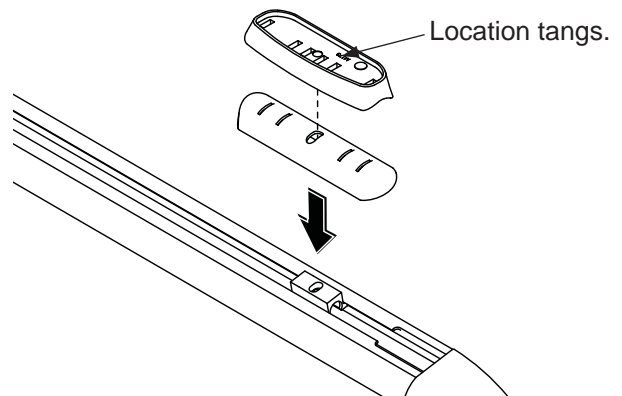

**11** Insert the heavy duty leg assembly into the underside channel of the cross bar.

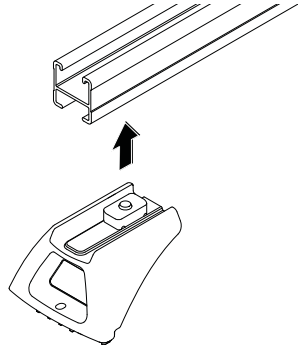

**12** Tighten the leg attachment bolt so that the channel nut turns to locate across the cross bar. Finger tighten the bolt, as the legs will require adjustment later.

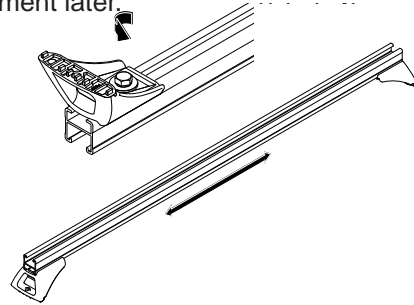

**13** Check that the channel nut is fully located across the bar.

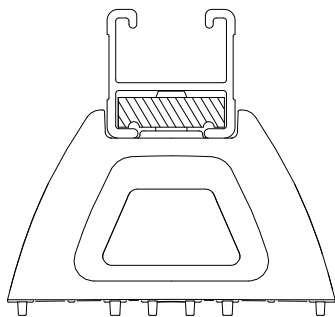

**14** Insert the support legs into the mounting pads.

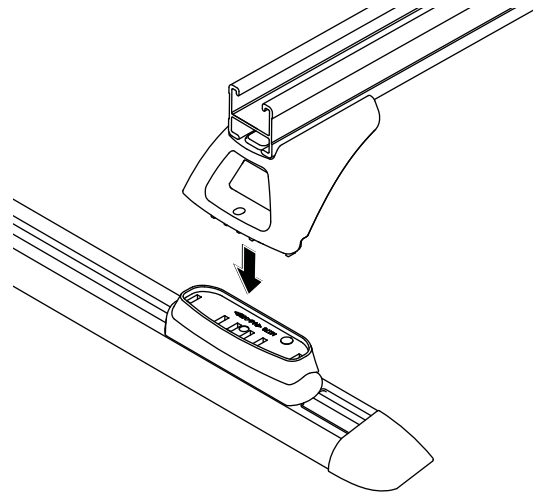

**15** Place the M6 spring washer and M6 flat washer onto the M6 x 35mm security screw. Insert the M6 screw assembly through the support leg and screw into the dowel nut inside the dowel nut housing.

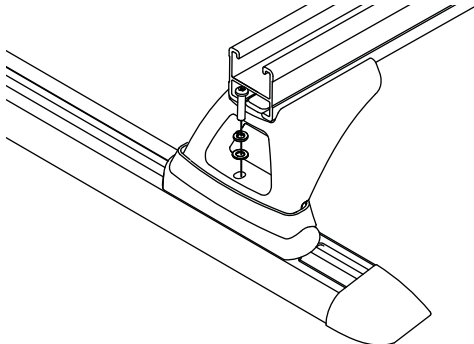

**16** Using the security allen key provided tighten support leg attachment screws to secure the cross bars. Recommended tightening torque 3-4 Nm. **DO NOT OVER TIGHTEN.**

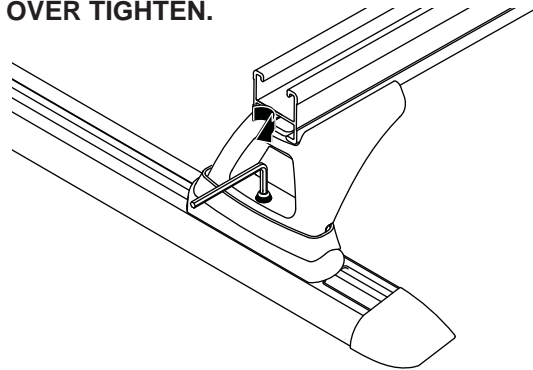

**17** Check the cross bar over hang (A) (B) is equal on both sides, re-adjust if required.

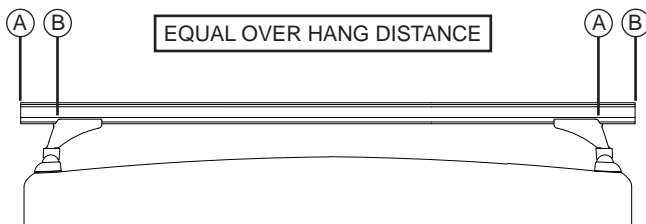

**18** Tighten the cross bar attachment bolts. Recommended tightening torque 17-19 Nm. **DO NOT OVER TIGHTEN.** Check that the channel nut is located across the cross bar.

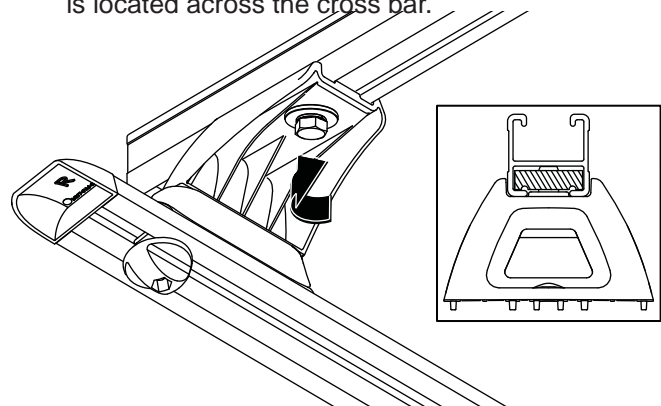

**19**

Insert the cross bar rubber buffer strip into the top of the cross bar. Insert the end caps into the ends of the cross bar, a rubber mallet may be required to fit the end caps.

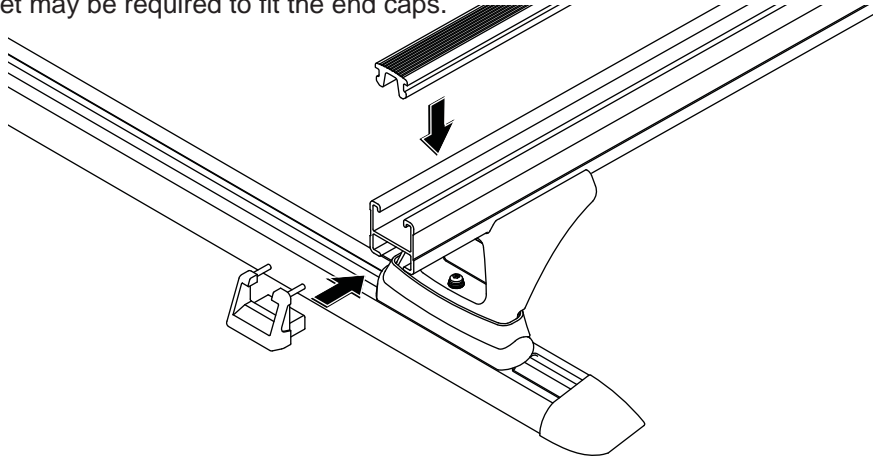

### Important Information

#### **Recommendations:**

It is essential that all bolt connections be checked after driving a short distance when you first install your cross bars. Bolt connections should be checked again at regular intervals (probably once a week is enough, depending on road conditions, usage, loads and distances travelled). You should also check the cross bars each time they are refitted. Make sure to fasten your load securely. Please ensure that all loads are evenly distributed and centre of gravity is kept as low as possible.

#### **USE ONLY NON-STRETCH FASTENING ROPES OR STRAPS.**

#### **Vehicle handling characteristics.**

The handling characteristics of the vehicle, changes when you transport a load on the roof. For safety reasons, we recommend you exercise extreme care when transporting wind-resisting loads; special consideration must be taken into account when braking.

#### **PLEASE REMOVE CROSS BARS WHEN PUTTING VEHICLE THROUGH AN AUTOMATIC CAR WASH.**

#### **LOAD RATINGS:**

**Maximum Carrying Capacity:** Due to the varying thickness and strengths of canopies Rhino-Rack cannot recommend a weight carrying capacity. Please refer to the canopy manufacturer.

Please refer to vehicle specific manual for load rating. When cross bars are to be used in extreme off road conditions please build a safety factor of 1.5 into the load rating. Although the roof racks are tested and approved to AS1235-2000, Australian road conditions can be much more rigorous. However, increasing the number of cross bars does not increase the vehicles maximum permissible roof loading.

#### **Important note for dealers and fitters.**

Rhino-Rack cannot be held responsible for incorrect mounting of units or usage that exceeds production tolerance. If any of these fitting instructions are unclear to you, the fitter, please contact Rhino-Rack. It is your responsibility to ensure the instructions are given to the end user or client.