

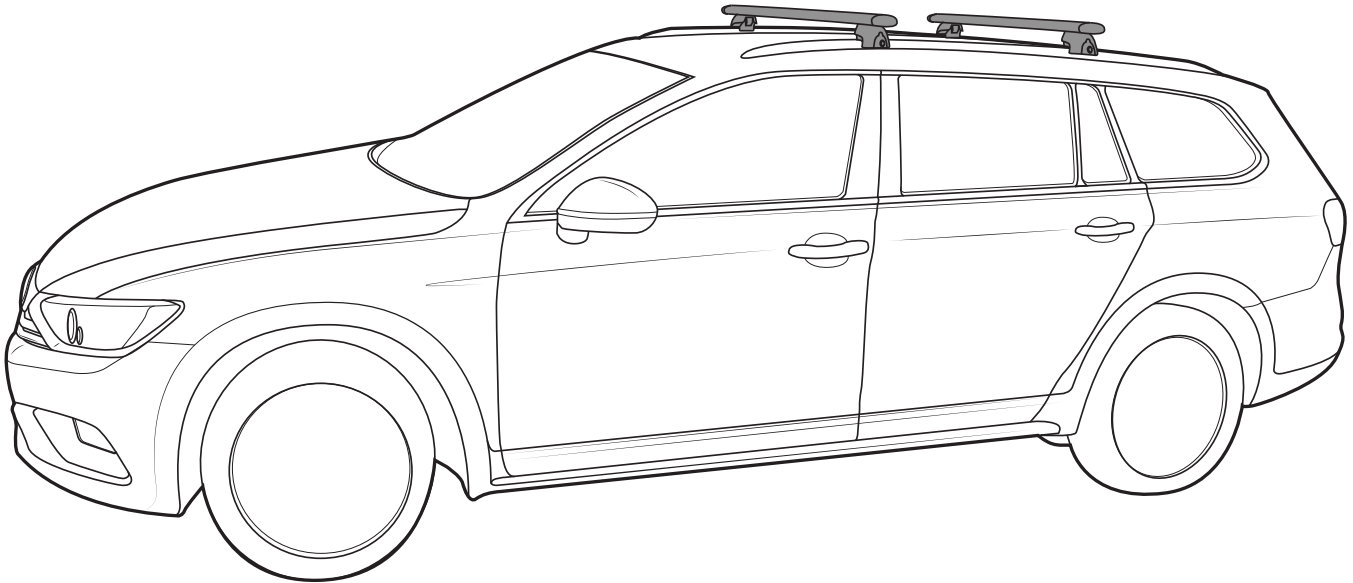

# RHINO-RACK

## SX055 VW Passat

- Important:**
- 1. Please refer to your fitting instruction to ensure that the roof racks are installed in the correct locations.
  - 2. Check the contents of kit before commencing fitment and report any discrepancies.
  - 3. Place these instructions in the vehicle's glove box after installation is complete.
  - 4. These instructions must be followed for warranty to be upheld.



**Maximum carrying capacity: 80kg (176lbs) evenly distributed over crossbars.**

On Road Cargo Allowance	Off Road Cargo Allowance	Roof Allowance	Rack Weight
75kg / 165lb	50kg / 110lbs	80kg / 176lbs	5kg / 11lb

**Advisory:**

It is essential that all bolt connections be checked after 48hrs from when you first install your crossbars. Bolt connections should be checked again at regular intervals (probably once a week is enough, depending on road conditions, usage, loads and distances travelled). You should also check the crossbars each time they are refitted. Make sure to fasten your load securely (see page 2 for advisory diagrams). Please ensure that all loads are evenly distributed and that the centre of gravity is kept as low as possible.

**Caution:**

- The handling characteristics of the vehicle changes when you transport a load on the roof. For safety reasons we recommend you exercise extreme care when transporting wind-resistant loads. Special consideration must be taken into account when cornering and braking. **Please remove crossbars when putting vehicle through an automatic car wash.**
- In heavy winds and high vehicle speeds, increased wind noise may be experienced within the cabin. Roof racks are designed to be quickly and easily removed should the noise level become annoying.
- When fitting to vehicle with moonroof, the roof bars have approximately 10mm clearance. After loading up your roof bars always check the moonroof has clearance during operation. If not, remove crossbars.



# VW Passat SX055

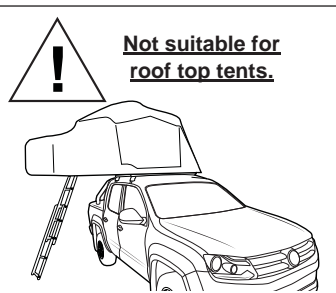
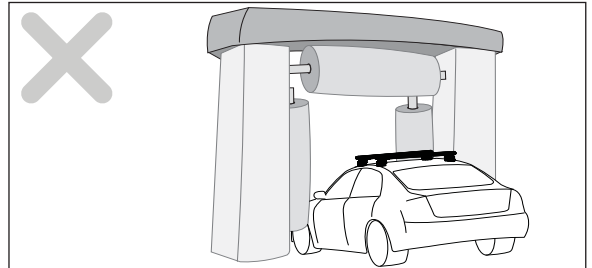
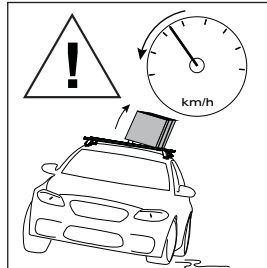
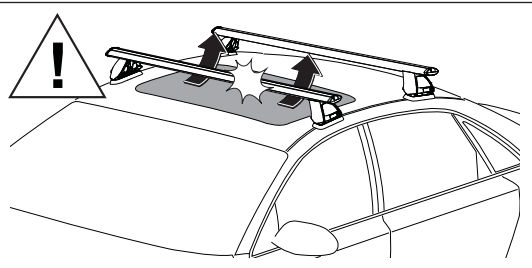
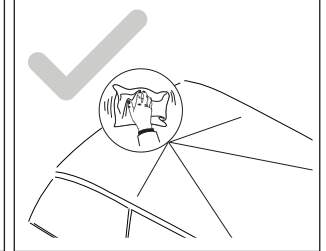
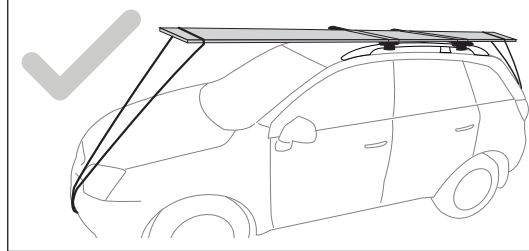
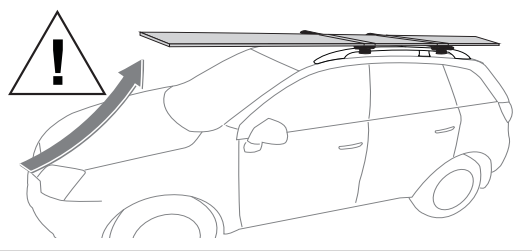

**Not suitable for roof top tents.**

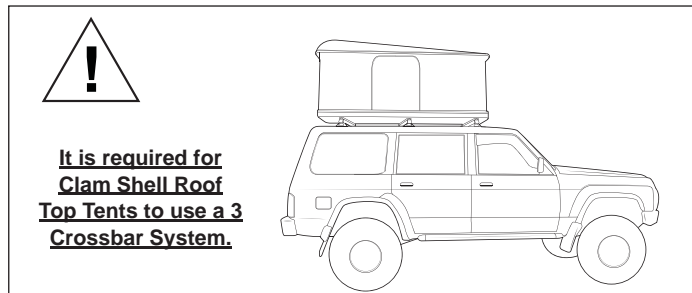

**It is required for Clam Shell Roof Top Tents to use a 3 Crossbar System.**

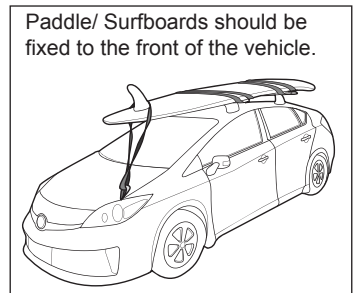

**Paddle/ Surfboards should be fixed to the front of the vehicle.**

**WARNING! Important Load Carrying Instructions**  
 With utility vehicles, the cabin and the canopy move independently. Roof racks and vehicle can be damaged if the item transported is rigidly fixed at points on both the cabin and canopy. Instead, rigidly fix to either the cabin roof racks or the canopy roof racks.

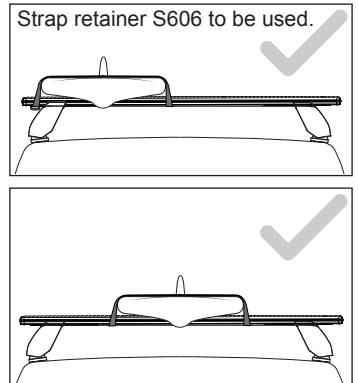
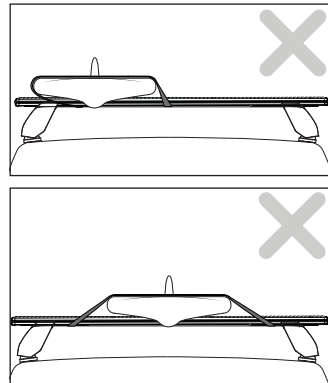

**Strap retainer S606 to be used.**

**Kayaks should use additional straps to secure the load at the front and rear of the vehicle where possible. Always use Kayak Carrier Cradles when transporting Kayaks on the roof.**

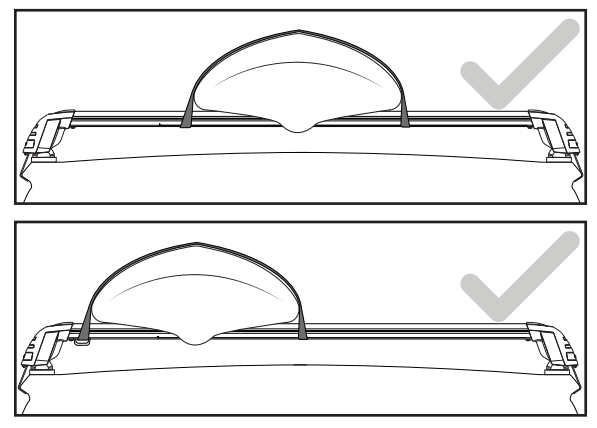
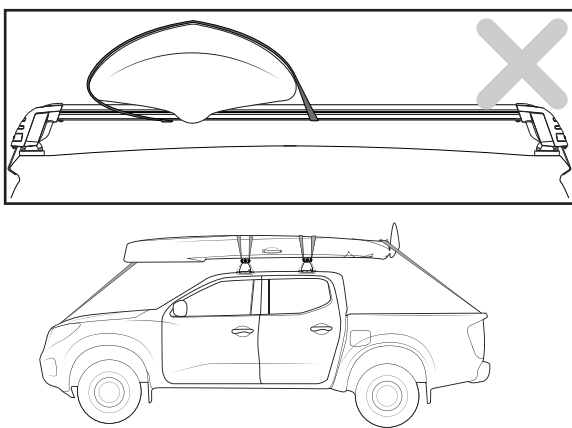

**Optimal Setup:**  
 The Kayak should be housed in Cradles and held in place with tension straps.  
 The front and rear of the Kayak should be fixed to the front and rear of the vehicle. A Nose Tie Down (RBAS1) should be used to secure the front of the Kayak.

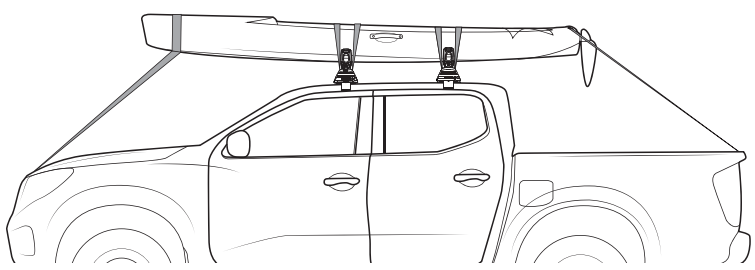



# VW Passat SX055

## Parts Required

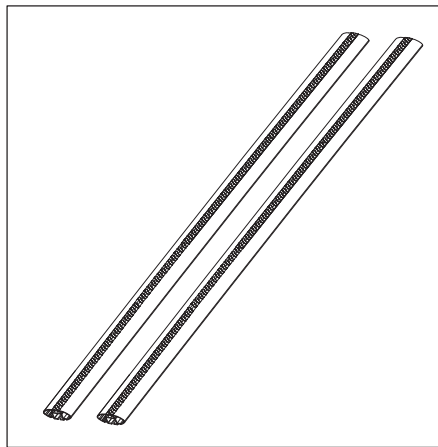

Crossbars  
(VA118 Sold as  
separate)

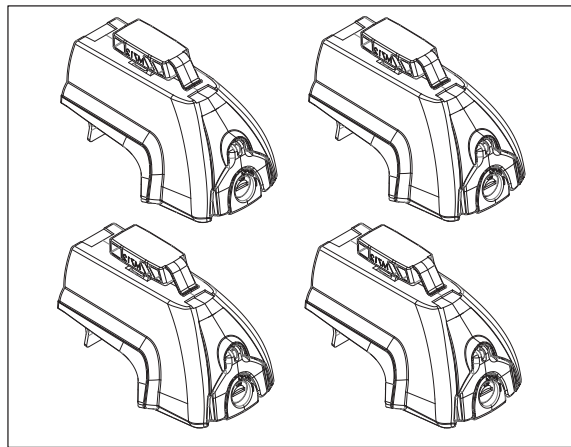

Leg Kit

## Parts List

Item	Component Name	Qty	Part No.
1	Leg Unit	4	CA1600
2	Rubber Insert	4	M798
3	Clamp Assembly	4	CA1557
4	Outer Clamp	4	CA1668
5	Dowel Nut	4	-
6	Adjustment Rod	4	SP222
7	Metal Key	2	CA1344
8	Instructions	1	R747

### Tools Required:

Tape measure.  
Knife.

1.

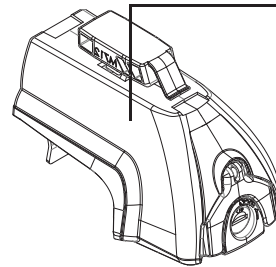

2.

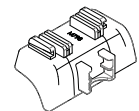

3.



4.

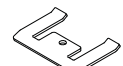

7.



5.

6.

**NOTE:** Items 2 - 7 are  
pre-installed on legs

## Instructions

**1**

Open the Crossbar box and remove the contents. Shake the crossbar up and down to remove measurement strips and rubber buffer strips. Crossbars sold separate.

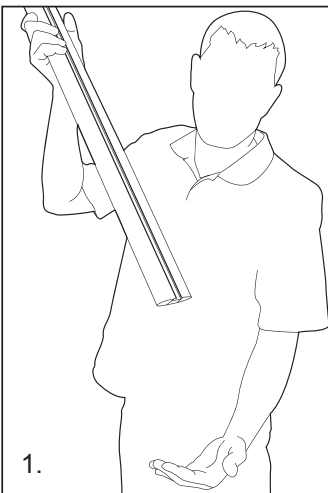

1.

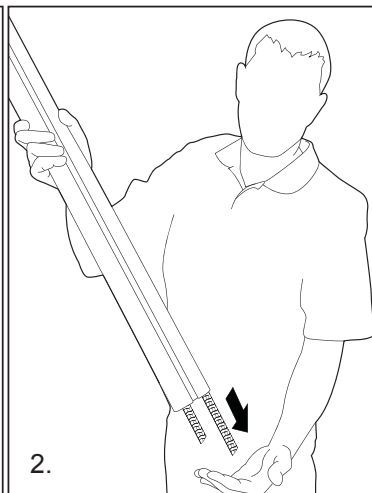

2.

**2**

Install the Rubber Buffer Strips. Cut to size if required.

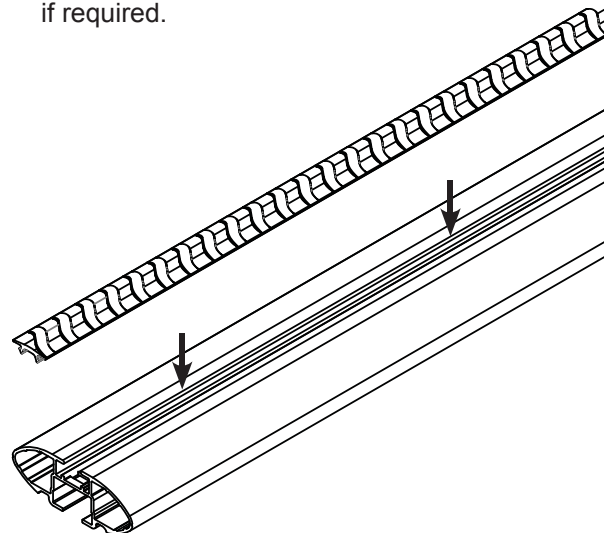



# VW Passat SX055

## 3 Prepare the Legs for installation into the crossbars.

Unlock the unit as shown.

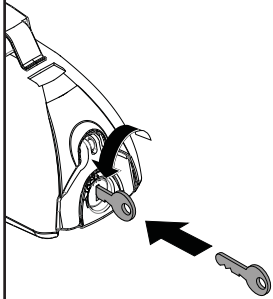

Tighten or loosen the Clamp as required to create a visible gap.

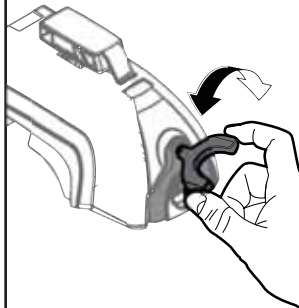

The Clamp is blocking access from the crossbar here

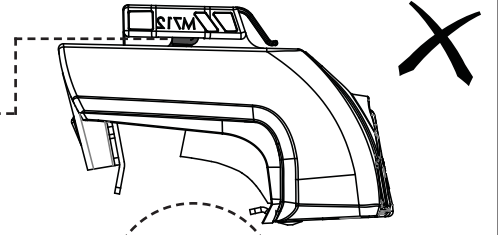

Make sure Metal Clamp Upper is pushed up into housing before inserting into Crossbar.

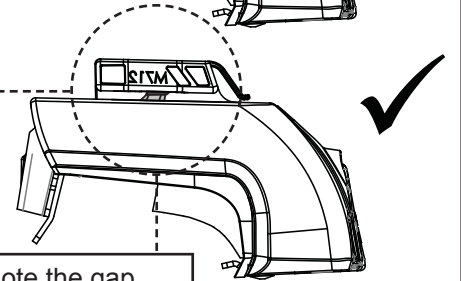

Note the gap. Crossbars will slide through here later.

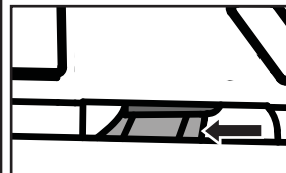

## 4 Slide the Leg Insert into the crossbar as shown. Complete for all four Legs.

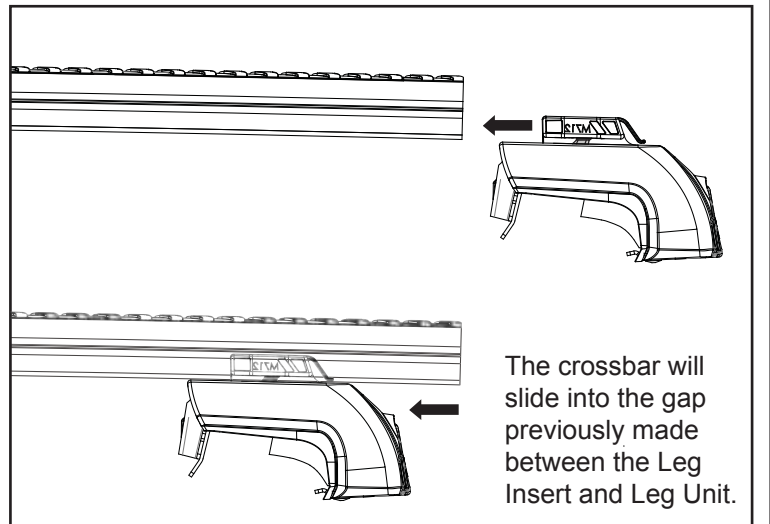
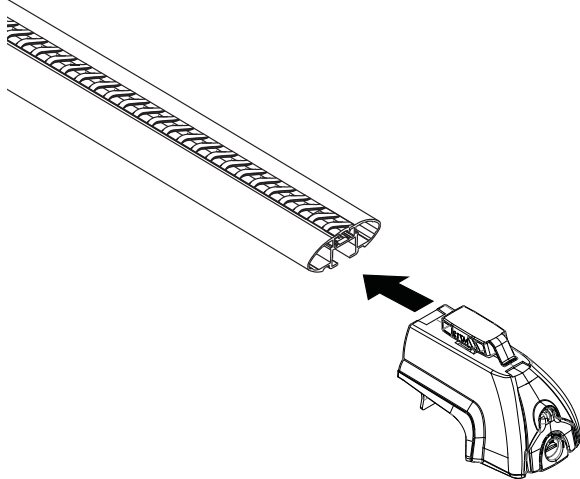

## 5a Place the front and rear crossbars onto the vehicle. (Refer to step 5b for crossbar locations).

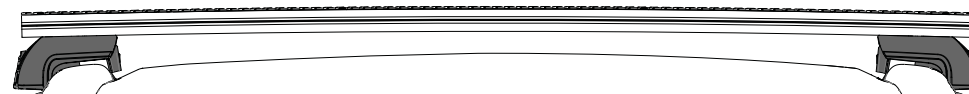

Front View



# VW Passat SX055

**5b** Place the front crossbar in line with the front door jamb (A). From the centre of the front crossbar measure back 600-800mm (depending on size of load to be carried) to the centre of the rear crossbar (B).

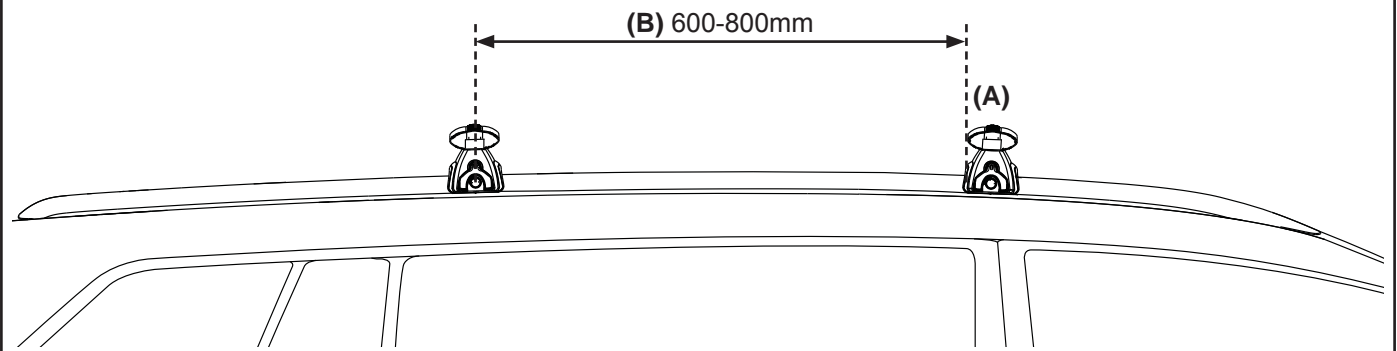

**5c** Be sure the Leg is sitting snug with the factory rail as shown. The Clamp must be in contact with the rail completely along its surface. The Outer Clamp must be gripping on the underside of the rail and the Clamp Assembly should be gripping the rear of the rail as shown.

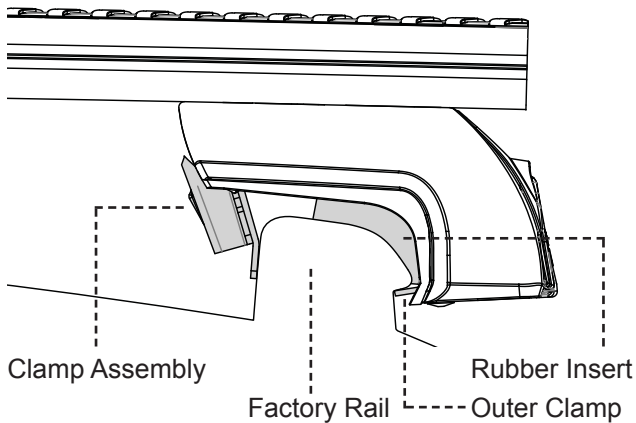

**6** Measure from the end of the crossbar to the rear of the Leg on both sides. Adjust so both measurements are even.

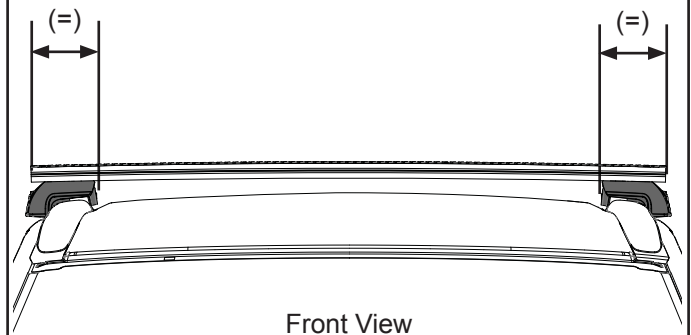

Front View

**7** Tighten the Legs to 5Nm in place. Lock the Leg with Metal Key provided.

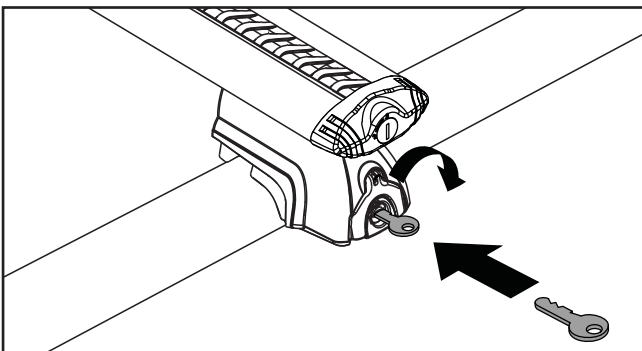
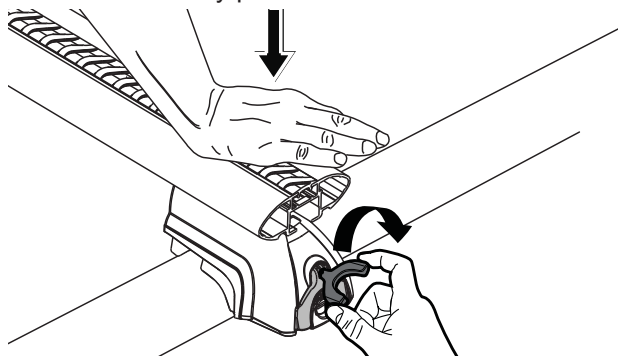

**8** Measure the gap on the underside of the Crossbars. Accurately cut the underbar strips to match.

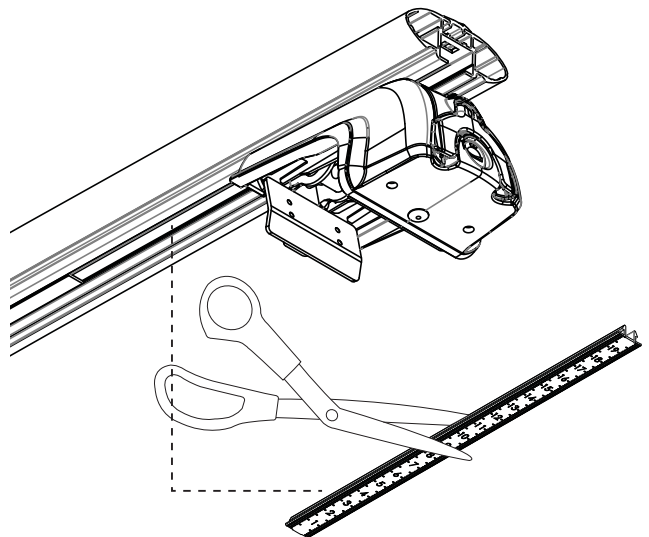



## VW Passat SX055

- 9** With the Underbar Strips cut to the required lengths, install them into the Crossbars. 1: Slide one end into the place behind the Leg. 2: Push the Underbar Strip up and into place along its length. 3: Be sure Strip is secure.

**Note: The Underbar Strips will ensure the Crossbars do not create a 'whistling' noise at speed.**

1:

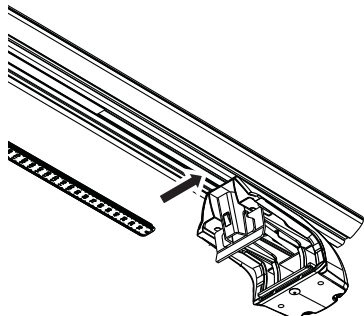

Slide one end of the Underbar strip in behind the Leg as shown.

2:

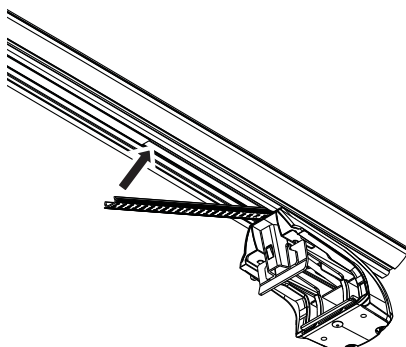

3: Be sure the strip is fully located along its length.

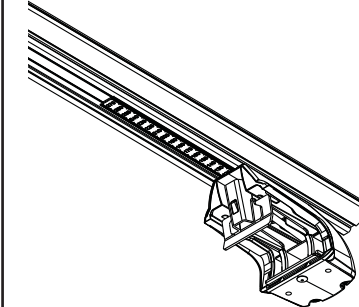

- 10** Now slide in remaining underbar strip into the outer slot and trim off flush using a knife.

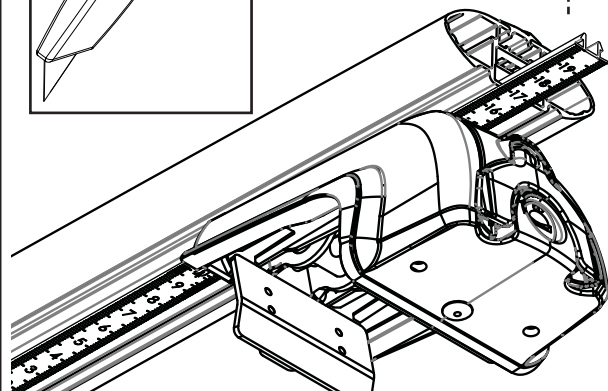
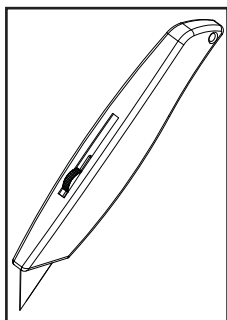

- 11** Insert end caps. Lock and remove key.

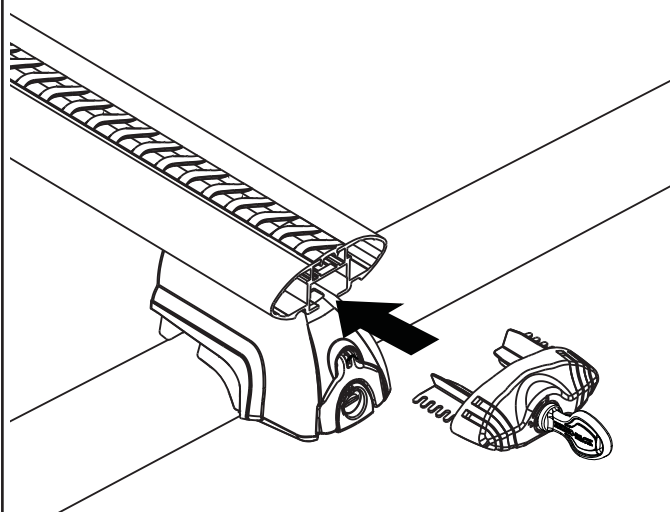

- 12** Be sure all fittings are secure before use.

