



RHINO-RACK®

Universal Backbone Fitting Instructions RUMB1 & RUMB2

Important:

1. Check the Rhino-Rack website to ensure you have the latest issue of these instructions.
2. Please refer to your fitting instruction to ensure that the roof racks are installed in the correct locations.
3. Check the contents of kit before commencing fitment and report any discrepancies.
4. Place these instructions in the vehicle's glove box after installation is complete.
5. These instructions must be followed for warranty to be upheld.

Fit Time: 1 hour

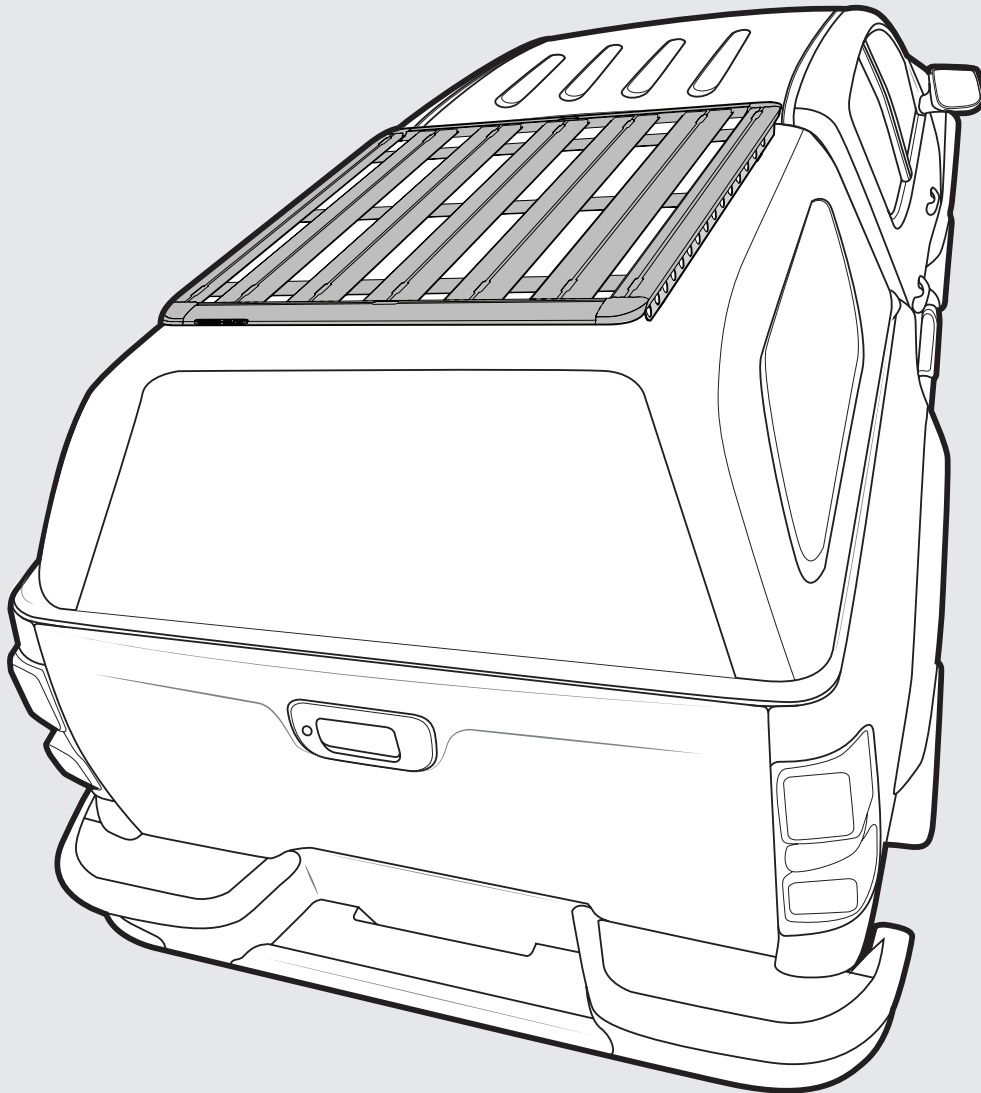

RUMB1 & RUMB2 Backbone Instructions

Carrying Capacity

Check the website, the canopy/topper manufacturer's roof load capacity and the vehicle owners hand book for your vehicle's maximum carrying capacity. Always use the lowest value. Load must be evenly distributed over the system.



Cargo Load Limit

Total permissible weight allowed on top, and attached to roof racks whilst the vehicle is in motion.

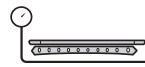

System Weight

Total weight of the roof rack system. (Crossbars, Backbone, Platform)



Max System Load Capacity

Please ensure you use the vehicle manufacturer's maximum roof allowance if it is lower than the figure listed in the fitting chart.



Vehicle Manufacturer's Load Limit

Total permissible weight attached to the roof of the car. This is inclusive of the weight of the roof rack system.

Warning

- Check part number or kit is correct for use with your vehicle.
- Do not attempt to fit the rack system to your vehicle unless you fully understand these fitting instructions. Please direct any questions regarding fitting to the dealer from where the roof racks were purchased.
- Although the system is tested to ISO 11154, off-road conditions can be much more rigorous. Extreme care must be taken on any driven path that does not contain a surface protection layer (tar/bitumen).
- Roof racks must be removed when vehicle is put through an automatic car wash.
- With utility vehicles, the cabin and the canopy move independently. Roof racks and vehicle can be damaged if the item transported is rigidly fixed at points on both the cabin and canopy. Instead, rigidly fix to either the cabin roof racks or the canopy roof racks.
- Always ensure you fasten your load securely.
- Use only non-stretch fastening ropes or straps to attach cargo to your load.

In service maintenance checks

- All bolt connections should be checked after driving a short distance when you first install your roof racks.
- All bolted connections should be checked again at regular intervals (weekly is recommended, depending on road conditions, usage, loads and distances travelled).
- All bolted connections should be checked each time they are re-fitted.
- Off-road conditions are more rigorous. Check all bolted connections and your load more regularly.
- Ensure that your vehicle manufacturer's GVM, and gross axle weights are not exceeded (refer to vehicle owner's manual).

Torque Settings

Unless stated otherwise in these instructions, all fasteners should be set to the following torque settings:







- M6: 4-5Nm (3-4lbs/ft),
- M8: 8-10Nm (6-7.5lbs/ft)
- M10: 16-18Nm (12-13lbs/ft).

Note for Dealers and Fitters

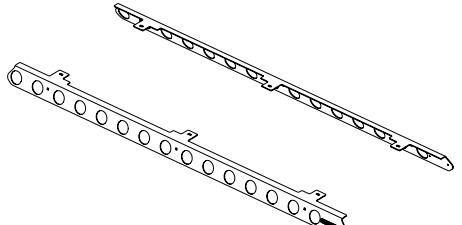
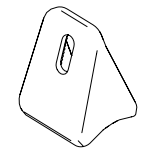
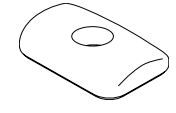
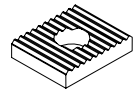
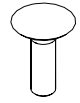
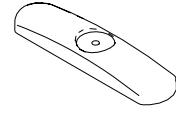
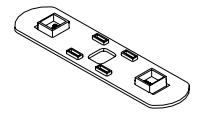
It is your responsibility to ensure these fitting instructions are given to the end user or client. These instructions remain the property of Rhino-Rack Australia Pty. Ltd. and may not be used or changed for any other purpose than intended.

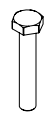
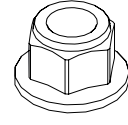
RUMB1 & RUMB2 Backbone Instructions

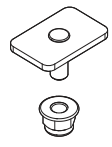
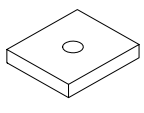
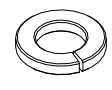
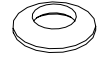
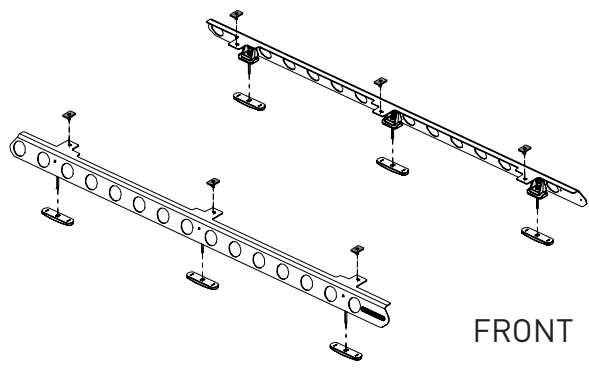
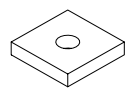
RUMB1 Parts List

<p>Long Universal Backbone (Pair)</p>  <p>A x1</p>	<p>Cast Foot</p>  <p>B x6</p>	<p>Pad Sub Assembly</p>  <p>C x6</p>	
<p>Retention Washer</p>  <p>F x6</p>	<p>M6 X 25 Carriage Screw</p>  <p>G x6</p>	<p>Internal Pad</p>  <p>D x6</p>	<p>Internal Pad Rubber Skirt</p>  <p>E x6</p>
<p>M6 x 60 Hex Head Bolt</p>  <p>J x6</p>	<p>M6 x 30 Hex Head Bolt</p>  <p>K x6</p>	<p>M6 x 1.00 Flanged Nyloc Nut</p>  <p>H x6</p>	<p>M6 x 80 Hex Head Bolt</p>  <p>I x6</p>
<p>Pioneer M8 T-Bolt & Nut</p>  <p>N x6</p>	<p>M6 Plate Nut (24x21x4) For Rhino Rack Tracks</p>  <p>O x6</p>	<p>M6 Spring Washer</p>  <p>L x6</p>	<p>M6 Male Half Spherical Washer</p>  <p>M x6</p>
<p>Use above quantities for installation steps</p>  <p>FRONT</p>	<p>M6 Plate Nut (20x20x3.5) For Thule Tracks</p>  <p>P x6</p>	<p>Instruction</p>  <p>Q x1</p>	

Notes

- Canopy/Topper roof install on Page 5
- Canopy/Topper track install on Page 15
- Use safety gear when drilling through canopy

Tools Required







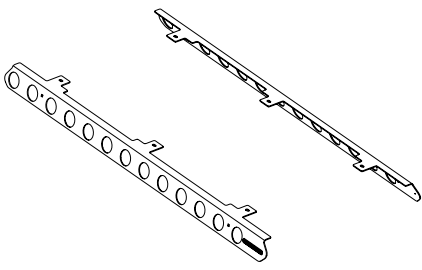
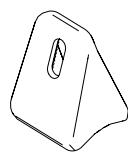
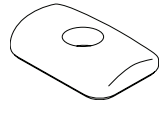
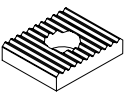
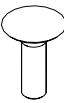
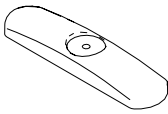
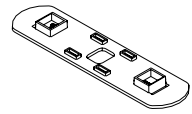
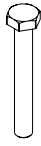

- T1 - Masking Tape
- T2 - Marker
- T3 - Tape Measure
- T4 - 6mm, 1/4" drill bit
- T5 - Drill
- T6 - Spirit Level
- T7 - 10mm wrench
- T8 - 13mm wrench
- T9 - String Line (approx 3m to suit canopy length)
- T10 - Vacuum

Safety Gear

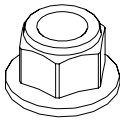

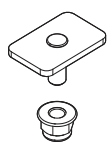
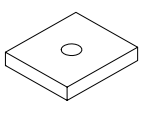
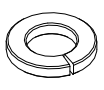
RUMB1 & RUMB2 Backbone Instructions

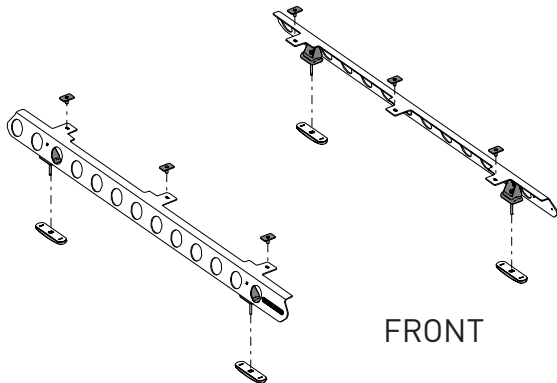
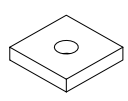
RUMB2 Parts List

<p>Short Universal Backbone (Pair)</p>  <p>A x1</p>	<p>Cast Foot</p>  <p>B x4</p>	<p>Pad Sub Assembly</p>  <p>C x4</p>	
<p>Retention Washer</p>  <p>F x4</p>	<p>M6 X 25 Carriage Screw</p>  <p>G x4</p>	<p>Internal Pad</p>  <p>D x4</p>	<p>Internal Pad Rubber Skirt</p>  <p>E x4</p>
<p>M6 x 60 Hex Head Bolt</p>  <p>J x4</p>	<p>M6 x 30 Hex Head Bolt</p>  <p>K x4</p>	<p>M6 x 1.00 Flanged Nyloc Nut</p>  <p>H x4</p>	<p>M6 x 80 Hex Head Bolt</p>  <p>I x4</p>
<p>Pioneer M8 T-Bolt & Nut</p>  <p>N x6</p>	<p>M6 Plate Nut (24x21x4) For Rhino Rack Tracks</p>  <p>O x4</p>	<p>M6 Spring Washer</p>  <p>L x4</p>	<p>M6 Male Half Spherical Washer</p>  <p>M x4</p>
<p>Use above quantities for short backbone</p>  <p>FRONT</p>	<p>M6 Plate Nut (20x20x3.5) For Thule Tracks</p>  <p>P x4</p>	<p>Instruction</p>  <p>Q x1</p>	

Notes

- Canopy/Topper roof install on Page 5
- Canopy/Topper track install on Page 15
- Use safety gear when drilling through canopy

Tools Required

- T1 - Masking Tape
- T2 - Marker
- T3 - Tape Measure
- T4 - 6mm, 1/4" drill bit
- T5 - Drill
- T6 - Spirit Level
- T7 - 10mm wrench
- T8 - 13mm wrench
- T9 - String Line (approx 3m to suit canopy length)
- T10 - Vacuum

Safety Gear

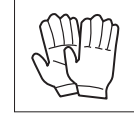

1 CANOPY/TOPPER INSTALL

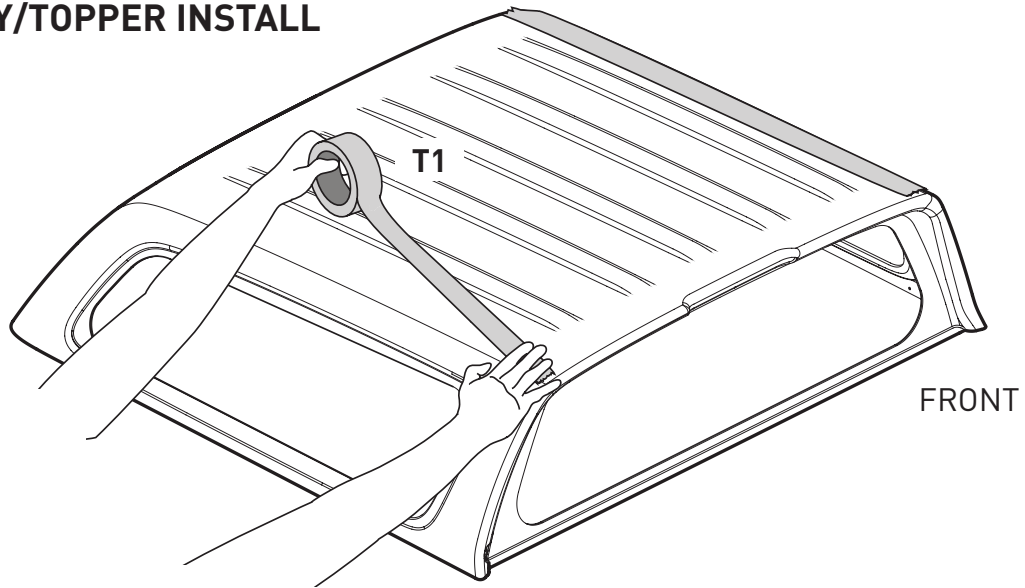

2

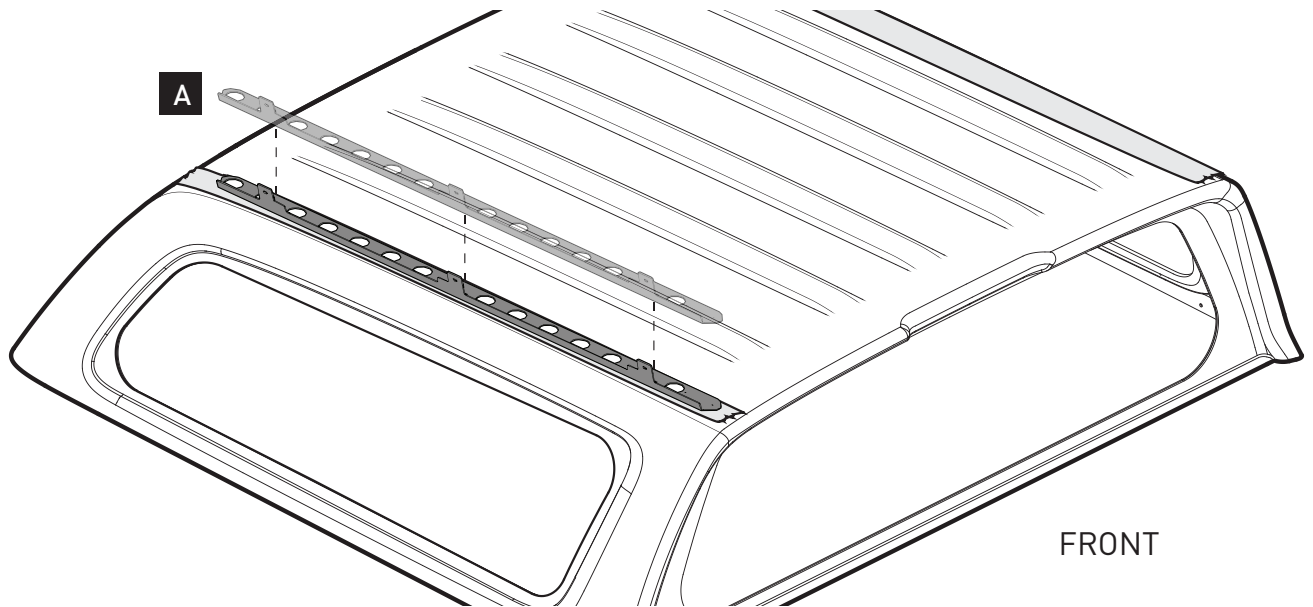

3 Align to a flat area near the edge or next to a reinforcing 'rib' near the edge (strongest area of roof)

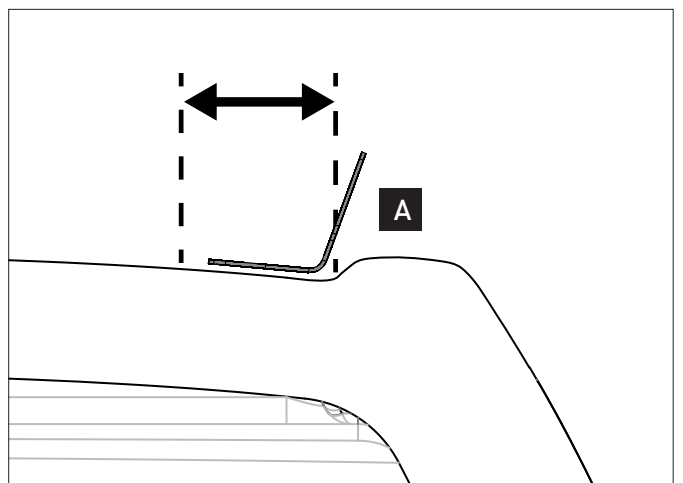
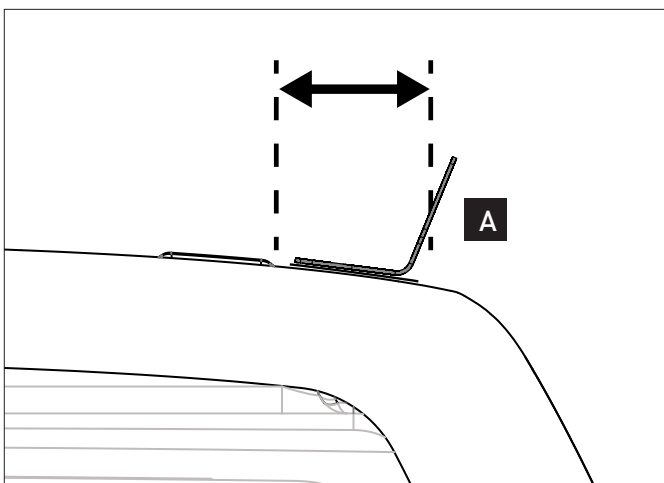

RUMB1 & RUMB2 Backbone Instructions

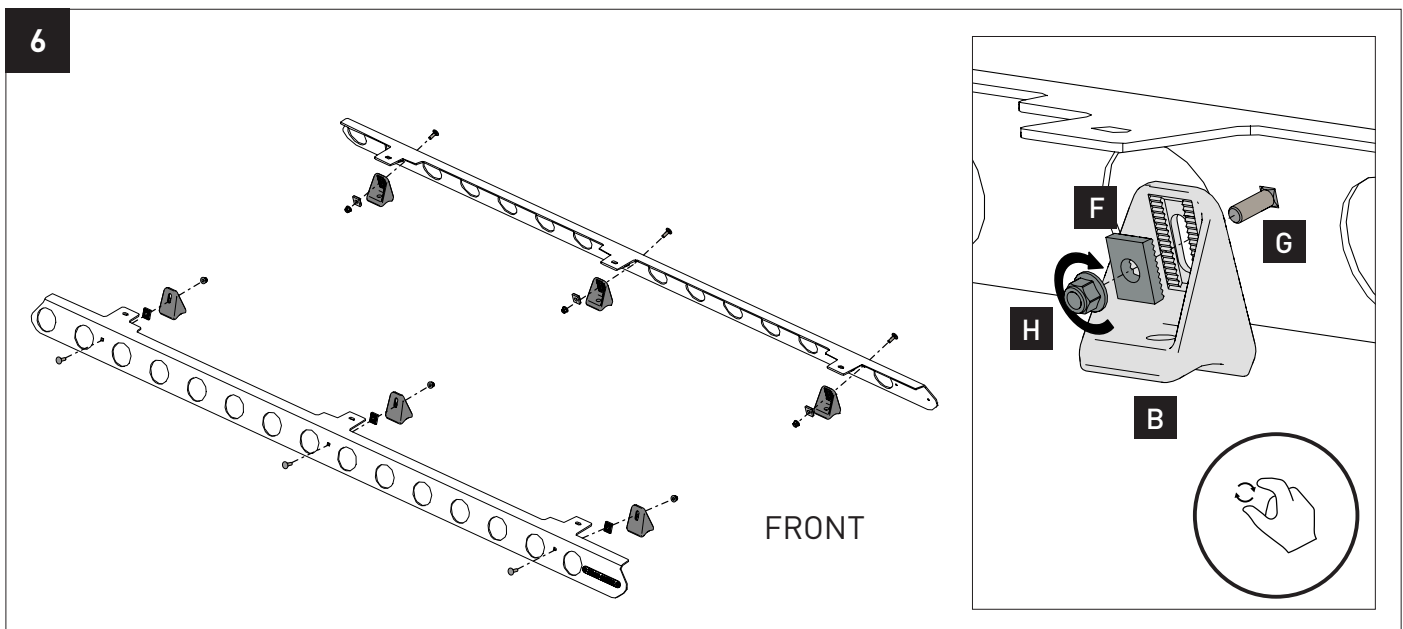
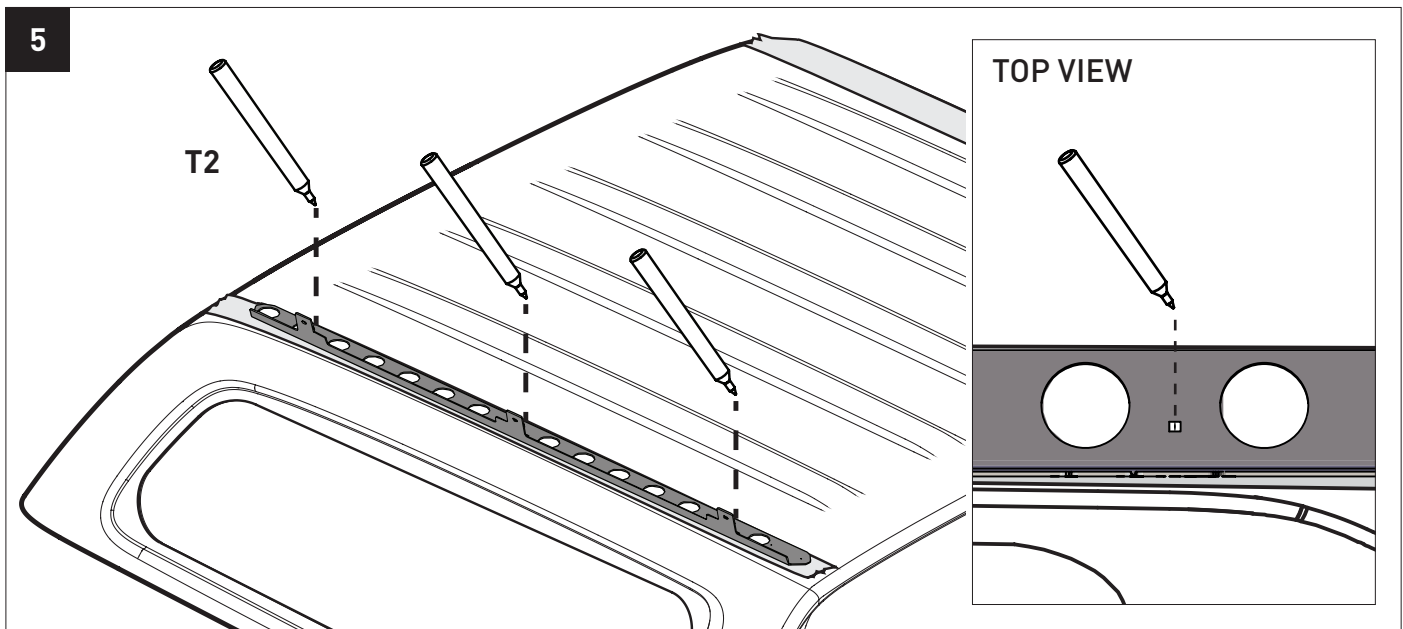
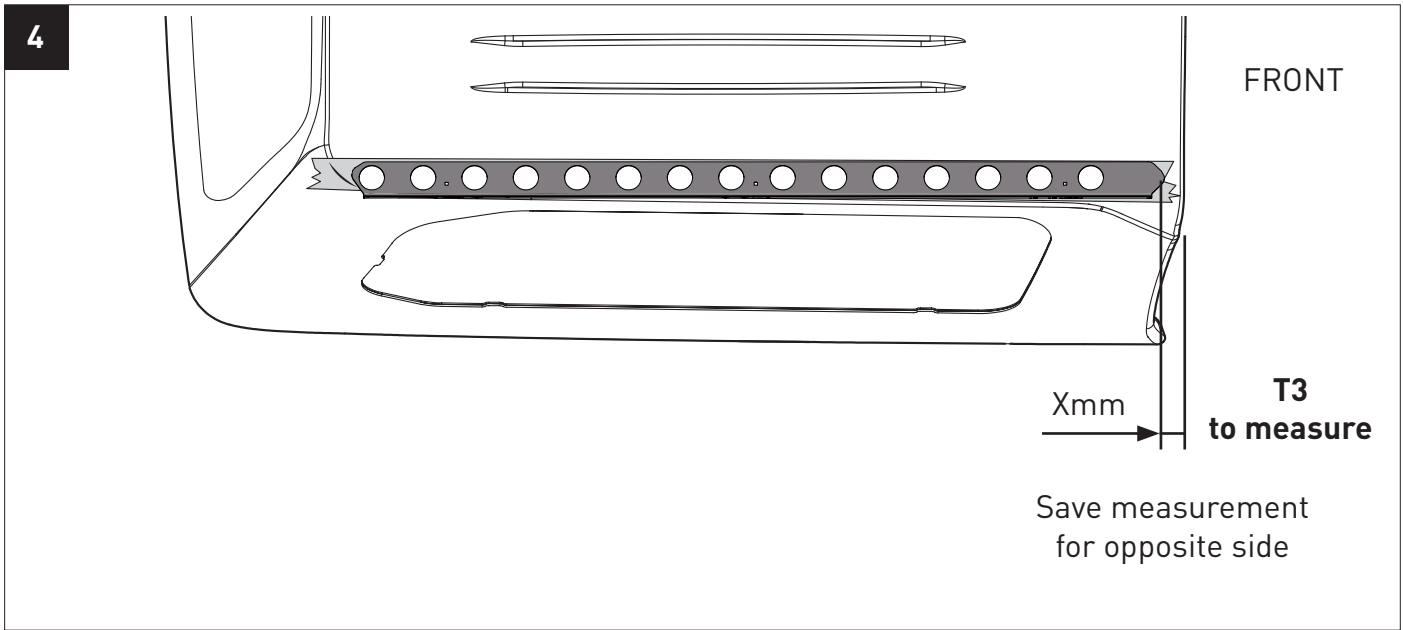

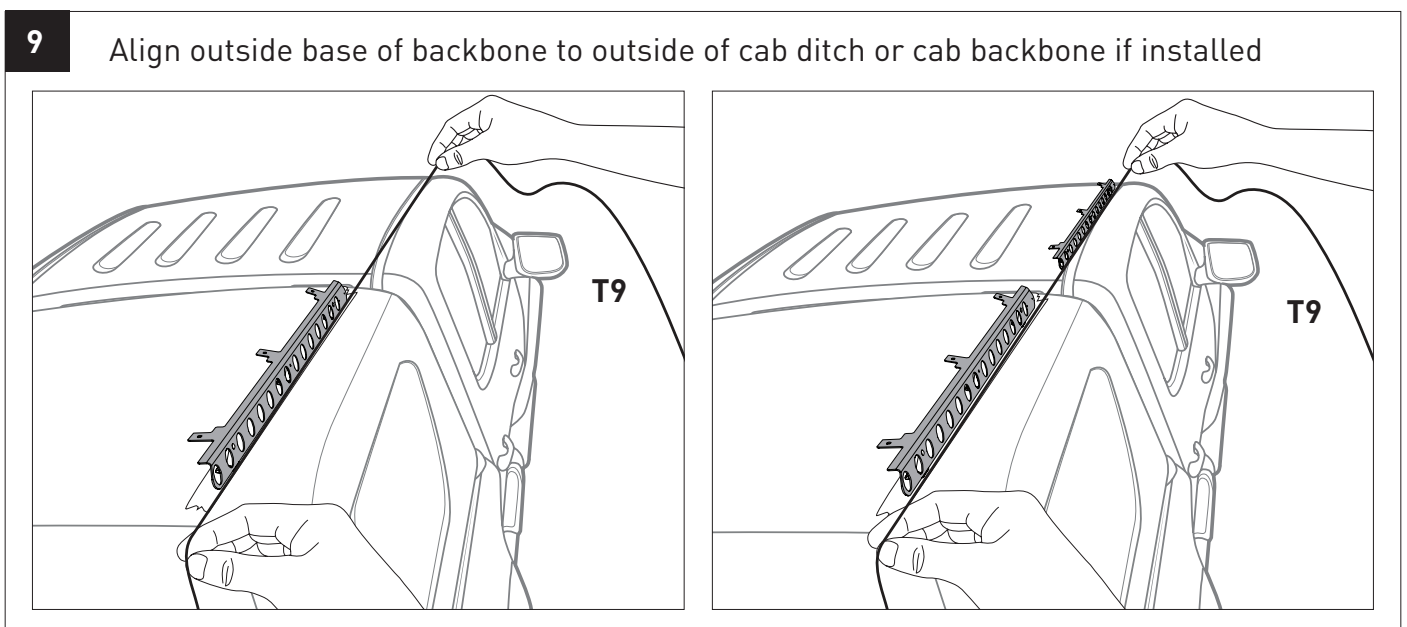
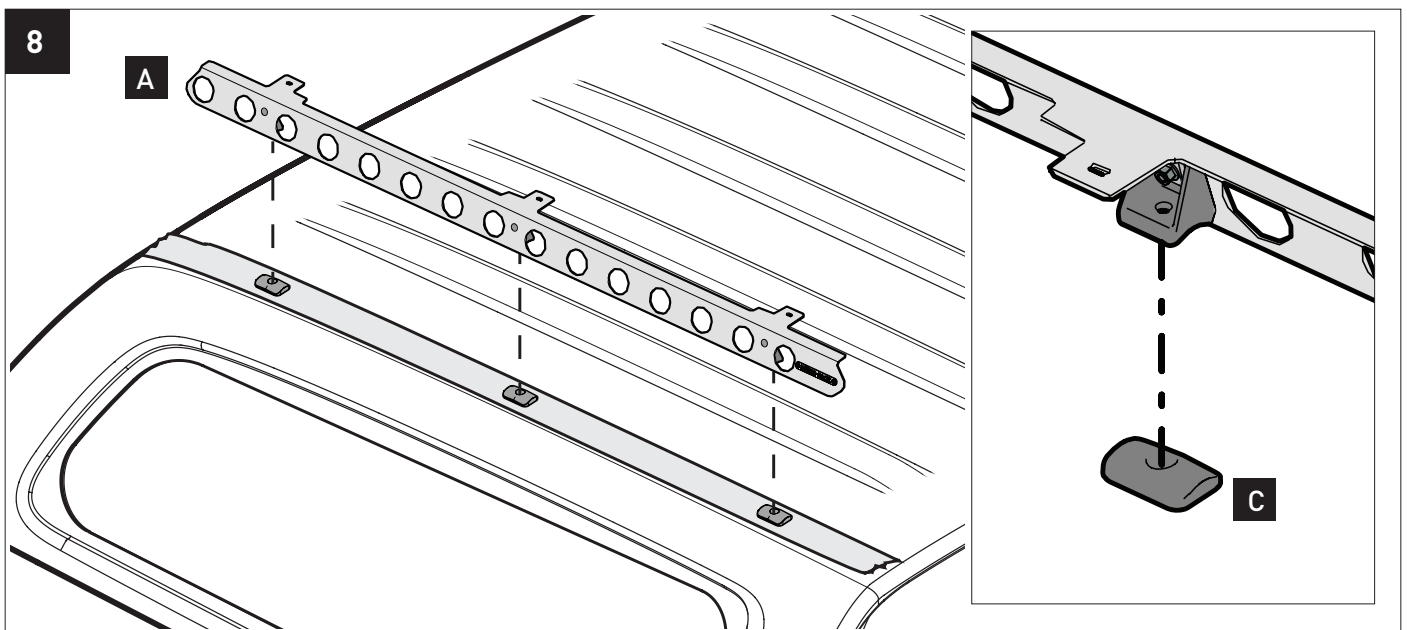
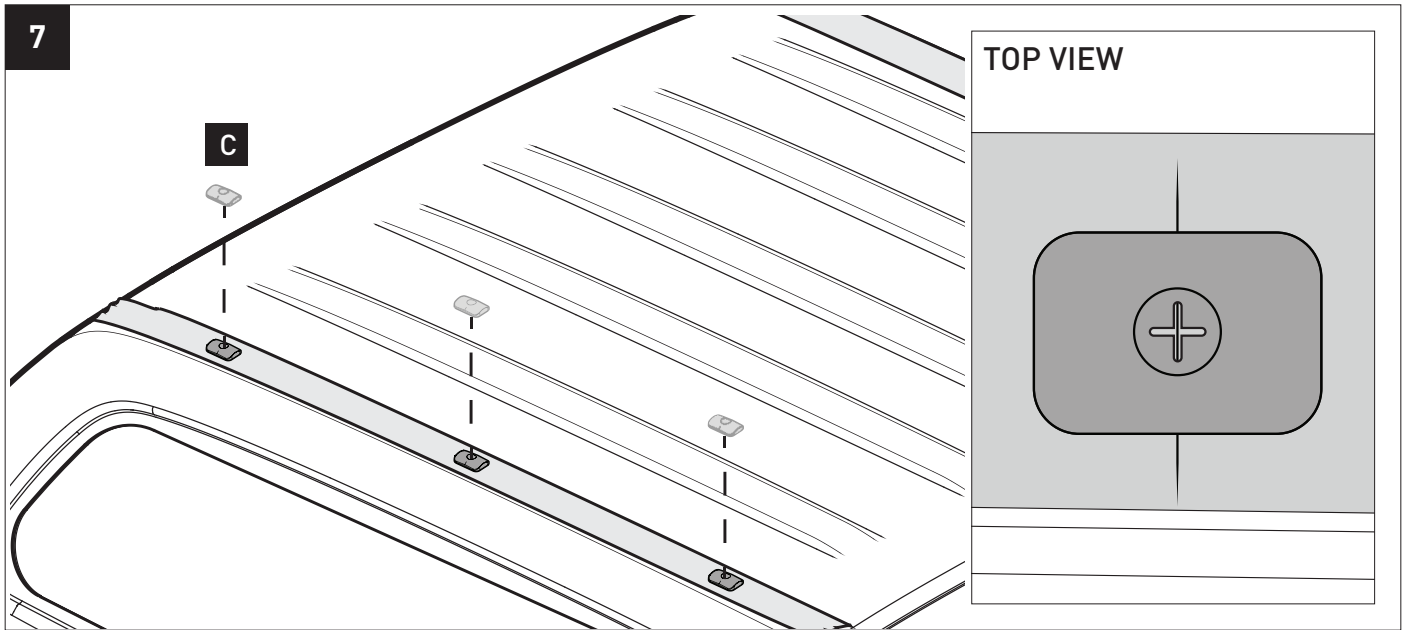

RUMB1 & RUMB2 Backbone Instructions

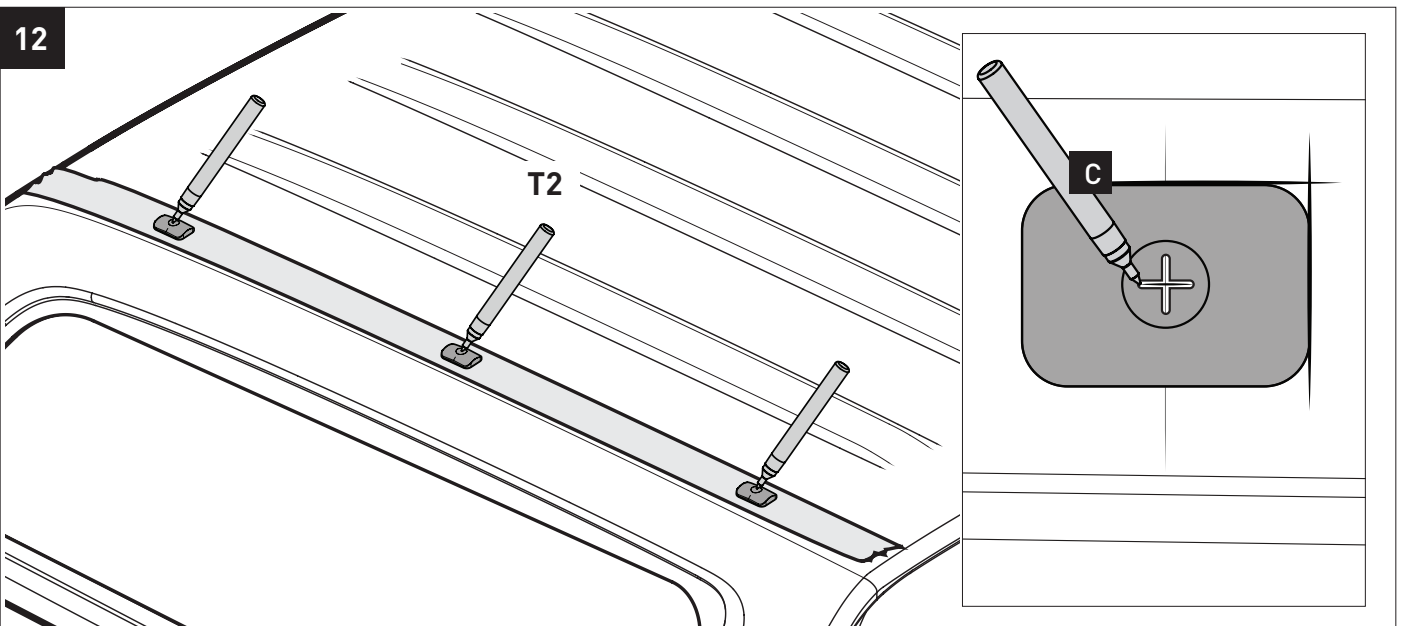
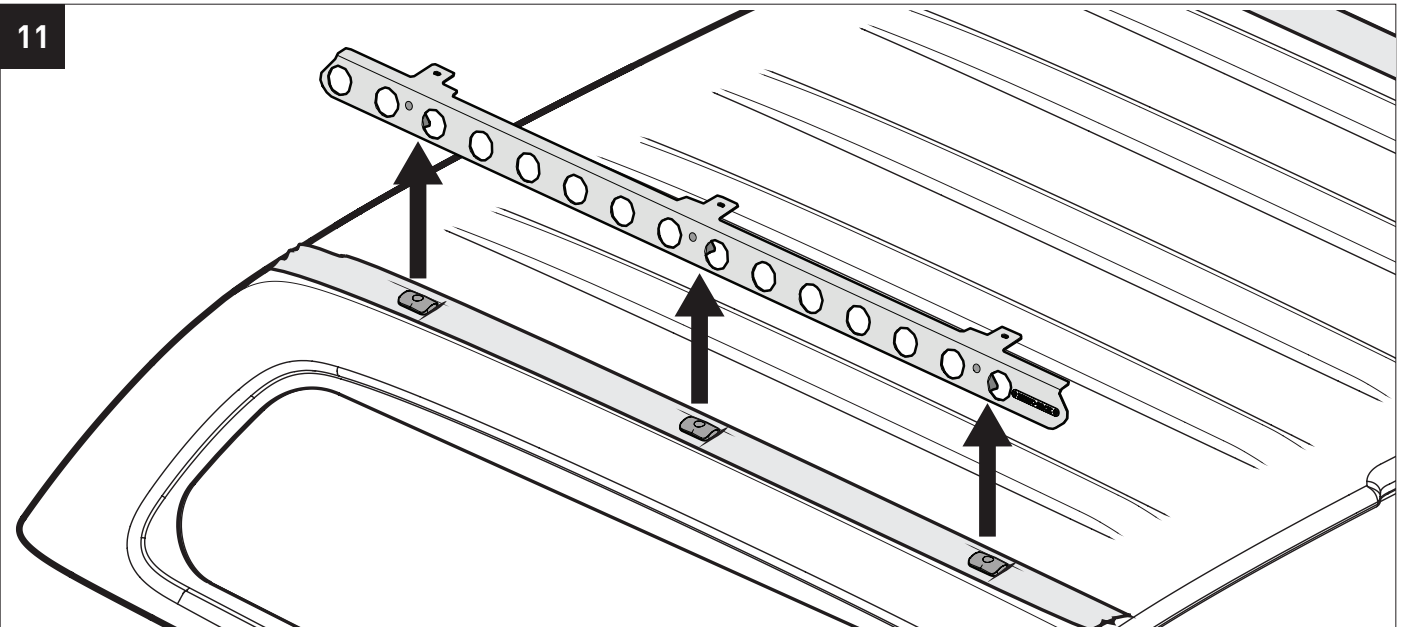
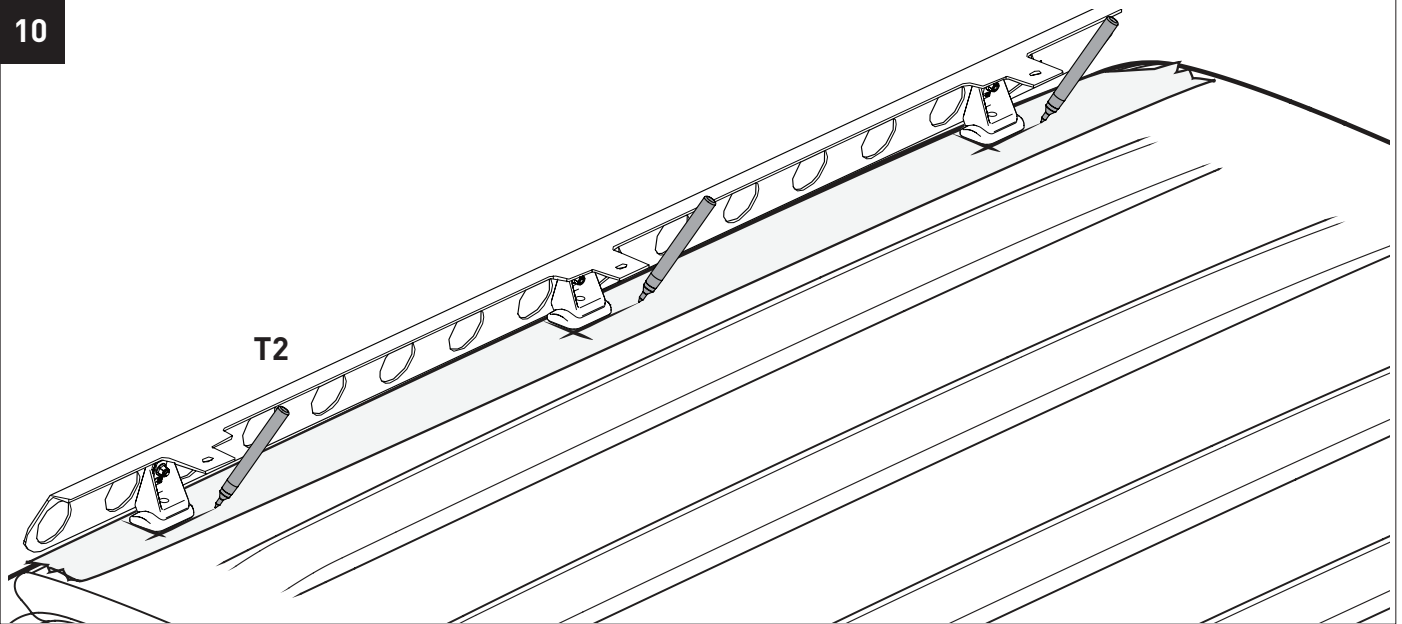

RUMB1 & RUMB2 Backbone Instructions

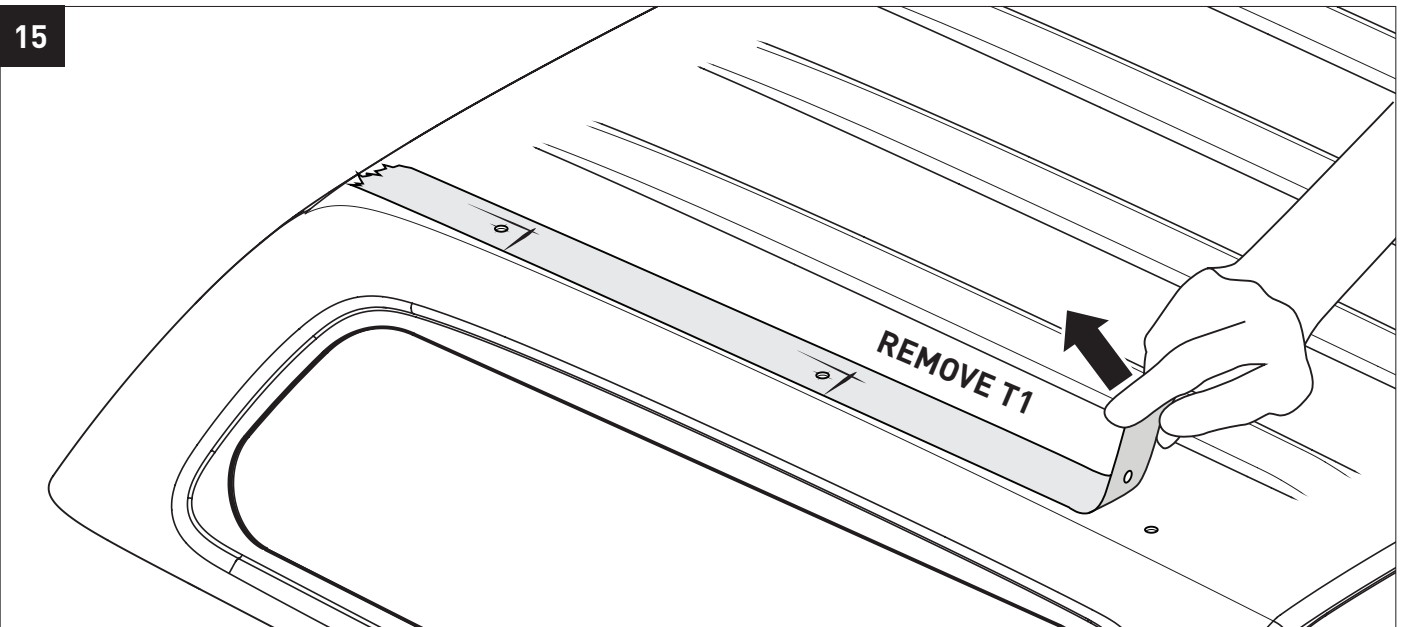
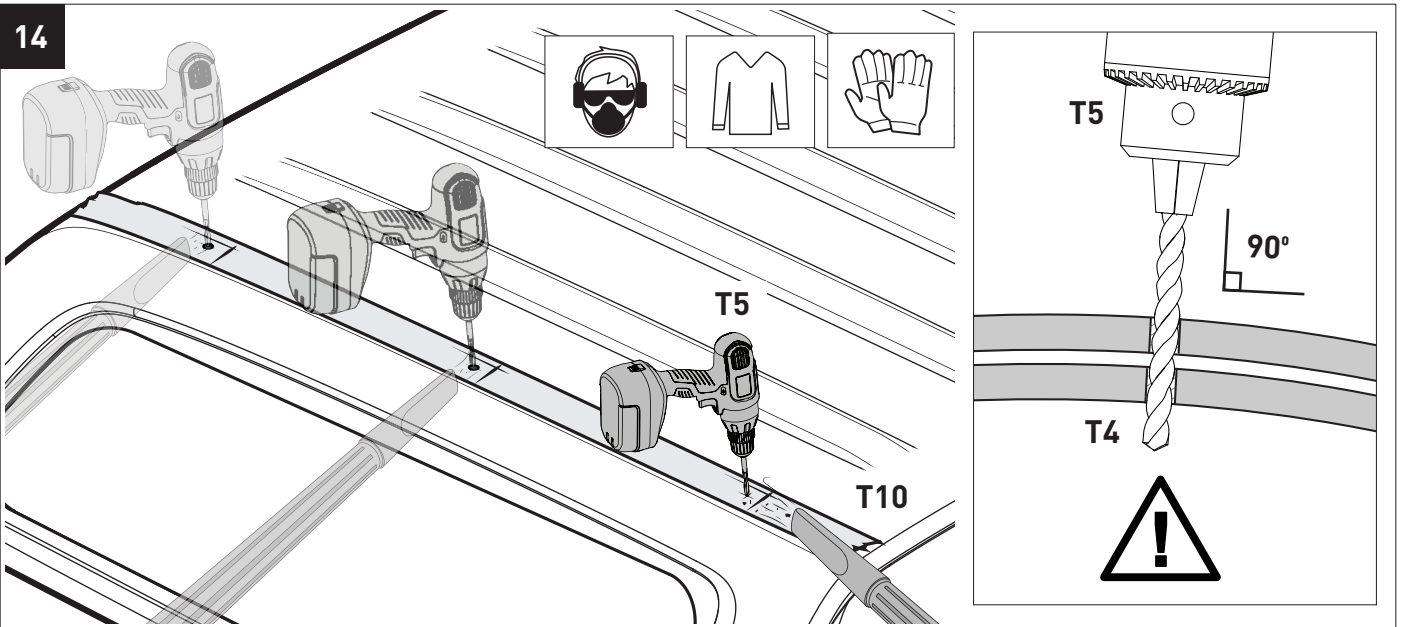
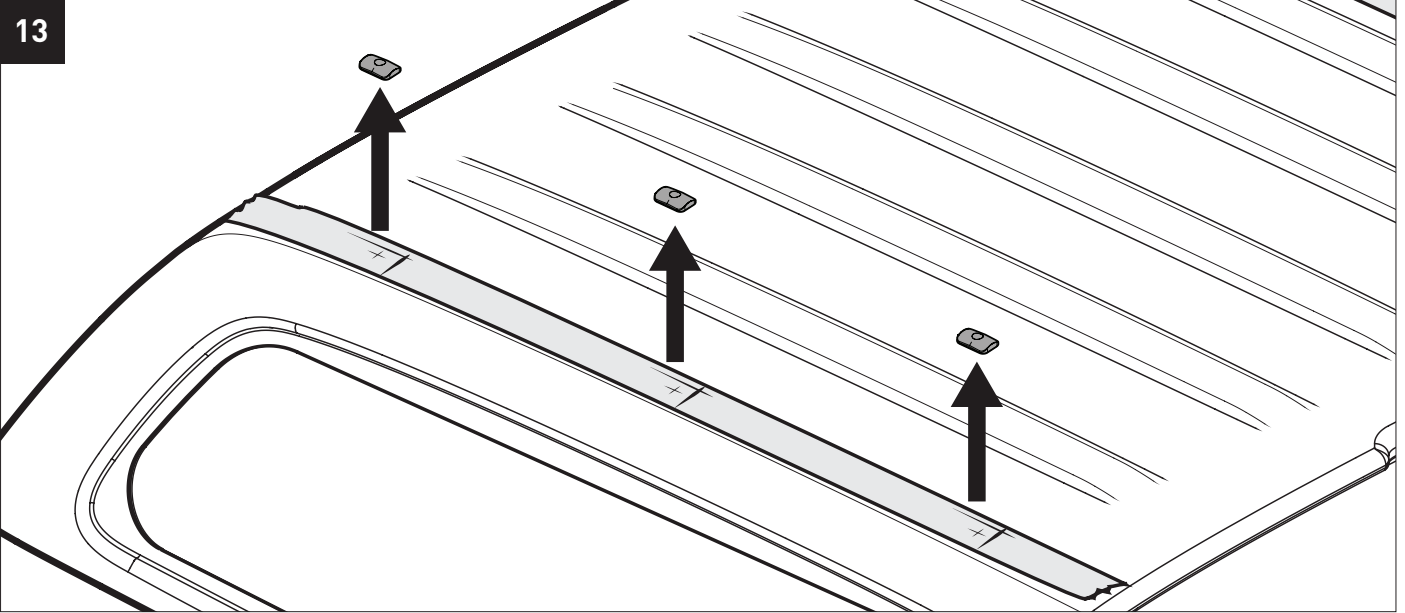

RUMB1 & RUMB2 Backbone Instructions

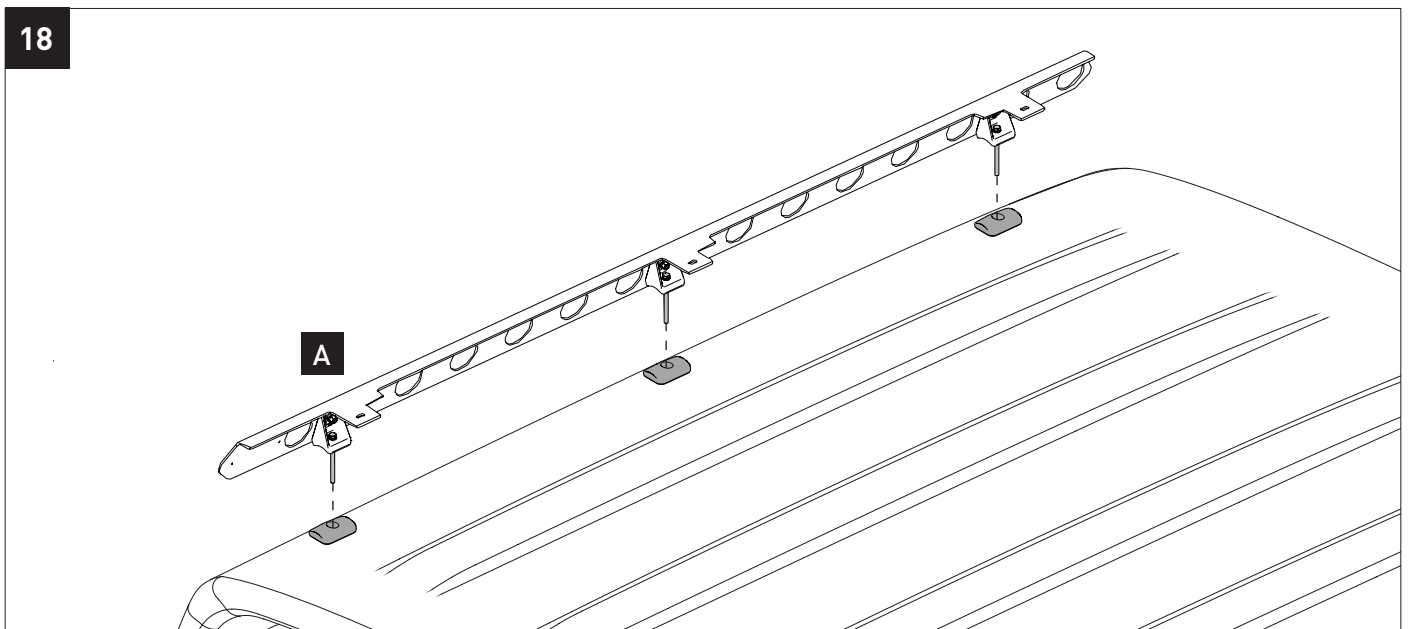
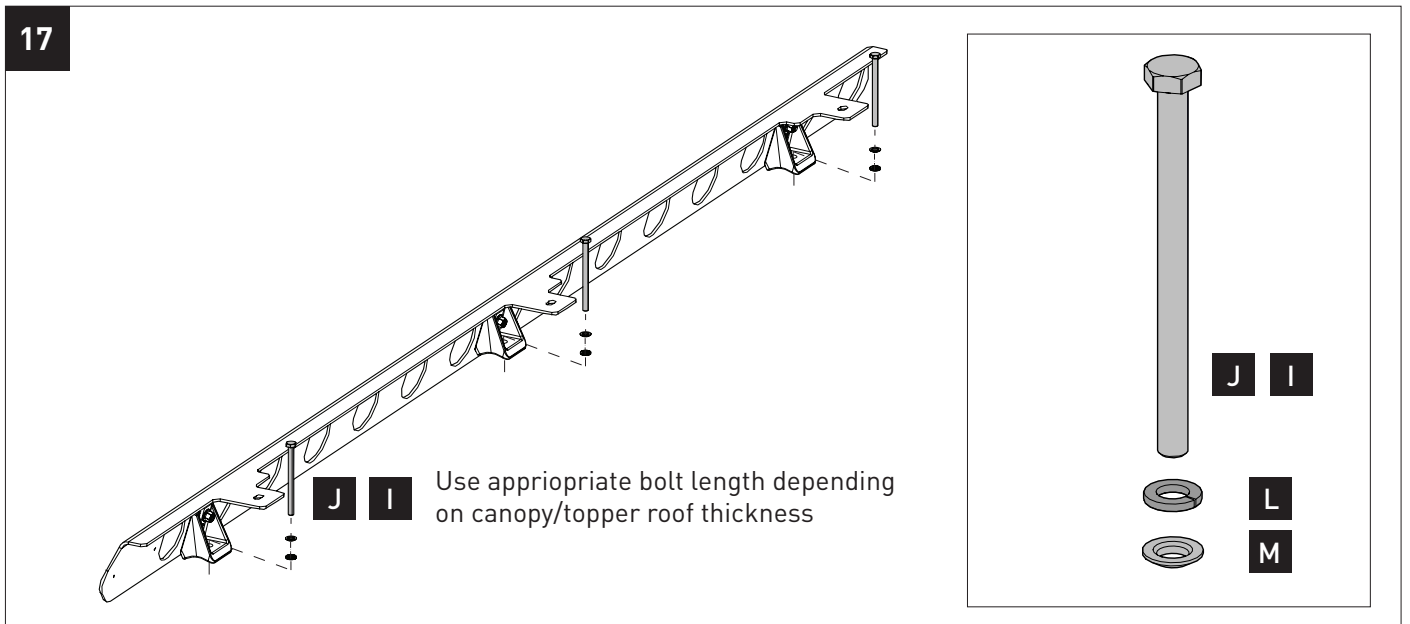
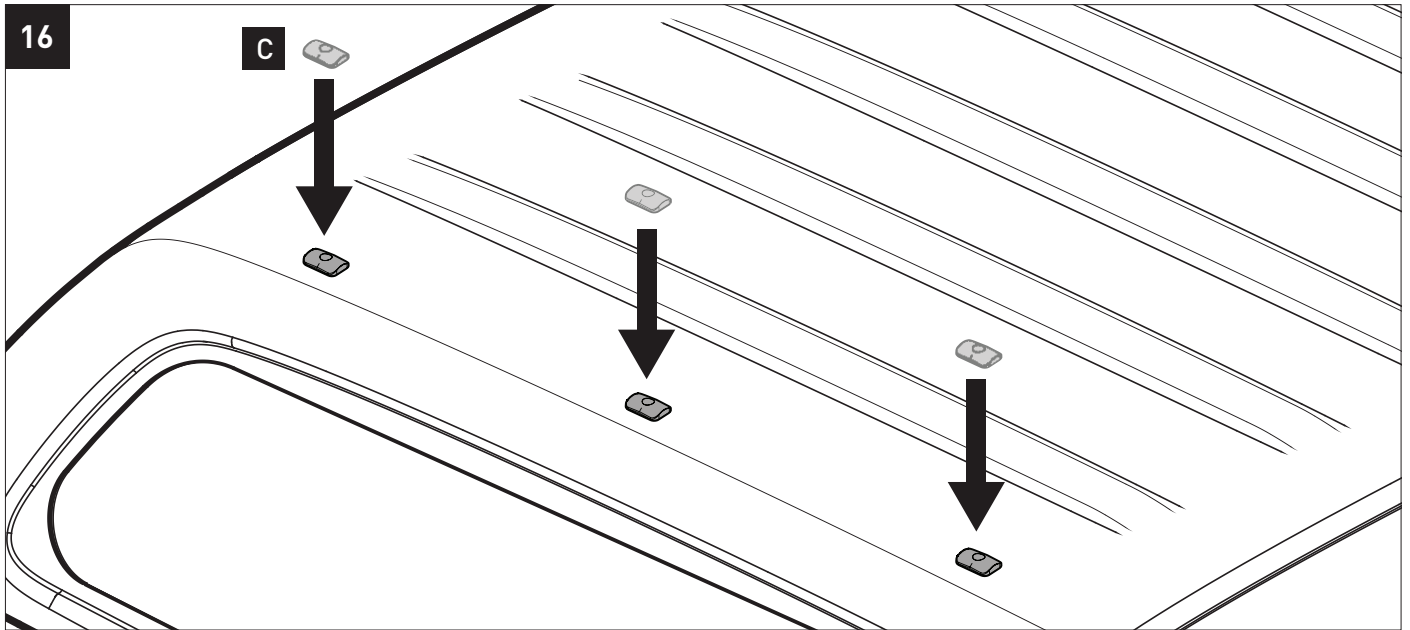

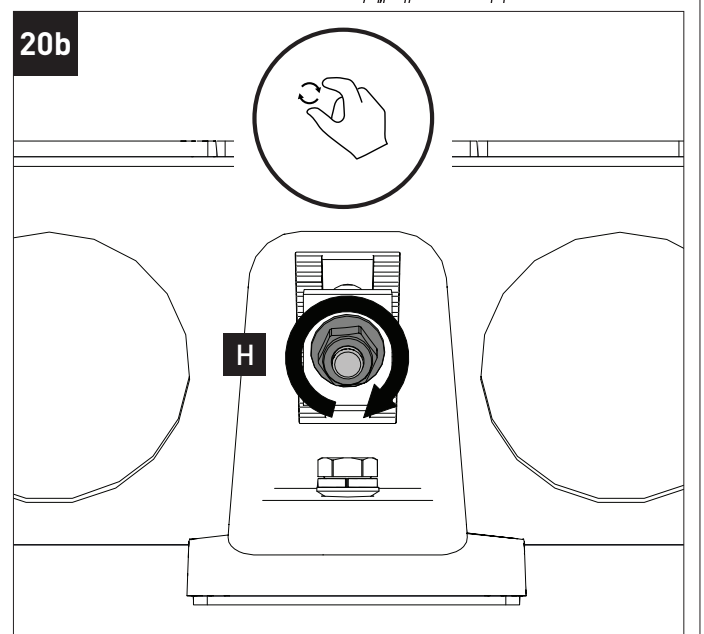
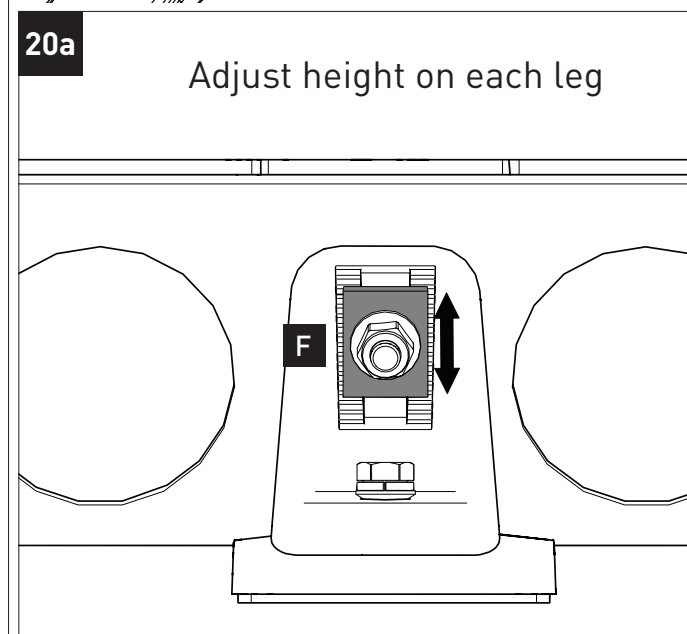
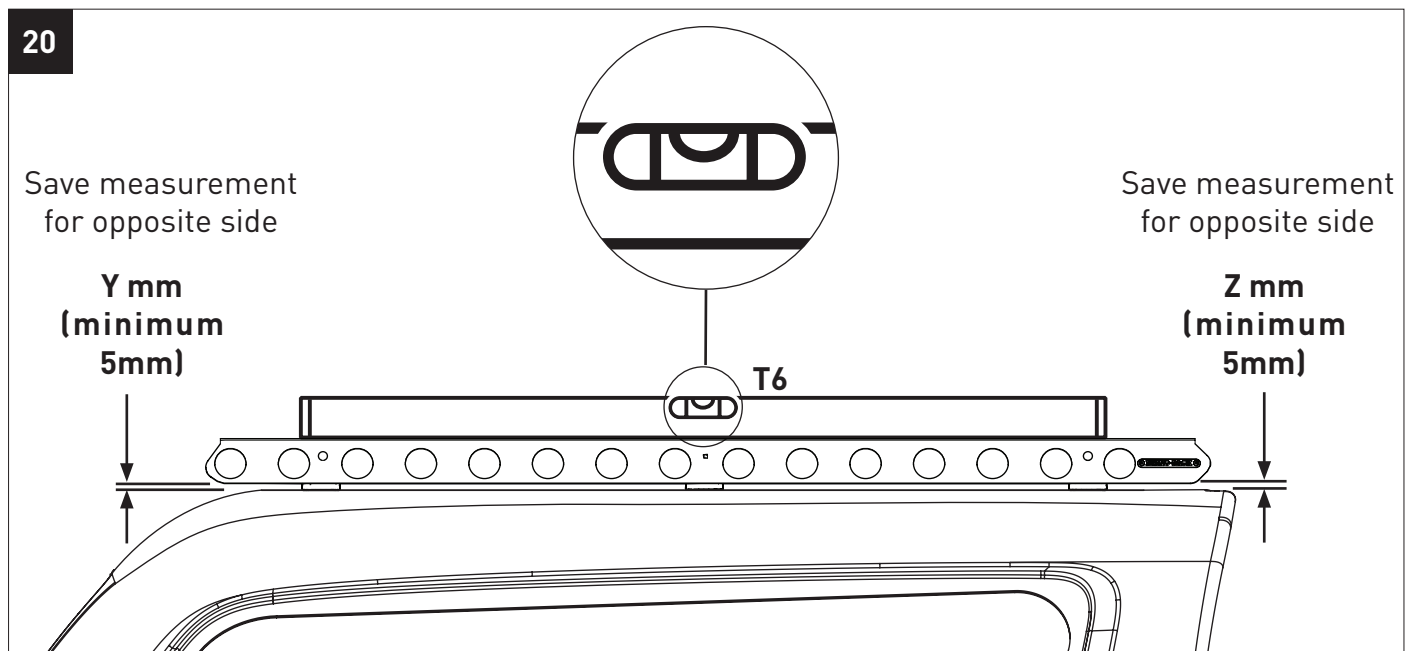
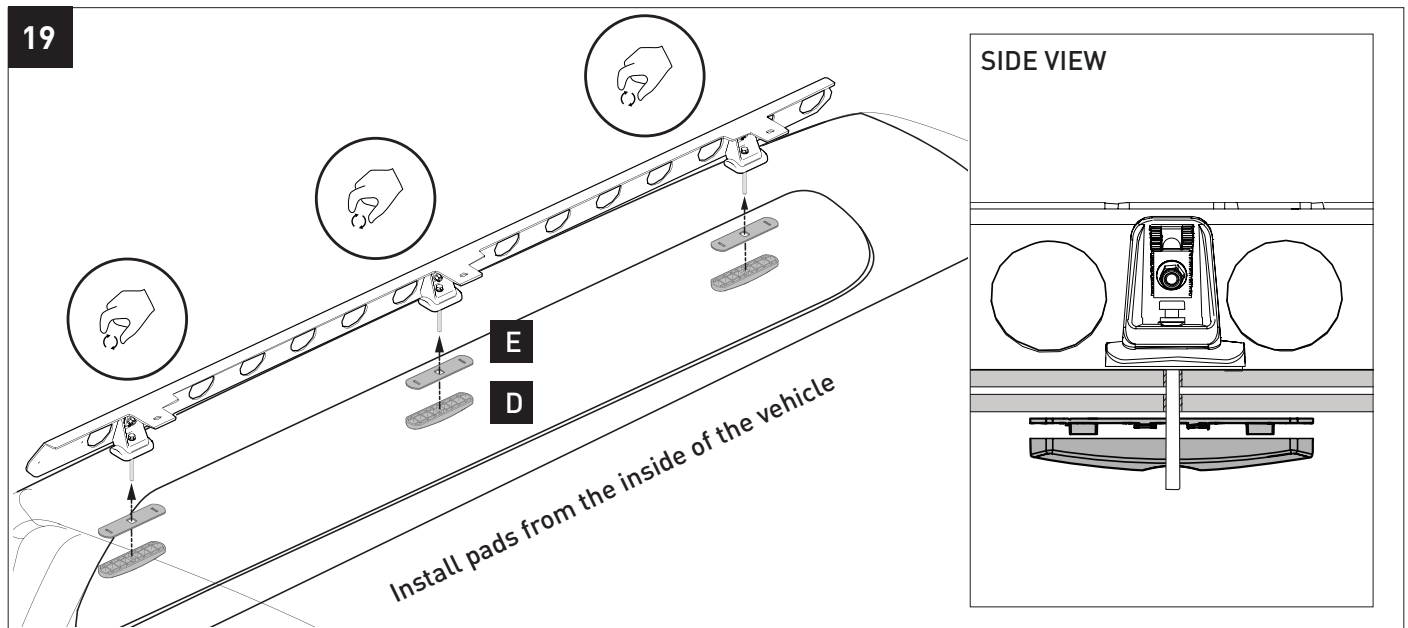

RUMB1 & RUMB2 Backbone Instructions

20c

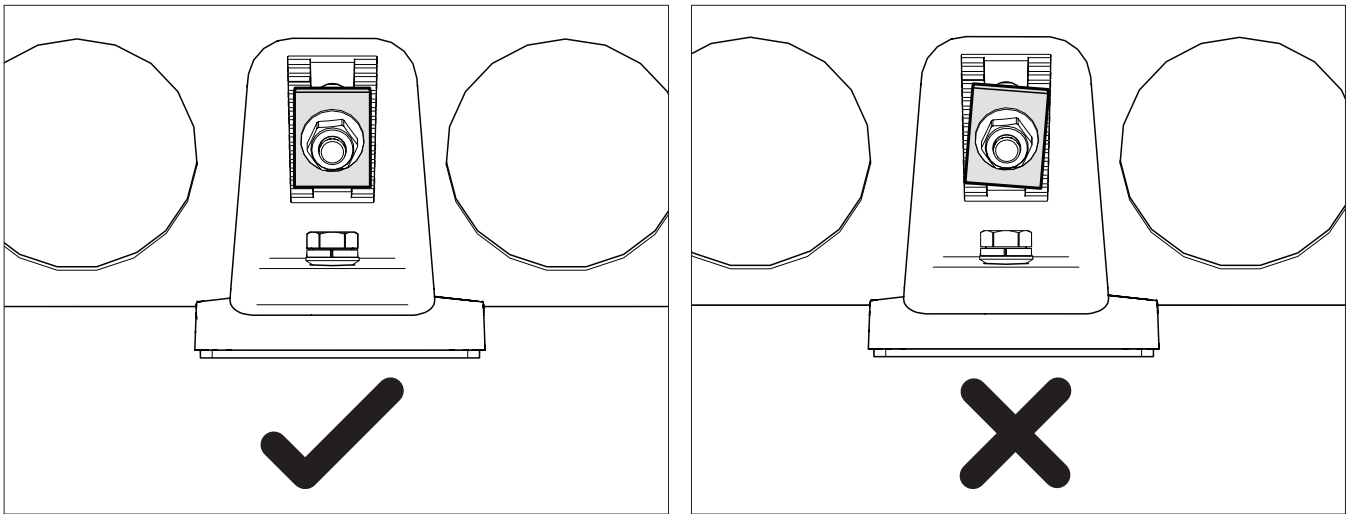

21 Repeat 2 - 20 to opposite side

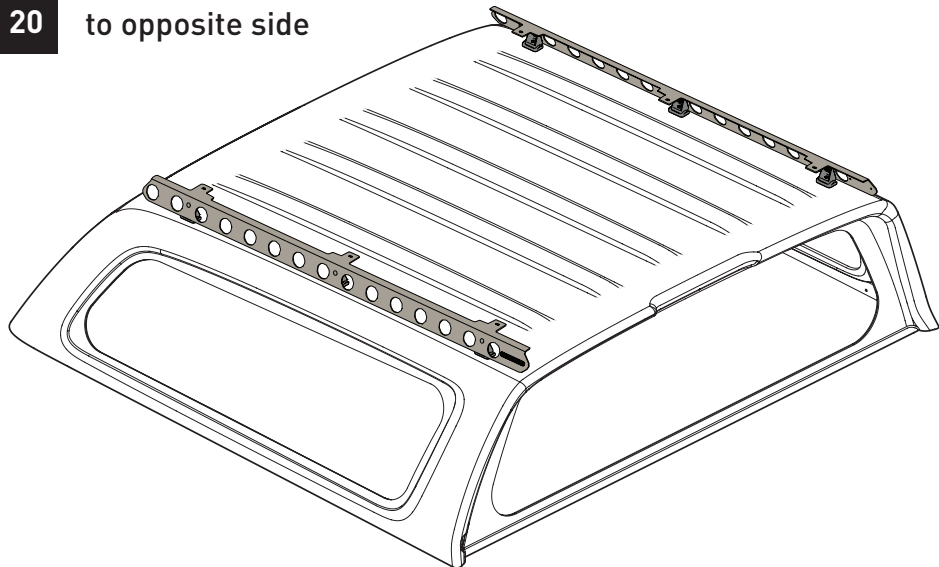

22

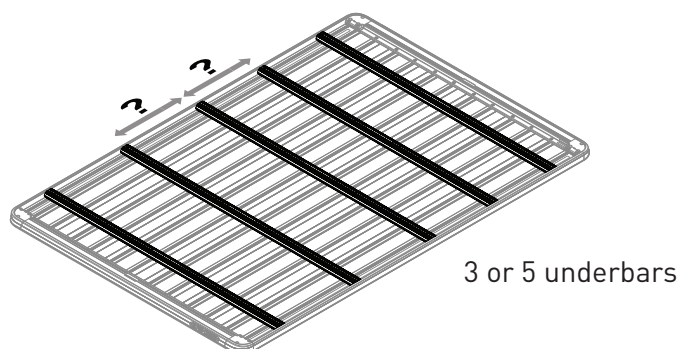

23

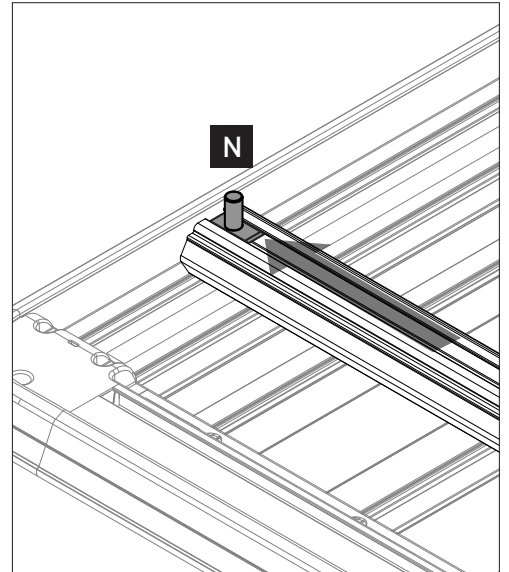
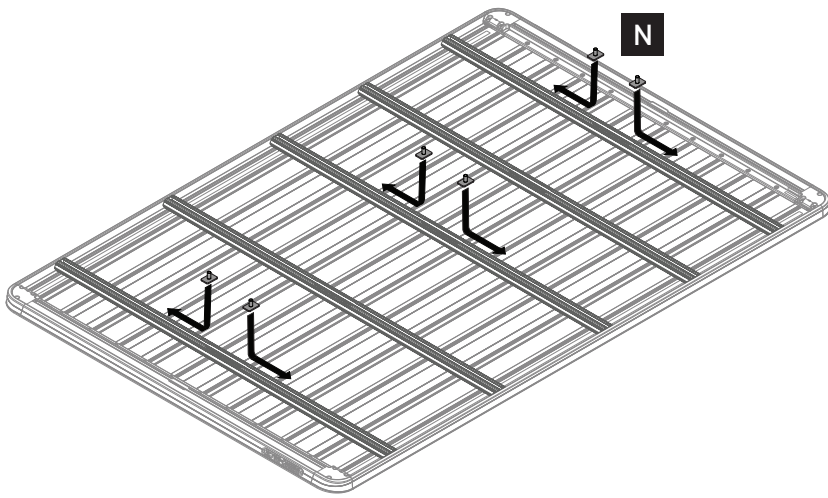

24

Refer **NOTES** on Page 19

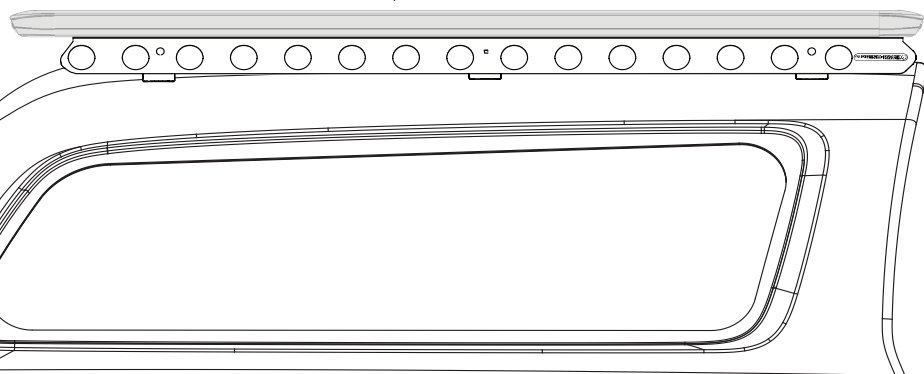
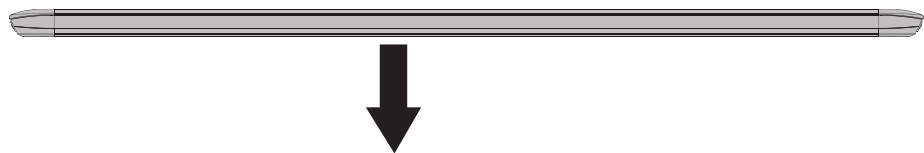

T3

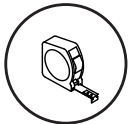

Centre tray on canopy

T3

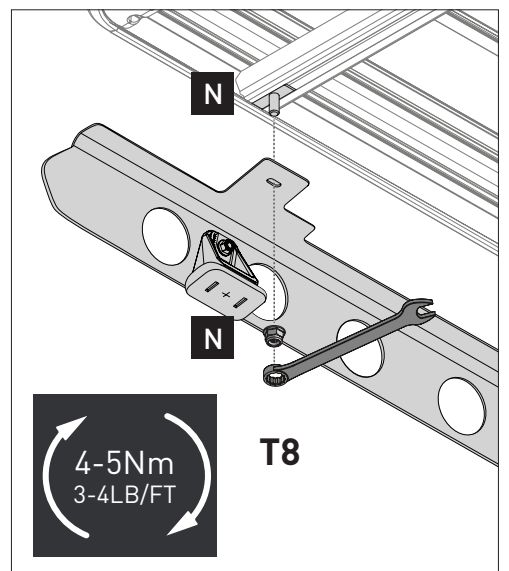
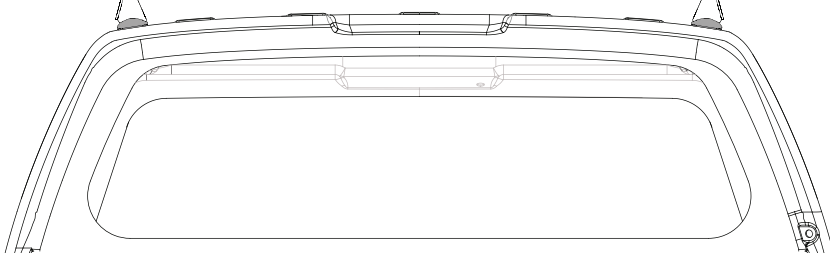
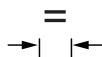
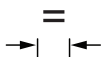
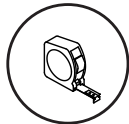

RUMB1 & RUMB2 Backbone Instructions

25

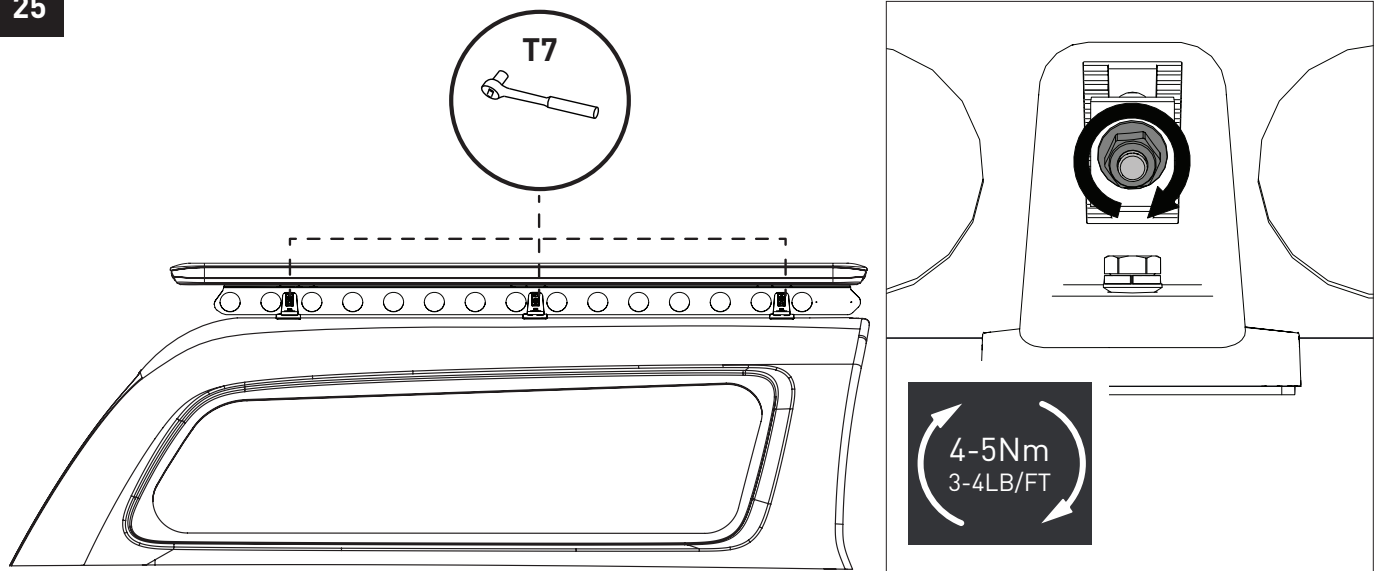

26

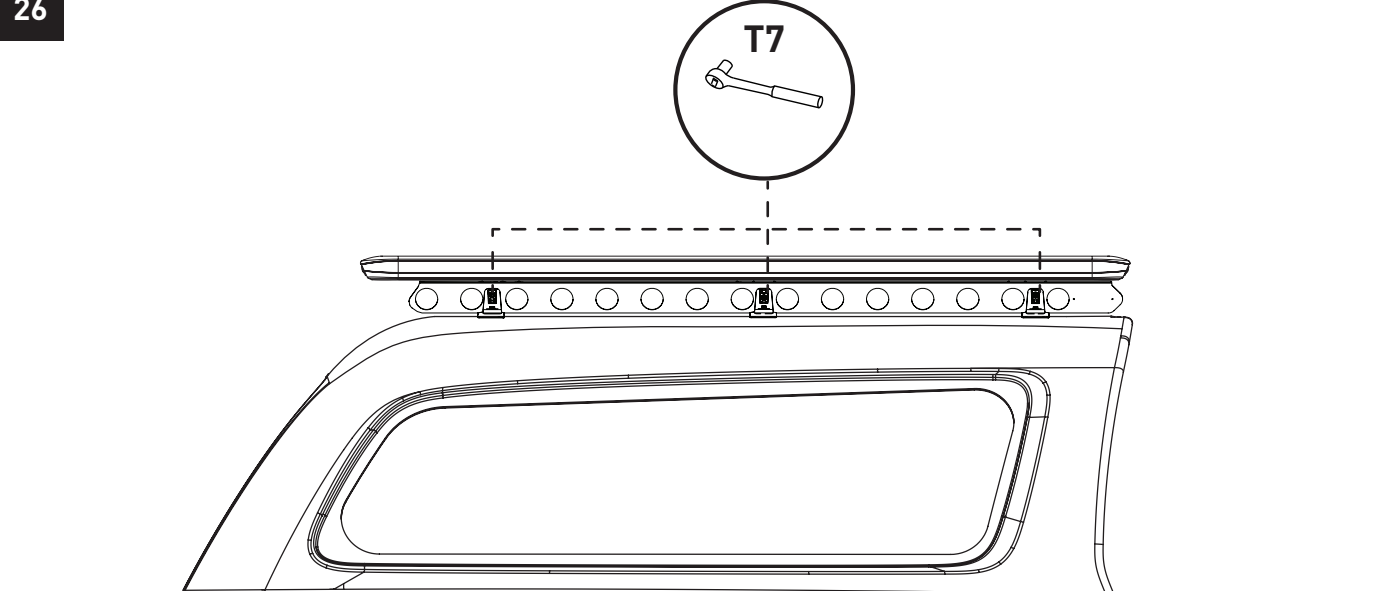

26a

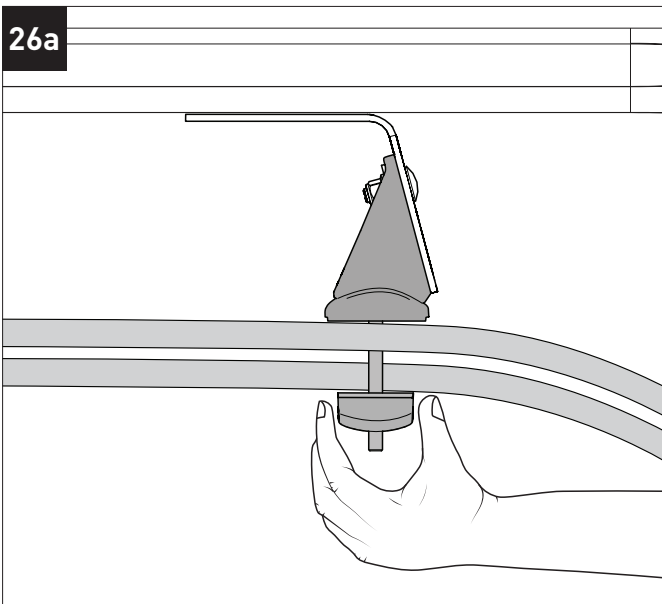

26b

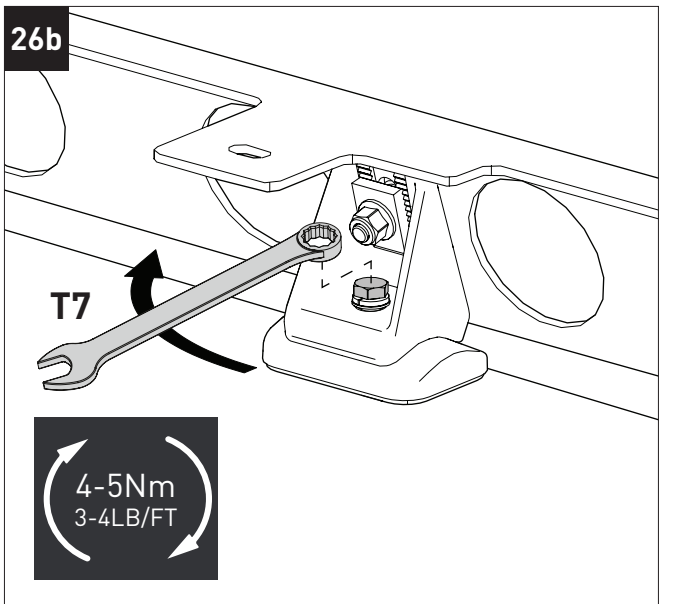

1 TRACK INSTALL

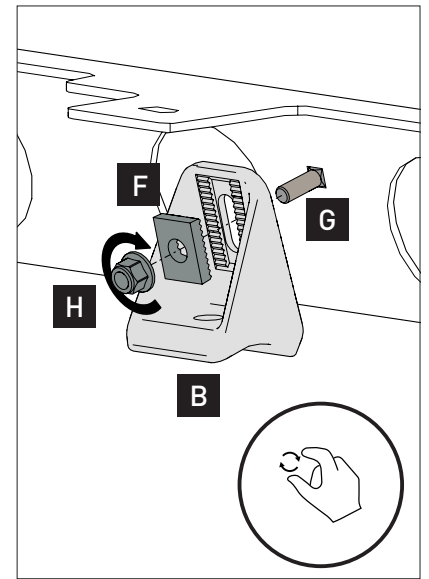
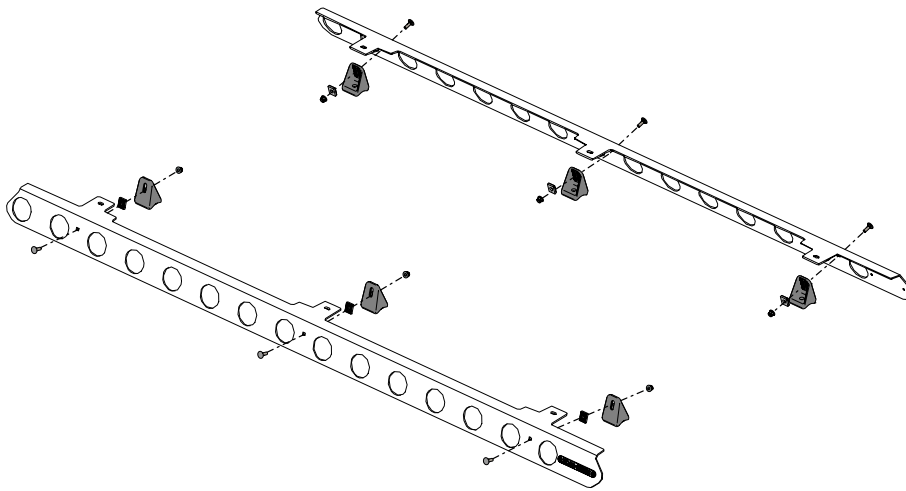

2

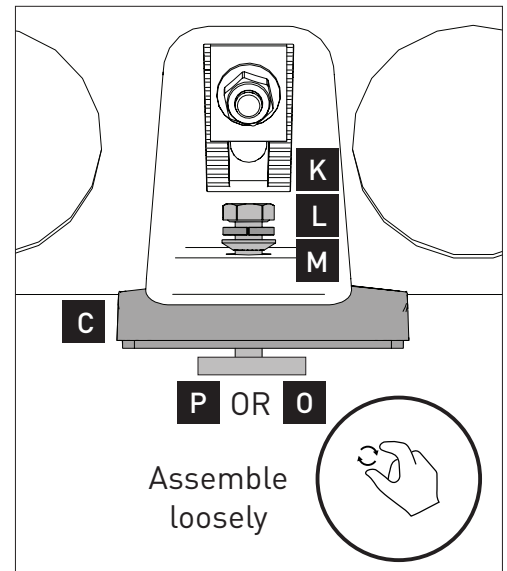
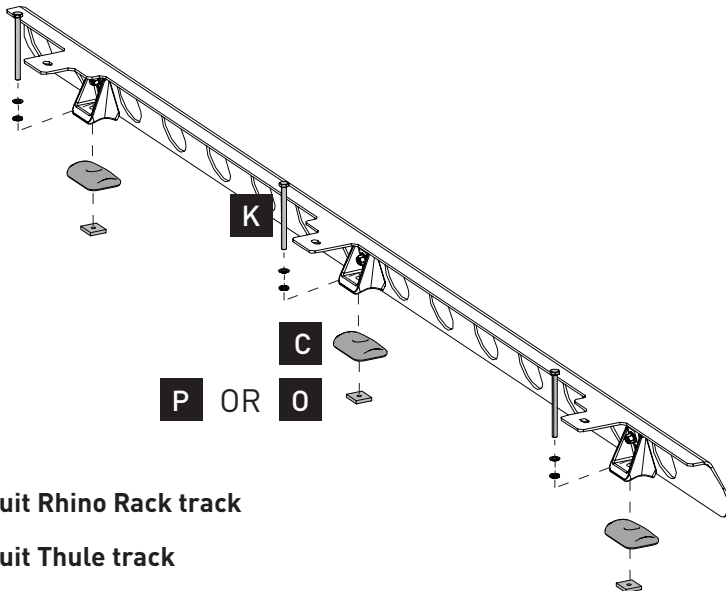

3

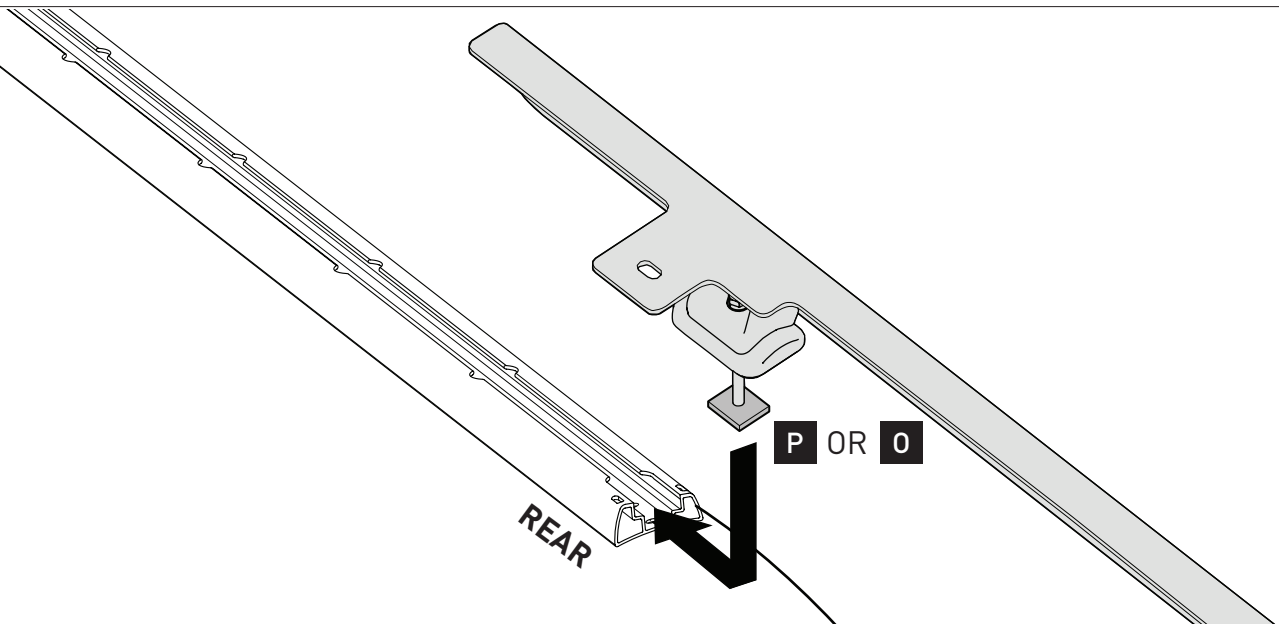

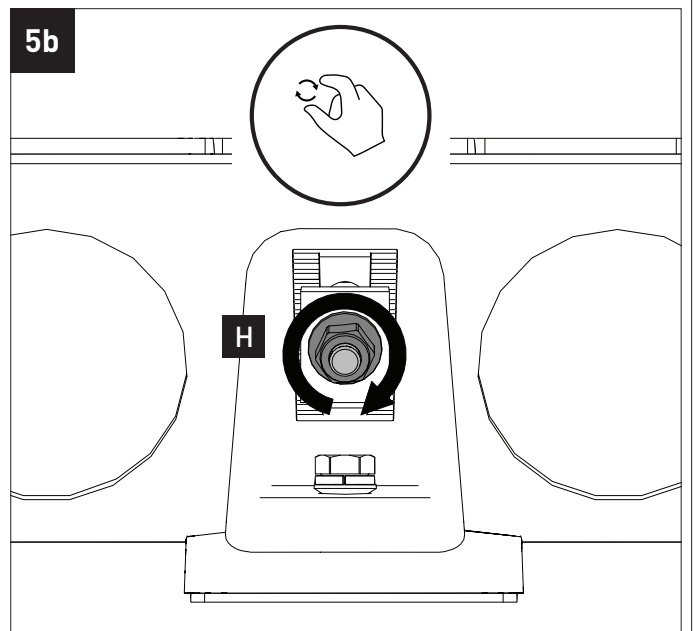
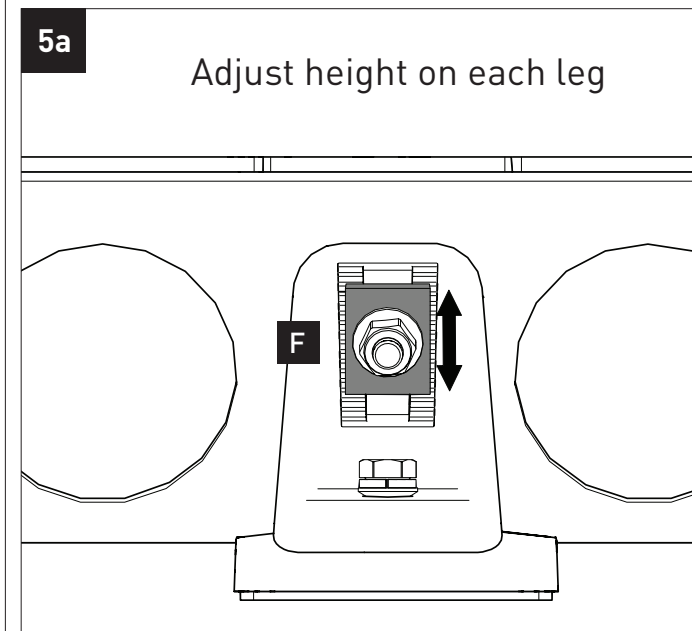
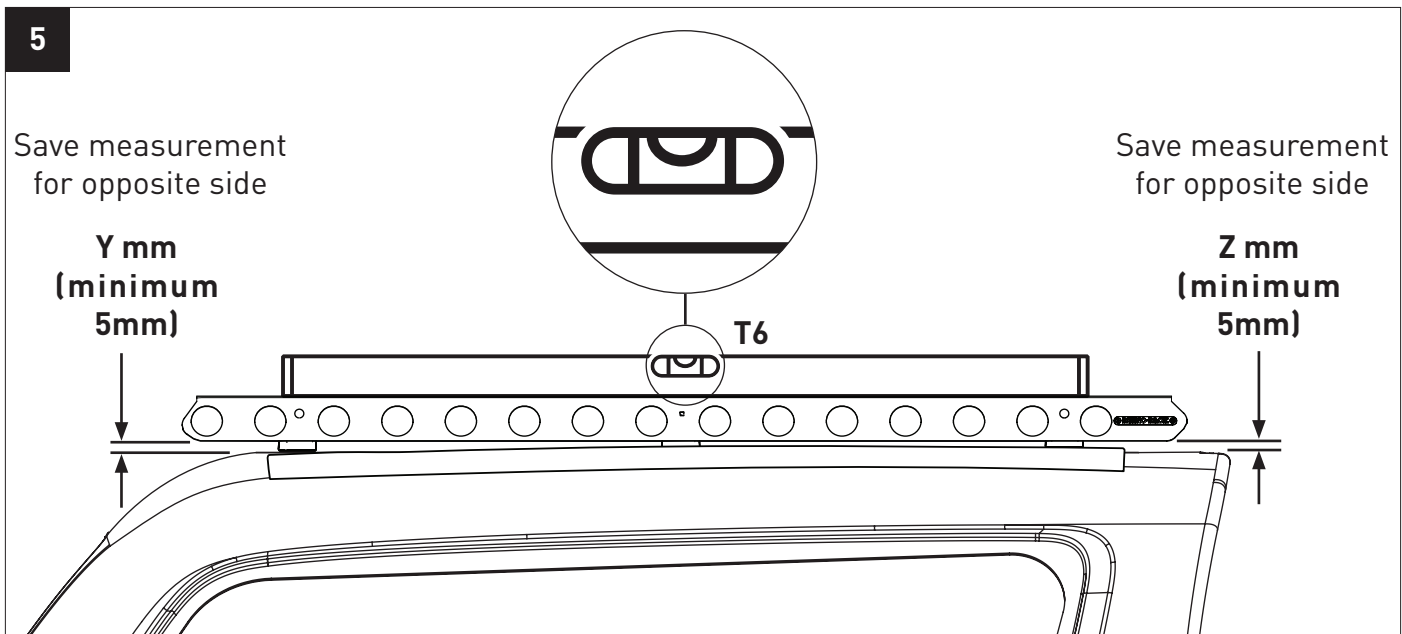
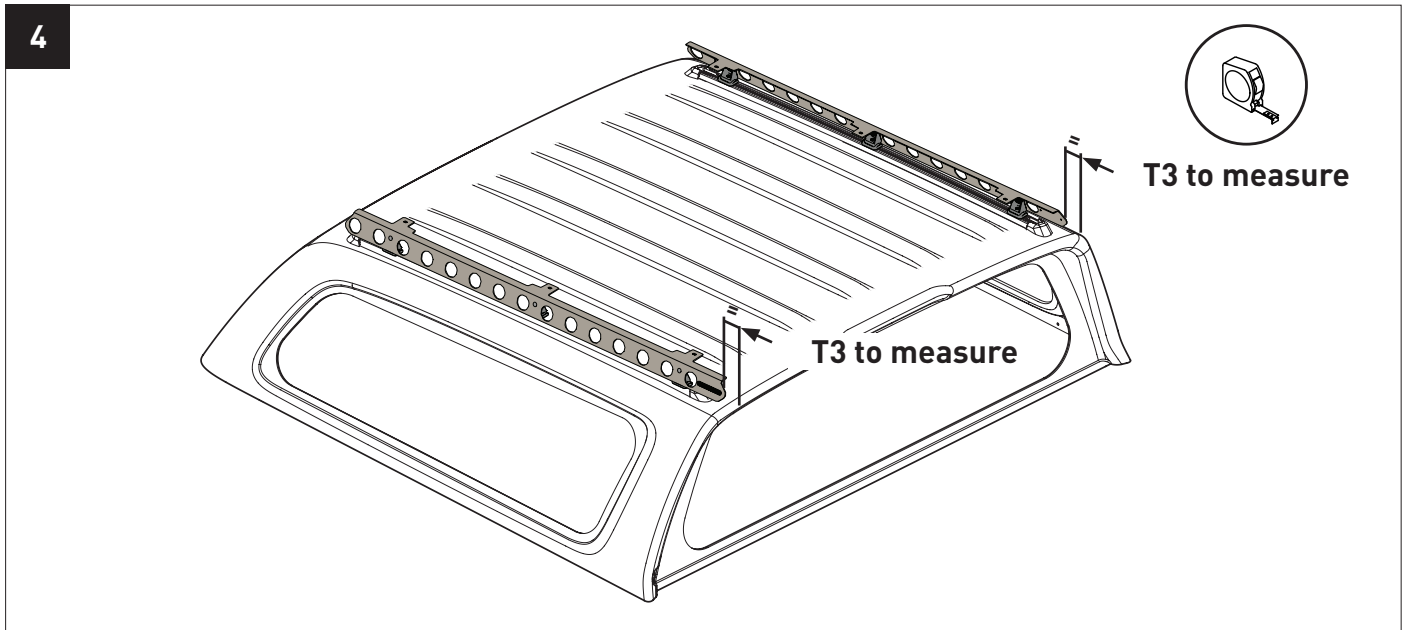

6

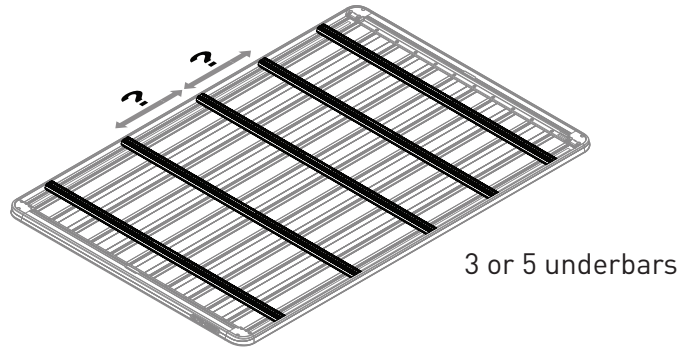

7

Refer **NOTES** on Page 19

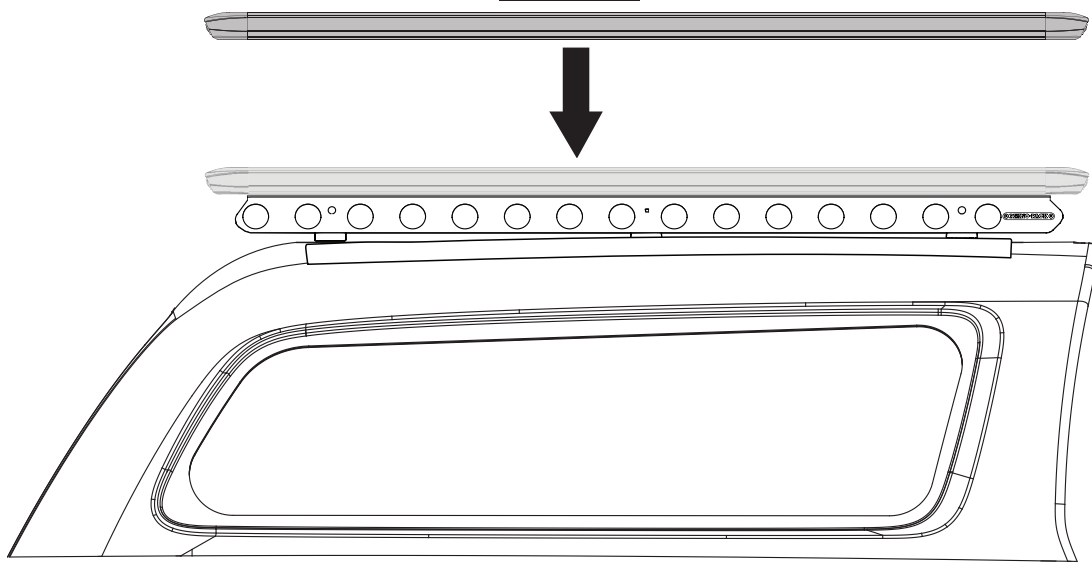

T3 Centre tray on canopy **T3**

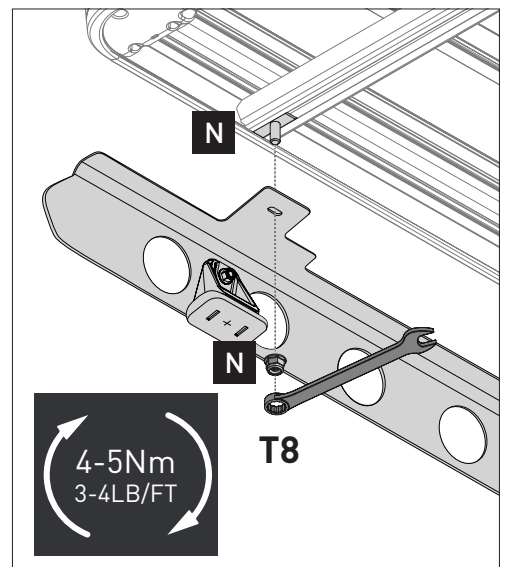
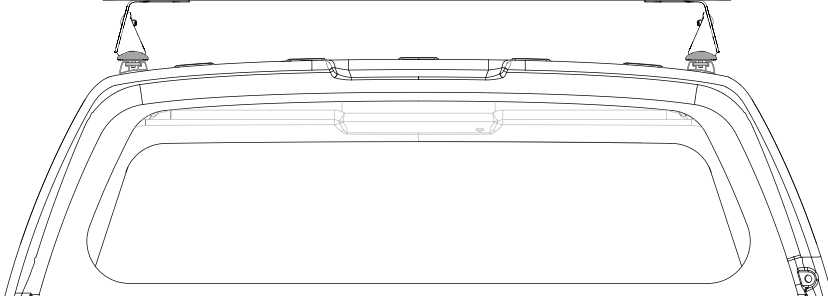
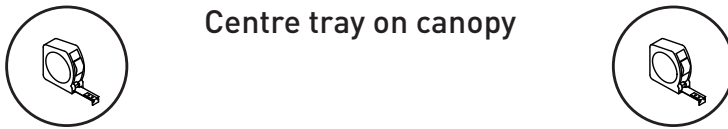

RUMB1 & RUMB2 Backbone Instructions

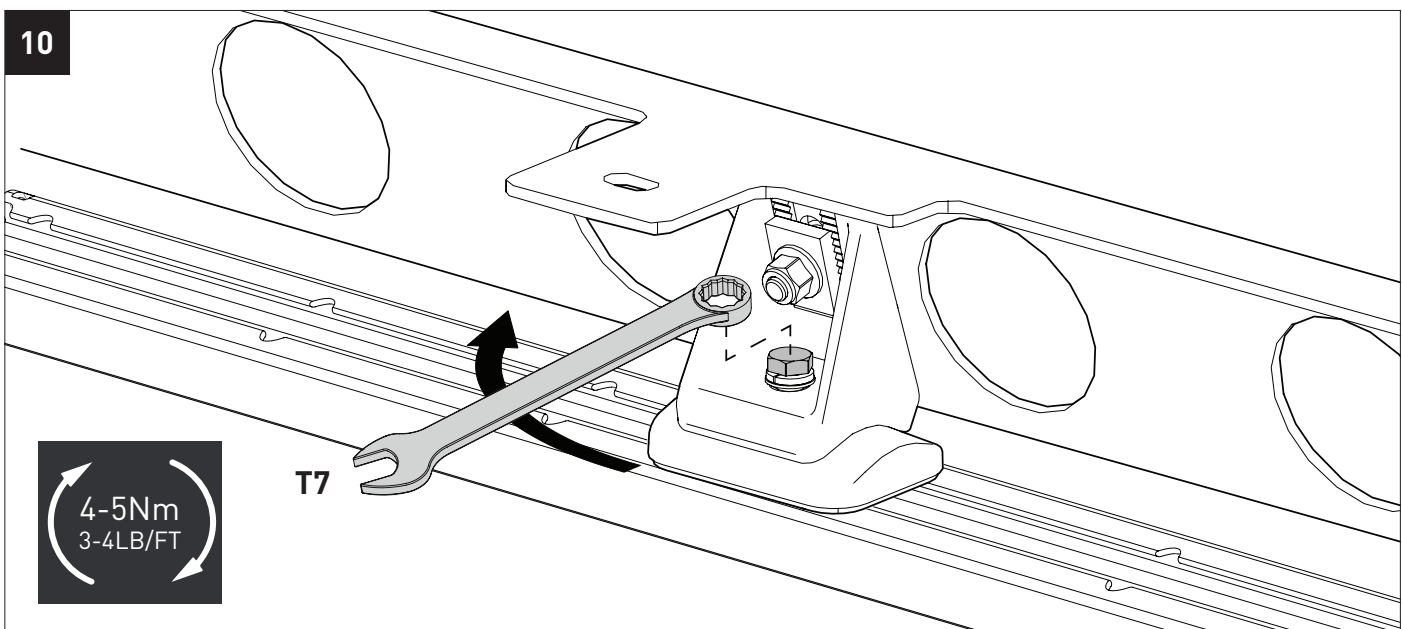
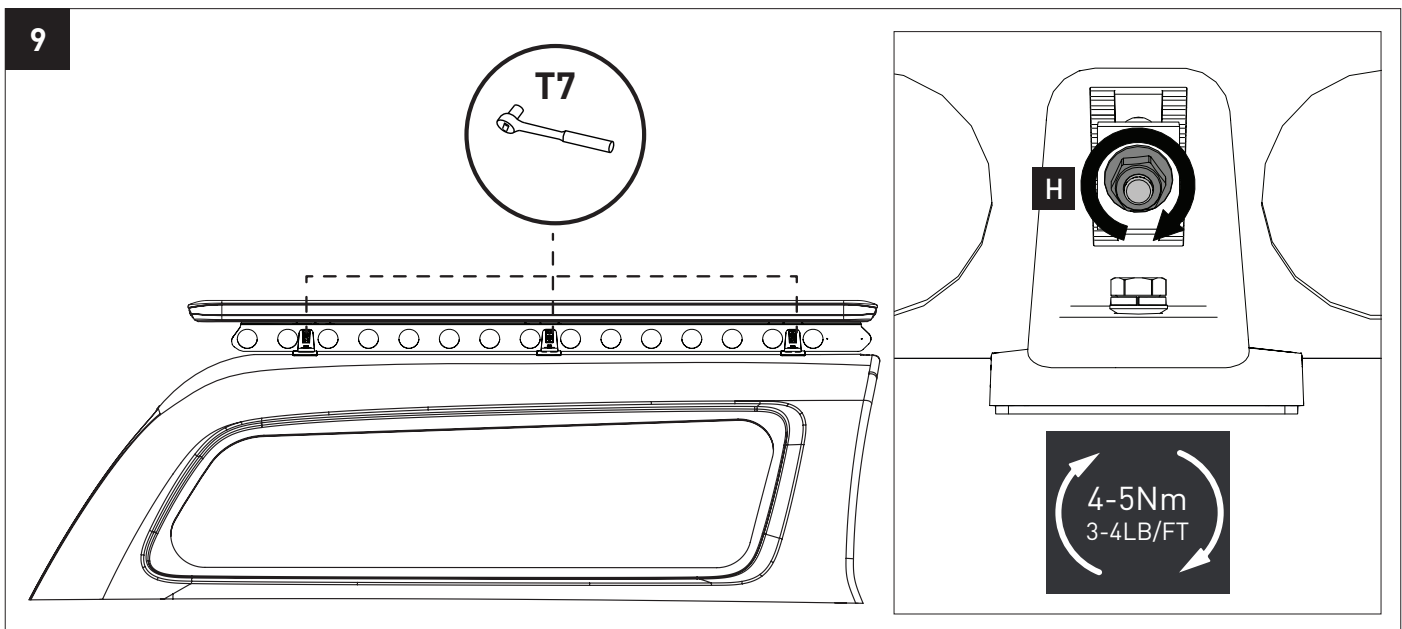
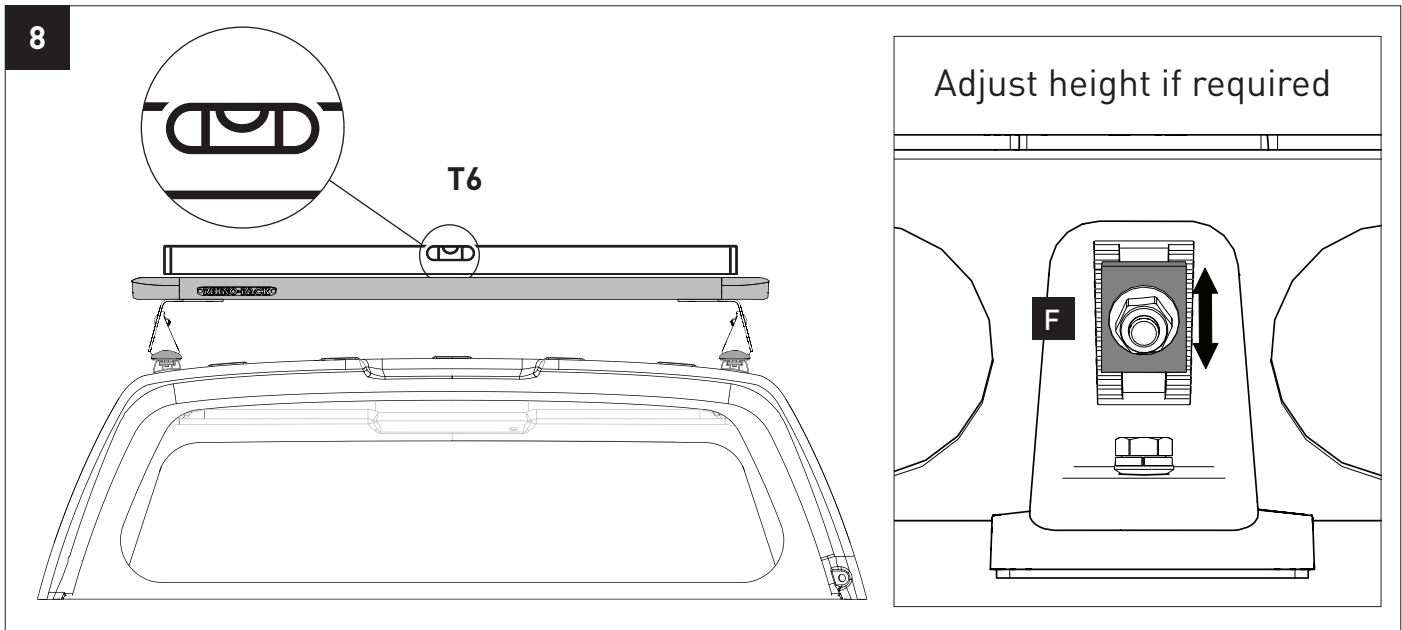

RUMB1 & RUMB2 Backbone Instructions

NOTES

