

# RHINO-RACK

## Toyota Tacoma Backbone - RTTB1

Fit Time: 1 Hour

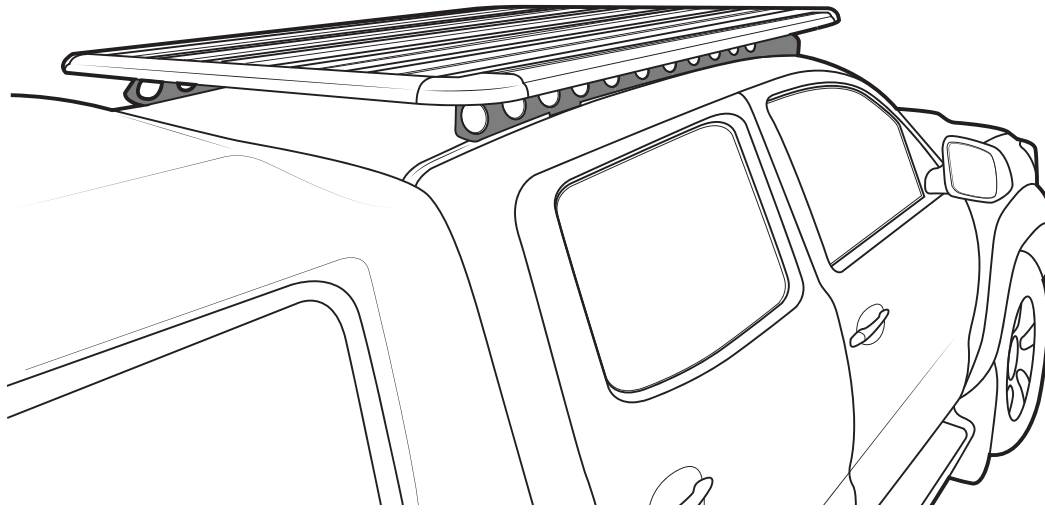

### Important Information

#### Maximum carrying capacity:

Suitable Pioneers	On Road Cargo Allowance	Off Road Cargo Allowance	Static Allowance	Roof Allowance	Rack Weight
42100B	74.5kg / 164lb	54.5kg / 120lb	334.5kg / 737lb	100kg / 220lb	25.5kg / 56lb
45100B	72.5kg / 160lb	52.5kg / 116lb	332.5kg / 733lb		27.5kg / 61lb
41100	70kg / 155lb	50kg / 110lb	330kg / 728lb		30kg / 66lb
42101B	71.5kg / 158lb	51.5kg / 114lb	331.5kg / 731lb		28.5kg / 63lb
45101B	69.5kg / 153lb	49.5kg / 109lb	329.5kg / 726lb		30.5kg / 67lb
41101	67kg / 148lb	47kg / 104lb	327kg / 721lb		33kg / 73lb

**Roof Allowance:** Total permissible weight attached to the roof of the car. This is inclusive of the weight of the roof rack system

**Cargo Allowance:** Total permissible weight allowed on top, and attached to roof racks whilst the vehicle is in motion

**Static Allowance:** Total permissible weight allowed on top, and attached to roof racks whilst the vehicle is stationary

Please refer to your vehicle manufacturers handbook for maximum carrying capacity. Always use the lower of the two figures. Load must be evenly distributed over the entire Pioneer. Weight of roof rack accessories is to be included in cargo allowance.

#### Torque settings

Unless stated otherwise in these instructions, all fasteners should be set to the following torque settings -

M6: 4-5Nm (3-4lbs/ft), M8: 8-10Nm (6-7.5lbs/ft) and M10: 16-18Nm (12-13lbs/ft).

#### Warning:

- Check Part No. and/ or Kit is correct for use with your vehicle
- Do not attempt to fit the rack system to your vehicle unless you fully understand these fitting instructions. Please direct any questions regarding fitting to the dealer from where the roof racks were purchased.
- **Use only non-stretch fastening ropes or straps.**
- The handling characteristics of the vehicle changes when you transport a load on the roof. For safety reasons we recommend you exercise extreme care when transporting wind-resistant loads. Special consideration must be taken into account when cornering and braking.
- Although the system is tested and approved to AS1235-2000 / ISO 11154, off-road conditions can be much more rigorous. Extreme care must be taken in off road conditions

# Toyota Tacoma Backbone - RTTB1

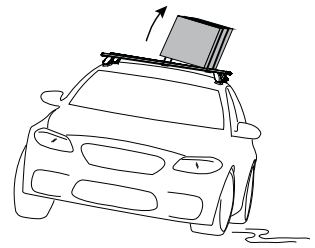
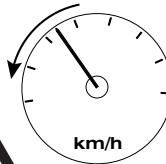
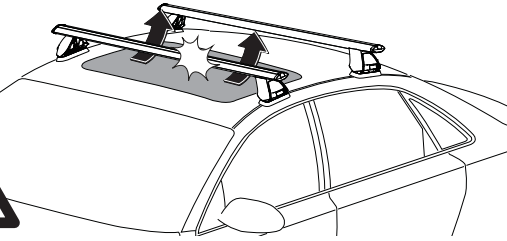
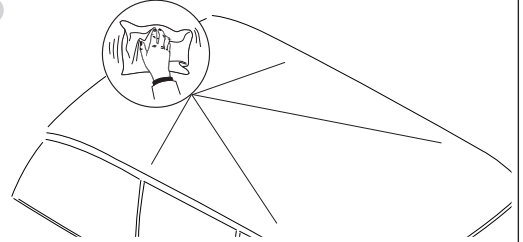
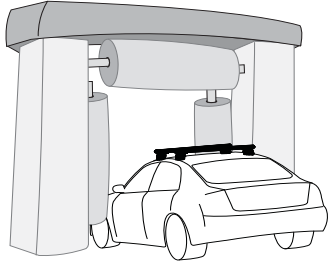
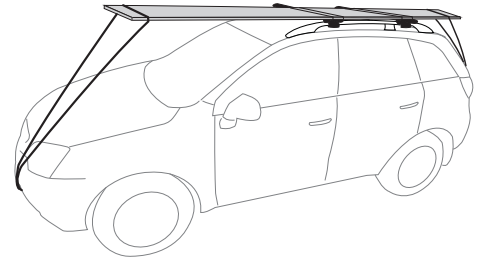
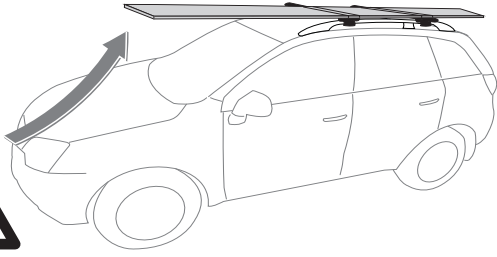

The handling characteristics of the vehicle changes when you transport a load on the roof. For safety reasons we recommend you exercise extreme care when transporting wind-resistant loads. Special consideration must be taken into account when cornering and braking.

Although the system is tested and approved to AS1235-2000 / ISO 11154, off-road conditions can be much more rigorous. Extreme care must be taken in off road conditions

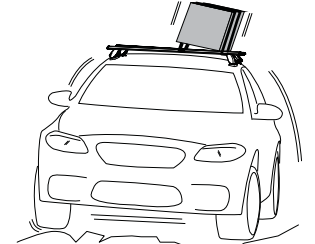
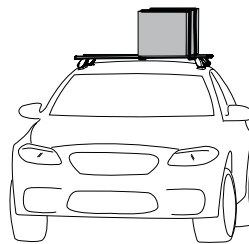

**System Weight: 25.5kg - 33kg**

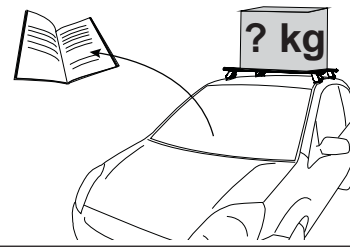
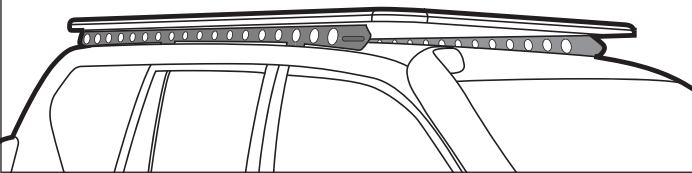

**Static Load Rating:** refer to front page



**Ensure Ladder is well supported on the ground to help support tent. Take extreme caution when climbing heights above 1.2m/4ft.**

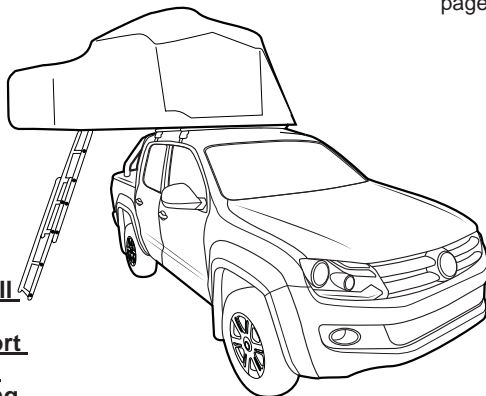

**Paddle/ Surfboards should be fixed to the front of the vehicle.**

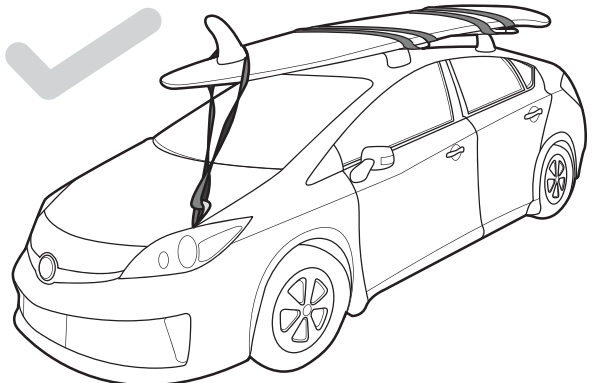

# Toyota Tacoma Backbone - RTTB1

## Parts List

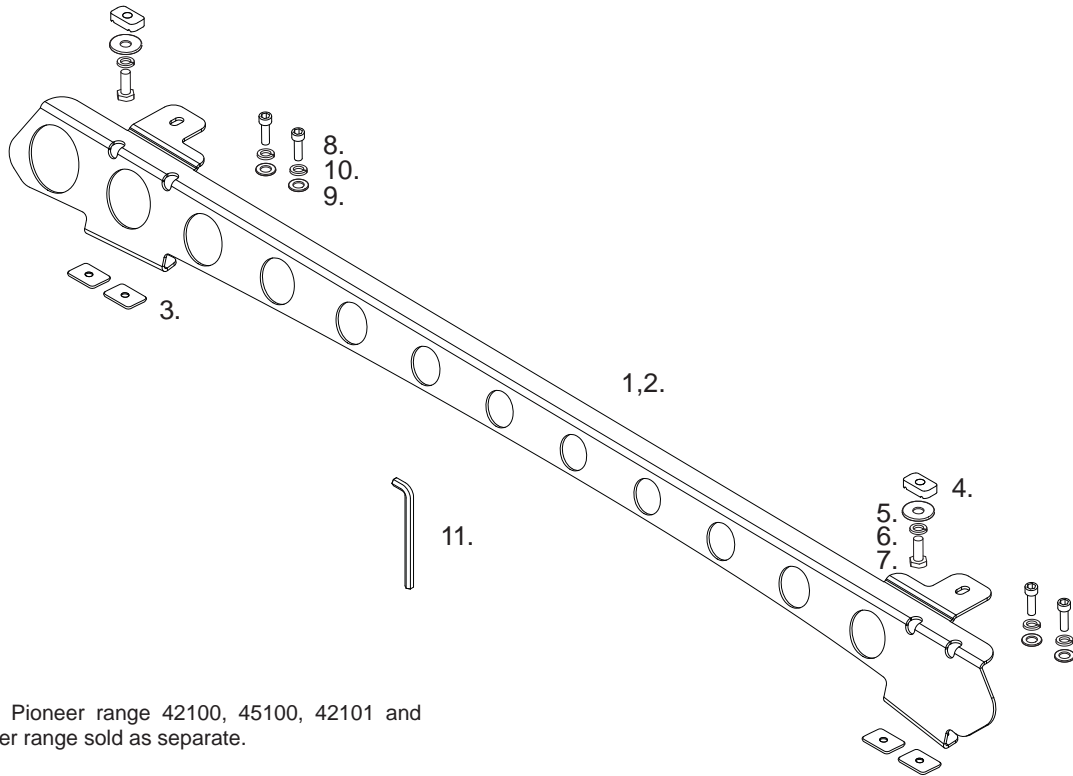

For use with Pioneer range 42100, 45100, 42101 and 45101. Pioneer range sold as separate.

Item	RTL B1 Kit	Qty	Part No.
1	Tacoma LH Backbone	1	CA1501
2	Tacoma RH Backbone	1	CA1502
3	Butyl Patch 20x20mm 5mm Hole	8	CA1266
4	M8 Channel Nut	4	N003
5	M8x19x2.5 Flat Washer	4	W043
6	M8 Spring Washer	4	W019
7	M8x20 Hex Setscrew	4	B020-BLK
8	M6x20 Socket Head Screw	8	B163
9	M6 x 18mm Flat Washer	8	W031
10	M6 Spring Washer	8	W019
11	Short 6mm Allen Key	1	H050
12	Instructions	1	R989

### Tools Required:

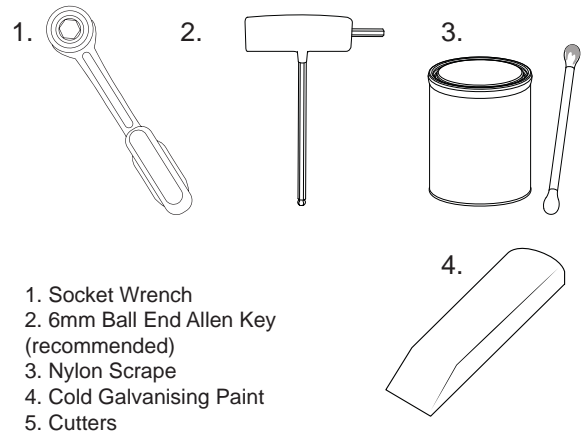

1. Socket Wrench
2. 6mm Ball End Allen Key (recommended)
3. Nylon Scrape
4. Cold Galvanising Paint
5. Cutters

- 1 Starting at the front of the vehicle, carefully lift out the Ditch Mould. Be sure Ditch is clean.

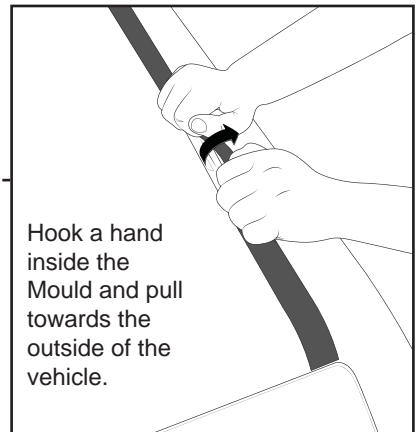
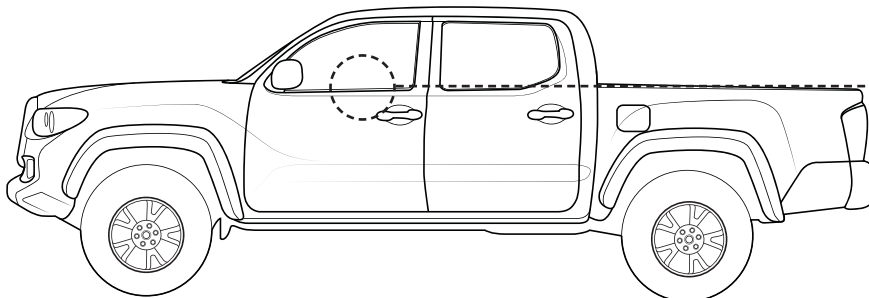

Hook a hand inside the Mould and pull towards the outside of the vehicle.

# Toyota Tacoma Backbone - RTTB1

- 2** Locate the Painted Butyl Patches within the Ditch. With a Nylon Scrape, carefully remove the Patches both front and rear.

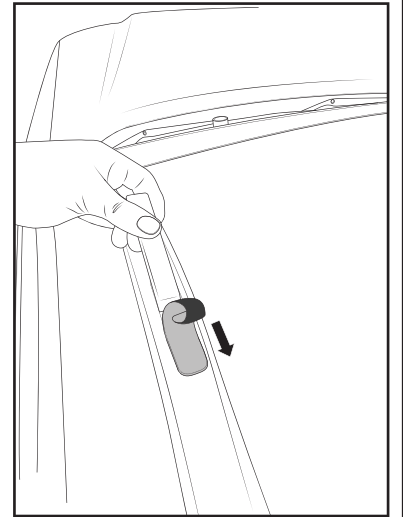
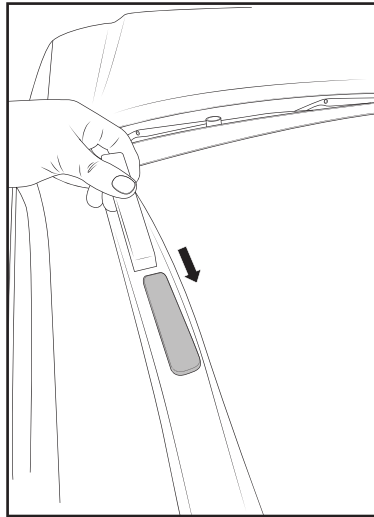
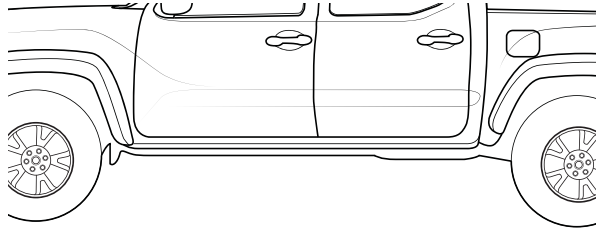

- 3** Use Cold Galvanising Paint to cover the newly exposed area. It is imperative that all body work is covered.

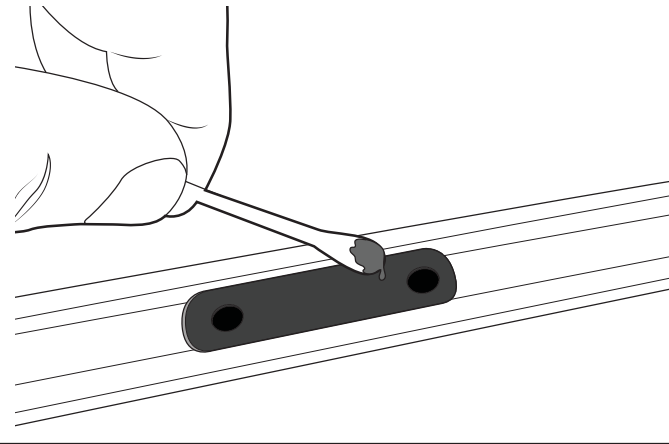

- 4** Test exposed threads with M6 Screws. Remove any material causing binding.

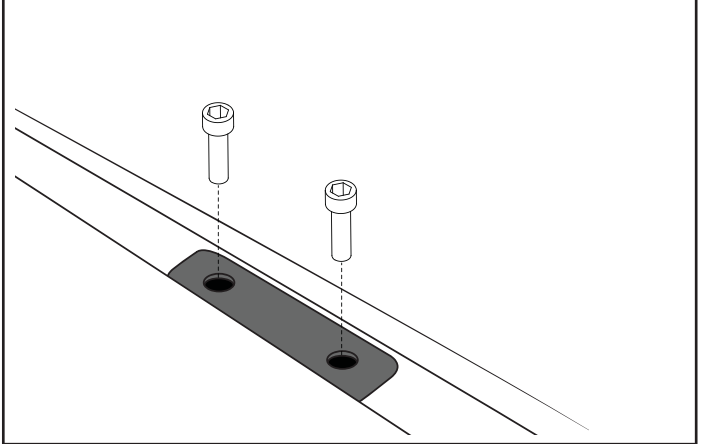

- 5** Remove one side of protective tape from the Butyl Patches provided. Place carefully over the exposed threads. Remove the top layer of protective tape from the installed Patches.

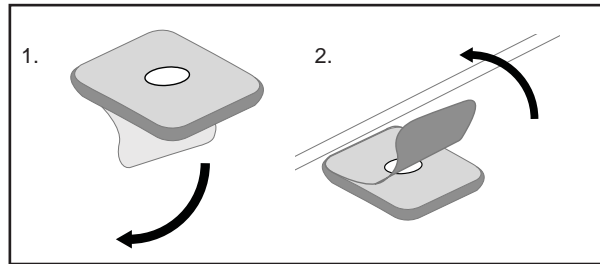
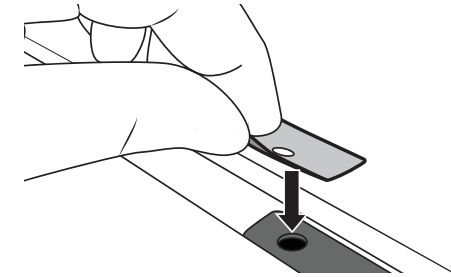

- 6** Place one side of the Backbone onto the roof of the vehicle. Line up the mounting points of the bracket to the those exposed on the roof in the previous steps.

Front View:

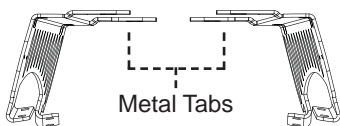

Metal Tabs

Metal Tabs face in toward the vehicle.

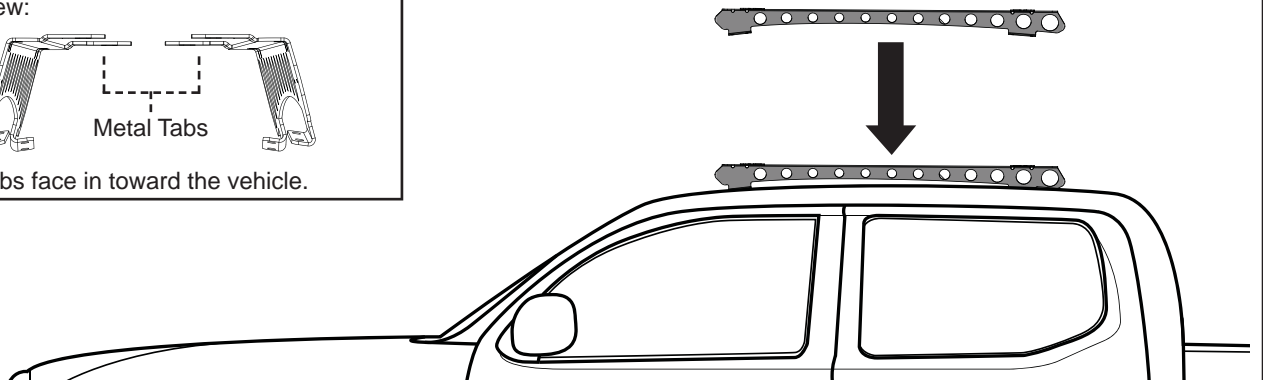

# Toyota Tacoma Backbone - RTTB1

- 7** Using the M6 Socket Screws, M6 Spring and Flat Washers, place the hardware into mounting holes of rails. Make sure hardware and holes align with roof mounts before proceeding to Step 8.

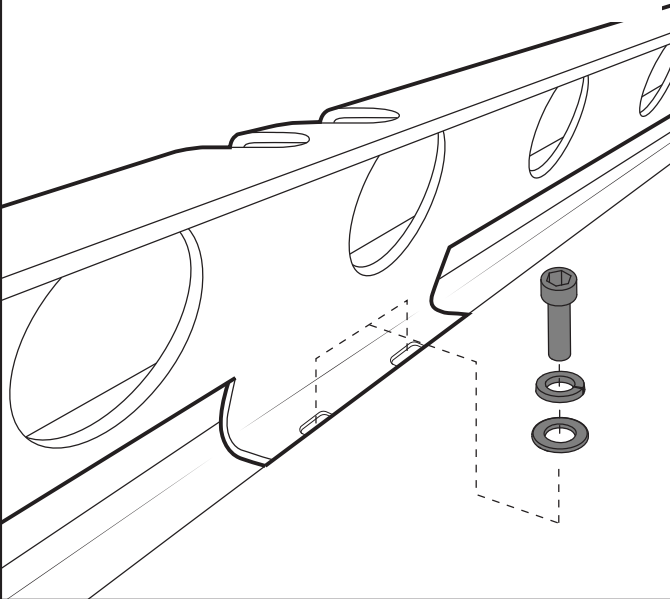

- 8** Start carefully securing the Backbone by tightening the M6 socket hardware into the roof fixed mount points with a 6mm Ball End Allen Key.

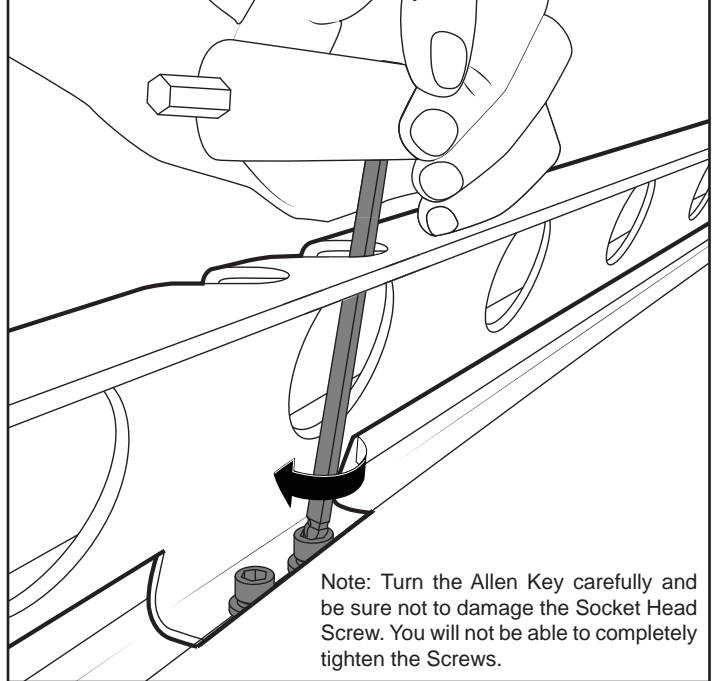

- 9** After all bolts have been tightened as much as possible with the Ball End Allen Key - tighten completely using the Small 6mm Allen Key that is provided with the kit.

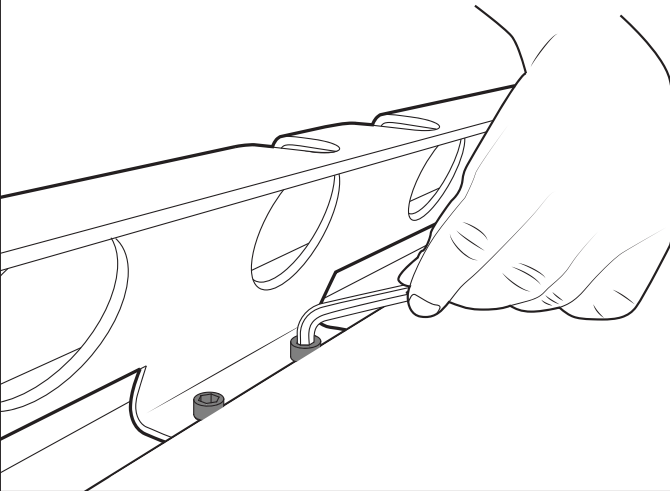

- 10** Repeat steps 2-10 for securing opposite side Backbone rail.

Ensure both Backbones are securely positioned on the car. Check each bolt before proceeding to attaching the Pioneer tray to the Backbone Rails.

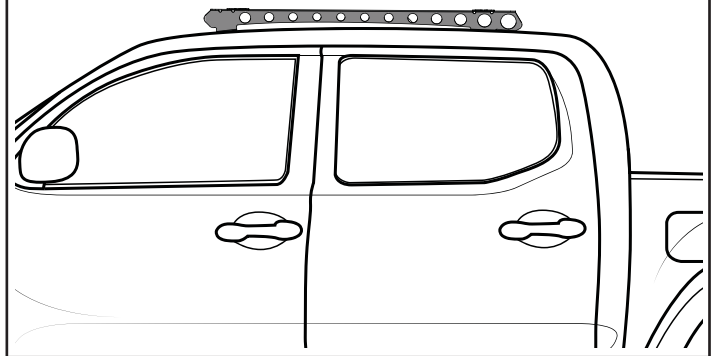

- 11** Assemble M8 Hardware as pictured below. Complete this for the four tabs on top of the backbone rails (two each rail).

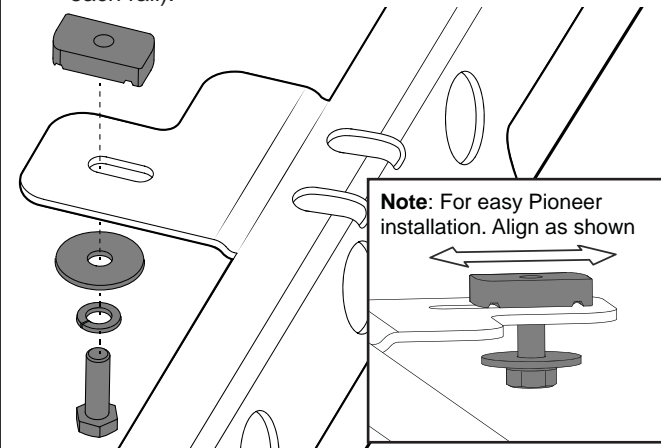

- 12** Install Pioneer Underbars with slots indicated (42100, 45100, 42101 or 45101).

**REAR:** 125mm from Rear (using slots)

**FRONT:** 100mm from Front (drill)

The rear slot will have to be drilled with an 8.5mm drill bit. For detailed underbar installation instructions, refer to Pioneer fitting instructions.

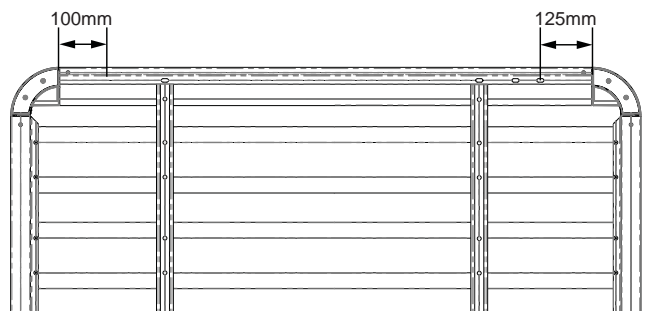

# Toyota Tacoma Backbone - RTTB1

- 13** After Underbars have been correctly fitted, place the Pioneer tray on top of the Backbone. Align the Underbars with the top tabs and ensure the M8 hardware fits into underbar channel.

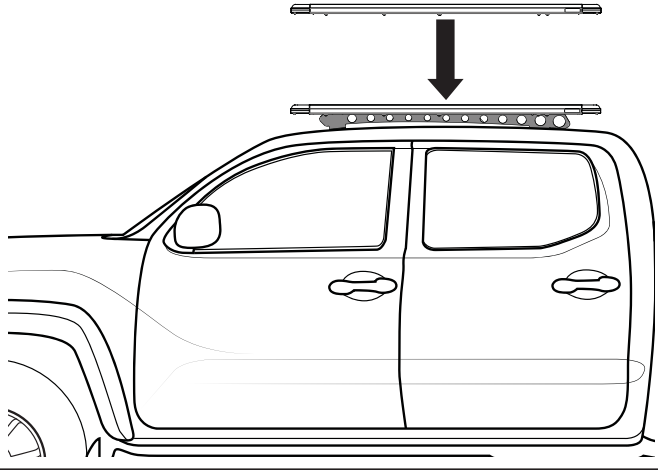

- 14** Once Pioneer Underbars have been aligned properly, tighten all M8 hardware using 13mm (1/2") Socket Wrench or 13mm (1/2") Spanner. Ensure channel nut has rotated within Pioneer underbar and is fixing Pioneer securely.

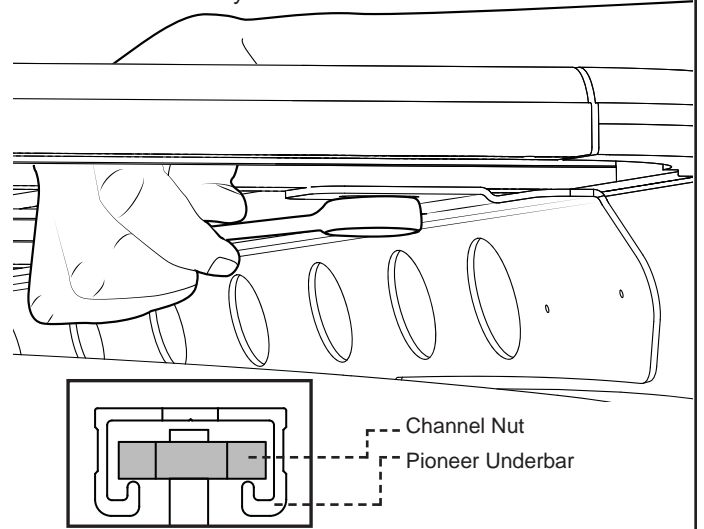

- 15** The Ditch Rubber can cut and refit on either side of the Backbone.

