



RHINO-RACK

RTS547 Toyota Tacoma

Important: Please read these instructions carefully prior to installation. Please refer to your fitting instruction to ensure that the Canopy Rack System is installed in the correct location. Check the contents of kit before commencing fitment and report any discrepancies. Place these instructions in the vehicle's glove box after installation is complete.

Fit time: 1 Hour.

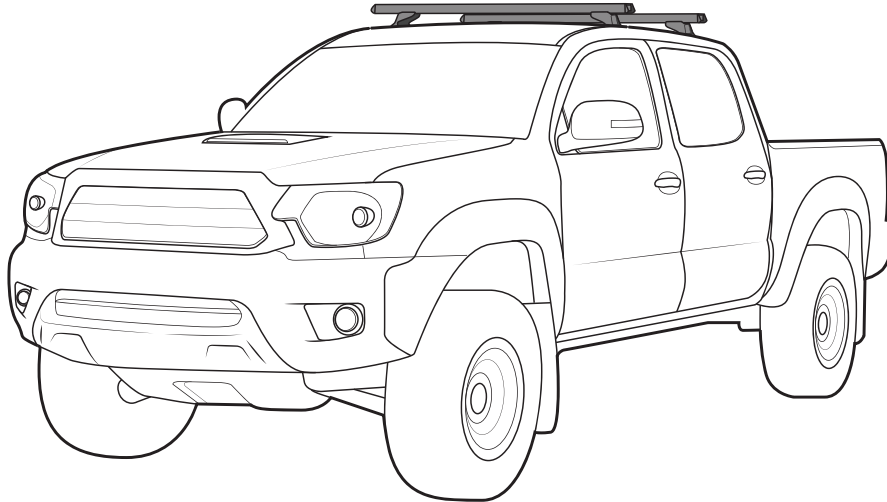

Important Information

Maximum carrying capacity:

On Road Cargo Allowance	Unsealed Road Cargo Allowance	Roof Allowance	Rack Weight
95kg / 209lb	66kg / 145lb	100kg / 220lb	5kg / 11lb

Roof Allowance: Total permissible weight attached to the roof of the car. This is inclusive of the weight of the roof rack system

Cargo Allowance: Total permissible weight allowed on top, and attached to roof racks whilst the vehicle is in motion. Please refer to your vehicle manufacturers handbook for maximum carrying capacity. Always use the lower of the two figures. Load must be evenly distributed over the entire Pioneer. Weight of roof rack accessories is to be included in cargo allowance.

Torque settings

Unless stated otherwise in these instructions, all fasteners should be set to the following torque settings - M6: 4-5Nm (3-4lbs/ft), M8: 8-10Nm (6-7.5lbs/ft) and M10: 16-18Nm (12-13lbs/ft).

Warning:

- Check Part No. and/ or Kit is correct for use with your vehicle
- Do not attempt to fit the rack system to your vehicle unless you fully understand these fitting instructions. Please direct any questions regarding fitting to the dealer from where the roof racks were purchased.
- **Use only non-stretch fastening ropes or straps.**
- The handling characteristics of the vehicle changes when you transport a load on the roof. For safety reasons we recommend you exercise extreme care when transporting wind-resistant loads. Special consideration must be taken into account when cornering and braking.
- Although the system is tested and approved to AS1235-2000 / ISO 11154, off-road conditions can be much more rigorous. Extreme care must be taken in off road conditions



RTS547 Toyota Tacoma

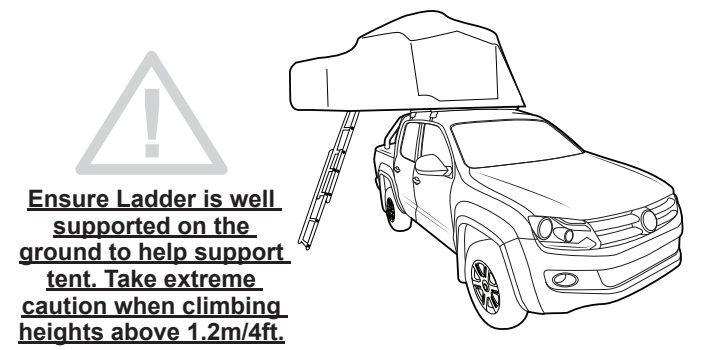
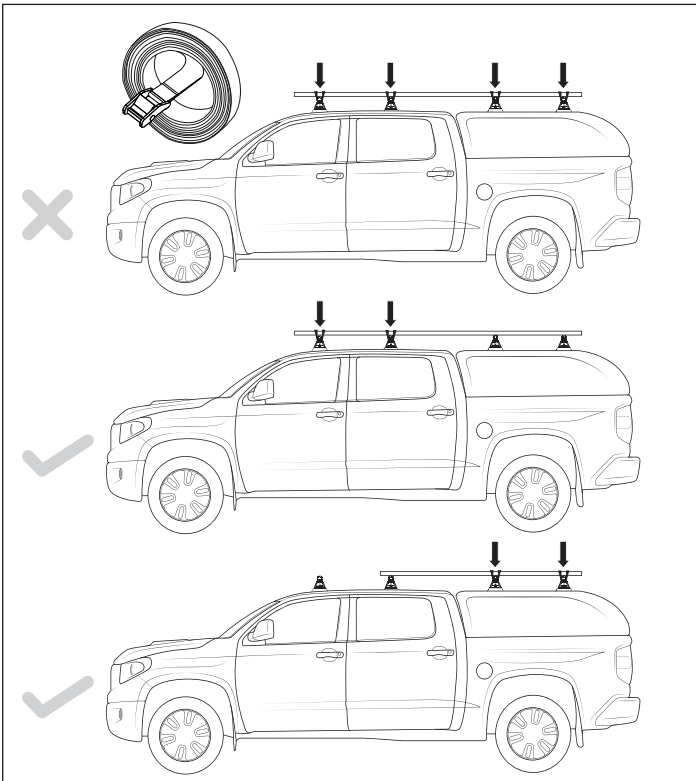
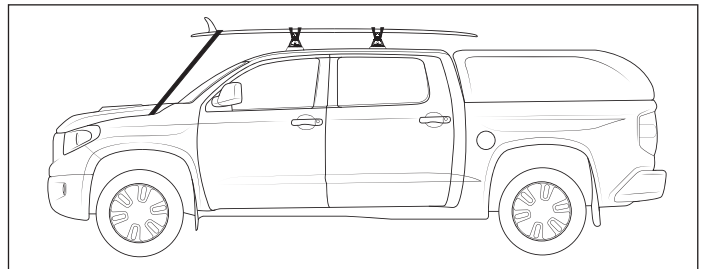
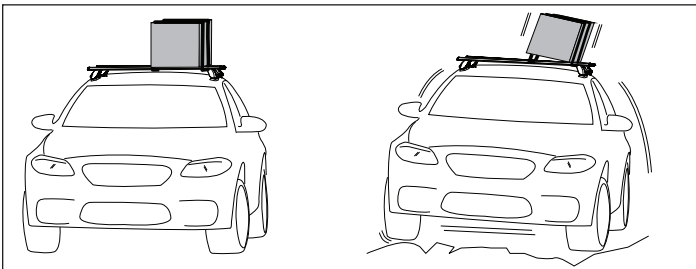
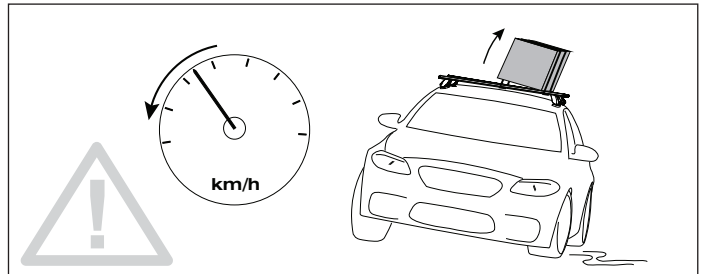
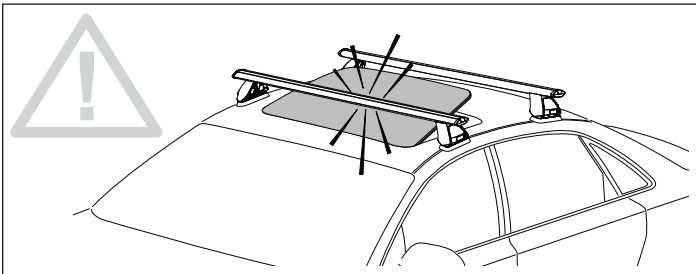
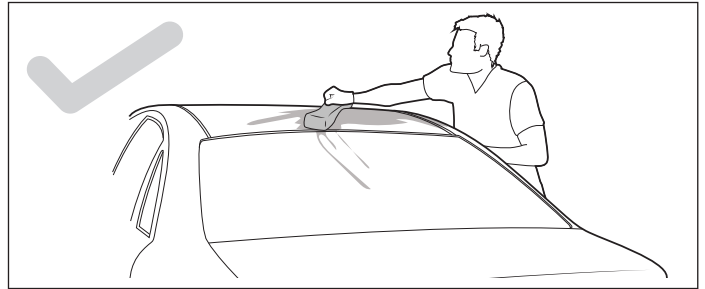
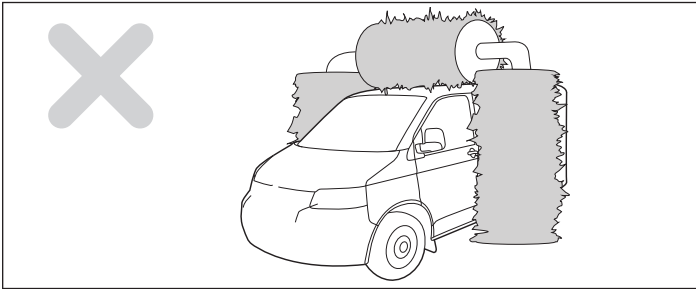
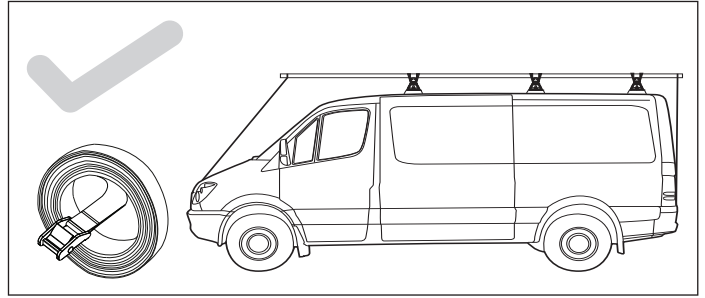
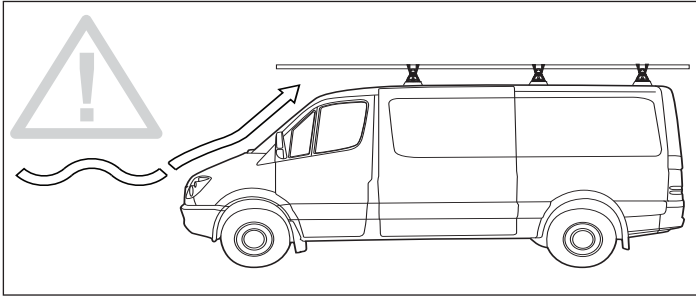



RTS547 Toyota Tacoma

Parts List

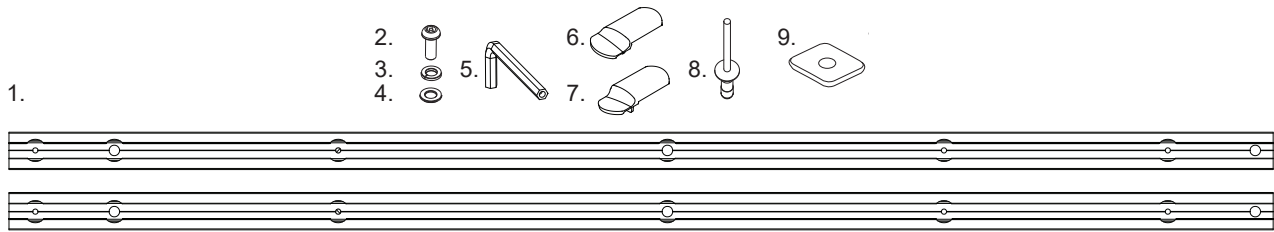

Item	RTS543 Kit	Qty	Part No.
1	Tacoma Track Left and Right	2	A788
2	M6 x 20mm Button Screw	6	B062
3	M6 Spring Washer	6	W004
4	M6 x 16mm Flat Washer	6	W031
5	5mm Allen Key	1	H021

6	End Cap FR, RL	2	M214
7	End Cap FL, RR	2	M215
8	Stavex Rivet BS 11 4.8mm	8	H060
9	Butyl Patch 4.5mm Hole	14	CA1397
10	Instructions	1	R1037

Tools Required:

1. Measuring Tape
2. Drill
3. 5mm Drill Bit
4. Drill Stop
5. Cold Galvanising Paint
6. Cotton Buds
7. Screwdriver
8. Clean Cloth
9. Marker
10. Vacuum Cleaner
11. File
12. Cutters

Note:

Crossbar and Leg Kits are sold as separate.

Preparing Vehicle

- 1 Move to the roof of the vehicle. Carefully pry out the Ditch Mould with a finger near the windshield. Lift the Mould out, releasing it from the retention clip in the front.

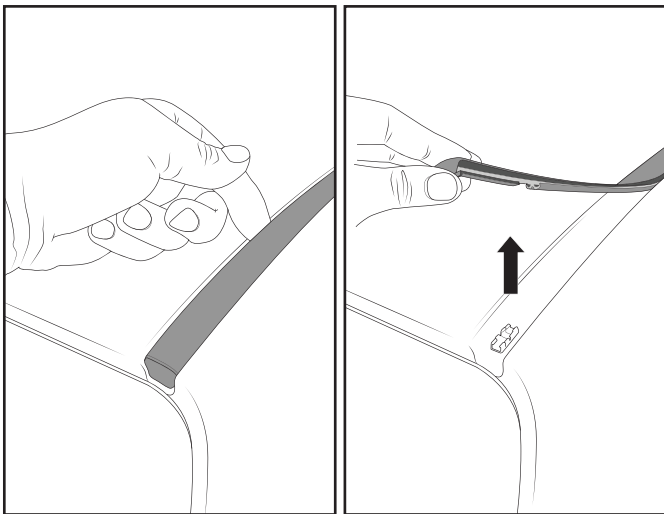

- 2 Release the Ditch Mould at the rear of the vehicle partially from the retention clip. Do not pull the Ditch Mould out past the Tooling Mark.

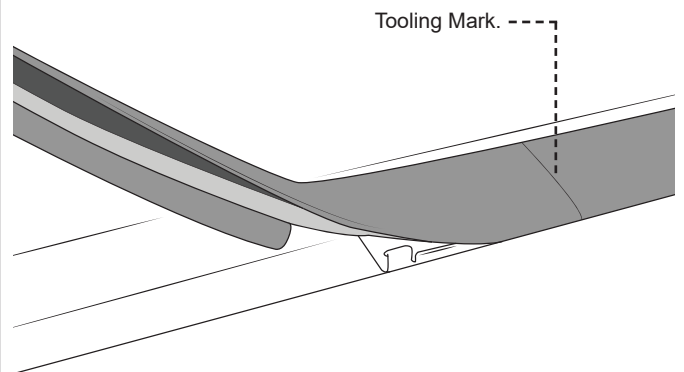

- 2 Locate the two Factory Seals from the front, middle and rear. Carefully remove the rear of the two seals as shown below.

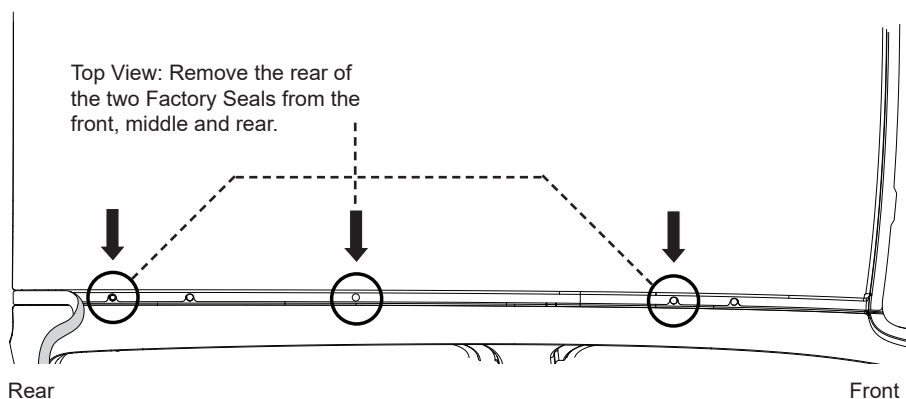

Peel the Seals away from the roof. A screwdriver can be used to pierce the Seal first. Careful not to mark the paintwork.

File the overlapping roof panel if shape of hole isn't round (due to varying build tolerances)

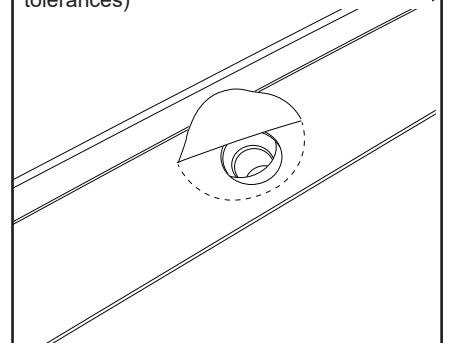



RTS547 Toyota Tacoma

3 Place the Tracks into the Roof Ditch. Be sure to use correct orientation.

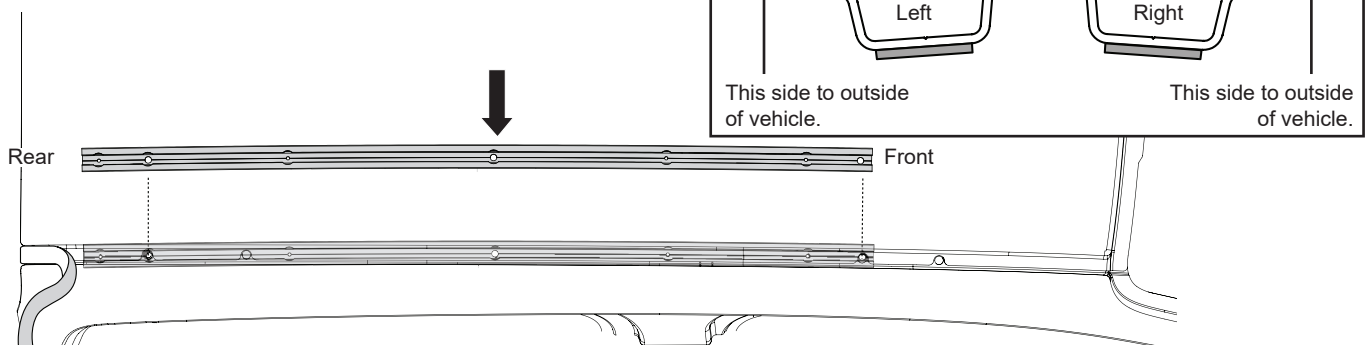

4 Place an M6 Button Screw with an M6 Spring and Flat Washer in the positions shown, front, middle and rear. Finger tighten at this stage.

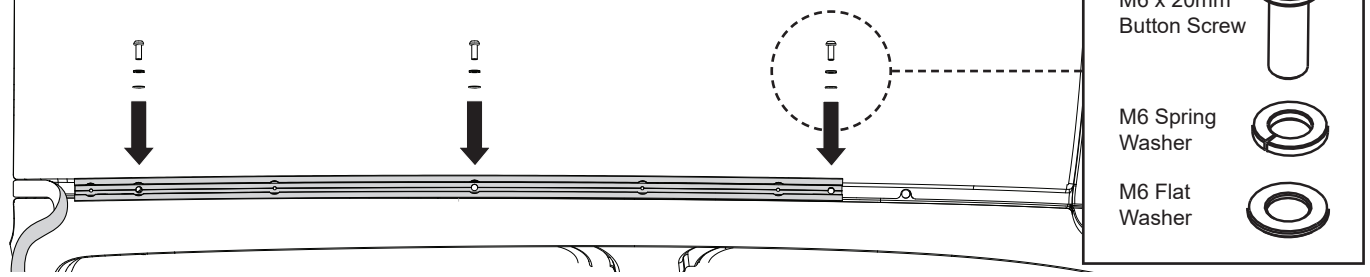

5 Using a 5mm (3/16") Drill Bit, spot mark each of the Rivet Holes in the Track onto the roof. Do not drill completely through the roof skin.

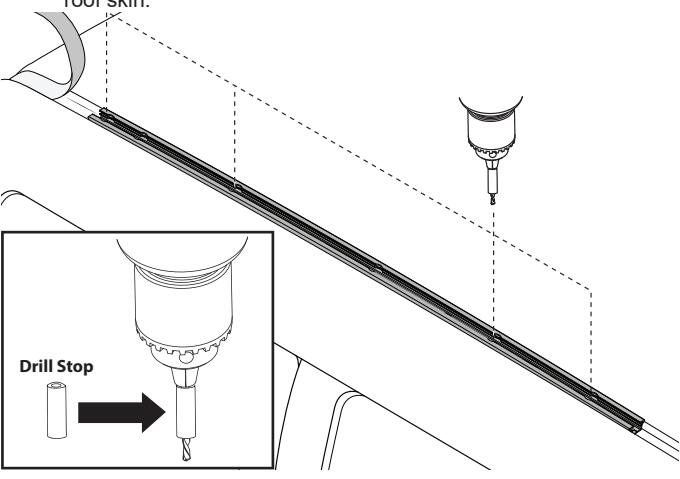

6 Remove the Track from the Roof. Drill out all spot marks with a 5mm (3/16") Drill Bit. Use a Drill Stop set to 5mm (3/16").

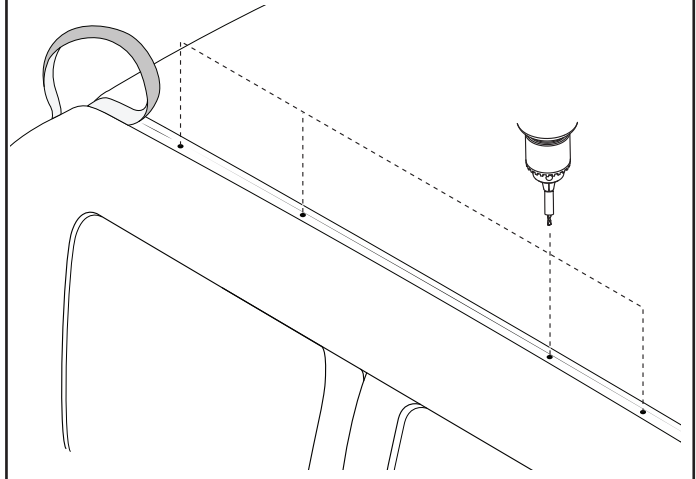

7 Vacuum any swarf from the roof.

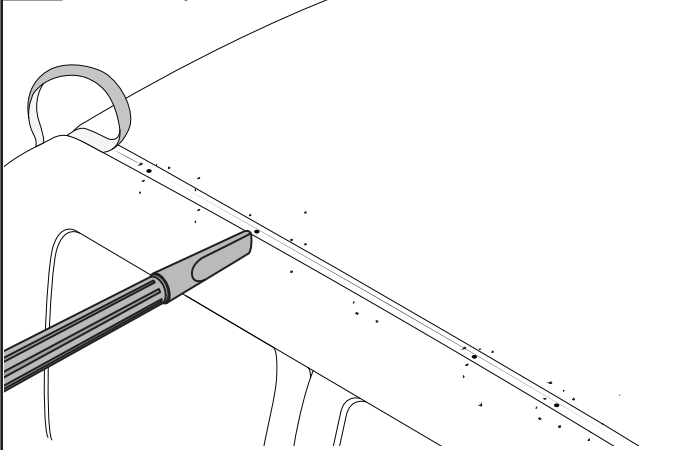

8 Use Cold Galvanising Paint on all holes drilled and any exposed body work.

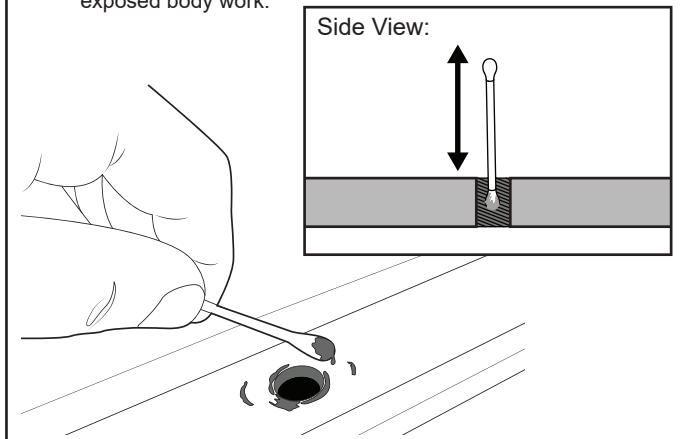



RTS547 Toyota Tacoma

9 Peel off the one side of backing tape on the Butyl Patches provided. Place these carefully over all holes in the ditch. Remove the top layer of backing tape as shown.

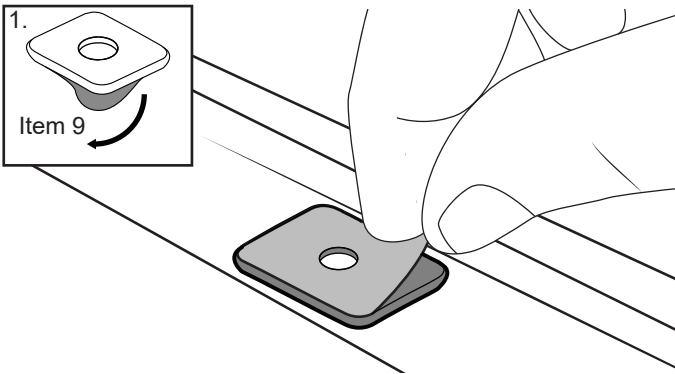

10 Remove backing tape from the Tracks.

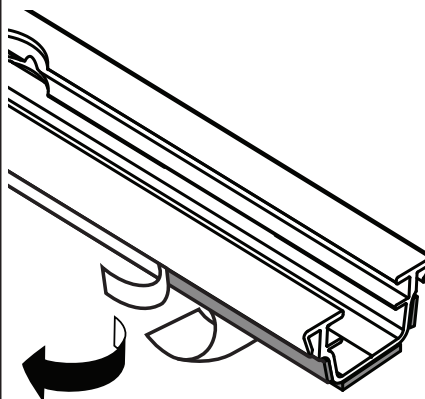

11 Place an M6 Button Screw with an M6 Spring and Flat Washer in the positions shown, front, middle and rear. Tighten with the Allen Key supplied.

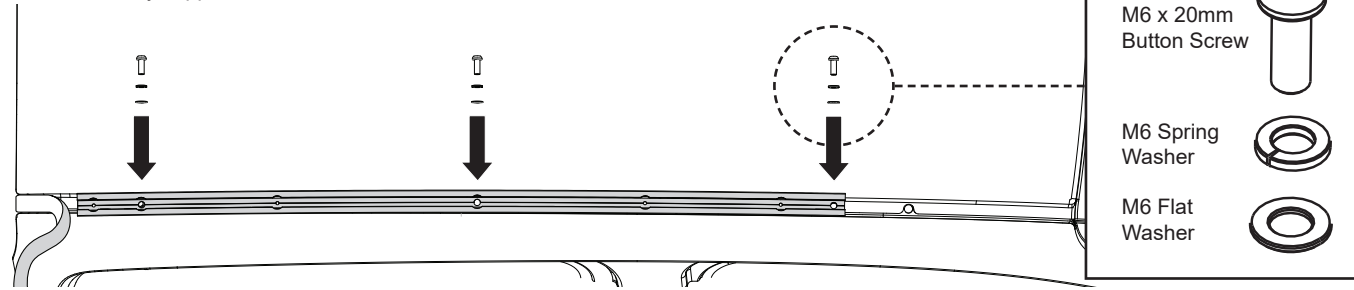

12 Rivet the Track in place. Be sure Rivets are seated correctly before depressing the Tool.

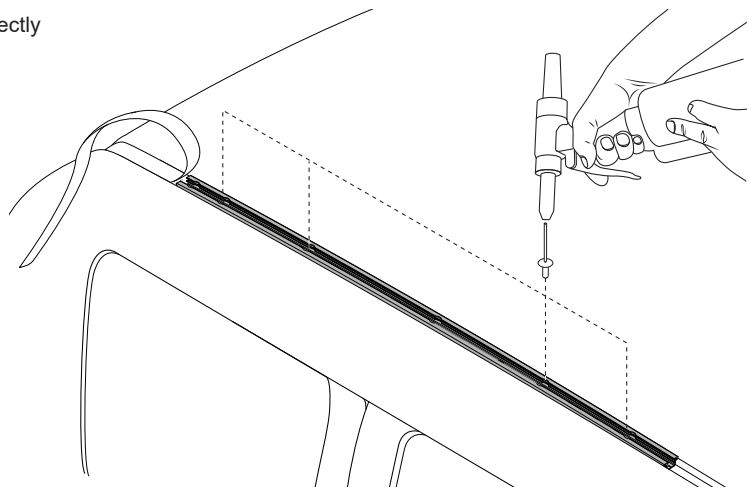

13 Measure and cut the Rubber at the front and rear of the Track 5mm (3/16") out as shown.

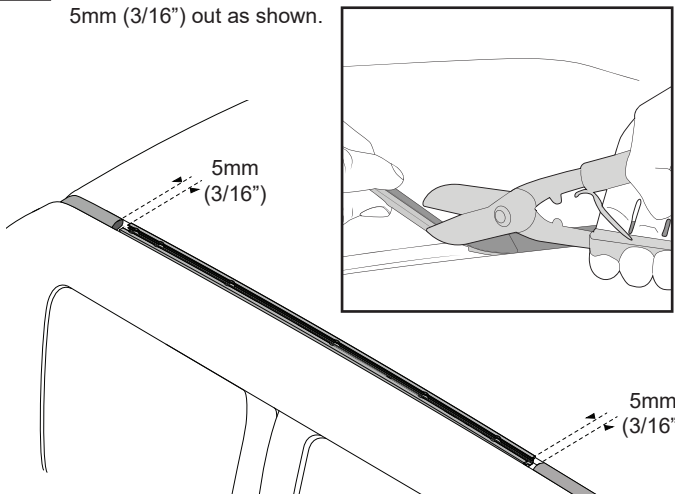

14 Insert the End Caps front and rear of the Track.

