



# RHINO-RACK

## Toyota Rav4 Backbone - RTRB1

**Important:**

1. Check the Rhino-Rack website to ensure you have the latest issue of these instructions.
2. Please refer to your fitting instruction to ensure that the roof racks are installed in the correct locations.
3. Check the contents of kit before commencing fitment and report any discrepancies.
4. Place these instructions in the vehicle's glove box after installation is complete.
5. These instructions must be followed for warranty to be upheld.

**Fit Time:** 1 hour

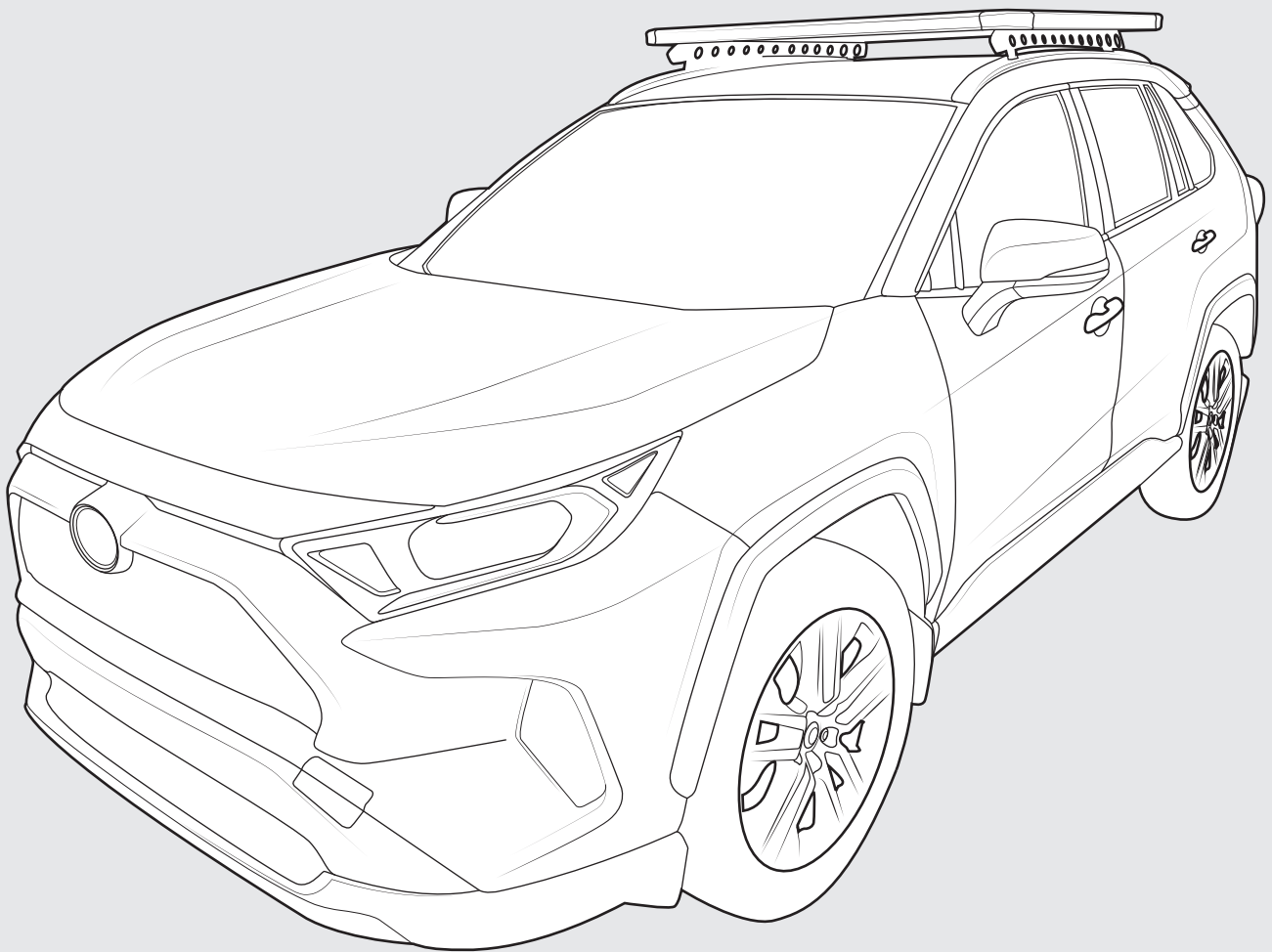

# RTRB1 Backbone Instructions

---

## Carrying Capacity

### Max system load capacity

Check your vehicle owners hand book for vehicle maximum carrying capacity. Please ensure you use the vehicle manufacturers maximum roof allowance if it is lower than the figure listed in this instruction.

Load must be evenly distributed over the system.

ON ROAD CARGO ALLOWANCE (OR)	OFF ROAD CARGO ALLOWANCE (OFR)	VEHICLE ROOF LOAD LIMIT (VLL)	SYSTEM WEIGHT (SW)
$(OR) = (VLL) - (SW)$	$(OFR) = \frac{(OR)}{1.5}$	XXkg / XXlb (CHECK VEHICLE OWNERS HANDBOOK FOR SPECIFIC FIGURE).	4kg/8.8lbs + Platform Weight

**Off Road:** Any driven path taken that does not contain a surface protection layer (tar/bitumen).

**Vehicle Load Limit:** Total permissible weight attached to the roof of the car. This is inclusive of the weight of the roof rack system.

**System Load Limit:** Total permissible weight allowed on top, and attached to roof racks whilst the vehicle is in motion.

### Torque Settings

Unless stated otherwise in these instructions, all fasteners should be set to the following torque settings - M6: 4-5Nm (3-4lbs/ft), M8: 8-10Nm (6-7.5lbs/ft) and M10: 16-18Nm (12-13lbs/ft).

## Warning

---

- Check part number/ or kit is correct for use with your vehicle.
- Do not attempt to fit the rack system to your vehicle unless you fully understand these fitting instructions. Please direct any questions regarding fitting to the dealer from where the roof racks were purchased.
- Off-road conditions can be rigorous. Extreme care must be taken in off road conditions.
- Roof racks must be removed when vehicle is put through an automatic car wash.
- With utility vehicles, the cabin and the canopy move independently. Roofracks and vehicle can be damaged if the item transported is rigidly fixed at points on both the cabin and canopy. Instead, rigidly fix to either the cabin roofracks or the canopy roofracks.
- Always ensure you fasten your load securely.
- Use only non-stretch fastening ropes or straps to attach cargo to your load.

## In service maintenance checks

---

- All bolted connections should be checked after driving a short distance when you first install your roof racks.
- All bolted connections should be checked again at regular intervals ( every 1000k (621mi) is recommended, depending on road conditions, usage, loads and distances travelled).

## Note for Dealers and Fitters

---

It is your responsibility to ensure these fitting instructions are given to the end user or client. These instructions remain the property of Rhino-Rack Australia Pty. Ltd. and may not be used or changed for any other purpose than intended.

# RTRB1 Backbone Instructions

## Parts list

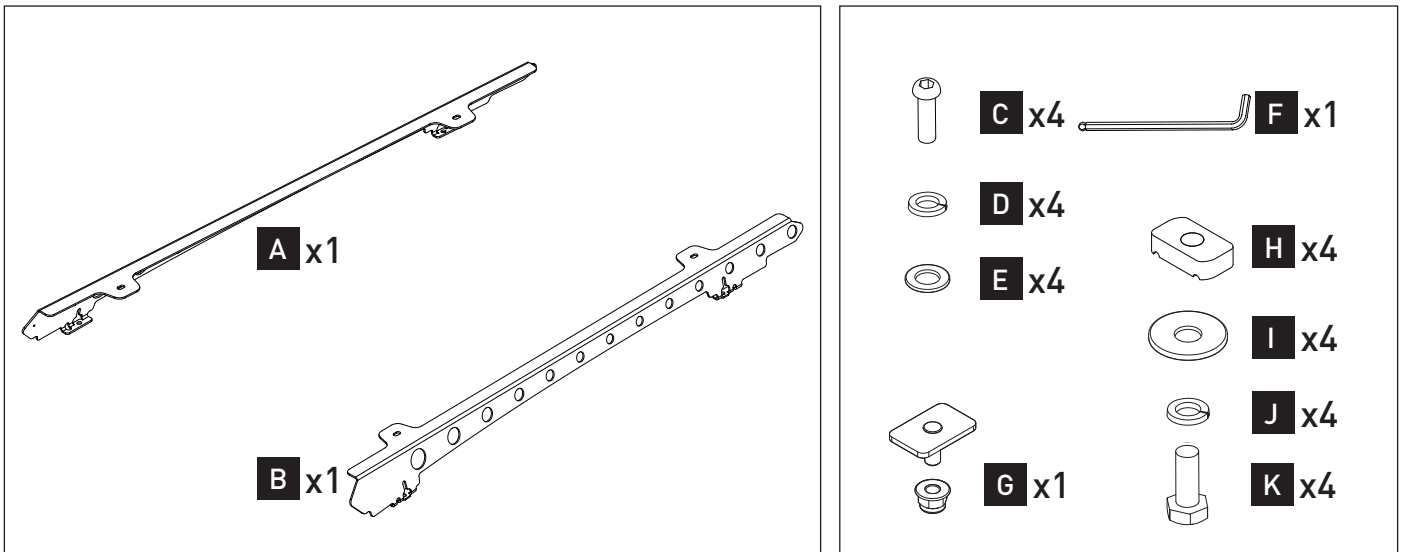

Item	Description	Qty
A	XA50 Rav4 Backbone LH	1
B	XA50 Rav4 Backbone RH	1
C	M8 Button Head Cap Screw	4
D	M8 Spring Washer	4
E	M8 Flat Washer	4
F	6mm Allen Key	1
G	NG Bolt Kit	1
H	M8 Channel Nut Black	4
I	M8 Flat Washer Black	4
J	M8 Spring Washer Black	4
K	M8 Hex Setscrew Black	4
L	Instruction	1

### Tools Required -Herramientas necesarias:

T1 - Flat blade screwdriver. T3 - 10mm socket wrench.

T2 - Masking tape.

### Note:

**Item G required with use of 52xxx series Pioneer.**

Item H, I, J & K required only with use of 4xxxx series Pioneers - refer to step 9, pg 7.

# RTRB1 Backbone Instructions

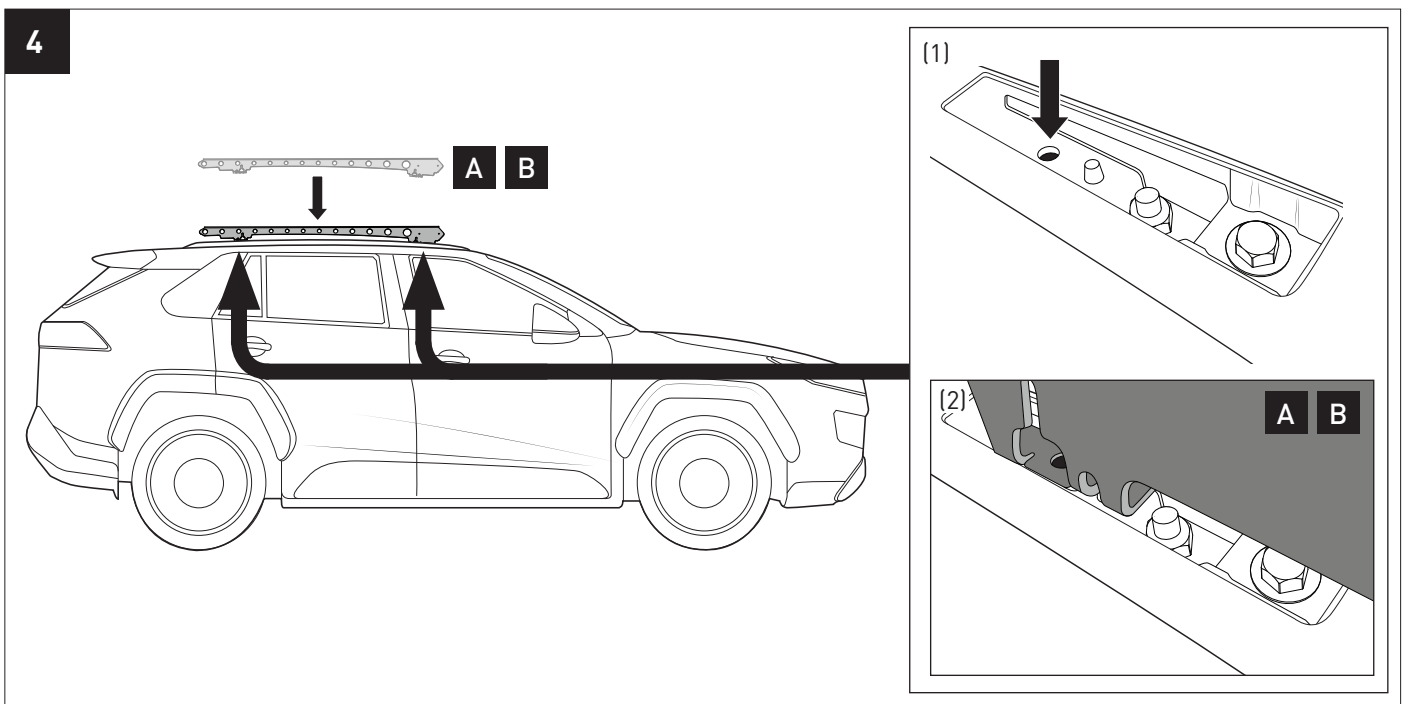
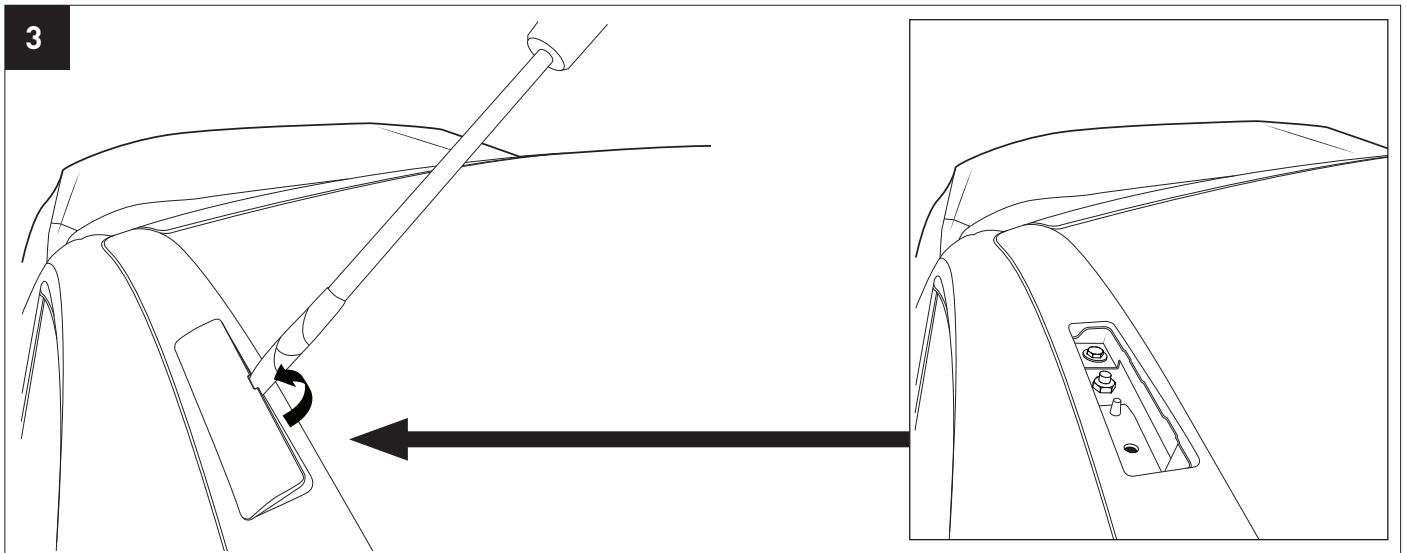
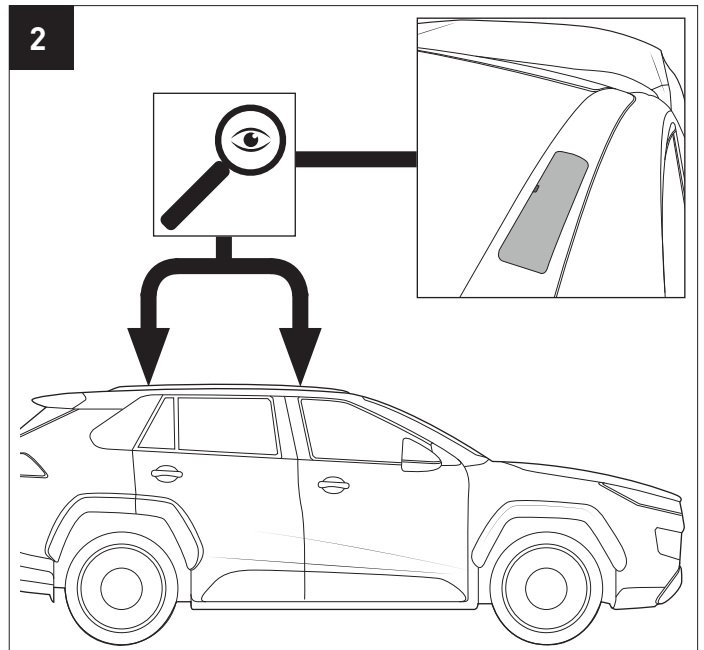
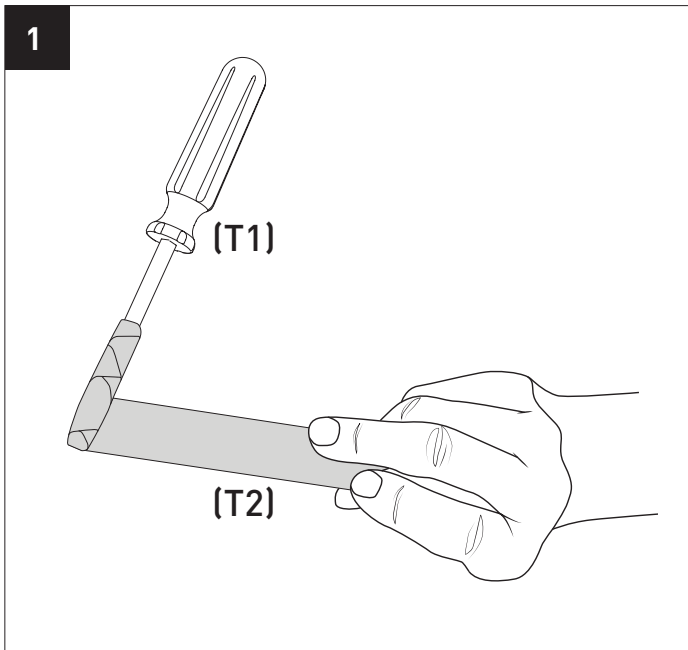



# RTRB1 Backbone Instructions

