



# RHINO-RACK

Aerodynamic & Heavy Duty Roof Rack Systems

## RLZ02 - Rear Cross Bar, Ford Transit Connect.

**Important:** Please read these instructions carefully prior to installation.  
Please refer to your fitting instruction to ensure that the roof racks are installed in the correct locations.  
Check the contents of kit before commencing fitment and report any discrepancies.  
Place these instructions in the vehicle's glove box after installation is complete.

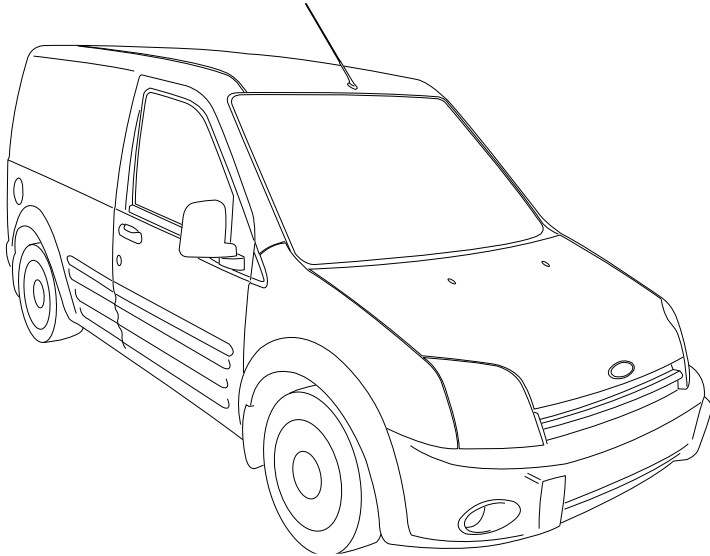

Wash vehicle roof prior to installation.  
Please read through instructions  
before fitting the racks to your vehicle.

### Important Information

**Maximum carrying capacity:** 100kg (220lbs), evenly distributed over the cross bars.

**Recommendations:**

It is essential that all bolt connections be checked after driving a short distance when you first install your cross bars. Bolt connections should be checked again at regular intervals (probably once a week is enough, depending on road conditions, usage, loads and distances travelled). You should also check the cross bars each time they are re-fitted.

Make sure to fasten your load securely. Please ensure that all loads are evenly distributed and that the centre of gravity is kept as low as possible.

**Use only non-stretch fastening ropes or straps.**

The handling characteristics of the vehicle changes when you transport a load on the roof. For safety reasons, we recommend you exercise extreme care when transporting wind-resisting loads; Special consideration must be taken into account when cornering and braking.

**Please remove cross bars when putting vehicle through an automatic car wash.**

**Load Ratings:**

Maximum permissible load is 100kg (220lbs) per pair of cross bars. When cross bars are to be used in off-road conditions, please build a safety factor of 1.5 into this load limit. 67kg (147lbs) for off-road conditions. Although the cross bars are tested and approved to AS1235-2000. Road conditions can be much more rigorous. However, increasing the number of cross bars does not increase the vehicles maximum permissible roof loading.

**Note for Dealers and Fitters:**

It is your responsibility to ensure instructions are given to the end user or client.



# RLZ02 - Rear Cross Bar, Ford Transit Connect.

## Parts List

Item	Component Name	Qty	Part No.
1	End Cap	2	M002
2	M6 Hex Nut	4	N022
3	Leg Height Spacer	2	M016
4	5mm Rivet	8	H008
5	RLTP Leg	2	M057
6	Fixed Mount Pad Insert - RIGHT	2	M042
7	Fixed Mount Pad Insert - LEFT	2	M041
8	Fixed Mount Pad	2	M040
9	M6 x 45mm Security Screw	4	B091
10	PVC Foam Gasket	2	C135
11	M6 Spring Washer	4	W004
12	M6 x 12.5mm Flat Washer	4	W003
13	M10 Channel Nut	2	N024
14	M10 x 38mm Flat Washer	2	W022
15	M10 Shake Proof Washer	2	W021
16	M10 x 35mm Hex Bolt	2	B079
17	5mm Security Allen Key	1	SecKey-S
18	Fitting Instruction	1	RR-249

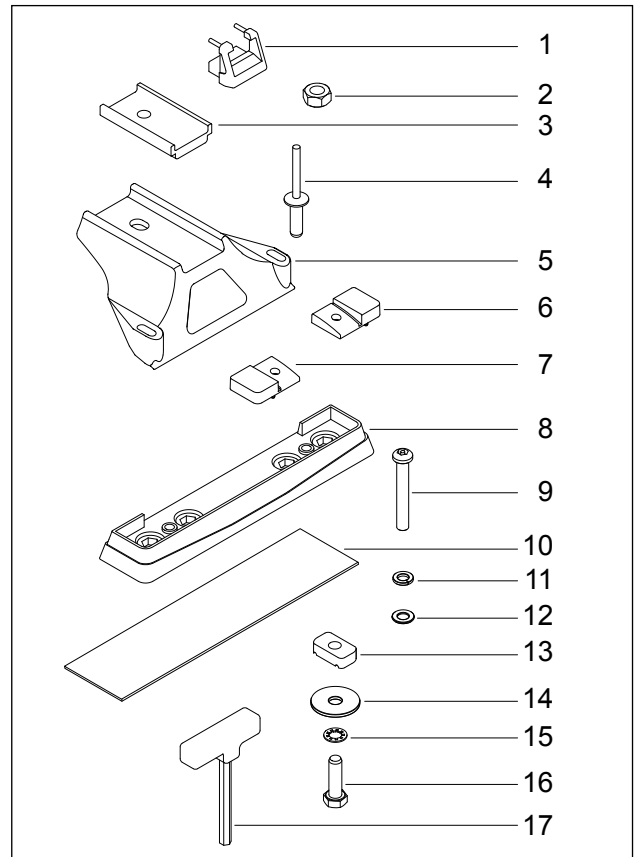

**Maximum carrying capacity: 100kg (220lbs) evenly distributed over cross bars.**

### Tools Required:

Security allen key,  
provided in kit.  
Utility knife.  
Small marking pen.  
Masking tape.  
Power or cordless drill.

5mm drill bit.  
Drill stop.  
Vacuum cleaner.  
Pneumatic or concertina  
rivet gun.  
Galvanising paint.

Silastic sealer.  
Measuring tape.  
16mm or 5/8" spanner.  
Rubber Mallet.  
Tape measure.  
Flat head screwdriver.

### Drill depth stop.

Round piece of wood  
or plastic of larger  
outer diameter than  
the hole being drilled.  
5-6 mm hole through  
centre.

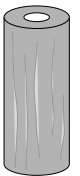

## 1 Fixed mount pads.

- Push the left and right fixed mount pad inserts in place on top of the pad.
- Locate two M6 hex nuts into the under side of each fixed mount pad. Peel the backing tape off and stick a PVC gasket to the underside of each pad.
- Trim excess PVC gasket from edge of each pad.

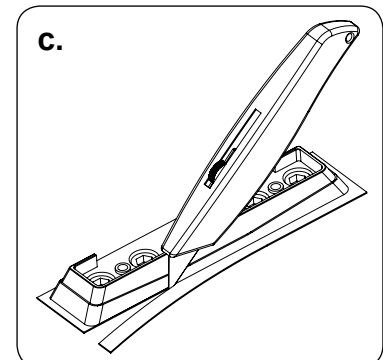
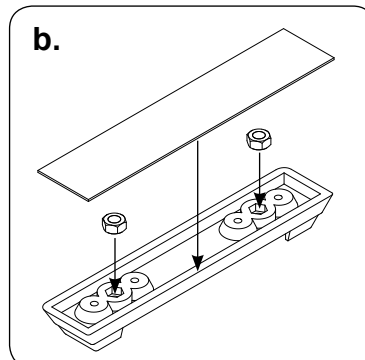
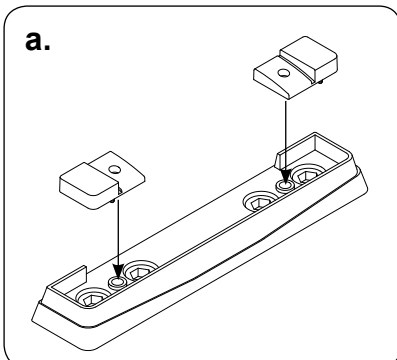



## RLZ02 - Rear Cross Bar, Ford Transit Connect.

**2**

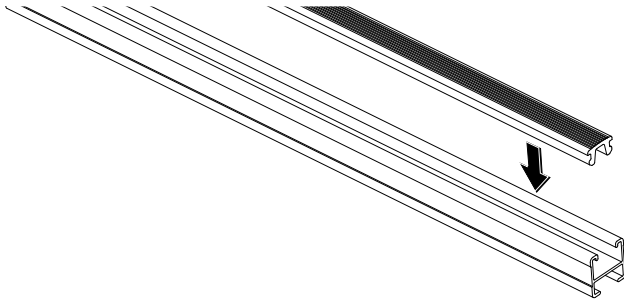

### Cross bar rubber.

Insert cross bar rubber buffer strip into the top of the cross bar.

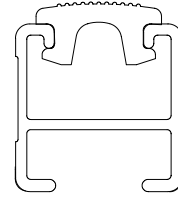

### **3** Attach components.

- a. Attach leg height spacer to RLTP leg using M10 hardware shown.
- b. Attach leg to fixed mount pad using M6 hardware as shown. Only tighten the leg enough to hold it securely in place. This is not final assembly.

**a.**

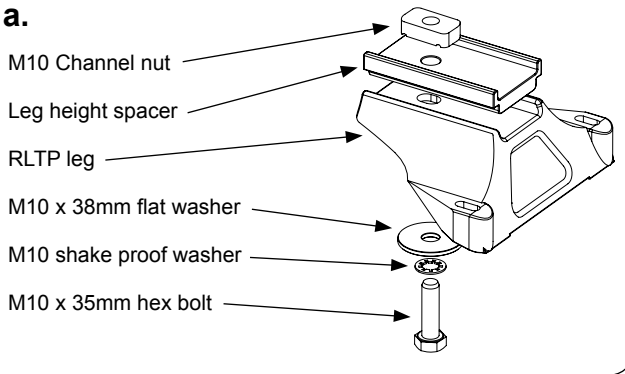

**b.**

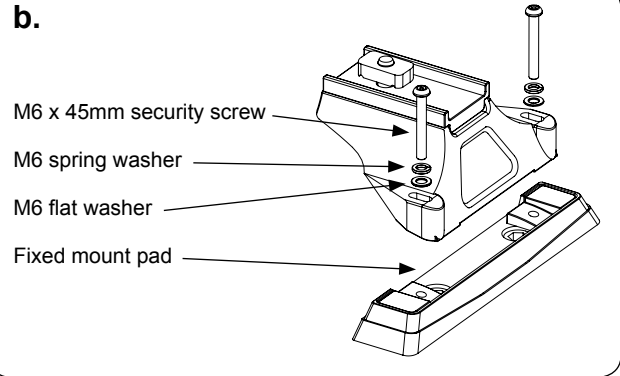

### **4** Attach cross bar.

Attach cross bar to legs. Make sure the channel nut is fully located across the bar. Tighten the M10 bolt well enough to hold the legs in place. This is not final assembly.



Channel nut must fully locate across the bar.

**5**

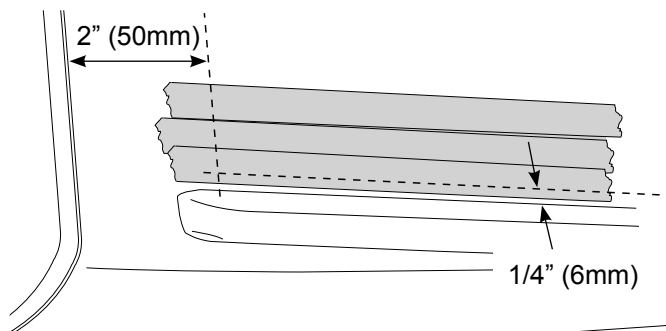

Right rear of vehicle

### Apply masking tape.

Stick masking tape to the rear section of the roof in front of the rear door jamb. This is where you will mark out the position of the fixed mount pad. Use enough tape to cover an area the size of the pad plus a bit extra. Sit the pad 2" in from rear of roof and 1/4" in from edge of outer most roof channel.



## RLZ02 - Rear Cross Bar, Ford Transit Connect.

6

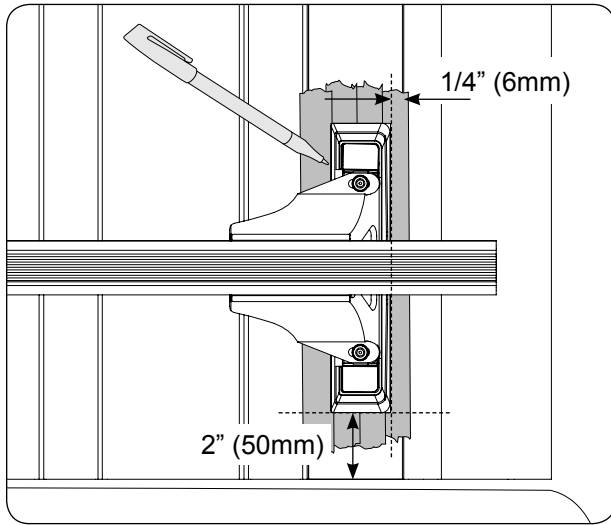

### Position fixed mount pads.

Sit the rack onto the roof. Position it square and evenly side to side so the pads are parallel across the vehicle.

Measure 2" from rear of body (not doors) forward. Measure 1/4" from inside edge of outer most roof channel so each pad is sitting on the flat section of the roof.

Use a thin marking pen to accurately draw around the base of each pad.

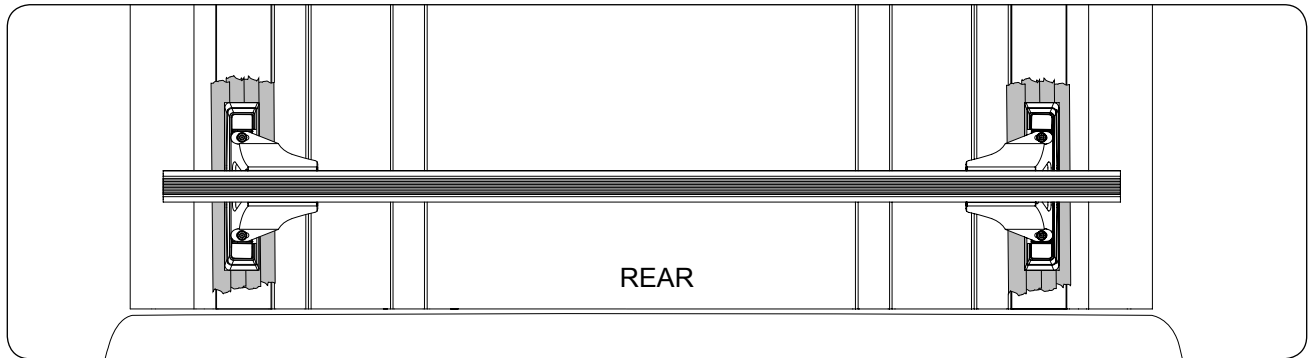

7

Remove pad inserts.

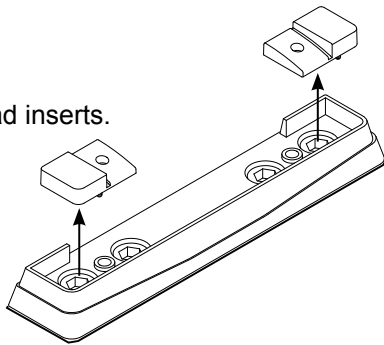

### Disassemble rack.

Disassemble the cross bar and legs. The fixed mount pads must be completely separated. Use a small flat head screw driver to pry off the left and right pad inserts.

8

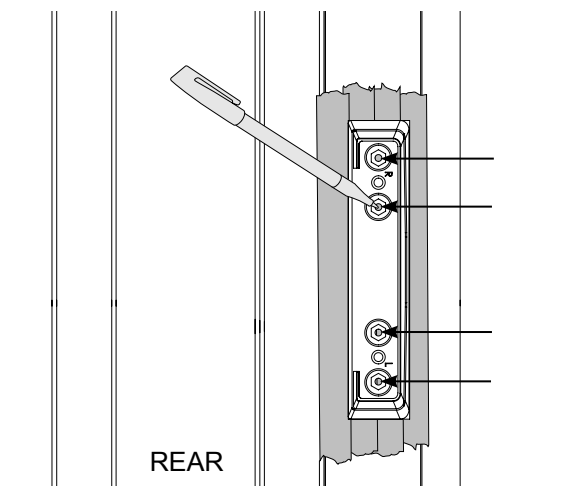

### Mark for drill holes.

Poke holes through the soft PVC. Position each pad back on its respective marked out perimeter. Mark a dot for the four positions on each pad to be drilled.

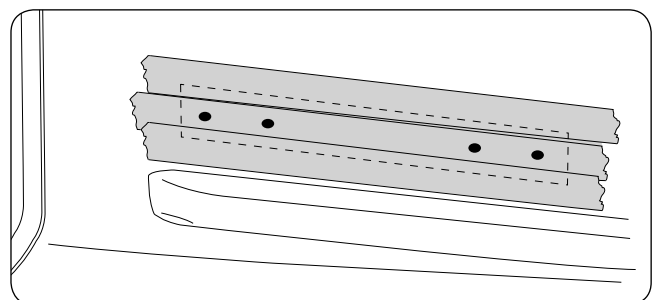



## RLZ02 - Rear Cross Bar, Ford Transit Connect.

### 9 Drill eight holes.

- Use a  $\varnothing 5\text{mm}$  (13/64) drill bit with drill stop. Drill through the roof in eight spots.
- Use a vacuum to remove the swarf from the roof.
- Remove masking tape and clean the area.

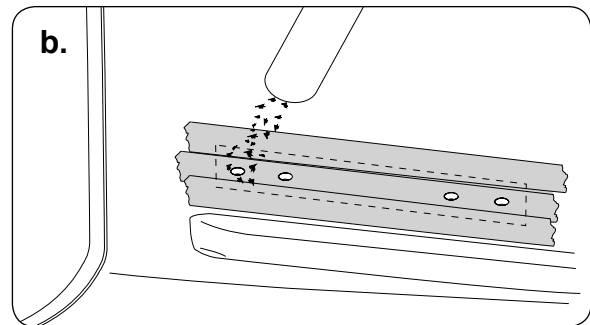
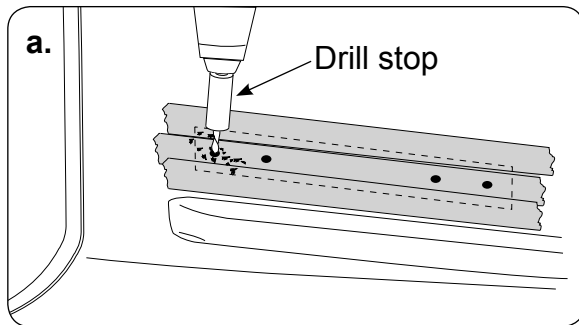

### 10 Treat holes.

- Paint over the holes with a Galvanising solution to prevent rust.
- Squirt a silastic sealer around holes to prevent water leaks.

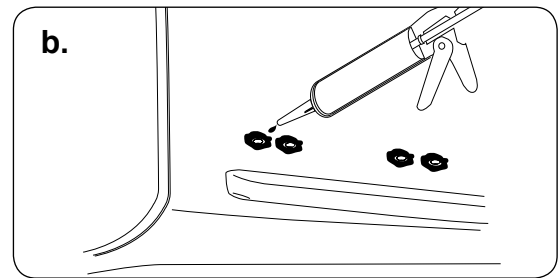
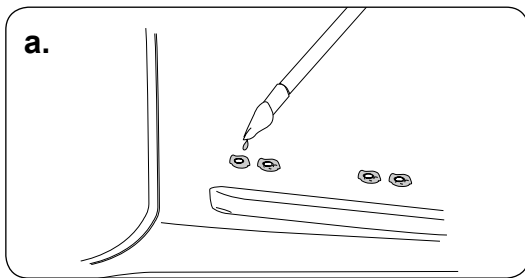

### 11

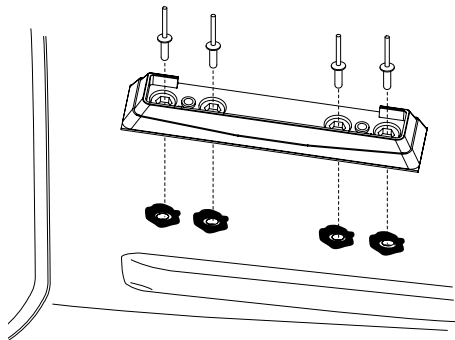

#### Fix pads to roof.

Rivet the fixed mount pads in place.

### 12 Fit roof rack.

Reassemble the rack as described in Steps 3 & 4. Do not fully tighten bolts or screws at this stage.

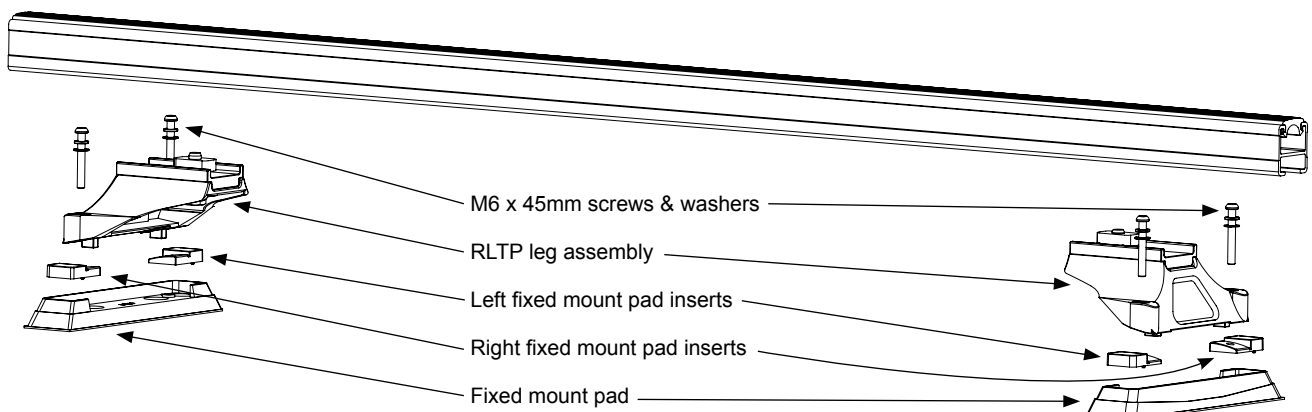



## RLZ02 - Rear Cross Bar, Ford Transit Connect.

### 13 Cross bar over hang.

Use a tape measure to obtain equal cross bar over hang. Tighten each M6 x 45mm leg screw to 3-4 Nm (2-3 ft lb). Tighten the M10 x 35mm cross bar bolts to 15-17 Nm (11-13 ft lb).

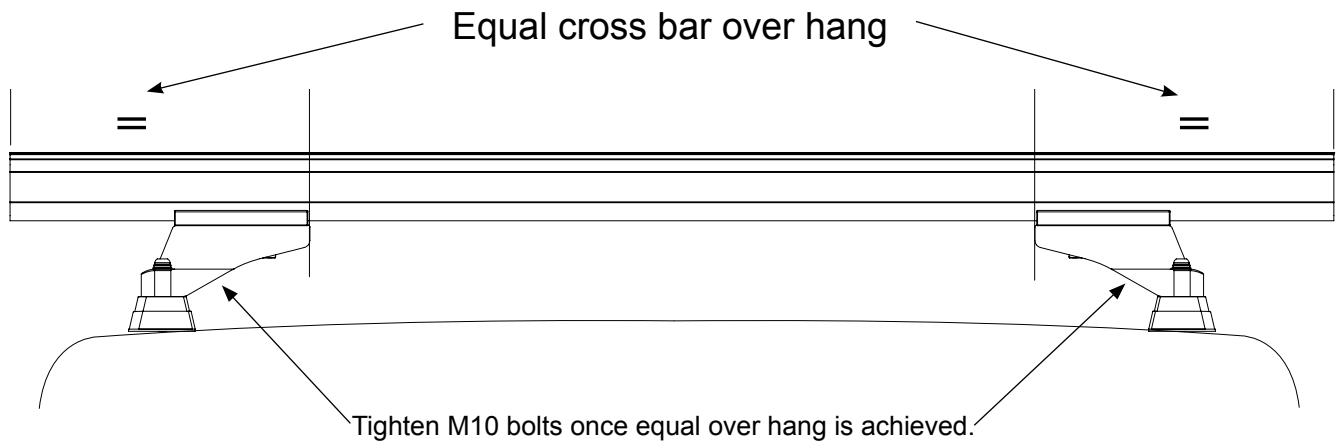

### 14

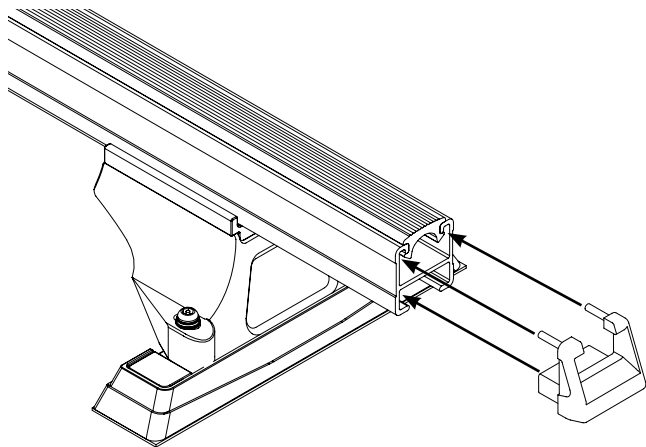

#### Fit end caps.

Trim the rubber buffer strip with a utility knife if it extends past the end of the cross bar. Fit the end caps to the cross bars. A rubber mallet may be needed to knock them in.

### 15

