



RHINO-RACK

Rhino-Rack Fairing (RF1, RF2, RF3, RF4)

Important: Please read these instructions carefully prior to installation. Please refer to your fitting instruction to ensure that the fairing is installed in the correct locations. Check the contents of kit before commencing fitment and report any discrepancies. Place these instructions in the vehicle's glove box after installation is complete.

Layout

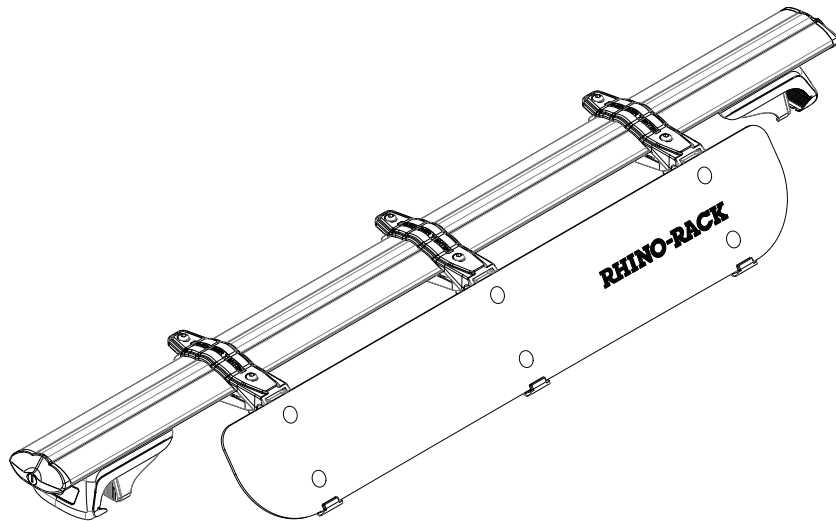

Important Information

Recommendations:

It is essential that all bolt connections be checked after driving a short distance when you first install your cross bars. Bolt connections should be checked again at regular intervals (probably once a week is enough, depending on road conditions, usage, loads and distances travelled). You should also check the cross bars each time they are re-fitted. Make sure to fasten your load securely. Please ensure that all loads are evenly distributed and that the centre of gravity is kept as low as possible.

Use only non-stretch fastening ropes or straps. Do not use fairing as a tie off point. Always lash around crossbar
Sensitivity to cross winds, behaviour in curves and braking. The handling characteristics of the vehicle, changes when you transport a load on the roof. For safety reasons, we recommend you exercise extreme care when transporting wind-resisting loads; special consideration must be taken into account when braking.

Please remove cross bars when putting vehicle through an automatic car wash. Clean fairing with smooth cloth using water or mild washing liquid. Damage to plastic may occur if the washing liquid is too strong or concentrated. Raise fairing slightly when cleaning the vehicle roof.

Rhino Rack do not take responsibility for damage to vehicle paintwork caused by this product. The best materials have been selected to minimise the impact of the contact between automotive grade rubber and the paintwork. It is the responsibility of the end user to determine the suitability of this product with their vehicle.

Note for Dealers and Fitters:

It is your responsibility to ensure instructions are given to the end user or client.



Rhino-Rack Fairing (RF1, RF2, RF3, RF4)

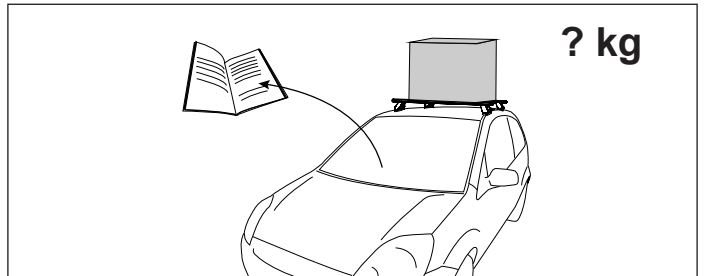
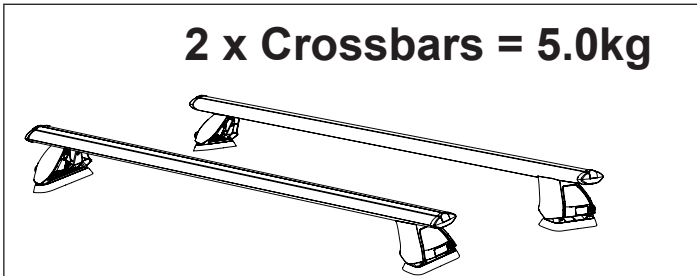
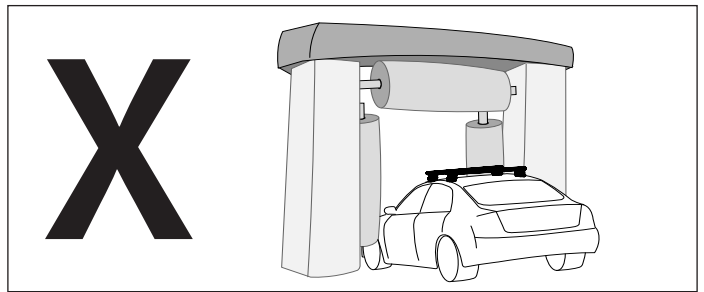
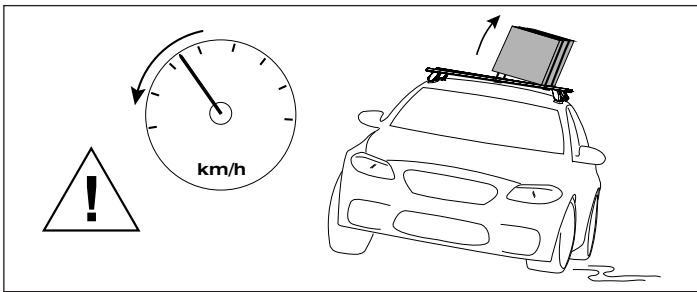
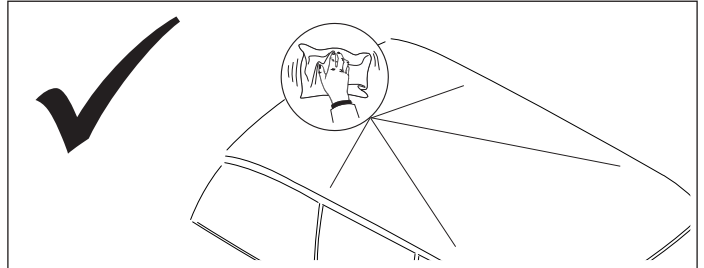
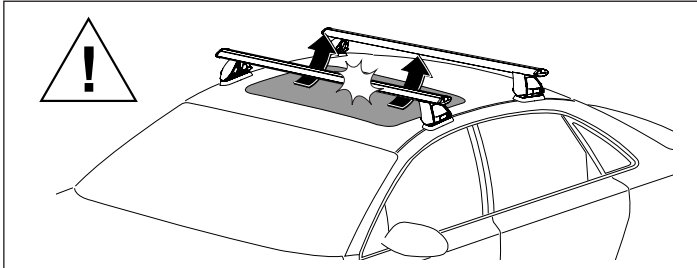
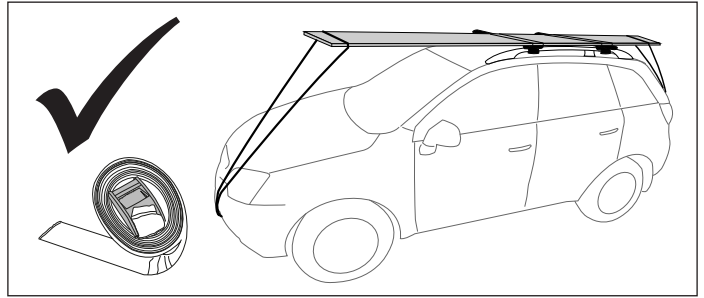
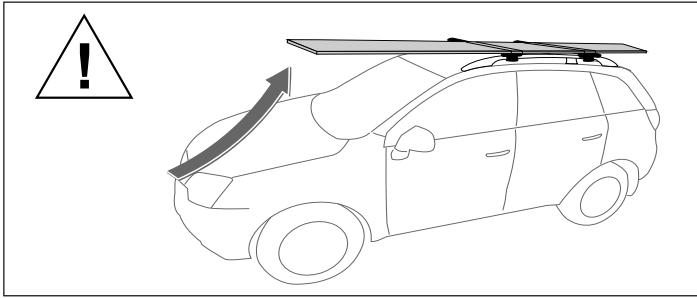

When these roof racks are to be used on a vehicle that is driven off sealed roads, the manufacturer maximum roof load rating (to be found in the vehicles User Manual) should be **halved**. Do not forget to subtract 7.5kg from your maximum carrying capacity due to the weight of the crossbars and legs.

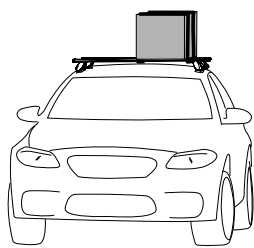

$$60\text{kg load rating (Urban road)} = 30\text{kg load rating (Off road - } 60\text{kg} / 2)$$

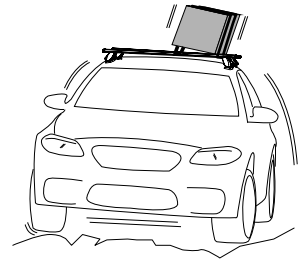

WARNING! Important Load Carrying Instructions

With utility vehicles, the cabin and the canopy move independently. Roof racks and vehicle can be damaged if the item transported is rigidly fixed at points on both the cabin and canopy. Instead, rigidly fix to either the cabin roof racks or the canopy roof racks.

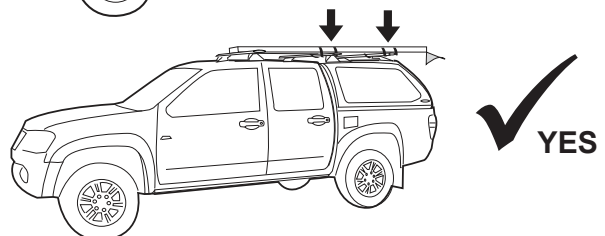
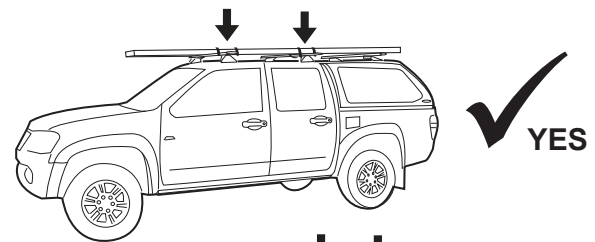
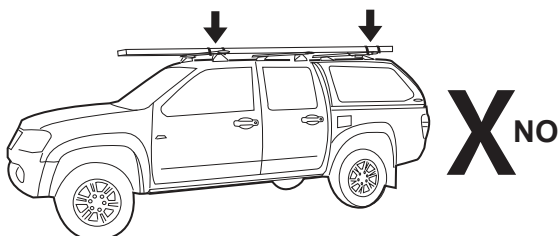



Rhino-Rack Fairing (RF1, RF2, RF3, RF4)

Parts List

Item	Component Name	Qty (RF1)	Qty (RF2, RF3, RF4)	Part No.
1	M6 x 35mm Button Head Screw (Black)	6	8	
2	M6 Flat Washer (Black)	6	8	W003-BLK
3	Upper Clamp Assembly	3	4	M627, M628
4	Bottom Clamp Assembly	3	4	M530
5	Rubber Bumper	3	4	M632
6a	Fairing RF1 (32")	1	-	
6b	Fairing RF2 (38")	-	1	
6c	Fairing RF3 (44")	-	1	
6d	Fairing RF4 (50")	-	1	
7	Button Clip	6	8	CA1141
8	4mm Allen Key	1	1	H001
9	Fitting Instruction	1	1	R286

Tools Required:

Security Allen key, provided in kit.

MAX width 90mm
MIN width N/A

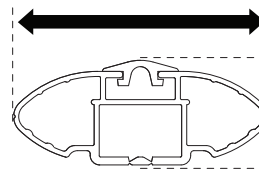

MAX height 33mm
MIN height 22mm



RF1 Parts List

Additional RF2, RF3 & RF4 Parts

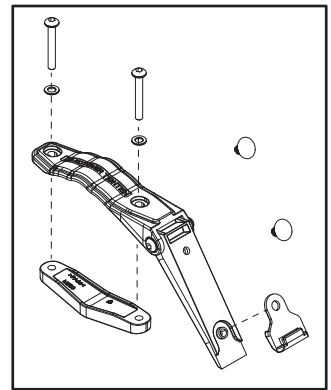
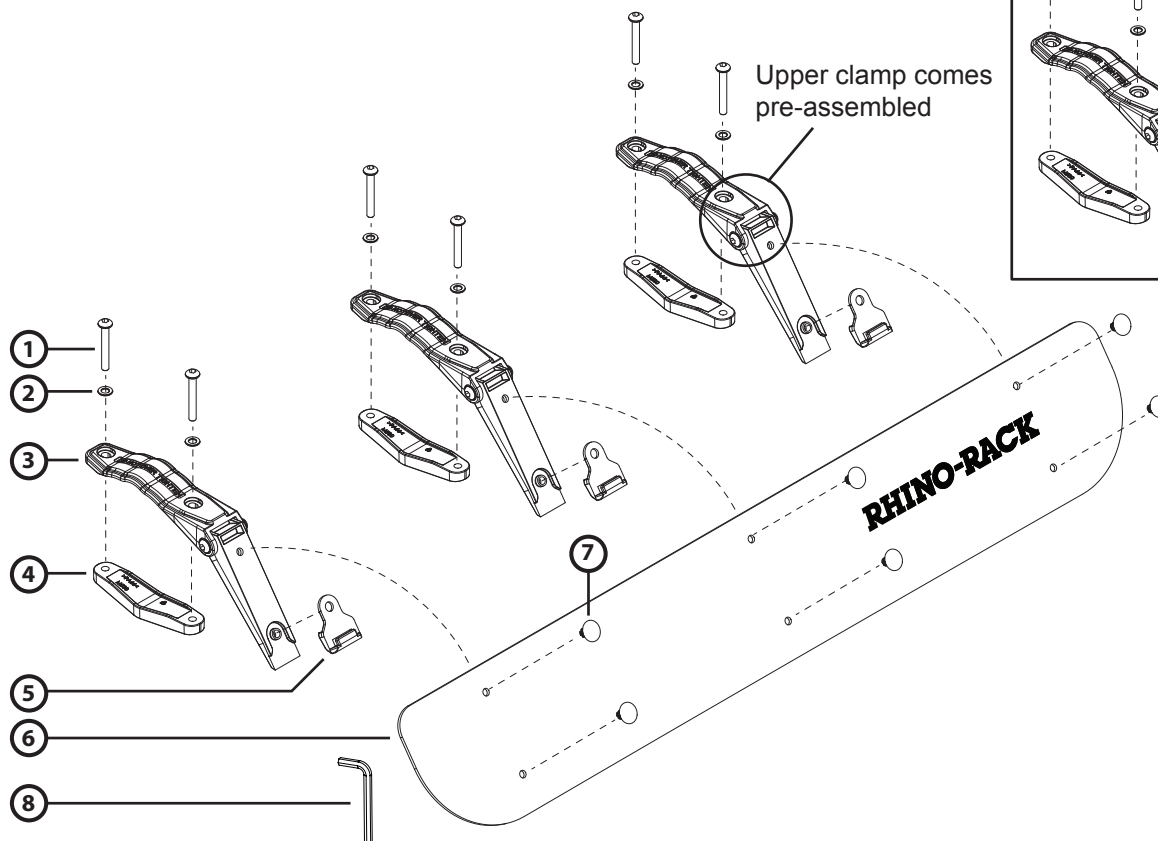



Rhino-Rack Fairing (RF1, RF2, RF3, RF4)

Fitting instructions (RF1 shown here)

- 1 Measure the distance between your rails and your crossbar legs before selecting the appropriate fairing for your vehicle.

RF1

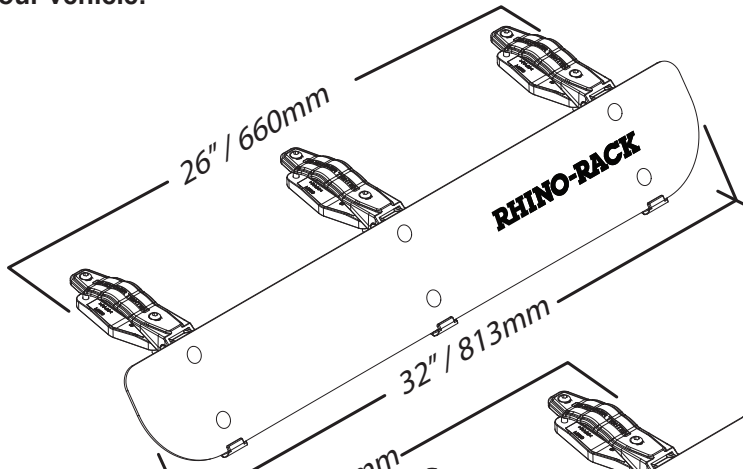

RF2

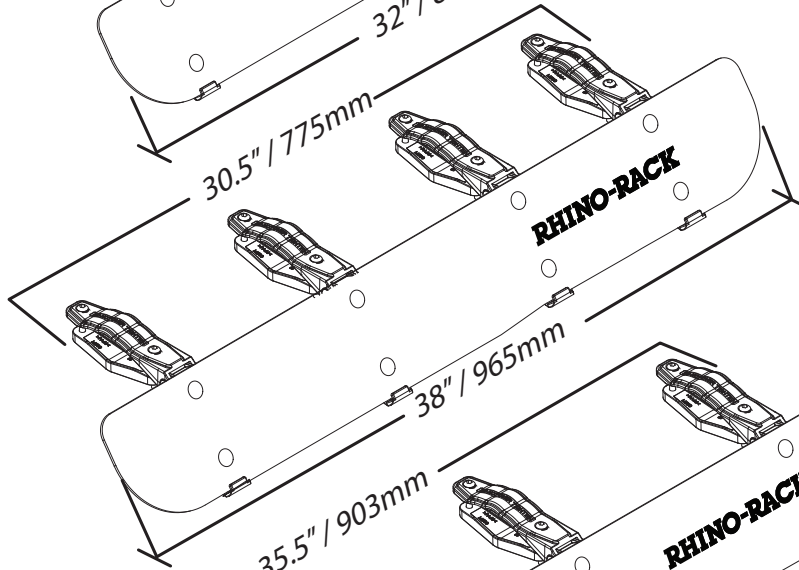

RF3

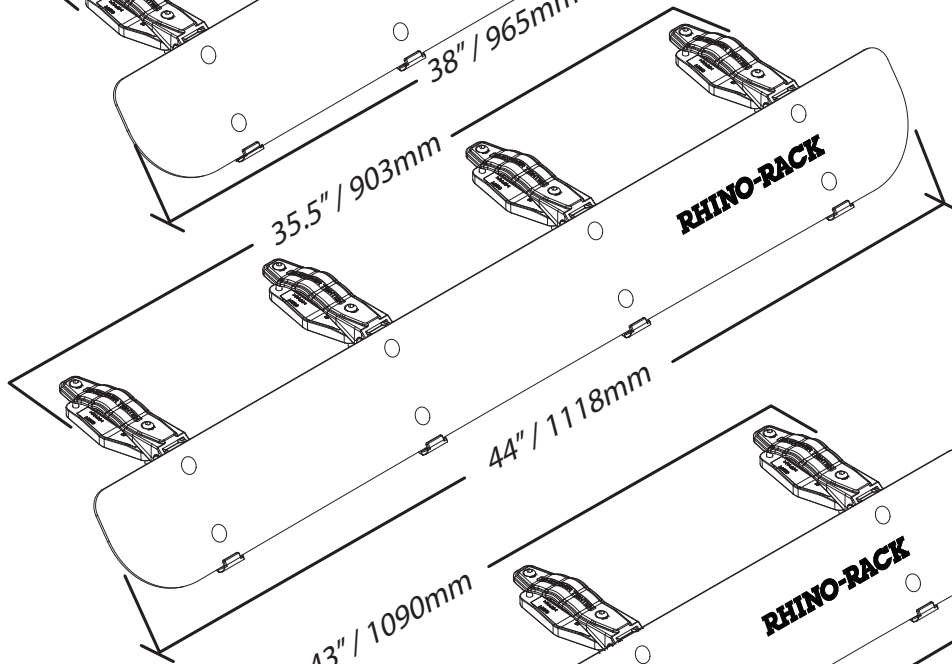

RF4

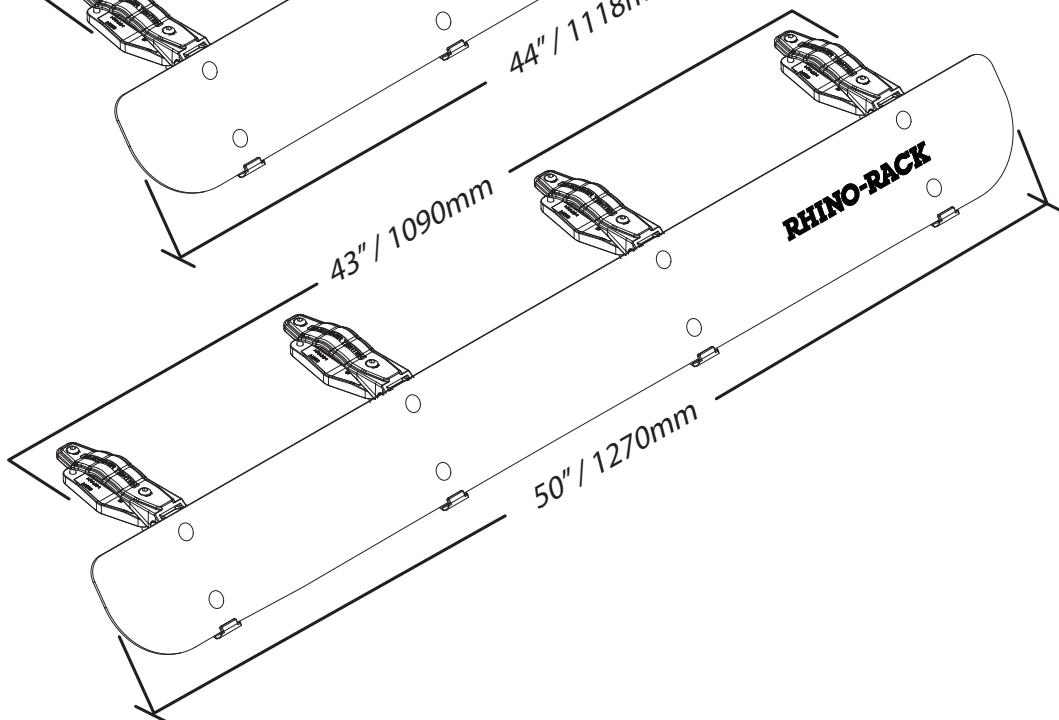



Rhino-Rack Fairing (RF1, RF2, RF3, RF4)

- 2** Make sure that there are sufficient clearances for the fitment of the fairing.

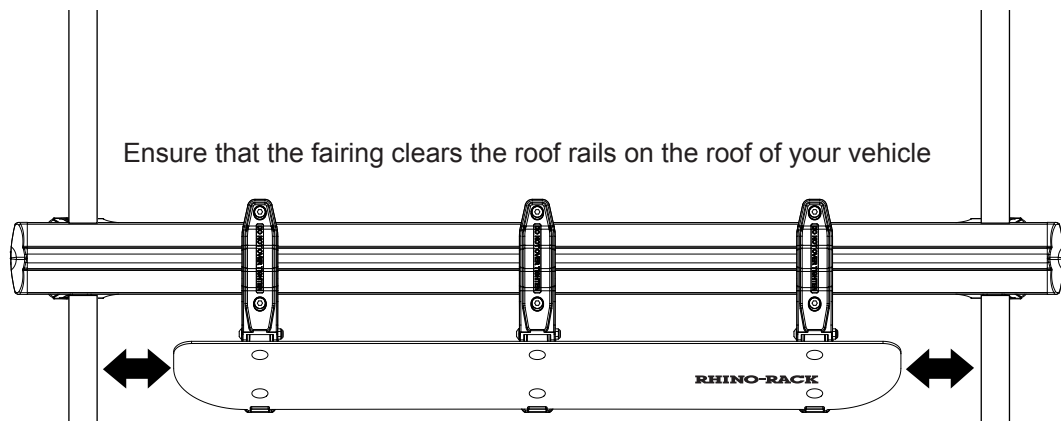

- Make sure that the upper clamp assembly does not interfere with the crossbar legs as shown

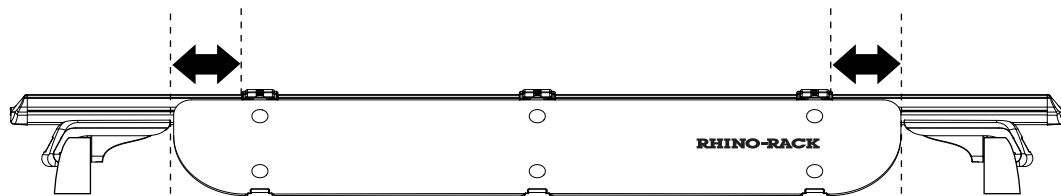

- 3** Assemble fairing as shown, only insert one bolt assembly for the moment so it'll be easy to mount onto the crossbar. Do not tighten fully, keep it loose.

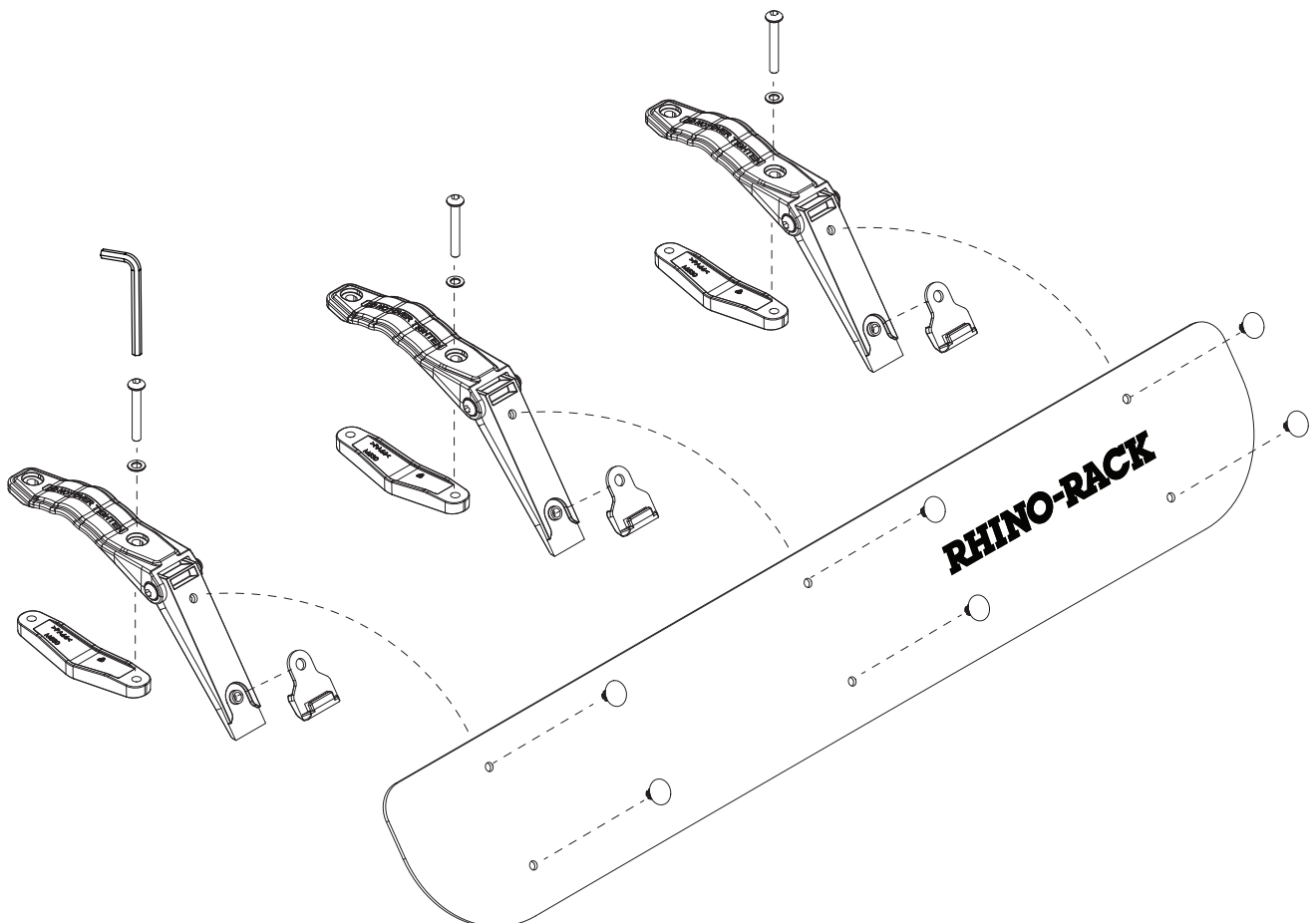



Rhino-Rack Fairing (RF1, RF2, RF3, RF4)

4 Mount fairing onto crossbar (Rhino Aero shown here).

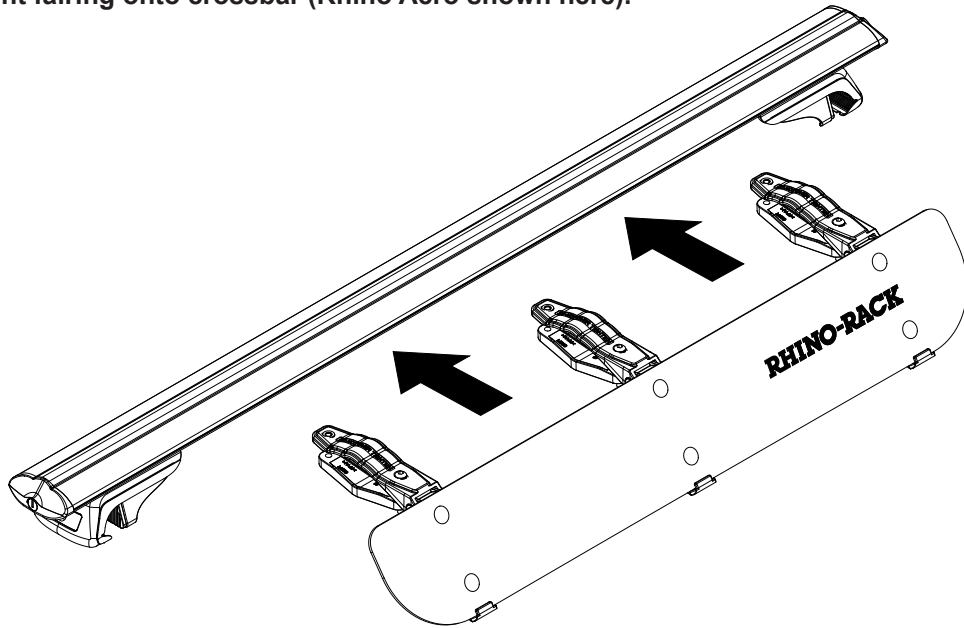

5 Tighten M6 bolts evenly across the upper clamp assembly. Ensure that the fairing is mounted centrally on the crossbar.

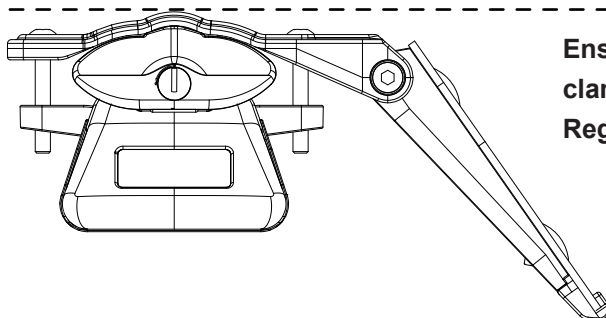
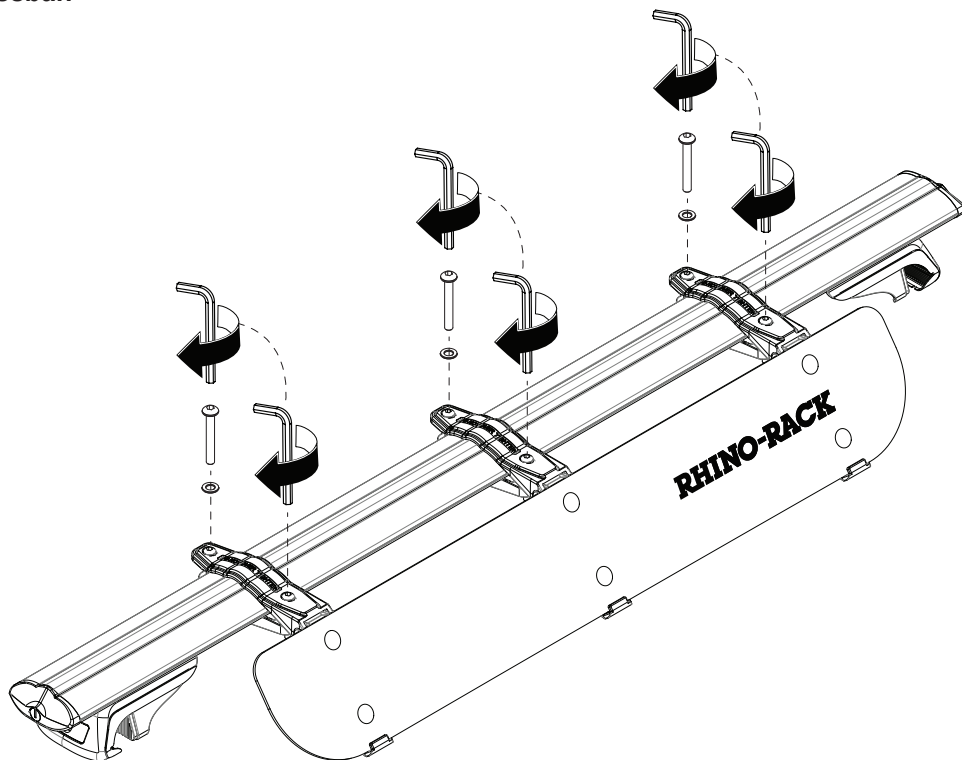

Ensure that the load does not damage the plastic clamp brackets (sits above the dotted line as shown). Regularly inspect and replace if necessary.