



RHINO-RACK®

Reconn-Deck Track Mount Instructions RD-FK1, RD-FK2, RD-FK3

Important:

1. Check the Rhino-Rack website to ensure you have the latest issue of these instructions.
2. Please refer to your fitting instruction to ensure that the roof racks are installed in the correct locations.
3. Check the contents of kit before commencing fitment and report any discrepancies.
4. Place these instructions in the vehicle's glove box after installation is complete.
5. These instructions must be followed for warranty to be upheld.

Fit Time: 5 mins

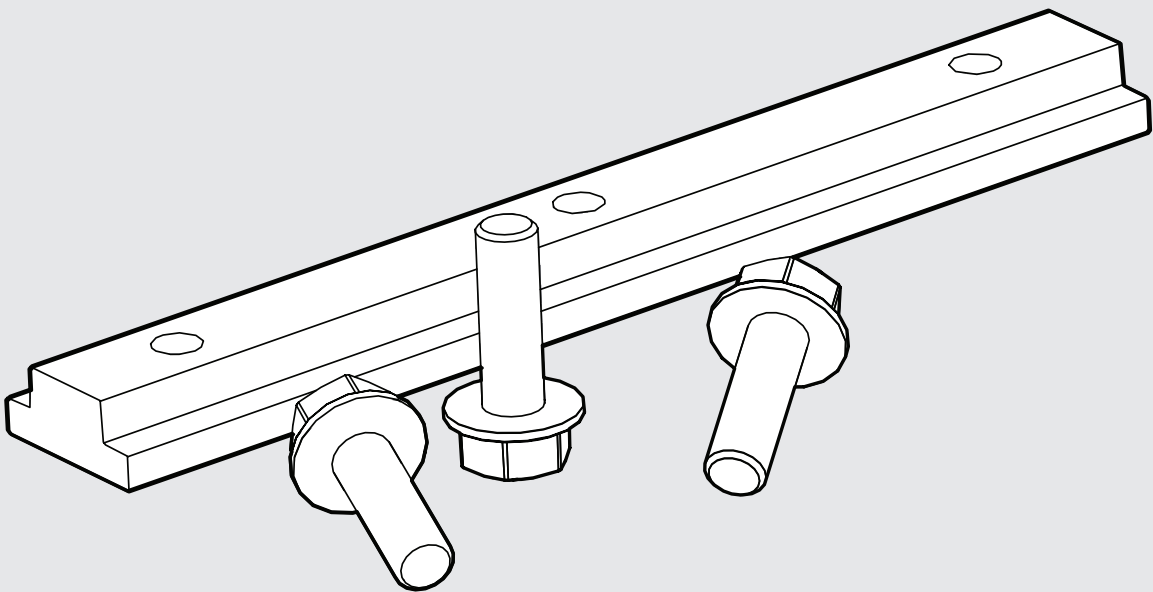

RD-FK Instructions

Check the website and the vehicle owners hand book for your vehicle manufacturer's maximum carrying capacity. Load must be evenly distributed over the system.



Cargo Load Lim

Total permissible weight allowed on top, and attached to the bed rack whilst the vehicle is in motion.

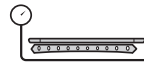

System weight

Total weight of the rack system. (Crossbars, Backbone, Platform)



Max System Load Capacity

Please ensure you use the vehicle manufacturer's maximum bed rack allowance if it is lower than the figure listed in the fitting chart/supplement.



Vehicle Manufacturer's Load Limit

Total permissible weight attached to the bed rack. This is inclusive of the weight of the bed rack system.

Warning

- Check part number or kit is correct for use with your vehicle.
- Do not attempt to fit the bed rack system to your vehicle unless you fully understand these fitting instructions. Please direct any questions regarding fitting to the dealer from where the roof racks were purchased.
- Off-road conditions can be much more rigorous. Extreme care must be taken on any driven path that does not contain a surface protection layer (tar/bitumen).
- Bed racks must be removed when vehicle is put through an automatic car wash.
- With utility/pick up vehicles, the cabin and the truck bed move independently. Bed racks and vehicle can be damaged if the item transported is rigidly fixed at points on both the cabin and truck bed. Instead, rigidly fix to either the bed racks or the canopy roof racks.
- Always ensure you fasten your load securely.
- Use only non-stretch fastening ropes or straps to attach cargo to your load.

In service maintenance checks

- All bolt connections should be checked after driving a short distance when you first install your roof racks.
- All bolted connections should be checked again at regular intervals (weekly is recommended, depending on road conditions, usage, loads and distances travelled).
- All bolted connections should be checked each time they are re-fitted.
- Off-road conditions are more rigorous. Check all bolted connections and your load more regularly.
- Ensure that your vehicle manufacturer's GVM, and gross axle weights are not exceeded (refer to vehicle owner's manual).

Torque Settings

Unless stated otherwise in these instructions, all fasteners should be set to the following torque settings:

M6: 4-5Nm (3-4lbs/ft),

M8: 8-10Nm (6-7.5lbs/ft)

M10: 16-18Nm (12-13lbs/ft).

Note for Dealers and Fitters

It is your responsibility to ensure these fitting instructions are given to the end user or client. These instructions remain the property of Rhino-Rack Australia Pty. Ltd. and may not be used or changed for any other purpose than intended.

System Components

To complete the Reconn-Deck system you will need the base, tower & bar kits (accessories are recommended)

RECONN-DECK SYSTEM COMPONENTS

BASE

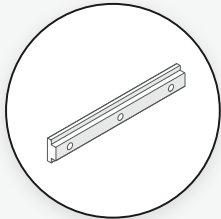

TOWER

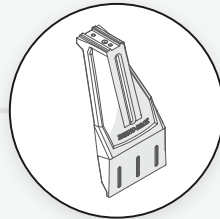

BARS

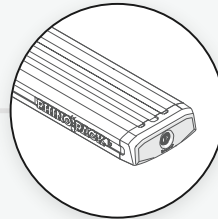

ACCESSORY

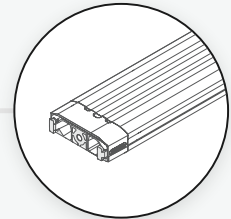

BASE Parts List

Track nuts vary between each vehicle. Visit the website (QR code below for mobile phones) and refer to your vehicle's supplement fitting sheet for vehicle specific track nut

RD-FK1 Track nut 63mm long

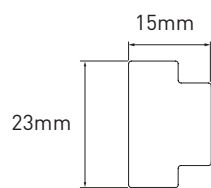
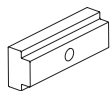

A1 x12

M8 x 30 bolt



B1 x12

Instruction



C1 x1

RD-FK2 Track Nut 166mm long

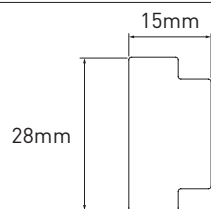
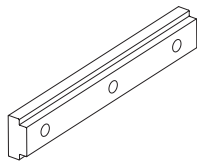

A2 x4

M8 x 30 bolt



B2 x12

Instruction



C2 x1

RD-FK3 Track Nut 166mm long

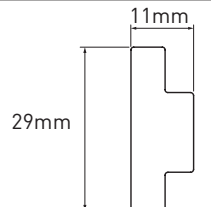
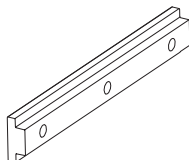

A3 x4

M8 x 30 bolt



B3 x12

Instruction



C3 x1

1 Track nut installation varies between each vehicle.

1A Repeat to opposite side. Install **B** when fixing towers.

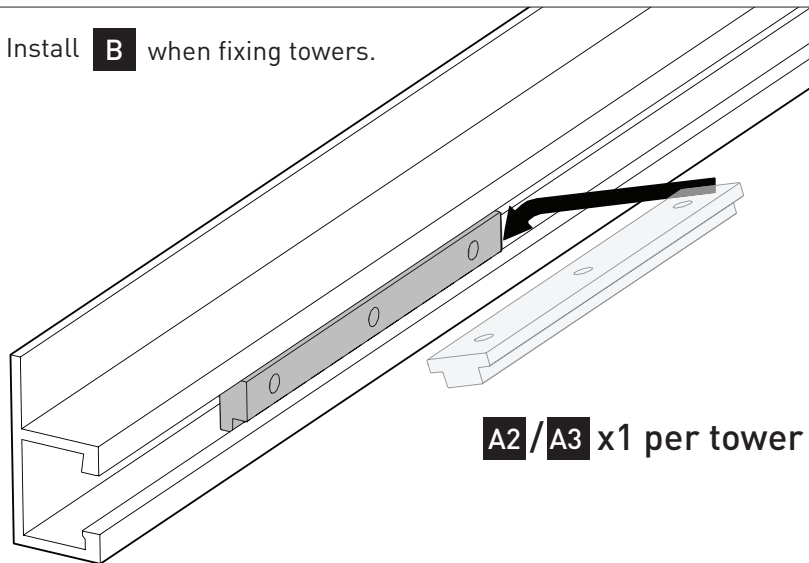

1B

Install **B** when fixing towers.

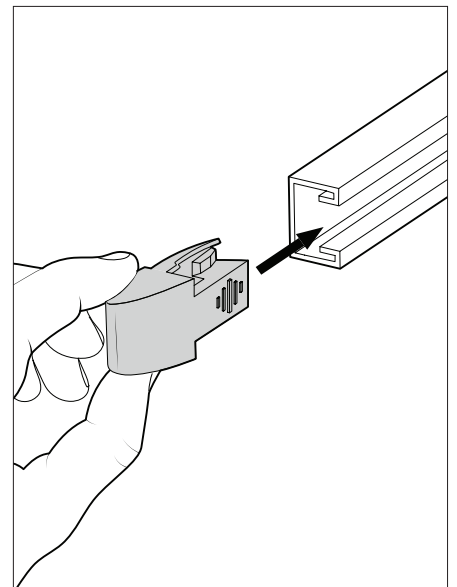
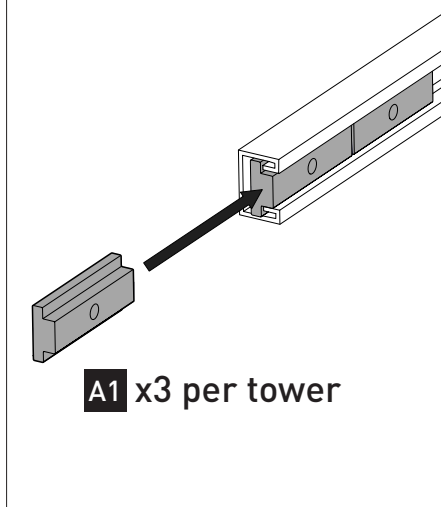
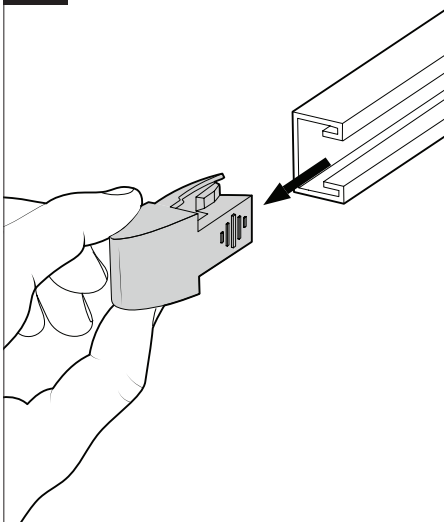

1C Repeat to opposite side. Install **B** when fixing towers.

