



RHINO-RACK

BASE KIT - RCP68-BK

Important:

1. Check the Rhino-Rack website to ensure you have the latest issue of these instructions.
2. Please refer to your vehicle specific fitting instruction to ensure that the roof racks are installed in the correct locations.
3. Check the contents of kit before commencing fitment and report any discrepancies.
4. Place these instructions in the vehicle's glove box after installation is complete.
5. These instructions must be followed for warranty to be upheld.

Fit Time: 1 hour

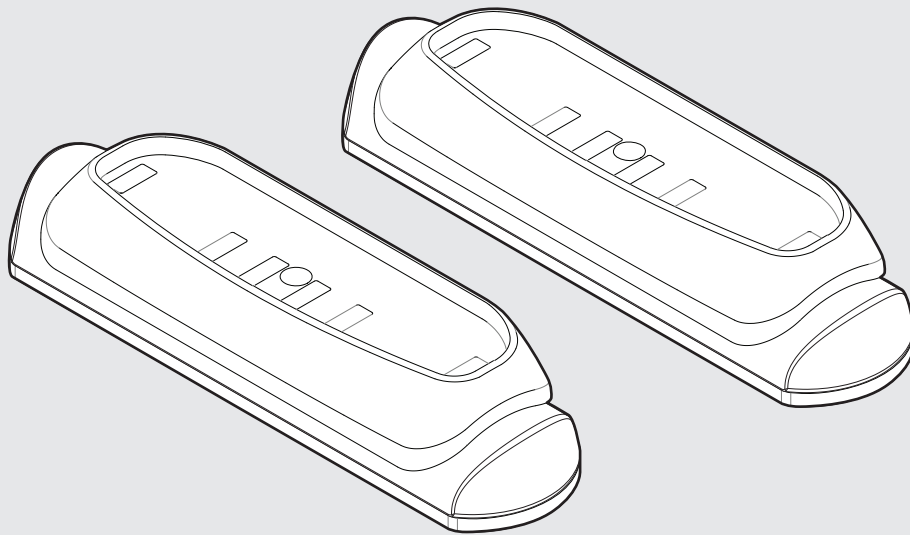

RCP68-BK Instructions

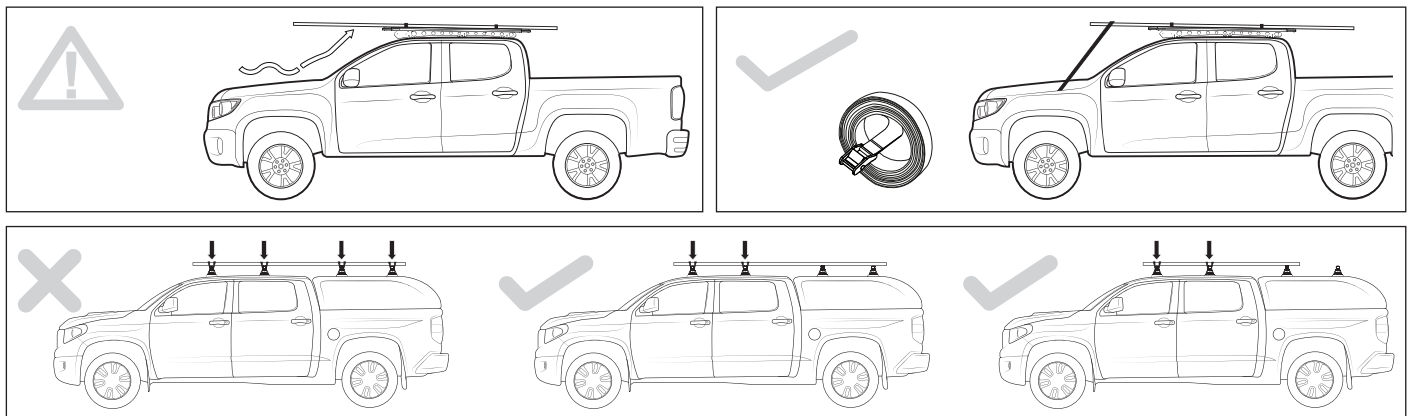

Max system load capacity (incl. system weight), refer to vehicle specific fit sheet.

Check your vehicle owners hand book for vehicle maximum carrying capacity. Please ensure you use the vehicle manufacturers maximum roof allowance if it is lower than the figure listed in these instructions.

Load must be evenly distributed over the system.

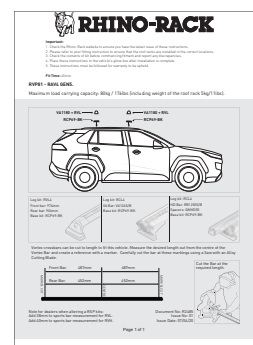

Off Road: Any driven path taken that does not contain a surface protection layer (tar/bitumen).

Vehicle Load Limit: Total permissible weight attached to the roof of the car. This is inclusive of the weight of the roof rack system.

System Load Limit: Total permissible weight allowed on top, and attached to roof racks whilst the vehicle is in motion.

Static Allowance: Total permissible weight allowed on top, and attached to roof racks whilst the vehicle is stationary.

Torque Settings

Unless stated otherwise in these instructions, all fasteners should be set to the following torque settings - M6: 4-5Nm (3-4lbs/ft), M8: 8-10Nm (6-7.5lbs/ft) and M10: 16-18Nm (12-13lbs/ft).

Warning

- Check part number/ or kit is correct for use with your vehicle.
- Do not attempt to fit the rack system to your vehicle unless you fully understand these fitting instructions. Please direct any questions regarding fitting to the dealer from where the roof racks were purchased.
- Although the system is tested and approved to AS1235-2000 / ISO 11154, off-road conditions can be much more rigorous. Extreme care must be taken in off road conditions.
- Roof racks must be removed when vehicle is put through an automatic car wash.
- With utility vehicles, the cabin and the canopy move independently. Roof racks and vehicle can be damaged if the item transported is rigidly fixed at points on both the cabin and canopy. Instead, rigidly fix to either the cabin roof racks or the canopy roof racks.
- Always ensure you fasten your load securely.
- Use only non-stretch fastening ropes or straps to attach cargo to your load.
- Clean vehicle/ rails before fitting roof rack.

In service maintenance checks

- All bolt connections should be checked after driving a short distance when you first install your roof racks.
- All bolted connections should be checked again at regular intervals (weekly is recommended, depending on road conditions, usage, loads and distances travelled).
- All bolted connections should be checked each time they are re-fitted.

Note for Dealers and Fitters

It is your responsibility to ensure these fitting instructions are given to the end user or client. These instructions remain the property of Rhino-Rack Australia Pty. Ltd. and may not be used or changed for any other purpose than intended.

RCP68-BK Instructions

Parts List

Item	Description	Qty
A	Top pad	4
B	Bottom pad	4
C	Base gasket	4
D	M6 adaptor	4
E	M6 x 45mm hex bolt	4
F	M6 spring washer	4
G	M6 flat washer	4
H	M8 flat washer	4
I	Instruction	1

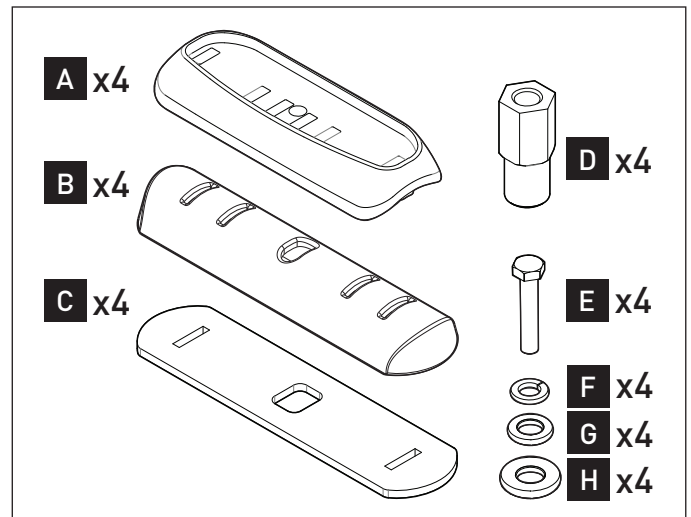

-Tools required:

T1-10mm socket wrench and spanner. T3 - Masking tape.
 T2 - Safety pin (some vehicles). T4 - 2mm right angle pick (some vehicles).

Instruction steps

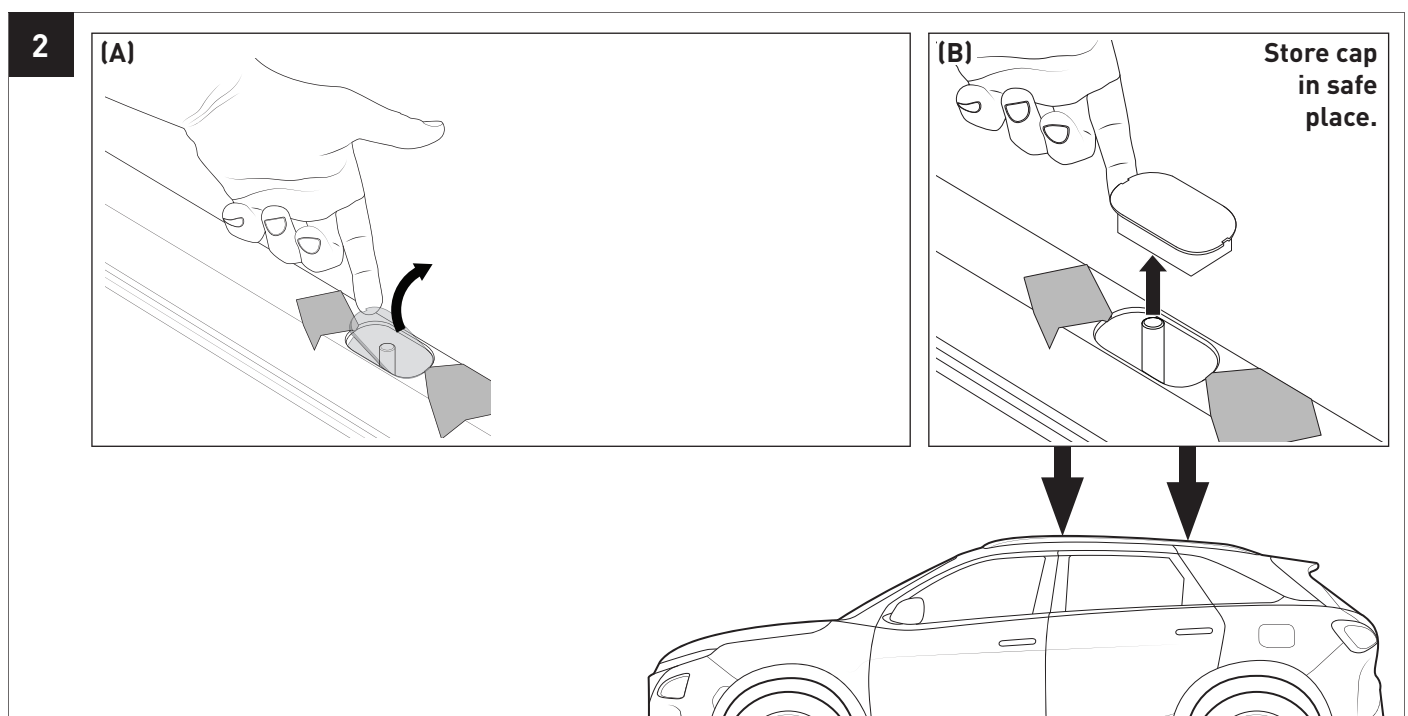
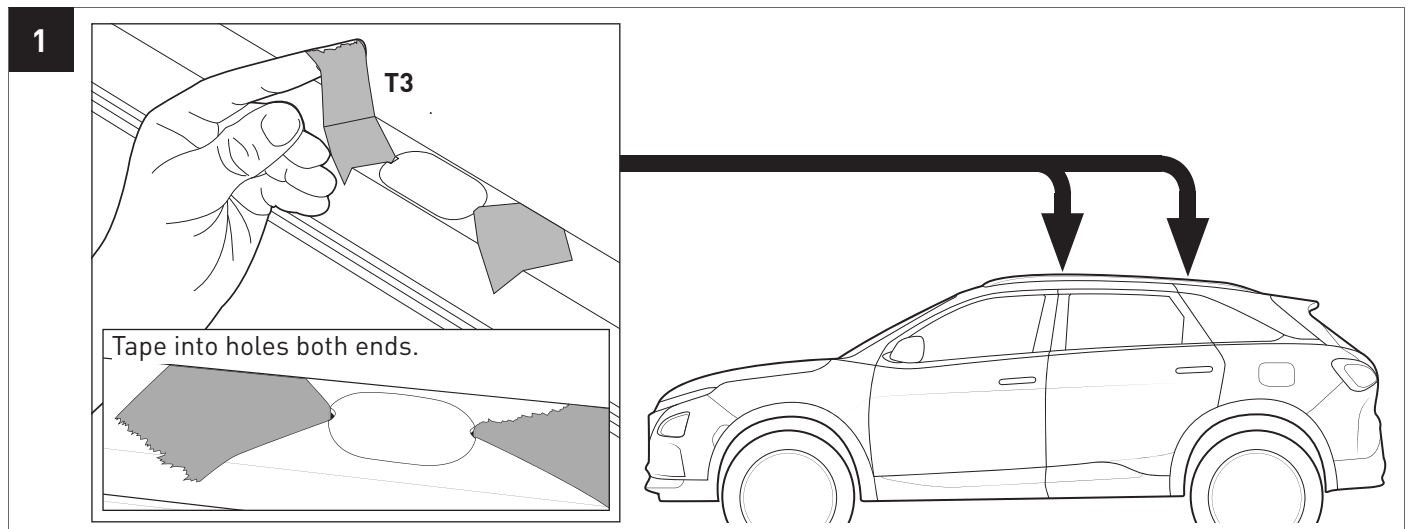

3

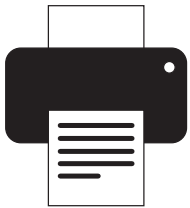

RVPxx document

