

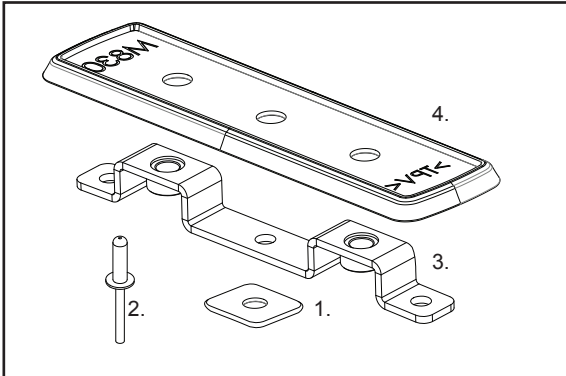

RHINO-RACK

QMFK08 - Quick Mount Roof Ditch Bracket

Important: Please read these instructions carefully prior to installation. Check the contents of this kit before commencing fitment and report any discrepancies. Place these instructions in the vehicle's glove box after installation is complete.



Item	Component Name	Qty	Part No.
1	Butyl Patch 20mm x 20mm	6	CA1266
2	5mm Rivet	6	H008
3	Roof Ditch Bracket	2	CA1506
4	RLT600 Low Gasket Skirt	2	M830
5	Instructions	1	R797

Tools Required:

- Power Drill
- Pneumatic or concertina rivet gun
- 5mm drill bit
- Masking tape
- Drill stop (set to 5mm)
- Nylon Scrape or similar
- Cutters
- *Caulking Gun Butyl Mastic
- Cold Galvanising Paint, buds

1 Using your vehicle specific fitment instruction mark the intended locations on the ditch rubber of the Brackets. **Note: Use figure below as a reference only. Vehicle fitments will vary from vehicle to vehicle.** (X) and (Y) measurements will be referenced in vehicle specific Ditch Bracket Instructions downloaded at the RhinoRack website. Select make and model then select the Roof Ditch Bracket Fit Kit.

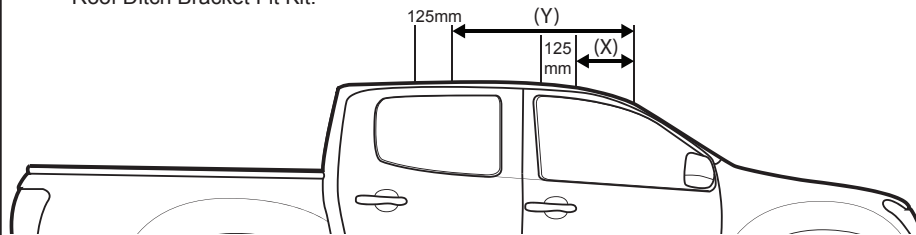

With the (x) and (y) measurements recorded onto the roof ditch. Measure back 125mm from both of these points and mark another line.

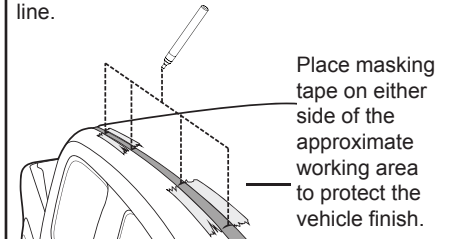

2 Using a nylon scrape or similar, lift out the section of ditch rubber previously marked. **Note:** Care must be taken here to avoid damaging the paint work of the roof, do not use metal tools to complete this section. Carefully cut along the marks and remove the section of ditch rubber required. **Note: Use figure below as a reference only. Vehicle fitments will vary from vehicle to vehicle.**

Note: Carefully lift either the front or rear of the Ditch Mould out. Sit a Bracket and RLT600 Base on the Bracket. The Ditch must not interfere with the assembly for installation to be successful.

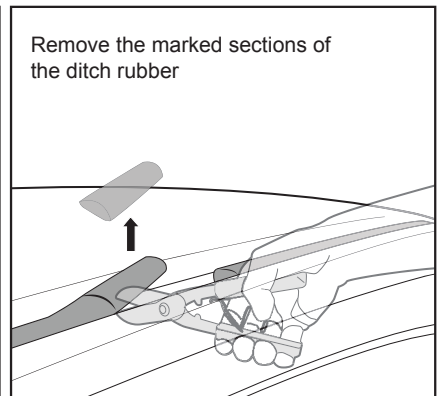
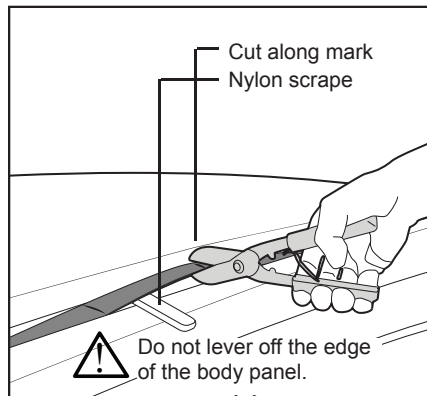
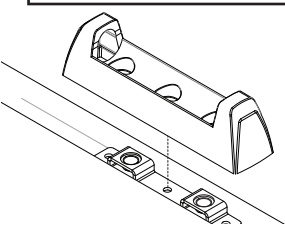
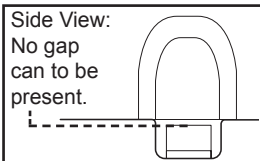

3 Check for excess filler in the uncovered ditch. Clean out the ditch.

Body filler may be present in the sections of removed ditch rubber. Clean out thoroughly.

*Coat any chipped paint with Cold Gal and re-seal any exposed panels joins with Butyl Mastic.

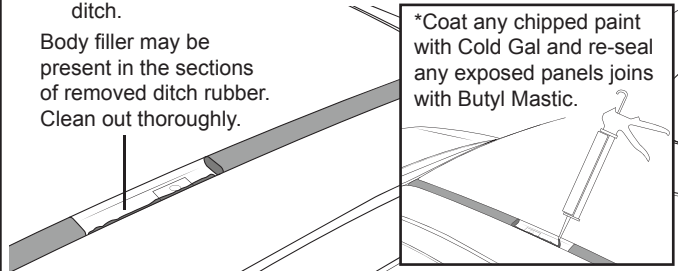

4 Place the Ditch Brackets into position.

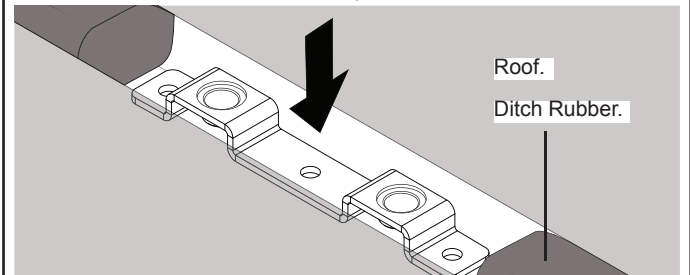



QMFK08 - Quick Mount Roof Ditch Bracket

5 Mark the positions of the mounting holes onto the roof ditch.

Be sure Brackets are parallel across the vehicle. This is required to correctly fit the legs and crossbars.

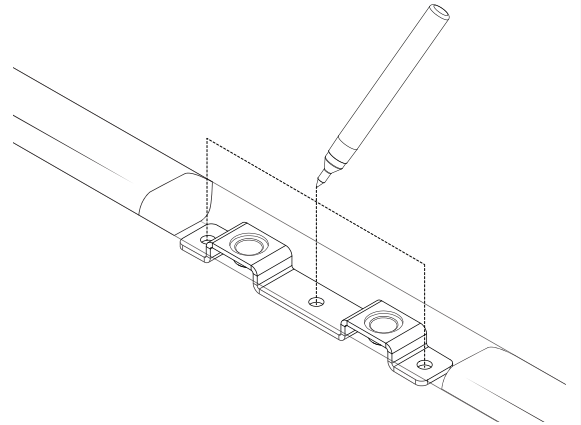
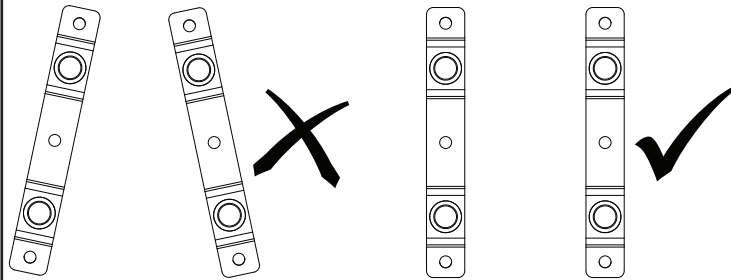

6 Drill out the markings with a 5mm drill bit and a drill stop set to 5mm.

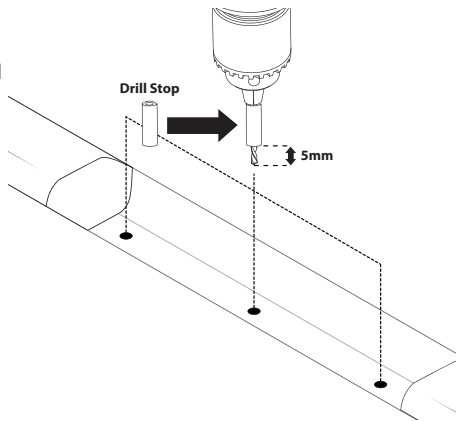

7 Vacuum any swarf. Then seal with a cold galvanising paint.

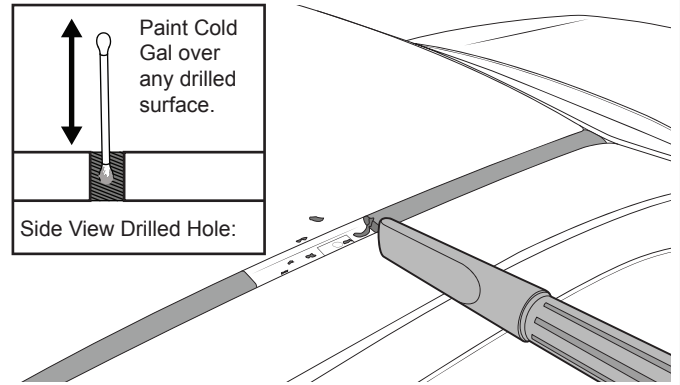

8 Apply Butyl Patches to ALL drilled holes in the Roof. 1: Remove the backing tape from the Butyl Patch. 2: Place over holes drilled in the roof ditch. 3: Remove tape from top of patches.

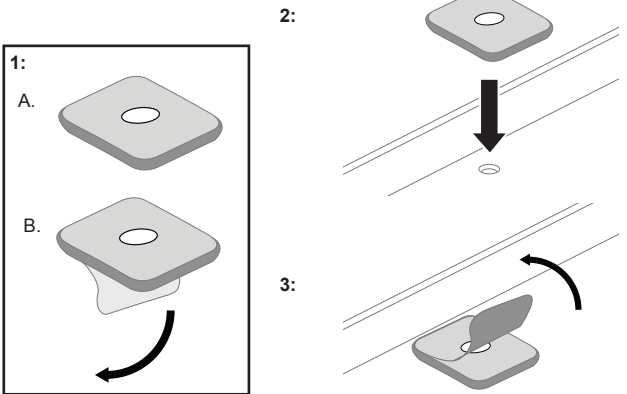

9 Place the Ditch Bracket onto the Butyl Patches. Press down on the Bracket, ensuring a good seal is formed.

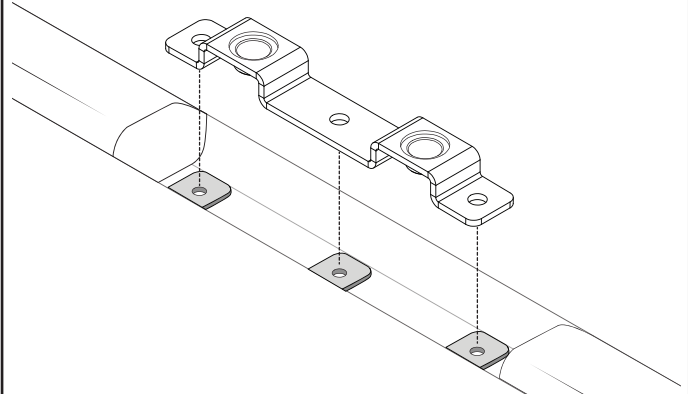

10 Place Rivets into the Brackets as shown. Use a pneumatic or conertina rivet gun to fix the brackets into place.

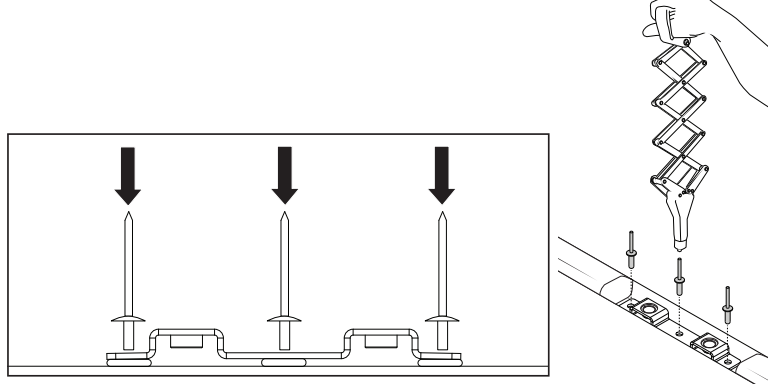

11 M830 will sit on top of the installed Bracket and is optional. The Gasket will cover exposed areas of the Bracket and Ditch Mould.

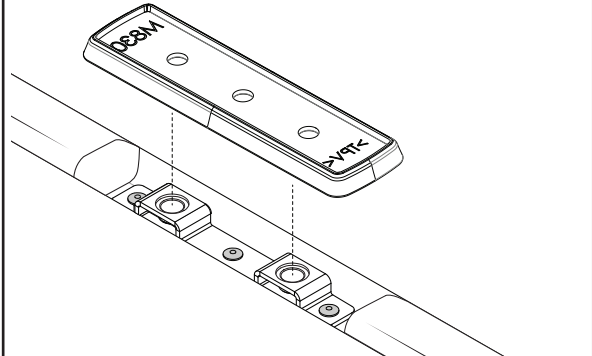

Fit Crossbars as per instructions found in kit.