



# RHINO-RACK®

## PIONEER ALLOY TRAY (flat pack)

**Important:**

1. Check the Rhino-Rack website to ensure you have the latest issue of these instructions.
2. Please refer to your fitting instruction to ensure that the roof racks are installed in the correct locations.
3. Check the contents of kit before commencing fitment and report any discrepancies.
4. Place these instructions in the vehicle's glove box after installation is complete.
5. These instructions must be followed for warranty to be upheld.

**Fit Time:** 1 hour

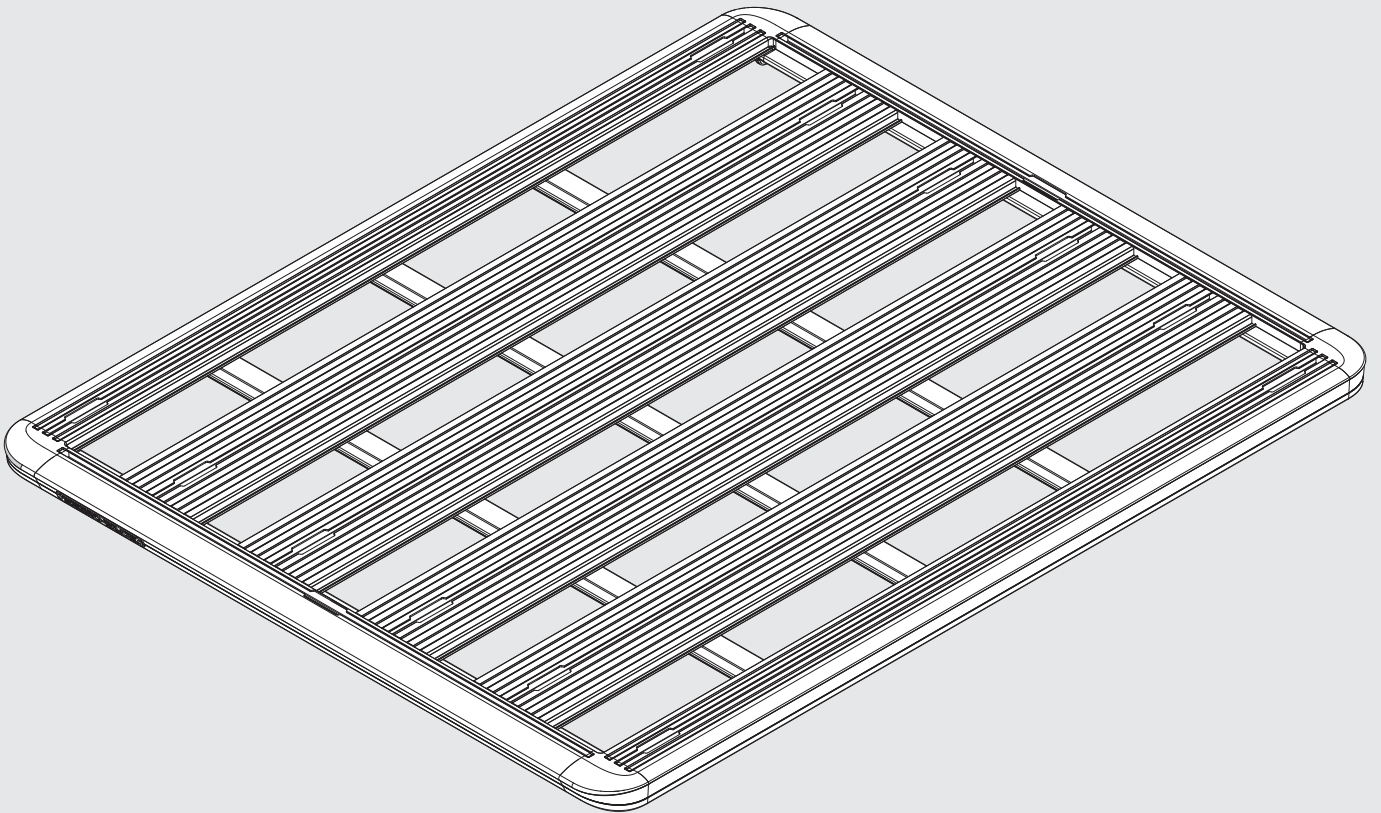

## Instructions - Instrucciones

---

### Carrying Capacity

**Max system load capacity (incl. system weight), refer to Pioneer fit sheet.**

Check your vehicle owners hand book for vehicle maximum carrying capacity. Please ensure you use the vehicle manufacturers maximum roof allowance if it is lower than the figure listed in this instruction.

Load must be evenly distributed over the system.

**Off Road:** Any driven path taken that does not contain a surface protection layer (tar/bitumen).

**Vehicle Load Limit:** Total permissible weight attached to the roof of the car. This is inclusive of the weight of the roof rack system.

**System Load Limit:** Total permissible weight allowed on top, and attached to roof racks whilst the vehicle is in motion.

### Torque Settings

Unless stated otherwise in these instructions, all fasteners should be set to the following torque settings - M6: 4-5Nm (3-4lbs/ft), M8: 8-10Nm (6-7.5lbs/ft) and M10: 16-18Nm (12-13lbs/ft).

### Warning

---

- Check part number or kit is correct for use with your vehicle.
- Do not attempt to fit the rack system to your vehicle unless you fully understand these fitting instructions. Please direct any questions regarding fitting to the dealer from where the roof racks were purchased.
- Although the system is tested and approved to AS1235-2000 / ISO 11154, off-road conditions can be much more rigorous. Extreme care must be taken in off road conditions.
- Roof racks must be removed when vehicle is put through an automatic car wash.
- With utility vehicles, the cabin and the canopy move independently. Roofracks and vehicle can be damaged if the item transported is rigidly fixed at points on both the cabin and canopy. Instead, rigidly fix to either the cabin roof racks or the canopy roof racks.
- Always ensure you fasten your load securely.
- Use only non-stretch fastening ropes or straps to attach cargo to your load.

### In service maintenance checks

---

- All bolted connections should be checked after driving a short distance when you first install your roof racks.
- All bolted connections should be checked again at regular intervals (weekly is recommended, depending on road conditions, usage, loads and distances travelled).
- All bolted connections should be checked each time they are re-fitted.

### Note for Dealers and Fitters

---

It is your responsibility to ensure these fitting instructions are given to the end user or client. These instructions remain the property of Rhino-Rack Australia Pty. Ltd. and may not be used or changed for any other purpose than intended.

# Instructions

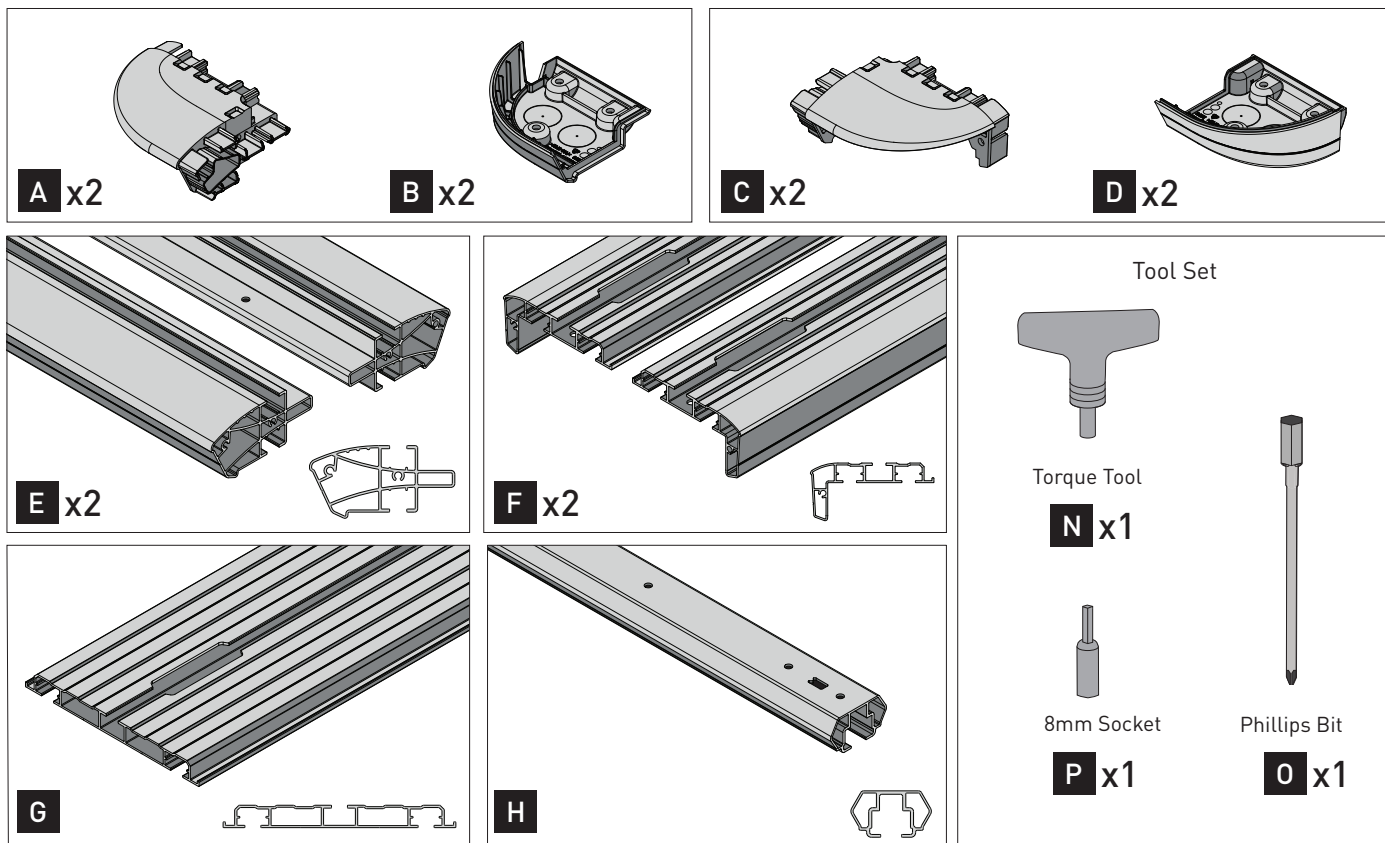

Platform #	L x W (mm)	L x W (inches)	G	H	I	J	K	L	M
52100	1528 x 1236	60' x 49'	4	3	52	52	12	16	6
52101	1528 x 1376	60' x 54'	5	3	62	62	12	16	6
52102	1928 x 1236	76' x 49'	4	5	76	76	12	16	6
52103	1928 x 1376	76' x 54'	5	5	90	90	12	16	6
52104	2128 x 1426	84' x 56'	5	5	90	90	12	16	N/A
52105	2728 x 1465	107' x 58'	5	6	104	104	12	16	N/A
52107	2128 x 1236	84' x 49'	4	5	76	76	12	16	N/A
52108	1828 x 1426	72' x 56'	5	5	90	90	12	16	N/A
52109	1328 x 1236	52' x 49'	4	3	52	52	12	16	N/A
52110	1328 x 1376	52' x 54'	5	3	62	62	12	16	N/A
52111	1328 x 1426	52' x 56'	5	3	62	62	12	16	N/A
52112	928 x 1426	37' x 56'	5	2	48	48	12	16	N/A
52113	1528 x 1426	60' x 56'	5	3	90	90	12	16	N/A
52114	1228 x 952	48' x 37'	3	1	22	22	12	16	N/A
52115	1478 x 1184	58' x 47'	4	1	28	28	12	16	N/A
52119	2528 x 1586	100' x 62'	5	6	104	104	12	16	N/A
52120	1528 x 1586	60' x 62'	5	3	62	62	12	16	N/A
52121	1228 x 1426	48' x 56'	5	3	62	62	12	16	N/A

**Tools required:**

**Herramientas necesarias:**

T1 - Phillips head screwdriver.

T2 - Power drill.

# Instructions

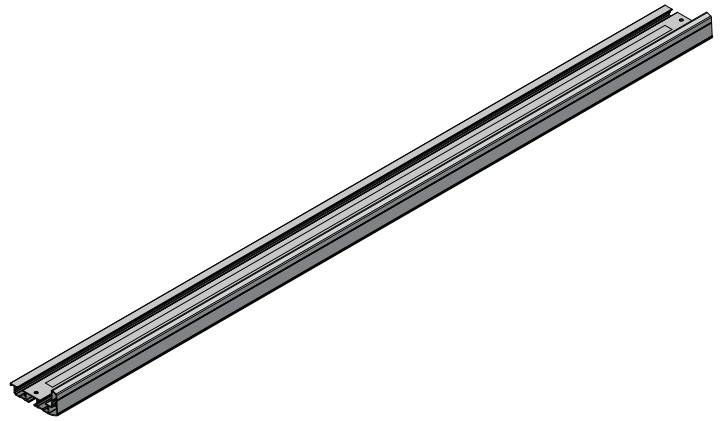
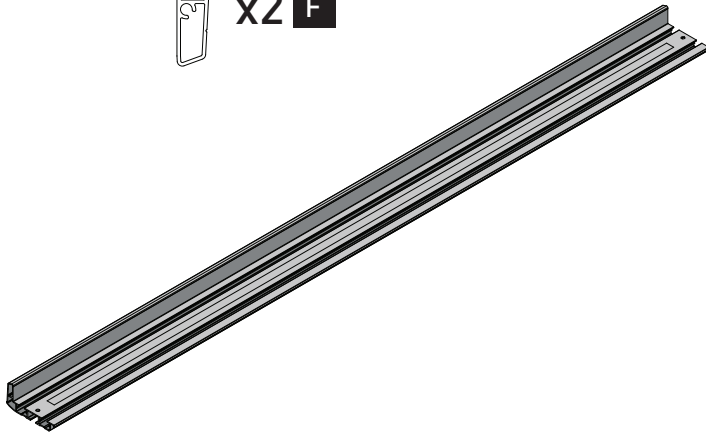
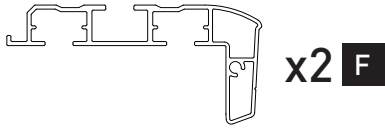

1

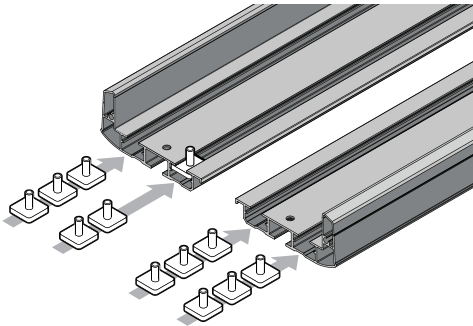
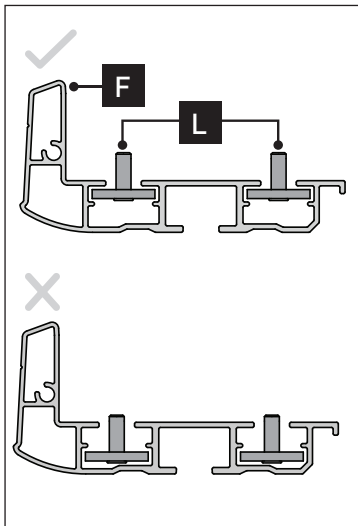

**H** **I**  
x3 = x12

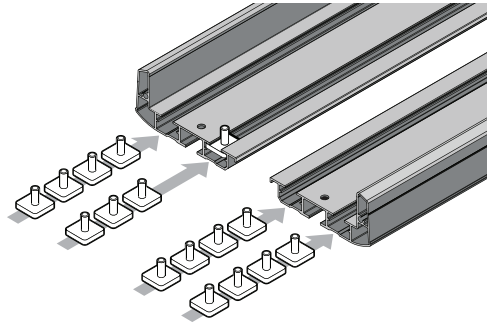

**H** **I**  
x4 = x16

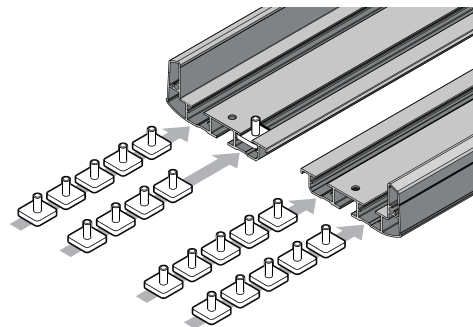

**H** **I**  
x5 = x20

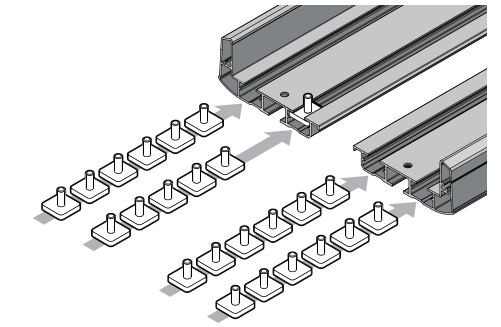

**H** **I**  
x6 = x24

# Instructions

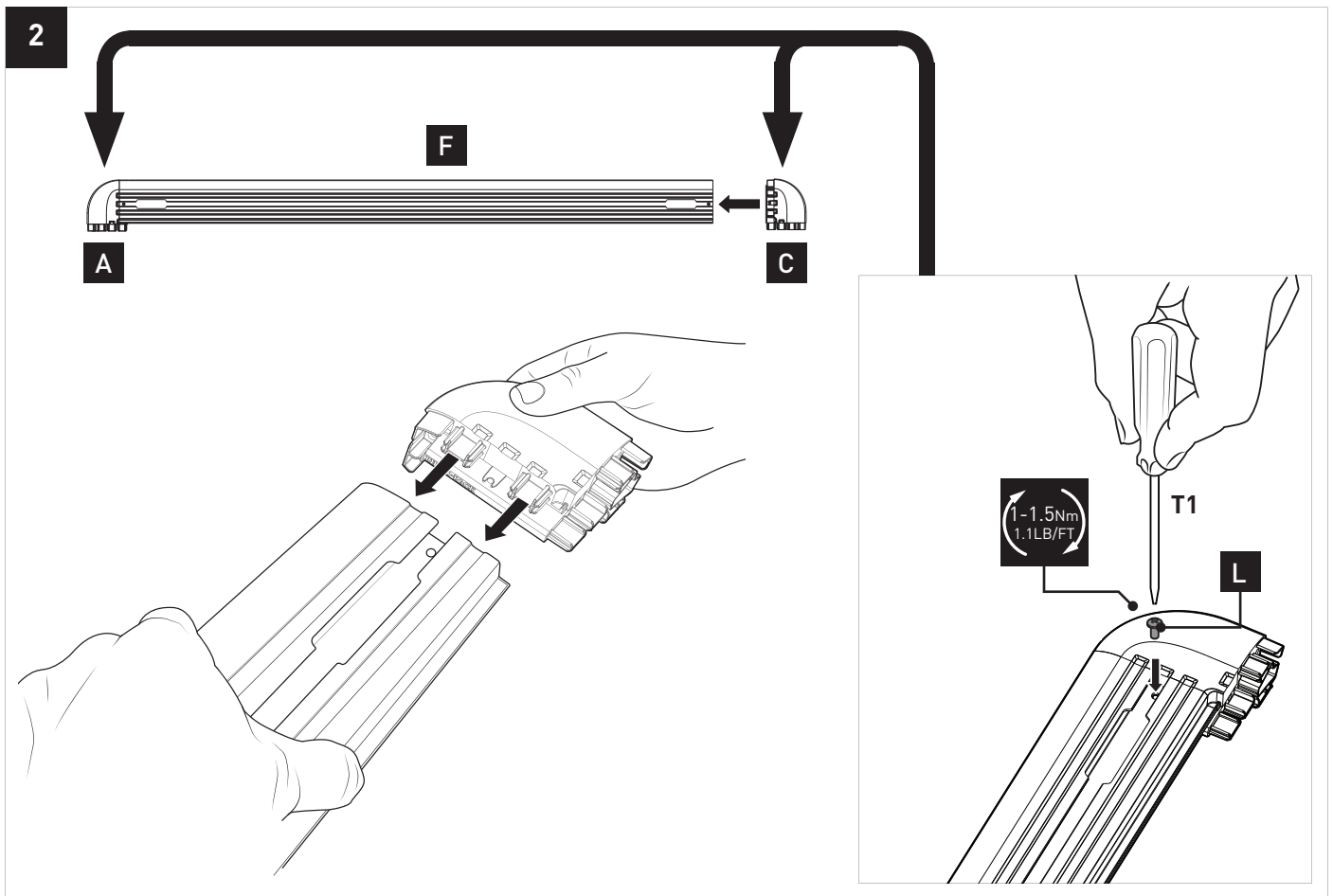

# Instructions

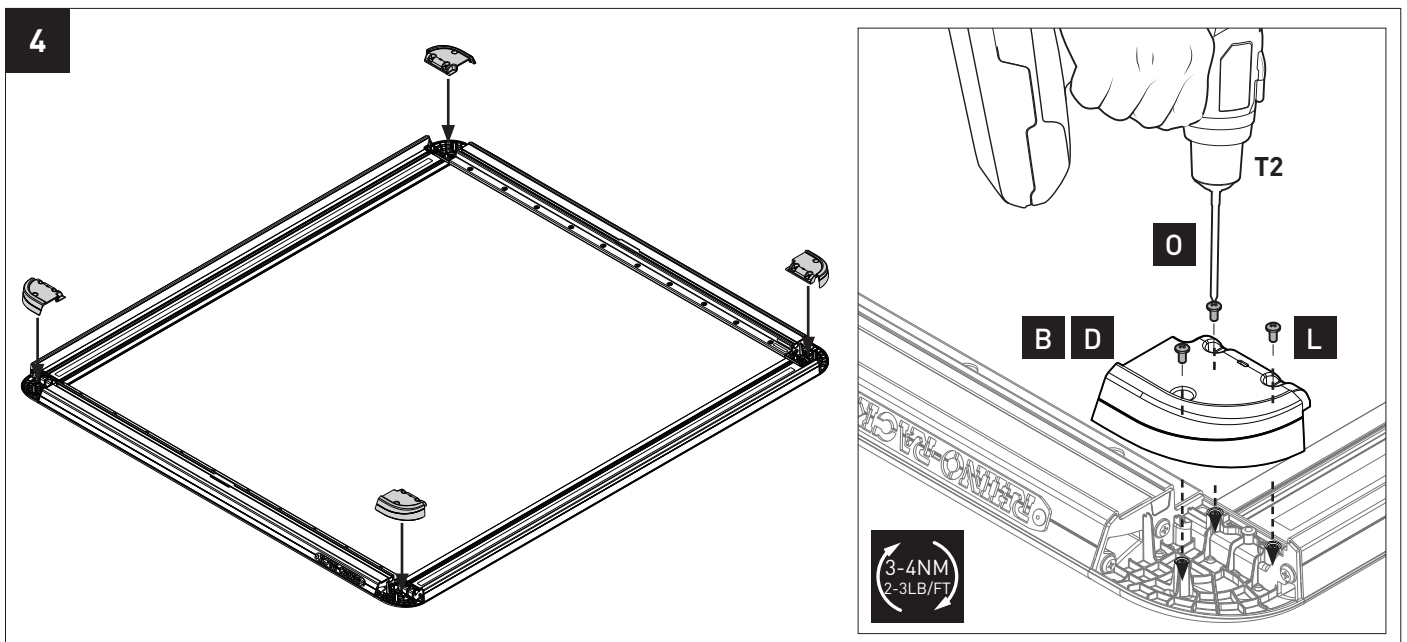
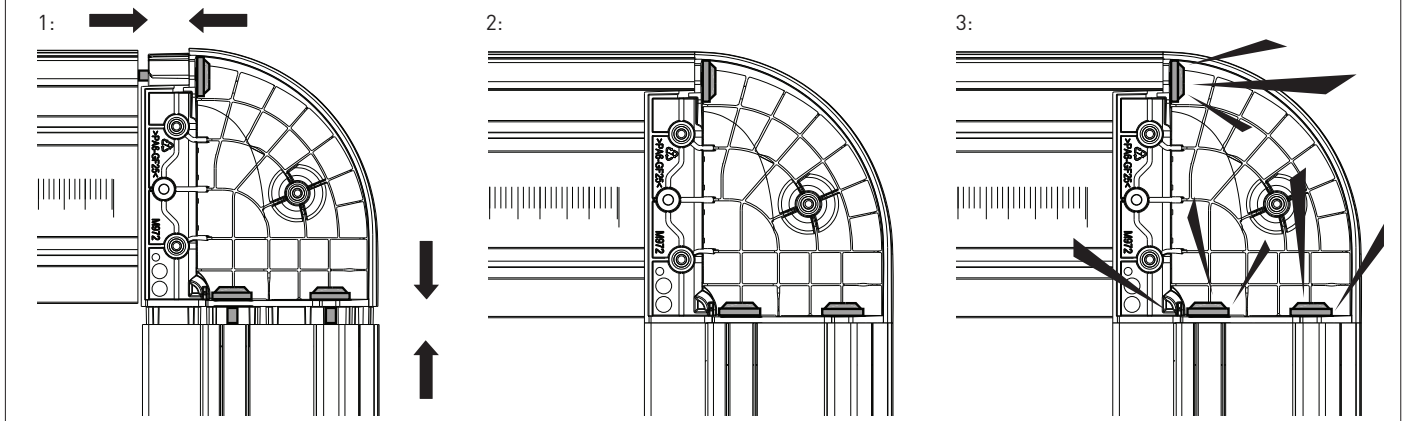
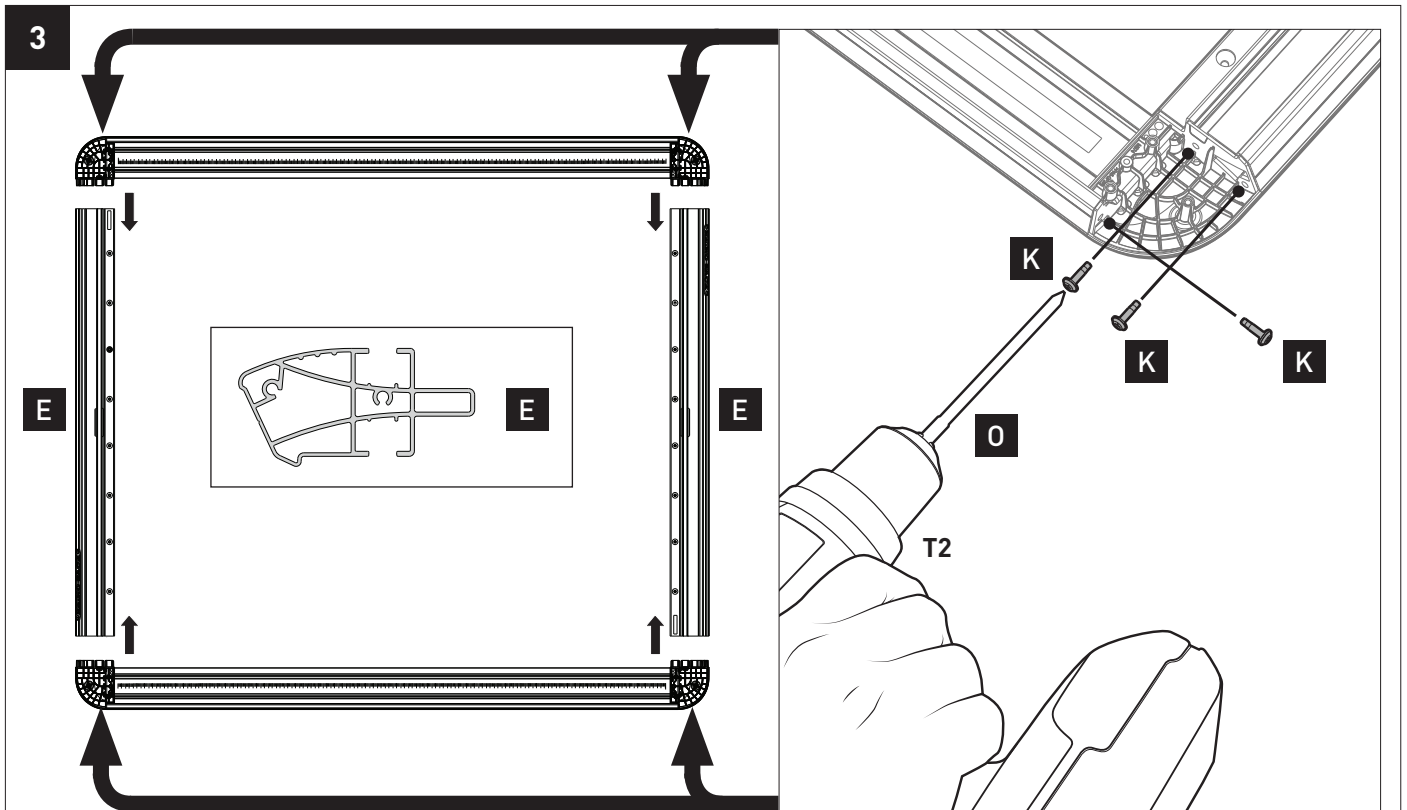

# Instructions

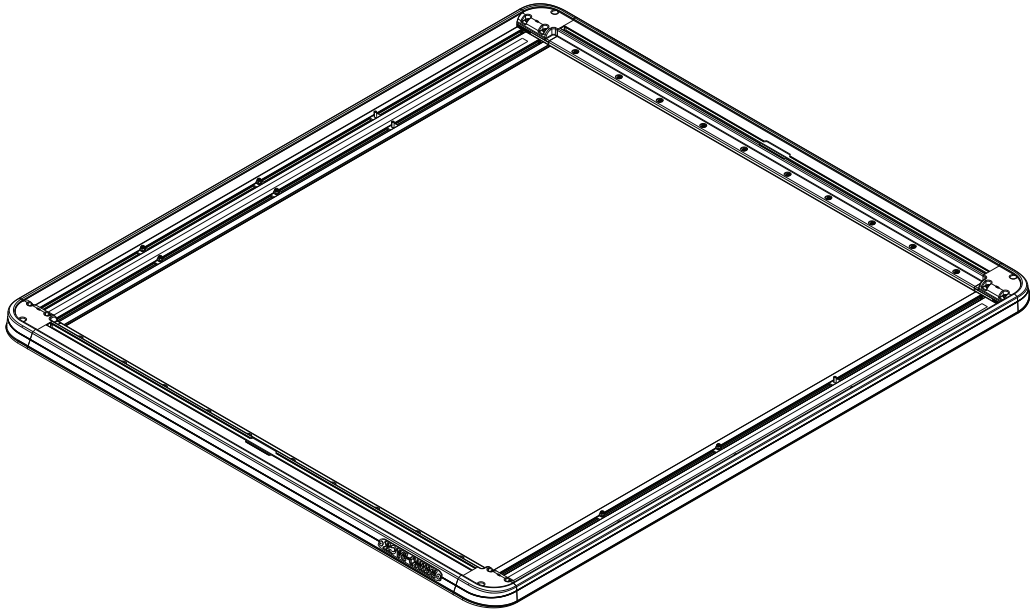

5

<p><b>E</b> x3 + <b>H</b> x10 = <b>I</b> x10</p>	<p><b>E</b> x4 + <b>H</b> x12 = <b>I</b> x12</p>	<p><b>E</b> x5 + <b>H</b> x14 = <b>I</b> x14</p>	<p><b>E</b> x6 + <b>H</b> x16 = <b>I</b> x16</p>

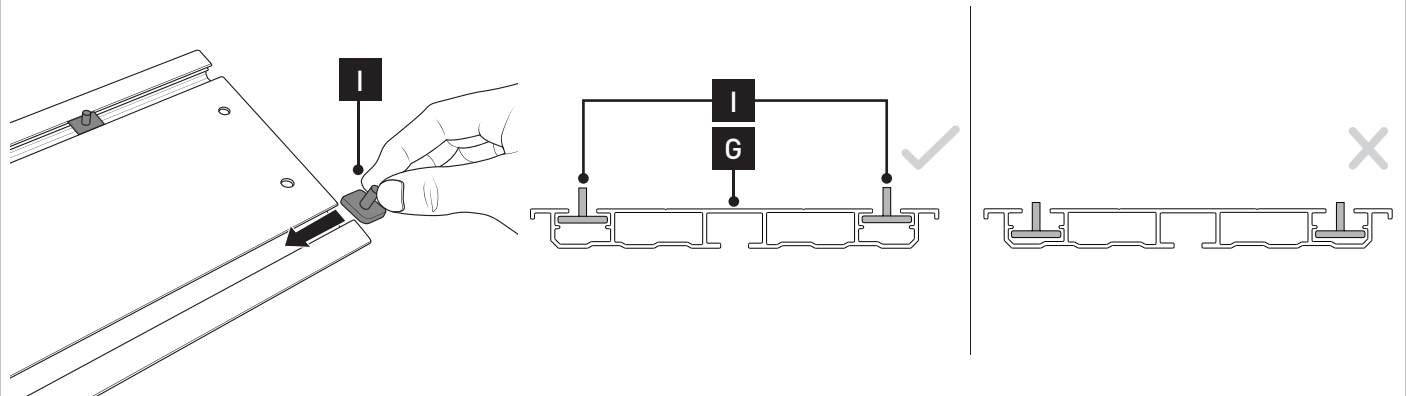

# Instructions

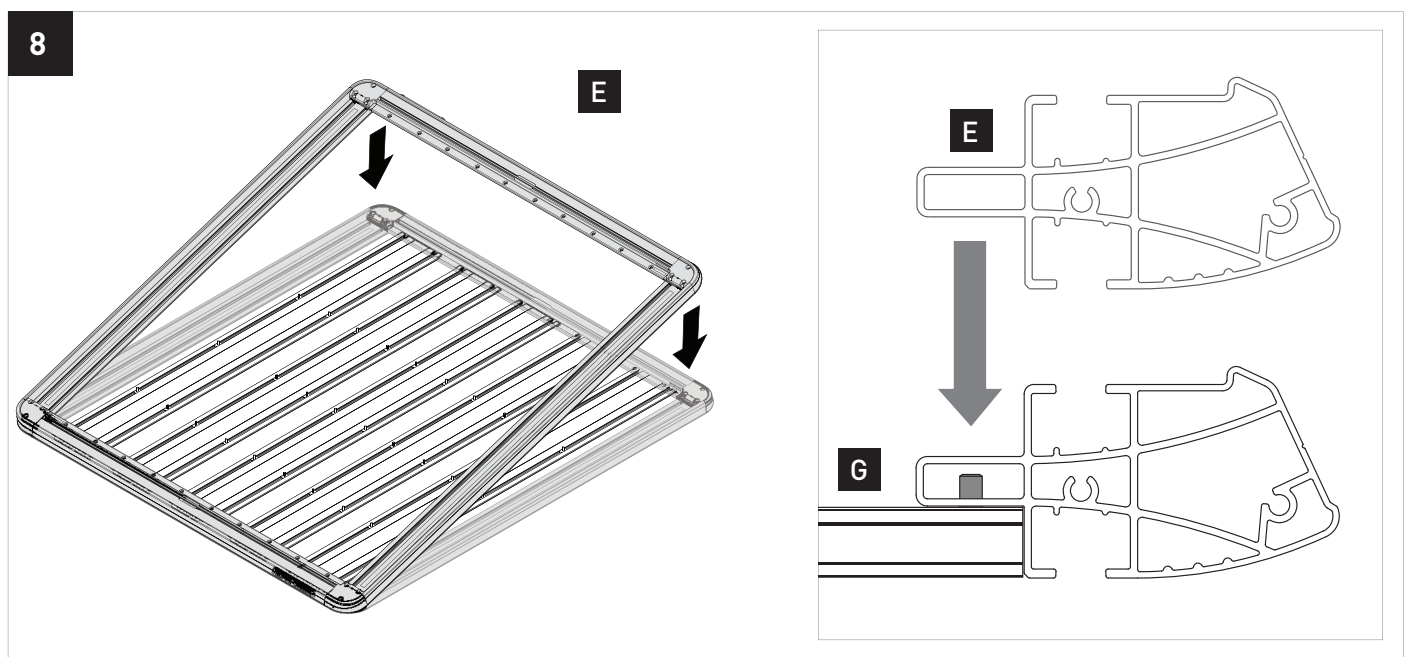
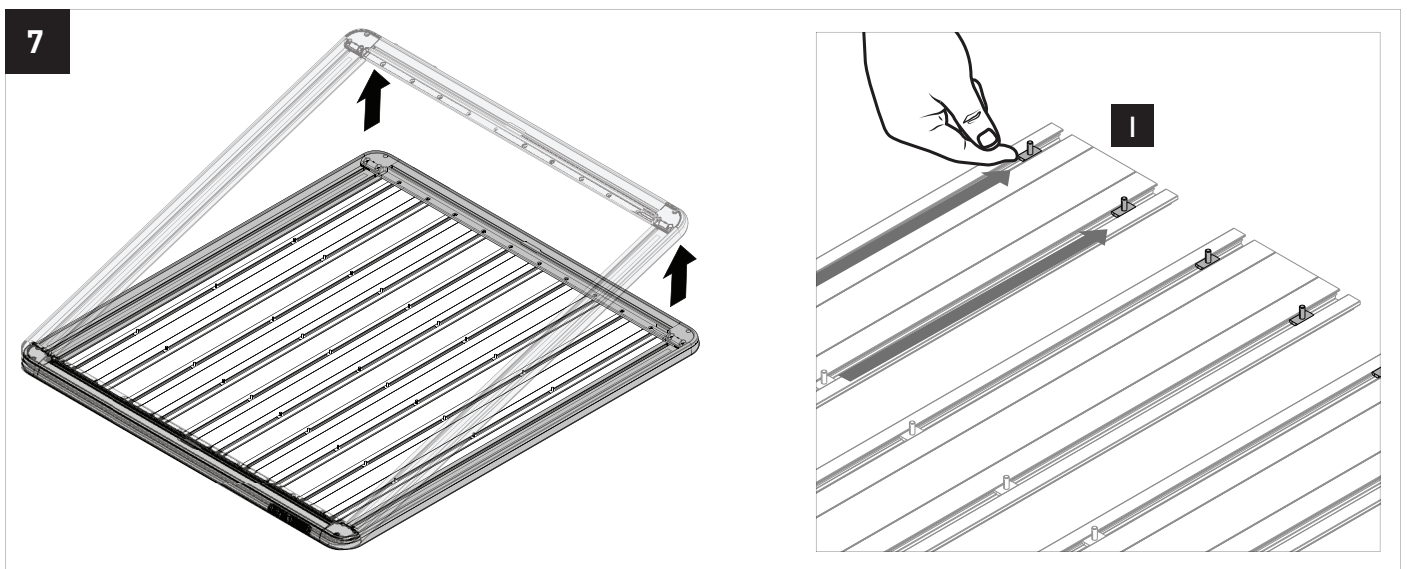
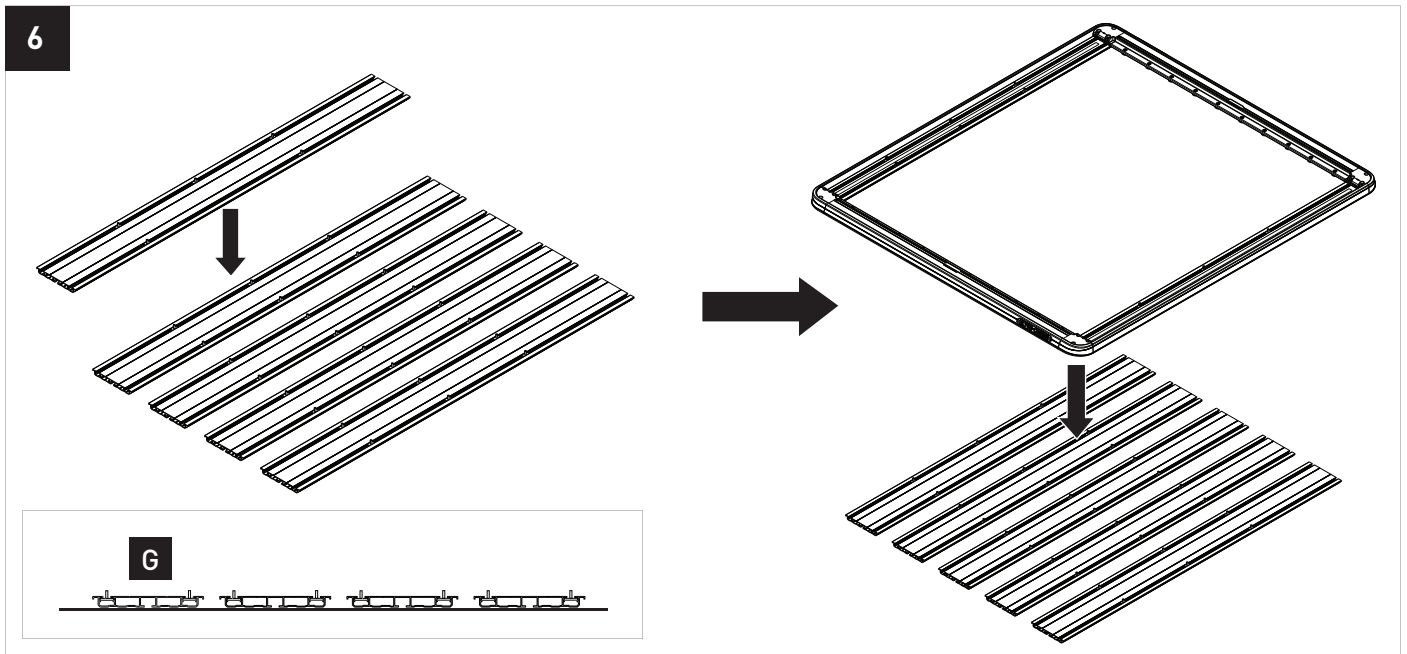



# Instructions

9

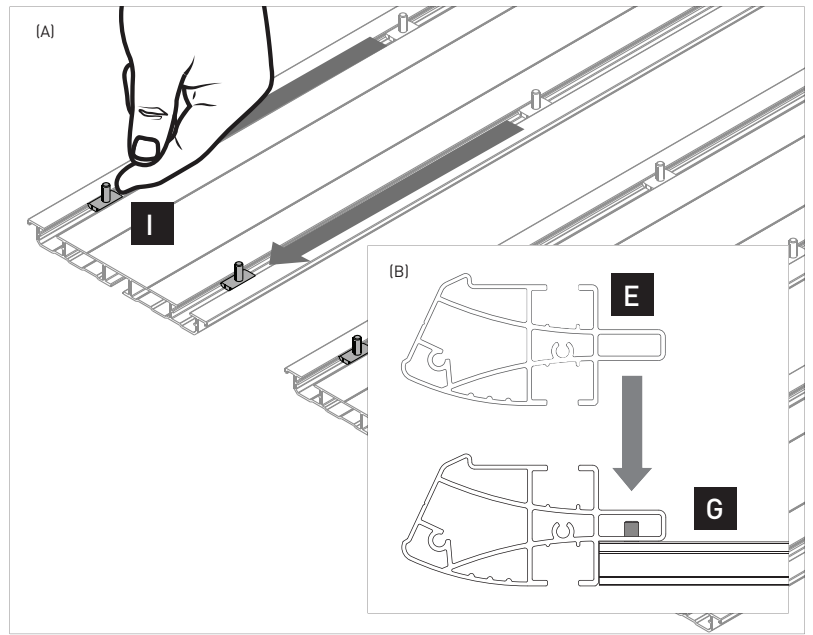
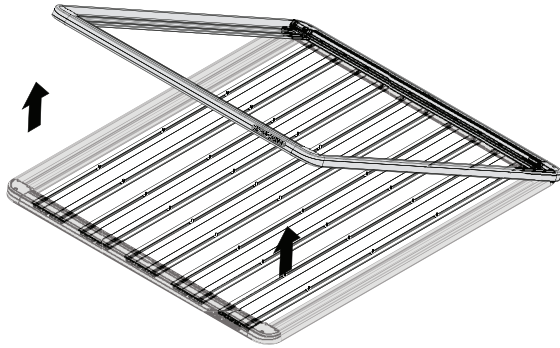

10

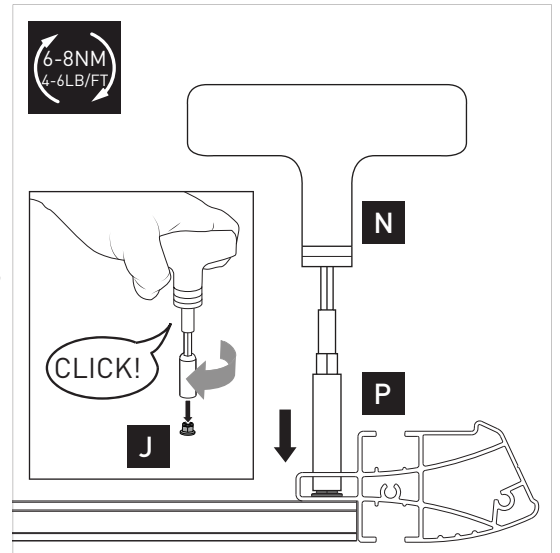
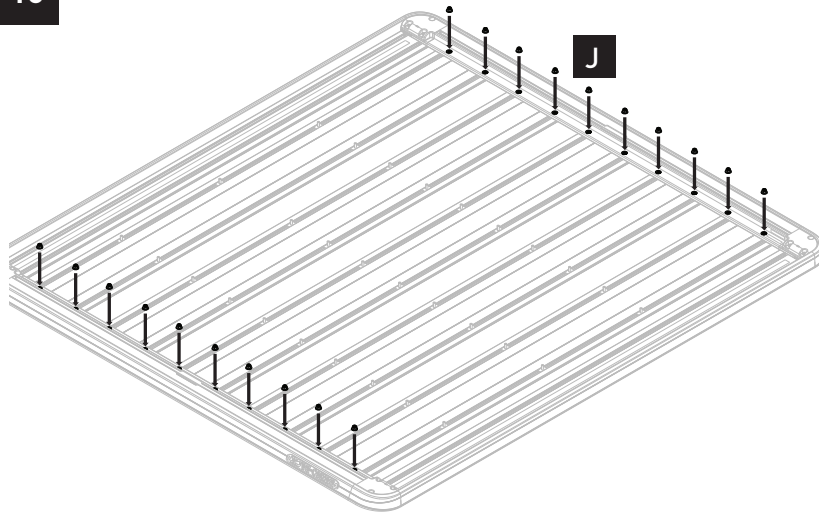

11

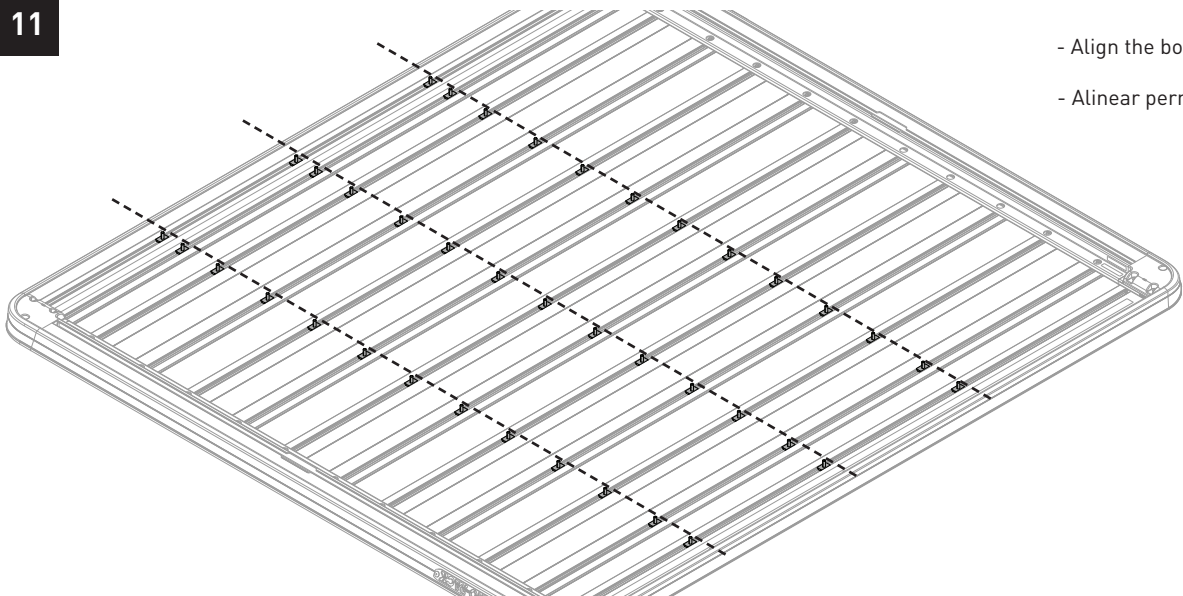

- Align the bolts ( I )
- Alinear perno ( I )

# Instructions

12

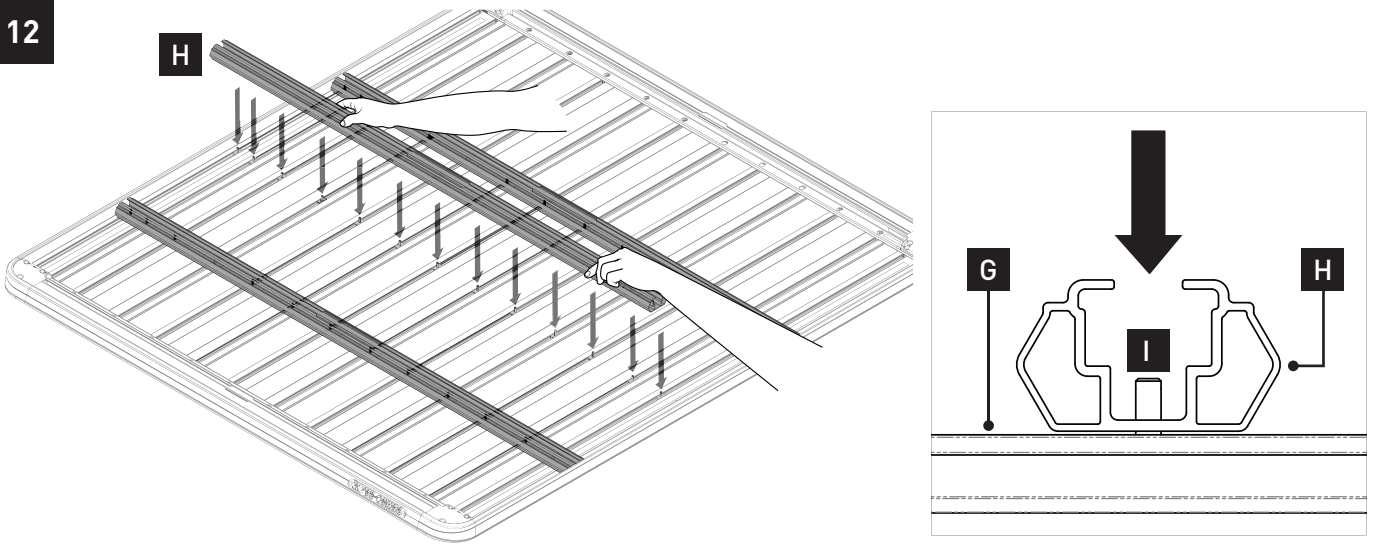

13a

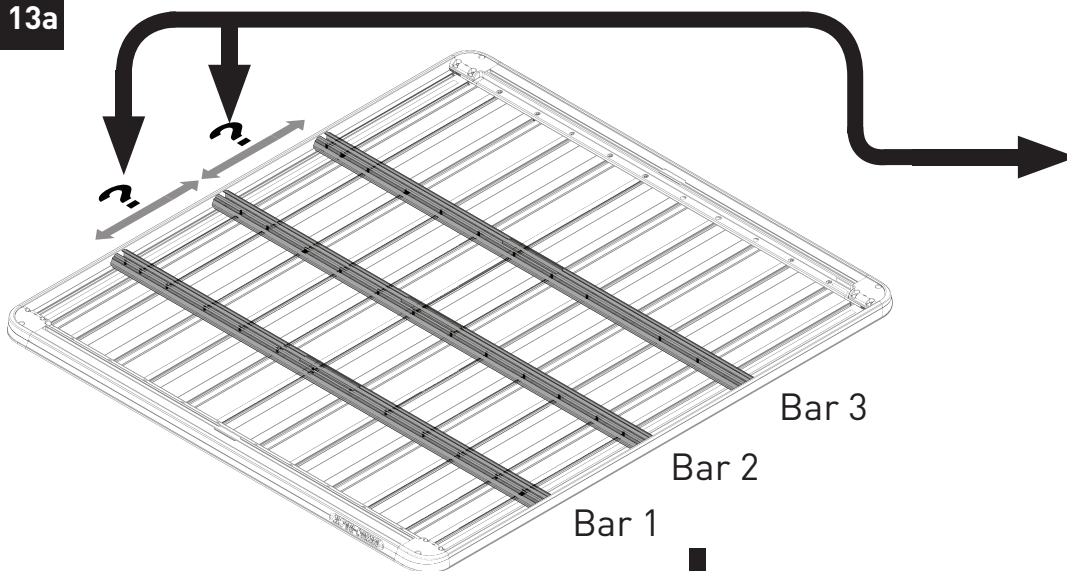

**RHINO-RACK | PIONEER VEHICLE FITTING INFORMATION**

VEHICLE	PIONEER SIZE	CONNECTOR	HEIGHT ADDED (mm / in)
EXAMPLE ONLY	53100	RCL	120.0 / 4.7

**IMPORTANT NOTES** RCP48-BK required. Fixed point factory mount. -

REGION	AUS	NZ	USA	CA	SA	UK	EU	ZA
AVAILABILITY	✓	✓	x	x	x	x	x	x
RUNNING DATES	02/15 -	02/15 -	-	-	-	-	-	-

**UNDERBAR SPACING**

SIZE NO.	A	B	C	D	E	F	G
DIMENSION (CM)	45.2	0	45.2				
SPACERS REQ'D							
CONNECTOR	RCL		RCL				

VEHICLE LOAD LIMIT (VLL) (kg / lbs)	SYSTEM WEIGHT (SW) (kg / lbs)	ON-ROAD CARGO ALLOW. (ORA)	OFF-ROAD CARGO ALLOW. (OFRA)
Up to 100 / 220.5 *	19 (41.2)	OR = VLL - SW	OFRA = OR / 1.5

\*CHECK YOUR VEHICLE OWNERS HANDBOOK FOR VEHICLE MAXIMUM CARRYING CAPACITY. PLEASE ENSURE YOU USE THE VEHICLE MANUFACTURERS MAXIMUM ROOF ALLOWANCE IF IT IS LOWER THAN THE FIGURES LISTED IN THIS INSTRUCTION.

Bar 1, 2, 3

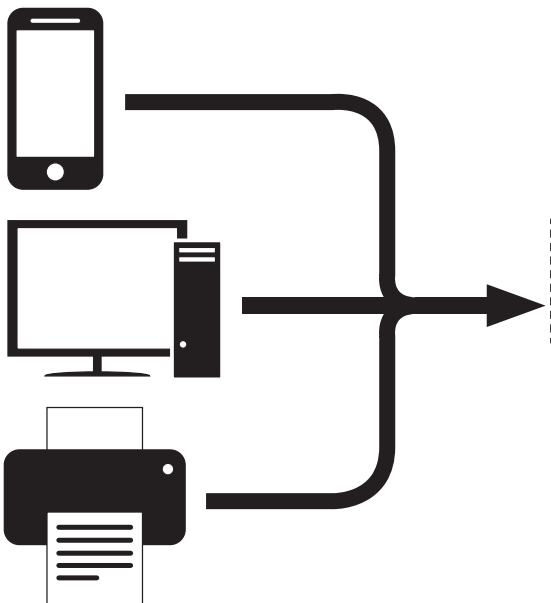

# Instructions

13b

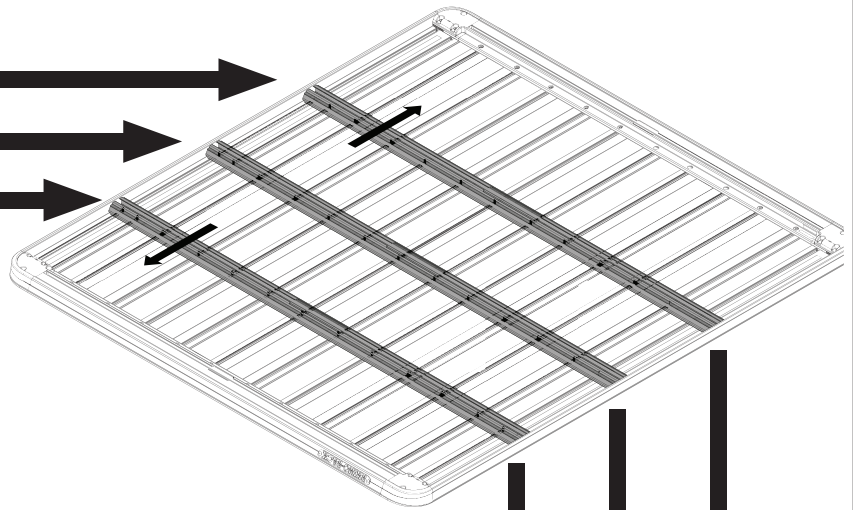

## RHINO-RACK PIONEER VEHICLE FITTING INFORMATION

VEHICLE	PIONEER SIZE	CONNECTOR	HEIGHT ADDED (mm / in)
EXAMPLE ONLY	92100	RCL	120.0 / 4.7

IMPORTANT NOTES: RCP68-BK required. Fixed point factory mount. -

REGION	AUS	NZ	USA	CA	SA	UK	EU	ZA
AVAILABILITY	✓	✓	x	x	x	x	x	x
RUNNING DATES	02/15 -	02/15 -	-	-	-	-	-	-

UNDERBAR SPACING

BAR NO	A	B	C	D	E	F	G
DIMENSION (CM)	45.7	B	45.7				
SPACERS REQ'D							
CONNECTOR	RCL		RCL				

VEHICLE LOAD LIMIT (VLL) (kg / lbs)	SYSTEM WEIGHT (SW) (kg / lbs)	ON-ROAD CARGO ALLOW. (OR) (kg / lbs)	OFF-ROAD CARGO ALLOW. (OFR) (kg / lbs)
Up to 100 / 220.5 *	19 / 41.2	OR = VLL - SW	OFR = OR / 1.5

\*CHECK YOUR VEHICLE OWNERS HANDBOOK FOR VEHICLE MAXIMUM CARRYING CAPACITY. PLEASE ENSURE YOU USE THE VEHICLE MANUFACTURERS MAXIMUM ROOF ALLOWANCE IF IT IS LOWER THAN THE FIGURE LISTED IN THIS INSTRUCTION.

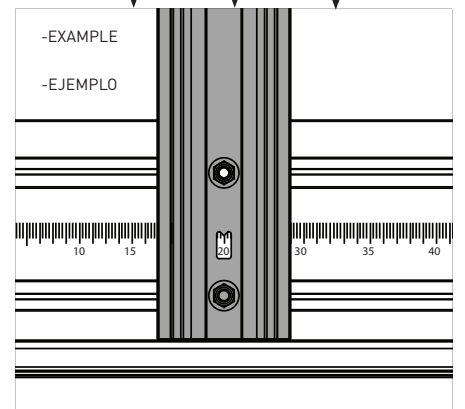

14

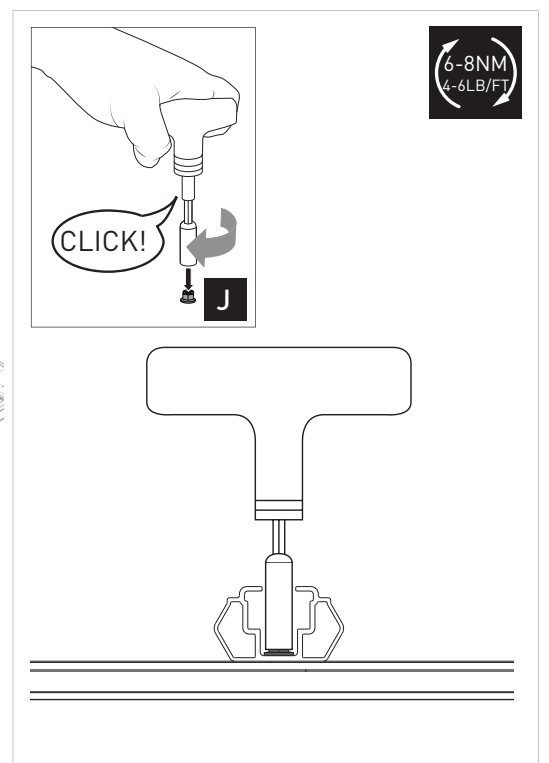
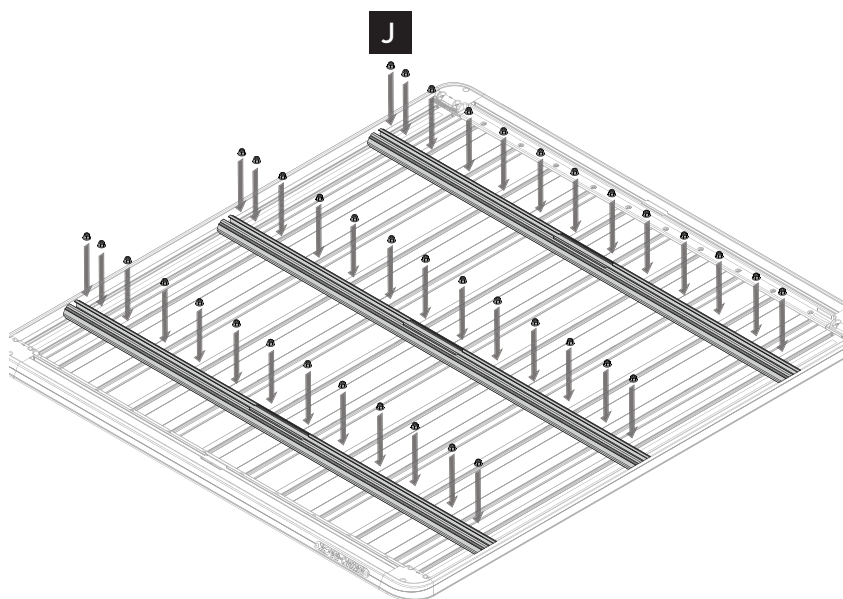

# Instructions

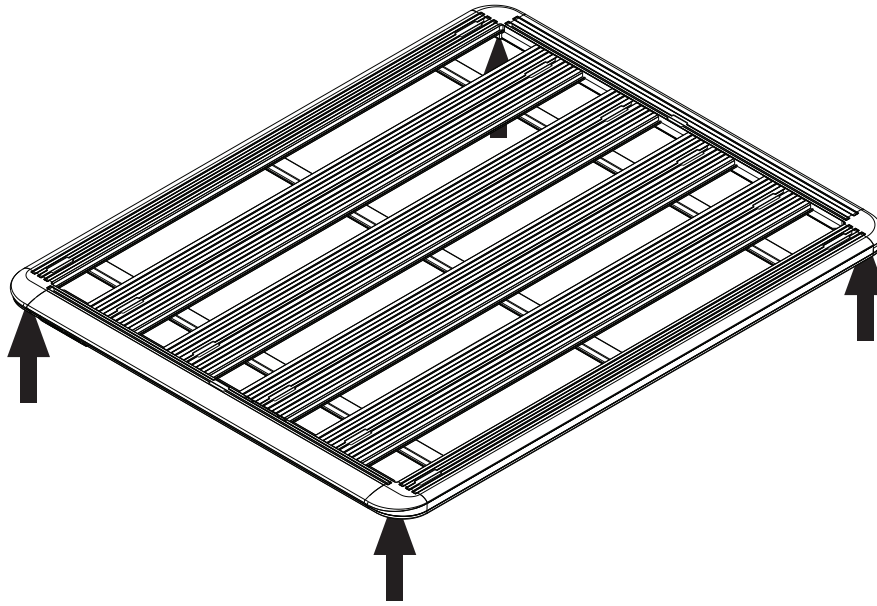

**Note** - For Wiring

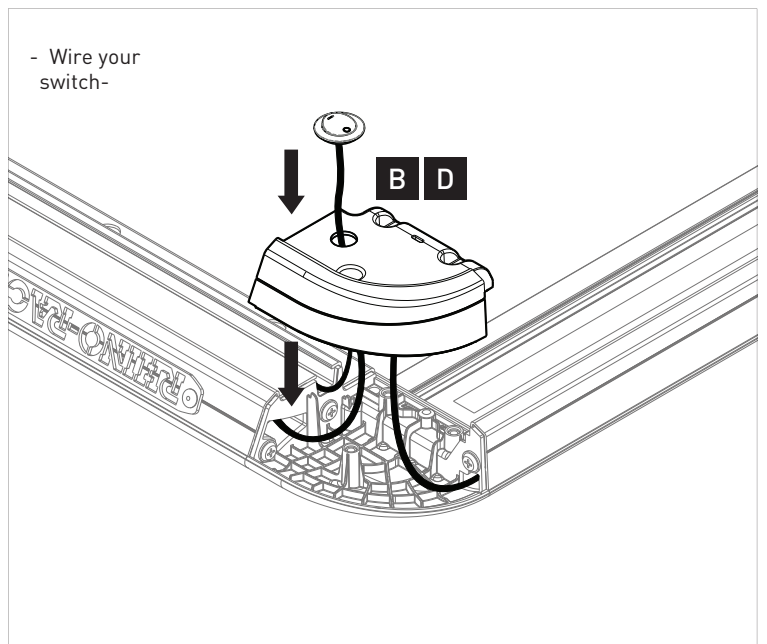
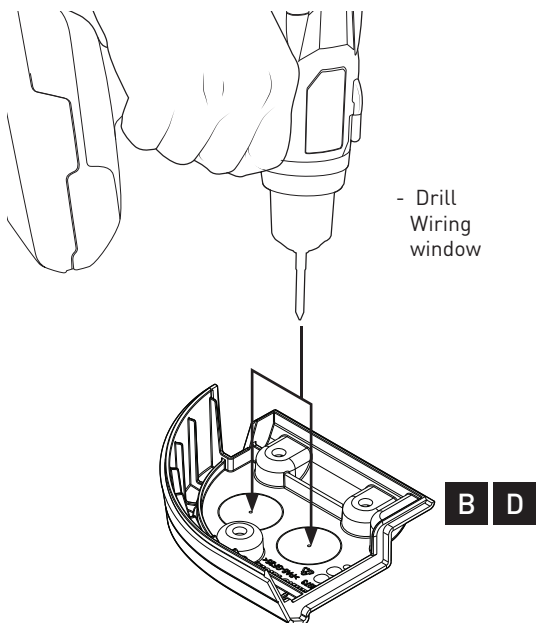
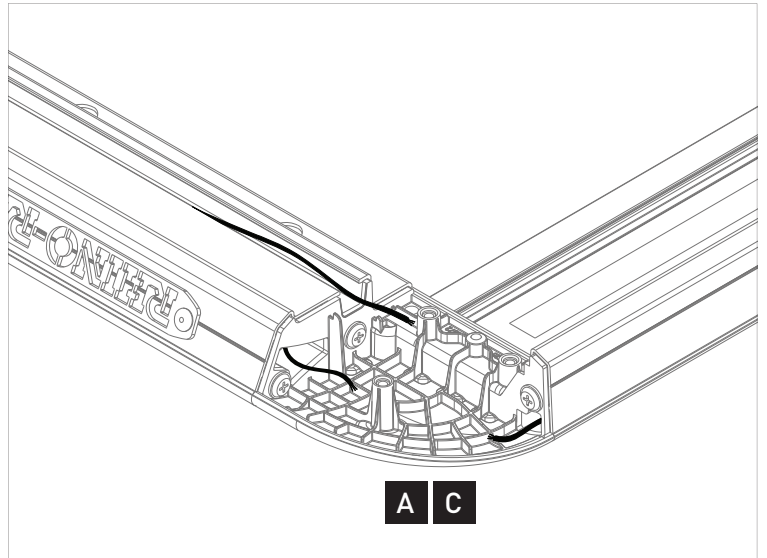
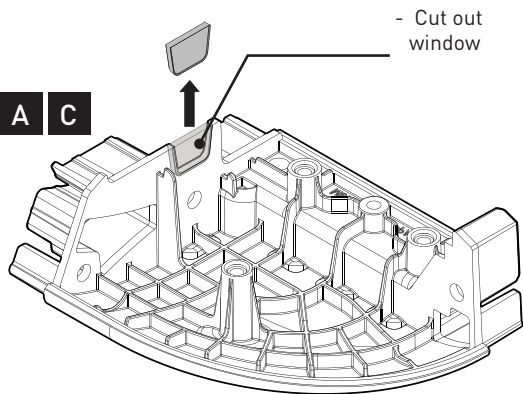

# Instructions

**15** RLT600, RCL/RCH,  
RL leg variants.

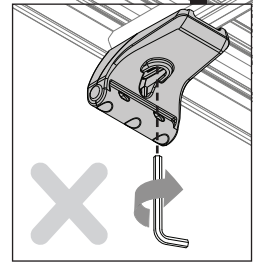
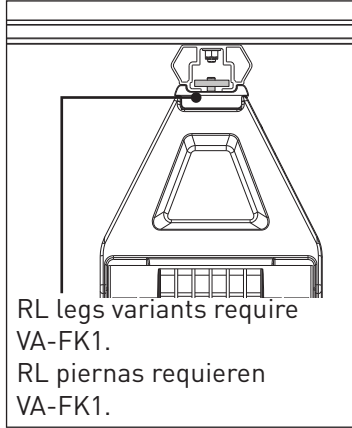
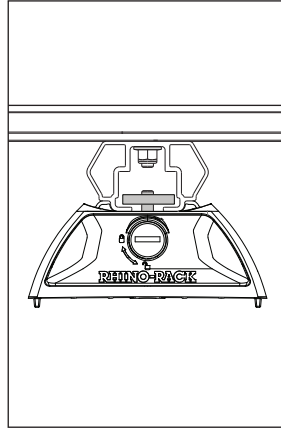
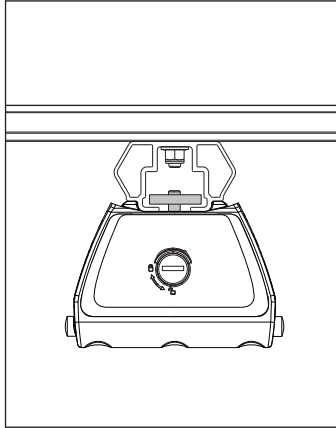
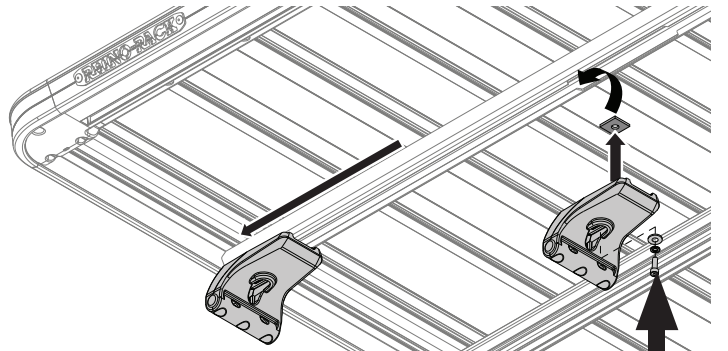
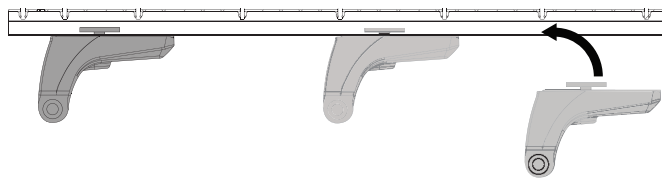

**16** SXB

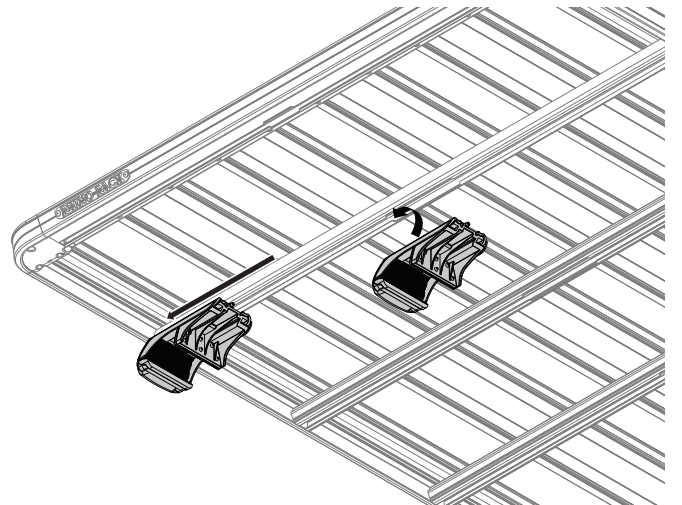
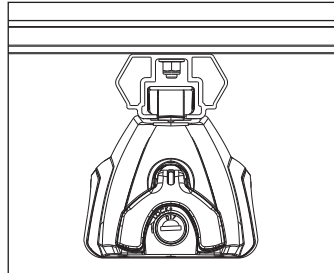
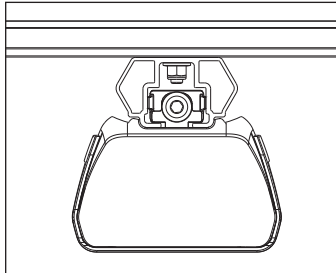
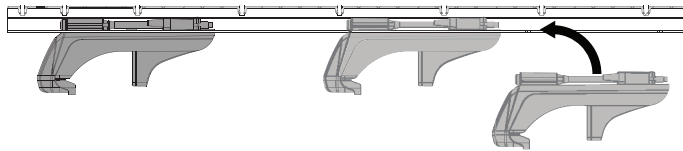

**17**

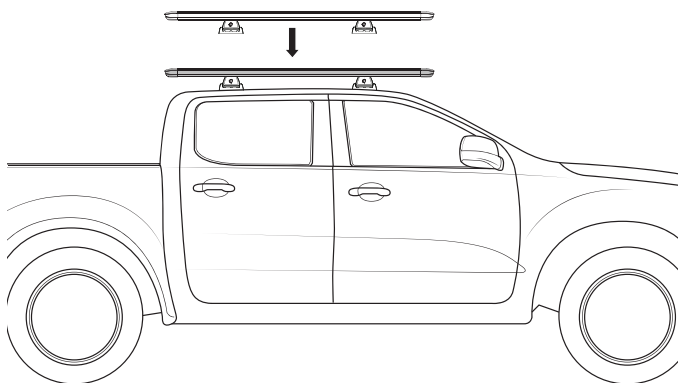

**18**

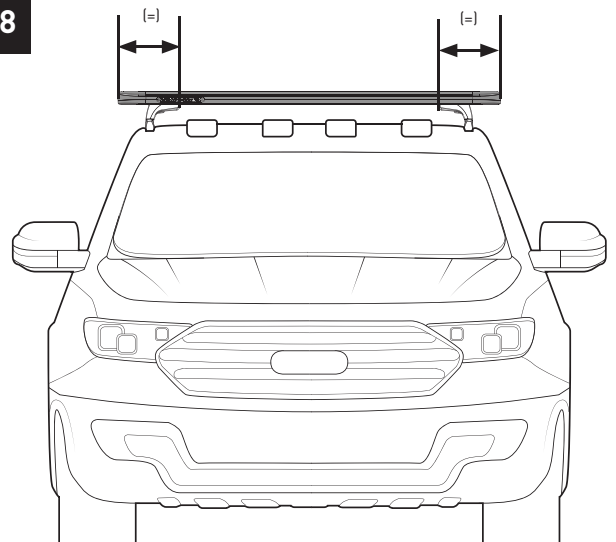

# Instructions

19

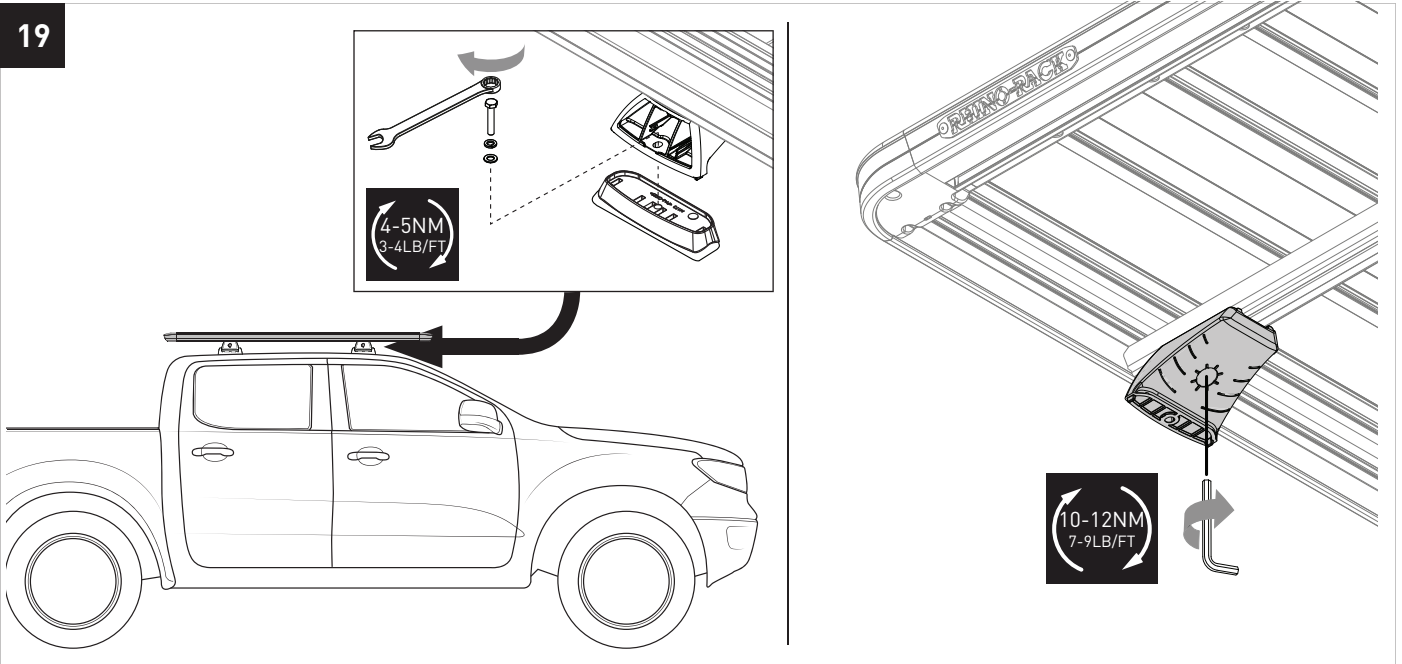

20 Backbone

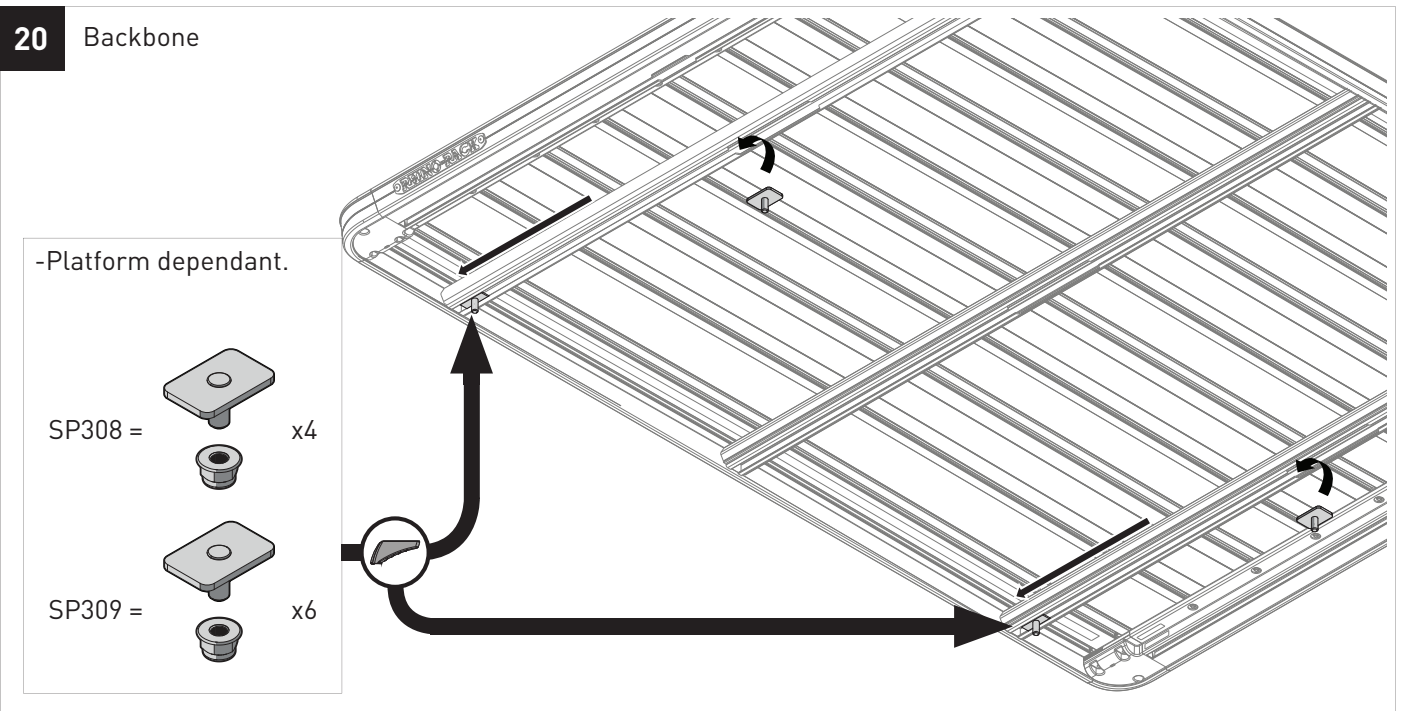

21

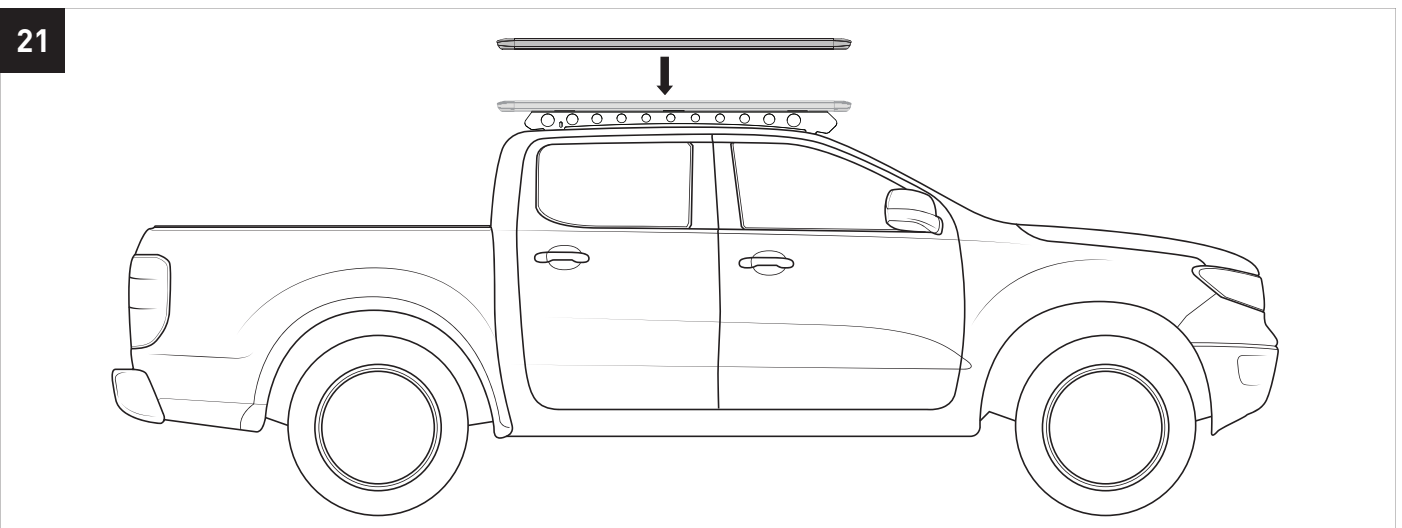

22

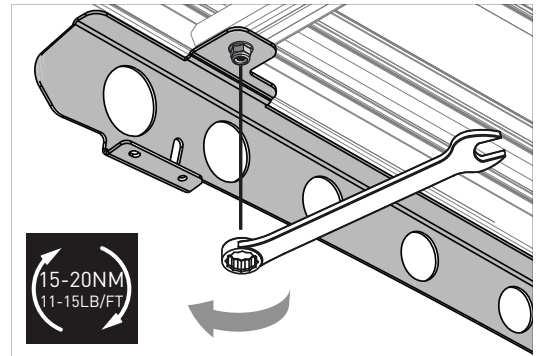
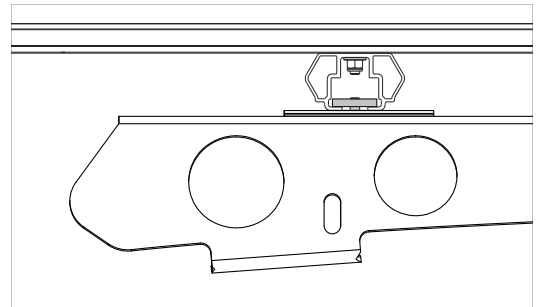
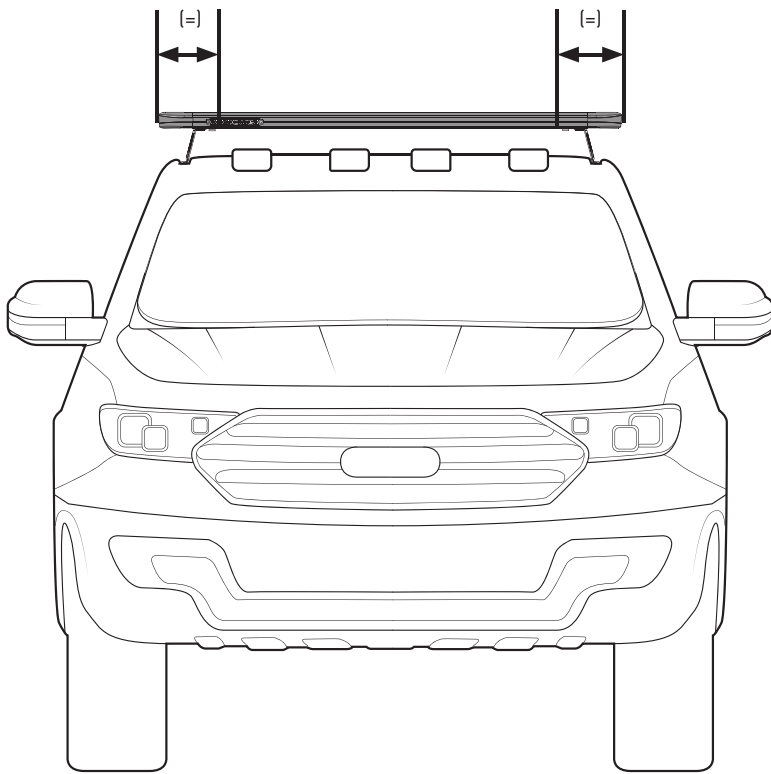

Note

**RHINO-RACK**  
PIONEER ALLOY TRAY (assembled)

**Important:**

1. Always use proper tie-down technique to secure your load.
2. Always use proper tie-down technique to secure your load.
3. Always use proper tie-down technique to secure your load.
4. Always use proper tie-down technique to secure your load.

© 2018 Rhino-Rack, Inc.

**RHINO-RACK | PIONEER VEHICLE FITTING INFORMATION**

Vehicle	Year	Model	Tray Part #
Subaru	2013-2014	Outback	RT100
Subaru	2013-2014	Forester	RT100
Subaru	2013-2014	XV	RT100
Subaru	2015-2016	Outback	RT100
Subaru	2015-2016	Forester	RT100
Subaru	2015-2016	XV	RT100
Subaru	2017-2018	Outback	RT100
Subaru	2017-2018	Forester	RT100
Subaru	2017-2018	XV	RT100

**WEATHER PROTECTION**

Vehicle	Year	Model	Tray Part #
Subaru	2013-2014	Outback	RT100
Subaru	2013-2014	Forester	RT100
Subaru	2013-2014	XV	RT100
Subaru	2015-2016	Outback	RT100
Subaru	2015-2016	Forester	RT100
Subaru	2015-2016	XV	RT100
Subaru	2017-2018	Outback	RT100
Subaru	2017-2018	Forester	RT100
Subaru	2017-2018	XV	RT100

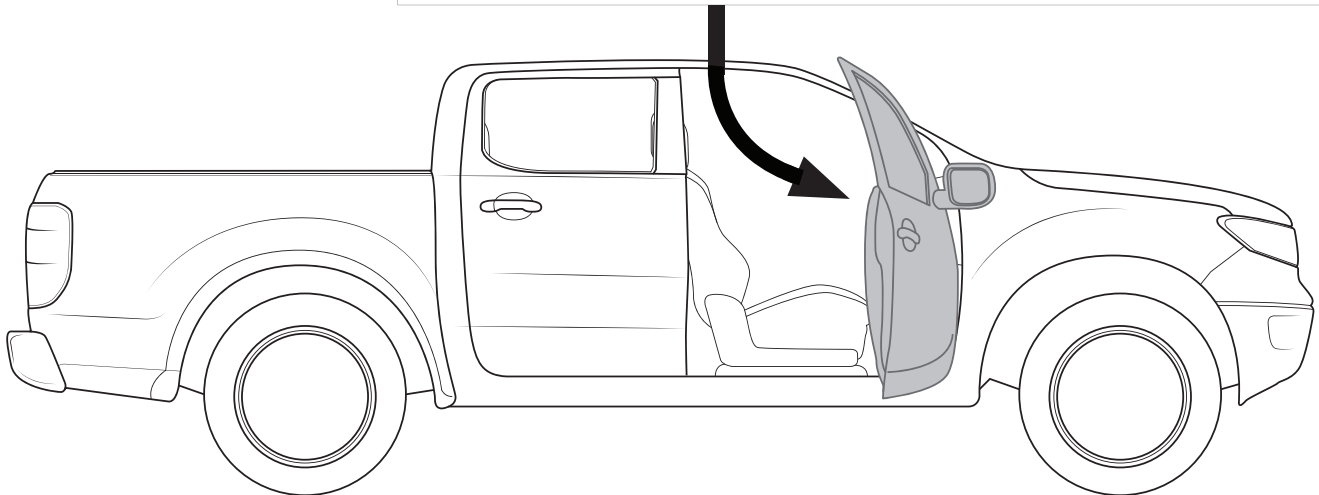



# RHINO-RACK®

## BASE KIT - RCP75-BK

**Important:**

1. Check the Rhino-Rack website to ensure you have the latest issue of these instructions.
2. Please refer to your fitting instruction to ensure that the roof racks are installed in the correct locations.
3. Check the contents of kit before commencing fitment and report any discrepancies.
4. Place these instructions in the vehicle's glove box after installation is complete.
5. These instructions must be followed for warranty to be upheld.

**Fit Time:** 1 hour

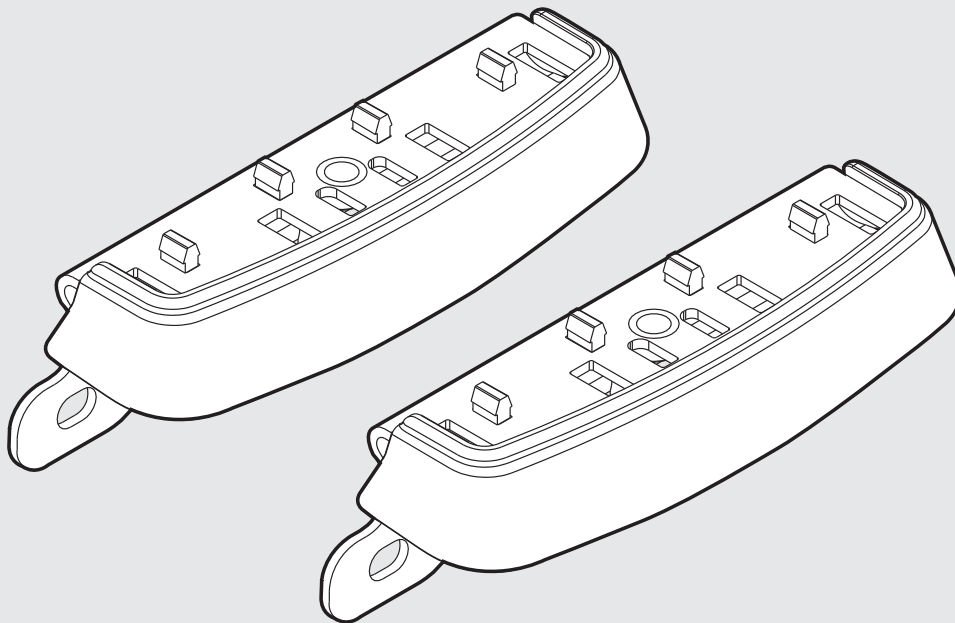



## RCP75-BK Instructions

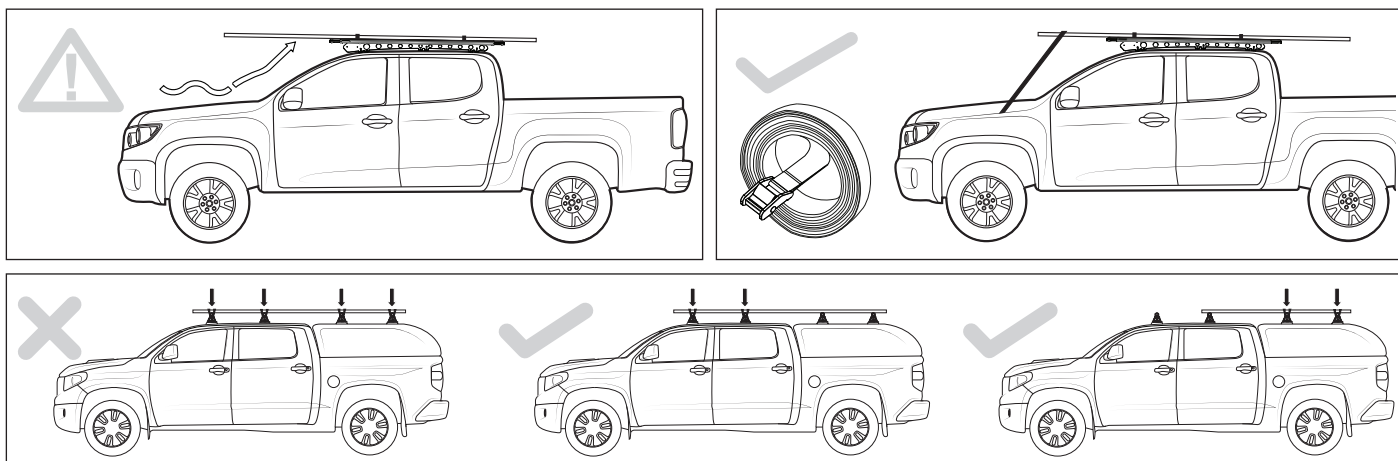

ON ROAD CARGO ALLOWANCE (R)	OFF ROAD CARGO ALLOWANCE (OR)	VEHICLE ROOF LOAD LIMIT (VLL)	SYSTEM WEIGHT (SW)
$(VLL) - (5\text{kg}/11\text{lbs}) = \text{xxkg}/\text{xxlbs}$	$(R)/1.5 = (OR)$	$\text{XXkg} / \text{XXlb}$ (CHECK VEHICLE OWNERS HANDBOOK FOR SPECIFIC FIGURE).	5kg/11lbs

### Carrying Capacity

Check your vehicle owners hand book for vehicle maximum carrying capacity. Please ensure you use the vehicle manufactures maximum roof allowance if it is lower than the figure listed in this instruction.

Load must be evenly distributed over the system.

**Off Road:** Any driven path taken that does not contain a surface protection layer (tar/bitumen).

**Vehicle Load Limit:** Total permissible weight attached to the roof of the car. This is inclusive of the weight of the roof rack system.

**System Load Limit:** Total permissible weight allowed on top, and attached to roof racks whilst the vehicle is in motion.

**Static Allowance:** Total permissible weight allowed on top, and attached to roof racks whilst the vehicle is stationary.

### Torque Settings

Unless stated otherwise in these instructions, all fasteners should be set to the following torque settings - M6: 4-5Nm (3-4lbs/ft), M8: 8-10Nm (6-7.5lbs/ft) and M10: 16-18Nm (12-13lbs/ft).

### Warning

- Check part number or kit is correct for use with your vehicle.
- Do not attempt to fit the rack system to your vehicle unless you fully understand these fitting instructions. Please direct any questions regarding fitting to the dealer from where the roof racks were purchased.
- Although the system is tested and approved to AS1235-2000 / ISO 11154, off-road conditions can be much more rigorous. Extreme care must be taken in off road conditions.
- Roof racks must be removed when vehicle is put through an automatic car wash.
- With utility vehicles, the cabin and the canopy move independently. Roof racks and vehicle can be damaged if the item transported is rigidly fixed at points on both the cabin and canopy. Instead, rigidly fix to either the cabin roof racks or the canopy roof racks.
- Always ensure you fasten your load securely.
- Use only non-stretch fastening ropes or straps to attach cargo to your load.

### In service maintenance checks

- All bolt connections should be checked after driving a short distance when you first install your roof racks.
- All bolted connections should be checked again at regular intervals (weekly is recommended, depending on road conditions, usage, loads and distances travelled).
- All bolted connections should be checked each time they are re-fitted.







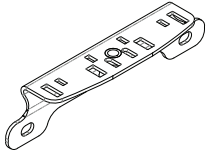
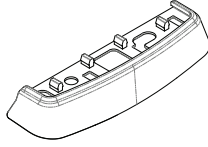

### Note for Dealers and Fitters

It is your responsibility to ensure these fitting instructions are given to the end user or client. These instructions remain the property of Rhino-Rack Australia Pty. Ltd. and may not be used or changed for any other purpose than intended.

# RCP75-BK Instructions

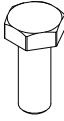
---

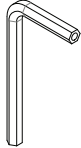
## Parts List

<p>RCP Bracket</p>  <p><b>A</b> x4</p>	<p>Rubber Skirt</p>  <p><b>B</b> x4</p>	<p>M6 x 16mm Cap Screw</p>  <p><b>C</b> x8</p>	<p>M6 Spring Washer</p>  <p><b>D</b> x12</p>
<p>M6 x 12.5mm Flat Washer</p>  <p><b>E</b> x8</p>	<p>M6 x 16mm Hex Bolt</p>  <p><b>F</b> x4</p>	<p>M6 x 16 Flat Washer</p>  <p><b>G</b> x4</p>	<p>5mm Sec Allen Key</p>  <p><b>H</b> x1</p>
<p>Instructions</p>  <p><b>I</b> x1</p>			

1

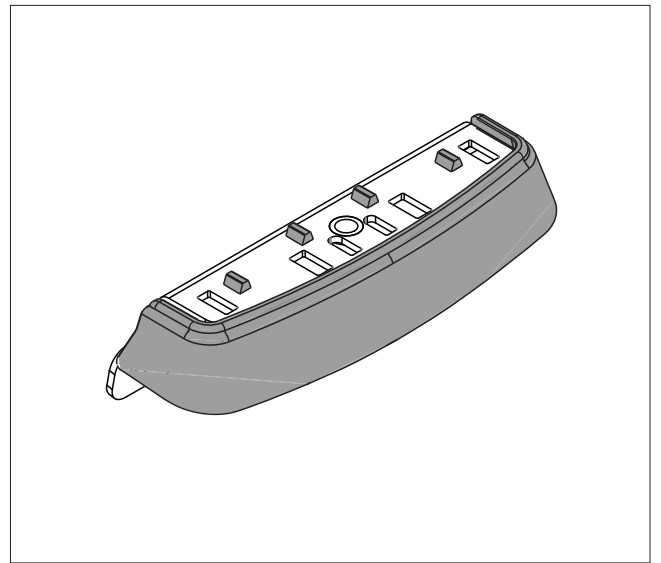
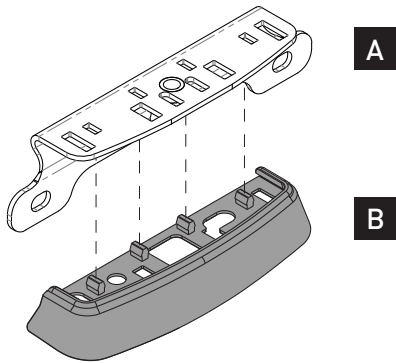

2

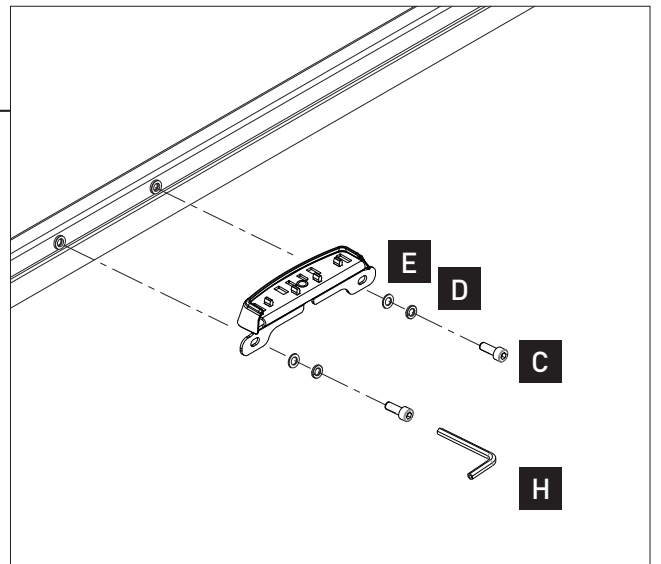
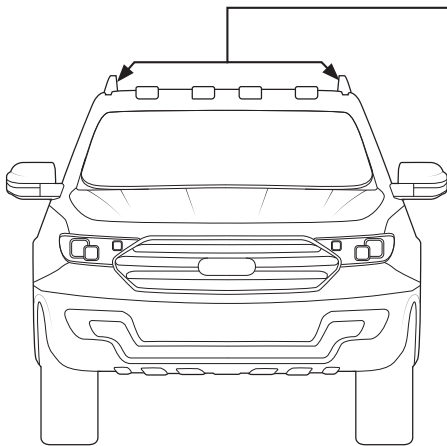

**FOR MOUNTING LEGS:**

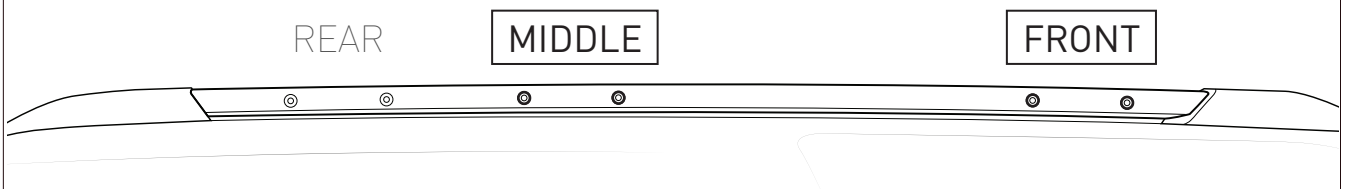

**FOR MOUNTING PIONEER PLATFORMS:**

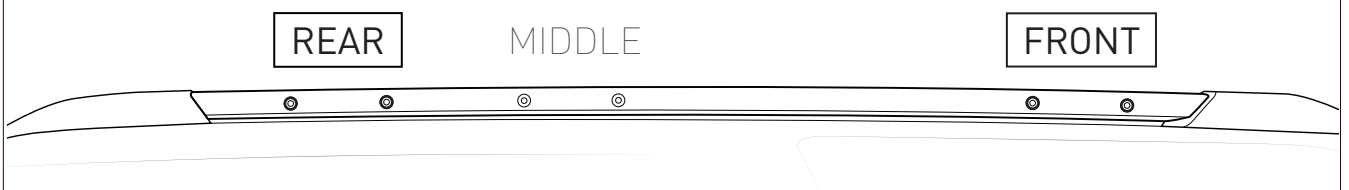

3

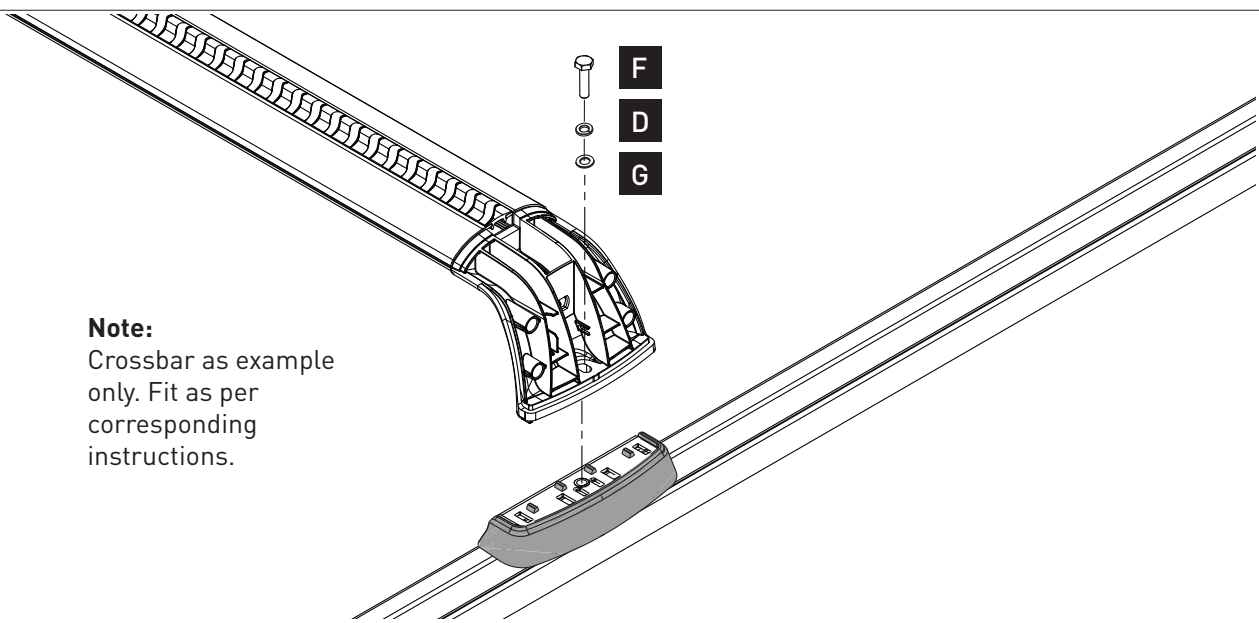

**Note:**  
Crossbar as example  
only. Fit as per  
corresponding  
instructions.



# RHINO-RACK

## RCL, RCH 2,4,6 Kits

**Important:** Please read these instructions carefully prior to installation. Please refer to your fitting instruction to ensure that the Roof Rack System is installed in the correct location. Check the contents of kit before commencing fitment and report any discrepancies. Place these instructions in the vehicle's glove box after installation is complete.

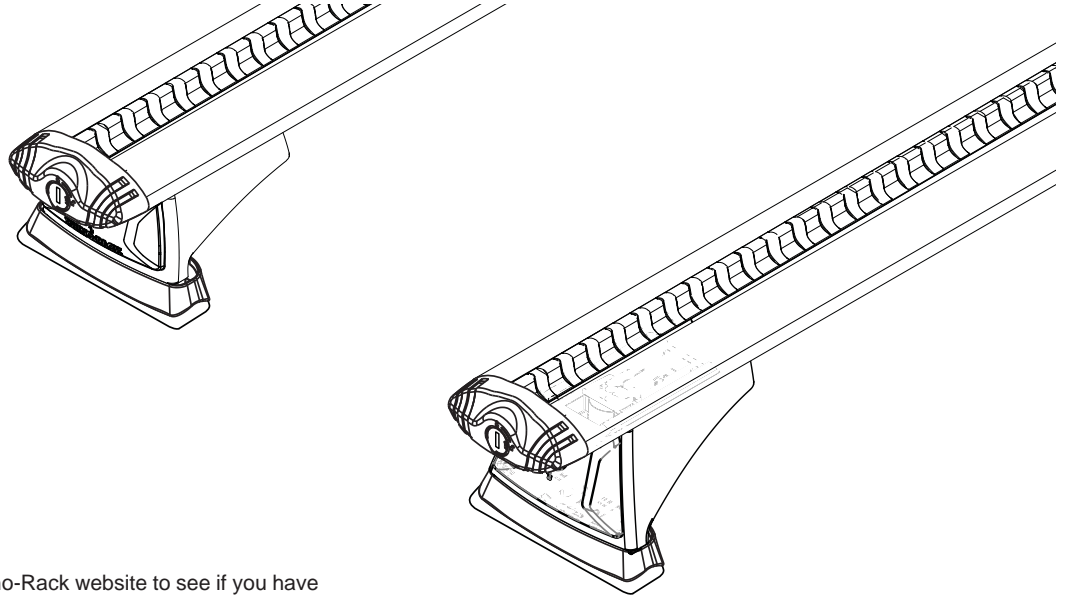

**Note:** Be sure to check Rhino-Rack website to see if you have the latest version of instructions before beginning installation.

**Maximum load carrying capacity: 100kg / 220lbs**

### Important Information

1.  Check Part No./Kit is correct
2.  Read through instruction before installing
3.  Fit roof rack accessory
4.  Check and recheck all fasteners are secure

**Maximum carrying capacity: Up to 100kg (220lbs)** including the weight of the rack system.

Please refer to your vehicle manufacturers handbook for maximum carrying capacity. Always use the lower of the two figures. Load must be evenly distributed over the entire basket.

**Warning:** Do not attempt to fit the rack system to your vehicle unless you fully understand these fitting instructions. Please direct any questions regarding fitting to the dealer from where the roof racks were purchased.

**Use only non-stretch fastening ropes or straps.**

**Recommendations:** It is essential that all bolt connections be checked after driving a short distance when you first install your roof racks. Bolt connections should be checked again at regular intervals (once a week is enough, depending on road conditions, usage, loads and distances travelled). You should also check the roof racks each time they are re-fitted. Always make sure to fasten your load securely. Please also ensure that all loads are evenly distributed and that the centre of gravity is kept as low as possible and must be entirely contained within the extents of the roof racks. **Rack System must be removed when putting vehicle through an automatic car wash.**

**Caution:** The handling characteristics of the vehicle changes when you transport a load on the roof. For safety reasons we recommend you exercise extreme care when transporting wind-resistant loads. Special consideration must be taken into account when cornering and braking.

**Off-road use:**

The Roof Rack System may be used in off road applications, however a safety factor of 1.5 is enforced. That is, maximum permissible off road load is **66kg (145lbs)**. Although the crossbars are tested and approved to AS1235-2000/ 15011154, off-road conditions can be much more rigorous. Extreme care must be taken in off road conditions

**Note for Dealers and Fitters:**

It is your responsibility to ensure these fitting instructions are given to the end user or client.



# RCL, RCH 2,4,6 Kits

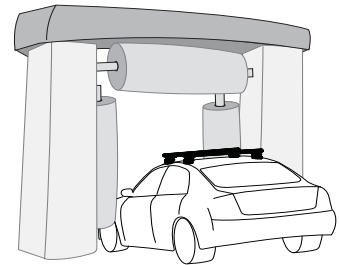
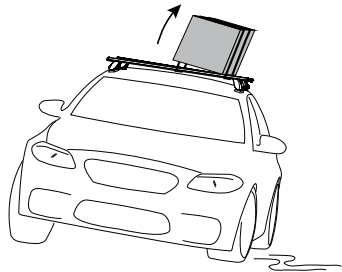
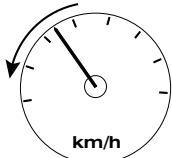
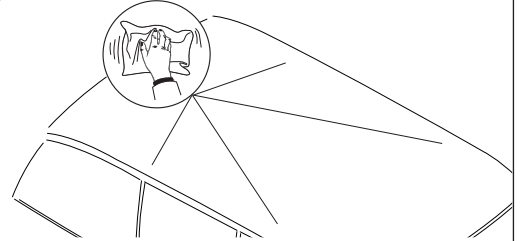
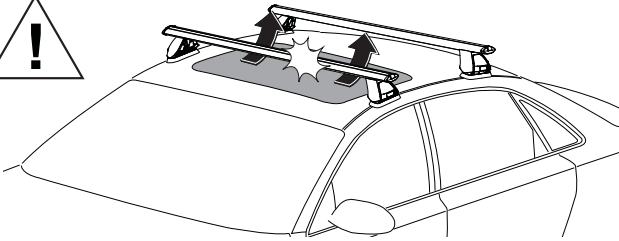
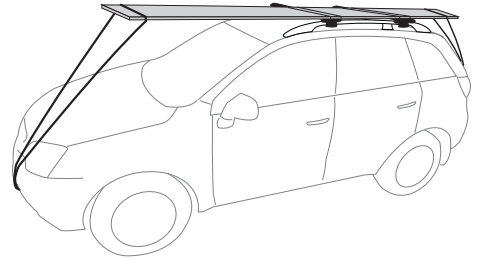
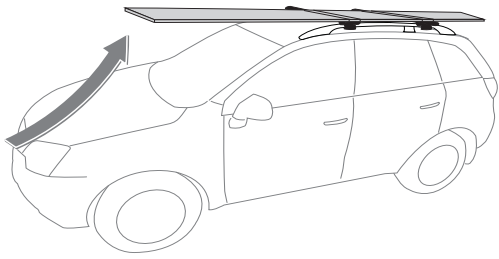

**Ensure Ladder is well supported on the ground to help support tent. Take extreme caution when climbing heights above 1.2m/4ft.**

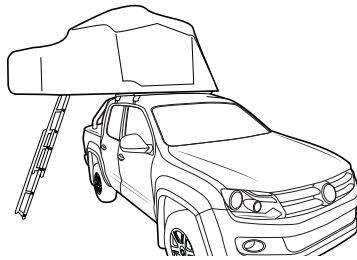

**It is required for Clam Shell Roof Top Tents to use a 3 Crossbar System.**

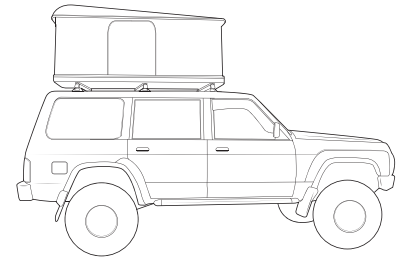

When these roof racks are to be used on a vehicle that is driven off sealed roads, the manufacturer maximum roof load rating (to be found in the vehicles User Manual) should be **divided by 1.5**. Do not forget to subtract the complete crossbar system weight from your maximum carrying capacity.

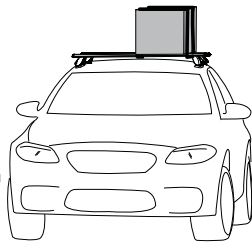

**100kg/220lbs**  
(Urban Road)



**66kg/145lbs**  
(Off Road)

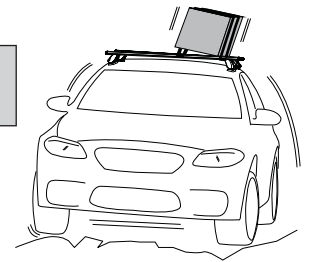

## WARNING! Important Load Carrying Instructions

With utility vehicles, the cabin and the canopy move independently. Roof racks and vehicle can be damaged if the item transported is rigidly fixed at points on both the cabin and canopy. Instead, rigidly fix to either the cabin roof racks or the canopy roof racks.

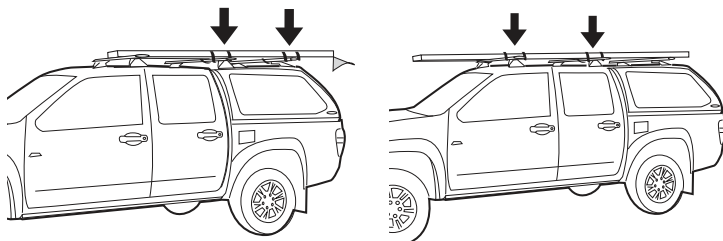

Paddle/ Surfboards should be fixed to the front of the vehicle.

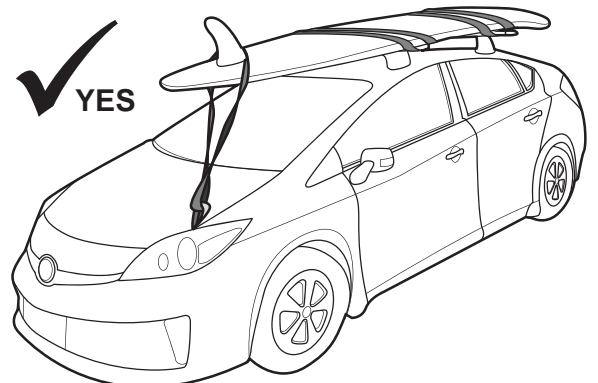



# RCL, RCH 2,4,6 Kits

## Parts List

Item	RCL	2 Kit Qty	4 Kit Qty	6 Kit Qty	Part No.
1	Locking Leg Cover (37mm)	2	4	6	M810
2	Locking Leg Base (37mm)	2	4	6	M813
3	Key Barrel	2	4	6	CA1339
4	Key	1	2	2	-
5	Allen Key	1	1	1	H034
6	M6 x 20mm Socket Head Screw	2	4	6	B054
7	M6 Spring Washer	2	4	6	W004
8	M6 x 16mm Flat Washer	2	4	6	W031
9	M6 Nut 30mm x 25mm	2	4	6	N035A
10	Instructions	1	1	1	R1182
Item	RCH	2 Kit Qty	4 Kit Qty	6 Kit Qty	Part No.
10	Locking Leg Cover (52mm)	2	4	6	M812
11	Locking Leg (52mm)	2	4	6	M811
3	Key Barrel	2	4	6	CA1339
4	Key	1	2	2	-
5	Allen Key	1	1	1	H021
6	M6 x 20mm Socket Head Screw	2	4	6	B054
7	M6 Spring Washer	2	4	6	W004
8	M6 x 16mm Flat Washer	2	4	6	W031
9	M6 Nut 30mm x 25mm	2	4	6	N035A
10	Instructions	1	1	1	R1182

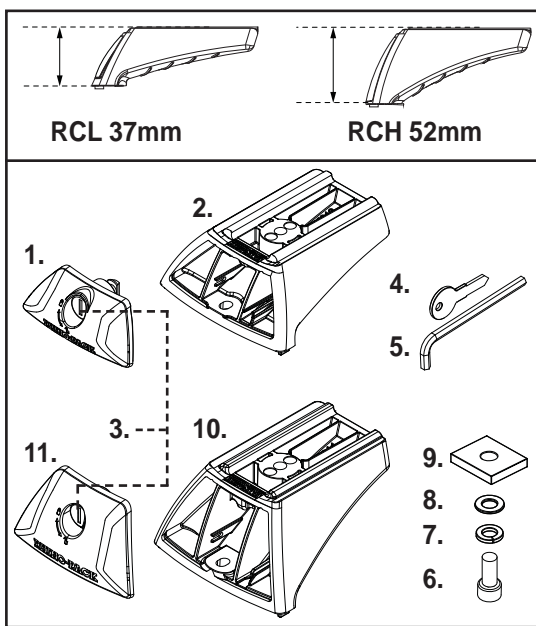

### Tools Required:

Allen Key (provided).  
Metal Key (provided).

### Notes:

Crossbars and Fit Kits are sold as separate and are required for individual vehicle fits.  
Heavy Duty Bars will require a QMHD05 kit.

## Instructions

- 1** Use the Metal Key provided to unlock the Cover Plate and remove. Remove the Allen Key from its storage position.

**Note: Low Leg used throughout instructions.**

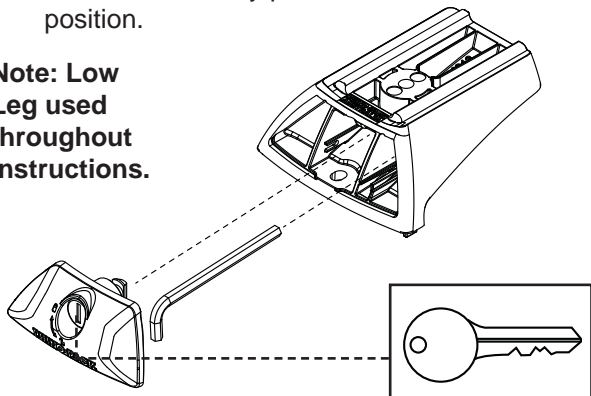

Front View:

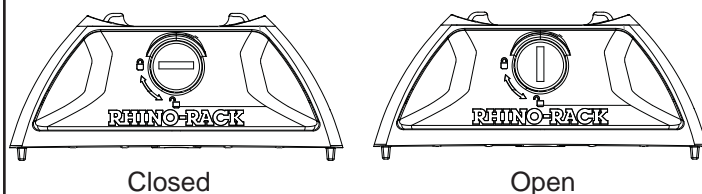

- 2** Insert the M6 hardware as shown. Finger tighten only at this stage.

M6 Nut 30mm x 25mm

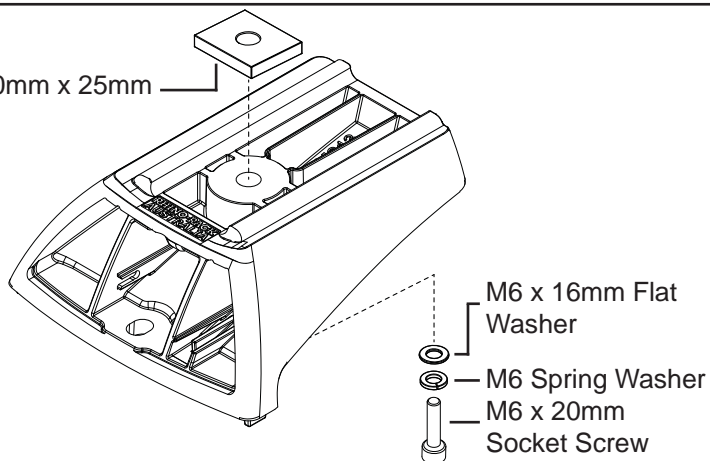



## RCL, RCH 2,4,6 Kits

- 3** Slide the Assembled legs into the Crossbars as shown. Insert Vortex Rubber, cut to length as required.

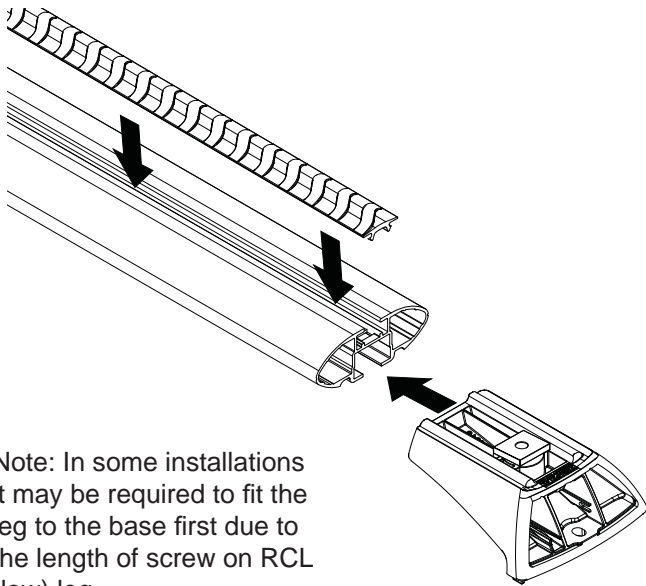

Note: In some installations it may be required to fit the leg to the base first due to the length of screw on RCL (low) leg.

- 4** Fix the Crossbars to the vehicle specific Base Kit that has been purchased, using the Allen Key provided.

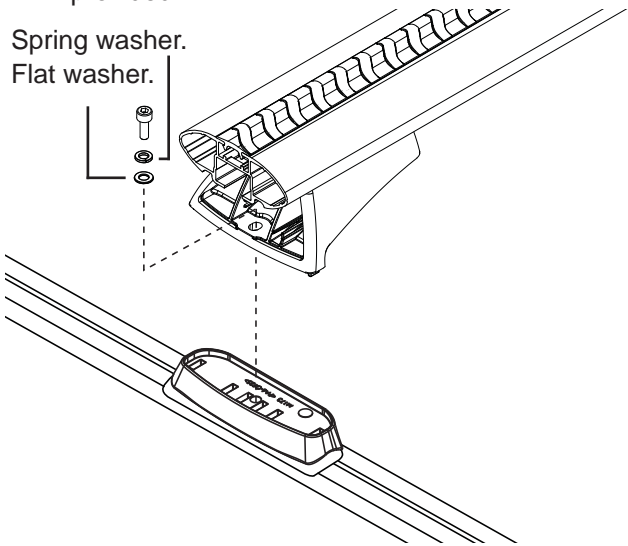

Note: Images are example only. RCL/RCH legs can be fit to either tracks or pads. Pads and track fit kits are sold as separate.

- 5** Ensure the Crossbars have an equal overhang. Tighten the M6 Leg Hardware with the Allen Key provided.

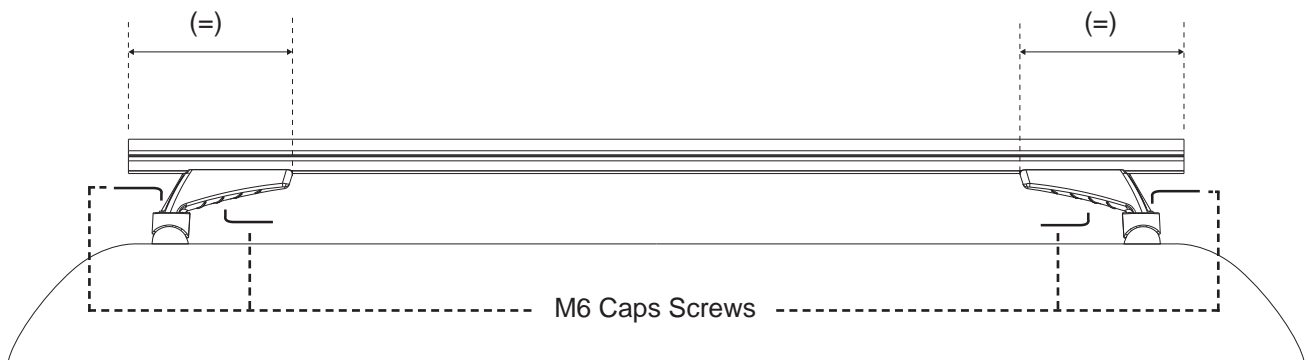

- 6** Insert the Underbar Strips into the slots either side of the installed Leg. Cut to length as required.

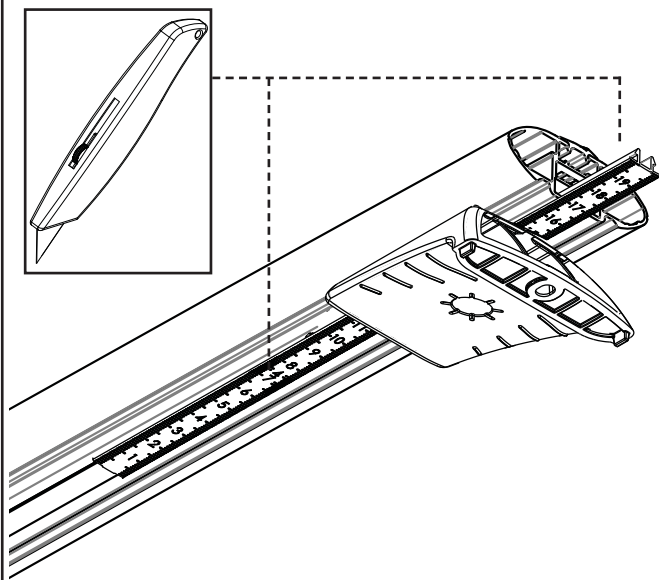

- 7** Insert the Crossbar End Caps and lock in place. Replace the Allen Key and Leg Cover. Lock the Leg Cover Plate with the key provided. Be sure all fixtures are secure before use.

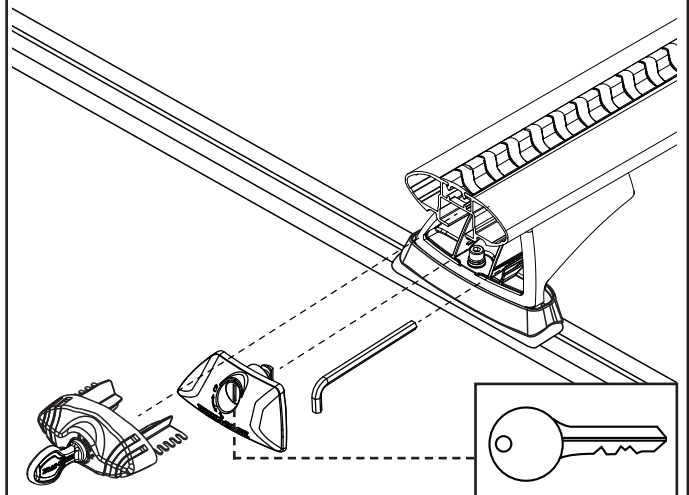





# RCL, RCH 2,4,6 Kits

**Note** To fit Legs to Heavy Duty Crossbars, Pioneer Trays and Platforms Pioneer QMHD05 must be purchased as separate. Install the Spacer Kit then the HD Crossbars.

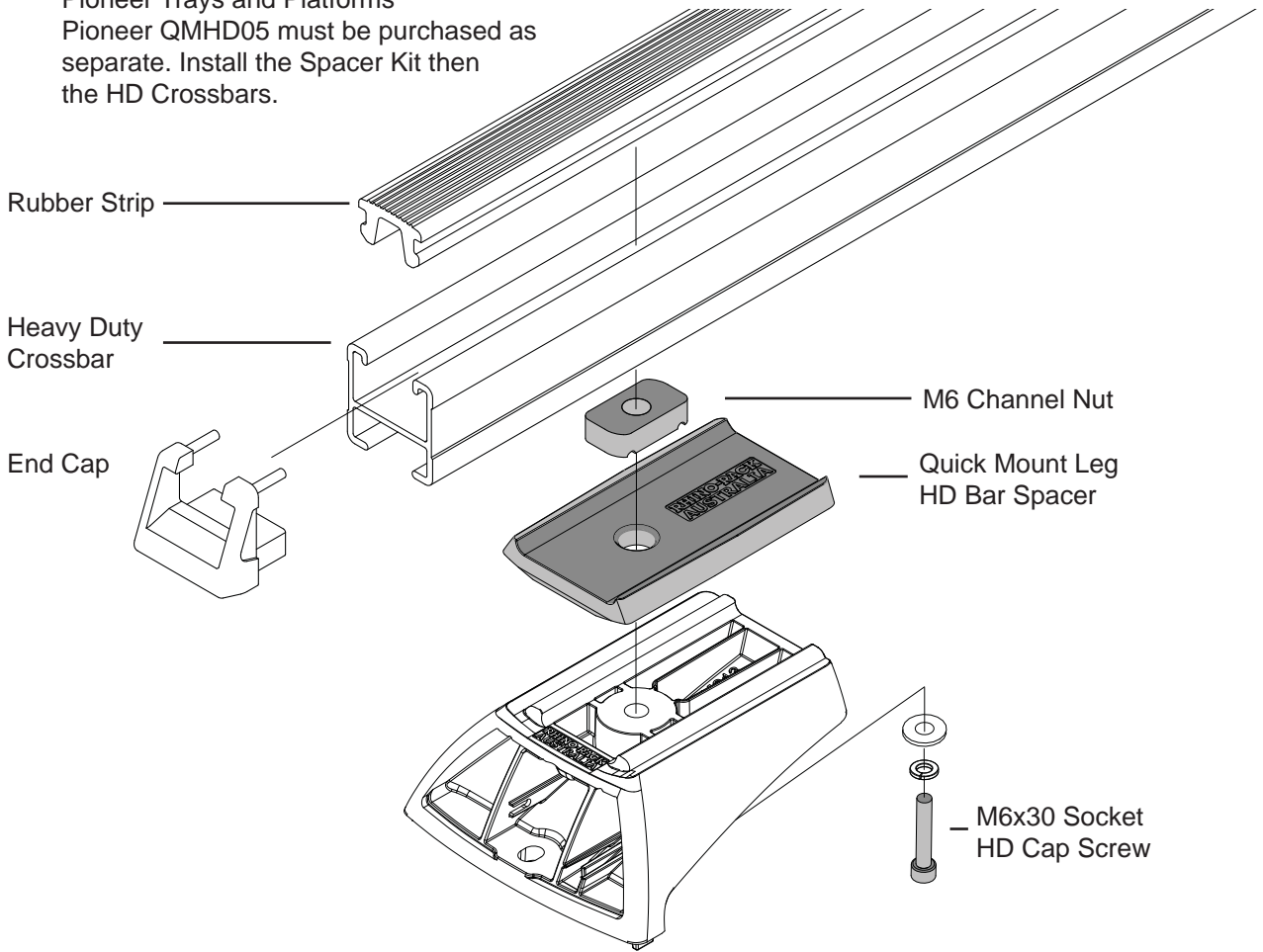

To fit Legs to Pioneer Trays/ Platforms, positioned wide on vehicle, QMPS10 must be purchased as separate. Install the Spacer Kit then the Tray/ Platform.

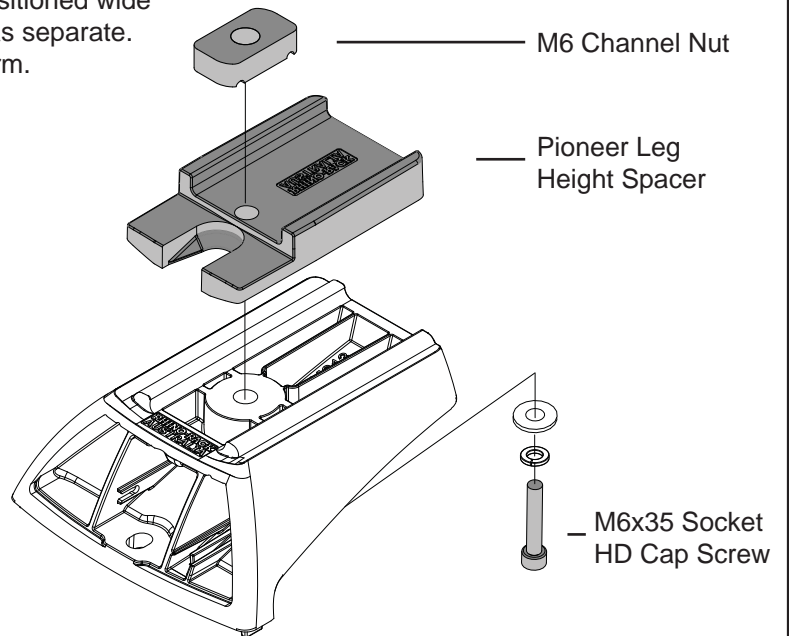

Check all fixtures are secure before use.

