

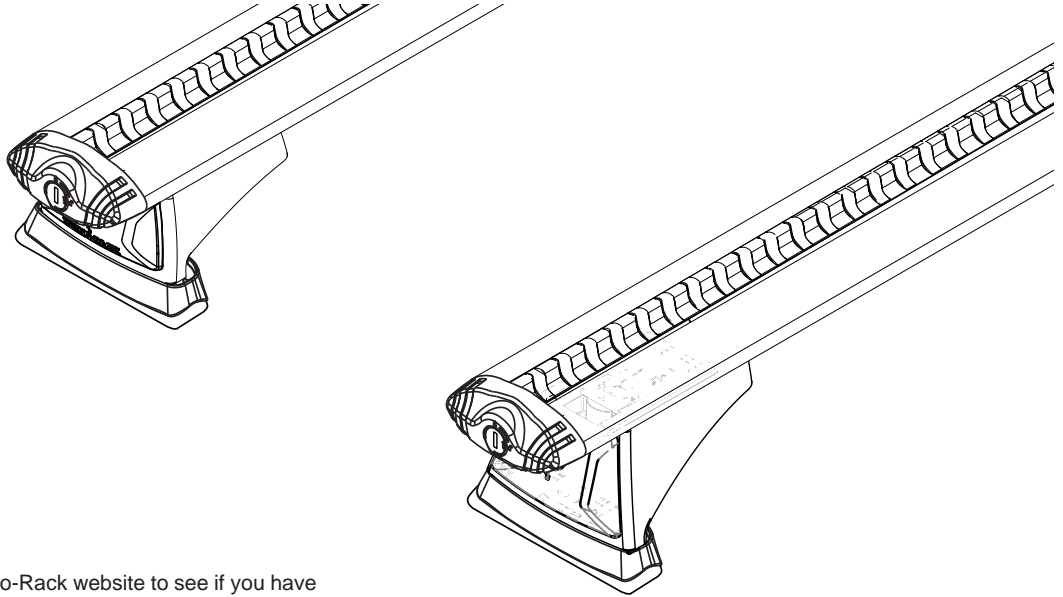

# RHINO-RACK

## RCL, RCH 2,4,6 Kits

**Important:** Please read these instructions carefully prior to installation. Please refer to your fitting instruction to ensure that the Roof Rack System is installed in the correct location. Check the contents of kit before commencing fitment and report any discrepancies. Place these instructions in the vehicle's glove box after installation is complete.



**Note:** Be sure to check Rhino-Rack website to see if you have the latest version of instructions before beginning installation.

**Maximum load carrying capacity: 100kg / 220lbs**

### Important Information

- Check Part No./Kit is correct
- Read through instruction before installing
- Fit roof rack accessory
- Check and recheck all fasteners are secure

**Maximum carrying capacity: Up to 100kg (220lbs)** including the weight of the rack system.

Please refer to your vehicle manufacturers handbook for maximum carrying capacity. Always use the lower of the two figures. Load must be evenly distributed over the entire basket.

**Warning:** Do not attempt to fit the rack system to your vehicle unless you fully understand these fitting instructions. Please direct any questions regarding fitting to the dealer from where the roof racks were purchased.

**Use only non-stretch fastening ropes or straps.**

**Recommendations:** It is essential that all bolt connections be checked after driving a short distance when you first install your roof racks. Bolt connections should be checked again at regular intervals (once a week is enough, depending on road conditions, usage, loads and distances travelled). You should also check the roof racks each time they are re-fitted. Always make sure to fasten your load securely. Please also ensure that all loads are evenly distributed and that the centre of gravity is kept as low as possible and must be entirely contained within the extents of the roof racks. **Rack System must be removed when putting vehicle through an automatic car wash.**

**Caution:** The handling characteristics of the vehicle changes when you transport a load on the roof. For safety reasons we recommend you exercise extreme care when transporting wind-resistant loads. Special consideration must be taken into account when cornering and braking.

**Off-road use:**

The Roof Rack System may be used in off road applications, however a safety factor of 1.5 is enforced. That is, maximum permissible off road load is **66kg (145lbs)**. Although the crossbars are tested and approved to AS1235-2000/ 15011154, off-road conditions can be much more rigorous. Extreme care must be taken in off road conditions



# RCL, RCH 2,4,6 Kits

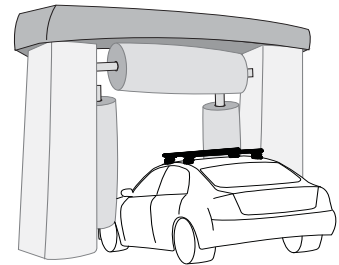
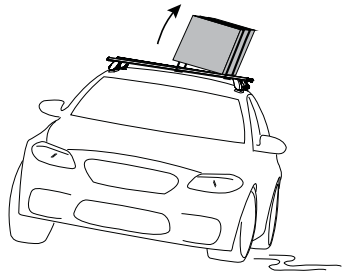
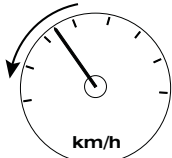
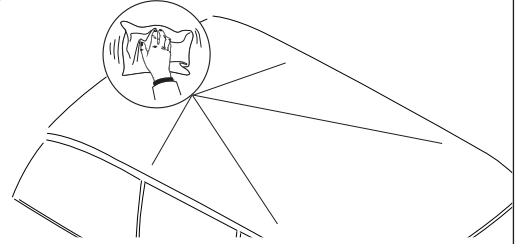
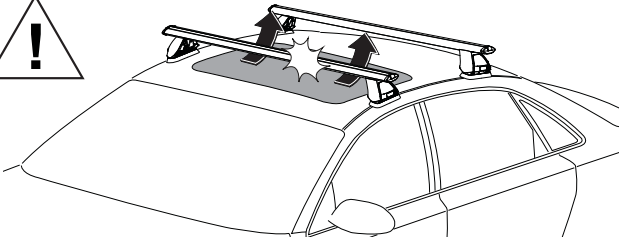
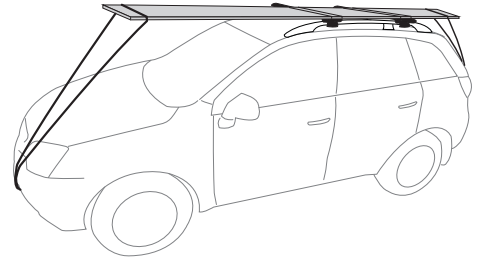
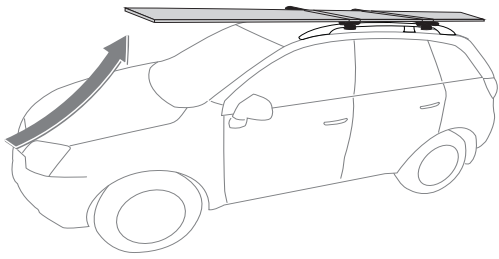

**Ensure Ladder is well supported on the ground to help support tent. Take extreme caution when climbing heights above 1.2m/4ft.**

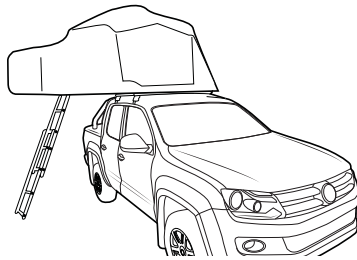

**It is required for Clam Shell Roof Top Tents to use a 3 Crossbar System.**

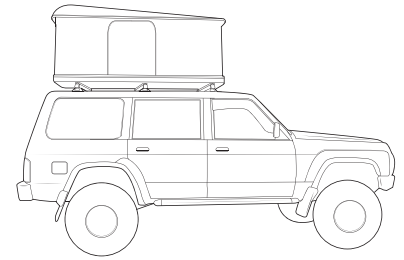

When these roof racks are to be used on a vehicle that is driven off sealed roads, the manufacturer maximum roof load rating (to be found in the vehicles User Manual) should be **divided by 1.5**. Do not forget to subtract the complete crossbar system weight from your maximum carrying capacity.

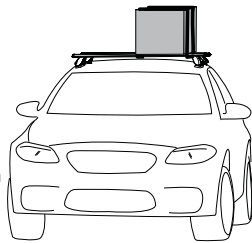

**100kg/220lbs**  
(Urban Road)



**66kg/145lbs**  
(Off Road)

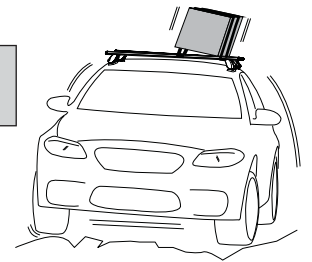

## WARNING! Important Load Carrying Instructions

With utility vehicles, the cabin and the canopy move independently. Roof racks and vehicle can be damaged if the item transported is rigidly fixed at points on both the cabin and canopy. Instead, rigidly fix to either the cabin roof racks or the canopy roof racks.

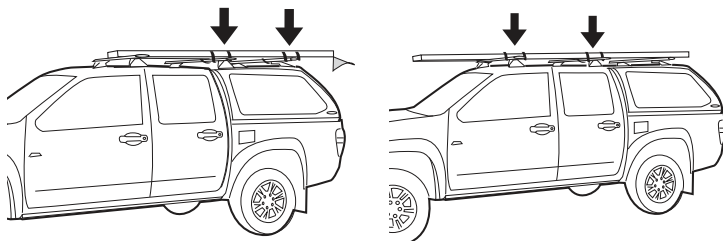

Paddle/ Surfboards should be fixed to the front of the vehicle.

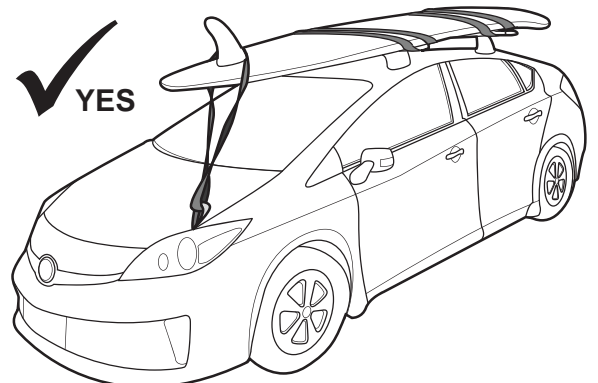



# RCL, RCH 2,4,6 Kits

## Parts List

Item	RCL	2 Kit Qty	4 Kit Qty	6 Kit Qty	Part No.
1	Locking Leg Cover (37mm)	2	4	6	M810
2	Locking Leg Base (37mm)	2	4	6	M813
3	Key Barrel	2	4	6	CA1339
4	Key	1	2	2	-
5	Allen Key	1	1	1	H034
6	M6 x 20mm Socket Head Screw	2	4	6	B054
7	M6 Spring Washer	2	4	6	W004
8	M6 x 16mm Flat Washer	2	4	6	W031
9	M6 Nut 30mm x 25mm	2	4	6	N035A
10	Instructions	1	1	1	R1182
Item	RCH	2 Kit Qty	4 Kit Qty	6 Kit Qty	Part No.
10	Locking Leg Cover (52mm)	2	4	6	M812
11	Locking Leg (52mm)	2	4	6	M811
3	Key Barrel	2	4	6	CA1339
4	Key	1	2	2	-
5	Allen Key	1	1	1	H021
6	M6 x 20mm Socket Head Screw	2	4	6	B054
7	M6 Spring Washer	2	4	6	W004
8	M6 x 16mm Flat Washer	2	4	6	W031
9	M6 Nut 30mm x 25mm	2	4	6	N035A
10	Instructions	1	1	1	R1182

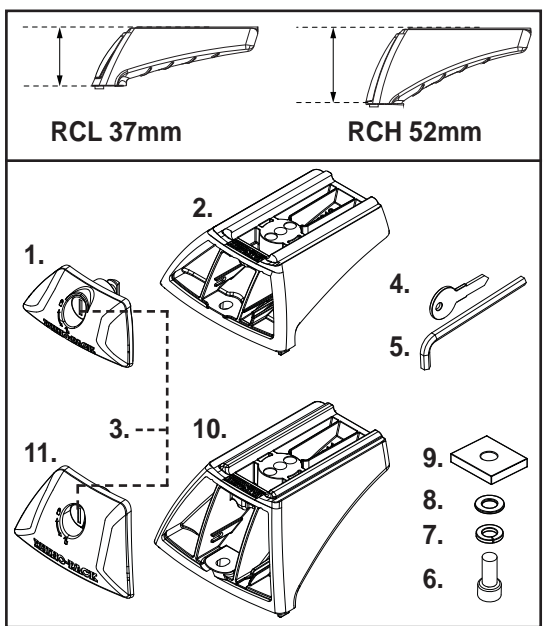

### Tools Required:

Allen Key (provided).  
Metal Key (provided).

### Notes:

Crossbars and Fit Kits are sold as separate and are required for individual vehicle fits.  
Heavy Duty Bars will require a QMHD05 kit.

## Instructions

- 1** Use the Metal Key provided to unlock the Cover Plate and remove. Remove the Allen Key from its storage position.

**Note: Low Leg used throughout instructions.**

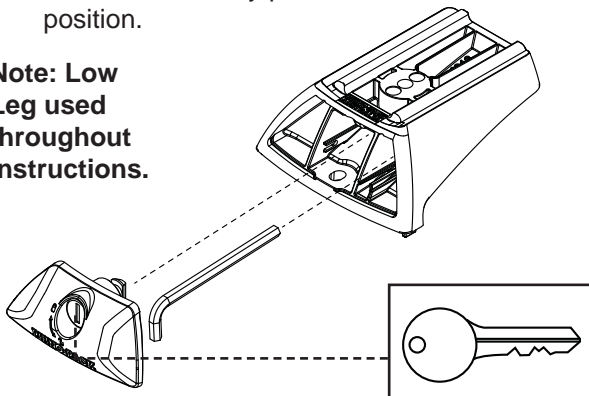

Front View:

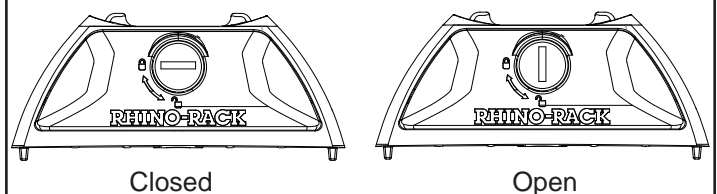

- 2** Insert the M6 hardware as shown. Finger tighten only at this stage.

M6 Nut 30mm x 25mm

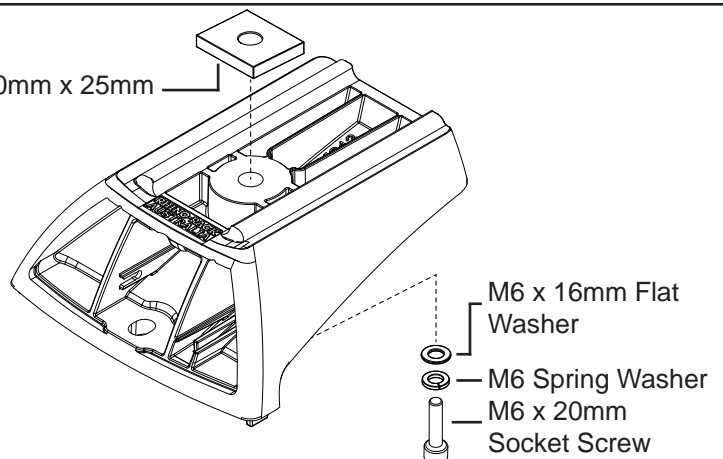



## RCL, RCH 2,4,6 Kits

- 3** Slide the Assembled legs into the Crossbars as shown. Insert Vortex Rubber, cut to length as required.

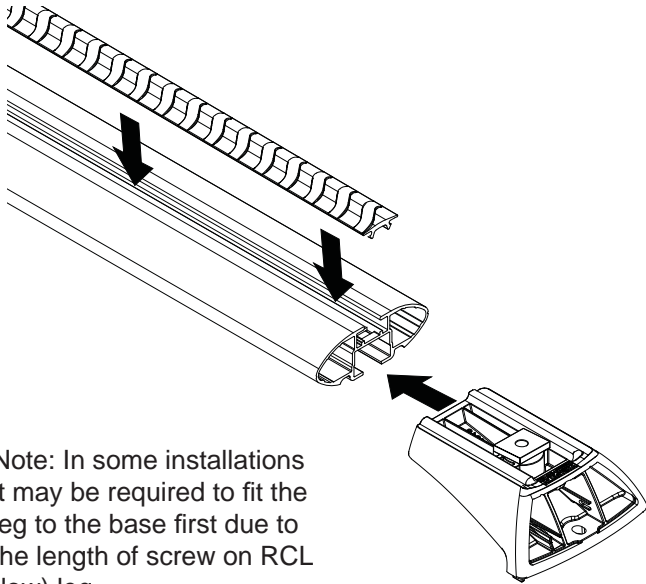

Note: In some installations it may be required to fit the leg to the base first due to the length of screw on RCL (low) leg.

- 4** Fix the Crossbars to the vehicle specific Base Kit that has been purchased, using the Allen Key provided.

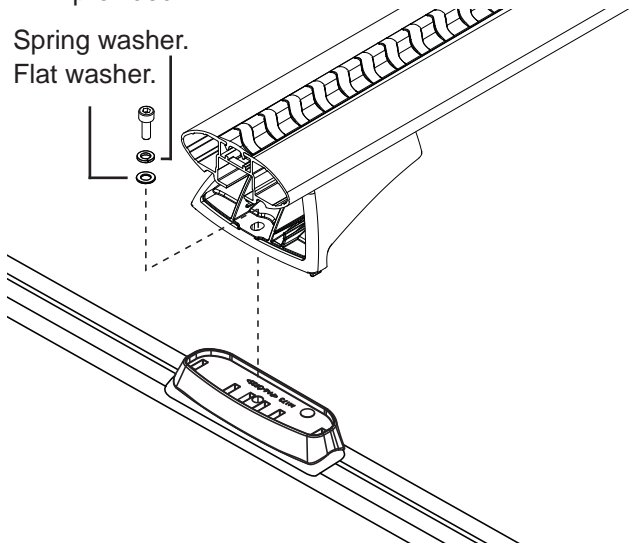

Note: Images are example only. RCL/RCH legs can be fit to either tracks or pads. Pads and track fit kits are sold as separate.

- 5** Ensure the Crossbars have an equal overhang. Tighten the M6 Leg Hardware with the Allen Key provided.

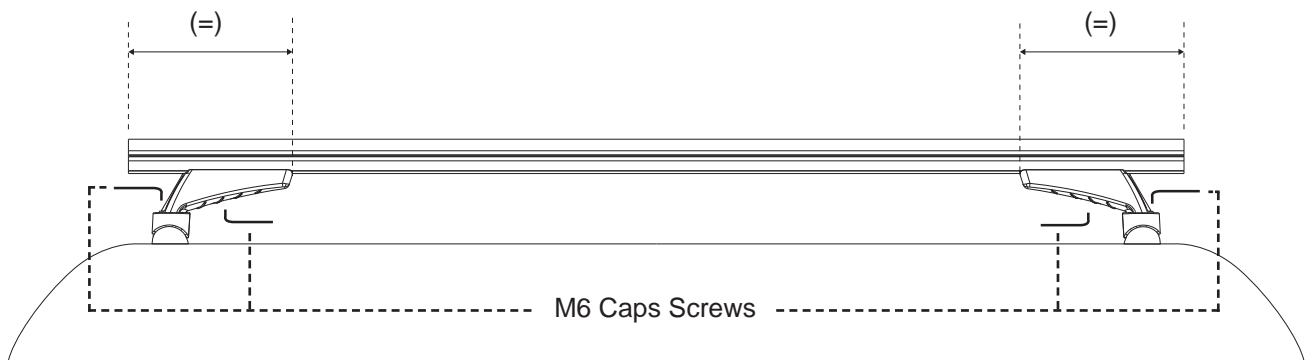

- 6** Insert the Underbar Strips into the slots either side of the installed Leg. Cut to length as required.

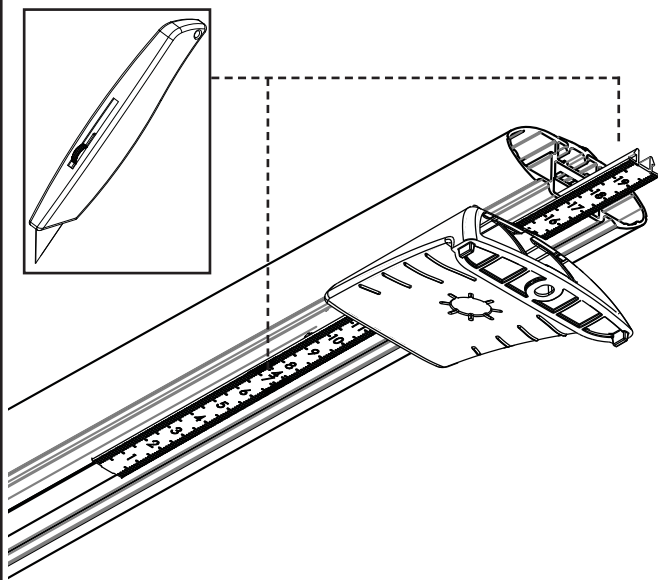

- 7** Insert the Crossbar End Caps and lock in place. Replace the Allen Key and Leg Cover. Lock the Leg Cover Plate with the key provided. Be sure all fixtures are secure before use.

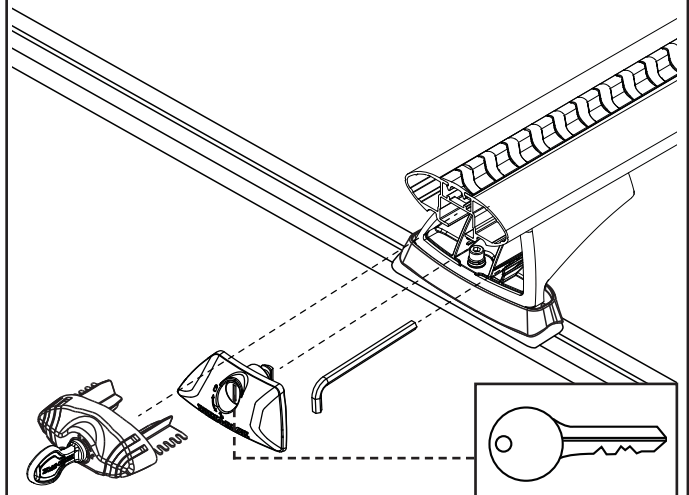



# RCL, RCH 2,4,6 Kits

**Note** To fit Legs to Heavy Duty Crossbars, Pioneer Trays and Platforms Pioneer QMHD05 must be purchased as separate. Install the Spacer Kit then the HD Crossbars.

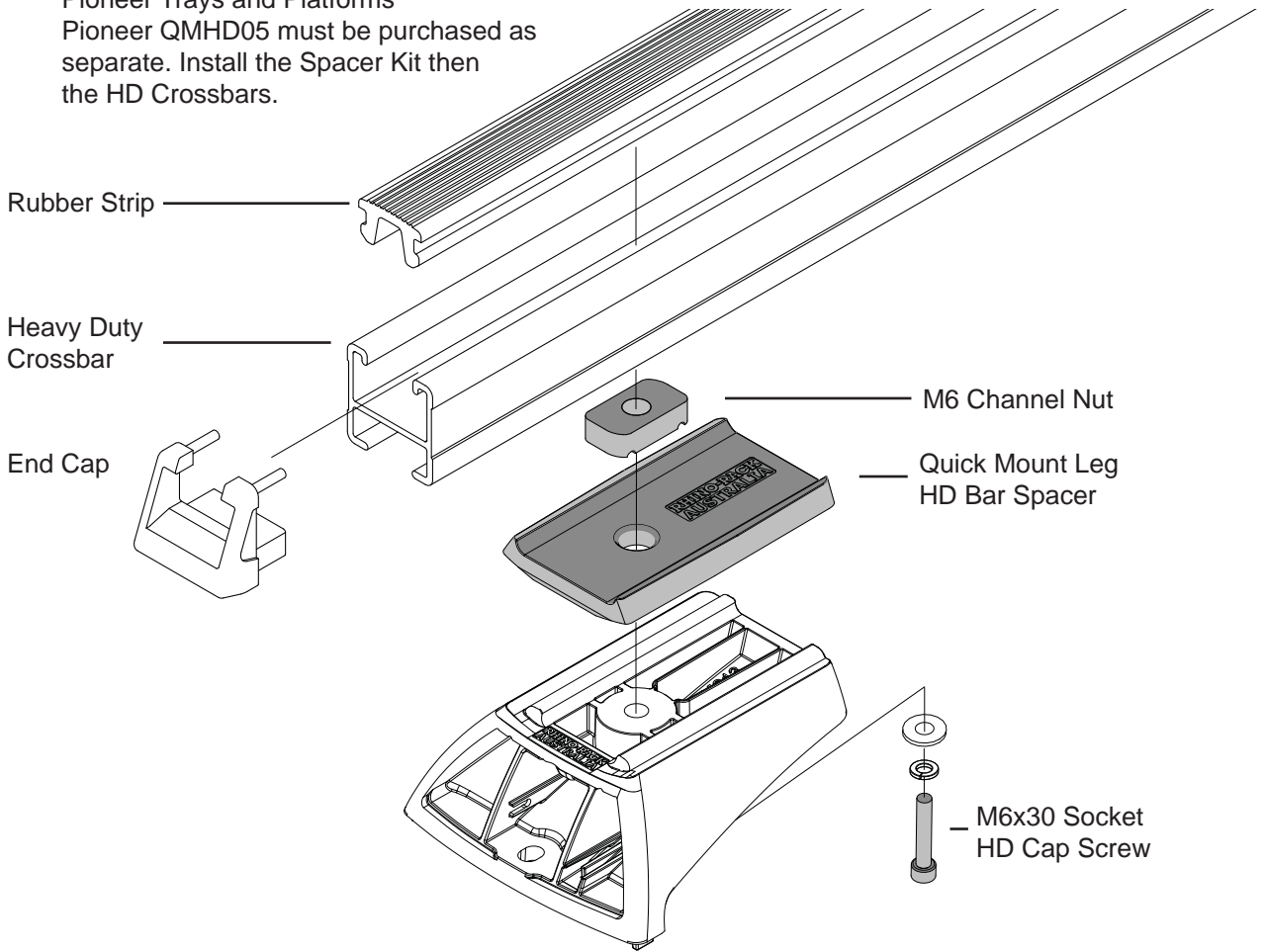

To fit Legs to Pioneer Trays/ Platforms, positioned wide on vehicle, QMPS10 must be purchased as separate. Install the Spacer Kit then the Tray/ Platform.

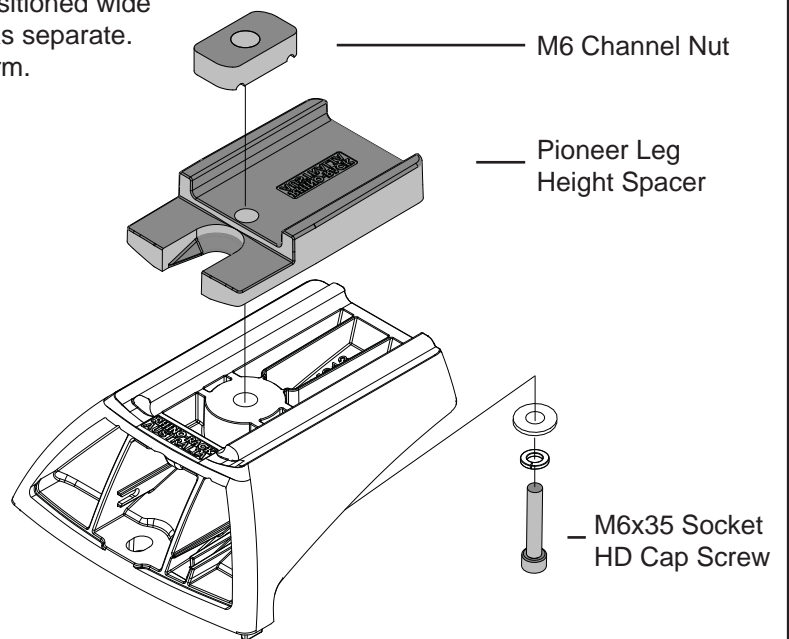

Check all fixtures are secure before use.

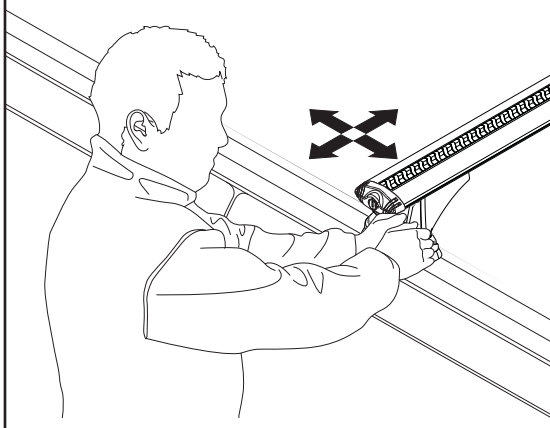



# RHINO-RACK

## Toyota Kluger/Highlander SUV XU50 RCP37-BK

**Important:** Please read these instructions carefully prior to installation.  
Please refer to your fitting instruction to ensure that the Roof Rack System is installed in the correct location.  
Check the contents of kit before commencing fitment and report any discrepancies.  
Place these instructions in the vehicle's glove box after installation is complete.

### Layout:

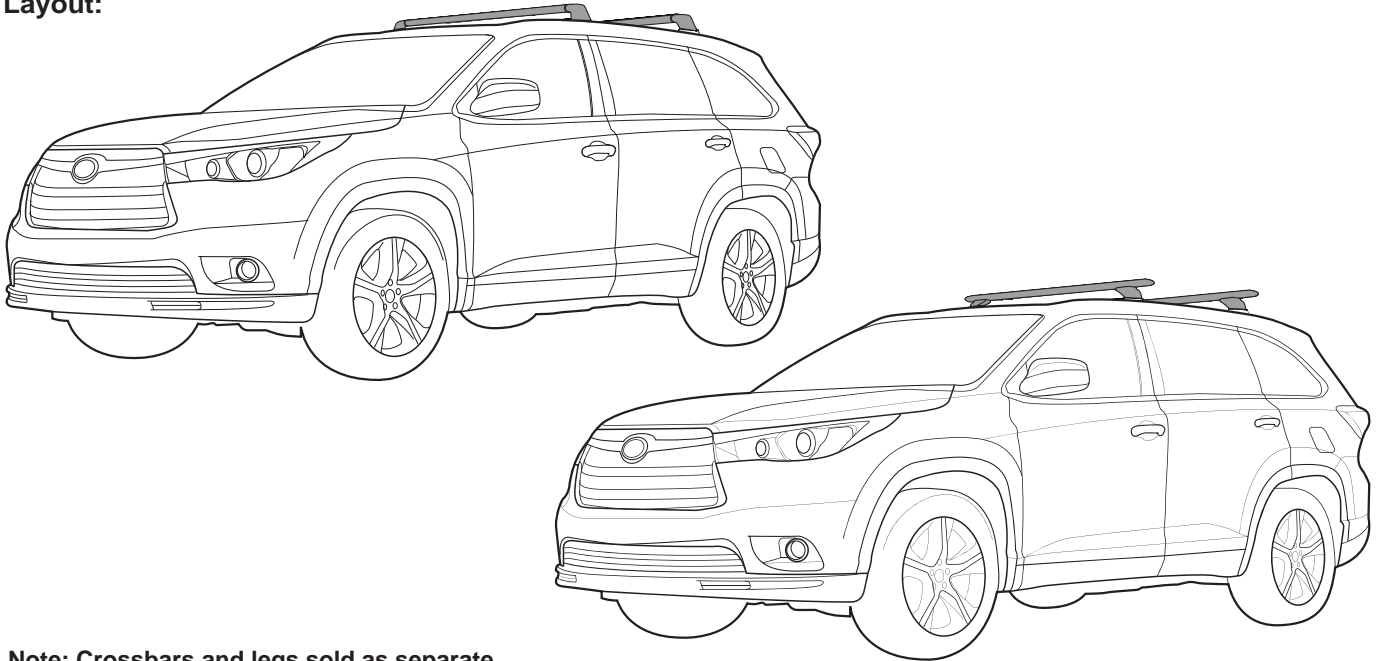

**Note:** Crossbars and legs sold as separate.

### Important Information

1.  Check Part No./Kit is correct
2.  Read through instruction before installing
3.  Fit roof rack accessory
4.  Check and recheck all fasteners are secure

**Maximum carrying capacity: 80kg (176lbs)** including the weight of the rack system **5kg (11lbs)**. **Note: Be sure to check Rhino-Rack website to see if you have the latest version of instructions before beginning installation.**

Please refer to your vehicle manufacturers handbook for maximum carrying capacity. Always use the lower of the two figures. Load must be evenly distributed over the entire basket.

**Warning:** Do not attempt to fit the roof rack system to your vehicle unless you fully understand these fitting instructions. Please direct any questions regarding fitting to the dealer from where the roof racks were purchased.

**Use only non-stretch fastening ropes or straps.**

**Recommendations:** It is essential that all bolt connections be checked after driving a short distance when you first install your roof racks. Bolt connections should be checked again at regular intervals (once a week is enough, depending on road conditions, usage, loads and distances travelled). You should also check the roof racks each time they are re-fitted. Always make sure to fasten your load securely. Please also ensure that all loads are evenly distributed and that the centre of gravity is kept as low as possible and must be entirely contained within the extents of the roof racks.

**Caution:** The handling characteristics of the vehicle changes when you transport a load on the roof. For safety reasons we recommend you exercise extreme care when transporting wind-resistant loads. Special consideration must be taken into account when cornering and braking.

#### Off-road use:

The Roof Rack System may be used in off road applications, however a safety factor of 1.5 is enforced. That is, maximum permissible off road load is **53kg 117lbs**). Although the crossbars are tested and approved to AS1235-2000, off-road conditions can be much more rigorous. Increasing the number of crossbars does not increase the vehicles maximum permissible roof loading.

#### Note for Dealers and Fitters:

It is your responsibility to ensure these fitting instructions are given to the end user or client.

Rhino-Rack 3 Pike Street, Rydalmere,



# Toyota Kluger/Highlander SUV XU50 RCP37-BK

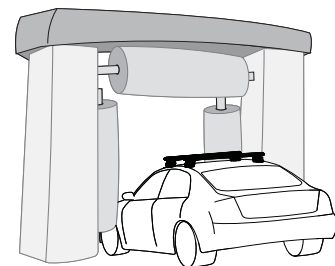
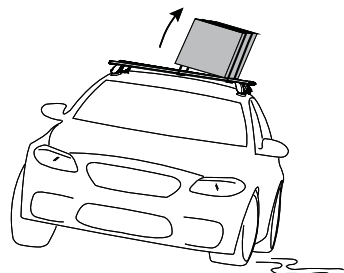
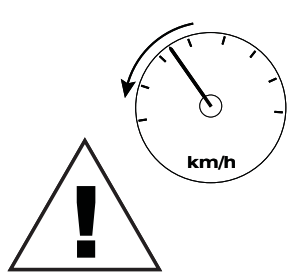
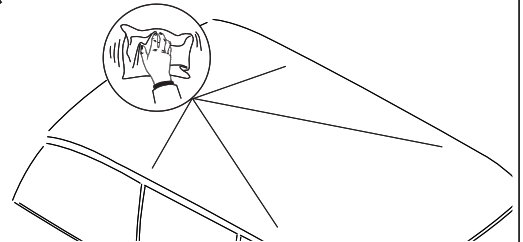
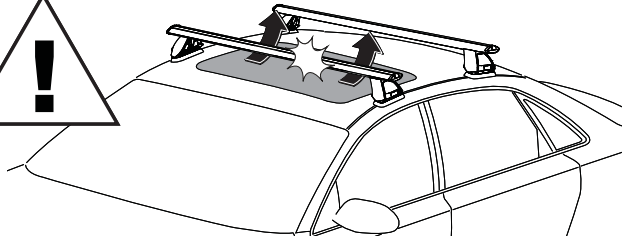
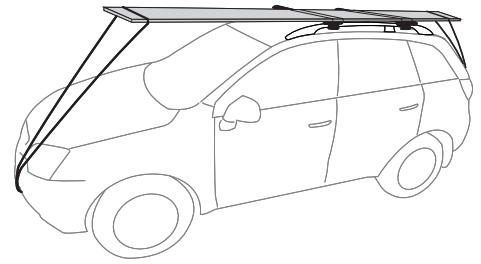
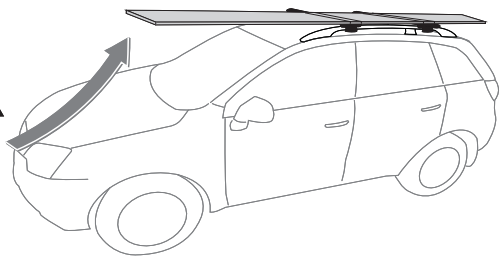

**Ensure Ladder is well supported on the ground to help support tent. Take extreme caution when climbing heights above 1.2m/4ft.**

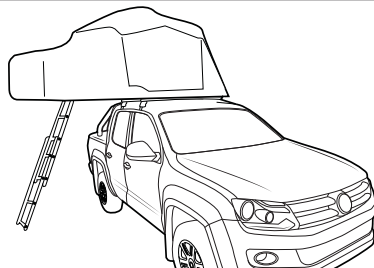

**It is a requirement for Clam Shell Roof Top Tents to use a 3 Crossbar System.**

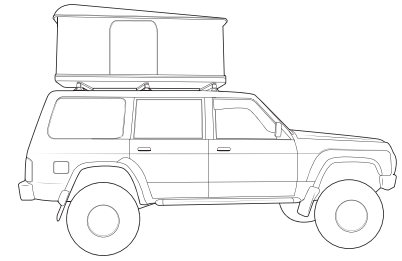

When these roof racks are to be used on a vehicle that is driven off sealed roads, the maximum roof rack load rating should be **divided by 1.5**. Do not forget to subtract 5kg from your maximum carrying capacity due to the weight of the crossbars and legs.

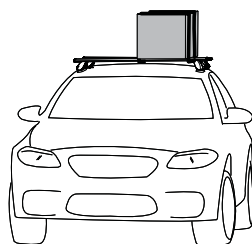

**80kg/176lbs**  
load rating  
(Urban road)

**53kg/117lbs**  
load rating  
(Off road  
- 80kg / 1.5)

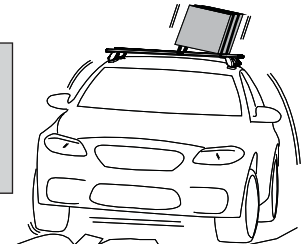

## WARNING! Important Load Carrying Instructions

With utility vehicles, the cabin and the canopy move independently. Roof racks and vehicle can be damaged if the item transported is rigidly fixed at points on both the cabin and canopy. Instead, rigidly fix to either the cabin roof racks or the canopy roof racks.

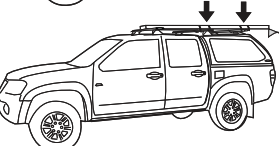
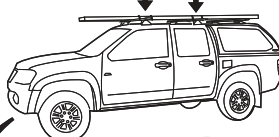
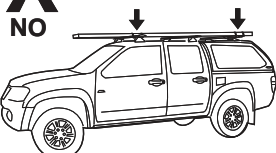

Paddle/ Surfboards should be fixed to the front of the vehicle.

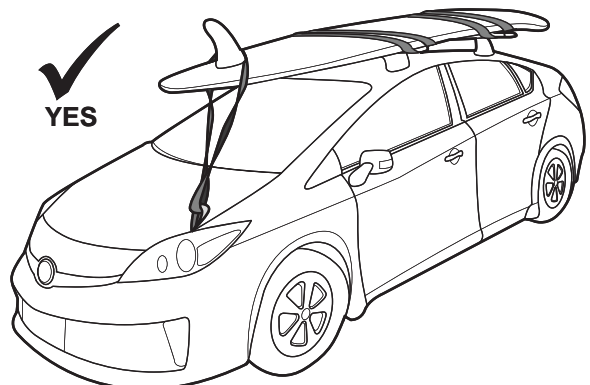



# Toyota Kluger/Highlander SUV XU50 RCP37-BK

## Parts List

Item	Component Name	Qty	Part No.
1	M6 x 30mm Hex Setscrew	4	B202
2	M6 Spring Washer	4	W004
3	M6 x 16mm Flat Washer	4	W031
4	M8 x 40mm Socket Screw	8	B162T
5	M8 Spring Washer	8	W019
6	M8 Flat Washer	8	W043
7	7mm x 4mm O-Ring	8	C299
8	Front Left Mount Pad	1	M391
9	Front Right Mount Pad	1	M392
10	Rear Left Mount Pad	1	M393
11	Rear Right Mount Pad	1	M394
12	Left Pad Mount Skirt	2	M395
13	Right Pad Mount Skirt	2	M396
14	Mounting Pad Washer	8	C588
15	6mm Hex Allen Key	1	H009
16	M6 Washer (used on cover plate)	4	W003
17	Cover Plate	4	M126
18	Fitting Instruction	1	R1338

### Tools Required:

Flat screwdriver.  
Socket wrench  
10mm,  
13mm socket

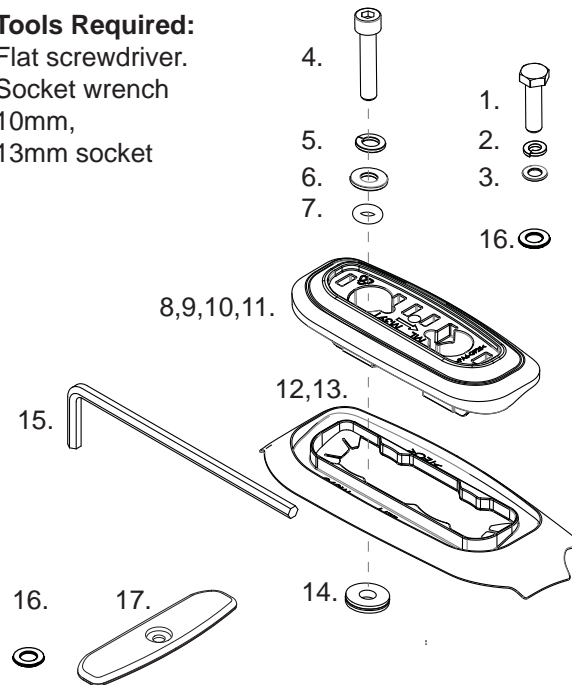

## Instructions

1

Remove the roof trim covers with a flat blade screwdriver carefully. Remove all brackets, bolts and washers using a 13mm socket. Store the covers and attachment hardware for future use if needed.

NOTE: The existing bolts and washers are not used to fit the roof rack mounting pads.

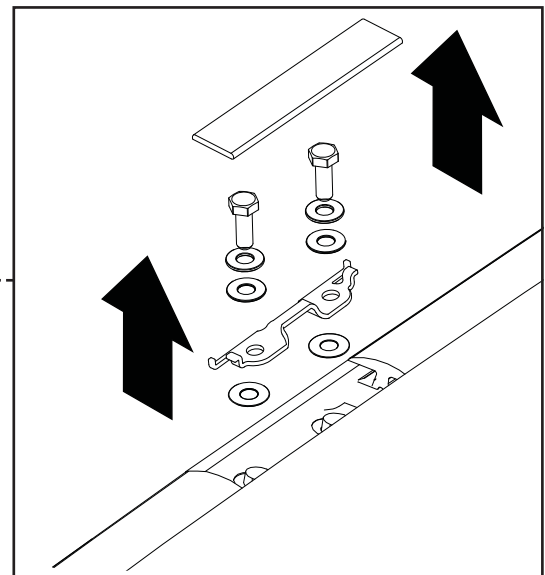
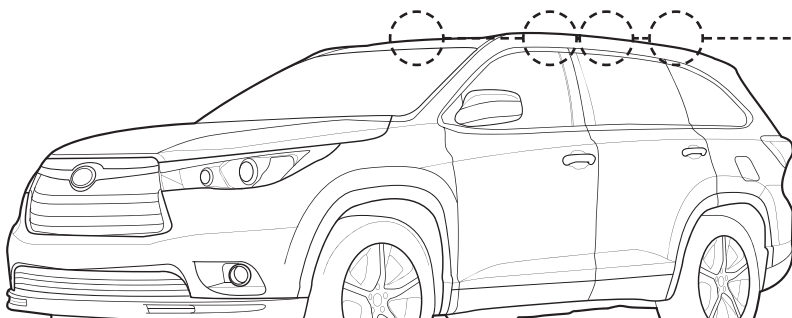

2

Place the foam covered mounting pad washers (item 18) over the plastic tubes in the roof channel. Make sure they are fitted neatly around the plastic tubes.

NOTE: Failure to fit the foam covered copper washers will result in water leaks.

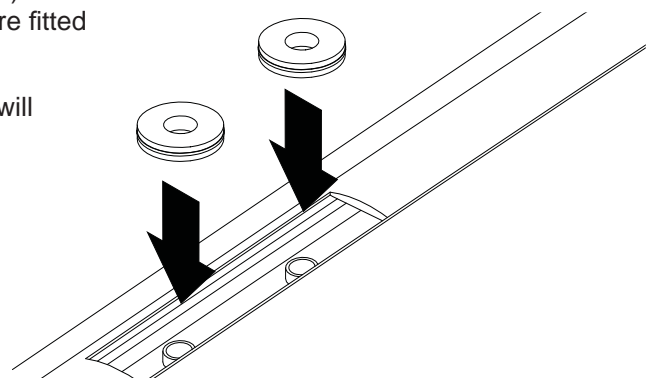
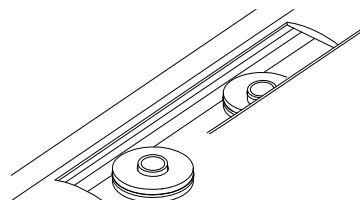





## Toyota Kluger/Highlander SUV XU50 RCP37-BK

3

Match the appropriate rubber skirts (item 16 and 17) with the mounting pads

Item 16 - Left Pad Mount Skirt  
FL = Front Left (M391)  
RL = Rear Left (M393)

Item 17 - Left Pad Mount Skirt  
FR = Middle Right (M392)  
RR = Rear Right (M394)

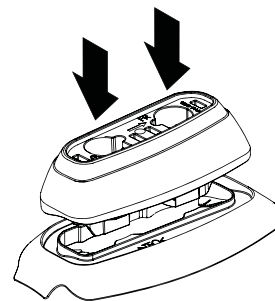

FRONT  
(Top view of vehicle)

Arrows on top of parts must point towards FRONT of vehicle when correctly installed.

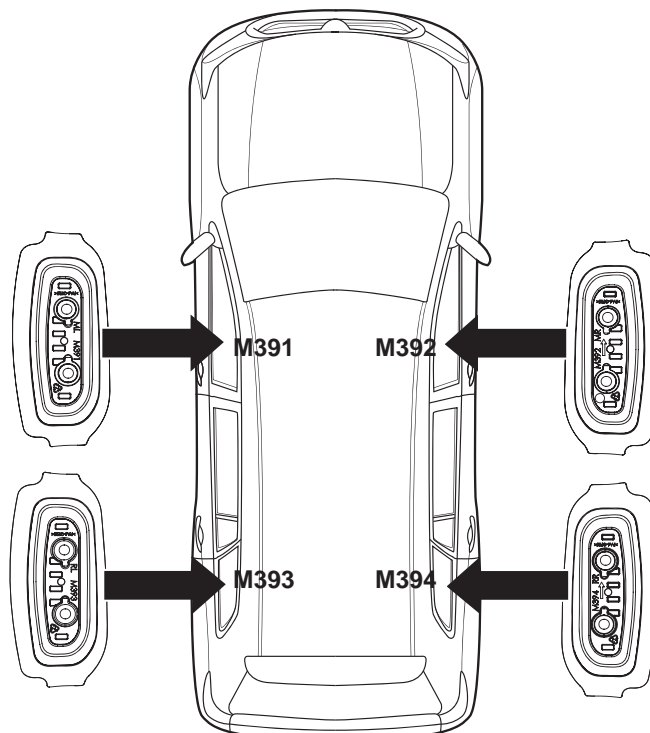
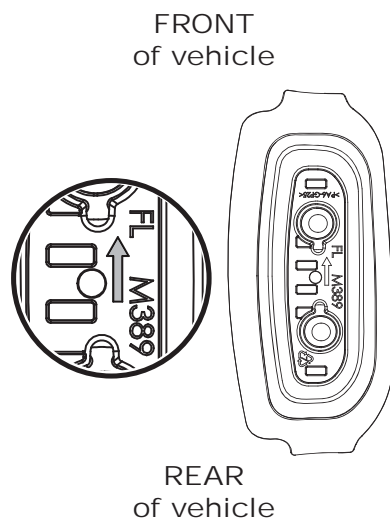

4

Place each pad into its position as stated in the previous step. Check to make sure the rubber skirt does NOT fold or twist when placed on the roof. It must flare out over surface of the roof.

Assemble M8 x 40mm bolt, washers and O-ring in the order shown. Push the O-ring up against the washers before locating into mounting pad. Finger tighten each pad first to ensure all parts are seated correctly.

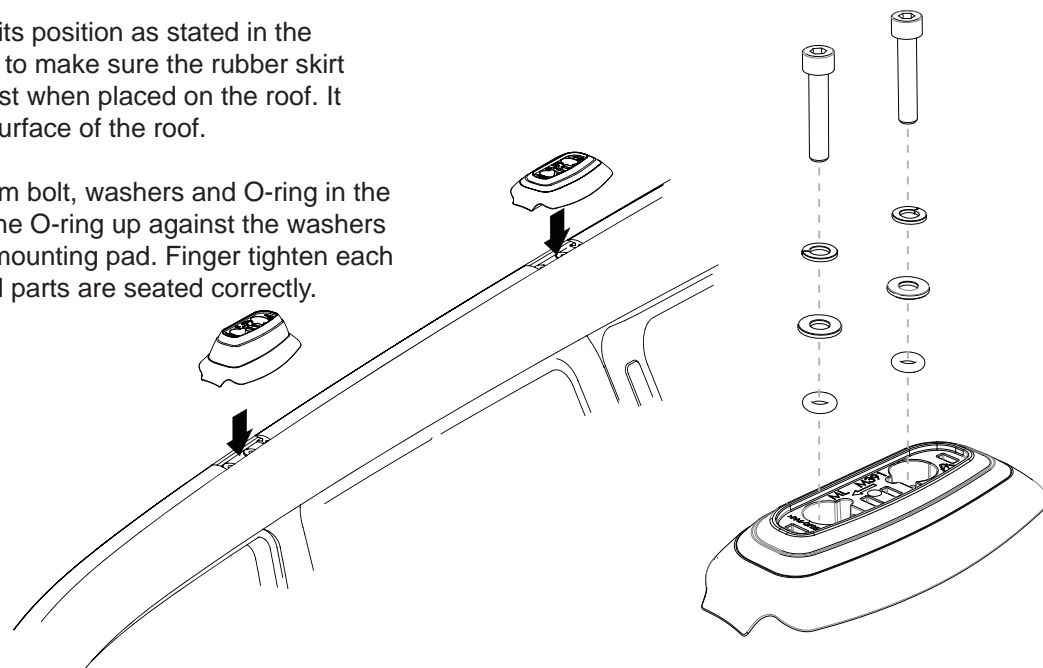



## Toyota Kluger/Highlander SUV XU50 RCP37-BK

5

Tighten all M8 bolts using the 6mm allen key supplied.

Recommended tightening torque 9-11 Nm.  
DO NOT OVER TIGHTEN.

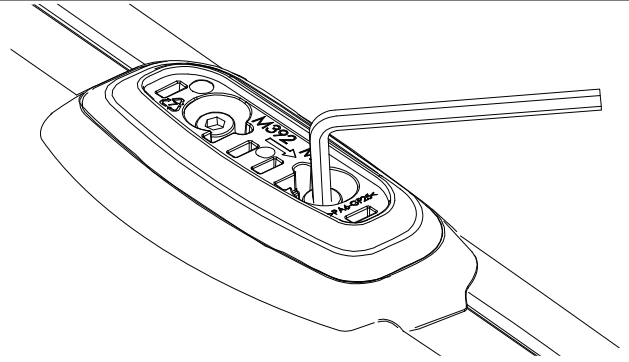

6

Fix the completed crossbars to the vehicle with an M6x30mm hex setscrew, M6 spring and 16mm flat washer (RVH shown as example only).

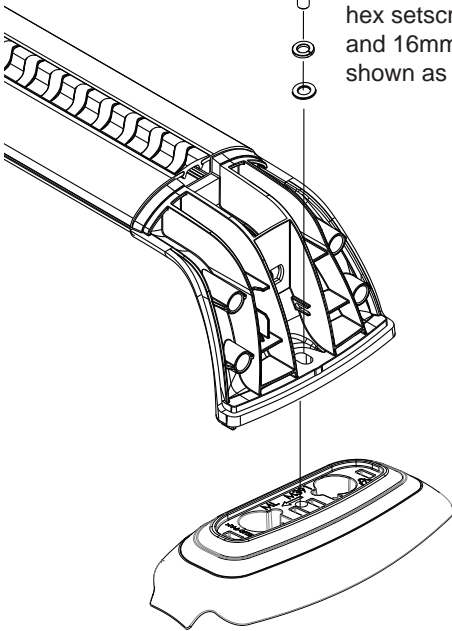

7

When crossbars are not in use, remove and install the cover plates as shown.

M6x30  
Hex Set-  
screw

M6 Spring  
Washer

M6 x16mm  
Flat  
Washer

