

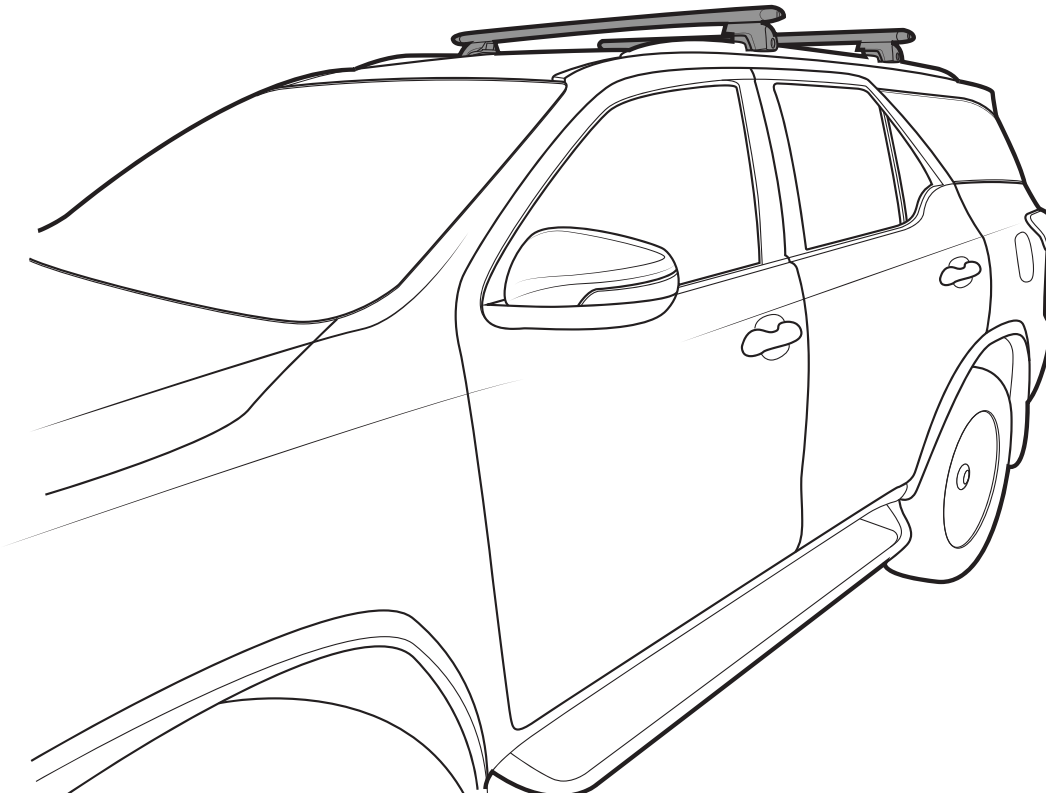

RHINO-RACK

Toyota Fortuner SX046

- Important:**
- 1. Please refer to your fitting instruction to ensure that the roof racks are installed in the correct locations.
 - 2. Check the contents of kit before commencing fitment and report any discrepancies.
 - 3. Place these instructions in the vehicle's glove box after installation is complete.
 - 4. These instructions must be followed for warranty to be upheld.



Maximum carrying capacity: 80kg (176lbs) evenly distributed over crossbars.

See below for offroad rating.

Advisory:

It is essential that all bolt connections be checked after 48hrs from when you first install your crossbars. Bolt connections should be checked again at regular intervals (probably once a week is enough, depending on road conditions, usage, loads and distances travelled). You should also check the crossbars each time they are refitted. Make sure to fasten your load securely (see page 2 for advisory diagrams). Please ensure that all loads are evenly distributed and that the centre of gravity is kept as low as possible.

Use only non-stretch fastening ropes or straps.

Off Road Load Ratings

When these roof racks are to be used on a vehicle that is driven off sealed roads, the maximum roof load rating should be divided by a safety factor of 1.5. For example $80/1.5 = 53\text{kgs}$.

Caution:

- The handling characteristics of the vehicle changes when you transport a load on the roof. For safety reasons we recommend you exercise extreme care when transporting wind-resistant loads. Special consideration must be taken into account when cornering and braking. **Please remove crossbars when putting vehicle through an automatic car wash.**

Note for Dealers and Fitters: It is your responsibility to ensure instructions are given to the end user or client.



Toyota Fortuner SX046



Be careful of strong winds.

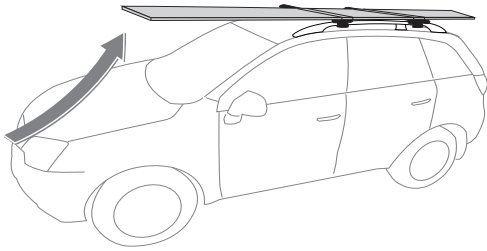

Secure long loads.

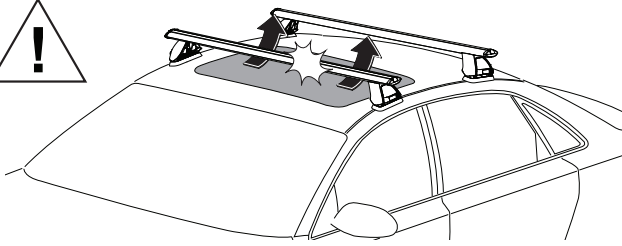
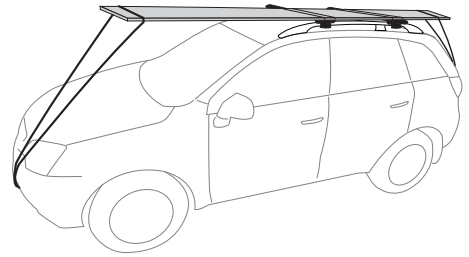
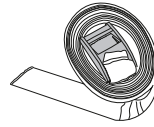

Wash Car by hand.

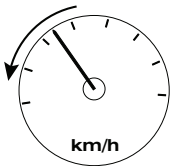
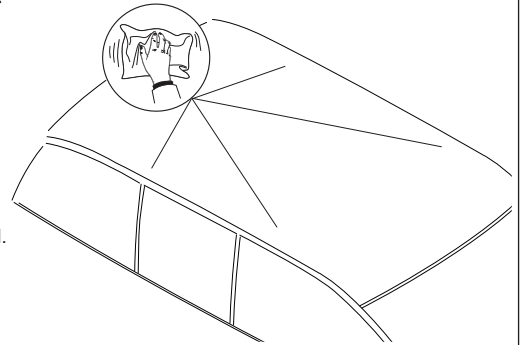

km/h

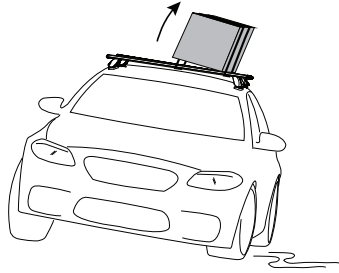

Reduce speeds.

Do not use car wash with racks installed.

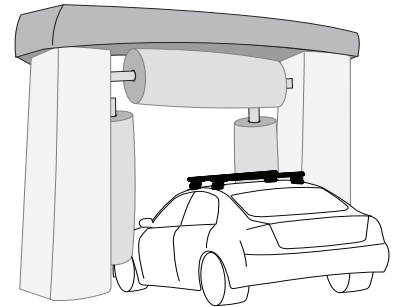

Ensure Ladder is well supported on the ground to help support tent. Take extreme caution when climbing heights above 1.2m/4ft.

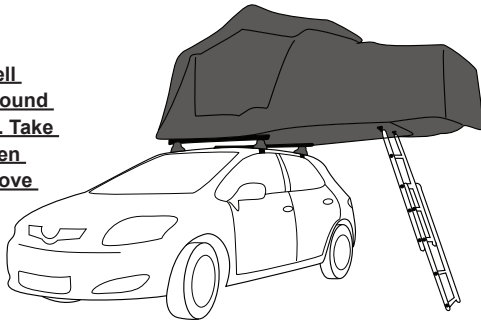

Warning! Important Load Carrying Instructions 80kg (176lbs) evenly distributed over crossbars

When these roof racks are to be used on a vehicle that is driven off sealed roads, the maximum roof load rating (80kg / 176lbs) should be **divided by 1.5**. Do not forget to subtract 5kg/11lbs from your maximum carrying capacity due to the weight of the crossbars and legs.

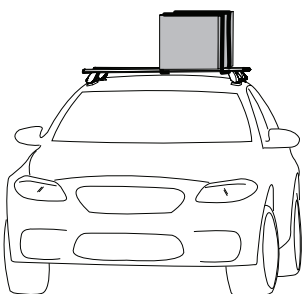

80kg load rating (Urban road) = **53 kg load rating** (Urban / 1.5)

176lbs load rating (Urban road) = **117lbs load rating** (Urban / 1.5)

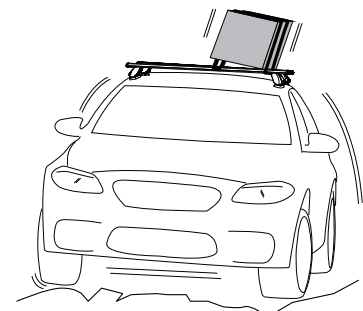



Toyota Fortuner SX046

Parts Required

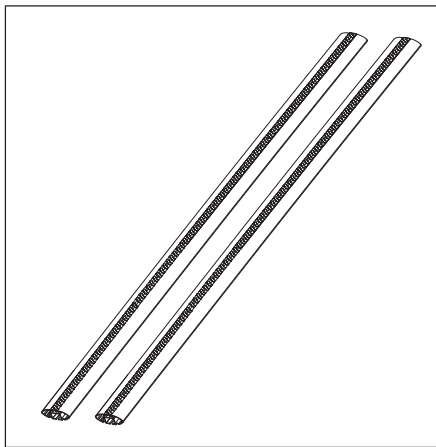

Crossbars
(VA126S, VA126B Sold as separate)

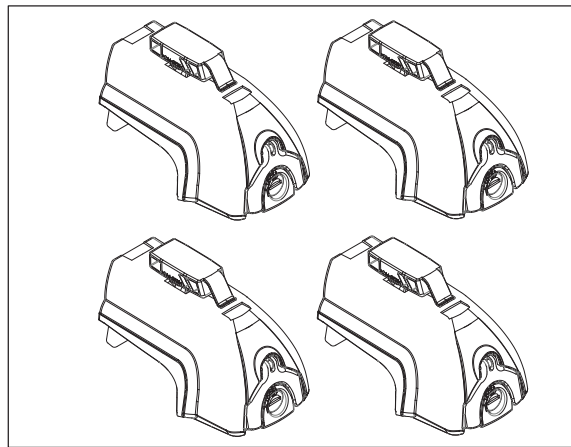

Leg Kit

Parts List

Item	Component Name	Qty	Part No.
1	Leg Unit	4	CA1600
2	Rubber Insert	4	M822
3	Clamp Assembly	4	CA1566
4	Rubber Boot	4	M715
5	Outer Clamp	4	CA1507
6	Dowel Nut	4	N071
7	Adjustment Rod	4	SP222
8	Metal Key	2	CA1339
9	Instructions	1	R747

Tools Required:

Tape measure.
Scissors. Knife.

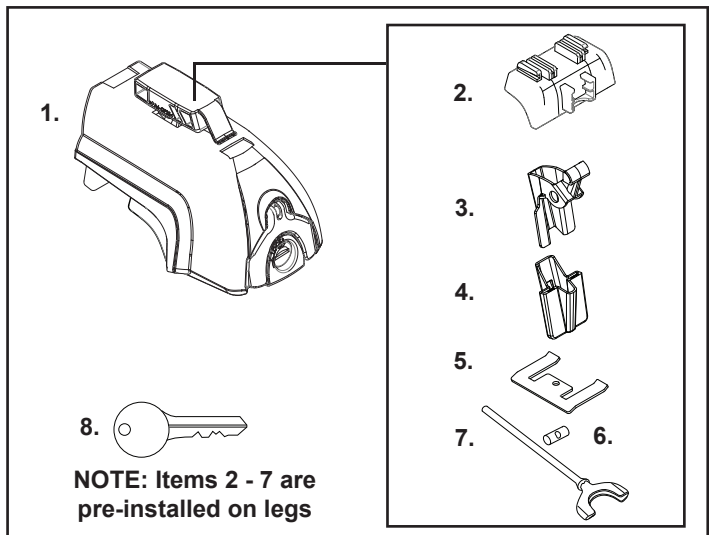

Instructions

1 Open the Crossbar box and remove the contents. Shake the crossbar up and down to remove measurement strips and rubber buffer strips. Crossbars sold separate.

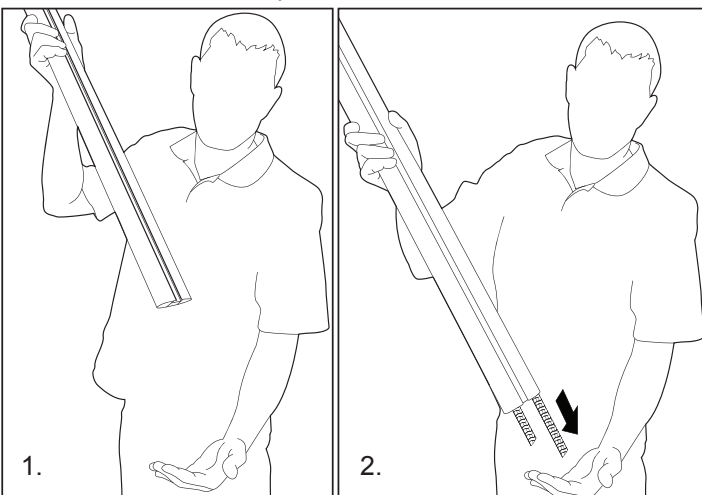

2 Install the Rubber Buffer Strips. Cut to size if required.

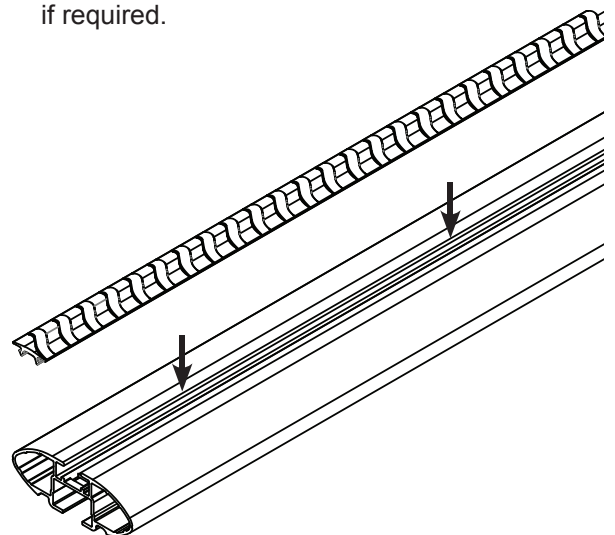



Toyota Fortuner SX046

3 Prepare the Legs for installation into the crossbars.

Unlock the unit as shown.

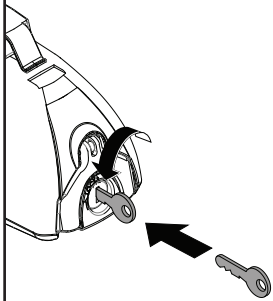

Tighten or loosen the Clamp as required to create a visible gap.

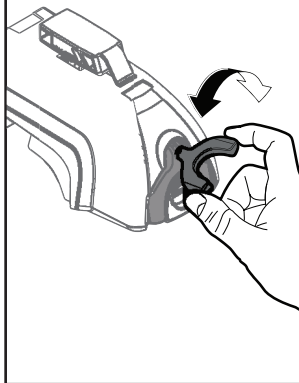

Make sure Metal Clamp Upper is pushed up into housing before inserting into Crossbar.

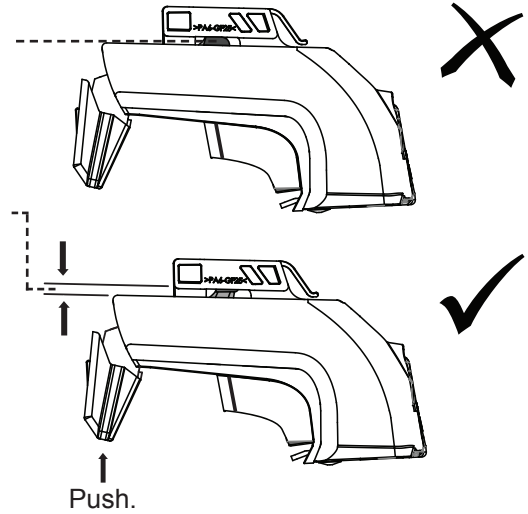

4 1: Slide the Leg Insert into the crossbar as shown. Complete for all four Legs.

2: Insert the Crossbar End Caps, do not lock at this stage. This is for protection during assembly.

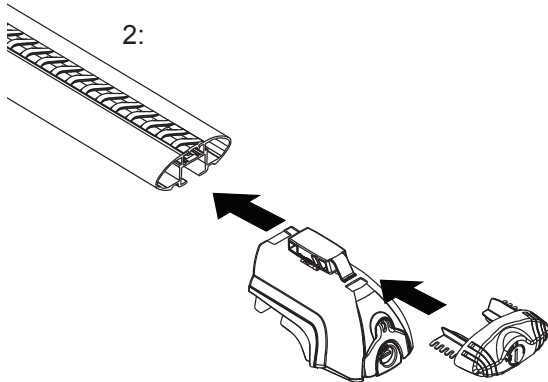

1:

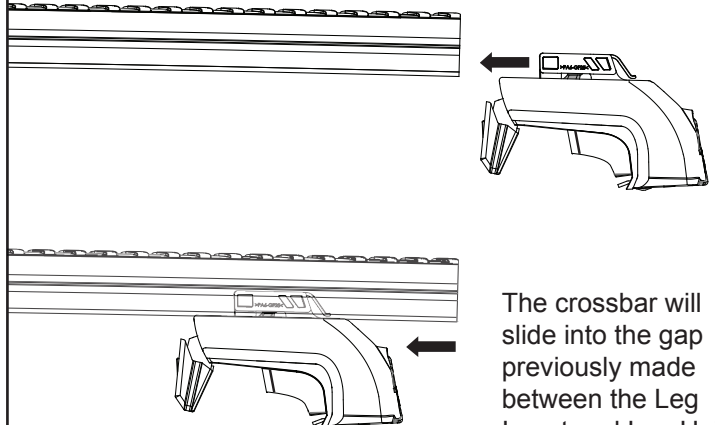

5 Place the front and rear crossbars onto the vehicle. (Refer to step 5b for crossbar locations).

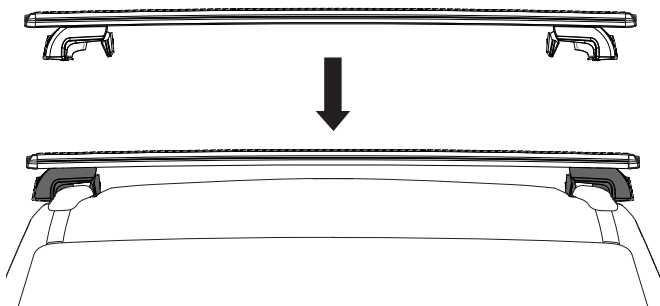

Front View

6 Measure from the end of the crossbar to the rear of the Leg on both sides. Adjust so both measurements are even.

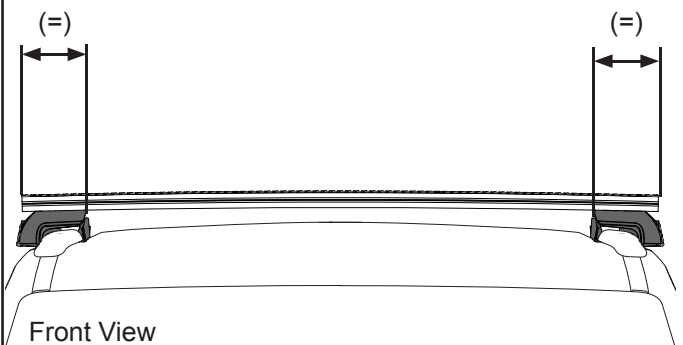

Front View



Toyota Fortuner SX046

- 7** It is recommended to space bars 700mm-800mm apart.
Note: Fortuner has location points in the rail. These are not used in SX046.

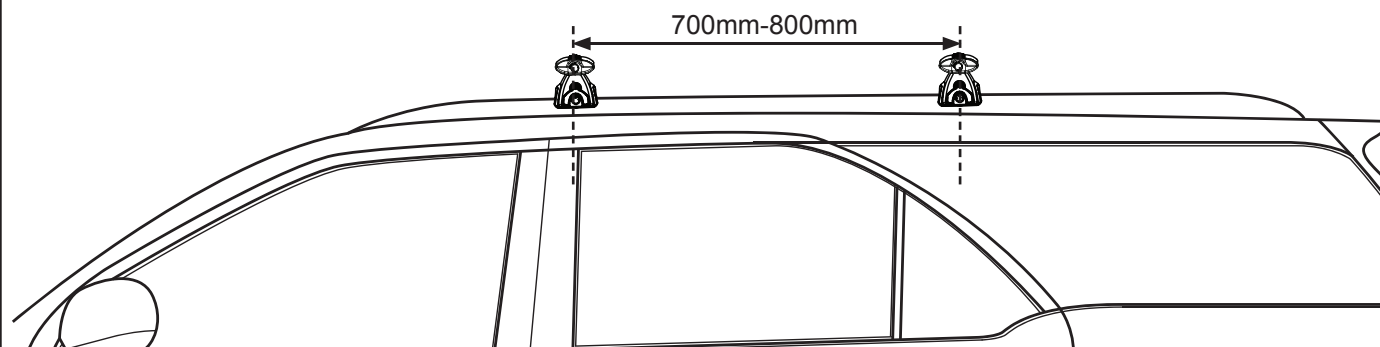

- 8** **1: Note - The Crossbar utilises a tight fit. Downward force is required to fix the leg in place, it is recommended to use additional help.** 2: The Rubber Insert must be in contact with the rail completely along its surface. The Outer Clamp must be gripping on the underside of the rail and the Clamp Assembly should be gripping the inside of the rail as shown. With the Crossbar in place tighten the Legs. Be sure the Leg is sitting snug with the factory rail. **Tightening the Adjustment Rod requires some force.**

Apply downward force.
Crossbar is a tight fit.

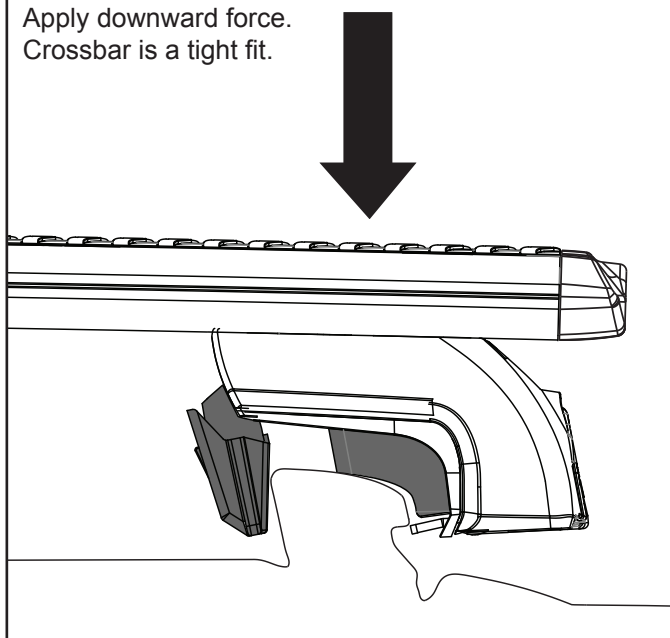

Continue to apply pressure downward. Tighten the Leg in place.

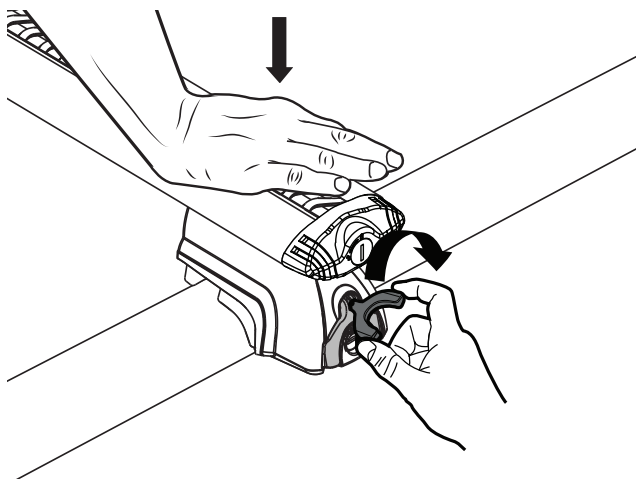

Be sure End Cap is in place before tightening. This will ensure any sharp edges of Crossbar are covered.

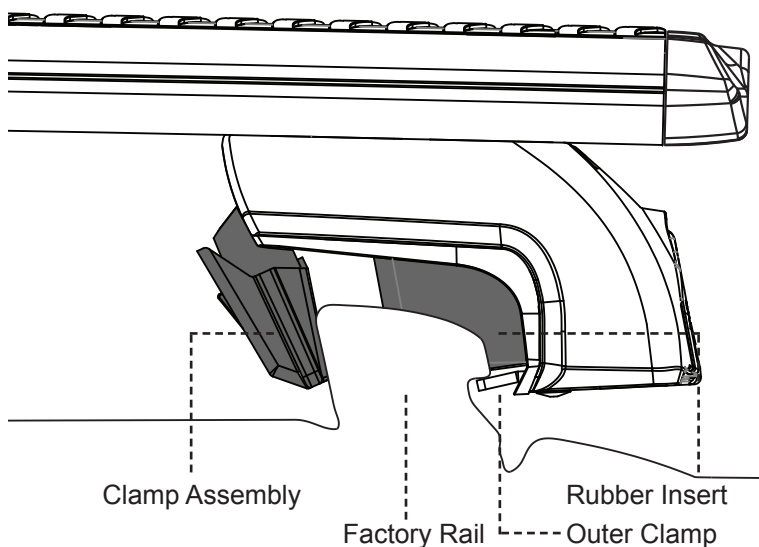



Toyota Fortuner SX046

9 Remove the End Caps. Carefully cut Underbar Strips to fit slots.

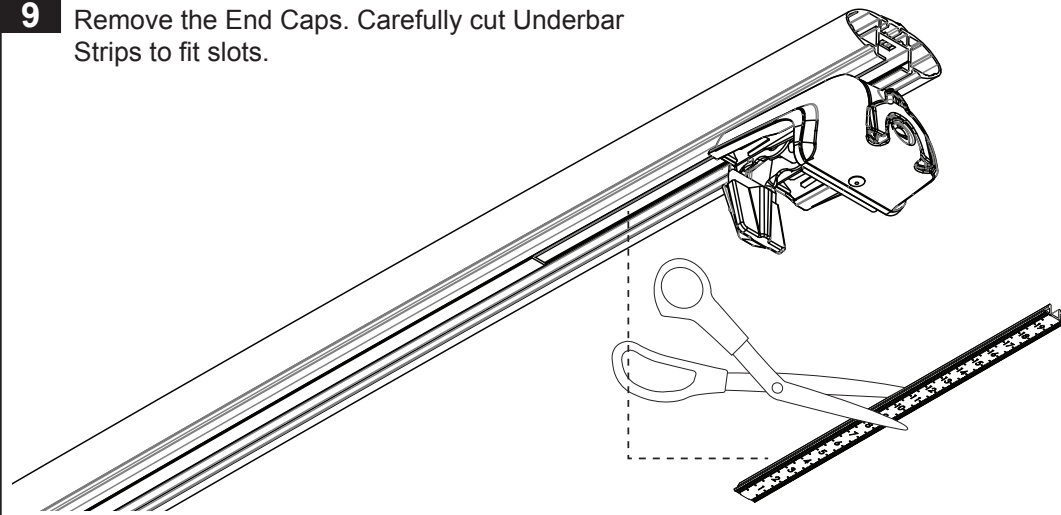

10 With the Underbar Strips cut to the required lengths, install them into the Crossbars. 1: Slide one end into the place behind the Leg. 2: Push the Underbar Strip up and into place along its length. 3: Be sure Strip is secure.

1:

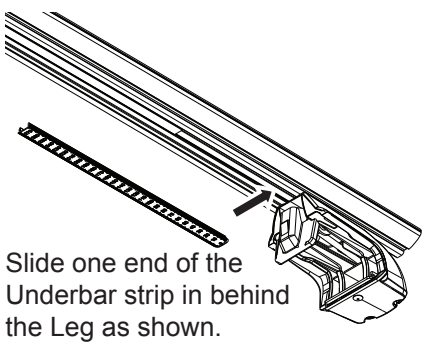

Slide one end of the Underbar strip in behind the Leg as shown.

2:

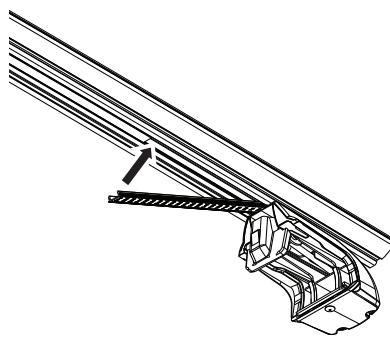

3:

Be sure the strip is fully located along its length.

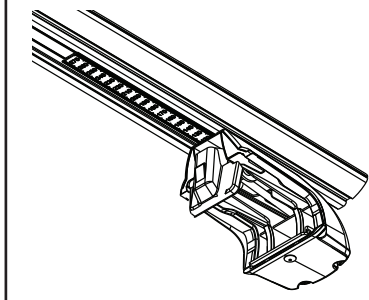

11 Now slide in remaining underbar strip into the outer slot and trim off flush using a knife.

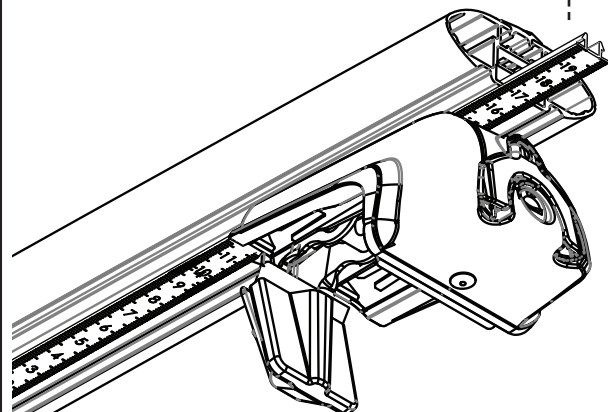
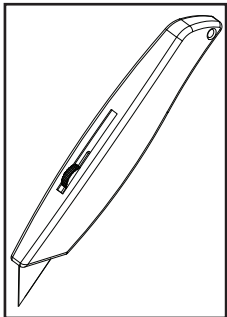

12 Insert End Caps. Be sure all fittings are secure before use.

Insert End Cap and Lock with Key Provided.

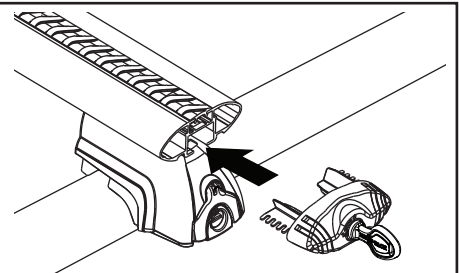

Insert Metal Key and Lock Leg. Remove Key.

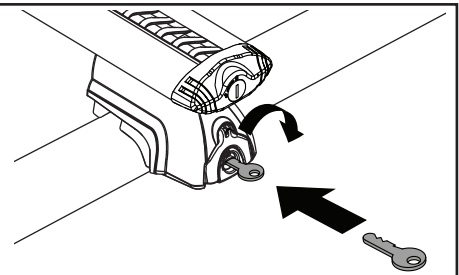

Check Crossbars are secure.

