

RHINO-RACK

RLTFMS - Rhino Crossbar System

MERCEDES-BENZ Sprinter, VOLKSWAGEN Crafter, DODGE Sprinter.

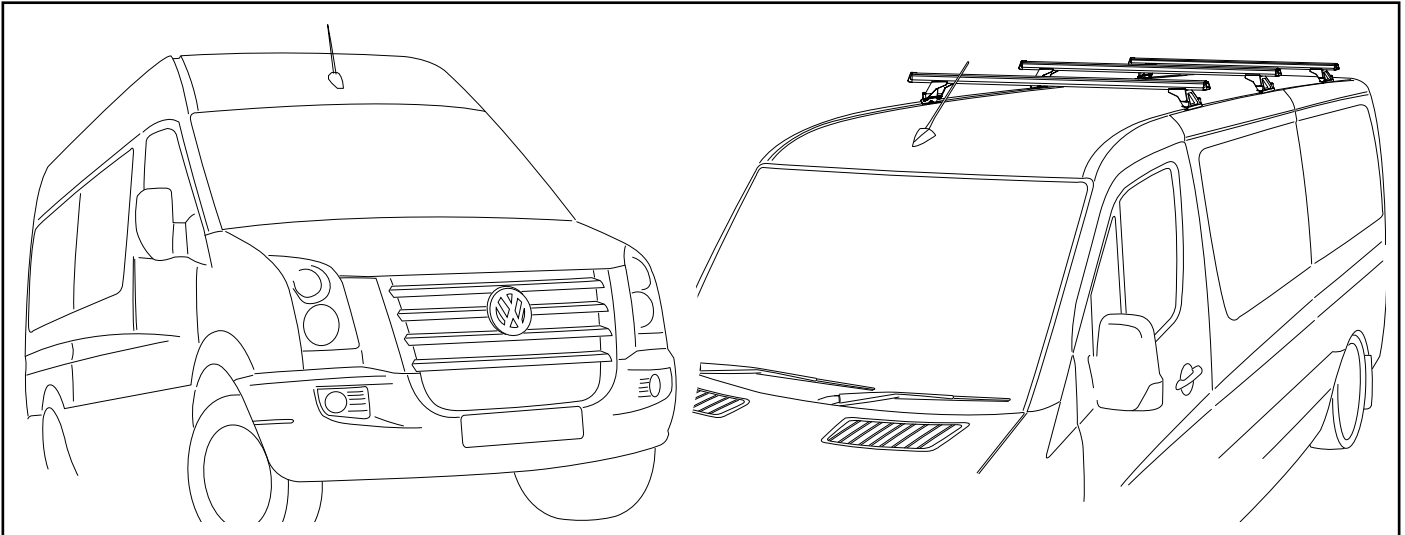

Care Instruction: Wash vehicle roof especially the mounting points prior to installation.

Important Information

1. Check Part No./Kit is correct
2. Read through instruction before installing
3. Fit roof rack accessory
4. Check and recheck all fasteners are secure

Maximum carrying capacity: Two crossbars 100kg (220lbs) including the weight of the rack system 5kg (11lbs). Three or more crossbars 120kg (264lbs) including the weight of the rack system 2.5kg (5.5lbs) per individual crossbar set.

Please refer to your vehicle manufacturers handbook for maximum carrying capacity. Always use the lower of the two figures. Load must be evenly distributed over all crossbars.

Warning: Do not attempt to fit the roof rack system to your vehicle unless you fully understand these fitting instructions. Please direct any questions regarding fitting to the dealer from where the roof racks were purchased.

USE ONLY NON-STRETCH FASTENING ROPES OR STRAPS TO SECURE LOADS.

Recommendations: It is essential that all bolt connections be checked after driving a short distance when you first install your roof racks. Bolt connections should be checked again at regular intervals (once a week is enough, depending on road conditions, usage, loads and distances travelled). You should also check the roof racks each time they are re-fitted. Always make sure to fasten your load securely. Please also ensure that all loads are evenly distributed and that the centre of gravity is kept as low as possible and must be entirely contained within the extents of the roof racks.

Caution: The handling characteristics of the vehicle changes when you transport a load on the roof. For safety reasons we recommend you exercise extreme care when transporting wind-resistant loads. Special consideration must be taken into account when cornering and braking.

Off-road use:

The Roof Rack System may be used in off road applications, however a safety factor of 1.5 is enforced. That is, maximum permissible off road load is **66kg (145lbs)**. Although the crossbars are tested and approved to AS1235-2000, off-road conditions can be much more rigorous. Increasing the number of crossbars does not increase the vehicles maximum permissible roof loading.

Note for Dealers and Fitters:

It is your responsibility to ensure these fitting instructions are given to the end user or client.



RLTFMS - Mercedes-Benz Sprinter, Volkswagen Crafter, Dodge Sprinter

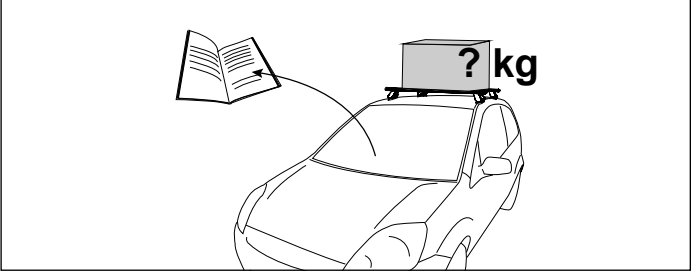
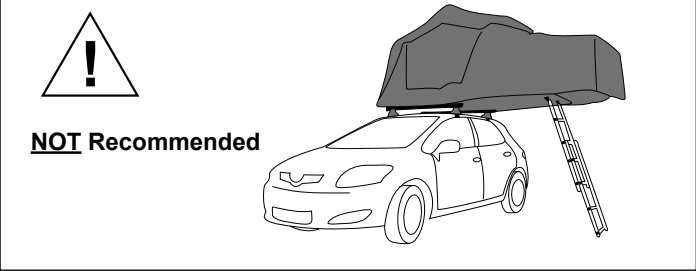
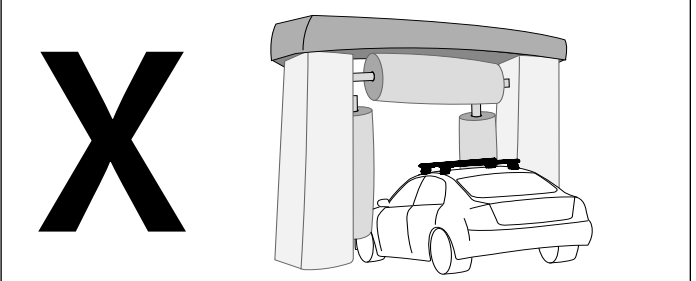
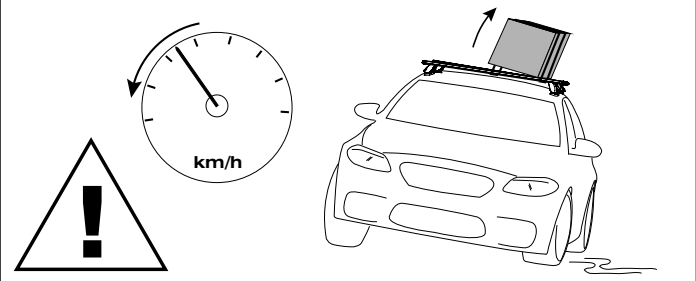
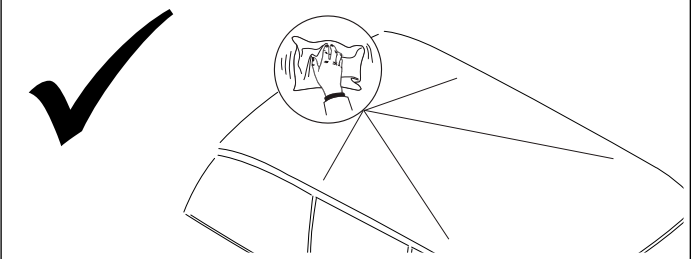
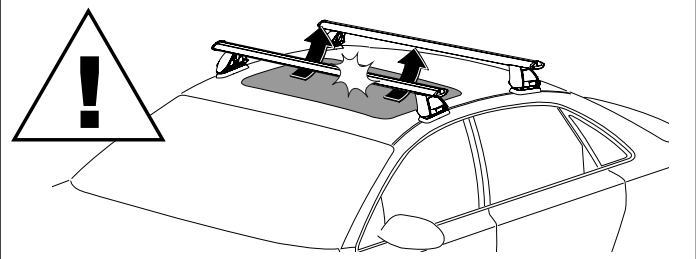
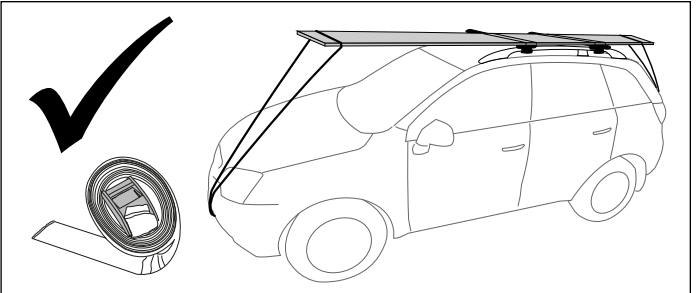
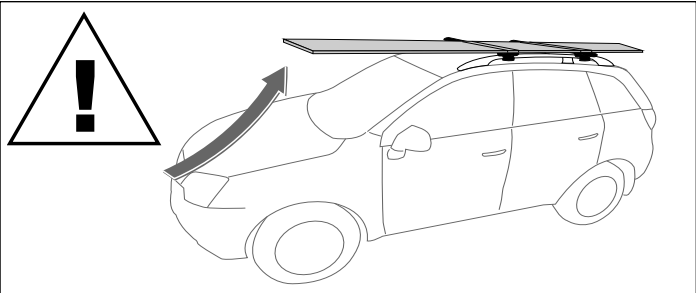

When these roof racks are to be used on a vehicle that is driven off sealed roads, the maximum roof rack load rating should be **divided by 1.5**. Remember to subtract the weight of each crossbar/ leg set (2.5kg) from your maximum carrying capacity due to the weight of the crossbars and legs.

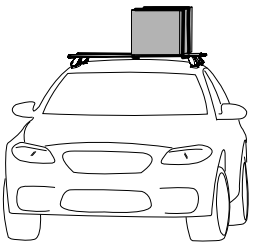

100kg load rating (Urban road) = **66kg load rating** (Off road - 66kg)

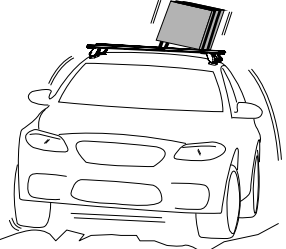

WARNING! Important Load Carrying Instructions

With utility vehicles, the cabin and the canopy move independently. Roof racks and vehicle can be damaged if the item transported is rigidly fixed at points on both the cabin and canopy. Instead, rigidly fix to either the cabin roof racks or the canopy roof racks.

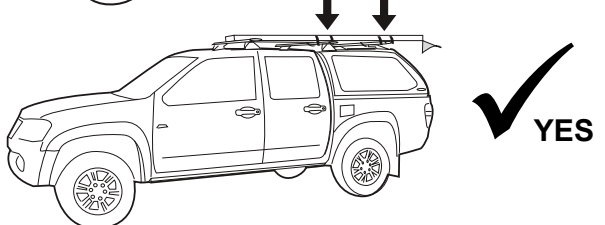
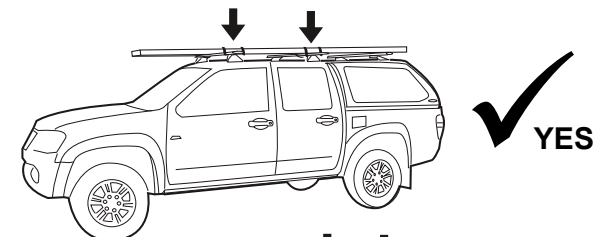
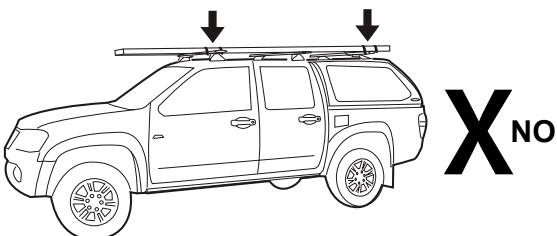



RLTFMS - Mercedes-Benz Sprinter, Volkswagen Crafter, Dodge Sprinter

Parts List

Item	Component Name	Qty	Part No.
1	M10 Channel Nut	2	N024
2	RLTF Leg	2	M010
3	M6 x 35mm Security Screw	4	B092
4	M6 Spring Washer	4	W004
5	M6 x 12.5mm Flat Washer	4	W003
6	M10 x 38mm Flat Washer	2	W022
7	M10 Internal Shakeproof Washer	2	W021
8	M10 x 25mm Hex Bolt	2	B071
9	RLTFMS Bracket	2	C524
10	M8 Nyloc Nut	2	N028
11	M8 Flat Washer	4	W030
12	Foam & Copper Washer	2	C372
13	M8 x 20mm Button Head Screw	2	B155
14	5mm Security Allen Key	1	H021
15	Fitting Instruction	1	RR-148

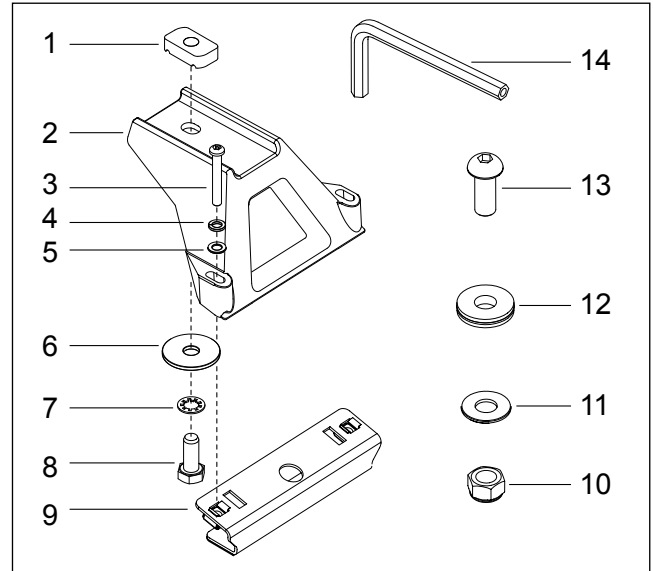

Tools Required:

5mm Security Allen key, provided in kit.
16mm Spanner.
Rubber Mallet.

Tape Measure.
Butyl Mastic Sealant.
Caulking Gun



Heavy Duty crossbar



Vortex crossbar

Crossbars sold individually	Part No.
1650mm Heavy Duty Crossbar SILVER	RB1650S
1650mm Heavy Duty Crossbar BLACK	RB1650B
1650mm Vortex Crossbar SILVER	VA165S
1650mm Vortex Crossbar BLACK	VA165B
1800mm Heavy Duty Crossbar SILVER	RB1800S
1800mm Heavy Duty Crossbar BLACK	RB1800B
1800mm Vortex Crossbar SILVER	VA180S
1800mm Vortex Crossbar BLACK	VA180B

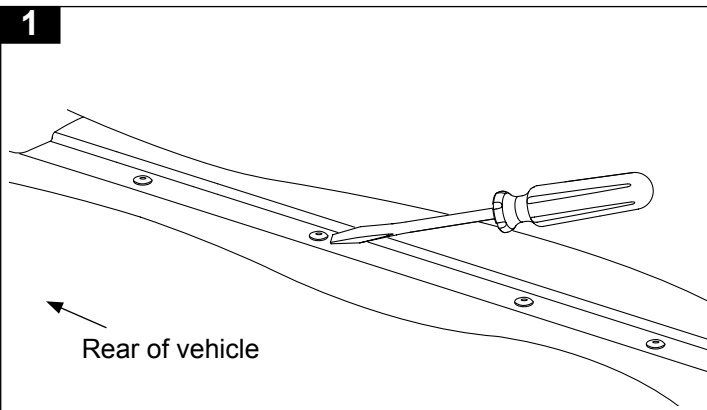

Plastic plugs in the roof channel need to be removed in order to fit the brackets. Only remove plugs from holes that you are going to use. Use a flat head screwdriver from the top to help lever the plugs out or push the plugs out from inside the vehicle. To eliminate rust, be careful not to scratch the paint work.

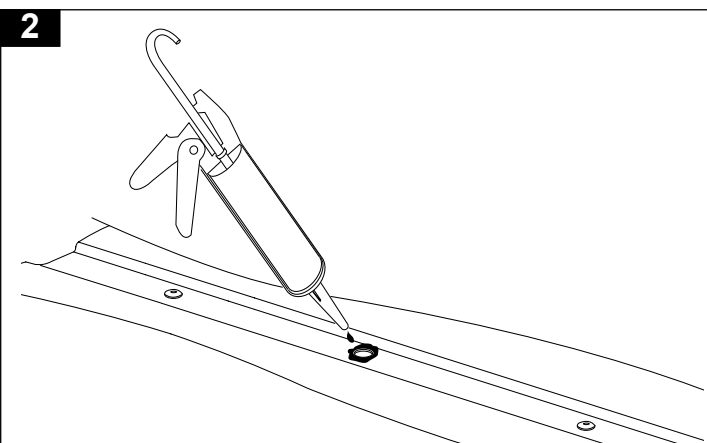

Apply Butyl Mastic sealant in and around the holes you have removed the plugs from to eliminate water leaks.



RLTFMS - Mercedes-Benz Sprinter, Volkswagen Crafter, Dodge Sprinter

3 Place the bracket over the hole. Have the opening of the bracket facing the inside of the vehicle. Refer to diagram below for washer and nut placement. Tighten M8 bolt to 5-6 Nm/ 4-5 lb/ft.

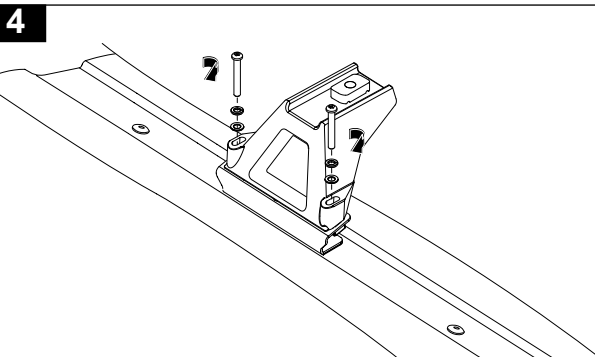
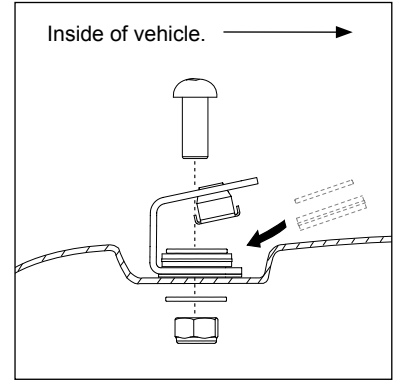
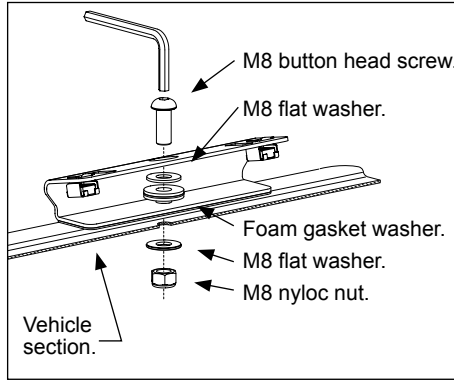
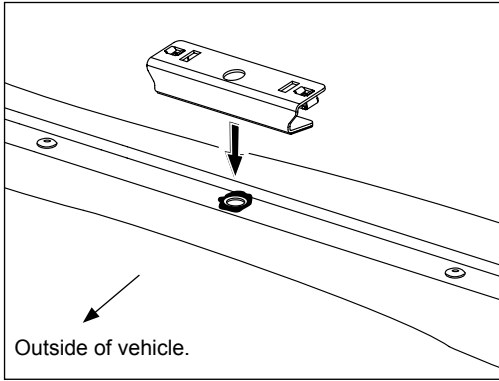

Finger tighten the support leg attachment bolts, as final adjustment and tightening occurs later.

5 Place the crossbar onto the support legs. Push the M10 bolt up and turn the bolt so that the channel nut is located fully across the bar. **Finger tighten the M10 bolts.**

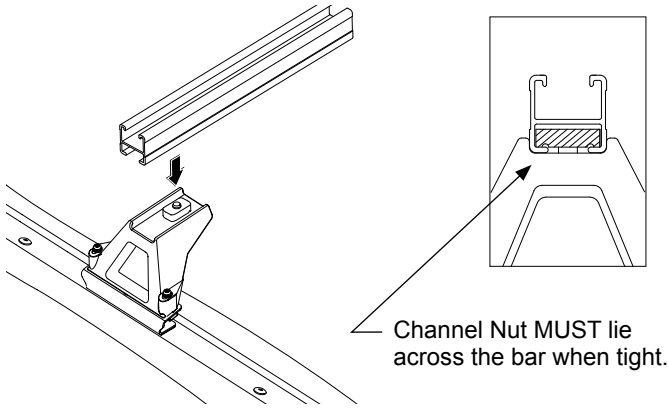

6 On all legs tighten the two M6 Security screws to 3-4 Nm/ 2-3 lb/ft. **DO NOT OVER TIGHTEN.**

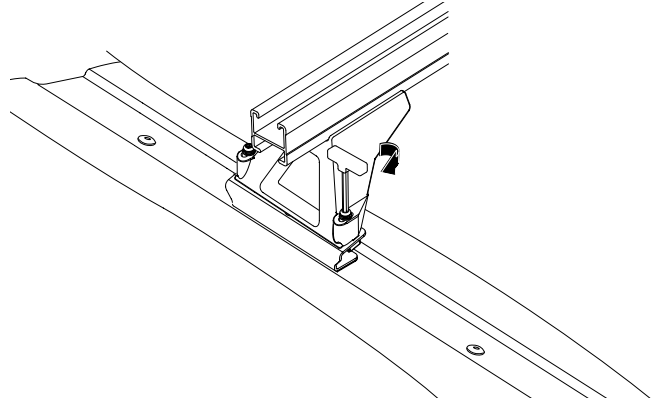

7 Ensure the crossbar overhang (A) is equal on both sides, re-adjust if required. Tighten M10 crossbar attachment bolts to 9-10 Nm/ 6-7 lb/ft. **DO NOT OVER TIGHTEN.**

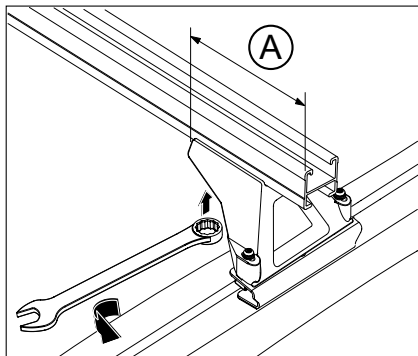

8 Insert the buffer strip into the top of the crossbar, check that the rubber is fully inserted. Fit the end caps into each end of the crossbar, a rubber mallet maybe required to knock in the end caps.

