



RHINO-RACK

Aerodynamic & Heavy Duty Roof Rack Systems

BC2, BC3 & BC4 Rhino Ladders and Utes - K & C Conduit Bracket

Place these instructions in the vehicle's glove box after installation is complete.

Important: Please read these instructions carefully prior to installation. Please refer to your fitting instruction to ensure that the roof racks are installed in the correct locations. Important: Check the contents of kit before commencing fitment and report any discrepancies.

Parts List

Item	Component Name	Qty.			Part No.
		BC2	BC3	BC4	
1	M8 Channel Nut	4	6	8	N003
2	K Bracket	2	3	4	A127
3	C Bracket	4	6	8	A107
4	M8 Shakeproof Washer	4	6	8	W033
5	M8 x 30mm Hex Bolt	2	3	4	B026
6	M8 x 22mm Hex Bolt	4	6	8	B076
7	M8 x 17mm Flat Washer	2	3	4	W020
8	M8 Nyloc Nut	6	9	12	N028
9	Fitting Instruction	1	1	1	RR106

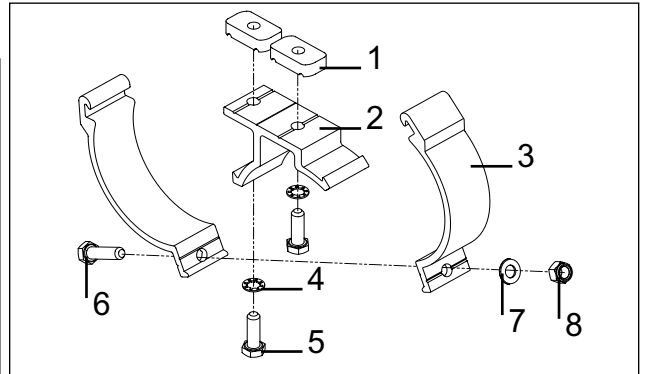

Tools Required

1/2" Spanner

Note:

A & B - Utilise M8 channel nuts.

C - Utilise M8 x 22mm hex bolt which locates into the rail.

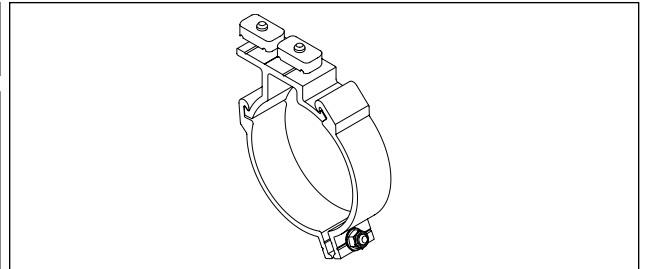

Layout

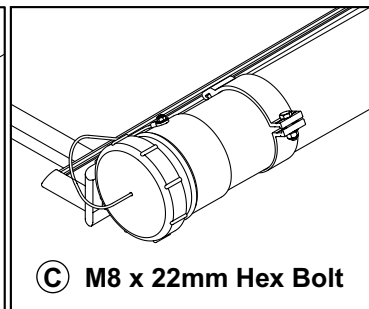
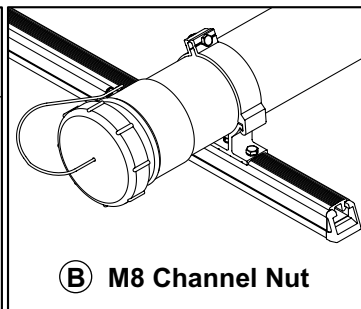
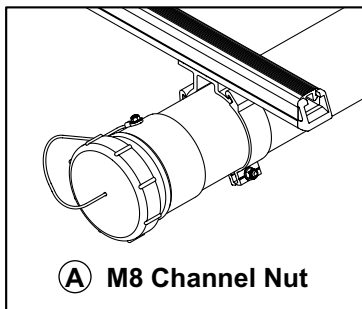

Assemble the bolts, flat washers and channel nuts onto the K bracket.

1

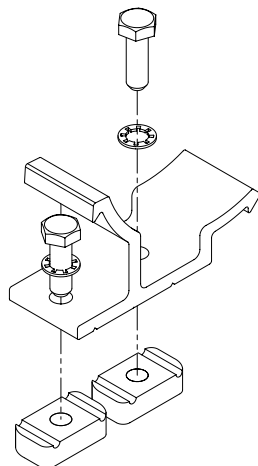

Turn the bolts so that the channel nuts are fully located across the crossbar. Position the K bracket to suit the conduit pipe being used. Tighten the bolts. Check that the channel nuts are fully located across the crossbar after tightening.

2

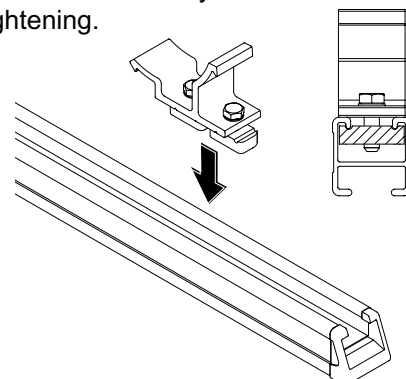

Slide the lower C bracket onto the K bracket.

3

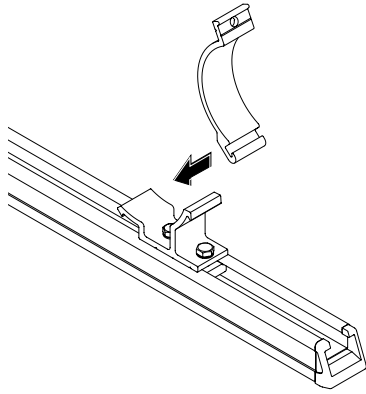

Place the conduit pipe onto the K bracket with lower C bracket resting on the pipe.

4

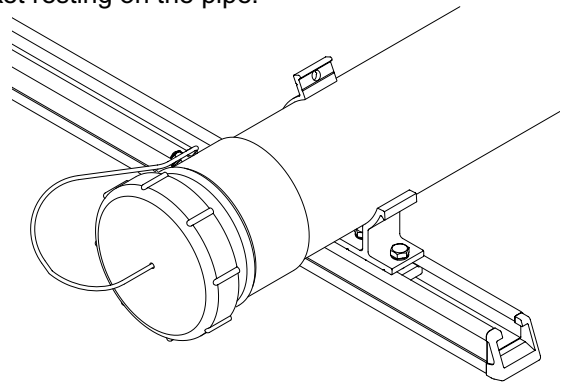

Slide the upper C bracket onto the K bracket.

5

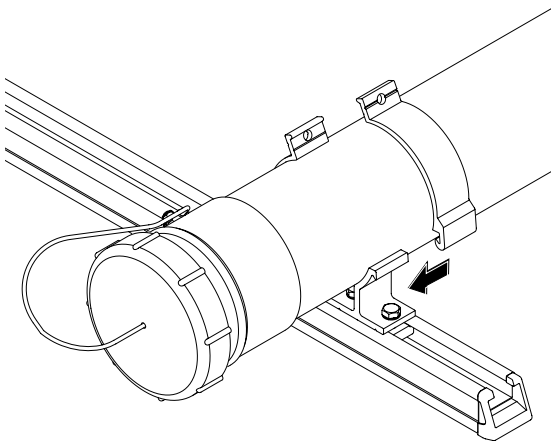

Holding the upper C bracket against the pipe insert the hex bolt flat washer and nyloc nut. Do not fully tighten the nut. Adjust the conduit pipe to suit the multi slide layout. Tighten the clamp bolt. Check that the conduit pipe is secured.

6

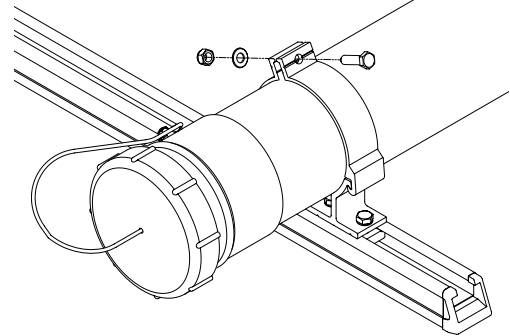

Important Information

RECOMENDATIONS

Please refer to your fitting instruction to ensure that the roof racks are installed in the correct locations. The vehicles roof load rating may be less than the roof rack load rating.

It is essential that all screw/bolt connections are checked after driving a short distance when you first install your roof racks. Screw/bolt connections should be checked again at regular intervals (probably once a week is enough, depending on road conditions, usage, loads and distances travelled). You should also check the roof racks each time they are refitted.

Roof racks and accessories should be cleaned and all screw threads should be lubricated at regular intervals. This will help avoid damage to your vehicles paint surface. Always clean the vehicle roof and the mounting brackets before fitting the roof bars.

Rhino-Rack offers a 3 year warranty to the original purchaser of Rhino-Roof Rack Systems and Accessories. Rhino-Rack cannot be held responsible for incorrect mounting of the roof racks or for usage that exceeds production tolerances.

Make sure to fasten the load securely. Please ensure that all loads are evenly distributed and that the centre of gravity is kept as low as possible.

USE ONLY NON-STRETCH FASTENING ROPES AND STRAPS

SENSITIVITY TO CROSSWINDS, BEHAVIOUR IN CURVES AND BRAKING

The handling of the car changes when you transport a load on the roof.

For safety reasons, we recommend you exercise extreme care when transporting wind resistant loads.

Special consideration must be taken into account when braking.

PLEASE REMOVE ROOF RACKS WHEN PUTTING VEHICLE THROUGH AUTOMATIC CAR WASH

NOTE FOR DEALERS AND FITTERS

It is your responsibility to ensure instructions are given to the end user or supplier.