



RHINO-RACK

Aerodynamic & Heavy Duty Roof Rack Systems

Rhino-Rack Folding Kayak Carrier Extension S512X

Important: Please read these instructions carefully prior to installation. Please refer to your fitting instruction to ensure that the bike rack is installed in the correct locations. Check the contents of kit before commencing fitment and report any discrepancies. Place these instructions in the vehicle's glove box after installation is complete.

Layout

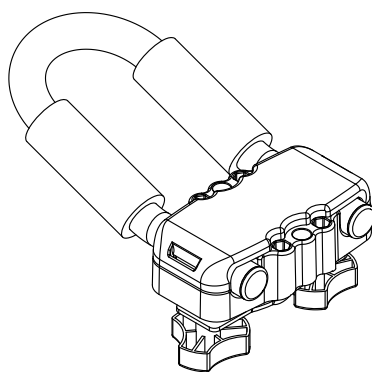

Important Information

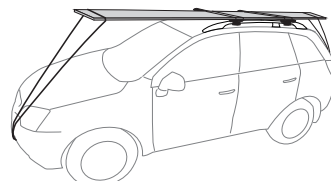
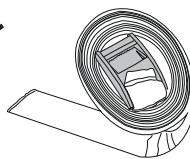
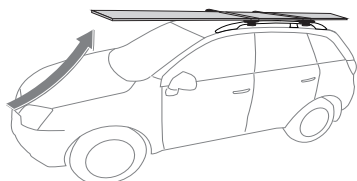

Maximum carrying capacity: 25kg (55lbs)

Please refer to your vehicle manufacturers handbook for maximum carrying capacity of your roof racks. Always use the lower of the two figures. Load must be evenly distributed over the crossbars.

Warning: Do not attempt to fit the S512X to your vehicle unless you fully understand this fitting instructions. Please direct any questions regarding fitting to the dealer from where the S512X was purchased. **Use only non-stretch fastening ropes or straps.**

Recommendations:

It is essential that all bolt connections be checked after driving a short distance when you first install your roof racks and S512X. Bolt connections should be checked again at regular intervals (once a week is enough, depending on road conditions, usage, loads and distances travelled). You should also check the roof racks and S512X each time they are re-fitted. Always make sure to fasten your load securely. Please also ensure that all loads are evenly distributed and that the centre of gravity is kept as low as possible. Long loads (e.g. canoes and kayaks) must be secured front and rear with non-stretch fastening ropes or straps.

Roof racks must be removed when putting vehicle through an automatic car wash.

Caution: The handling characteristics of the vehicle changes when you transport a load on the roof. For safety reasons we recommend you exercise extreme care when transporting wind-resistant loads. Special consideration must be taken into account when cornering and braking.



Rhino-Rack Folding Kayak Carrier Extension S512X

Parts List

Item	Component Name	Qty
1	Kayak Carrier Extension Universal Fitting	2
2	5.5m Tie Down Straps	2
3	3m Covered Buckle Straps	2
4	Fitting Instruction	1

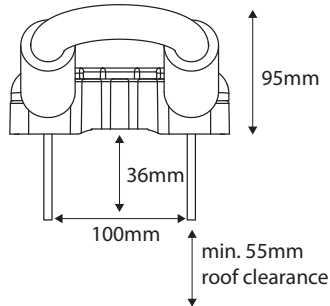

C-channel fitment kit sold separately
 KC - FK8 for Rhino Aero and HD bar
 KC - FK9 for Rola Aero and Rola
 Commercial bar
 KC - FK10 for European bar

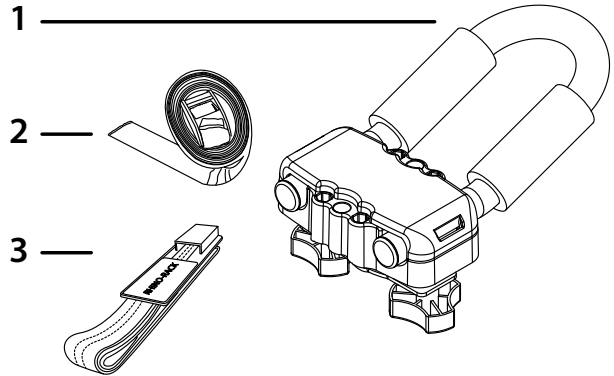

Refer to
C-channel fitment guide

Care Instruction:

Wash and clean vehicle roof racks prior to fitment

1

For Heavy Duty cross bars, you will need the optional C-channel fitment kit.

The fitting instruction for Heavy Duty bar is at step 5.

The kayak loading and strapping instructions in the following pages still apply

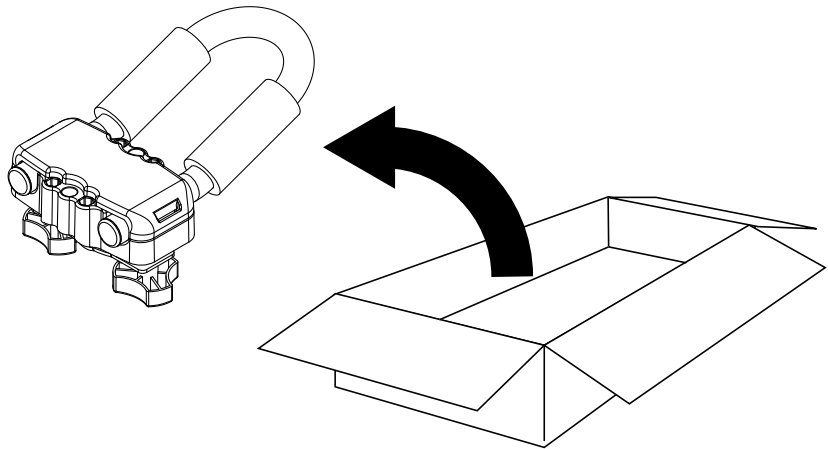

2

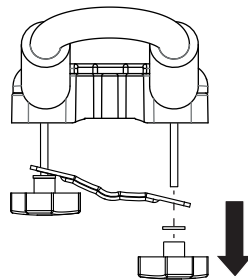
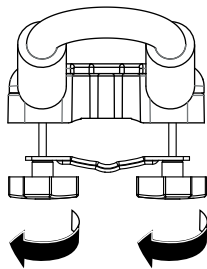

Do not overtighten

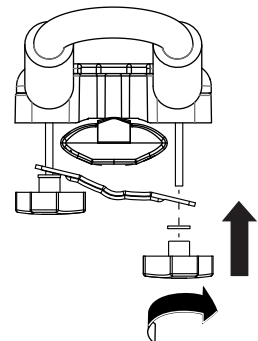

Aero bar shown for fitting instruction purposes



Rhino-Rack Folding Kayak Carrier Extension S512X

3

To use with the Rhino-Rack Folding Kayak Carrier S512 (NOTE: Sold separately)

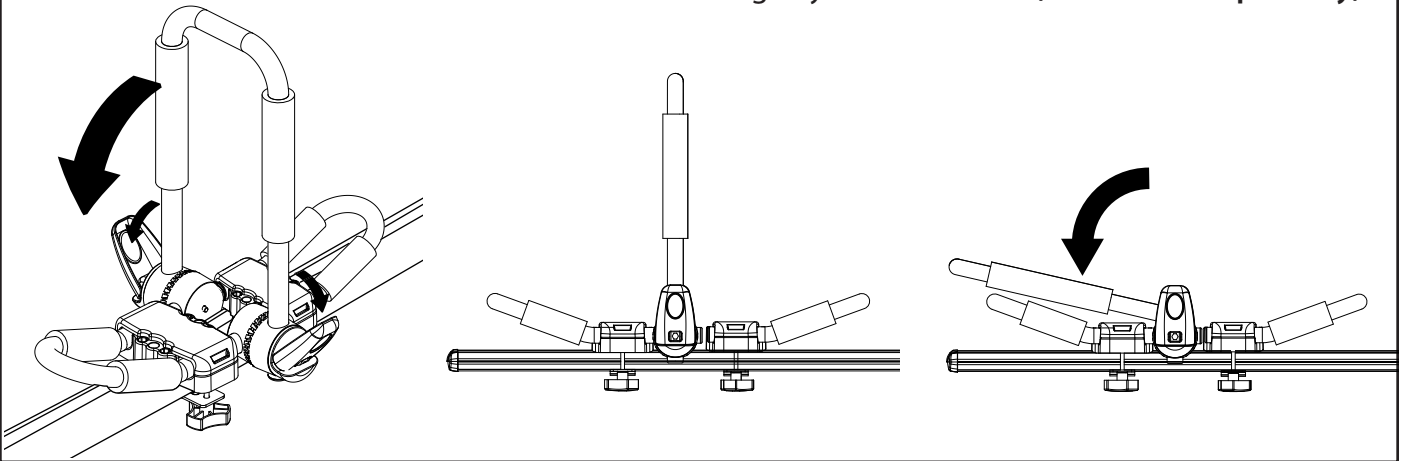

4

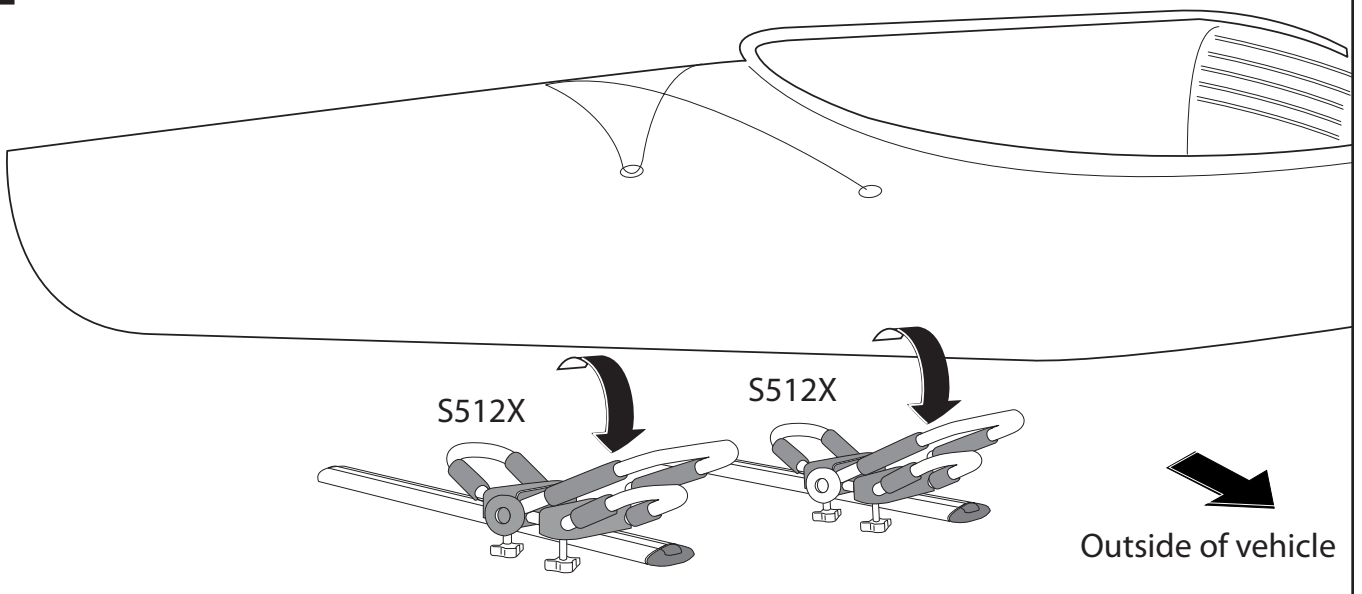

5

Keep the straps loose at this point

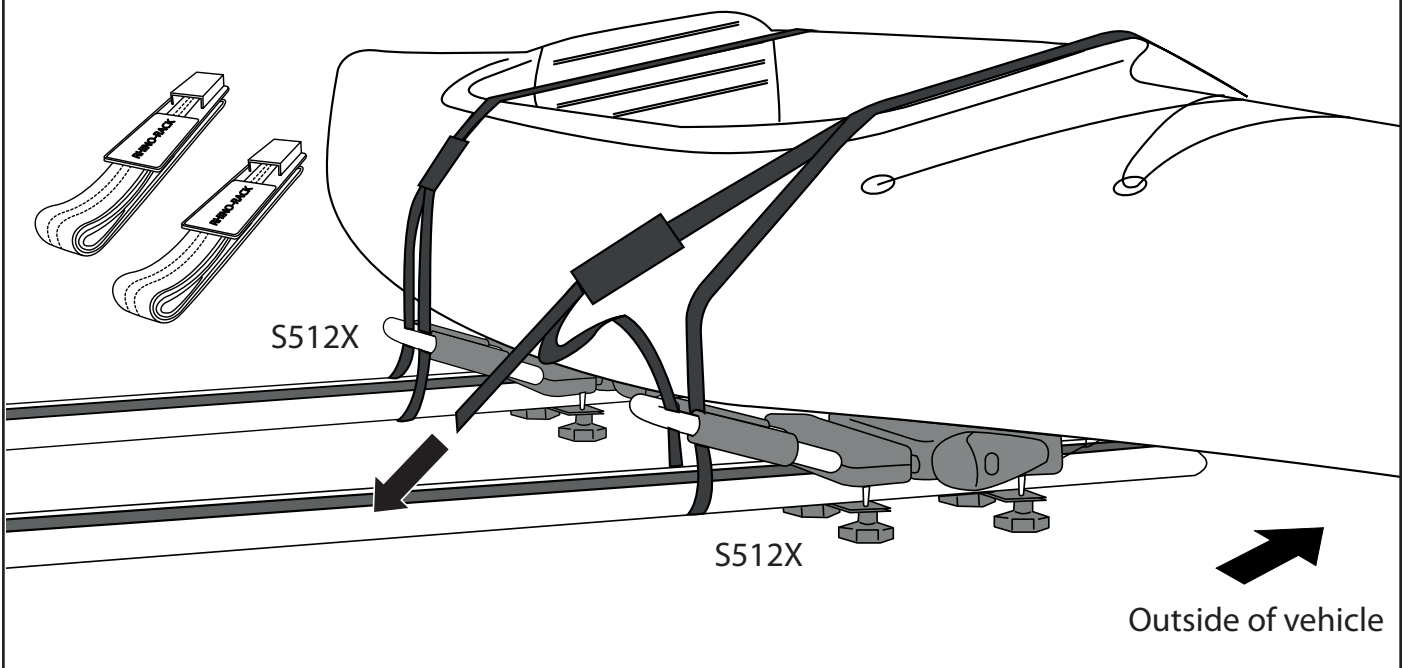



Rhino-Rack Folding Kayak Carrier Extension S512X

- 6** Rotate arm up and lock it in position as shown

Load 2nd canoe / kayak

Repeat steps 3 to 6

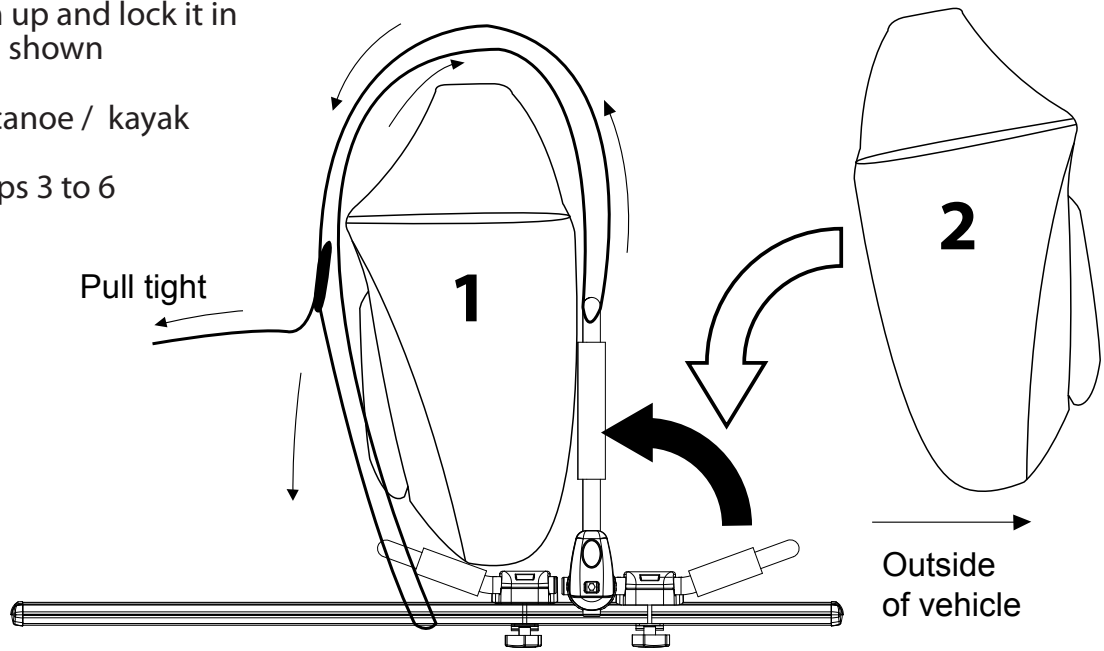

7

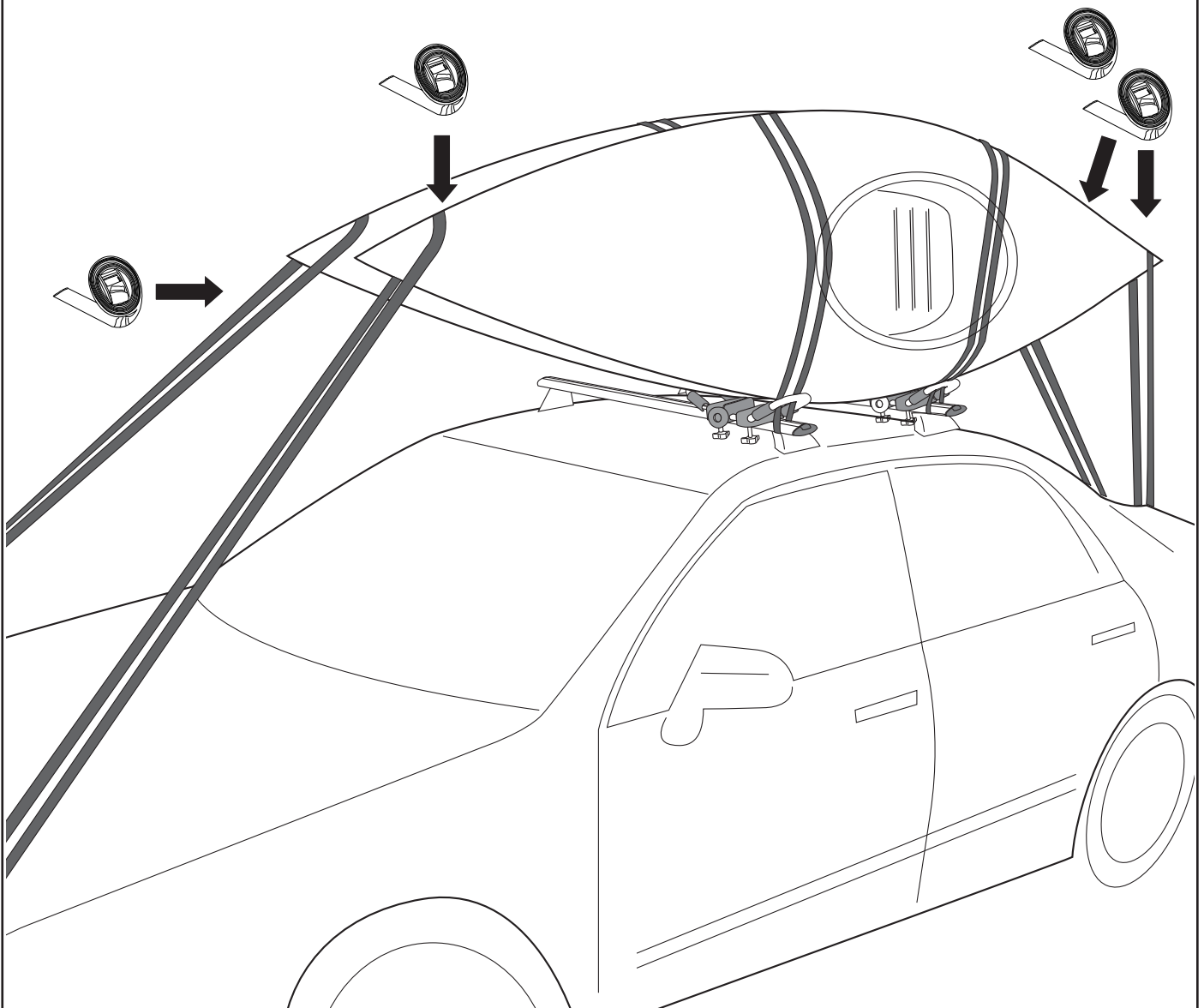



Rhino-Rack Folding Kayak Carrier Extension S512X

How to install and use the optional C- channel installation kit (NOTE: Sold separately)

1

Replace long bolts with supplied 40mm bolt

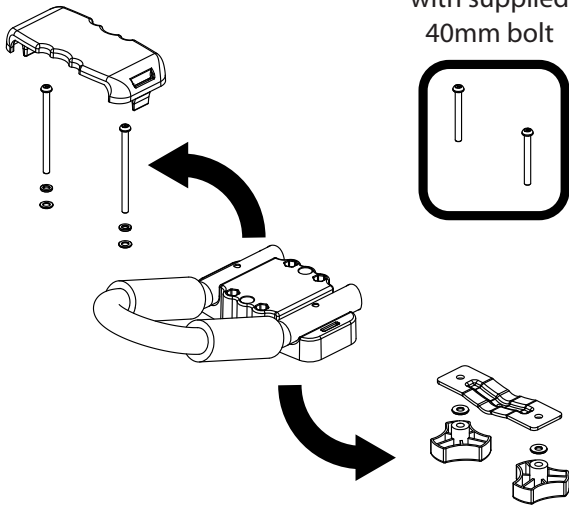

2

Use soapy water on the rubber tabs for inserting cover back in place. Pliers can be used to assist in inserting the rubber cover.

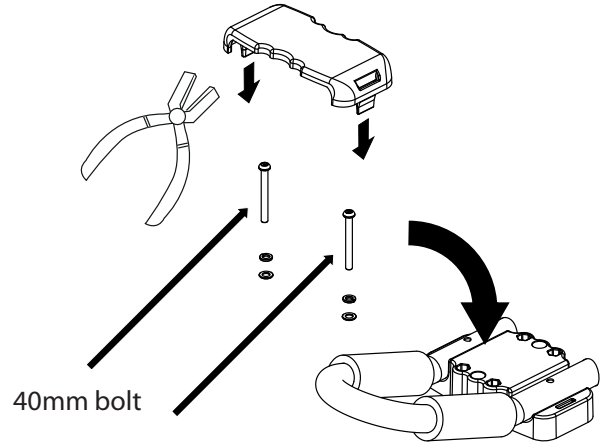

3

The 40mm bolts will not protrude out of the bottom. The carrier is now ready for the C-channel fitment

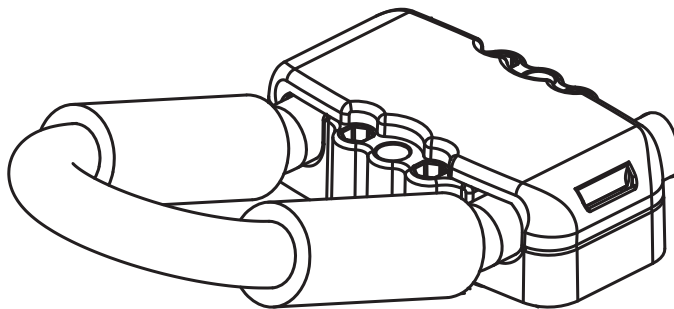

4

RHINO Sportz, RHINO Aero, THULE Rapid & New ROLA Rails bar (PART NO: KC-FK8)

Remove end caps and rubber buffer strip from roof cross bar.

Slide the Nut Plate into the top of the Roof Rack cross bar.

Put the two M6 x 32mm screw and washer assemblies through the middle hole in the base support and fasten to the Nut Plate.

Tighten to 3-4Nm.

M6 x 32

Spring Washer

Flat Washer

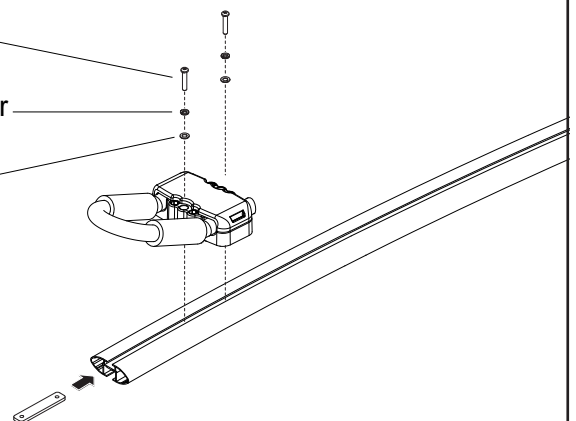



Rhino-Rack Folding Kayak Carrier Extension S512X

5

RHINO Heavy Duty (PART NO: KC-FK8)

Remove rubber buffer strip from Roof Rack cross bar.

Assemble hardware as shown.

Put the two M6 x 40mm screw and washer assemblies through the middle hole in the base support and fasten to the Channel Nuts.

Lock the Channel Nuts into the top of the roof cross bar. Check the Channel Nuts are located correctly.

Tighten to 3-4Nm.

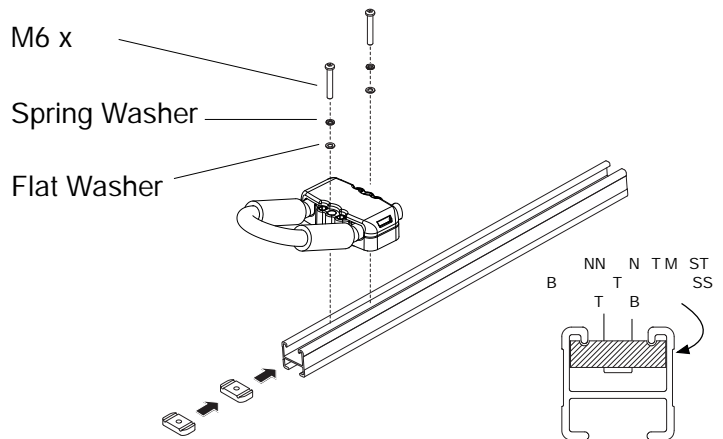

6

EUROPEAN Bars (PART NO: KC-FK10)

With the Kayak Carrier sitting on the Roof Rack bar, place the four M6 x 70mm Hex bolts through the four hexagonal holes in the base support.

Hook the two Lower U Adaptors under the cross bar. Place the M6 x 16 Washers on the Bolts and fasten using the four Plastic Knob Nuts.

Tighten to 3-4Nm.

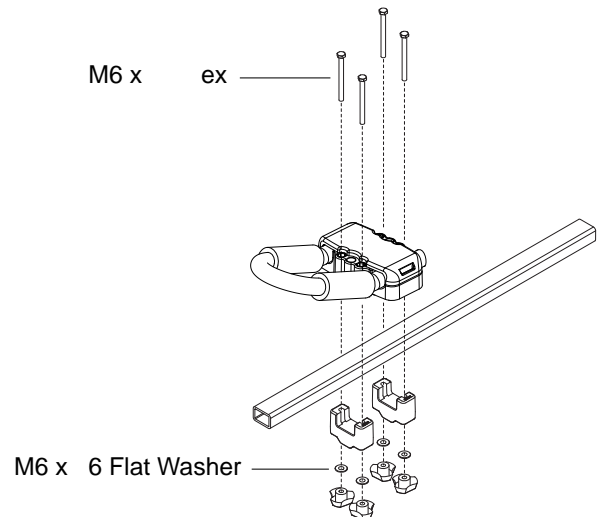

7

Rola Rack & old ROLA Commercial Bar (PART NO: KC-FK9)

Remove end caps and rubber buffer strip from Roof Rack cross bar.

Locate 'T' Bolt into cross bar channel, turn 'T' Bolt. Place Locking tab over 'T' Bolt.

Put the two M6 Tube Nut and washer assemblies through the middle hole in the base support and fasten to the M6 x 35mm T-Bolt.

Tighten to 3-4Nm.

