



RHINO-RACK

Rhino-Rack Folding Kayak Carrier S512

Important: Please read these instructions carefully prior to installation. Please refer to your fitting instruction to ensure that the bike rack is installed in the correct locations. Check the contents of kit before commencing fitment and report any discrepancies. Place these instructions in the vehicle's glove box after installation is complete.

Layout

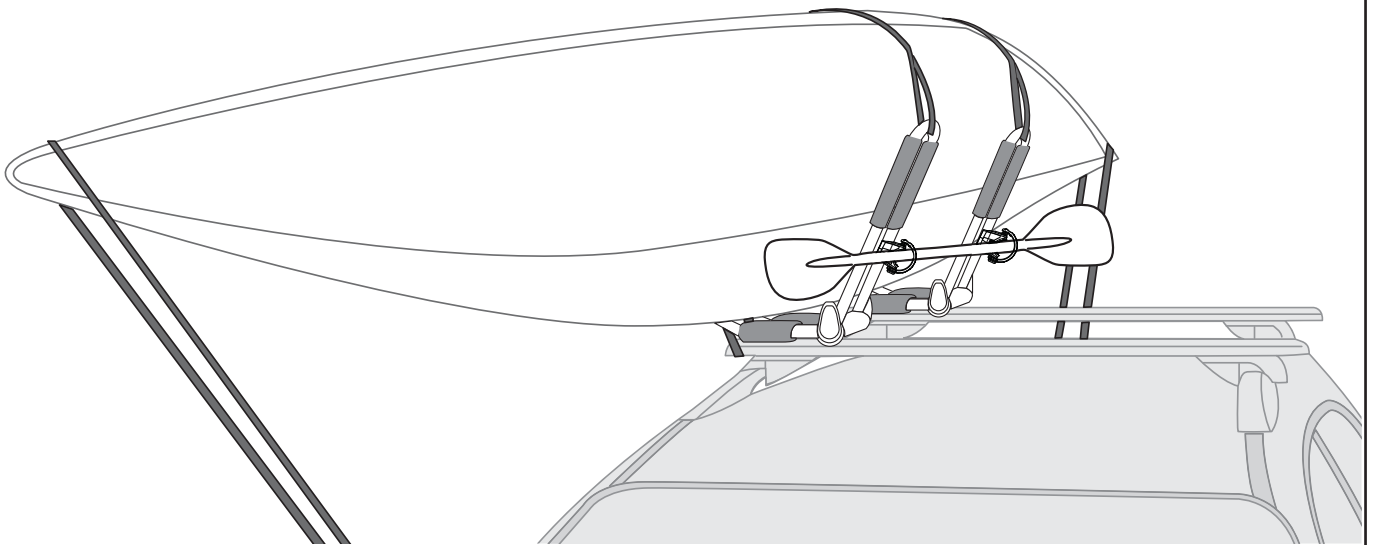

Important Information

Maximum carrying capacity: 25kg (55lbs)

Please refer to your vehicle manufacturers handbook for maximum carrying capacity of your roof racks. Always use the lower of the two figures. Load must be evenly distributed over the crossbars.

Warning: Do not attempt to fit the S512 to your vehicle unless you fully understand this fitting instructions. Please direct any questions regarding fitting to the dealer from where the S512 was purchased. **Use only non-stretch fastening ropes or straps.**

Recommendations:

It is essential that all bolt connections be checked after driving a short distance when you first install your roof racks and S512. Bolt connections should be checked again at regular intervals (once a week is enough, depending on road conditions, usage, loads and distances travelled). You should also check the roof racks and S512 each time they are re-fitted. Always make sure to fasten your load securely. Please also ensure that all loads are evenly distributed and that the centre of gravity is kept as low as possible. Long loads (e.g. canoes and kayaks) must be secured front and rear with non-stretch fastening ropes or straps.

Roof racks must be removed when putting vehicle through an automatic car wash.

Caution: The handling characteristics of the vehicle changes when you transport a load on the roof. For safety reasons we recommend you exercise extreme care when transporting wind-resistant loads. Special consideration must be taken into account when cornering and braking.



Rhino-Rack Folding Kayak Carrier S512

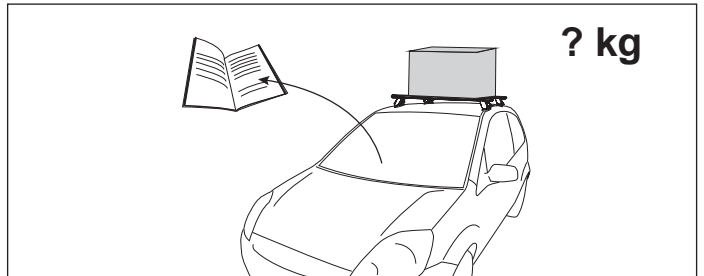
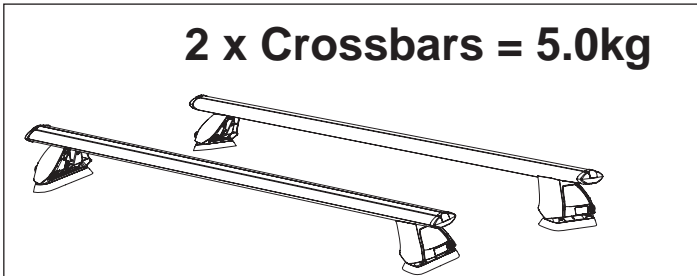
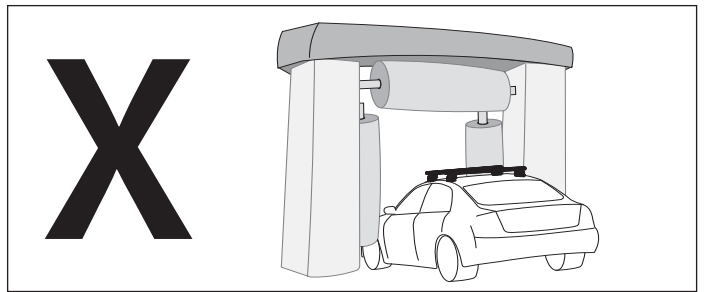
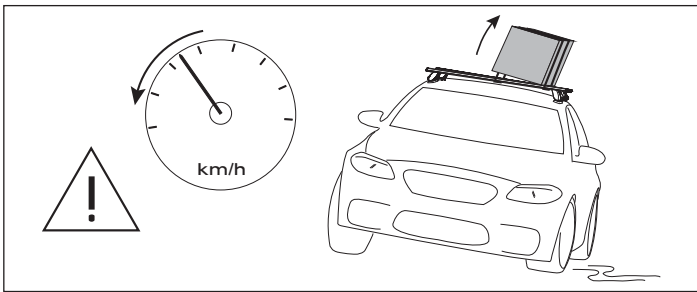
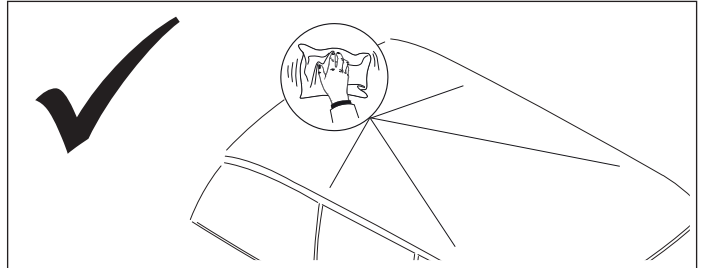
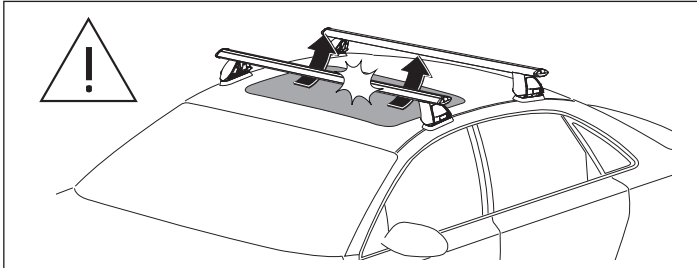
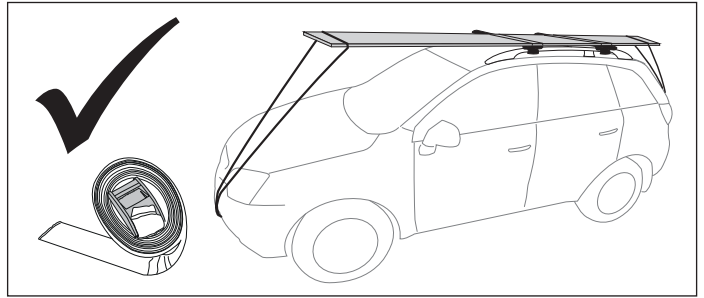
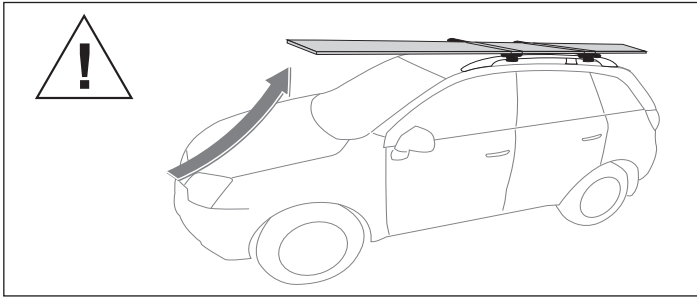

When these roof racks are to be used on a vehicle that is driven off sealed roads, the manufacturer maximum roof load rating (to be found in the vehicles User Manual) should be **halved**. Do not forget to subtract 7.5kg from your maximum carrying capacity due to the weight of the crossbars and legs.

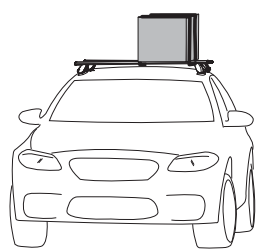

$$60\text{kg load rating (Urban road)} = 30\text{kg load rating (Off road - } 60\text{kg} / 2)$$

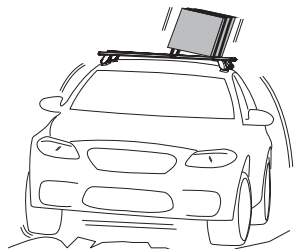

WARNING! Important Load Carrying Instructions

With utility vehicles, the cabin and the canopy move independently. Roof racks and vehicle can be damaged if the item transported is rigidly fixed at points on both the cabin and canopy. Instead, rigidly fix to either the cabin roof racks or the canopy roof racks.

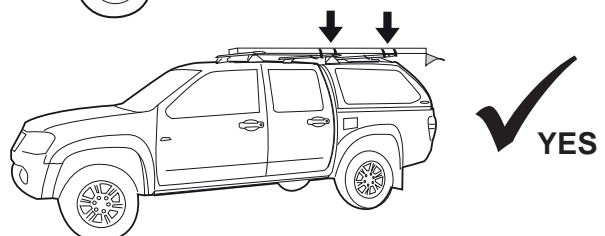
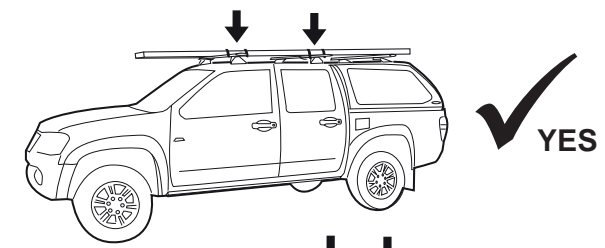
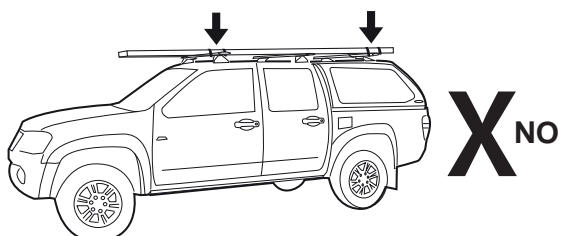



Rhino-Rack Folding Kayak Carrier S512

Parts List

Item	Component Name	Qty
1	Kayak Carrier with Universal Fitting	2
2	5.5m Tie Down Straps	2
3	3m Covered Buckle Straps	2
4	Fitting Instruction	1

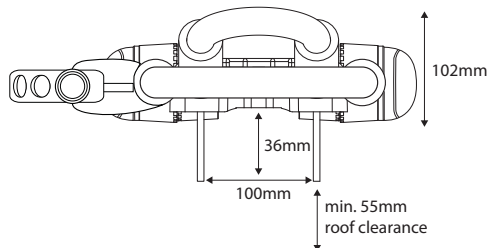

C-channel fitment kit sold separately
 KC - FK8 for Rhino Aero and HD bar
 KC - FK9 for Rola Aero and Rola Commercial bar
 KC - FK10 for European bar

1 _____

2 —

3 —

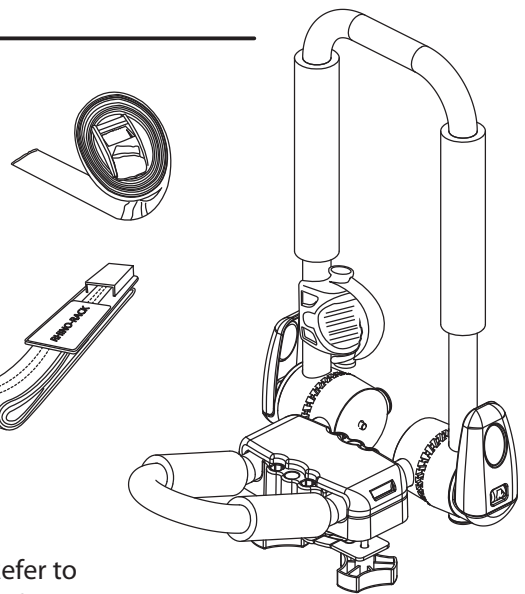

Refer to
C-channel fitment guide

Care Instruction:

Wash and clean vehicle roof racks prior to fitment

1

For Heavy Duty cross bars, you will need the optional C-channel fitment kit.

The fitting instruction for Heavy Duty bar is at step 5. The kayak loading and strapping instructions in the following pages still apply

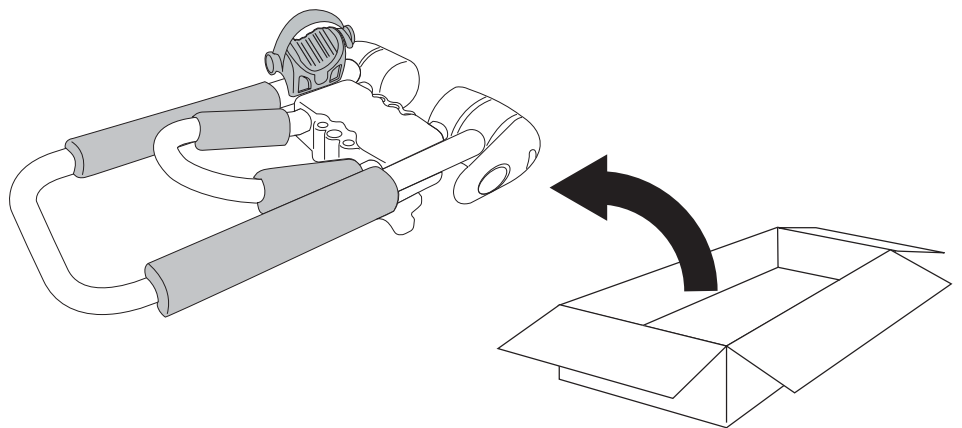

2

Do not overtighten

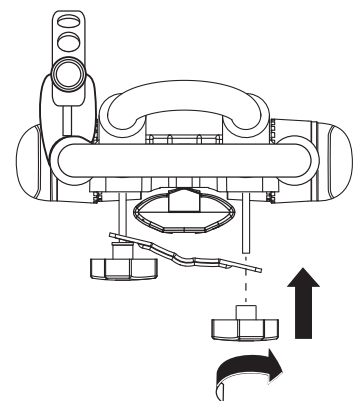
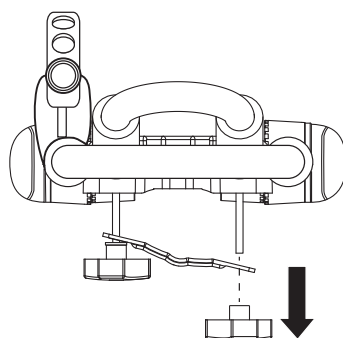
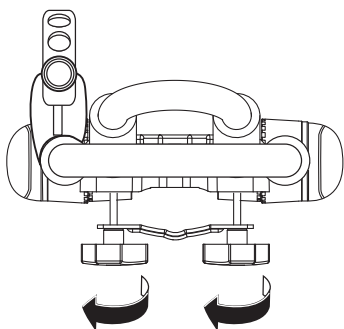

Aero bar shown for fitting instruction purposes



Rhino-Rack Folding Kayak Carrier S512

3 Fold out the cradle

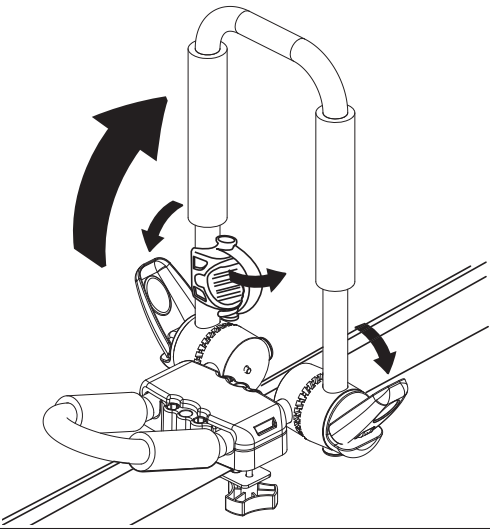

4 Load the paddle

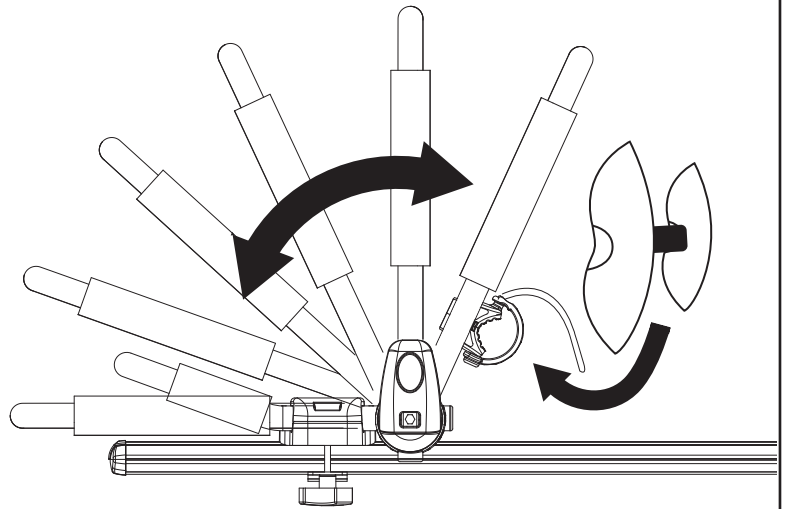

5

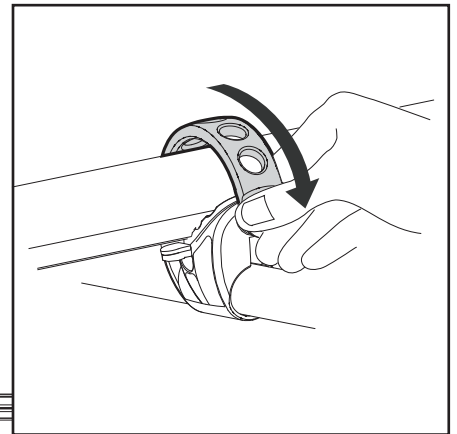
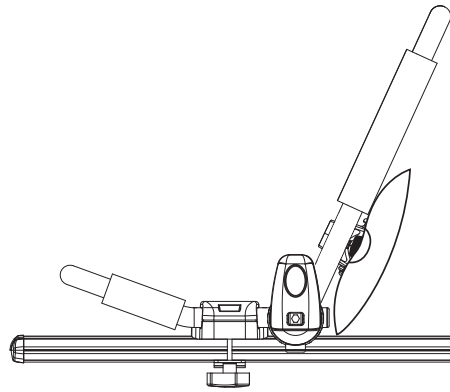
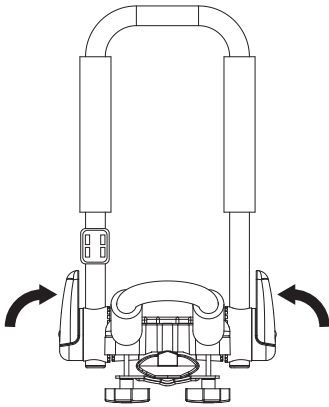

6

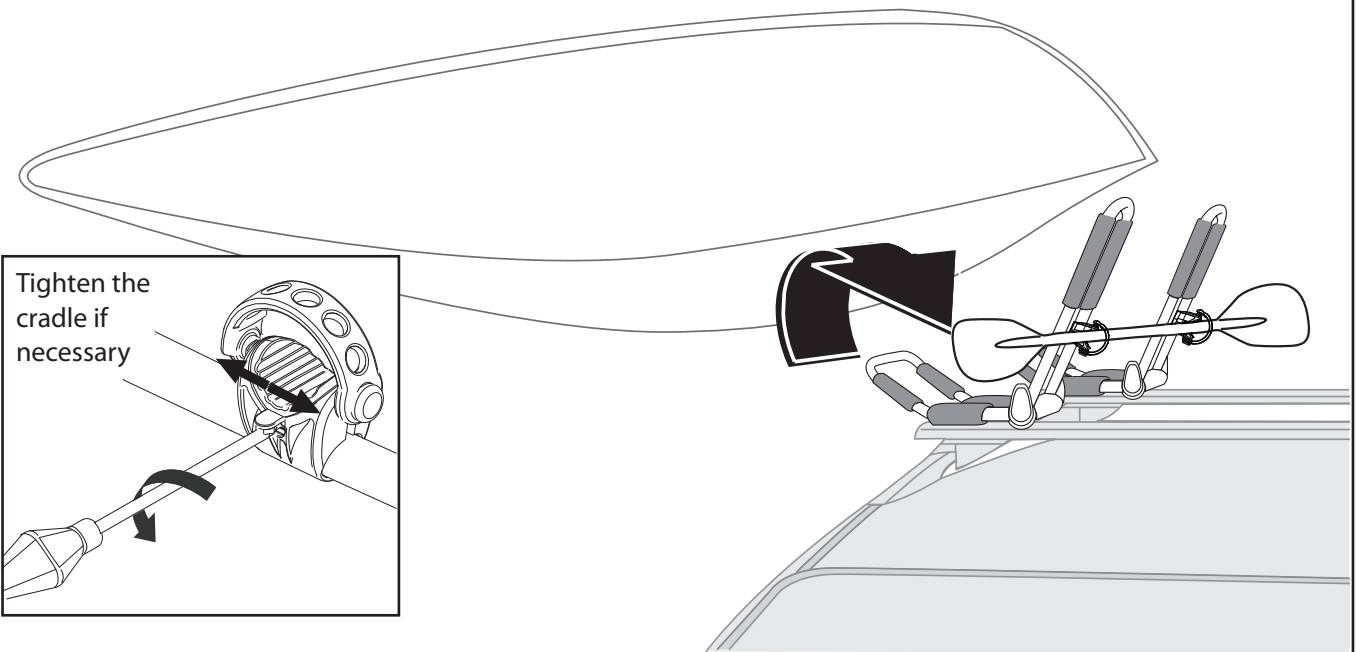

Tighten the cradle if necessary



Rhino-Rack Folding Kayak Carrier S512

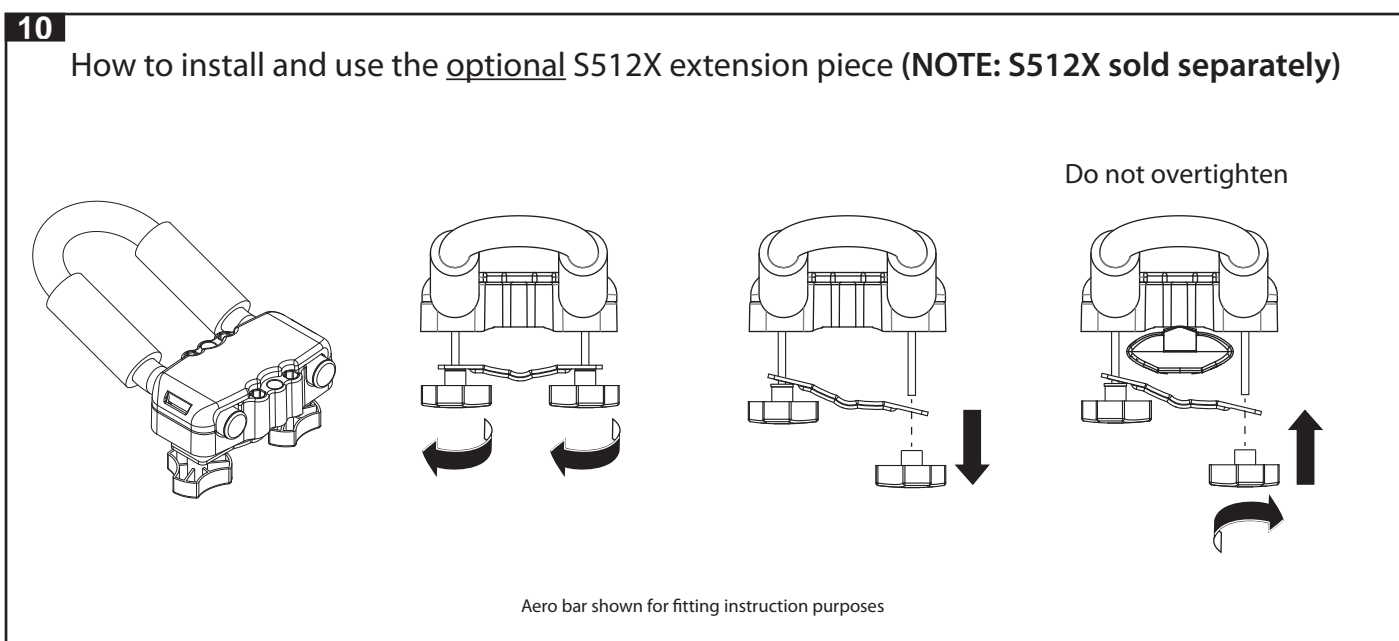
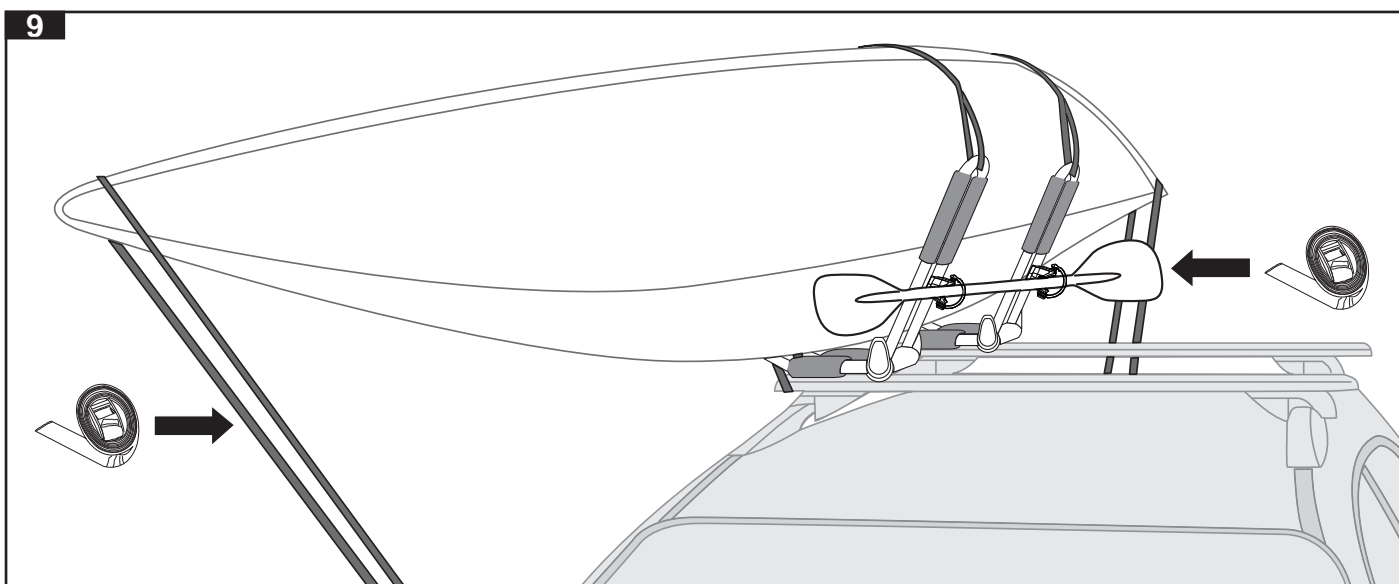
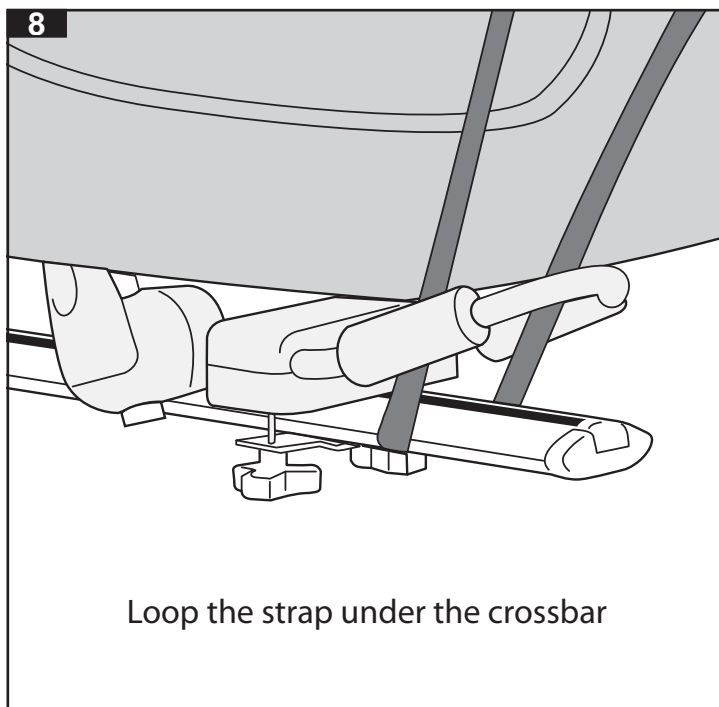
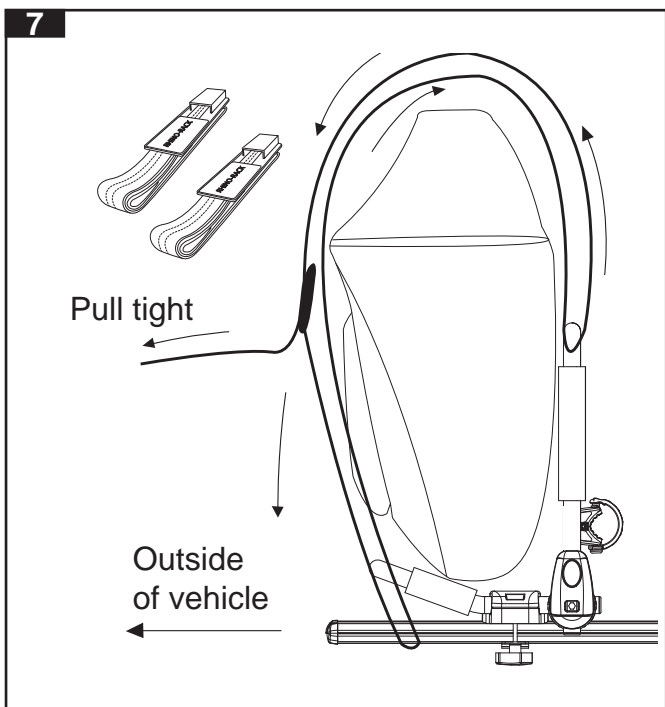



Rhino-Rack Folding Kayak Carrier S512

11 Fold in the cradle

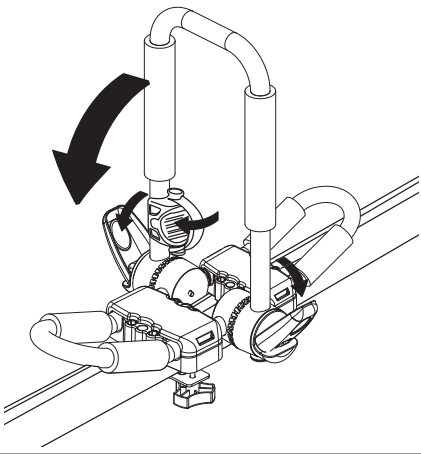

12

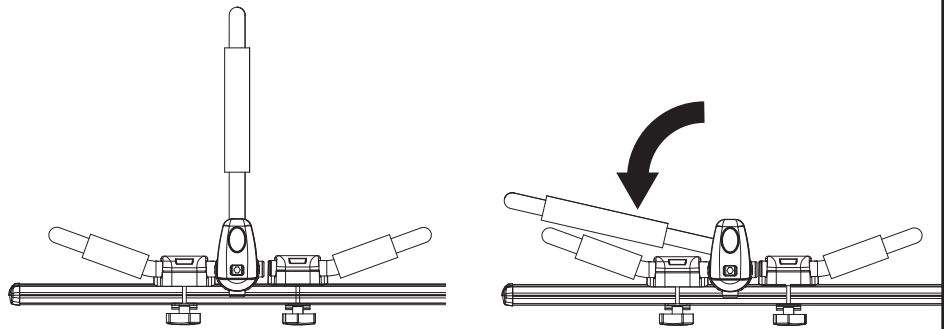

13

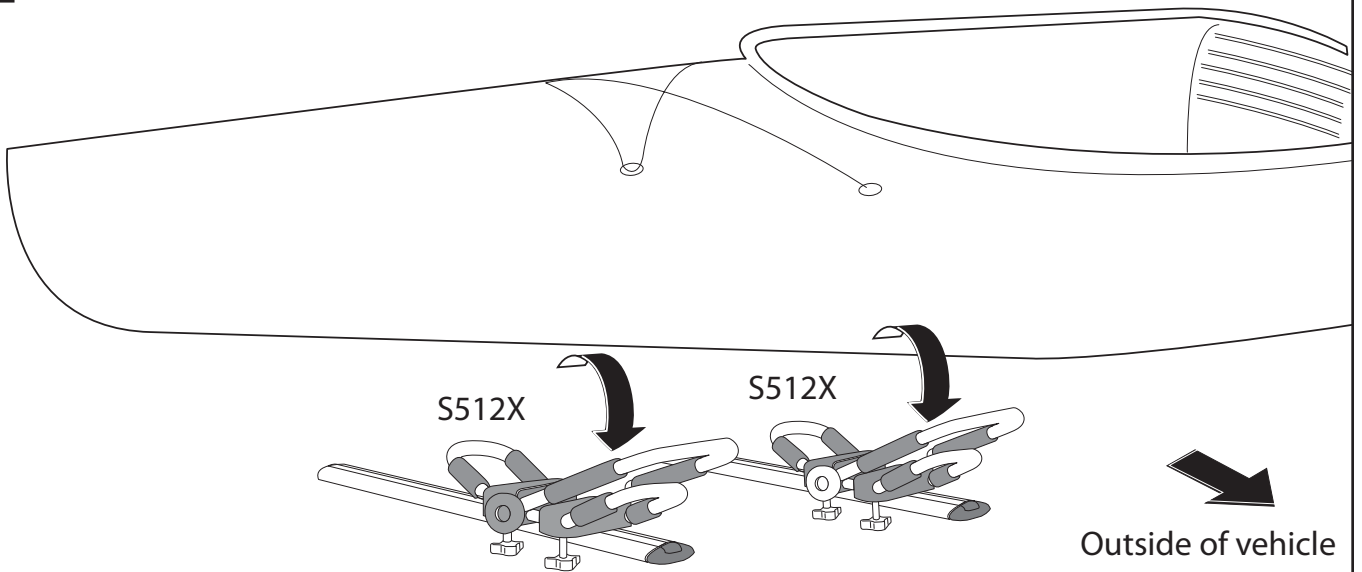

14

Keep the straps loose at this point

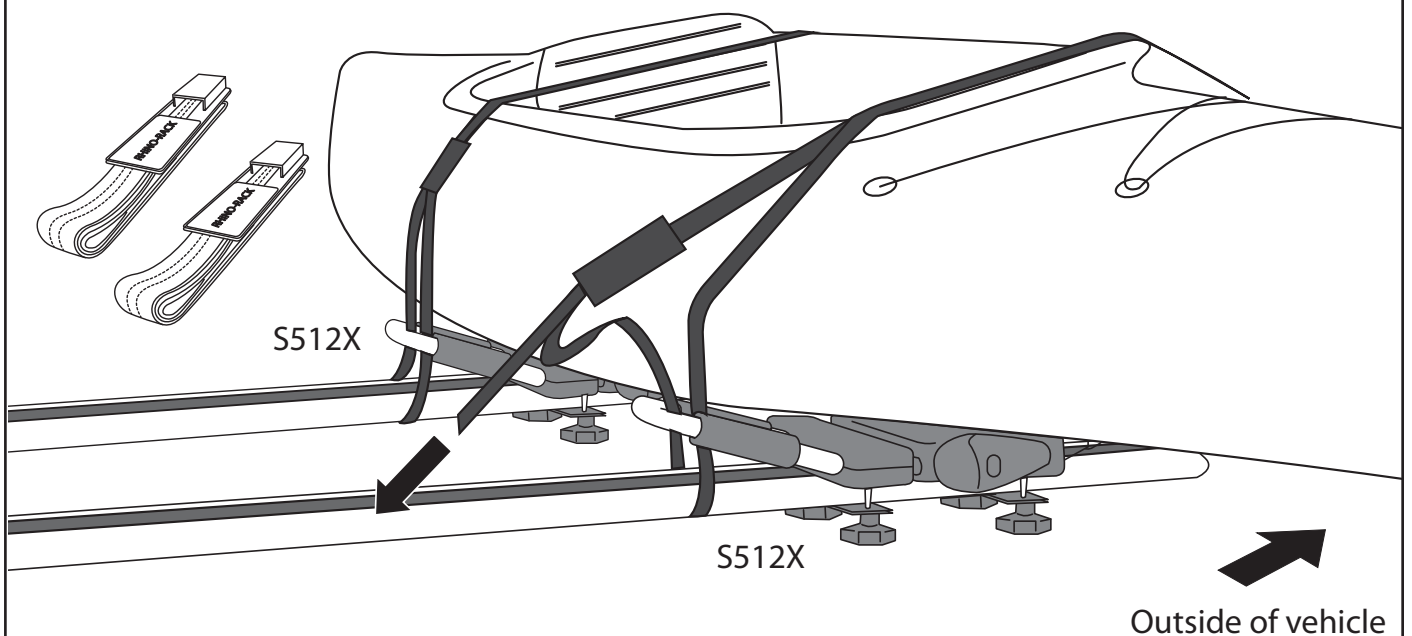



Rhino-Rack Folding Kayak Carrier S512

15

Rotate arm up and lock it in position as shown

Load 2nd canoe / kayak

Repeat steps 7 to 9

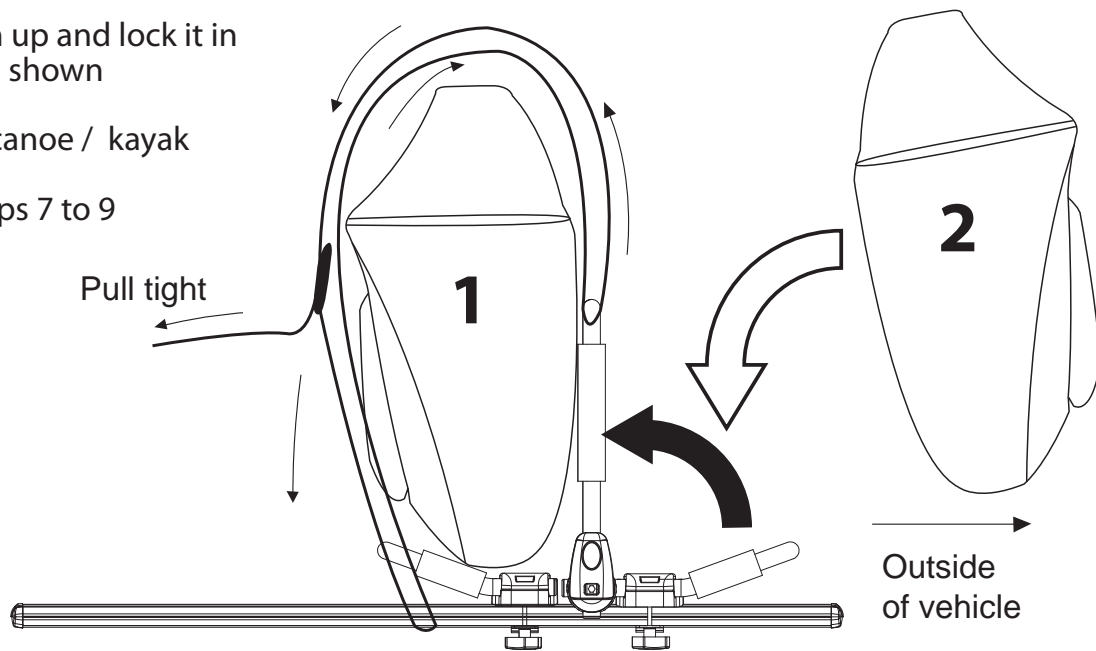

16

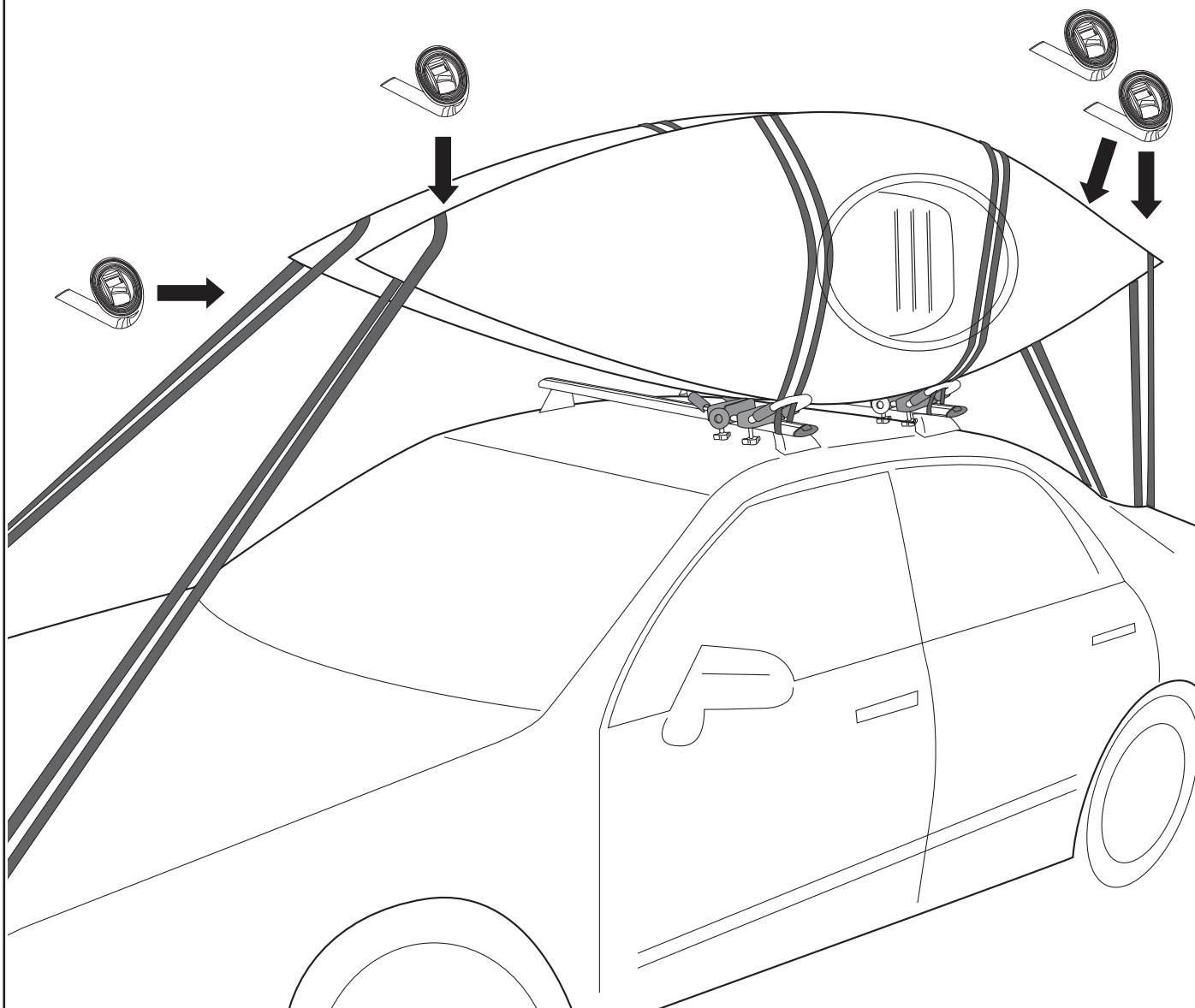



Rhino-Rack Folding Kayak Carrier S512

How to install and use the optional C- channel installation kit (NOTE: Sold Separately)

1

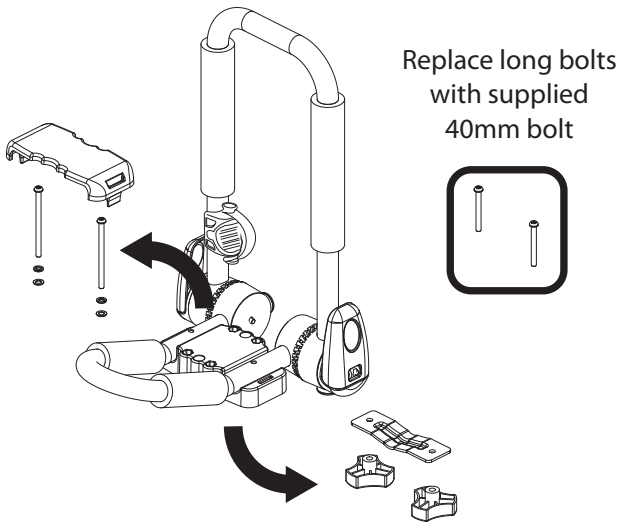

2

Pliers can be used to assist in inserting the rubber cover.

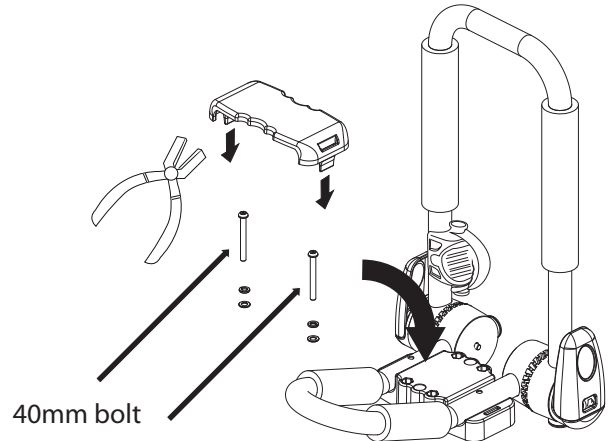

3

The 40mm bolts will not protrude out of the bottom. The carrier is now ready for the C-channel fitment

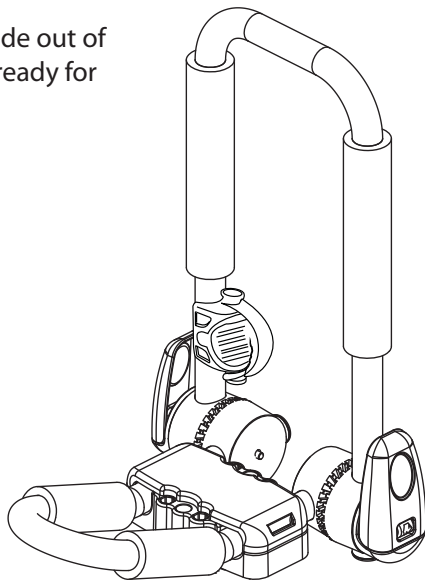

4

RHINO Sportz, RHINO Aero, THULE Rapid & New ROLA Rails bar (PART NO: KC-FK8)

Remove end caps and rubber buffer strip from roof cross bar.

Slide the Nut Plate into the top of the Roof Rack cross bar.

Put the two M6 x 32mm screw and washer assemblies through the middle hole in the base support and fasten to the Nut Plate.

Tighten to 3-4Nm.

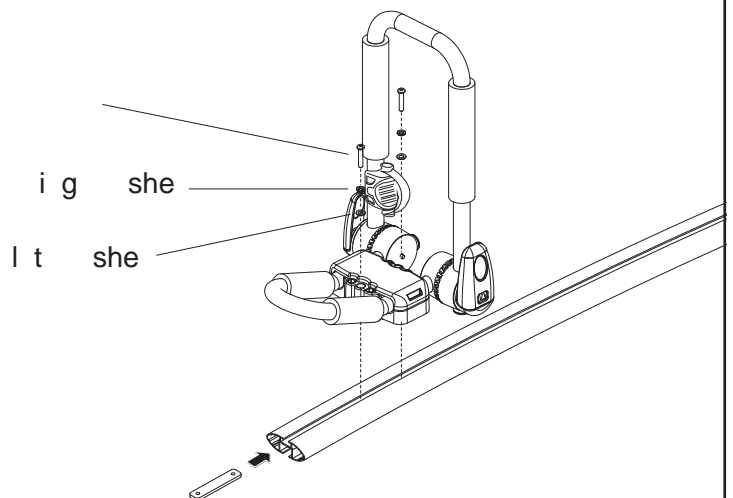



Rhino-Rack Folding Kayak Carrier S512

5

RHINO Heavy Duty (PART NO: KC-FK8)

Remove rubber buffer strip from Roof Rack cross bar.

Assemble hardware as shown.

Put the two M6 x 40mm screw and washer assemblies through the middle hole in the base support and fasten to the Channel Nuts.

Lock the Channel Nuts into the top of the roof cross bar. Check the Channel Nuts are located correctly.

Tighten to 3-4Nm.

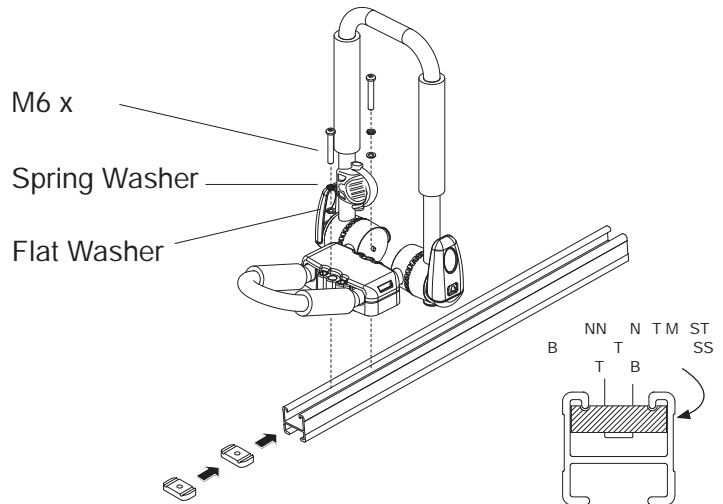

6

EUROPEAN Bars (PART NO: KC-FK10)

With the Kayak Carrier sitting on the Roof Rack bar, place the four M6 x 70mm Hex bolts through the four hexagonal holes in the base support.

Hook the two Lower U Adaptors under the cross bar. Place the M6 x 16 Washers on the Bolts and fasten using the four Plastic Knob Nuts.

Tighten to 3-4Nm.

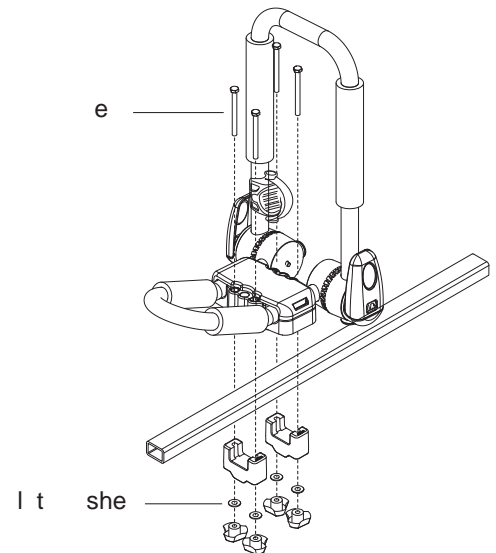

7

Rola Rack & old ROLA Commercial Bar (PART NO: KC-FK9)

Remove end caps and rubber buffer strip from Roof Rack cross bar.

Locate 'T' Bolt into cross bar channel, turn 'T' Bolt. Place Locking tab over 'T' Bolt.

Put the two M6 Tube Nut and washer assemblies through the middle hole in the base support and fasten to the M6 x 35mm T-Bolt.

Tighten to 3-4Nm.

