



RHINO-RACK

Aerodynamic & Heavy Duty Roof Rack Systems

Rhino-Rack Kayak T-Load Kit (RTLK)

Important: Please read these instructions carefully prior to installation. Please refer to your fitting instruction to ensure that the roof racks are installed in the correct locations. Check the contents of kit before commencing fitment and report any discrepancies. Place these instructions in the vehicle's glove box after installation is complete.

Layout

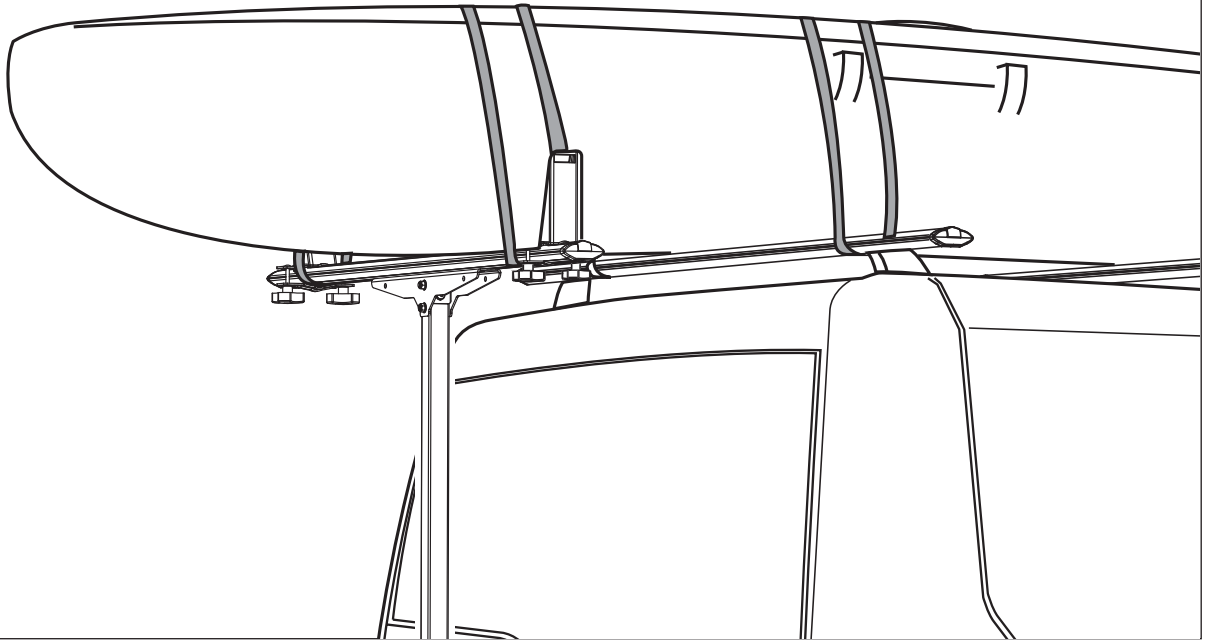

Important Information

Maximum carrying capacity:

Please refer to your vehicle manufacturers handbook for maximum carrying capacity of your roof racks. Always use the lower of the two figures. Load must be evenly distributed over the crossbars.

Warning: Do not attempt to fit the T-load kit to your vehicle unless you fully understand this fitting instructions. Please direct any questions regarding fitting to the dealer from where the T-load kit was purchased.

Use only non-stretch fastening ropes or straps.

Recommendations:

It is essential that all bolt connections be checked after driving a short distance when you first install your roof racks and T-load kit. Bolt connections should be checked again at regular intervals (once a week is enough, depending on road conditions, usage, loads and distances travelled). You should also check the roof racks and T-Load kit each time they are re-fitted. Always make sure to fasten your load securely. Please also ensure that all loads are evenly distributed and that the centre of gravity is kept as low as possible. Long loads (e.g. canoes and kayaks) must be secured front and rear with non-stretch fastening ropes or straps.

Roof racks must be removed when putting vehicle through an automatic car wash.

Caution: The handling characteristics of the vehicle changes when you transport a load on the roof. For safety reasons we recommend you exercise extreme care when transporting wind-resistant loads. Special consideration must be taken into account when cornering and braking.



Rhino-Rack Kayak T-Load Kit (RTLK)

Parts List

RTLK		
Item	Component Name	Qty
1	Cup Head Square Neck Long Bolt (HD)	4
2	Cup Head Square Neck Short Bolt (Aero)	4
3	Upper Clamp	2
4	Universal Clamp	2
5	M6 Flat Washer	4
6	Dial	4
7	Strap	1
8	Fitting Instruction	1

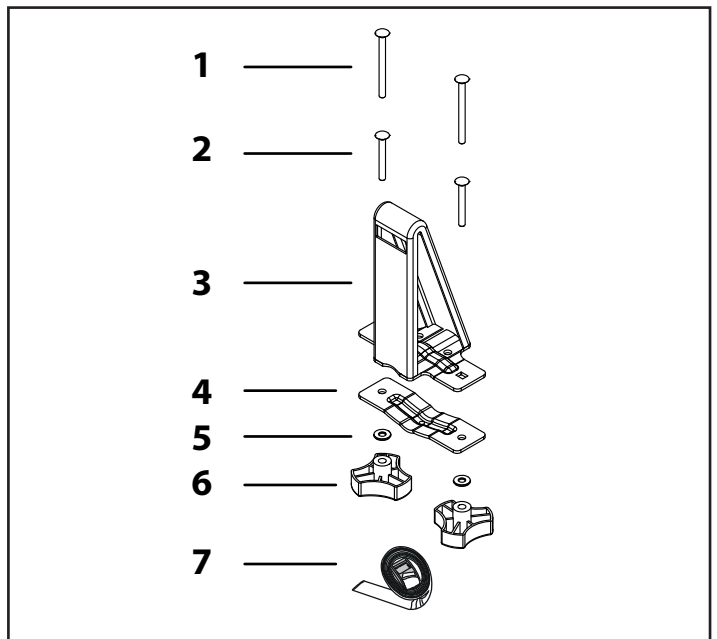

1a For Aero/Sportz

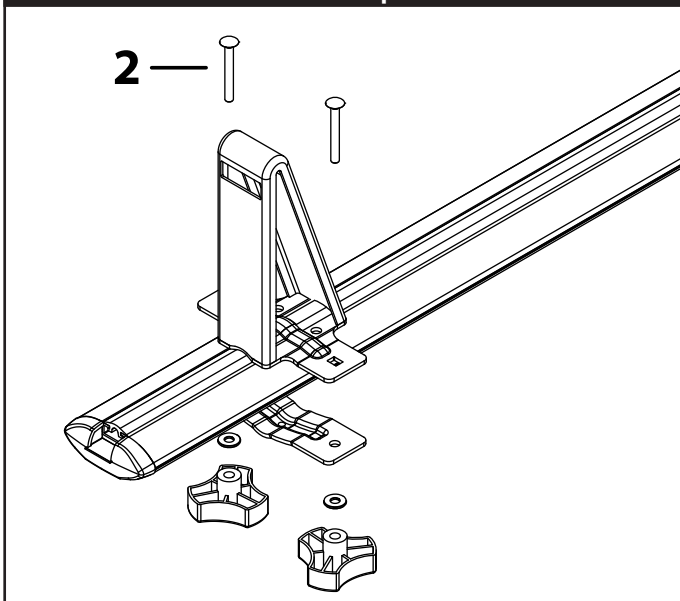

1b For Heavy Duty

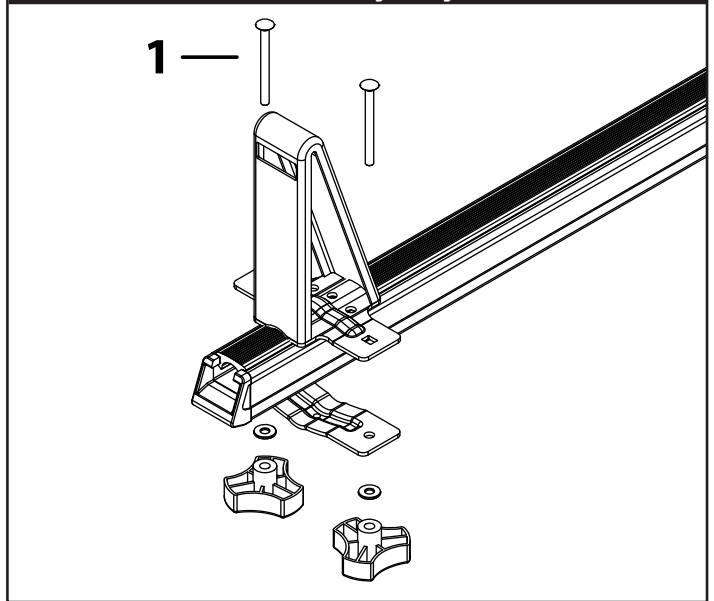

2a

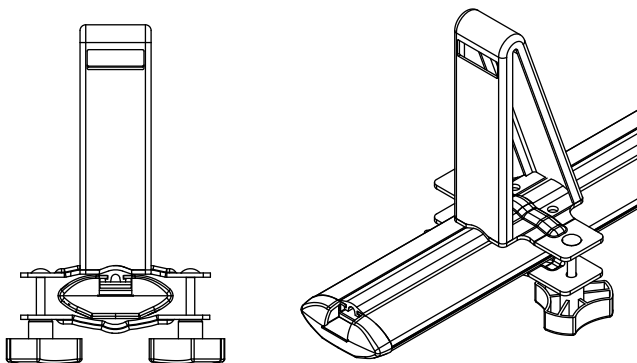

Do not overtighten
Overtightening may cause deformation
of the universal clamp

2b

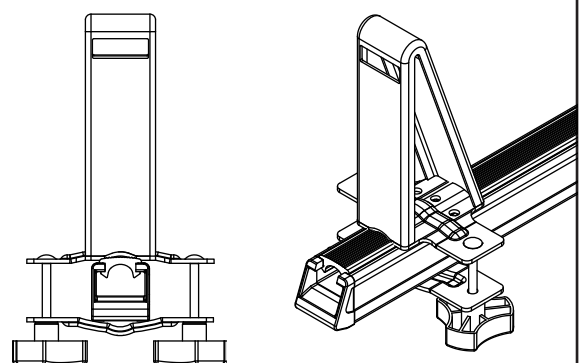

Do not overtighten
Overtightening may cause deformation
of the universal clamp



Rhino-Rack Kayak T-Load Kit (RTLK)

3 Insert both ends

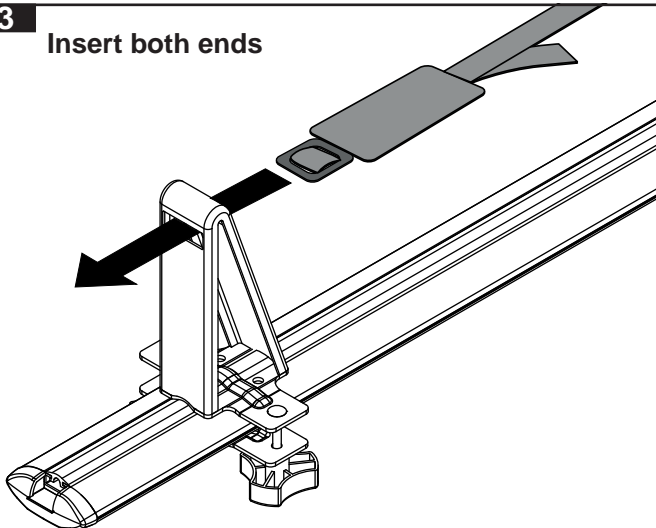

Aero bar shown for fitting instruction purposes

4 Flip the buckle on both ends

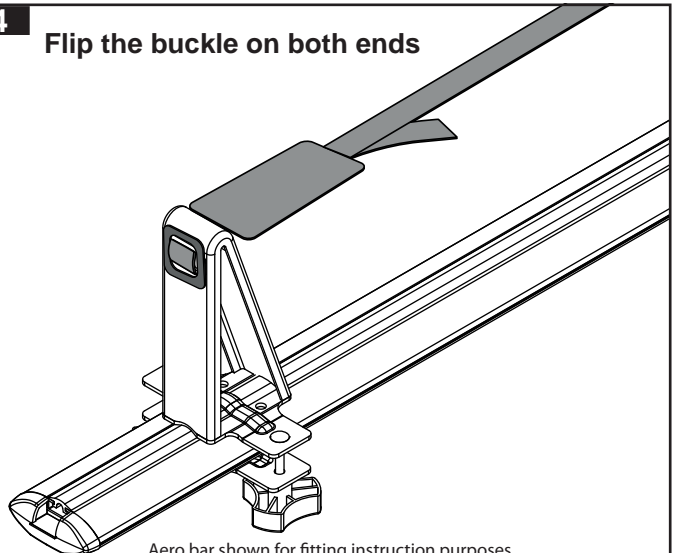

Aero bar shown for fitting instruction purposes

5 Pull strap to tighten
Lift buckle to loosen

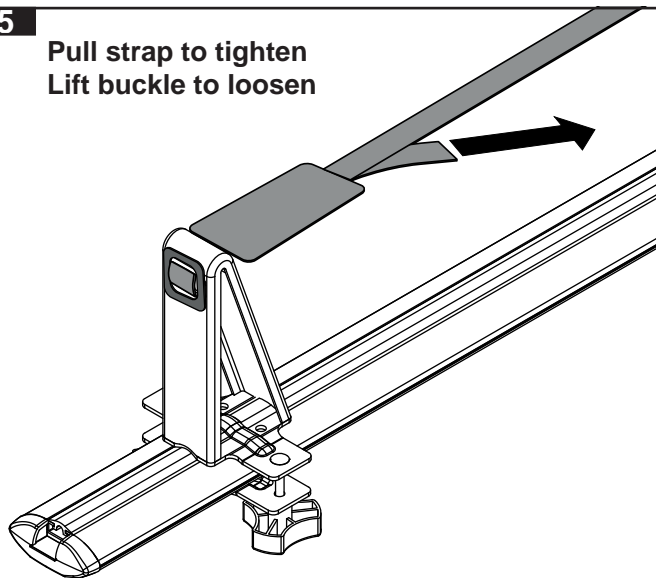

Aero bar shown for fitting instruction purposes

6 Keep strap in car when not in use

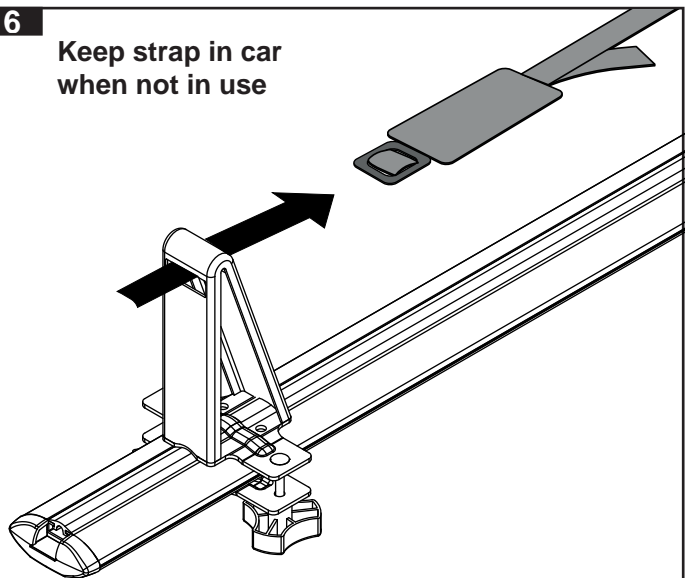

Aero bar shown for fitting instruction purposes

7

For KAYAKS / CANOES

Set spacing of supports to suit kayak or load.
Always have load evenly distributed over cross bars.

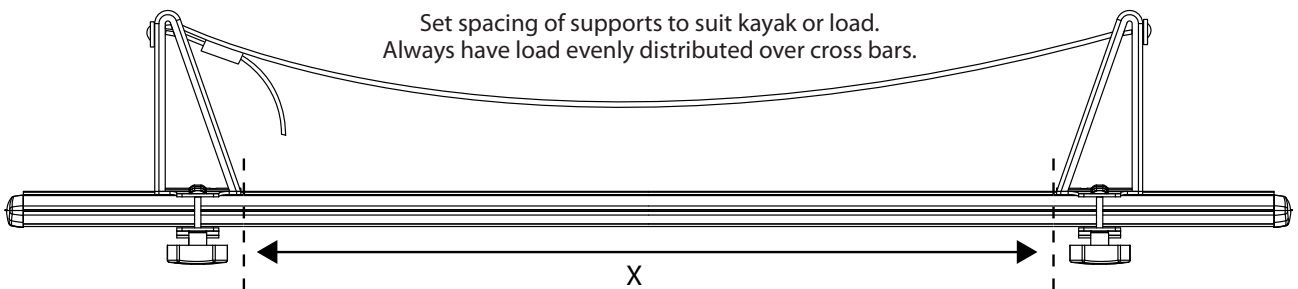

For LOAD STOP

Set spacing of supports to suit kayak or load.
Always have load evenly distributed over cross bars.

