



RHINO-RACK

RLH1,RLH2 Rhino Load Holder

Important: Please read these instructions carefully prior to installation. Please refer to your fitting instruction to ensure that the roof racks are installed in the correct locations. Check the contents of kit before commencing fitment and report any discrepancies. Place these instructions in the vehicle's glove box after installation is complete.

Layout:

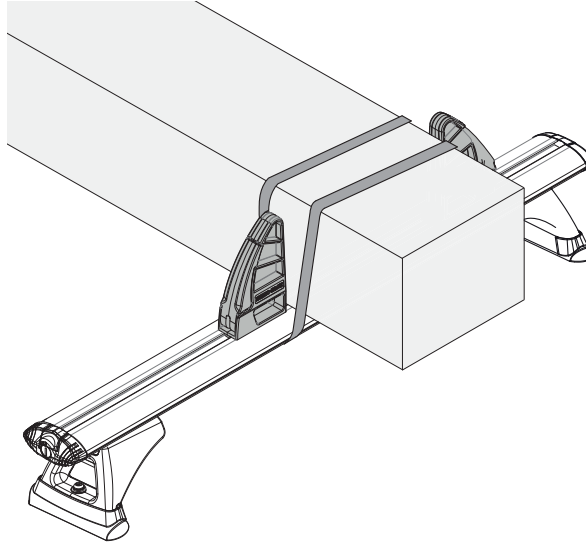

IMPORTANT Care Instruction:

Thoroughly clean roof bars prior to fitting Load Holder. PLEASE READ THROUGH INSTRUCTIONS BEFORE FIT-

Important Information

Please refer to your vehicle manufacturers handbook for maximum roof load capacity, always use the lower of the two figures.

Recommendations:

It is essential that all bolt connections be checked after driving a short distance when you first install your crossbars. Bolt connections should be checked and lubricated at regular intervals (probably once a week is enough, depending on road conditions, usage, loads and distances travelled). You should also check the crossbars each time they are refitted. Make sure to fasten your load securely. Please ensure that all loads are evenly distributed and that the centre of gravity is kept as low as possible.

Crossbars must be removed when putting vehicle through an automatic car wash.

Use only non-stretch fastening ropes or straps.

Caution: The handling characteristics of the vehicle changes when you transport a load on the roof. For safety reasons we recommend you exercise extreme care when transporting wind-resistant loads. Special consideration must be taken into account when cornering and braking.

The use of load holders is essential in preventing sideways movement of a load. Restricting this movement means straps cannot loosen and the load remains tight.



RLH1,RLH2 Rhino Load Holder

Parts List

Item	Component Name	Qty	Part No. For HD BAR	Part No. For VA BAR
1	Main Body	2	M660	M659
2	Cam Lever	2	M661	
3	M6 x Dowel Nut	2	A341	
4	T-Bolt	2	B215	B183 BLK
5	Instruction	1	R420	

Layout:

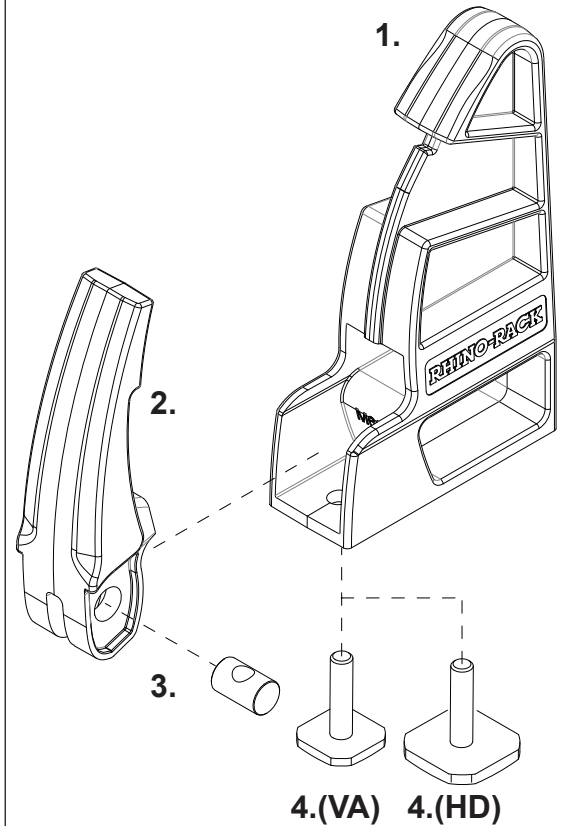

Instructions

- 1** Insert the barrel nut into the cam lever as shown.

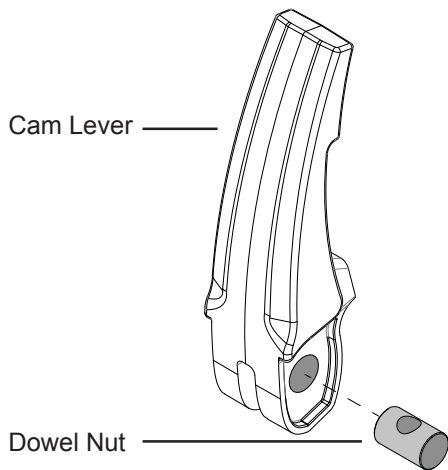

Note: Steps 1 to 3 are already complete when new but should you require to disassemble/assemble the unit follow these steps.

- 2** Insert the assembly created previously into the main body.

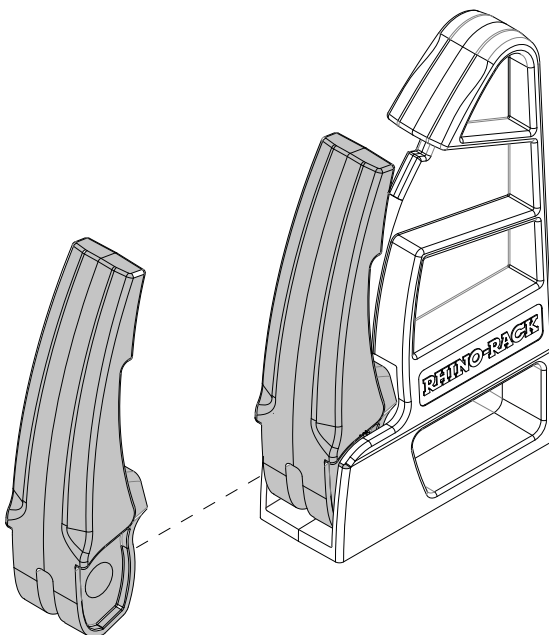

- 3** Insert the T-Bolt into the main assembly. Finger tighten half way.

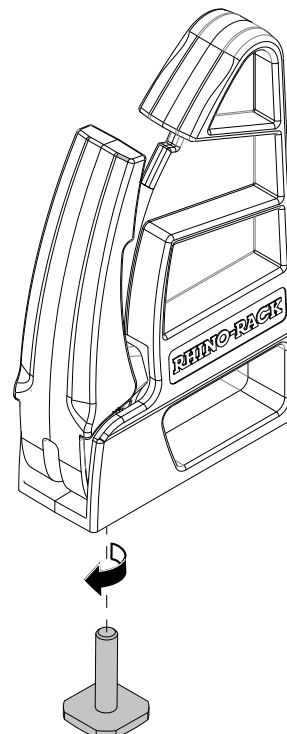



RLH1,RLH2 Rhino Load Holder

- 4** Open the Cam Lever as shown. This will allow the T-Bolt to slide easily into the Crossbar in the following step. Should it not fit easily, adjust the T-Bolt to suit. Note: Crossbar rubber must be removed.

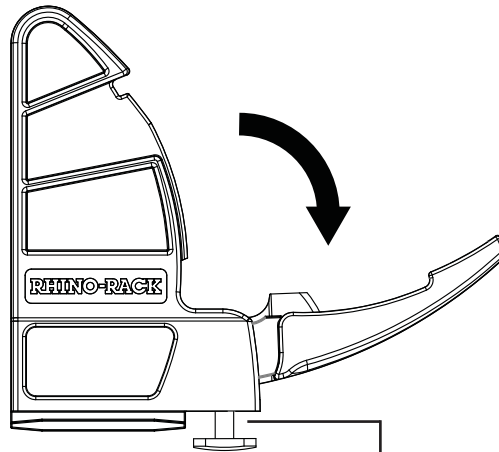

Note: Opening the lever leg lengthens the T-Bolt thread.

- 5** Slide the Load Stop assembly into the C-channel of the crossbar. Feed the Main Body guide and T-Bolt into the channel as shown.

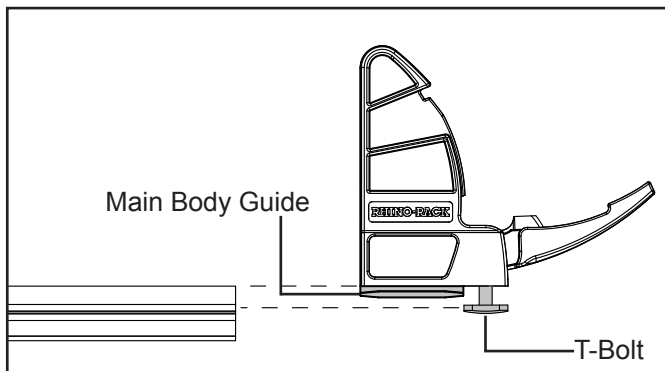

HD Assembly

VA Assembly

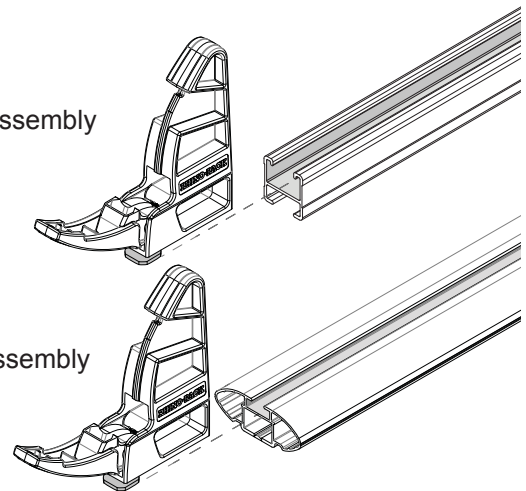

- 6** To lock the Stop in place, lift the Cam Lever up into a fixed position as shown. This will cause the T-Bolt to raise and grip the inside of the C Channel. Fine tune to the T-Bolt position by tightening or loosening the bolt to obtain the right locking pressure.

1. Lift the Cam Lever back into a fixed position. This may require some force.

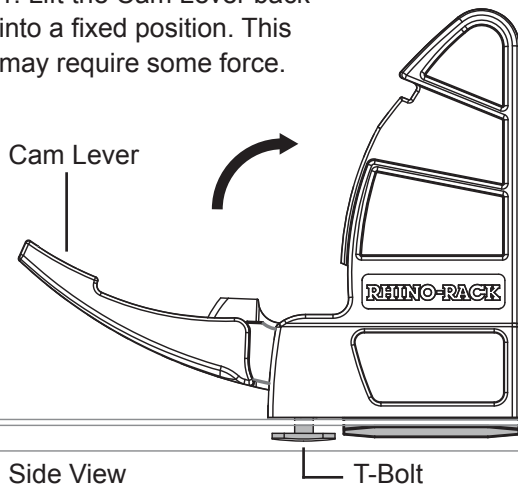

Side View

T-Bolt

2. With the Cam Lever raised, the T-Bolt will lock the Stop in place with a 'click' sound. Check that the unit cannot slide, adjust T-Bolt tighter if required.

CLICK!

The T-Bolt raises to lock the unit.

Side View

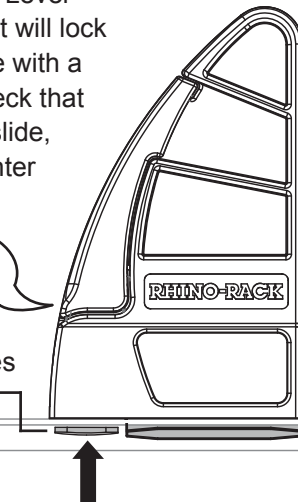



RLH1,RLH2 Rhino Load Holder

- 7** Adjust positioning of load stops to suit individual needs. Bring both units flush with load.

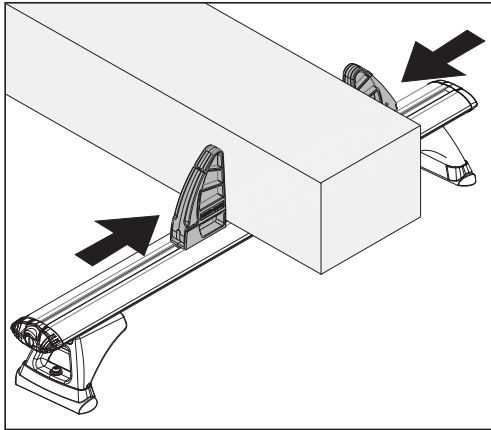

Repeat previous steps for remaining units.



X4

- 8** Check all fittings are secured.

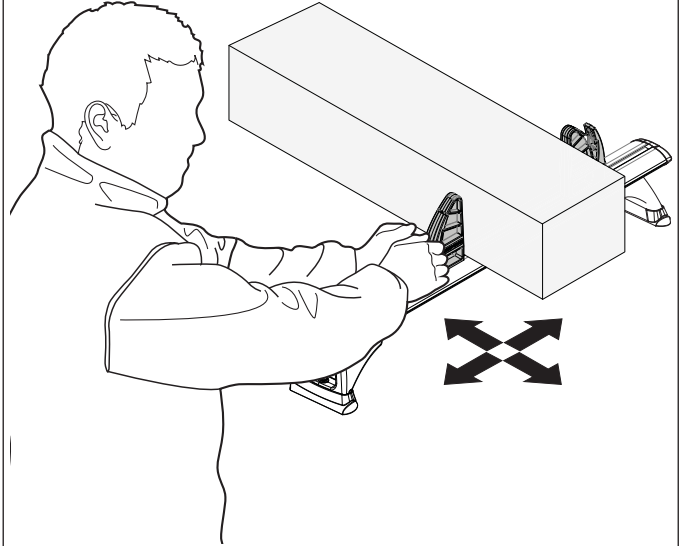

- 9** Secure load with Rhino Tie Down Straps. *Optional extra

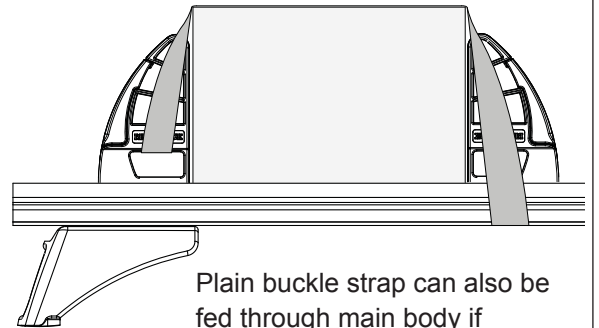
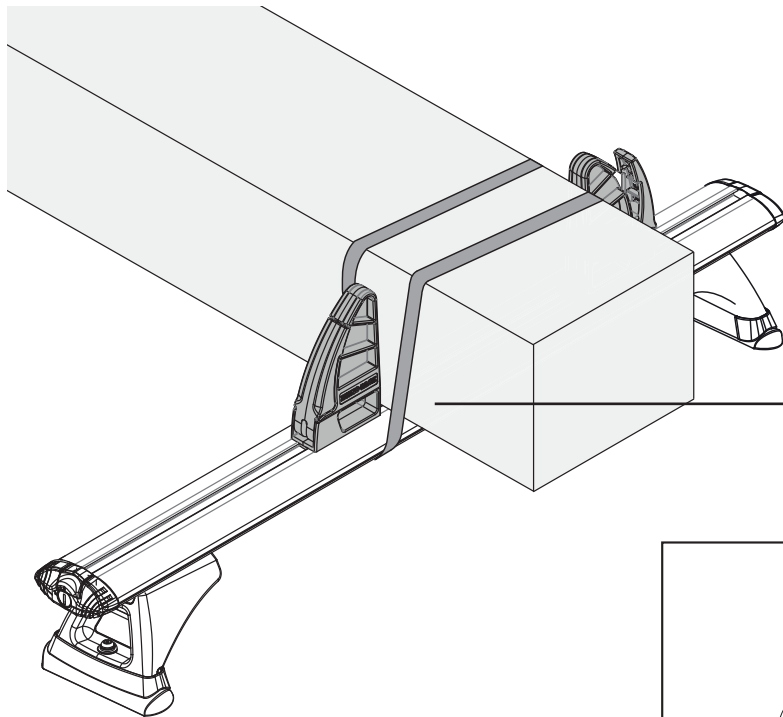

Plain buckle strap can also be fed through main body if assembly is positioned above a leg.

