

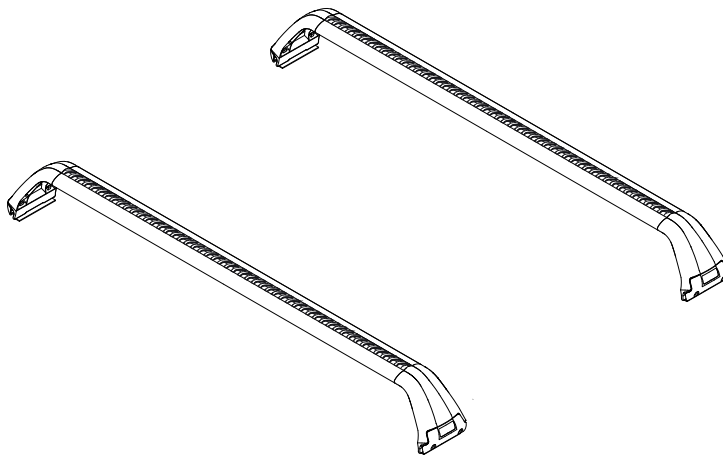

RHINO-RACK

Jeep Wrangler JK 2011- SG59 4dr & SG60 2dr- Rhino Sportz Gutter Mount

Important: Please read these instructions carefully prior to installation.
Check the contents of kit before commencing fitment and report any discrepancies.
Wash vehicle roof prior to fitting Rhino roof racks.



Important Information

Maximum carrying capacity: 40kg (88lbs) evenly distributed over the crossbars. Refer to your vehicle manufacturers handbook for maximum roof loading. Always use lower of the two figures.

Recommendations:

It is essential that all bolt connections be checked after driving a short distance when you first install your crossbars. Bolt connections should be checked again at regular intervals (probably once a week is enough, depending on road conditions, usage, loads and distances travelled). You should also check the crossbars each time they are refitted. Make sure to fasten your load securely. Please ensure that all loads are evenly distributed and that the centre of gravity is kept as low as possible.

Use only non-stretch fastening ropes or straps.

Caution: The handling characteristics of the vehicle changes when you transport a load on the roof. For safety reasons we recommend you exercise extreme care when transporting wind-resistant loads. Special consideration must be taken into account when cornering and braking.

Please remove crossbars when putting vehicle through an automatic car wash.

Load Ratings:

Maximum permissible load is 40kg (88lbs) for two crossbars including the weight of the crossbars, 5kg (11lbs). Roof racks are not to be used off sealed roads. Although the crossbars are tested and approved to AS1235-2000, Off road conditions can be much more rigorous. However, increasing the number of crossbars does not increase the vehicles maximum permissible roof loading.



Jeep Wrangler JK SG59 & SG60

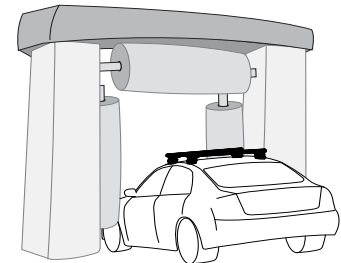
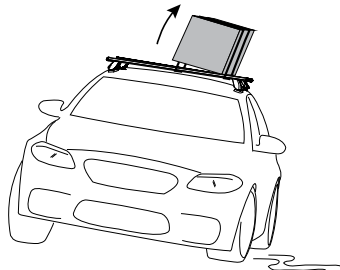
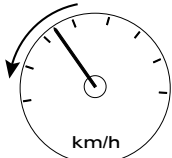
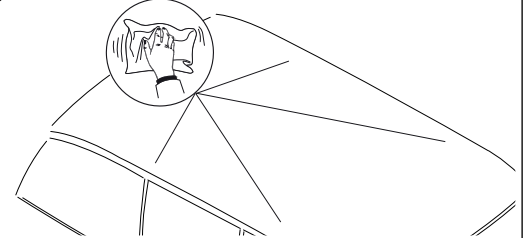
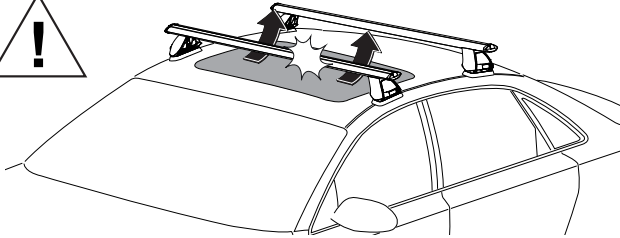
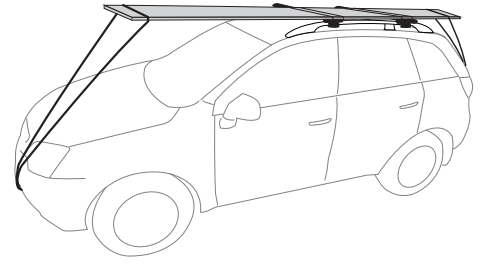
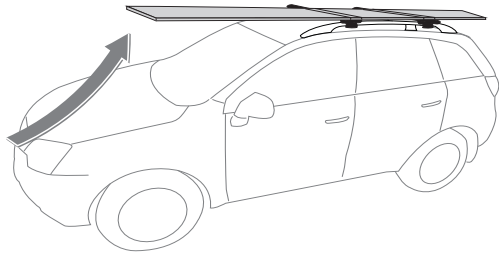

2 x Crossbars = 5kg/11lbs

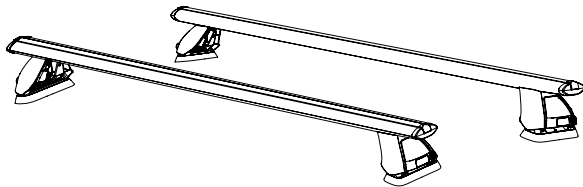

? kg/lbs

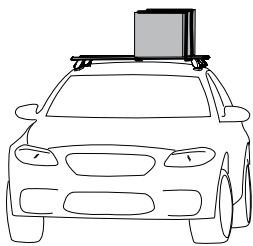
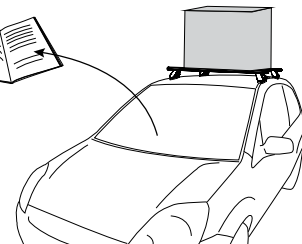

Max: 40kg/88lbs
(Urban road)



WARNING! Important Load Carrying Instructions

With utility vehicles, the cabin and the canopy move independently. Roof racks and vehicle can be damaged if the item transported is rigidly fixed at points on both the cabin and canopy. Instead, rigidly fix to either the cabin roof racks or the canopy roof racks.

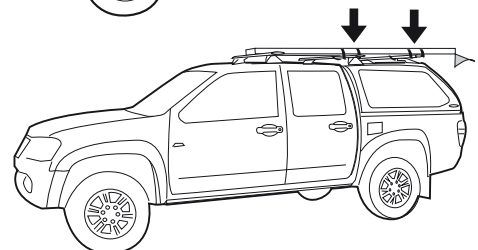
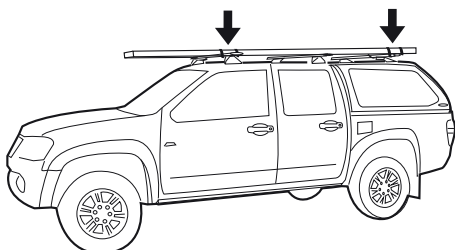
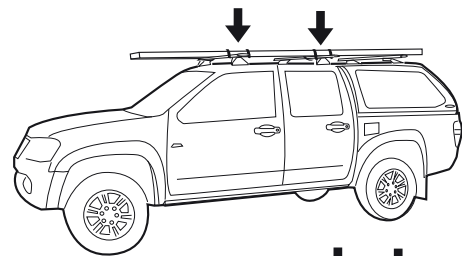



Jeep Wrangler JK SG59 & SG60

Parts List

Item	Component Name	Qty	Part No.
1	Vortex buffer strip	6.5	M626
2	Crossbar	2	A155
3	Sportz gutter mount leg	4	M055
4	U-section rubber	4	R017
5	Sportz gutter mount strap	4	CA1263
6	Sportz gutter mount clamp	4	M056
7	M6 x 40mm security screw	8	B085
8	M6 spring washer	8	W004
9	M6 x 12.5mm flat washer	8	W003
10	10g x 1/2" self tapping screw	4	B045
11	5mm security Allen key	1	SECKEY-S
12	Fitting instruction	1	R402

Tools Required:

5mm Allen key, provided in kit.
Tape measure.
Phillips head screwdriver.
Rubber Mallet.

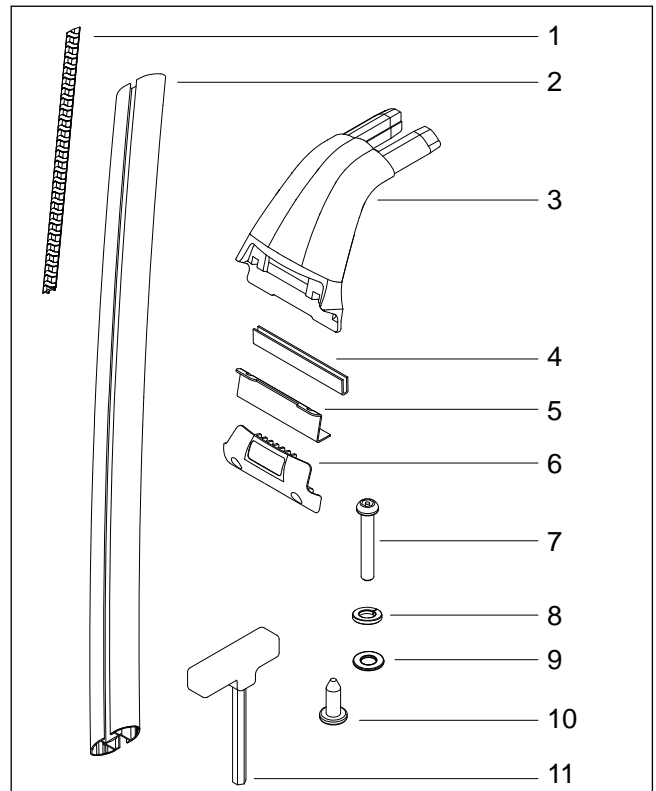

1

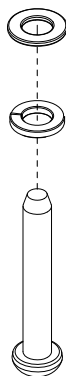

Assemble spring washer and flat washer onto M6 x 40mm security screws.

2

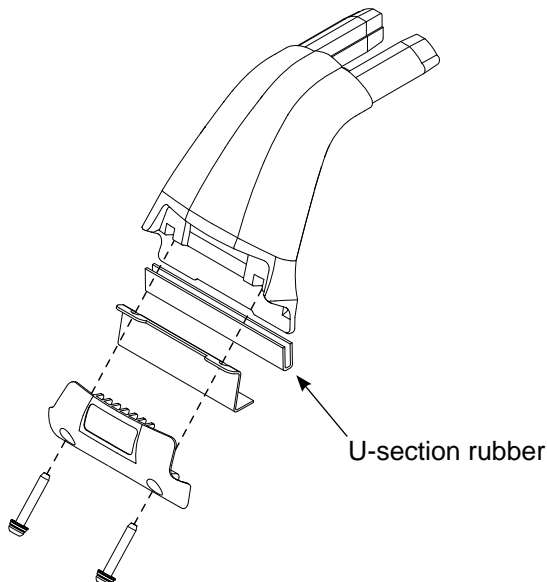

Insert security screw assembly through the cover strap, and fasten to the dowel nuts which are located in the support leg. Turn the screw so that it just engages into the dowel nut.

Attach the U-section rubber.



Jeep Wrangler JK SG59 & SG60

3

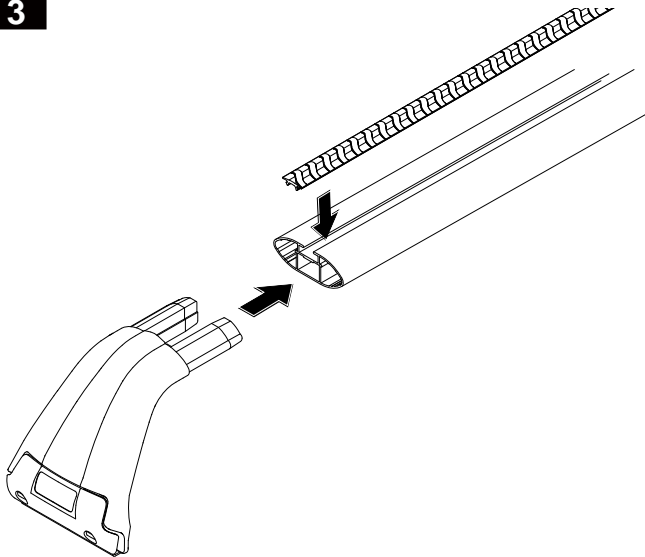

Locate support legs into the crossbar, a rubber mallet can be used to knock the legs in.

Insert the vortex buffer strips into the top of each crossbar. Trim off excess.

4

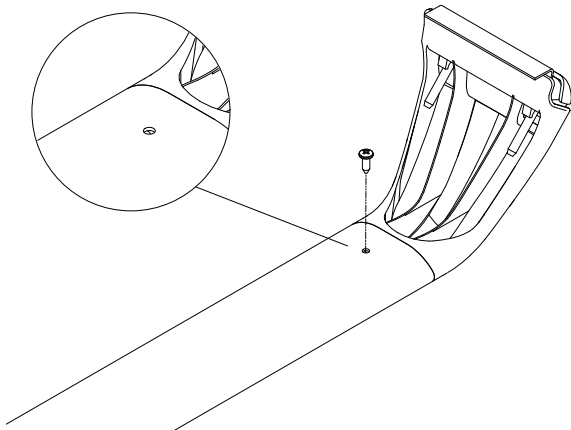

From underside of the crossbar fasten the 10G self tapping screw through the crossbar and into the leg. Repeat this process for all legs.

5

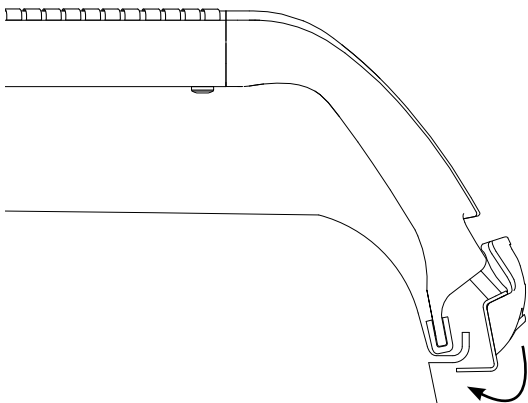

Swing the support leg strap under the gutter. Make sure that the strap is fully located under the gutter.



Jeep Wrangler JK SG59 & SG60

Jeep Wrangler 4dr hardtop

Front Crossbar = 1272mm

Rear Crossbar = 1291mm

A = 300mm

B = 500mm

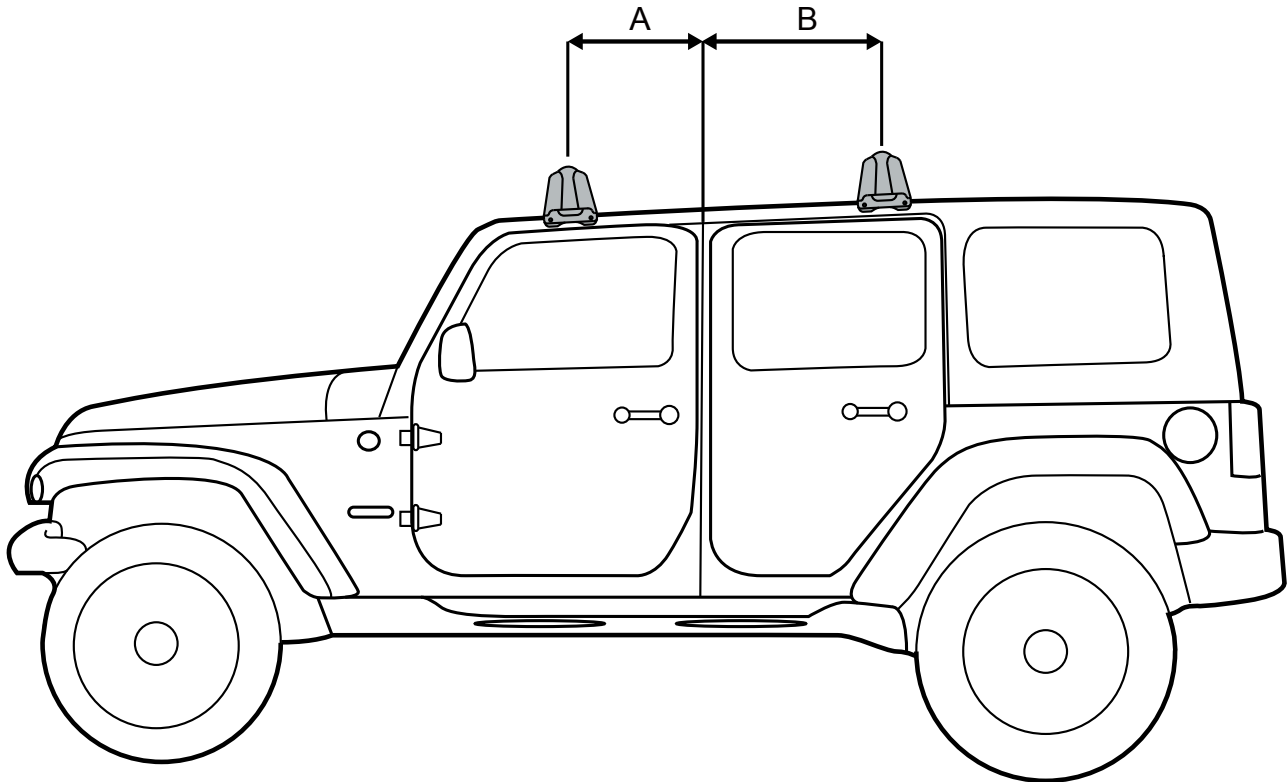

6

Measure forward 300mm (11,13/16") from centre of door jambs to centre of front leg. Measure rearward 500mm (19,11/16") from centre of door jambs to centre of rear leg, see diagram below. Progressively tighten each of the M6 screws. Tighten to 3-4 Nm (2-3 lbs/ft). Do not over tighten.

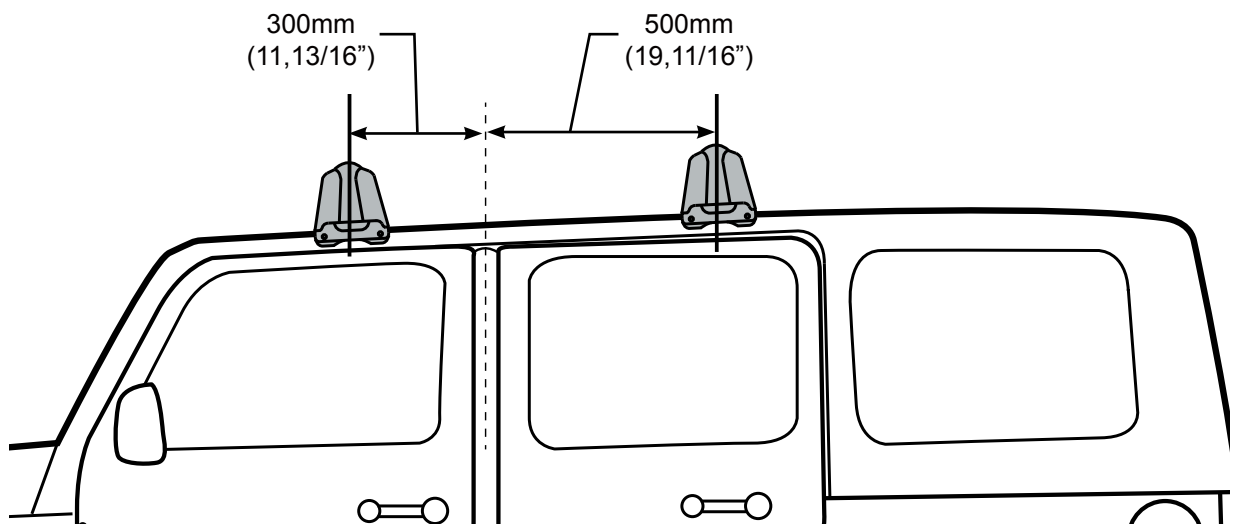



Jeep Wrangler JK SG59 & SG60

Jeep Wrangler 2dr hardtop

A. Front Crossbar = 1256mm

B. Rear Crossbar = 1283mm

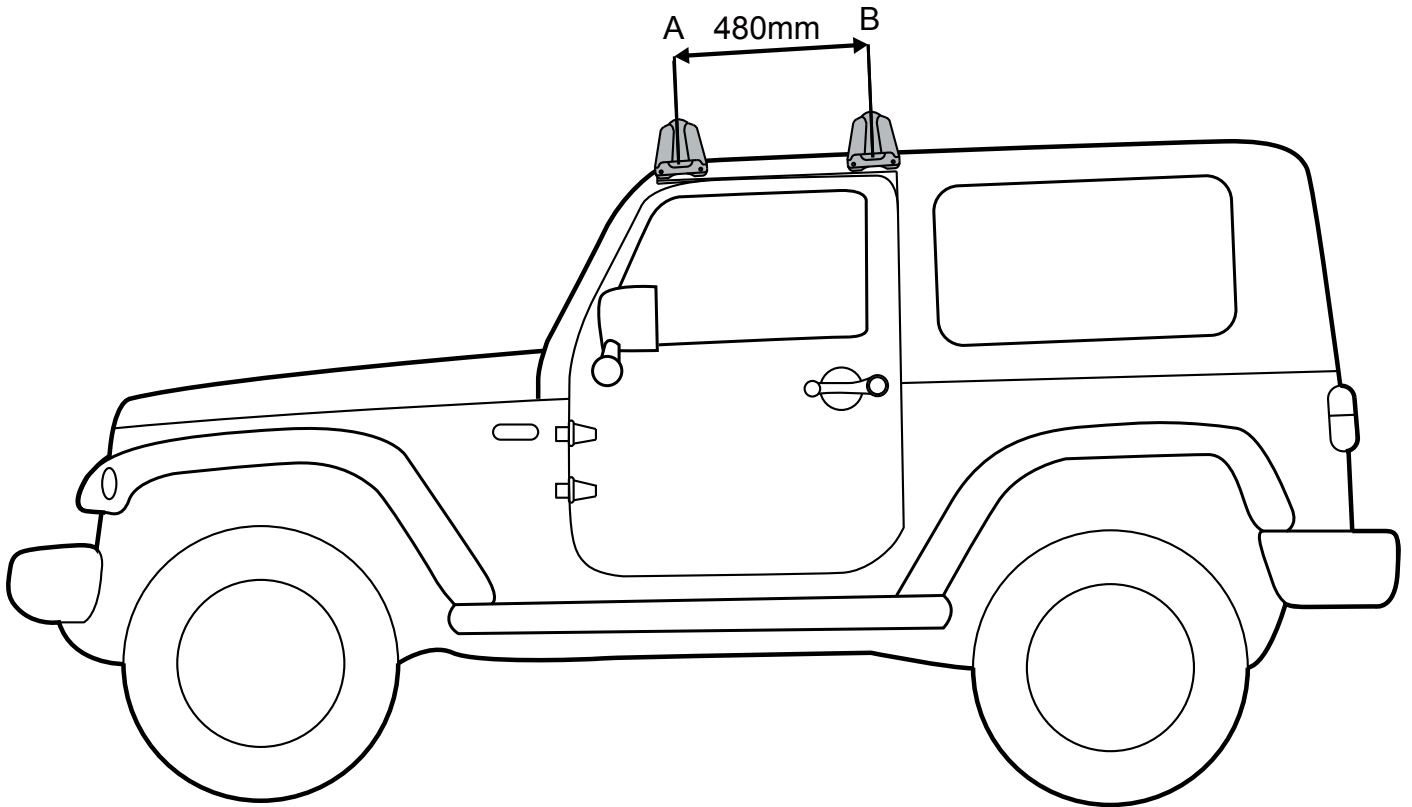

7

Measure forward 100mm (3,15/16") from the end of the rain gutter to the centre of the rear leg then a further 480mm (18,29/32") forward to the centre of the front leg, see diagram below. Progressively tighten each of the M6 screws. Tighten to 3-4 Nm (2-3 lbs/ft). Do not over tighten.

