



**INSTALLATION INSTRUCTIONS FOR 2010-12
DODGE 2500/3500 4WD
6" SUSPENSION SYSTEM
PART NUMBER 7306**

Requires the following parts for a complete installation:

- **Front Coil Spring Box depending on Gas or Diesel:**
 - ♦ Gas (Hemi) – P/N 7306-GS
 - ♦ Diesel – P/N 7306-DS
- **Box Kit – P/N 7306B**
- **Block Kit depending on Diesel/Gas:**
 - DIESEL – P/N 730BK
 - GAS – P/N 731BK

WARNING!!! READ AND UNDERSTAND ALL INSTRUCTIONS BEFORE PROCEEDING. MAKE SURE THAT YOU HAVE ALL TOOLS AND PARTS BEFORE BEGINNING THE INSTALLATION.

SPECIAL ITEMS REQUIRED:

- STEERING (PITMAN) ARM PULLER
- TIE ROD SEPARATING TOOL
- TORQUE WRENCH
- DODGE SERVICE MANUAL
- SPRING COMPRESSOR

REVTEK SUSPENSION RECOMMENDS THAT RED LOCTITE BE USED ON ALL FASTENERS UNLESS OTHERWISE NOTED. IT IS ALSO RECOMMENDED TO HAVE THE FRONT END ALIGNMENT CHECKED AFTER INSTALLATION.



GENERAL NOTES:

1. THIS SYSTEM SHOULD ONLY BE INSTALLED BY A PROFESSIONAL.
2. Compare all contents of the boxes to the parts list before starting to insure all components are included.
3. Prior to installing the suspension system, inspect the vehicle's suspension components, alignment, and frame for damage, corrosion, or cracks. Correct any worn or damaged parts before beginning install.
4. Always wear safety glasses during installation.
5. Unless otherwise noted, tighten all bolts to the torque specifications listed in the Torque Specification table included in these instructions. Use a torque wrench.
6. Estimated time to install this system is 6 hours.
7. Check off the step number at the beginning of each step when you finish it. Then when you stop during the installation, it will be easier to find where you need to continue from.

DRIVELINE MODIFICATION MAY BE NECESSARY!!!!

STANDARD BOLT TORQUE & IDENTIFICATION

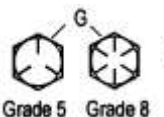
INCH SYSTEM			METRIC SYSTEM			
Bolt Size	Grade 5	Grade 8	Bolt Size	Class 9.8	Class 10.9	Class 12.9
5/16	15 ft. lbs.	20 ft. lbs.	M6	5 ft. lbs.	9 ft. lbs.	12 ft. lbs.
3/8	30 ft. lbs.	35 ft. lbs.	M8	18 ft. lbs.	23 ft. lbs.	27 ft. lbs.
7/16	45 ft. lbs.	60 ft. lbs.	M10	32 ft. lbs.	45 ft. lbs.	50 ft. lbs.
1/2	65 ft. lbs.	90 ft. lbs.	M12	55 ft. lbs.	75 ft. lbs.	90 ft. lbs.
9/16	95 ft. lbs.	130 ft. lbs.	M14	85 ft. lbs.	120 ft. lbs.	145 ft. lbs.
5/8	135 ft. lbs.	175 ft. lbs.	M16	130 ft. lbs.	165 ft. lbs.	210 ft. lbs.
3/4	185 ft. lbs.	280 ft. lbs.	M18	170 ft. lbs.	240 ft. lbs.	290 ft. lbs.

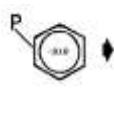
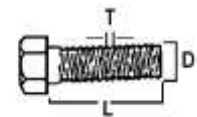
<p>1/2-13x1.75 HHCS</p> <div style="display: flex; justify-content: space-around; align-items: center;"> <div style="text-align: center;"> <p>D T L X</p> </div> <div style="text-align: center;">  <p>Grade 5 Grade 8</p> </div> <div style="text-align: center;">  </div> </div> <p>G= Grade Marking (bolt strength) L= Length (inches) D= Nominal Diameter (inches) X= Description (hex head cap screw) T= Thread Pitch (threads per inch)</p>	<p>M12-1.25x50 HHCS</p> <div style="display: flex; justify-content: space-around; align-items: center;"> <div style="text-align: center;"> <p>D T L X</p> </div> <div style="text-align: center;">  <p>P</p> </div> <div style="text-align: center;">  </div> </div> <p>P= Property Class (bolt strength) L= Length (millimeters) D= Nominal Diameter (millimeters) X= Description (hex head cap screw) T= Thread Pitch (thread width, mm)</p>
---	---

KIT CONTENTS INCLUDE:

- Instructions including parts list
- Product Safety Label (orange)
- Decal
- Warranty Information

PARTS LIST INCLUDED IN KIT

<u>COIL SPRING BOX- 7306-GS</u>	<u>QTY.</u>
6" GAS FRONT SPRING	2
<u>COIL SPRING BOX- 7306-DS</u>	
6" DIESEL FRONT SPRING	2
<u>DIESEL REAR BLOCK KIT- 730BK</u>	
2" REAR BLOCK	2
9/16 X 4.0 X 13-1/2 U-BOLT	4
9/16 FLAT WASHER	8
9/16 HIGH NUTS	8
<u>GAS REAR BLOCK KIT- 731BK</u>	
2" REAR BLOCK	2
9/16 X 3.5 X 13-1/2 U-BOLT	4
9/16 FLAT WASHER	8
9/16 HIGH NUTS	8
<u>SWAY BAR BRACKET HARDWARE</u>	
SWAY BAR BRACKET RIGHT	1
SWAY BAR BRACKET LEFT	1
<u>BOX KIT – 7306B</u>	
TRACK BAR BRACKET	1

SQUARE WASHER	1
TRACK BAR SLEEVE (LONG)	1
9/16 X 3-1/4 GRADE 8 HEX BOLT	1
1/2 -13 X 1-1/2 GRADE 8 HEX BOLT	2
1/2-13 X 3-1/4 GRADE 8 HEX BOLT	1
SAE 9/16 FLAT WASHER	4
9/16-12 GRADE C LOCKNUT	2
SAE 1/2 FLAT WASHER	6
1/2-13 GRADE C ALL METAL LOCKNUT	3
9/16 X 6 GRADE 8 BOLT	1
DODGE AXLE FORWARD LOWER ARM	2
DODGE AXLE FORWARD UPPER ARM LEFT	1
DODGE AXLE FORWARD UPPER ARM RIGHT	1
REAR SHOCKS	2
FRONT SHOCKS	2
FRONT SHOCK STEM SPACER	2
SHOCK SLEEVE TUBE	4
1/4-90 ZERK FITTING	8
UPPER CONTROL ARM BUSHING	8
LOWER CONTROL ARM BUSHING	8
UPPER CONTROL ARM SLEEVE	4
LOWER CONTROL ARM SLEEVE	2
LOWER CONTROL ARM SLEEVE-LOWER FRONT	2
DODGE SWAY BAR DROP-RIGHT	1
DODGE SWAY BAR DROP-LEFT	1
DRIVELINE SPACER	1
7/16 - 14 X2 GRADE 8 BOLTS (ZINC)	4
CARRIER BEARING DROP BRACKET	2
PITMAN ARM	1
9/16 FLAT WASHER-BLACK	3
10MM X 1.5 X 50MM BOLT	2
SAE 7/16 FLAT WASHER	2
3/8-16 X 1.5" GRADE 5 HEX BOLT	4
3/8 FLAT WASHER (ZINK)	8
3/8-16 NYLON INSERT LOCKNUT	4
16MM X 80MM HEX BOLT	1
16MM ALL METAL LOCK NUT	1
16 MM FLAT WASHER ZINC	2
6.25 X 2 CLEAR DECAL	4
INSTRUCTION SHEET & SAFETY LABEL	1
DODGE BOX	1

FRONT DISSASSEMBLE

- 1) Place vehicle on level concrete surface and chock rear wheels.
- 2) Remove upper sway bar end link nuts. (Save For Re-Installation)
- 3) Remove cotter pin and castle nut (13/16" wrench) from the drag link where it attaches to the pitman arm. Using appropriate tools, separate tie rod end from pitman arm. You will be re-using this hardware.
- 4) Remove the pitman arm nut and washer. Mark the orientation of the stock pitman arm in relation to the sector shaft so that the new arm will be installed in the same orientation.
- 5) Remove the pitman arm from the sector shaft using the appropriate puller.
- 6) Remove the track bar bolt and let the track bar rest on the axle. You will not be re-using the track bar bolt, a new 16MM bolt is provided in the kit.
- 7) On each side, remove the brackets securing the brake hose assemblies to the front axle (13mm socket) save hardware for re-use.
- 8) Remove lower shock bolts (21mm socket)
- 9) Remove upper shock bracket nuts (3) each side (15mm wrench), lift shocks out of vehicle. On Hemi models you may have to remove the air box to access the right shock.
- 10) Raise the front of the vehicle with a jack and support the vehicle with jack stands on the frame rails behind the lower control arms.
- 11) Remove the front wheels (15/16" socket)
- 12) Remove the front coil springs.
- 13) Mark the cam alignment adjusters on the lower control arms so that you will have an alignment baseline when you re-install the new arms.
- 14) Remove the control arms and save all of the hardware for re-use.

Note: On diesel trucks the upper right rear bolt will either need to be cut out (new bolt supplied-9/16" X 6") or the exhaust system will need to be removed. New bolt must be installed from outside of frame using up to three 9/16" black thick washers on inside of frame.

FRONT ASSEMBLY

15) Assemble control arms with zerk fittings facing inward toward the opposite end of the arm. Assemble bushing halves and sleeves using a silicone based grease.

16) Install the lower control arms with the zerk fittings facing up. It is recommended to torque the control arm bolts to 160 ft. lbs at this point.

17) Install the upper control arms; on the axle side, the zerk fitting will face down and the angled control arm eyelet will face out toward the tire. It is recommended to torque the control arm bolts to 120 ft. lbs at this point.

18) Position the track bar bracket on the factory upper track bar mount as shown in figure (A).

19) Install the 1/2-13 x 3-1/4" grade 8 bolt and 1/2" flat washer loosely, (do not tighten) through the slotted hole in the Revtek bracket and slotted existing hole in the frame cross member as shown in figure (B).

20) The 1/2" bolt and 1/2" washer should be installed from the bottom with the large square washer, 1/2" washer and grade C all metal lock nut on top of the cross member.

21) Install the 9/16" x 3.5" bolt and one 9/16 SAE flat washer through the upper track bar bracket hole as shown in figure (A) (bolt, washer, revtek ear, front frame ear, sleeve, back of revtek ear bracket, rear of factory frame ear, 9/16" SAE washer, and all metal lock nut).

22) Tighten the 1/2" x 3-1/4" vertical bolt to 55 ft. lbs and then tighten the 9/16" x 3.5" upper track bar bolt to 75 ft. lbs.

23) Drill a 1/2" hole through the front frame ear by drilling through the existing 1/2" hole in the Revtek track bar bracket. See fig. A. (Repeat) this process on the rear of the track bar bracket, making sure to have full contact between the revtek bracket and frame ear. **Failure to drill these holes may cause popping noise or breakage from truck.**

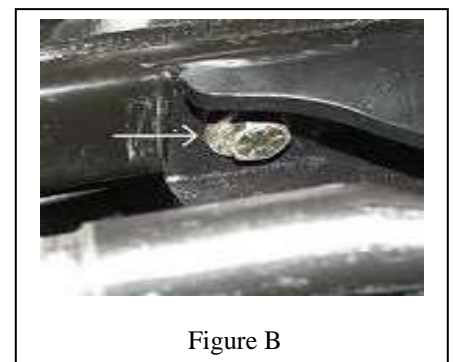

- 24) Install the supplied 1/2" x 1 1/2" bolts and all metal locknuts through the holes you just drilled.
- 25) Tighten all hardware on track bar bracket at this time.
- 26) Install the new pitman arm with the existing nut and washer using loc tight and torque to 225lbs.
- 27) Install the coil springs.
It may be easier in some cases to compress the spring slightly to install them.
- 28) Install the front shocks and tighten the lower bolts (21mm socket) torque to 90 ft. lbs. do not install the top of the shock at this point.
- 29) Install the front wheels, (15/16" socket) and tires at this point so that you can let the truck down fully on the ground. Torque factory lug nuts to 145 ft. lbs. on factory wheels.
- 30) With the truck now fully on the ground it is time to install the top shock towers and the shocks to the towers. Please install the new aluminum shock extensions (P/N- SS-75) over the shock stud. This spacer will have a counter bore in it that will fit over the welded washer at the bottom of the shock stud. Install all remaining shock hardware above this spacer. Shock tower nuts use (15mm wrench), shock top nuts use (3/4" socket).
- 31) Install the steering link to the small end of the pitman arm using the OEM hardware. (13/16" wrench) torque to 65 ft. lbs.
- 32) Install the track bar bolt at this time by turning the steering wheel slightly from side to side in order to line up the hole. Install the remaining 16MM bolt, washers and all metal lock nut. Torque to 90 ft. lbs
- 33) Secure the brake line brackets back to the front axle using OEM bolts (13mm socket). Torque to 18 ft. lbs.
- 34) Install the sway bar drop brackets to the frame using the OEM bolts. Make sure you have the left and right positioned properly. Install the sway bar to the drop brackets using the supplied 3/8" hardware. See fig F

FIG F



FIG G



35) Install the driveline spacer at the transfer case end of the front drive shaft with the 7/16 X 2" bolts supplied. (USE RED LOCK TITE ON THESE BOLTS) See fig G.

INSTALLATION OF REAR KIT

- 1) Place vehicle on level concrete and chock the front wheels.
- 2) Position a floor jack under the rear axle to raise the vehicle.
- 3) Place jack stands under frame rails in front of the forward spring hangers.
- 4) Ease the jack down until the frame is resting on jack stands while keeping slight pressure on the jack.
- 5) Remove tires and shocks.
- 6) Doing one side at a time! Remove the u-bolts and lower the axle down just far enough to install the block. You will install the blocks with the small end forward and the pin down.
- 7) Install the supplied u-bolts, nuts and washers and torque to 90 ft. lbs.
- 8) Repeat this procedure on the other side.
- 9) Install the new rear shocks using special upper and lower steel sleeves 1.5x.560 ID (supplied in main hardware bag) and torque to 35 ft. lbs.
- 10) Install the rear wheels and tires. OEM lug nuts and OEM wheels torque to 145 ft. lbs.
- 11) Use the (2) supplied carrier bearing drop down brackets (stacked) and the supplied hardware if the vehicle has a two piece rear drive shaft.

Important Installation Notes:

- Manufacturing tolerances do create certain variations that we cannot fully account for. At times you may need to use a punch, or pry bar to get holes to line up. Also you may need to slightly enlarge a hole to create a proper alignment. These are all normal situations.
- Altering your suspension may change the way your vehicle handles. Care must be taken to operate your vehicle safely.
- Adding large wheels and tires, will change how your suspension operates. It may put extra strain on certain components causing them to wear sooner than normal.
- While every effort is made to design our kits to work within factory geometry, there are situations where additional alignment tools like adjustable or replacement components may be needed. This is normal.
- It is possible when changing the driveline angles that a vibration may occur, and require an adjustment to repair this situation.
- Other modifications may be needed due to optional equipment on the vehicle or other prior modifications that have been made.
- All fasteners should be checked and retightened after 500 miles. After the initial recheck, they should be checked and tightened as needed with every following service.
- Once the installation is complete a thorough road test should be performed to verify proper clearance of all items.
- Revtek Suspension kits are not designed for race applications.
- Altering the suspension on your vehicle may change the characteristics of some systems such as: fuel economy, transmission shift points, etc.
- While Revtek systems are designed to work within all factory specifications and tolerances, there are some situations where exceeding the capability of the vehicle such as load capacity or speed will result in some undesirable results. If you overload your vehicle it will not handle correctly. If you drive or turn with excessive speed your vehicle will handle differently and some onboard vehicle systems may detect this and take appropriate action.
- Our tire and wheel fitments are only a guideline. Different production times or tolerances will vary and this sizes should only be used as a starting point. Each vehicle is different and will need to be treated as such.
- Our lift heights can vary slightly based on manufacturing tolerances. Some vehicles will exhibit slightly different amounts of lift heights and different final heights. Every vehicle is not identical and every vehicle will not be perfectly the same at all four corners.
- Once your vehicle is lifted components may wear faster, this is normal. A lifted vehicle is exerting more stress on most components and therefor causing them to wear faster.
- After altering the height of your vehicle, you should aim the headlights for proper coverage.
- The use of Loctite on fasteners is highly recommended.