



**INSTALLATION INSTRUCTIONS FOR 1999-2004
FORD 4WD SUPER DUTY
2-1/2" SUSPENSION SYSTEM**

Requires the following parts for a complete installation:

- **Front Leaf Springs – P/N 60SD25**
- **Vehicle specific Box Kit depending on vehicle date of manufacture:**
 - MANUFACTURE DATE PRIOR TO 3/99 – P/N 6011B
 - MANUFACTURE DATE 3/1/99 TO 4/1/99 – P/N 6012B
 - MANUFACTURE DATE 4/2/99 TO 12/31/99 – P/N 6012B
(with Square Front U-Bolts)
 - MANUFACTURE DATE 4/2/99 TO 2004 – P/N 6014B
(with Semi-Round Front U-Bolts)
- **REVTEK SUSPENSION PART NUMBER CB35BK IS REQUIRED FOR VEHICLES WITH REAR BLOCKS OTHER THAN FACTORY 3-5/8"**

WARNING!!! READ AND UNDERSTAND ALL INSTRUCTIONS BEFORE PROCEEDING. MAKE SURE THAT YOU HAVE ALL TOOLS AND PARTS BEFORE BEGINNING THE INSTALLATION.

SPECIAL TOOLS REQUIRED:

- TORQUE WRENCH
- FORD SERVICE MANUAL

REVTEK SUSPENSION RECOMMENDS THAT RED LOCTITE BE USED ON ALL FASTENERS UNLESS OTHERWISE NOTED. IT IS ALSO RECOMMENDED TO HAVE THE FRONT END ALIGNMENT CHECKED AFTER INSTALLATION.

GENERAL NOTES:

1. THIS SYSTEM SHOULD ONLY BE INSTALLED BY A PROFESSIONAL.
2. Compare all contents of the boxes to the parts list before starting to insure all components are included.
3. Prior to installing the suspension system, inspect the vehicle's suspension components, alignment, and frame for damage, corrosion, or cracks. Correct any worn or damaged parts before beginning install.
4. Always wear safety glasses during installation
5. On most vehicles, removal of the front bumper may be necessary in order to remove front spring eye bolts.
6. Install all nuts and bolts with a flat washer on both sides.
7. Unless otherwise noted, tighten all bolts to the torque specifications listed in the Torque Specification table included in these instructions. Use a torque wrench.
8. Estimated time to install this system is 3 hours.
9. Suspension components that use rubber or urethane bushings should be tightened with the vehicle at normal ride height. This will prevent premature failure of the bushing and maintain ride comfort
10. Check off the step number at the beginning of each step when you finish it. Then when you stop during the installation, it will be easier to find where you need to continue from.

KIT CONTENTS INCLUDE:

- Instructions including parts list
- Product Safety Label (orange)
- Decal
- Warranty Information

PARTS LIST INCLUDED IN KIT

2-1/2" SUPER DUTY FRONT SPRING	QTY 2
--------------------------------	----------

VEHICLE SPECIFIC BOX KITS

6011B – UP TO 2/28/99

	QTY
1/2 - 13 GRADE C ALL METAL LOCKNUT	1
1/2" FLAT WASHER	2
FRONT SHOCKS	2
REAR SHOCKS	2
1/2 - 13 X 3 1/4 HEX GRADE 8 BOLT (ZINC)	1
9/16 - 12 X 3 1/2 GRADE 8 HEX BOLT (ZINC)	1
9/16 – 12 GRADE C ALL METAL TOP LOCKNUT (ZINC)	1
9/16 FLAT WASHER	8
9/16 FLAT WASHER (ZINC)	2
9/16 HIGH NUT	8
9/16 X 3 1/8 X 9 SQUARE TOP U-BOLT	4
TRACK ARM BRACKET – SM HOLE	1

6012B – 3/1/99 TO 12/31/99 WITH SQUARE FRONT U-BOLTS

1/2 - 13 GRADE C ALL METAL LOCKNUT (ZINC)	1
1/2" FLAT WASHER (ZINC)	2
FRONT SHOCKS	2
REAR SHOCKS	2
1/2 - 13 X 3 1/4 HEX GRADE 8 BOLT (ZINC)	1
9/16 FLAT WASHER	8
9/16 HIGH NUT	8
9/16 X 3 1/8 X 9 SQUARE TOP U-BOLT	4
TRACK BAR BRACKET LG HOLE	1

6014B – 4/1/99 - 2004 WITH SEMI ROUND FRONT U-BOLTS

1/2 - 13 GRADE C ALL METAL LOCKNUT (ZINC)	1
1/2" FLAT WASHER (ZINC)	2
FRONT SHOCKS	2
REAR SHOCKS	2
1/2 - 13 X 3 1/4 GRADE 8 HEX BOLT (ZINC)	1
9/16 FLAT WASHER	8
9/16 HIGH NUT	8
9/16 X 3 1/8 X 9" SEMI ROUND U-BOLT	4
TRACK ARM BRACKET – LG HOLE	1

STANDARD BOLT TORQUE & IDENTIFICATION

INCH SYSTEM			METRIC SYSTEM			
Bolt Size	Grade 5	Grade 8	Bolt Size	Class 9.8	Class 10.9	Class 12.9
5/16	15 ft. lbs.	20 ft. lbs.	M6	5 ft. lbs.	9 ft. lbs.	12 ft. lbs.
3/8	30 ft. lbs.	35 ft. lbs.	M8	18 ft. lbs.	23 ft. lbs.	27 ft. lbs.
7/16	45 ft. lbs.	60 ft. lbs.	M10	32 ft. lbs.	45 ft. lbs.	50 ft. lbs.
1/2	65 ft. lbs.	90 ft. lbs.	M12	55 ft. lbs.	75 ft. lbs.	90 ft. lbs.
9/16	95 ft. lbs.	130 ft. lbs.	M14	85 ft. lbs.	120 ft. lbs.	145 ft. lbs.
5/8	135 ft. lbs.	175 ft. lbs.	M16	130 ft. lbs.	165 ft. lbs.	210 ft. lbs.
3/4	185 ft. lbs.	280 ft. lbs.	M18	170 ft. lbs.	240 ft. lbs.	290 ft. lbs.

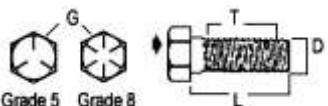
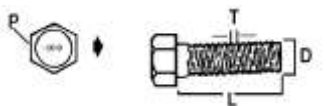
<p>1/2-13x1.75 HHCS</p> <p>D T L X</p>  <p>Grade 5 Grade 8</p> <p>G= Grade Marking (bolt strength) L= Length (inches) D= Nominal Diameter (inches) X= Description (hex head cap screw) T= Thread Pitch (threads per inch)</p>	<p>M12-1.25x50 HHCS</p> <p>D T L X</p>  <p>P= Property Class (bolt strength) L= Length (millimeters) D= Nominal Diameter (millimeters) X= Description (hex head cap screw) T= Thread Pitch (thread width, mm)</p>
---	--

FRONT OF VEHICLE – DISASSEMBLY AND ASSEMBLY

1. Park vehicle on level, hard (concrete) surface.
2. Block the rear wheels of the vehicle to prevent vehicle from moving and set parking brake.
3. Remove front bumper by removing (2) outer 13mm brace bolts and the (4) 18mm bolts from front of bumper.

If the vehicle contains a crash bar below the bumper, it must be removed. To accomplish this, remove the (6) 21mm nuts.

While supporting the bumper, disconnect the (2) lighting harness plugs and wiring harness from bumper, and the 3 plastic push clips in the rubber shield. Carefully remove bumper, making sure not to scratch the paint on the front fenders.



Illustration 1

4. To make access to spring eye bolts, remove (2) 8mm bolts at the lower corner supports of air conditioning cooler and remove supports. See Illustration 1.
5. Remove the track bar bolt 14mm (up to 3/1/99 – discard bolt) or 30 mm (3/2/99 & later – save for later use) on the driver side of the frame mount (see illustration 2), and the tie rod end from the pitman arm.
6. Raise the front of vehicle and support with jack stands on the frame behind the front springs.
7. Remove the front wheels.
8. Support the front axle with a floor jack.
9. Remove front shocks (saving bolts for reinstallation).
10. Carefully bend brake line bracket at frame to horizontal position (see illustration 3).
11. While supporting front differential with a floor jack, remove driver side U-bolts.
12. Remove front driver side leaf spring front nuts (27mm) and rear nuts (21mm), leaving spring eye bolts in place.
13. Lower axle to clear spring. Remove spring bolts and spring.



Illustration 2



Illustration 3

TECH TIP: Factory spring bolts are secured with loctite, which makes removal difficult. By warming the nut with a propane torch to approx. 300 degrees Fahrenheit, the loctite will release and the hardware can be removed with hand tools. (WARNING: Have Fire Extinguisher handy whenever using an open flame on or near any vehicle.)

14. Install new Revtek spring using existing hardware. DO NOT TIGHTEN.
15. Raise axle to spring and secure with new 9/16" U-bolts and nuts supplied, making sure center pin is seated properly.
16. Repeat steps 12 – 15 on passenger side.

FRONT OF VEHICLE – DISASSEMBLY AND ASSEMBLY (Continued)

17. Remove OEM cast track bar bracket on driver side. Save the (2) 15mm bolts for later reuse.

TECH TIP: The two 15mm bolts are secured with loctite, which makes removal difficult. By warming the nut with a propane torch to approx. 300 degrees Fahrenheit, the loctite will release and the hardware can be removed with hand tools. (WARNING: Have Fire Extinguisher handy whenever using a open flame on or near any vehicle.)

18. Install Revtek track bar bracket. Use existing bolts and pal nuts on frame and use new ½” bolt in cross member. Install ½” bolt from front of vehicle and use flat washers under head of bolt and nut. Torque bolts to 90 ft./lbs.
19. Install drag link to pitman arm and torque to specs. (Revtek Industries recommends use of a new cotter pin for installation of drag link.)
20. Install new Revtek shocks, P/N R2615, and torque mounting hardware to specs.
21. Install tires. Set vehicle on ground and torque wheels to factory specs.
22. Tighten spring eye mounting bolts. Torque 18mm spring bolts to 130 ft./lbs. and 16mm spring bolts to 115 ft./lbs.
23. Install track bar into new mount (new 9/16” x 3 ½” bolt nut and washers on vehicles up to 3/1/99) and OEM 30mm bolt for vehicles produced after 3/2/99. Torque to 135 ft./lbs.

TECH TIP: Turning steering slightly will help align bolt.

24. If bumper was removed, reinstall air conditioning cooler supports and then reinstall bumper by reversing steps 3 and 4, then torque to spec.

**FOR VEHICLES NEEDING PART # CB35BK
IF NOT NEEDED, REFER TO STEP 10 ONLY**

REAR OF VEHICLE – DISASSEMBLY AND ASSEMBLY

1. Block front wheels to prevent vehicle from moving in either direction.
2. Lift the truck from the center of the rear differential housing, leaving the jack in place to support the differential.
3. Support the frame with jack stands forward of the rear springs.
4. Remove rear wheels and shocks.
5. Remove the U-bolts on driver side only.
6. Carefully lower the floor jack, creating just enough room to remove the factory block and replace with the Revtek lift block between the spring pad and spring pack with the locating pin facing down. Make sure that the small end of taper on the block faces toward the front of the vehicle.
7. Raise the floor jack slightly; making sure center pin from spring is located in hole.
8. Put in the new U-bolts, washers and nuts supplied in the kit; torque to spec.
9. Repeat step 5 – 8 on passenger side
10. Install Revtek shocks P/N R2917 and torque hardware to specs.
11. Cut off excess u-bolt to prevent body damage, if applicable.
12. Install tires and lower vehicle to ground. Torque wheels to factory specs.
13. CHECKS AND ADJUSTMENTS:
 - Check all hardware for tightness after 100 miles and after off road use.
 - Headlights should be adjusted.
 - Vehicle must be aligned.
14. Test drive vehicle checking for vibration in drive shaft. If vibration occurs, install supplied carrier bearing lowering bracket and hardware. (Some vehicles may require more or less drop to eliminate vibration.)

PRODUCT SAFETY LABEL MUST BE INSTALLED INSIDE CAB

IN PLAIN VIEW OF ALL OCCUPANTS

Important Installation Notes:

- Manufacturing tolerances do create certain variations that we cannot fully account for. At times you may need to use a punch, or pry bar to get holes to line up. Also you may need to slightly enlarge a hole to create a proper alignment. These are all normal situations.
- Altering your suspension may change the way your vehicle handles. Care must be taken to operate your vehicle safely.
- Adding large wheels and tires, will change how your suspension operates. It may put extra strain on certain components causing them to wear sooner than normal.
- While every effort is made to design our kits to work within factory geometry, there are situations where additional alignment tools like adjustable or replacement components may be needed. This is normal.
- It is possible when changing the driveline angles that a vibration may occur, and require an adjustment to repair this situation.
- Other modifications may be needed due to optional equipment on the vehicle or other prior modifications that have been made.
- All fasteners should be checked and retightened after 500 miles. After the initial recheck, they should be checked and tightened as needed with every following service.
- Once the installation is complete a thorough road test should be performed to verify proper clearance of all items.
- Revtek Suspension kits are not designed for race applications.
- Altering the suspension on your vehicle may change the characteristics of some systems such as: fuel economy, transmission shift points, etc.
- While Revtek systems are designed to work within all factory specifications and tolerances, there are some situations where exceeding the capability of the vehicle such as load capacity or speed will result in some undesirable results. If you overload your vehicle it will not handle correctly. If you drive or turn with excessive speed your vehicle will handle differently and some onboard vehicle systems may detect this and take appropriate action.
- Our tire and wheel fitments are only a guideline. Different production times or tolerances will vary and this sizes should only be used as a starting point. Each vehicle is different and will need to be treated as such.
- Our lift heights can vary slightly based on manufacturing tolerances. Some vehicles will exhibit slightly different amounts of lift heights and different final heights. Every vehicle is not identical and every vehicle will not be perfectly the same at all four corners.
- Once your vehicle is lifted components may wear faster, this is normal. A lifted vehicle is exerting more stress on most components and therefor causing them to wear faster.
- After altering the height of your vehicle, you should aim the headlights for proper coverage.
- The use of Loctite on fasteners is highly recommended.