

# RETRAX PRO™

## Installation Instructions

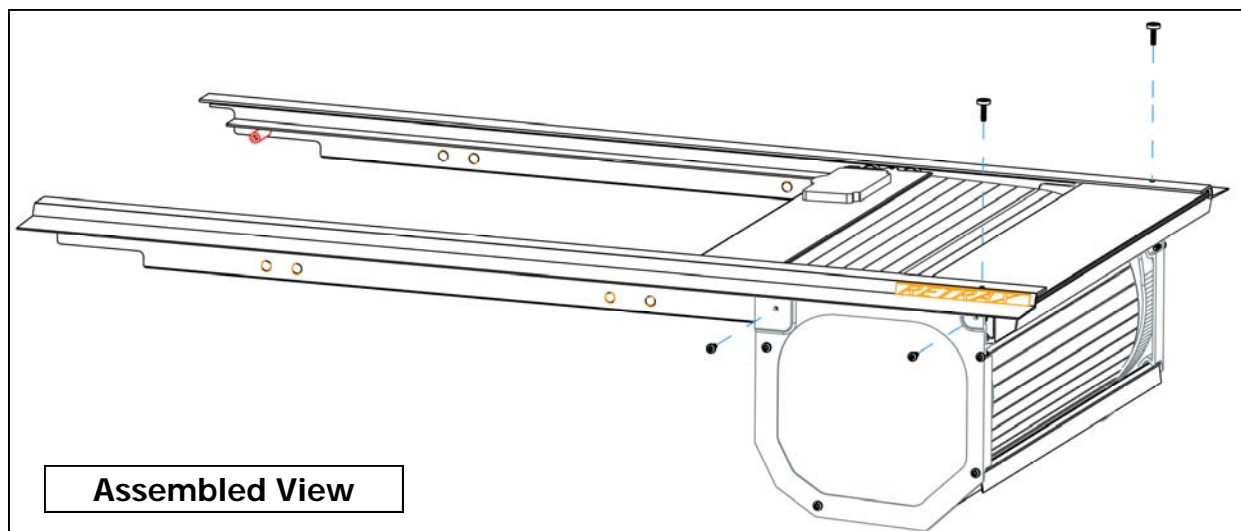
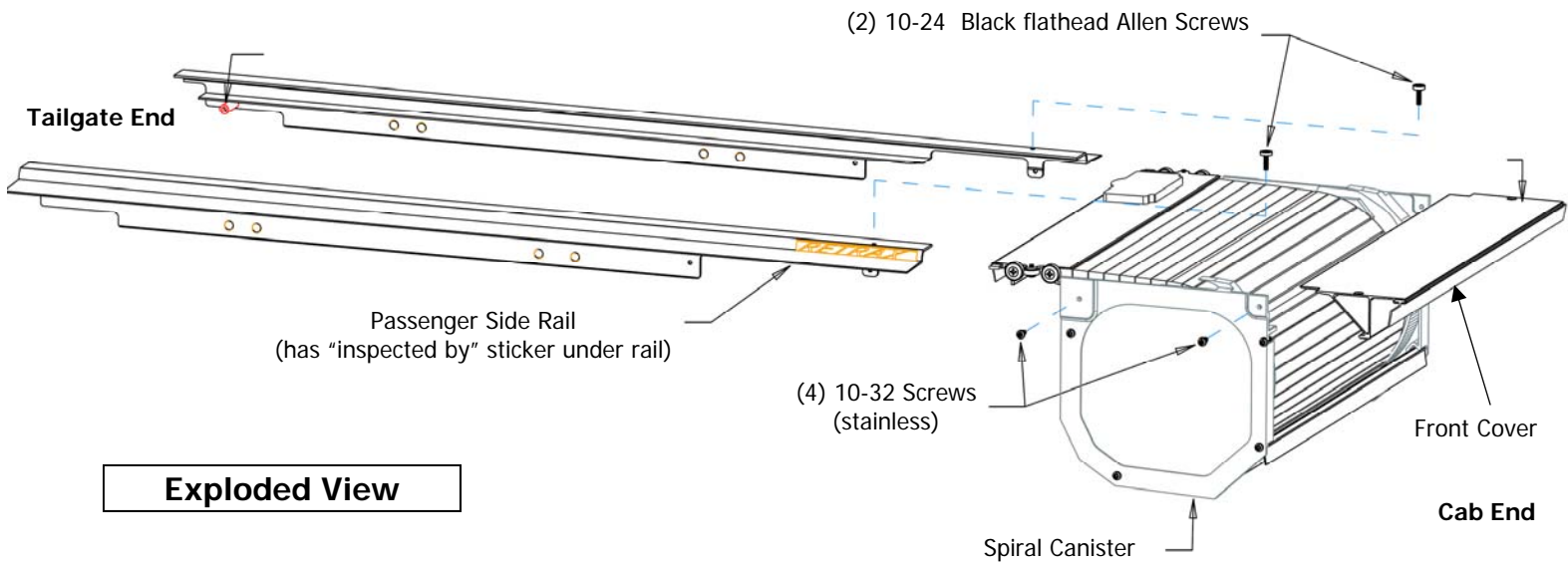

Thank you for your purchase of the **RETRAX<sup>TM</sup>** bed cover system.  
**Please read and follow instructions before un-boxing and assembling the bed cover.**

**Check for shipping damage.**

Keep boxes and packing until installation is complete.

Unpack carefully to prevent scratching.

Remove protective films from cover and canister after installation is complete.

**Remove the protective plastic films before exposing to direct sunlight.**

**Parts checklist for large box**

- Instruction packet with keys
- Cover rolled into canister-spiral assembly
- Front cover for canister (except for Tacoma 5ft models)
- Drain tube kit

**Parts checklist for rail box**

- Driver's side rail
- Passenger side rail
- Clamp box including;
  - (4) **Clamps** (style may differ from photo)
  - (4) **Rail to Canister mounting screws**  
 10-32 x 7/16" Stainless Phillips head
  - (2) **Front Cover mounting screws**  
 10-24 x 3/4" Black Stainless Allen head
  - (1) 1/8" **Allen wrench**
  - (1) **6mm Allen wrench**
  - (1) 1/8" **measuring tool**

**Tools Needed**

- #2 Phillips screwdriver
- 9/16" or 1/2" wrench (ratchet works best)
- Pliers or vice grips



**DO NOT USE LOCTITE!  
 USE OF LOCTITE VOIDS WARRANTY**

**Pre-assembly guidelines**

Two or more people are recommended for installation and you should allow 1 to 1 1/2 hours to complete.  
 Floor space about the size of pickup box is needed for assembly of the bed cover and rails.  
 Clear out the pickup box and clean the front and side bed rails.

**Plastic bed liners may have to be cut or notched at the front of the bed if they touch the rolling cover or interfere with proper canister location.** 2004 to 2008 Ford F-150 and Super Crew plastic bedliners will have to be cut in the front corners for proper canister location and across the front wall of the bed to prevent scratching of the rolling cover. A jig saw with medium tooth blade or a Dremmel or Roto-Zip tool works well. **The front lip of the bed liner may have to be cut off if side bed rail caps are not installed.**

**Drain tubes** (2) 1/2" drain tubes connect to the bottom of canister and can exit out the floor or front of the pickup bed. Some pickups have drain holes in the front of the bed towards each corner; others have plastic or rubber plugs that can be drilled for the tubes. If needed a 1/2" hole can be drilled into both front corners of the box. For pickups equipped with plastic bed-liners, holes for the drain tubes need to be drilled through the plastic only. We recommend drilling additional holes through the floor of a plastic bed liner at the lowest points in front to allow for water drainage.

**STEP 1 Remove the shipping bracket and yellow wire. Completely remove white shipping tubes.**

Shipping tube Shipping bracket  
**Remove these items only!**

The shipping brackets can be disassembled simply by removal of the 10-32 screws fastened to each side of the canister **(Remove this items only)**. The tailgate can then be lifted away from the canister allowing for the removal of the shipping bracket by sliding the T-channel out from the wire ties. The wire ties can then be removed from the bearings without the need for cutting the wire. Pull white shipping tubes completely out of the canister.

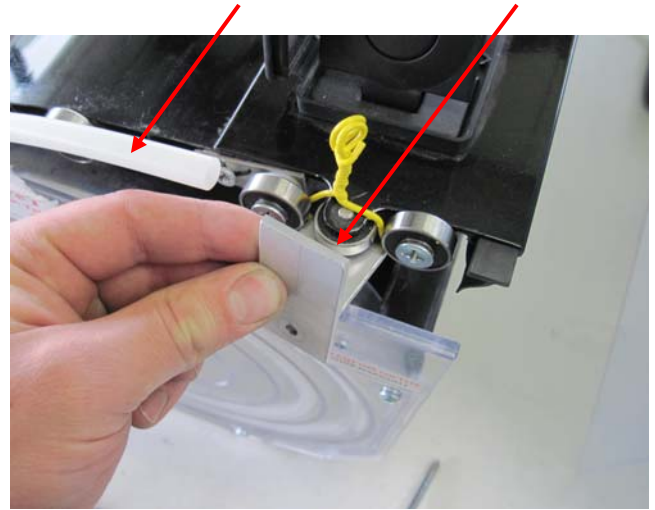

Driver side view of assembly

**DO NOT ALLOW THE COVER TO ROLL INTO THE SPIRAL BECAUSE THE BOTTOM OF THE LOCK CAN DAMAGE**

**STEP 2 Install the passenger rail to the spiral.**

Lift up the lock cover and **open lock** by pressing release button.

Passenger rail has "inspected by" sticker under the front of the rail

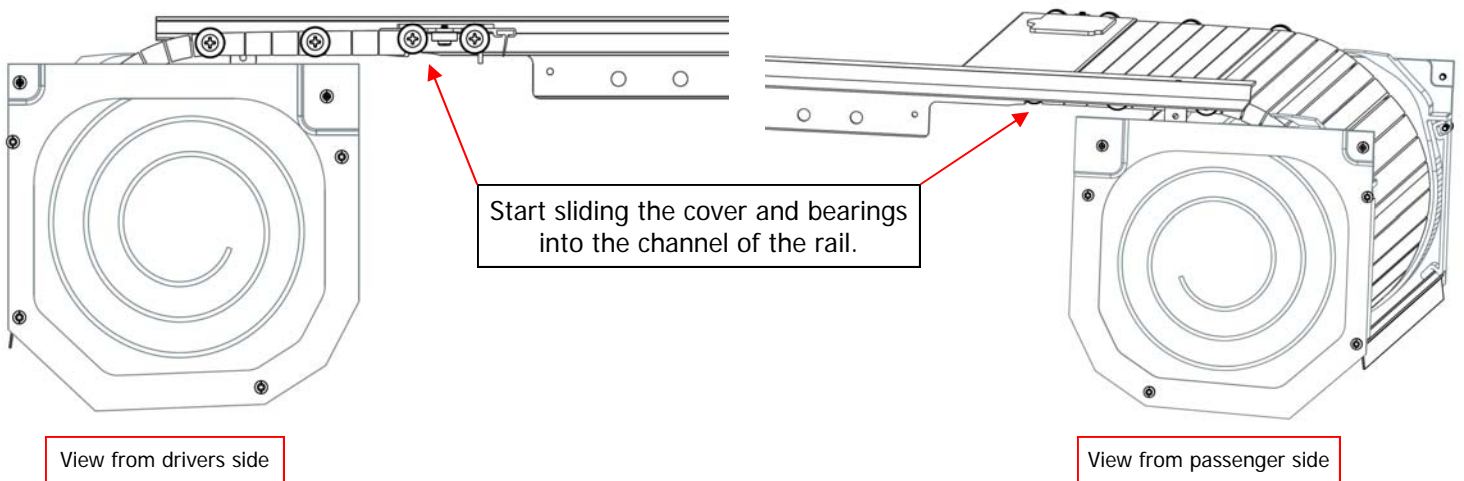

**STEP 2 continued.**

Slide the rail over the cover until the two threaded holes in the rail are lined up **behind** the two holes in the spiral. Attach using two of the **10/32 by 7/16" screws**. **Tighten** using a manual #2 Phillips screwdriver.

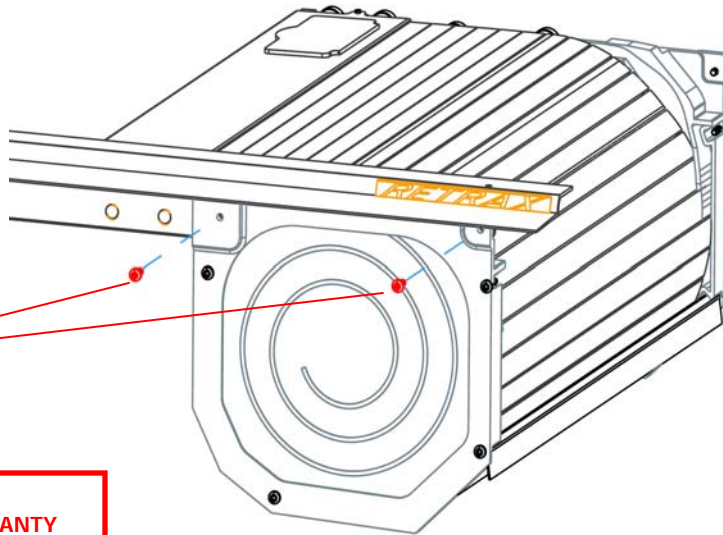

**DO NOT USE LOCTITE!**  
**USE OF LOCTITE VOIDS WARRANTY**

**STEP 3 Install the drivers rail.** Pull the cover out of the canister 6"-8" (**See PowertraxPRO Installation Supplement on how to move electric cover**). **Caution: DO NOT** allow cover to roll back into canister until rail is installed. Repeat Step #2 to install the driver's rail. **Be sure all rail mounting screws are tight.**

During the installation process, make certain the rail weather-strip does not turn under. If this occurs, the rolling cover will become very difficult to move.

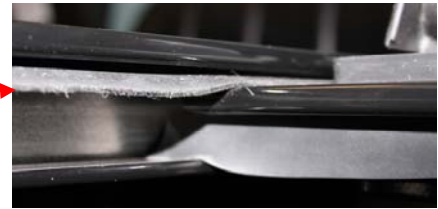

**SIDE VIEW OF FRONT**

**STEP 4 Install the front cover.** The front cover is attached below the rails. Hold the cover level and push both ends in evenly to help slide it into place. When the holes are lined up, start threading the (2) **Front Cover mounting screws**. Tighten the 2 screws securely using the enclosed 1/8" Allen wrench.

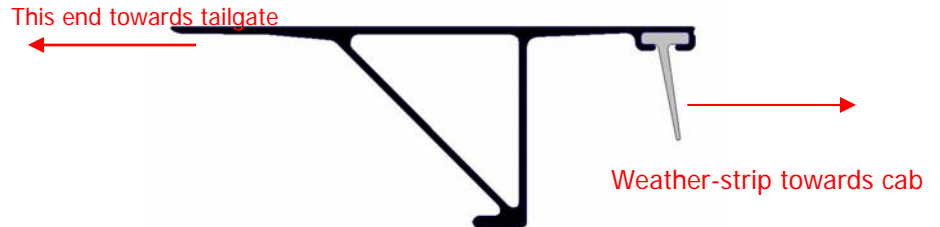

Front cover weather-strip must lay flat across the truck bed. If weather-strip extends past the rails, cut to fit right up to the rail bed capon the truck bed.

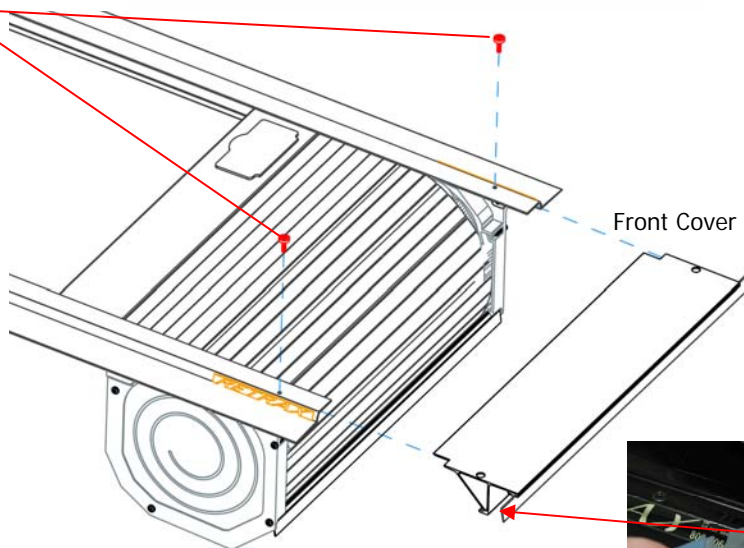



**STEP 5 Lift the assembled cover into the bed.** Roll the cover into the canister and push down firmly on the rounded end of the lock until it latches. Close the tailgate on the pickup. Using two people, lift the bed cover by the front of the rail and two feet to the back. Set the assembly in place at the very front of the bed. **NOTE: The rubber weather-strip on the front cover should lie on top of the pickup's front rail - pointed towards the cab.**

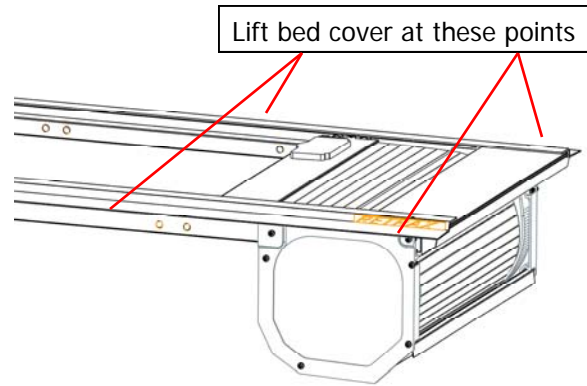

(NOTE: If needed, gently push and twist the rails slightly inward to drop into place. If there are aftermarket bed rail caps or an over the rail spray-in-liner installed, then the white nylon rail adjustment screws may have to be turned counter-clockwise 2-3 complete turns. Turn out **all screws evenly** until the cover drops into place.)

**A latch is found on a Manual cover only. See Power-traxPRO Installation Supplement on how to move electric cover.**

**STEP 6 Position the cover.** Move the rails forward or back to achieve a 1/8" gap between the bottom notch of the rail and the inside face of the closed tailgate or tailgate protector. Measure both sides. Use the supplied 1/8" thick measurement tool to achieve the correct 1/8" gap.



**Note:** Plastic bed liners may have to be cut at the front of bed so the bed cover can be moved forward to achieve proper 1/8" clearance at the tailgate.

**Note:** Keep rails from moving once in position 1/8" from the tailgate.



**STEP 7 Install the front set of clamps.** Start with the two clamps closest to the canister. If your model has two sizes of clamps, the clamps for the front are marked CAB. Proper clamp location is between the two adjustment screws. The adjustment screws are set at different depths depending on your model. These screws may be adjusted later. **DO NOT ADJUST NOW!**



The clamps should be installed as high up as possible to engage more teeth on the rail. Using a 9/16" or 1/2" wrench, tighten the clamps. If the clamp wants to rotate while tightening, hold with pliers or vice-grip.

**STEP 8 Install the rear set of clamps.** Attach the rear set of clamps. Push down on the rail as you tighten the clamp bolts for a better seal on top of the pickup box rails. The rear of the rail may need to be tilted up or down for best fit over the tailgate or tailgate protector.



**STEP 9 Measure the distance between the rails.**  
**The rails must be the same distance apart from each other (parallel) from the front to the rear.** The following steps show how to measure and adjust the rails. Measurements are taken at 3 places starting at the front. The photo to the right shows measurement being taken with a tape measure.

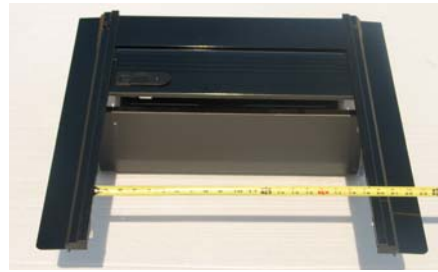

**STEP 9 a.** Measure and record the distance between the rails at **A** - next to front cover screws. This is your base measurement.

**9 b.** Measure and record the distance at **B** above the front clamps. (with clamps tight)

**9 c.** Measure and record the distance at **C** above the rear clamps. (with clamps tight)  
**If the measurements at B and C are not the same as A then adjustments are needed. See STEP 10.**

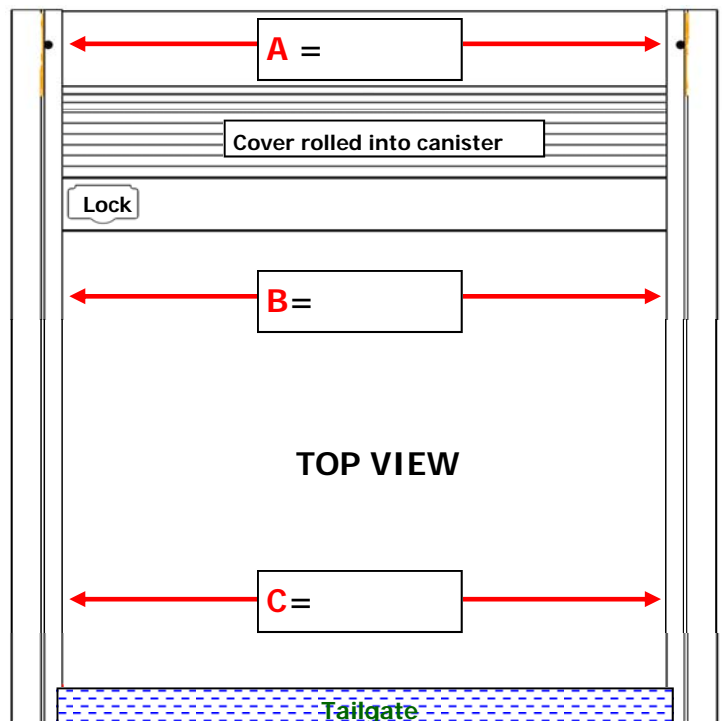

**STEP 10 Adjust distance between the rails.**

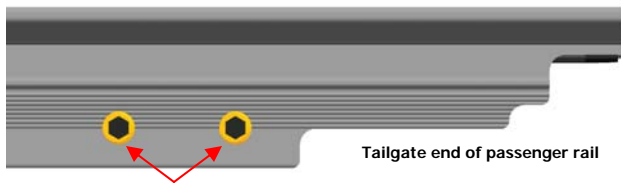

To adjust the distance between the rails, remove the clamp and turn both of the white nylon adjustment screws using a 1/4" Allen wrench.

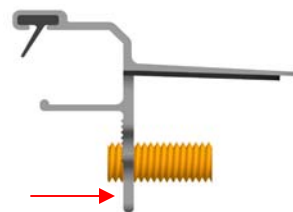

\*If the rails are too far apart, turn the adjustment screws in. (clockwise)

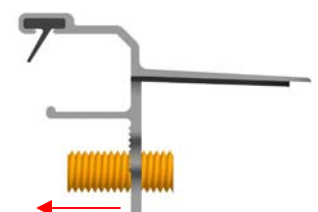

\*If the rails are too close together, turn the adjustment screws out.

One complete turn of the rail adjustment screw equals about 1/16" of adjustment. Adjust the adjustment screws evenly between the driver's and passenger side at each set of clamps.

**Continue adjustments until the distance at points B and C are the same as point A when the clamps are tight.**

**STEP 11** Check for proper fit between the front cover and the rolling cover. Using the lock handle, pull the cover closed over the tailgate and latch. The amount of weather-strip showing at the front of the rolling cover should be close to equal on both the passenger and drivers sides. (Photo shows unpainted parts for clarity) If there is less weather-strip exposed on one side, adjust that rail by removing the clamps and moving that rail towards the cab. Replace the clamps and close the cover. Check again for equal spacing at the front and readjust if needed.

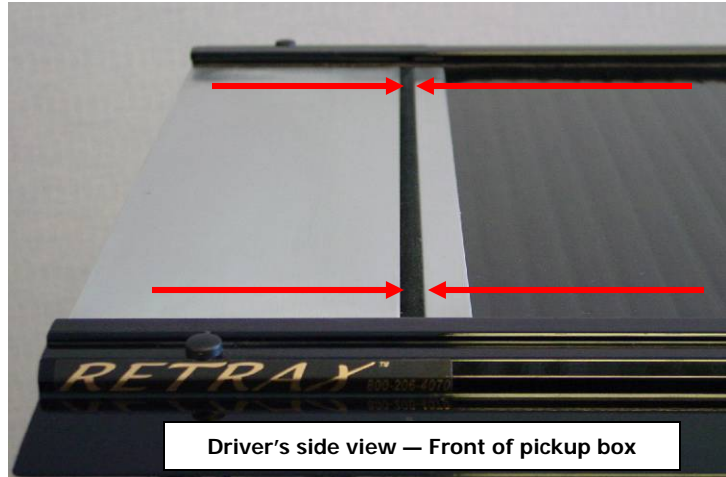

**STEP 12 (a)**

Remove plastic film from the canister. Place the foam washers over the drain tube fittings. Push the assembled tubes into the 2 holes on the bottom of the canister. The fitting should lock into place; test by pulling down on the fitting, it should not pull out of canister.

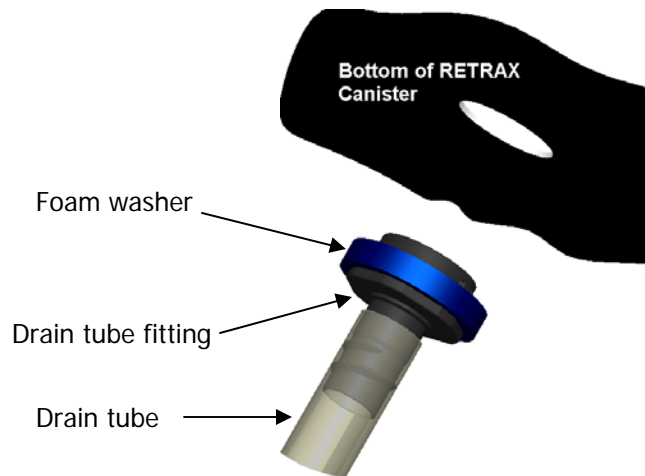

**STEP 12 (b)** Finish Installing the drain tubes. On some models there are factory drain holes in both front corners, on others there are plastic plugs that can be drilled out for the tubes. You can enlarge existing holes or drill new holes in the front wall or floor if needed. Be careful of what is behind when you drill. If using a plastic bed liner, then holes need to be drilled through the liner only. Cut the tubes to length to fit in desired locations.

**STEP 13** Open and close the cover to insure it is rolling without rubbing or binding. Now remove the plastic films from the cover. **(Remove film before exposing to the sun)**

FINAL NOTES: Be sure that all clamps are tight. The top surface of the rails should be level. Loosen the clamp, adjust rail and retighten clamp if needed. **On some models, a better fit over the tailgate or tailgate protector maybe obtained if the rear of the rail is tilted up or down slightly.** You should be able to open and close easily. The rolling resistance will decrease over time as the weather-stripping and bearings break-in.

The lock will push down easily when the cover is completely closed at the tailgate. You also will be able to latch and lock the cover anywhere else along the rail by **pushing down firmly on the rounded end of the lock handle.** In any part way open position; two thumbs may be needed to latch the cover in place. The effort needed to latch the cover will decrease as the lock mechanism takes a set. The lock can be adjusted if needed. At the bottom of the lock is an adjustable steel tip that contacts the rail. To increase or decrease the pressure, adjust the steel tip in or out with a 3/32" Allen (hex) head wrench.

**DO NOT lubricate the bed cover!**

See maintenance on back page

# RetraxPRO MAINTENANCE AND USE INSTRUCTIONS

## USE

The Retrax cover has superior quality, rail weather-strip seals. These seals help minimize water intrusion into the pickup bed. The initial break-in period for the rail weather-strip is about 48 hours in the fully closed position. Your cover may be slightly harder to open and close during the break-in period.

### **Opening and Using the Cover**

Using your **RetraxPRO** cover is as simple as opening the lock cover and pressing the button at the center of the latch to pop open the handle (1). If properly installed, the cover should be able to roll open and closed easily with one hand (2). During the break-in period more effort may be needed, but you still should be able to roll the cover open and closed with one hand.



### **Closing and Locking the Cover**

To latch your **RetraxPRO** cover anywhere along the rail, push down firmly on the end of the lock handle using both thumbs (3). It takes this amount of force because it is a friction lock in any open position. The **RetraxPRO** cover is easier to latch in the fully closed position due to a recess in the rail.



### **Securing Loose Cargo**

**RetraxPRO** covers make transporting loose and large pieces of cargo safe and secure; a unique feature that most tonneau covers cannot claim.

To secure any item too big to fit under the cover, latch the lock handle shut against the item to help keep it in place (4).



## MAINTENANCE & CARE

### **Cleaning and Caring for Your Cover**

Treat your **RetraxPRO** cover like you would treat the hood of your truck; you can wash and wax your cover like you would your pickup. The weatherstripping on your cover may absorb soapy residue from a car wash, so we recommend wiping down the inside of your rails from time to time (5).

### **Important:**

**NEVER** spray any lubricant or cleaner in the rails. This will void your warranty. The ball bearings are sealed and will not need any sort of lubricant or spray.

