

Level of Difficulty

Easy

Parts List

1	License plate bracket
4	Lock washer, M6
4	Flat washer, M6
4	Button head bolt, M6-20
2	Lock washer, M8
2	Flat washer, M8
2	Button head bolt, M8-20
1	Allen wrench, 4mm
1	Allen wrench, 5mm

Product Photo**NOTICE**

Before you begin installation, read all instructions thoroughly.

Proper tools will improve the quality of installation and reduce the time required.

Maintenance

To protect the product, wax after installing. Regular waxing is recommended to add a protective layer over the finish. Do not use any type of polish or wax that may contain abrasives that could damage the finish.

Mild automotive detergent may be used to clean the product. Do not use dish detergent, abrasive cleaners, abrasive pads, wire brushes or other similar products that may damage the finish.

Step 1

Remove the vehicle license plate and factory brackets.

Place the new bracket under the center of the lower cross tube of the bumper guard. The bent edge of the bracket should be facing towards the vehicle.

Attach the bracket with two M8 button head bolts, flat washers and lock washers into the two AVK inserts on the bottom of the center tube of the bumper guard.

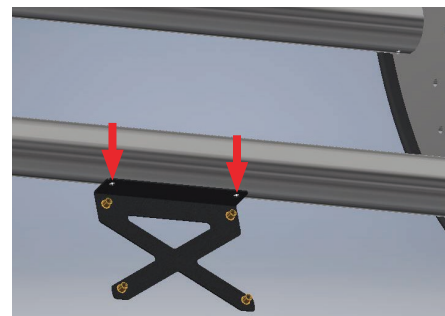
**Step 2**

Secure your license plate to the new bracket with four M6 button head bolts, lock washers and flat washers.

Level and align the license plate, then tighten all hardware.