

READ BEFORE INSTALLATION

The use of any Rennline product is the sole responsibility of the end user. Rennline Inc. accepts no responsibility for warranty voids or damage resulting from the use of these products. Due to the varying location of wiring harnesses and other components, carefully inspect any area prior to drilling. All Rennline products are intended for off road use and should be installed by a qualified automotive technician.

Monoball Strut Mounts - Front

996/986

Check to make sure that you have all parts listed prior to installation.

- Parts List:
- (2) Monoball Strut Mount Assemblies (PN - S20)
 - (1) FK Bearing - COM12T
 - (1) Weather Seal - 964.343.186.80
 - (1) Retaining Ring
 - (4) M4 S/S Button Head Screws - MC92095A189
 - (6) M8X30mm Black S/S Button Head Screw - MC91239A428
 - (6) M8 S/S Washers - MC90965A190
 - (6) M8 S/S nuts - MC90725A715
 - (6) M8 Lock Washers - MC 95060A390
 - (1) Strut Shaft locking tool
 - (2) Step Nut
 - (2) Step Bushing
 - (4) Spacer Bushings

- Step 1 - Install M8 x 30mm bolts as shown here
- Step 2 - Remove factory struts and mounts
- Step 3 - Install strut mounts as shown below
- Step 4 - When installing top step nut, screw on with fingers until the top of the strut shaft exits the nut. Use the supplied tool to hold the strut shaft, then tighten the step nut with a wrench.
- Step 5 - Torque M8 hardware to 20 ft - lbs.
- Step 6 - Align car to your specifications

Note : If you are using struts that have the factory bearing style spring seat, you must discard the weather seal.

- ⊗ - Normal
- - Max Camber

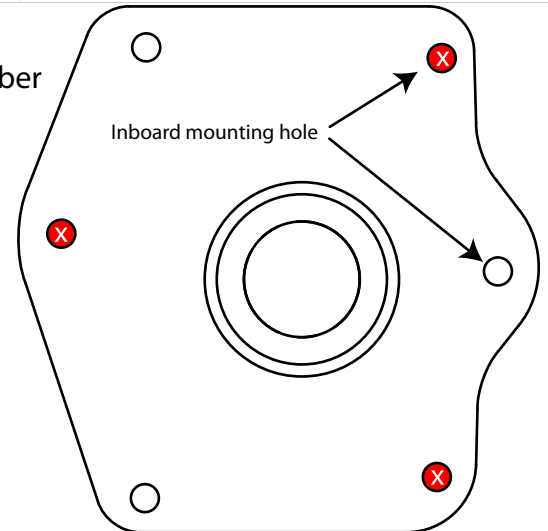

For factory non adjustable struts with factory bearing style spring seat

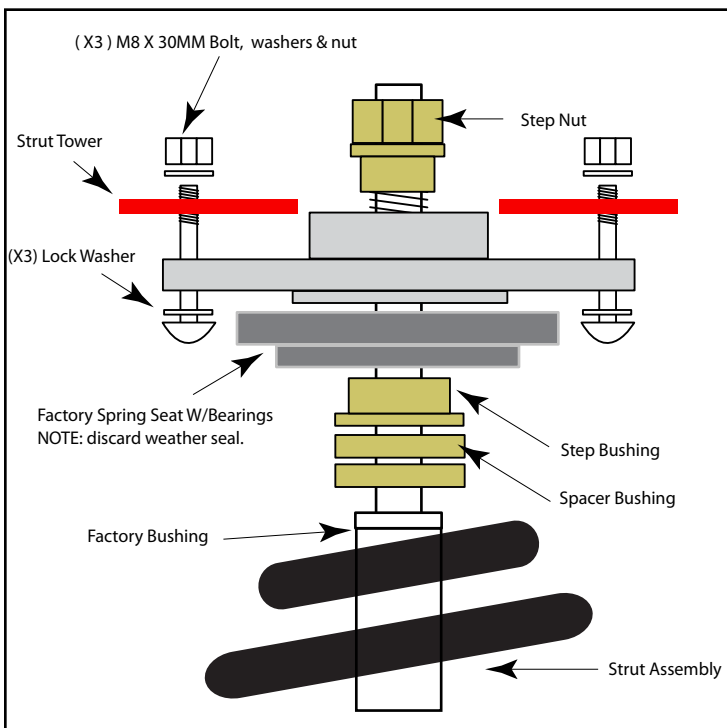

For adjustable struts with spring hats.

