

Installation Instructions

Part Numbers:

25K HITCH

38124N

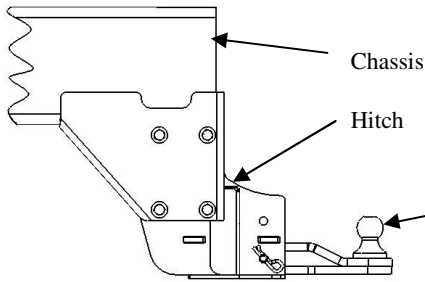

Drawbar Kit:
38124B

Drawbar must be used in the **Drop** position only.

**Do Not Exceed Lower of Towing Vehicle
Manufacturer's Rating or**

25,000 LB (11340 Kg) Max Gross Trailer Weight

4,000 LB (1814.4 Kg.) Max Tongue Weight

Hitch Shown In Proper Position

Equipment Required:

Fastener Kit: N/A

Wrenches: 15/16"

Drill Bits: None

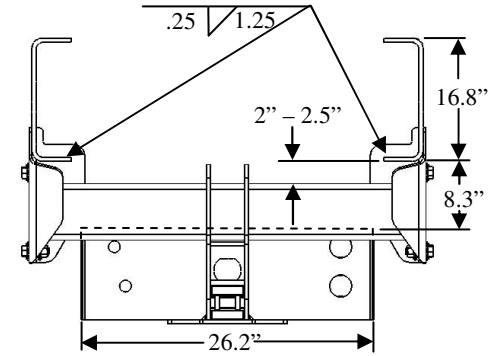
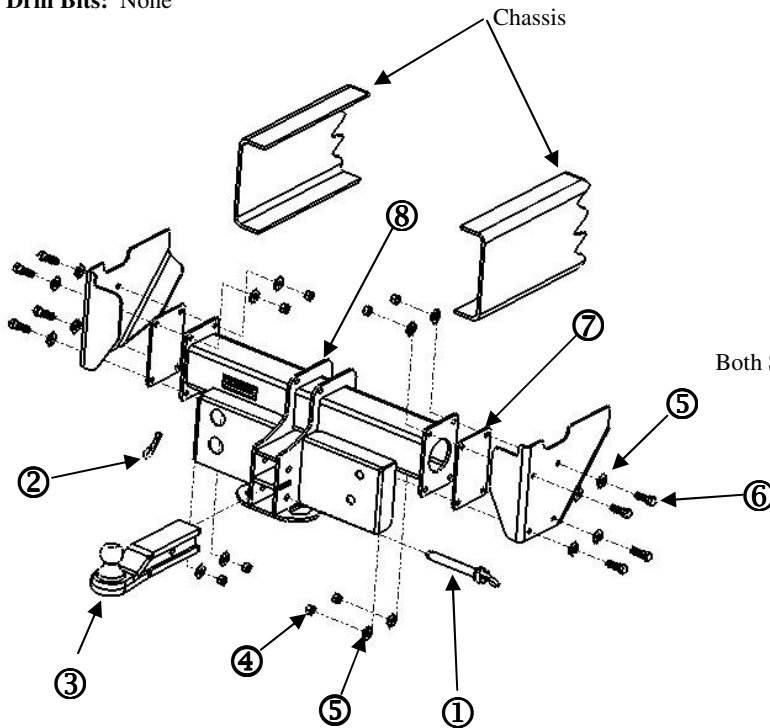

FRONT OF CHASSIS LOOKING REARWARD

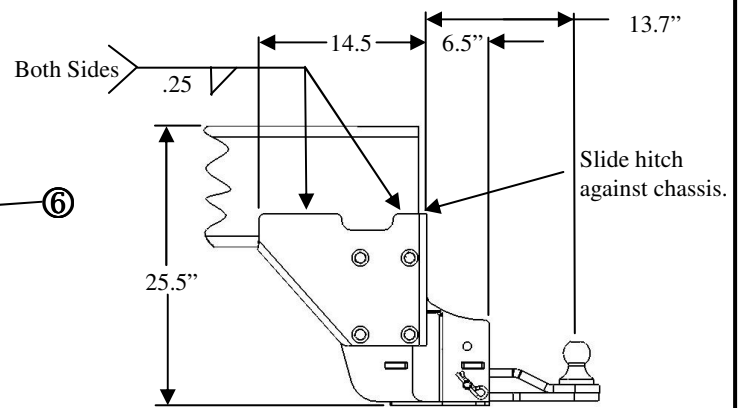

DRIVERS SIDE OF CHASSIS LOOKING AT
THE PASSENGER SIDE

①	Qty. (1)	3/4" Hitch Pin with Lanyard	⑤	Qty. (16)	Conical Washer 5/8"
②	Qty. (1)	Clip	⑥	Qty. (8)	Hex Bolt (5/8" – 11 x 2" Grade 8)
③	Qty. (1)	Drawbar	⑦	Qty. (2)	Spacer Plate
④	Qty. (8)	Hex Nut (5/8" – 11 Grade 8)	⑧	Qty. (1)	Hitch

1. Measure chassis width. If chassis width is under 34.75" then remove shim plates (Item 7). To remove shim plates: remove fasteners (Item 4, 5 & 6). Discard spacer plates (Item 2). Reinstall fasteners and align side brackets. Snug up fasteners.
2. Raise hitch into position. Weld hitch to chassis as shown above.
3. Torque hitch fasteners (Items 4, 5 & 6) to:
Tighten 5/8" – 11 Grade 8 fasteners to 190 lb.-ft. (257.6 N*M)

Note: check hitch frequently, making sure all fasteners and ball are properly tightened. A hitch or ball which has been damaged should be removed and replaced. Observe safety precautions when working beneath a vehicle and wear eye protection. Do not cut access or attachment holes with a torch.