

THE LEADER IN TOWING, TRAILER AND VEHICLE ACCESSORIES



2017 TOWING • TRAILER • VEHICLE ACCESSORIES



Draw-Tite Fulton

Reese

Rola

Tekonsha

Wesbar

2017 PRODUCT CATALOG & APPLICATION GUIDE

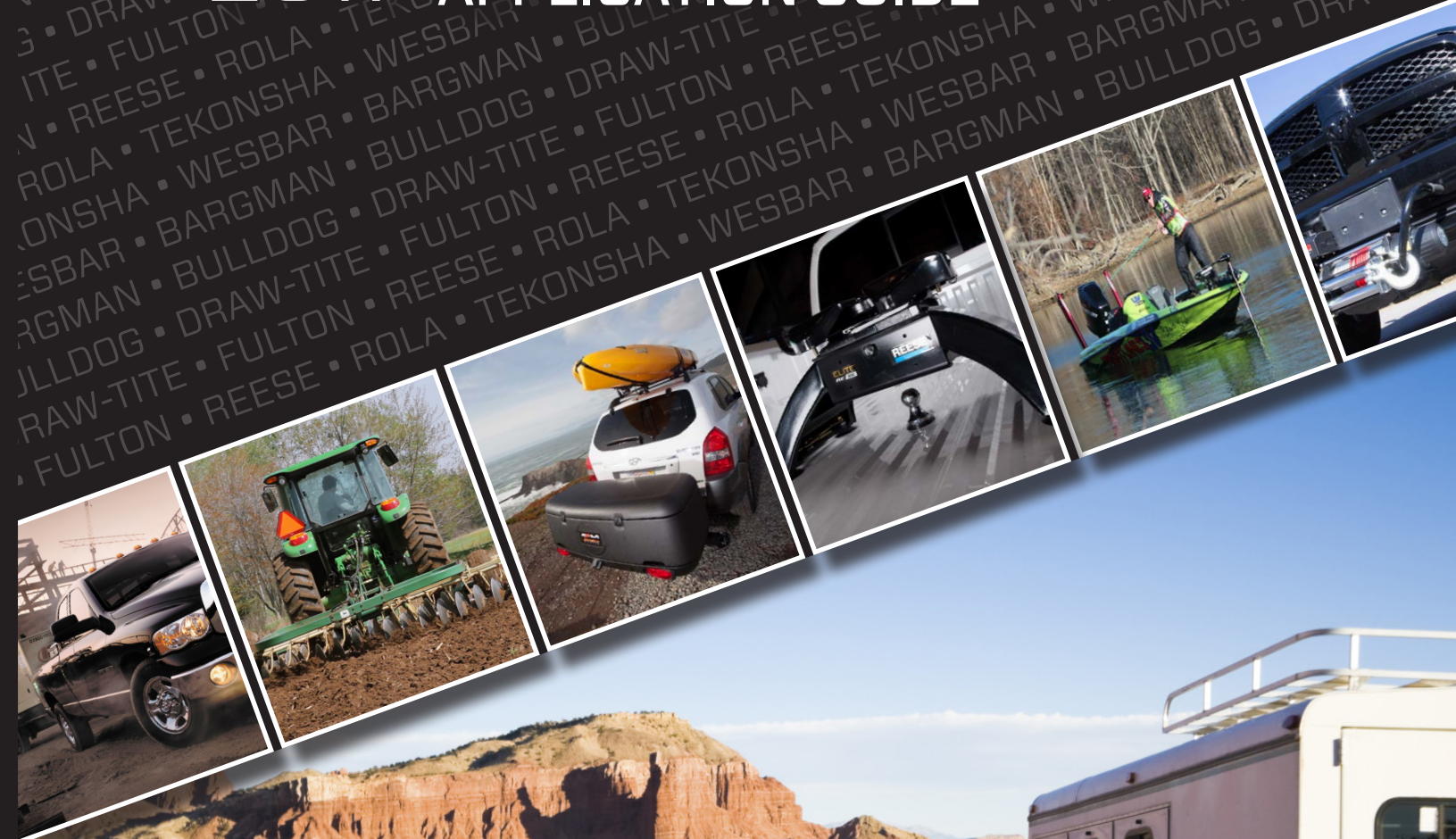

TOWING • TRAILER & VEHICLE ACCESSORIES



Bargman.

Bargman has established itself as a trusted partner, providing a wide range of vehicle electrical connectivity products.



BULLDOG
TOUGH & TRUSTED

BULLDOG products feature a heavy-duty design making them the most "Tough and Trusted" to hold up under rigorous working conditions.



DRAW-TITE

The premier manufacturer of custom trailer hitches. Each hitch must pass rigorous testing to become AMERICA'S BEST®.



FULTON

Fulton Jacks, couplers, winches, and tie down straps combine innovative design, performance, and style with quality and value.



REESE

Known for "Pioneering Performance", Reese offers a complete line of fifth wheel hitches, weight distribution systems and towing accessories.



ROLA

The source for all things cargo management. ROLA helps you transport gear on your roof, hitch, or inside your vehicle, and always in style.



TEKONSHA

The industry leader of electric trailer brake controls and breakaway systems. No matter what you are towing, Tekonsha can help you stop it.



Wesbar

Wesbar provides an extensive variety of lighting and reflector options for agricultural, industrial, marine, recreational, and utility trailers & vehicles.



Product Selectors

Find the right parts for your vehicle

These selectors act as a guide, walking you through the process, step-by-step, with up-to-the-minute information. Populate each category (year, make, model) and watch as the selector presents you with a list of the part(s) to properly fit.



Hitch Selector



Electrical Selector



Front Mount Receiver Selector



Fifth Wheel Selector



Gooseneck Selector



Roof Rack Selector



Select Vehicle Year



Select Vehicle Make



Select Vehicle Model



Select Vehicle Style



Brad Keselowski

Since the age of 14, Keselowski has been a force on the track, creating a large fan base through his aggressive style of racing to his willingness to speak out on an array of topics, most often on social media. In 2007, the NASCAR Sprint Cup Champ formed his own team, Brad Keselowski Racing (BKR), which competes in the NASCAR Camping World Truck Series. Over the last several years, Keselowski's sponsorships with Draw-Tite® and Reese® have allowed BKR to run toward the top of the pack. Keselowski resides in North Carolina with his girlfriend Paige White and their daughter Scarlett.

Brent Chapman

Brent Chapman is a professional bass fisherman on the Bassmaster Elite Series circuit and Major League Fishing, sponsored by Fulton®. He loves being outdoors, and he thanks his father for that. At an early age, Chapman was taught to love and appreciate the outdoors. In 2012, he won Angler of the Year for his superb performance that season. Chapman's also qualified for more than a dozen Bassmaster Classics and has won four Bassmaster tournaments. When he's not mastering the fishing scene, you can find Chapman, his wife Bobbi and their children Mason and Makayla spending time outdoors.



Stacy Westfall

Stacy Westfall is arguably the most well-known horse trainer in the world. Sponsored by Tekonsha®, BULLDOG®, and Reese®, she is the only woman to have won the prestigious Road to the Horse competition, riding bareback and bridleless and was inducted into the National Cowgirl Hall of Fame in 2012. In the late 1990's, Westfall and her husband Jesse established the Westfall Horsemanship training facility in Mt. Gilead, Ohio. After spending a year or so traveling the U.S. in their motorhome, the Westfall's, along with sons Caleb, Joshua, and Nathan, and their horses are building a new home just outside of Wooster, Ohio.

Nick Van Strydonk

Nick Van Strydonk has made quite a name for himself and his team on the ice oval racing circuit. Starting out at an early age, Van Strydonk began racing Kitty Cat and has never looked back. At 16, Van Strydonk won four "World Championships" in one day in Eagle River, Wisconsin - since then, no one has broken the record! Van Strydonk and the T & N Racing team, who are sponsored by BULLDOG® and Fulton®, have made racing a family affair from the start. In 2016-2017, Van Strydonk's cousin Beau will be joining the team. They compete from December through early March in Canada, Wisconsin, Michigan, and Minnesota.



All logos / names / trademarks are copyrights of their respective companies. Reproduction of this catalog (or any part thereof) without the permission of Horizon Global is prohibited by law.



- RECEIVER HITCHES**
- HITCH ACCESSORIES**
- ELECTRICAL WIRING & ACCESSORIES**
- BRAKE CONTROLS**
- WEIGHT DISTRIBUTION SYSTEMS**
- FIFTH WHEEL HITCHES**
- GOOSENECK HITCH SYSTEMS**
- PIN BOXES**
- CARGO MANAGEMENT**
- JACKS / COUPLERS / WINCHES**
- VEHICLE ILLUMINATION**
- AGRICULTURAL**
- TRAILER & VEHICLE ACCESSORIES**
- MERCHANDISING**
- REPLACEMENT PARTS**
- TECHNICAL**
- WARRANTIES**
- NUMERICAL**

NEW PRODUCTS 4-5

RECEIVER HITCHES

First-To-Market Receiver Hitches A-2 / A-3
 Receiver Hitches Class I / II / III / IV A-5 / A-6
 Ultra Frame® Class V Frame A-7
 Heavy Duty Class V Receiver Hitches A-8
 Motorhome / Muilt-fit Receiver Hitches A-9
 Combo Bars / Hitch Tools / Replacement Parts A-10 / A-11
 Front Mounted Receiver Hitches A-12 / A-14
 All-In-One Application Guide A-15 / A-127

HITCH ACCESSORIES

Hitch Balls B-3 / B-5
 Ball Mounts B-7 / B-13
 Pintle Hooks and Accessories B-15 / B-17
 Pins / Clips / Anti-Rattle B-18 / B-19
 Locks / Tube Covers B-20 / B-24

ELECTRICAL WIRING & ACCESSORIES

T-One® Connectors C-5 / C-6
 ModuLite® Power Modules / Converters C-7 / C-14
 2/4/5-Way Flat Connectors and Accessories C-15 / C-19
 6/7-Way Connectors and Wiring C-20 / C-27
 Vehicle / Trailer Adapters / Jumpers C-28 / C-31
 Electrical Accessories C-32 / C-37

BRAKE CONTROLS

Proportional / Timed Brake Controls D-3 / D-9
 Brake Control Accessories / Wiring D-10 / D-11
 Brake Control Wiring Harness Application Guide D-12 / D-14

WEIGHT DISTRIBUTION SYSTEMS

Weight Distribution Systems E-3 / E-13
 Sway Controls E-14
 Weight Distribution Accessories E-15 / E-16

FIFTH WHEEL HITCHES

Fifth Wheel Hitches F-3 / F-15
 Fifth Wheel Hitch Accessories F-18 / F-19
 Fifth Wheel Hitch Application Guides F-4, F-9, F-20 / F-22

GOOSENECK HITCH SYSTEMS

Gooseneck Coupler for RV's G-3
 Gooseneck Hitch Systems & Accessories G-4 / G-10

PIN BOXES

Pin Boxes H-3 / H-8
 Custom Wedges H-9

CARGO MANAGEMENT

Bike Carriers I-3 / I-6
 Cargo Carriers / Cargo Bags I-7 / I-14
 Kayak Carriers I-15
 Truck Rack Systems I-16 / I-18
 Roof Racks I-19 / I-29
 Securing / Nets / Cargo Bars / Accessories I-31 / I-36

JACKS / COUPLERS / WINCHES

Utility Jacks.....	J-5 / J-36
Marine & Recreational Jacks.....	J-29 / J-32
Powered Drive Jacks.....	J-3 / J-4, J-19 / J-21
Couplers.....	J-37 / J-47
Hand Winches.....	J-48-J-56
Power Winches & Hoists.....	J-57-J-64

VEHICLE ILLUMINATION

Tail Lights.....	K-3 / K-20
Auxiliary Lighting.....	K-21 / K-22
Clearance / Side Marker Lights.....	K-23 / K-36
ID Light Bars & Accessories.....	K-37 / K-43

AGRICULTURAL

AG Lighting.....	L-3 / L-5
AG Wiring & Accessories.....	L-6 / L-7
AG Heavy Duty Jack & Couplers.....	L-8 / L-12
AG Goosneck Couplers.....	L-13 / L-15

TRAILER & VEHICLE ACCESSORIES

Breakaway Systems and Accessories.....	M-3 / M-6
Trailer Brake Replacement Parts.....	M-7 / M-18
Wheel Protection.....	M-19 / M-21
Trailer Accessories.....	M-22 / M-27
Vehicle Accessories.....	M-27 / M-28

MERCHANDISING

Product Displays.....	N-2 / N-9
Marketing Materials.....	N-9 / N-13

REPLACEMENT PARTS

Weight Distribution Systems.....	O-2 / O-7
Sway Control.....	O-8 / O-9
Fifth Wheel Hitches.....	WO-10 / O-18

TECHNICAL

Electrical Technical.....	P-2 / P-4
Brake Controls Technical.....	P-5 / P-10
Jacks Technical.....	P-11 / P-15
Power Winch Technical.....	P-17 / P-22
Lighting Technical.....	P-23 / P-29
Trailer Technical.....	P-30 / P-34
Tester Technical.....	P-35 / P-36

WARRANTIES

Installation Indemnification Program.....	Q-2
Warranties.....	Q-3

NUMERICAL

Receiver Hitch Application Numerical.....	Q-4 / Q-21
T-ONE® Application Numerical.....	Q-24 / Q-30
Tow Harness Application Numerical.....	Q-30 / Q-31
Roof Rack Application Numerical.....	Q-38 / Q-43
Truck Bed Application Numerical.....	Q-43
Product Numerical.....	Q-44 / Q-64

RECEIVER HITCHES
HITCH ACCESSORIES
ELECTRICAL WIRING & ACCESSORIES
BRAKE CONTROLS
WEIGHT DISTRIBUTION SYSTEMS
FIFTH WHEEL HITCHES
GOOSENECK HITCH SYSTEMS
PIN BOXES
CARGO MANAGEMENT
JACKS / COUPLERS / WINCHES
VEHICLE ILLUMINATION
AGRICULTURAL
TRAILER & VEHICLE ACCESSORIES
MERCHANDISING
REPLACEMENT PARTS
TECHNICAL
WARRANTIES
NUMERICAL



NEW PRODUCTS



Adjustable Ball Mount Combo Lock Set
Keyed Alike

- Draw-Tite® - 630369
- Page B-12



ZCI™ Zero Contact Interface Universal ModuLite® No Cutting or Splicing Vehicle Wiring

- Tekonsha® - 119250
- Page C-9



7-Way Molded Connector w/Cable, Heavy Duty Cold Weather Insulated Blue Silicon - RV Clocking

- Bargman® - 54006-057
- Page C-23

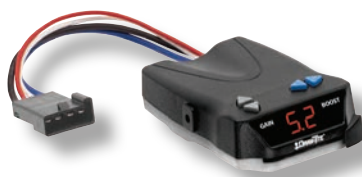

I-Command Electric Brake Control, for 1 to 4 Axle Trailers, Proportional

- Draw-Tite® - 5535
- Page D-7



Steady-Flex® Weight Distributing Kit, Built in Friction Sway Control & Hardware, 10K - 14K lbs. GTW

- Reese® - 66561
- Page E-8



Reese® Outboard Fifth Wheel Brackets, Vehicle Specific Outboard Fifth Wheel Custom Install Brackets

- Reese® - Series 560xx
- Page F-9



10K & 16K Revolution Combo, Replacement for Trailers with OE Revolution

- Reese® - 61510
- Page H-8



Rainproof, Rooftop Cargo Bag Installation Straps Included

- Reese® - 1041100
- Page I-14



Velocity Series™ High Speed Jack, 12K lbs. Capacity, Includes Wired Remote

- BULLDOG® - 185400
- Page J-19



DC Electric Heavy Duty Winch DC9.0, 9K lbs. Capacity, Includes Wire Rope

- BULLDOG® - 500600
- Page J-61



LED Waterproof Over 80" Wrap-Around Taillights, Stainless Steel Mounting Hardware Included

- Wesbar® - 281594 / 281595
- Page K-7



Deluxe Agricultural LED Transport Kit w/Brake Light Function w/46" Wishbone Harness

- Wesbar® - 54003-138
- Page L-4

NEW PRODUCTS



DRAW-TITE®
TESTED TOUGH



RECEIVER HITCHES

FIRST-TO-MARKET HITCHES

2016 - 2017 First-to-Market2-3

HITCH SELECTION

Gross Trailer Weight (GTW) Chart4

RECEIVER HITCHES

Receiver Hitches - Class I and II5

Receiver Hitches - Class III and IV6

Receiver Hitches - Class V7-10

ULTRA FRAME® CLASS V RECEIVERS

Ultra Frame® Class V Receiver Hitches7

Ball Mounts7

Hitch Balls7

Trunnion Style Weight Distribution7

Ultra Frame® Work Truck Hitch7

CLASS V RECEIVER HITCHES

Class V Receiver Hitches8

MOTORHOME RECEIVERS

Multi-Fit Motorhome Hitches9

Universal Motorhome Hitches9

Motorhome Class III Receiver Hitches9

Step Bumper Hitches9

Class III Roll Pan Receiver Hitches9

COMBO BARS

Unpainted Combo Bars10

Painted Combo Bars10

HITCH INSTALLATION TOOLS

Hitch Installation Tools11

FRONT MOUNT RECEIVERS

Front Mount Receivers & Accessories12

APPLICATION GUIDES

Front Mounted Receiver Application Guide13-14

All-In-One Application Guide15-127

FIRST-TO-MARKET HITCHES



24938

2016 CHEVY CAMARO, CLASS I

- 1-1/4" Square Receiver Tube Opening
- Rated up to 2,000 lbs. GTW



36592

2016 CHEVY MALIBU, CLASS I

- 1-1/4" Square Receiver Tube Opening
- Rated up to 3,500 lbs. GTW



24943

2016 CHEVY CRUZE, CLASS I

- 1-1/4" Square Receiver Tube Opening
- Rated up to 2,000 lbs. GTW



24941

2016 CHEVY SPARK, CLASS I

- 1-1/4" Square Receiver Tube Opening
- Rated up to 2,000 lbs. GTW



76015

2016 MERCEDES METRIS, CLASS III

- 2" Square Receiver Tube Opening
- Rated up to 5,000 lbs. GTW



76024

2016 MERCEDES-BENZ GLE350, CLASS III

- 2" Square Receiver Tube Opening
- Rated up to 7,00 lbs. GTW

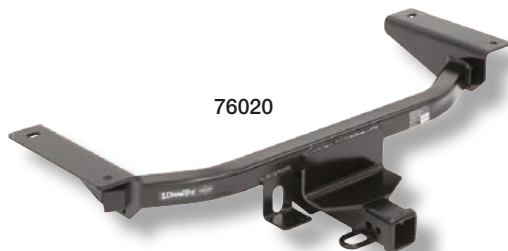

76020

2016 MAZDA CX-9, CLASS III

- 2" Square Receiver Tube Opening
- Rated up to 4,500 lbs. GTW

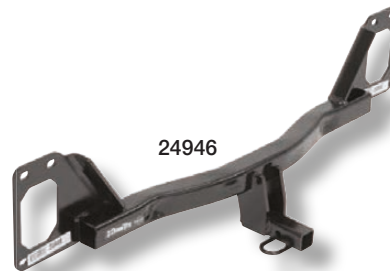

24946

2016 HONDA CIVIC, CLASS I

- 1-1/4" Square Receiver Tube Opening
- Rated up to 2,000 lbs. GTW

FIRST-TO-MARKET HITCHES

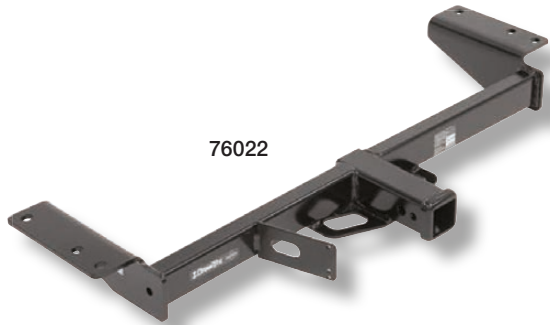

76022

2017 CADILLAC XT5, CLASS III

- 2" Square Receiver Tube Opening
- Rated up to 4,500 lbs. GTW



24939

2017 HYUNDAI ELANTRA, CLASS I

- 1-1/4" Square Receiver Tube Opening
- Rated up to 2,00 lbs. GTW



36798

2017 CHRYSLER PACIFICA, CLASS II

- 1-1/4" Square Receiver Tube Opening
- Rated up to 3,500 lbs. GTW



76023

2017 GMC ACADIA, CLASS III

- 2" Square Receiver Tube Opening
- Rated up to 4,500 lbs. GTW



76076

2017 AUDI Q7, CLASS III

- 2" Square Receiver Tube Opening
- Rated up to 7,700 lbs. GTW



76046

2017 CHRYSLER PACIFICA, CLASS III

- 2" Square Receiver Tube Opening
- Rated up to 4,500 lbs. GTW



36594

2017 BUICK LACROSSE, CLASS I

- 1-1/4" Square Receiver Tube Opening
- Rated up to 3,500 lbs. GTW



24951

2017 CHEVY CRUZE HATCHBACK, CLASS I

- 1-1/4" Square Receiver Tube Opening
- Rated up to 2,000 lbs. GTW



DRAW-TITE CUSTOM BUILT TRAILER HITCHES

- Top quality in every hitch and receiver we make.
- Solid all-welded construction for maximum strength and safety.
- Custom built according to manufacturer vehicle weight specifications and model year to ensure perfect fit and top towing performance.
- All Draw-Tite® hitches meet and exceed V-5 and SAE J684 standards and are inspected for quality and workmanship.
- Computer-aided design and fatigue stress testing ensure a strong design that will withstand road abuse within specified capacities.
- Finish is black powder coat over A-coat (industry leading corrosion resistance).
- Backed by nationwide **Lifetime Limited Warranty**.



SELECTING THE RIGHT HITCH

1. Determine the Gross Trailer Weight and Gross Tongue Weight of the trailer that you would like to tow. Check with the trailer manufacturer or if you are not sure, have it towed to a government inspection scale. Remember that the GTW should reflect a fully loaded trailer.
2. Consult your vehicle’s owner’s manual to determine if your vehicle is rated to safely tow your trailer.
3. Use the CHART BELOW to figure out the minimum “Class” of hitch that is required.
4. Consult a Draw-Tite® dealer to find out which hitches are available for your vehicle.

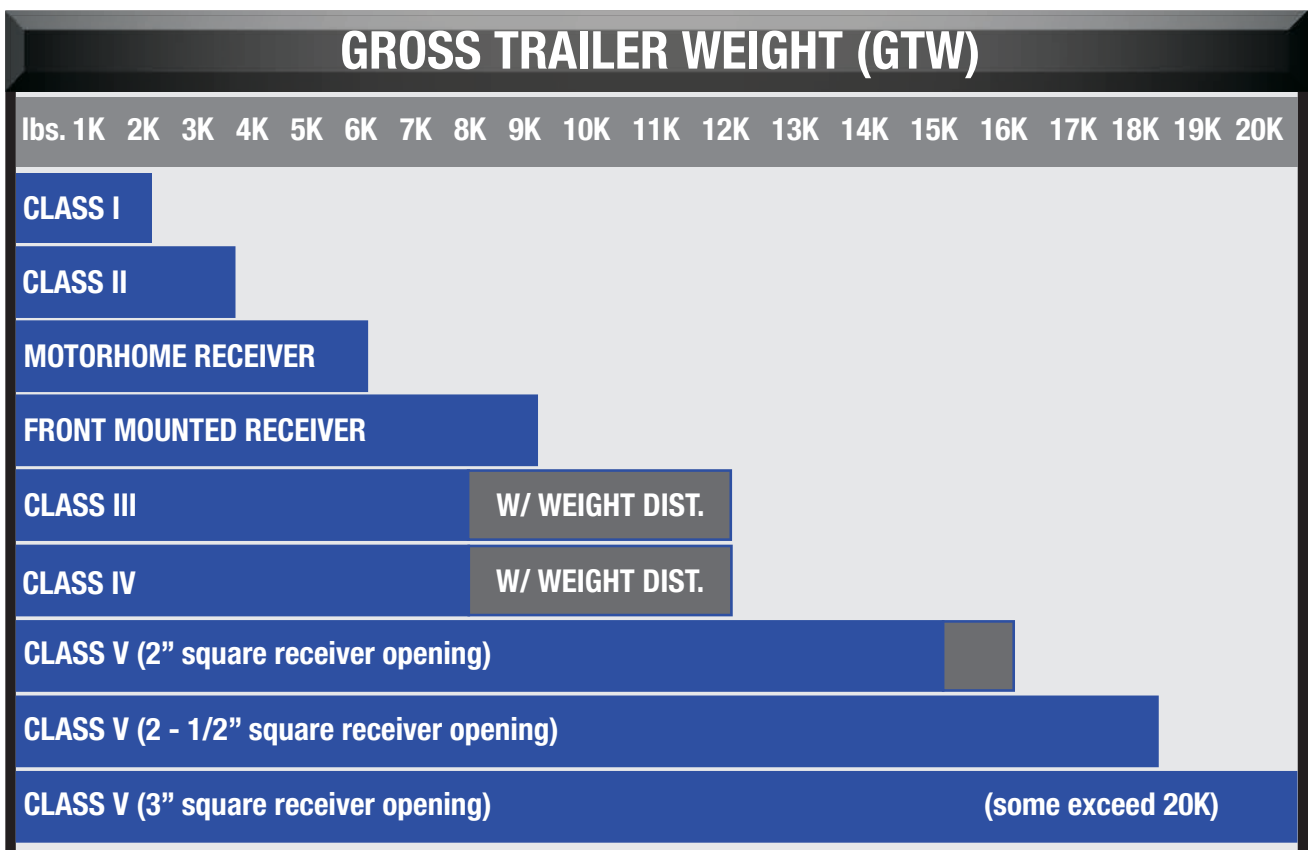

DRAW-TITE GIVES YOU TOP QUALITY IN EVERY HITCH AND RECEIVER WE MAKE:



- Solid all-welded construction for maximum strength and safety
- Custom built according to manufacturer & model year to ensure perfect fit and top towing performance
- Computer-aided design and fatigue stress testing ensure a strong design that will withstand road abuse within specified capacities
- All hitches meet or exceed V-5 and SAE J684 standards and are inspected for quality and workmanship
- Backed by a nationwide limited lifetime warranty
- Black powder coat finish over A-coat



CLASS I SPORTFRAME™ Part No. Series 24XXX

- 1-1/4" square receiver tube opening
- Economical Class I receiver style hitch
- **Removable drawbar, pin and clip sold separately**
- Attaches to vehicle frame and/or bumper
- Black powder coat finish over A-coat



Description	Maximum Rated Capacity	
	Gross Trailer Wt.	Tongue Wt.
Weight Carrying	Up to 2,000 lbs.	Up to 200 lbs.

CLASS II FRAME HITCH™ Part No. Series 36XXX

- 1-1/4" square receiver tube opening
- Receiver style hitch with removable drawbar
- **Removable drawbar, pin and clip sold separately**
- Neat appearance and all frame attachments
- Black powder coat finish over A-coat



Description	Maximum Rated Capacity	
	Gross Trailer Wt.	Tongue Wt.
Weight Carrying	Up to 3,500 lbs.	Up to 300 lbs.

DRAWBAR PROGRAM

WHAT IS THE DRAWBAR PROGRAM?

Horizon Global is proud to present the all new Drawbar Program. Over the years, customers have requested the option of purchasing the Class I and Class II hitch and drawbar separately. Now you can. Like the Receiver Plus Program, the new Drawbar Program offers specially priced drawbars with each Class I or Class II hitch sold. Please note: Discounted pricing is only available on one drawbar kit per hitch, and only when the two are purchased together.

HOW DO I TAKE PART?

1. Choose the correct Class I or Class II hitch part number for the vehicle application.
2. Determine if you need a drawbar (Yes/No)
 - a. If yes, order as follows: Hitch (24824) + Drawbar (3594) = 248240 part number. Adding a "zero" to the end of the number will show that the two parts are being ordered together. The key here is to just add the "zero" to the end of the Class I or Class II hitch part number and we will automatically send you the correct drawbar associated with the hitch.
 - b. If no drawbar is needed, order the standard part number (24824).

**NOW YOU SEE IT,
NOW YOU DON'T!
ONCE INSTALLED THE
INVISIBLE HITCH IS
COMPLETELY HIDDEN
FROM VIEW!**



28351
sold separately 28451
sold separately

CLASS I/II INVISI-HITCH™ Part No. Series 285XX



- 1-1/4" square receiver tube opening
- One piece construction for a stronger hitch and easier installation
- Direct attachment allows hitch to be affixed well under vehicle for minimum visibility when drawbar is removed
- Includes mounting hardware and easy to read instructions
- Removable drawbar & accessory adapter sold separately
- Black powder coat finish over A-coat

Description	Maximum Rated Capacity	
	Gross Trailer Wt.	Tongue Wt.
Weight Carrying	Up to 3,500 lbs.	Up to 300 lbs.



CLASS III/IV SQUARE & ROUND TUBE MAX-FRAME™ RECEIVERS Part No. Series 75XXX

- 2" square receiver tube opening
- Max-Frame receivers are designed for customers with trucks, vans and sport utility vehicles
- Designed for today's stylish sport utility vehicles, round tube receivers complement vehicle appearance
- All frame attachments
- Black powder coat finish over A-coat
- Ball mount, hitch ball, wiring and accessories sold separately
- J-Pin ready
- 75XXX ball mounts #23 and #53 are available (Max-Frame Program)



Description	Maximum Rated Capacity	
	Gross Trailer Wt.	Tongue Wt.
Weight Carrying	Up to 8,000 lbs.	Up to 1,200 lbs.
Weight Distributing	Up to 12,000 lbs.	Up to 1,200 lbs.



CLASS III/IV MAX-E-LOADER™ RECEIVERS Part No. Series 41XXX

- 2" square receiver tube opening
- Max-E-Loader's long side bracket design distributes the towing load over a greater portion of the tow vehicle frame
- All frame attachments
- J-Pin ready
- Black powder coat finish over A-coat

Description	Maximum Rated Capacity	
	Gross Trailer Wt.	Tongue Wt.
Weight Carrying	Up to 6,000 lbs.	Up to 600 lbs.
Weight Distributing	Up to 12,000 lbs.	Up to 1,200 lbs.

QUICK DEFINITIONS

- GTW = Gross Trailer Weight ... Weight of the trailer fully loaded
- TW = Tongue Weight ... Weight exerted by the trailer coupler on the hitch ball
- WC = Weight Carrying ... Tow rating capacity of a hitch without a weight distributing system
- WD = Weight Distributing ... Tow rating capacity of a hitch when using a weight distributing system



CLASS V ULTRA FRAME® RECEIVERS Part No. Series 419XX

- 2" square receiver tube opening
- Designed for full-size long wheelbase trucks, vans and utility vehicles with full frames and heavy-duty suspensions
- Ideal for high tongue weight applications (Example: Toy Hauler)
- Strong, secure heavy-duty side bracket design
- All frame attachments
- J-Pin ready
- Black powder coat finish over A-coat
- Redesign of Ultra Frame® receivers to include Cast Center Section
 - Rugged appearance
 - Cast steel material
 - Bigger chain loops
 - Tighter ball mount fit
 - Reinforced pin hole



ULTRA FRAME® RECEIVERS
With Cast Center Section



Description	Maximum Rated Capacity	
	Gross Trailer Wt.	Tongue Wt.
CLASS V ULTRA FRAME® RECEIVERS		
Weight Carrying	Up to 15,000 lbs.	Up to 1,500 lbs.
Weight Distributing	Up to 16,000 lbs.	Up to 1,600 lbs.
CLASS V ULTRA FRAME® RECEIVERS WITH CAST CENTER SECTION		
Weight Carrying	Up to 16,000 lbs.	Up to 2,400 lbs.
Weight Distributing	Up to 16,000 lbs.	Up to 1,600 lbs.

NOTE: Contact Customer Service for availability of new Cast Center Section part numbers



4907
Side Bracket Kit



4916
Side Bracket Kit



58734
End Caps

ULTRA FRAME® WORK TRUCK HITCH

- Manufactured for Service Body & Flat bed Stake Trucks
- Mix & match Center Section and Side Brackets
- Versatile for various makes and models
- Fabrication Kit Requires Welding
- 41991 Satisfies DOT SEC. 393 .86 (b) (1)

ULTRA FRAME® SERVICE BODY RECEIVERS

Part No.	Description	Maximum Rated Capacity	
		Gross Trailer Wt.	Tongue Wt.
4916	Ultra Frame Receiver, Weld Together For Service Body Trucks Long 16" Side Bracket Kit Only	—	—
4907	Ultra Frame Receiver, Weld Together For Service Body Trucks Short 7" Side Bracket Kit Only	—	—
41990	Ultra Frame Receiver, Weld Together For Service Body Trucks, 44" Crosstube Only	16,000 lbs.	1,600 lbs.
41990-07	Includes 41990 (44") & 4907	16,000 lbs.	1,600 lbs.
41990-16	Includes 41990 (44") & 4916	16,000 lbs.	1,600 lbs.
41991	Ultra Frame Receiver, Weld Together For Service Body Trucks, 62" Crosstube Only	16,000 lbs.	1,600 lbs.
41991-07	Includes 41991 (62") & 4907	16,000 lbs.	1,600 lbs.
41991-16	Includes 41991 (62") & 4916	16,000 lbs.	1,600 lbs.
58374	Ultra Frame Receiver End Caps	—	—



41990
44" Center Section



41991
62" Center Section

HEAVY DUTY CLASS V RECEIVERS Part No. Series 455XX



- 2-1/2" square receiver tube opening
- Designed for full-size long wheelbase trucks, vans and utility vehicles with full frames and heavy-duty suspensions
- Ideal for high tongue weight applications (Toy Hauler & Commercial)
- Strong, secure heavy-duty side bracket design
- All frame attachments
- Pin, clip and receiver tube cover included
- Black powder coat finish over A-coat
- Welded electrical bracket included

Description	Maximum Rated Capacity	
	Gross Trailer Wt.	Tongue Wt.
Weight Carrying	Up to 18,000 lbs.	Up to 2,000 lbs.
Weight Distributing	Up to 18,000 lbs.	Up to 2,500 lbs.

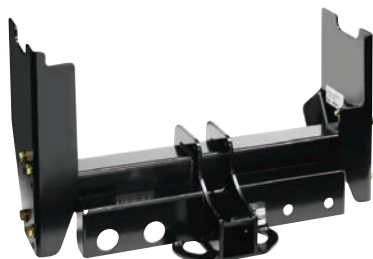

38211

HEAVY DUTY CLASS V 3000 - 20K RECEIVERS

- Large 3" square receiver opening
- 20,000 lbs. weight carry capacity; 3,000 lbs. tongue weight
- Adjustable cross tube for proper height
- Two electrical plug and air brake hook up mounting locations for easy trailer attachments
- Air brake hook up locations
- Dual ball mount w/2 & 2-5/16 balls included
- Pin & clip included
- For frame widths from 33-1/2" to 34-1/2"
- Welds to frame of vehicle

Note: 38023 is 10" from bottom of frame to bottom of receiver tube

Note: 38211 is 14-1/2" from bottom of frame to bottom of receiver tube

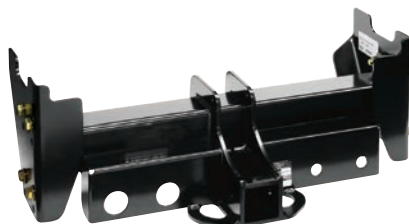

38023

Part No.	Description
38023	3000 20K Weld-On Receiver w/3" Sq. Dual Ball Mount, 2" & 2-5/16" Balls, Includes 3/4" Pin & Clip
38211	3000 20K Weld-On Receiver w/3" Sq. Dual Ball Mount, 2" & 2-5/16" Balls, Includes 3/4" Pin & Clip



38124

HEAVY DUTY CLASS V 4000 - 25K RECEIVERS

- Large 3" square receiver opening
- Rated for 25,000 lbs. weight carry capacity; 4,000 lbs. tongue weight
- Dual stacked receiver tubes for proper height adjustments
- Two electrical plug and air brake hook up mounting locations for easy trailer attachments
- For frame widths from 34" to 34-1/2"
- Air brake fittings for easy trailer hookups
- Dual ball mount w/2 & 2-5/16 balls included
- Pin & clip included

Note: 38124 is 14-1/2" from bottom of frame to bottom of dual stacked receiver tube

Note: 38208 is 10-1/2" from bottom of frame to bottom of dual stacked receiver tube

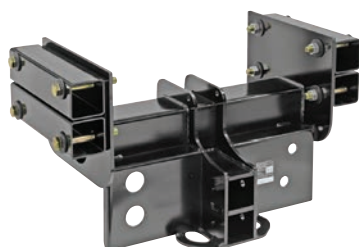

38208

Part No.	Description
38124	4000 25K Weld-On Receiver w/3" Sq. Dual Ball Mount, 2" & 2-5/16" Balls, Includes 3/4" Pin & Clip
38208	4000 25K Bolt-On Receiver w/3" Sq. Dual Ball Mount, 2" & 2-5/16" Balls, Includes 3/4" Pin & Clip



MULTI-FIT MOTORHOME HITCH

- 2" receiver tube accepts all standard utility ball mounts, providing ball height adjustment for level towing
- Simple three-piece construction makes assembly and installation fast and easy
- Attachment hardware included
- J-Pin ready
- Black powder coat finish over A-coat



5350

Part No.	Description
5350	Motorhome Hitch, Adjusts 24"-46" wide 6,000/750 lbs. WD – 5,000/500 lbs. WC

UNIVERSAL MOTORHOME HITCH

- Frame brackets are adjustable



82201

Part No.	Description
82201	Motorhome Hitch, Adjusts 47"-71" wide 3,500/300 lbs. WC

MOTORHOME CLASS III RECEIVER

- Features adjustable brackets to fit different frame widths
- Ideal for Class A & Class C motorhomes
- 2" hitch box opening



36010

Part No.	Description
36010	5,000 WC, universal up to 46" wide

STEP BUMPER HITCHES

- Do not exceed maximum GTW of bumper or hitch
- Not to be used with weight distributing systems
- May require modification or additional spacers for installation on late model pick-ups



81378

Part No.	Description
81378	Class II Step Bumper and Receiver Hitch not for use with weight distributing equipment

CLASS III ROLL PAN RECEIVERS

- Up to 5,000 lbs. / 500 lbs. WC - 7,500 lbs. / 750 lbs. WD
- Designed to fit late model pick-up trucks with factory close-out panels or aftermarket roll pans
- May require cutting of the roll pan
- May require use of a flip-down license plate bracket - not included
- Includes mounting hardware and easy to read instructions



41522

Part No.	Year	Application	Roll Pan Style	O.E.M. or Aftermarket	Through License Plate or Below	Spare tire May Be Retained Under Vehicle Except
41522	88-00	Chevy/GMC Full Size Pickup Old Body Style	1	Aftermarket	Through	P245/75R16, P265/75R16 on short box models only

COMBO BARS



COMBO BARS - UNPAINTED

Designed for use in fabricating undercar receiver hitches when a receiver is not available.

- Made of cold formed structural tubing
- Sized and punched to fit all common weight distributing hitch ball mounts or utility ball mounts



Part No.	Length	Dia.	Ring
2850	6"	2" x 2"	Standard
11081	8"	2" x 2"	Standard
2851	12"	2" x 2"	Standard
2898	18"	2" x 2"	Standard
2852	24"	2" x 2"	Standard
2853	36"	2" x 2"	Standard
2854	48"	2" x 2"	Standard
3006	6"	1-1/4" x 1-1/4"	Standard
5691	12"	2" x 2"	Cast
5692	18"	2" x 2"	Cast
11029	18"	2-1/2" x 2-1/2"	Cast



COMBO BARS - PAINTED

Part No.	Length	Dia.	Ring
80806	6"	2" x 2"	Standard
80812	12"	2" x 2"	Standard
80818	18"	2" x 2"	Standard



40109
40110
6810
6811

DRILL BITS & HOLE SAWS

Drill bits and hole saws are especially selected to best suit trailer hitch installations where drilling is required.

- Drill bits have 135° “split points” for easy starts on flat surfaces
- Made of high carbon, M-2 steel for maximum durability and minimum brittleness
- Bulk packaged



01932-003
01933-003
01934-003
1935

01938-003

1936

1937

Arbor with drill bit

58381

Part No.	Description	Overall Length	Flut Length
01932-003	3/8" Drill Bits (3 per poly bag)	5"	3-5/8"
01933-003	7/16" Drill Bits (3 per poly bag)	5-1/2"	4-1/16"
01934-003	1/2" Drill Bits (3 per poly bag)	6"	4-1/2"
1935	3/8", 7/16", 1/2" Drill Bits (1 set per poly bag)	—	—
1936	1" Hole Saw (1 per poly bag)	—	—
1937	Hole Saw Arbor with pilot drill (1936) (1 per poly bag)	—	—
58381	3-1/2" Hole Saw (1 per poly bag)	—	—
1124	Hole Saw Arbor with pilot drill (58381) (1 per poly bag)	—	—
01938-003	1/4" Pilot Drill Bit (3 per poly bag)	—	—
4655	9/16" Drill Bit with 1/2" shank (1 per poly bag)	6-1/8"	3"
40109	3/8" Rotabroach hole cutting tool with pilot (1 per plastic tube)	—	—
40110	7/16" Rotabroach hole cutting tool with pilot (1 per plastic tube)	—	—
6810	1/2" Rotabroach hole cutting tool with pilot (1 per plastic tube)	—	—
6811	9/16" Rotabroach hole cutting tool with pilot (1 per plastic tube)	—	—



5481
5482
55392
55393

WIRE LOOMS

Part No.	Description
5481	7/16" Wire Forms (20 pack)
5482	1/2" Wire Forms (20 pack)
55392	1/2" Wire Forms for Fishwiring Bolts in Frames (1 piece)
55393	3/8" Wire Forms (1 pack)



74342

HITCH BALL WRENCH

Part No.	Description
74342	Hitch Ball Wrench, boxed end 1-1/8" & 1-1/2"



49803

INSTALL HARDWARE

- Bulk Packaged

Part No.	Description
49803	Fastener Assortment (Carriage bolts, blocks, etc...)



58530



REPLACEMENT PART

Part No.	Description
58530	Replacement Part, Rubber Bolt Cap for #75662, 87530 & 44603



FRONT MOUNTED RECEIVERS

Part No. Series 65XXX

- Up to 9,000 lbs. Line Pull / 500 lbs.TW
- 2" square receiver tube opening
- Front mounted receivers offer a secure and useful attachment point
- All frame attachments
- J-Pin ready
- Ideal for use with winches and snow plows
- Black powder coat finish over A-coat



6495



6980†



6715

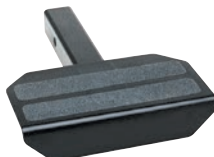

6758



5443



49802



6771

WINCH ADAPTER

Our front mounted receivers are rated for 9,000 lbs. line pull. This makes them ideal for use with BULLDOG® winches. We offer a winch adapter that connects the winch to the receiver. They accept most models of Superwinch, Ramsey and Warn. Will not fit with S-4500 Superwinch.

Part No.	Description
6495	Winch Mounting Plate
6980†	Handle Kit for #6495 Winch Mounting Plate
6985	Replacement Part, Handle Grip for #6980 Handle Kit

SPARE TIRE CARRIER

The spare tire carrier is ideal for relocating spare tires to the front of the vehicle using a front mounted receiver. It has a universal bolt pattern for mounting a variety of tire sizes.

Part No.	Description
6715	Spare Tire Carrier

WORK STEP

The work step is useful for gaining access to engine compartment, particularly with 4WD vehicles. Can also be used on rear Class III/IV receivers.

Part No.	Description
6758	Work Step

LICENSE PLATE ADAPTER

Some States and Provinces require a front license plate. The license plate adapter offers a simple solution where the front hitch interferes with the plate.

Part No.	Description
5443	License Plate Adapter

FOLD DOWN LICENSE PLATE HOLDER

Part No.	Description
49802	Fold Down License Plate Holder

RECEIVER TUBE SKID SHIELD

Off road enthusiasts know what this one is for. It is recommended for use with receivers that are mounted below the bumper.

Part No.	Description
6771	Receiver Tube Skid Shield

† = Available while supplies last.

FRONT MOUNT RECEIVER HITCHES

MODEL / STYLE	YEAR	PC	PART NO.	FOOTNOTES	VERT LOAD	LINE PULL	IN
GMC (Continued)							
Canyon	15-16	23	65071	Ø,X	500	9,000	30
Jimmy Downsize	95-05	24	65004	JW,JXX	300	9,000	30
K1500 2 Dr. Regular & Extended Cabs	88-99	21	65005	JU,JV,KC	500	9,000	40
K1500 4 Dr. Crew Cab	92-99	21	65005	JU,JV,KC	500	9,000	40
K2500 4 Dr. Crew Cab	92-00	21	65005	JU,JV,KC	500	9,000	40
K3500 4 Dr. Crew Cab	92-00	21	65005	JU,JV,KC	500	9,000	40
Savana 1500 Inc. RV Cutaway	96-03	24	65016	X	500	9,000	35
Savana 2500 Inc. RV Cutaway	96-03	24	65016	X	500	9,000	35
Savana 3500 Inc. RV Cutaway	96-03	24	65016	X	500	9,000	35
Sierra 1500 Except Denali (Classic)	99-07	47	65023		500	9,000	20
Sierra 1500	07-13	30	65052	Ø,GP,X	500	9,000	25
Sierra 1500	14-17	30	65064	Ø,GP,X	500	9,000	25
Sierra 1500 HD	01-07	24	65028	HB	500	9,000	20
Sierra 2500	99-04	24	65028	HB	500	9,000	20
Sierra 2500 HD	01-07	24	65028	HB	500	9,000	20
Sierra 2500 HD	07-10	22	65050	Ø,EP,GP,RZ	500	9,000	40
Sierra 2500 HD Except Denali	11-14	26	65068	Ø,GP,EP	500	9,000	45
Sierra 2500 HD Except Denali	15-16	26	65068	Ø,GP,EP	500	9,000	35
Sierra 3500	01-07	24	65028	HB	500	9,000	20
Sierra 3500 HD	07-10	22	65050	Ø,EP,GP,RZ	500	9,000	40
Sierra 3500 HD Except Denali	11-14	26	65068	Ø,GP,EP	500	9,000	45
Sierra 3500 HD Except Denali	15-16	26	65068	Ø,GP,EP	500	9,000	35
Sonoma	94-04	24	65004	JW,JXX	300	9,000	30
Suburban C1500	92-99	21	65005	JU,JV,KC	500	9,000	40
		46	65021	JV,KD	500	9,000	30
Suburban C2500	92-99	21	65005	JU,JV,KC	500	9,000	40
		46	65021	JV,KD	500	9,000	30
Suburban K1500	92-99	21	65005	JU,JV,KC	500	9,000	40
		46	65021	JV,KD	500	9,000	30
Suburban K2500	92-99	21	65005	JU,JV,KC	500	9,000	40
		46	65021	JV,KD	500	9,000	30
Yukon	92-00	21	65005	JU,JV	500	9,000	40
Yukon 1500	00-06	47	65023		500	9,000	20
Yukon	07-14	30	65052	Ø,GP,X	500	9,000	25
Yukon	15-16	30	65064	Ø,GP,X	500	9,000	25
Yukon Denali 1500	01-06	47	65023		500	9,000	30
Yukon XL	15-16	30	65064	Ø,GP,X	500	9,000	25
Yukon XL 1500	00-06	47	65023		500	9,000	20
Yukon XL 1500	07-14	30	65052	Ø,GP,X	500	9,000	25
Yukon XL 1500 Denali	01-06	47	65023		500	9,000	30
Yukon XL 2500	00-06	24	65028	HB	500	9,000	20
HONDA							
Ridgeline	17	27	65073	HM,X,SV	500	9,000	35
ISUZU							
Hombre	96-00	24	65004	JW,JXX	300	9,000	30
JEEP							
Cherokee Downsize	84-01	23	65009	JV	300	9,000	30
Comanche	86-92	23	65009	JV	300	9,000	30
Grand Cherokee	93-98	53	65008	JV	300	9,000	25
Grand Wagoneer	93	53	65008	Ø,JV	300	9,000	25
TJ (Canada Only)	97-06	23	65048	Ø,X	300	9,000	25
Wagoneer	84-90	23	65009	JV	300	9,000	30
Wrangler	87-95	23	65048	Ø,X	300	9,000	25
Wrangler	97-06	23	65048	Ø,X	300	9,000	25
Wrangler Except Models with Adaptable Bumper Design	07-17	19	65069	Ø,EP,GP	500	9,000	40
YJ (Canada Only)	87-95	23	65048	Ø,X	300	9,000	25
LINCOLN							
Mark LT	06-08	22	65043	Ø	500	9,000	20
Mark LT (Mexico Only)	10-13	34	65061	Ø,GP,JV	500	9,000	30
Navigator	98-02	35	65025	Ø	500	9,000	20

MODEL / STYLE	YEAR	PC	PART NO.	FOOTNOTES	VERT LOAD	LINE PULL	IN
MAZDA							
B2300	94-97	52	65017	Ø,JY	300	9,000	35
B2300	02-05	31	65024		500	9,000	35
B2500	01	31	65024		500	9,000	35
B3000	94-97	52	65017	Ø,JY	300	9,000	35
B3000	01-05	31	65024		500	9,000	35
B4000	94-97	52	65017	Ø,JY	300	9,000	35
B4000	01-05	31	65024		500	9,000	35
Navajo	91-94	52	65017	Ø,JY	300	9,000	35
MERCURY							
Mountaineer	02-05	32	65032		500	9,000	30
NISSAN							
Titan 4 WD Only	09-15	44	65065	RB,HM,KG,JW,AL	500	9,000	45
Titan XD	16	30	65072	Ø,EP	500	9,000	25
OLDSMOBILE							
Bravada	96-01	24	65004	JW,JXX	300	9,000	30
RAM							
1500	11-17	32	65062	EP,GP	500	9,000	35
2500	11-17	33	65063	Ø,GP,TY	500	9,000	30
2500 4 WD	11-12	35	65057	EP,GP,JW	500	9,000	40
3500	11-12	38	65060	EP,GP	500	9,000	30
3500	11-17	33	65063	Ø,GP,TY	500	9,000	30
TOYOTA							
Sequoia	01-07	30	65031		500	9,000	40
Tacoma	01-04	31	65041		500	9,000	30
Tacoma	05-16	52	65070	Ø,HM,KG	500	9,000	35
Tundra	00-06	30	65031		500	9,000	40

FOOTNOTES

- † Available while supplies last.
- AA Requires temporary removal of bumper during installation.
- AI Additional installation time may be required.
- AL Additional installation time required for vehicles equipped with load leveling compressor.
- EP Fascia trimming may be required.
- FE Fascia trimming may be required. Allow additional installation time.
- GP Hitch cross-tube concealed behind bumper.
- HB Slight fascia deformation may occur on some models.
- HM Hitch cross-tube is visible beneath bumper.
- JT 2WD models only.
- JU License plate relocation required to install hitch see 5443. (Sold separately)
- JV Rubber air deflector/fascia must be removed or trimmed to install hitch.
- JW 4WD models only.
- JX Requires factory tow hooks for installation on 2WD models.
- JY Extensive fascia cutting required on models w/fog lamp option.
- KB Diesel engine models only.
- KC Does not fit 2500/3500 2WD (C-Series) models w/8 lug wheels.
- KD Fits 2500/3500 2WD (C-Series) models w/8 lug wheels only.
- KE Does not fit 1988-91 4 Dr. Crew Cab models.
- KG Skid shield must be removed or modified if present.
- KI Optional OEM Fog Lights must be removed for receiver installation.
- Ø Uses all existing holes. No drilling required.
- RB Hitch installation can be made easier with a "cutter" type drill bit.
- RZ License plate holder relocation and/or modification required to install hitch (see #49802 or #5443 Sold separately).
- SV Trimming or removal of under body appearance panel may be required.
- TY Requires factory tow hooks for installation.
- X Minor fascia trimming required.

DRAW-TITE HITCH APPLICATIONS

Draw-Tite hitch application look-up enables you to find the right towing system components each and every time. These pages have been developed to simplify the look-up of the proper hitch, drawbar, electrical connectors and wiring locations for your customer's vehicle by make, model and year.

VEHICLE HITCH LOOK UP

MODEL / STYLE	YEAR	PC	REC TYPE	REC SIZE	PART #	NO DRILL	FOOTNOTES	OPTIONAL DRAWBAR	WC (LBS.)	WD (LBS.)	IN											
												TRAILER HITCHES										
												FORD (Continued)										
E-250 Econoline	03-07		19	RT4	2	75703		CSHM		600/6,000	1,000/10,000	20										
			37	SQ5	2	41906		@HMHY		1,000/10,000	1,200/12,000	30										
			35	SQ5	2	41926	Ø	@HM		1,000/10,000	1,200/12,000	30										
			41	SQ5	2	41945	Ø	@HM		1,500/10,000	1,200/12,000	30										
E-250 Econoline	08-08		19	RT4	2	75703		CSHM		600/6,000	1,000/10,000	20										
			37	SQ5	2	41906		@HMHY		1,000/10,000	1,200/12,000	30										
			35	SQ5	2	41926	Ø	@HM		1,000/10,000	1,200/12,000	30										
			41	SQ5	2	41945	Ø	@HM		1,500/10,000	1,200/12,000	30										
E-250 Econoline	09-14		19	RT4	2	75703		CSHM		600/6,000	1,000/10,000	20										
			37	SQ5	2	41906		@HMHY		1,000/10,000	1,200/12,000	30										
			35	SQ5	2	41926	Ø	@HM		1,000/10,000	1,200/12,000	30										
			41	SQ5	2	41945	Ø	@HM		1,500/10,000	1,200/12,000	30										
E-250 Econoline w/Factory 4-Flat (Prepped Class I Towing Package)	09-12																					
E-250 Econoline w/Factory 7-Way (Prepped Class II Towing Package)	09-12																					
E-350 Econoline	95-02		19	RT4	2	75703		CSHM		600/6,000	1,000/10,000	20										
			37	SQ5	2	41906		@HMHY		1,000/10,000	1,200/12,000	30										
E-350 Econoline w/Factory 7-Way	97-02																					
E-350 Econoline	00-02		35	SQ5	2	41926	Ø	@HM		1,000/10,000	1,200/12,000	30										
			41	SQ5	2	41945	Ø	@HM		1,500/10,000	1,200/12,000	30										

1). VEHICLE MODEL/STYLE & YEAR RANGE

Applications are separated first by make, and subsequently by model and yearly divisions.

2). HITCH FOOTNOTES

Footnotes reference additional information pertinent to the installation and availability of a particular hitch. Common footnotes such as "GP" (hitch crosstube concealed behind bumper) are listed at the bottom of each left hand page.

3). DRAW-TITE HITCH PART NUMBERS

Class I, II, III, IV and V receiver hitches are specific for each individual vehicle. This listing indicates the correct hitch by application.

4). DRAWBAR PART NUMBERS

Class I and Class II drawbars are specific for each individual vehicle. This listing indicates the correct drawbar (sold separately) by application.

5). PRICE CODES

Price codes reference specific prices found on Hitch and Accessory Price List.

6). RECEIVER TYPE

Receiver "Type" codes are referenced in a "Receiver Type" footnote box at the bottom of each right hand page.

7). NO DRILL

"Ø" - No drilling requires.

8). RECEIVER WEIGHT RATINGS

WC or Weight Carrying, refers to the total load the hitch is capable of pulling, without the use of a weight distributing system. WD or Weight Distributing, is the total load capacity of the hitch when a weight distribution system is properly utilized.

9). RECEIVER SIZE

Receiver sizes range from 1-1/4" to 3".

10). INSTALLATION TIME

Average installation times (IN) are listed in minutes and are published for all hitches and T-One® wiring connectors. Times are based on common mechanical practices and should be used as an estimate as actual installation times may vary in each individual situation.

11). ELECTRICAL TYPE

Referenced in the footnotes at the bottom of each right hand page, electrical type codes assist in determining the proper electrical wiring products for the towing vehicle.

12). ELECTRICAL POSITIONS

Determining the location of tow vehicle's wiring is becoming increasingly difficult on today's modern vehicles. Note: See Electrical Reference Guide.

VEHICLE ELECTRICAL LOOK UP

Options 1 through 4 offers users several different installation methods when utilizing 4-Flat wiring connectors.

RECEIVER HITCH APPLICATION GUIDE																				
T-ONE					TOW HARNESS					4-FLAT WIRING				REQ. 4 FLAT WIRING		BRAKE CONTROL HARNESS				
PC	T-ONE	FN	IN	AMP	CP	TOW HARNESS	FN	IN	AMP	CP	TYPE	ELEC	POS	CHOICE 1	CHOICE 2	6-WAY ADAPTER	7-WAY ADAPTER	7-WAY HARDWARE	BRAKE CONTROL HARNESS	IN
FORD (Continued)																				
												A	SUV1,2	20252	119180	20320	20321	20224	3035-P	5
E17	118551	CH	45	4,2,7,5	X							A,E	SUV1,2	119180	119148	20320	20321	20224	3035-P	5
E17	118551	CH	45	4,2,7,5	X							A,E	SUV1,2	119180	119148	20320	20321	20224	3034-P	20
						E3	118260	BN	10	7,5		4-Flat	A	SUV6						
						E14	118261	BN	10			7-Way	A	SUV6						
E5	118344	BN	10	7,5								A	SUV1,2	20252	119180	20320	20321	20224	3035-P	5
							118015	RD	10			7-Way	A	SUV6						
							20119	RD	10			Both	A	SUV1,2	20252	119180	20320	20321	20224	3035-P
E5	118344	BN	10	7,5								A	SUV1,2	20252	119180	20320	20321	20224	3035-P	5

13). T-ONE® PART NUMBERS

T-One® part numbers are for vehicle specific applications.

14). TOW HARNESS PART NUMBERS

OEM replacement harness part numbers are for vehicle specific applications with factory tow packages.

15). ELECTRICAL FOOTNOTES

Footnotes reference additional information pertinent to the installation and availability of a particular electrical harness. Footnotes are listed at the bottom of each right hand page.

16). AMPERAGE RATING

Amp Rating references the maximum number of amps the Electrical Product will hold for the tow vehicle.

Stop-Turn Lights - 2 Amps Each

Taillights - 1 Amp Each

Clearance and Marker Lights - 1/4 to 1/2 Amp Each

17). CIRCUIT PROTECTION

Tekonsha recommends circuit protection on vehicles with 3 wire systems for extra safety.

18). OEM CONNECTOR TYPE

Tow Harness Connector type references the type of connector. Example: 4-Flat.

19). HARDWIRE CHOICE 1

The ModuLite® with short circuit protector, adds integrated short circuit protection that safeguards itself and the tow vehicle against harmful electrical shorts and mis-wire situations.

20). HARDWIRE CHOICE 2

Easy do-it-yourself tow vehicle wiring kits.

21). 6-WAY ADAPTERS

Used to convert any trailer wiring component, T-One® or taillight converter with a 4-Flat car end connector to a 6-Way round connector.

22). 7-WAY ADAPTERS

Used to convert any trailer wiring component, T-One® or taillight converter with a 4-Flat car end connector to a 7-Way round connector.

23). 7-WAY HARDWARE

Easy do-it-yourself tow vehicle 7-Way connector wiring kit.

24). BRAKE CONTROL HARNESSES

Brake control harnesses are vehicle specific and designed for quick, easy installation.

RECEIVER HITCH APPLICATION GUIDE

MODEL / STYLE	YEAR	TRAILER HITCHES									
		PC	REC TYPE	REC SIZE	PART #	NO DRILL	FOOTNOTES	OPTIONAL DRAWBAR	WC (LBS.)	WD (LBS.)	IN
ACURA											
CL 3.2	01-03	18	SQ1	1-1/4	24791	0	JR,HM	3592	200/2,000		15
CSX (Canada Only)	06-11	27	SQ1	1-1/4	24861	0	HM,JR,KH,SV	3593	200/2,000		30
EL (Canada Only)	97-01	29	SQ1	1-1/4	24677	0	HM	3593	200/2,000		15
ILX Except Hybrid	13-17	27	SQ1	1-1/4	24861	0	HM,JR,KH,SV	3593	200/2,000		35
Integra	94-01	22	SQ1	1-1/4	24589	0	HM	3593	200/2,000		40
MDX Except w/Full Size Spare Tire	01-06	31	SQ3	2	75599	0	GP,JR		350/3,500	500/5,000	30
MDX Except w/Full Size Spare Tire or w/Rear Sport Bumper Option	07-13	47	RT3	2	75614	0	CR,JR		400/4,000	500/5,000	35
MDX	14-17	37	SQ4	2	75225	0	TA,GP		900/6,000	900/8,000	20
RDX	07-09	22	SQ2	1-1/4	36427	0	GP	36061	300/3,500		15
		33	SQ3	2	75563	0	GP		400/4,000		30
RDX	10-12	19	SQ3	2	75784	0	GP		400/4,000		30
RDX	13-17	19	SQ3	2	75784	0	GP		400/4,000		30
RL 3.5	96-01	41	SQ2	1-1/4	36226		GP	36061	300/3,500		30
RL 3.5	02-04	41	SQ2	1-1/4	36226		GP	36061	300/3,500		30
RLX	14-16	46	SQ2	1-1/4	36541	0	DU,EP,GP,SV,TA	36071	300/3,500		60
RSX	02-06	20	SQ1	1-1/4	24719		TA,GP	3593	200/2,000		30
SLX	96-99	41	SQ3	2	75043		HM		500/5,000	750/7,500	40
TL 3.2	99-03	18	SQ1	1-1/4	24791	0	JR,HM	3592	200/2,000		15
TL	04-08	18	SQ1	1-1/4	24755		TA,GP	3594	200/2,000		35
TL	09-14	19	SQ1	1-1/4	24899	0	HM,JR,KH,SV	3593	200/2,000		45
TLX	16-17	29	SQ1	1-1/4	24942	0	DU,EP,GP,TA	3593	200/2,000		60
TSX 4 Dr. Sedan	06-08	25	SQ1	1-1/4	24768	0	HM,JR	3593	200/2,000		40
TSX 4 Dr. Sedan	09-14	19	SQ1	1-1/4	24899	0	HM,JR,KH,SV	3593	200/2,000		45
ZDX	10-13	27	SQ1	1-1/4	24854	0	GP,I	3590	200/2,000		25
AUDI											
A3 Except Sportback e-tron	15-16	27	SQ1	1-1/4	24930	0	GP	3594	200/2,000		20
A4 4 Dr. Sedan	09-16	29	SQ1	1-1/4	24830	0	EP,GP	3593	200/2,000		25
A4 4 Dr. Sedan	09-17	24	SQ1	1-1/4	24950	0	X,GP,SV	3593	200/2,000		25
A6 4 Dr. Sedan	05-11	25	SQ1	1-1/4	24836	0	HM,JR	3593	200/2,000		25
A6 Quattro Avant Wagon	06-10	25	SQ1	1-1/4	24836	0	HM,JR	3593	200/2,000		25
Q3	13-17	43	SQ3	2	75218	0	DU,EP,GP		450/4,500		50
Q5	11-12	37	SQ3	2	75940	0	DU,EP,GP,TA		750/5,000		60
Q5	13-17	37	SQ3	2	75940	0	DU,EP,GP,TA		750/5,000		60
Q7	07-16	45	SQ4	2	75950	0	AI,GP,X		750/7,500		70
Q7	17-17	34	SQ3	2	76076	0	X,DU,GP		777/7,700		60
BMW											
320i	12-14	24	SQ1	1-1/4	24945	0	DU,GP,SV,KH	3593	200/2,000		50
320i	15-16	24	SQ1	1-1/4	24945	0	DU,GP,SV,KH	3593	200/2,000		50
320i xDrive	12-14	24	SQ1	1-1/4	24945	0	DU,GP,SV,KH	3593	200/2,000		50
320i xDrive	15-16	24	SQ1	1-1/4	24945	0	DU,GP,SV,KH	3593	200/2,000		50
328d	12-14	24	SQ1	1-1/4	24945	0	DU,GP,SV,KH	3593	200/2,000		50
328d	15-16	24	SQ1	1-1/4	24945	0	DU,GP,SV,KH	3593	200/2,000		50
328d xDrive Sedan	12-14	24	SQ1	1-1/4	24945	0	DU,GP,SV,KH	3593	200/2,000		50
328d xDrive Sports Wagon	12-16	24	SQ1	1-1/4	24945	0	DU,GP,SV,KH	3593	200/2,000		50
328d xDrive Sedan	15-16	24	SQ1	1-1/4	24945	0	DU,GP,SV,KH	3593	200/2,000		50
328i Sedan	07-11	43	SQ1	1-1/4	24857	0	GP,SV	3593	200/2,000		45
328i Sedan	12-14	24	SQ1	1-1/4	24945	0	DU,GP,SV,KH	3593	200/2,000		50
328i Sedan	15-16	24	SQ1	1-1/4	24945	0	DU,GP,SV,KH	3593	200/2,000		50
328xi Sedan	07-08	43	SQ1	1-1/4	24857	0	GP,SV	3593	200/2,000		45
335i xDrive Sedan	12-14	24	SQ1	1-1/4	24945	0	DU,GP,SV,KH	3593	200/2,000		50
335i xDrive Sedan	15-16	24	SQ1	1-1/4	24945	0	DU,GP,SV,KH	3593	200/2,000		50
528i	15-16	32	SQ1	1-1/4	24936	0	GP,SV,TA,AA	3593	200/2,000		50

AA Requires temporary removal of bumper during installation.
 AI Additional installation time may be required.
 CR Fits with mini spare tire stowed under vehicle. Will not fit with full size spare.
 DU Fascia removal required.
 EP Fascia trimming may be required.
 GP Hitch crosstube concealed behind bumper.
 HM Hitch crosstube is visible beneath bumper.

I Hitch is positioned further rearward to accommodate spare tire.
 JR Exhaust must be temporarily lowered for installation.
 KH Minor heat shield modification may be required.
 SV Trimming or removal of under body appearance panel may be required.
 TA Trunk access required for hitch installation.
 X Minor fascia trimming required.

RECEIVER HITCH APPLICATION GUIDE

T-ONE						TOW HARNESS						4-FLAT WIRING				REQ. 4 FLAT WIRING			BRAKE CONTROL HARNESS	IN
PC	T-ONE	FN	IN	AMP	CP	PC	TOW HARN	FN	IN	AMP	CP	TYPE	ELEC	POS	CHOICE 1	CHOICE 2	6-WAY ADAPTER	7-WAY ADAPTER		
ACURA																				
E5	118336	HG	5	2.1,5									B	PC3	119130	119178				
													B,E	PC3,4	119148	119180				
													B	PC3	119130	119178				
E18	118627	CH	45	2.1,5,6	X								B,E	PC1,2	119148	119180				
E5	118336	HG	5	2.1,5									B	PC3	119130	119178				
E5	118336	HG	5	2.1,5									B	SUV3	119130	119178	20320	20321	20224	
E11	118424	CH	20	2.1,4,2	X								B,E	SUV1,2	119148	119180	20320	20321	20224	
E11	118628	BN,CH	20	4.2,7,5	X								B,E	SUV3,4	119148	119180	20320	20321	20224	
E11	118500	CH	15	2.1,5,6	X								B,E	SUV1,2	119148	119180	20320	20321	20224	
E11	118500	CH	15	2.1,5,6	X								B,E	SUV1,2	119148	119180	20320	20321	20224	
E14	118569	CH	15	4.2,7,5	X								B,E	SUV1,2	119148	119180	20320	20321	20224	
E5	118336	HG	5	2.1,5									B	PC3	119130	119178				
													B	PC3	119130	119178				
E16	118626	CH	45	2.1,5,6	X								B,E	PC3,4	119148	119180	20320	20321	20224	
													B	PC3	119130	119178				
E5	118339	BN,HG	5	2.1,5									B	SUV5	119130	119178	20320	20321	20224	
E5	118336	HG	5	2.1,5									B	PC3	119130	119178				
E10	118489	HG	10	2.1,7,5									B,E	PC3,4	119148	119180				
E19	118537	CH	45	2.1,5,6	X								B,E	PC3,4	119148	119180				
													B,E	PC1,2	119148	119180				
E11	118302	HG	10	2.1,4,2									B	PC3	119130	119178				
E14	118420	CG	15	2.1,5	X								B,E	PC3,4	119148	119180				
E13	118503	CH	30	2.1,5,6	X								B,E	SUV9	119148	119180				
AUDI																				
													C,E	PC3,4	119180	119148				
													BTT	PC1,2	119251	119191				
													BTT	PC1,2	119192	119191				
													BT	PC1,2	119251	119191				
													BM	PC1,2	119251	119191				
													BT	SUV9	119251	119191				
													BT	SUV1,2	119251	119191	20320	20321	20224	
													A,E	SUV1,2	119148	119180	20320	20321	20224	
													B,E	SUV1,2	119148	119180	20320	20321	20224	
													B,E	SUV1,2	119148	119180				
BMW																				
													B,M	PC3,4	119251	119191				
E23	118713	CH,BN	45	4.2,7,5	X								B,E	PC3,4	119148	119180				
													BM	PC3,4	119251	119191				
E23	118713	CH,BN	45	4.2,7,5	X								B,E	PC3,4	119148	119180				
													BM	PC3,4	119251	119191				
E23	118713	CH,BN	45	4.2,7,5	X								B,E	PC3,4	119148	119180				
													BM	PC3,4	119251	119191				
													BM	PC3,4	119251	119191				
E23	118713	CH,BN	45	4.2,7,5	X								B,E	PC3,4	119148	119180				
													BM	PC3,4	119251	119191				
													BM	PC3,4	119251	119191				
E23	118713	CH,BN	45	4.2,7,5	X								B,E	PC3,4	119148	119180				
													BM	PC3,4	119251	119191				
													BM	PC3,4	119251	119191				
E23	118713	CH,BN	45	4.2,7,5	X								B,E	PC3,4	119148	119180				
													BTT	PC1,2	119251	119191				

- A** 2 wire system.
- B** 3 wire system. Converter required.
- BM** Multiplexed wiring system. ModuLite® HD Plus or Ultra required.
- BN** Exterior mounted plug on some or all models. May require an aftermarket electrical mounting box or bracket. (Sold separately)
- BT** Shared Brake/Tail multiplexed wiring system. ModuLite® HD Plus or Ultra required.
- BTT** Shared Brake/Tail/Turn multiplexed wiring system. ModuLite® HD Plus or Ultra required.

- C** 2 or 3 wire system determine at installation.
- CG** T-One incorporates circuit protected taillight converter.
- CH** T-One is equipped with circuit protected ModuLite® module.
- E** ModuLite® required.
- HG** T-One incorporates taillight converter.
- M** Will fit with heavy-duty suspension.

- RT3** Round Tube Class III 2"
- SQ1** Square Tube Class I
- SQ2** Square Tube Class II
- SQ3** Square Tube Class III
- SQ4** Square Tube Class IV

RECEIVER HITCH APPLICATION GUIDE

MODEL / STYLE	YEAR	TRAILER HITCHES									
		PC	REC TYPE	REC SIZE	PART #	NO DRILL	FOOTNOTES	OPTIONAL DRAWBAR	WC (LBS.)	WD (LBS.)	IN
BMW (Continued)											
528i xDrive	15-16	32	SQ1	1-1/4	24936	0	GP,SV,TA,AA	3593	200/2,000		50
535d	15-16	32	SQ1	1-1/4	24936	0	GP,SV,TA,AA	3593	200/2,000		50
535d xDrive	15-16	32	SQ1	1-1/4	24936	0	GP,SV,TA,AA	3593	200/2,000		50
535i	15-16	32	SQ1	1-1/4	24936	0	GP,SV,TA,AA	3593	200/2,000		50
535i GT	15-16	32	SQ1	1-1/4	24936	0	GP,SV,TA,AA	3593	200/2,000		50
535i GT xDrive	15-16	32	SQ1	1-1/4	24936	0	GP,SV,TA,AA	3593	200/2,000		50
535i xDrive	15-16	32	SQ1	1-1/4	24936	0	GP,SV,TA,AA	3593	200/2,000		50
550i	15-16	32	SQ1	1-1/4	24936	0	GP,SV,TA,AA	3593	200/2,000		50
550i GT	15-16	32	SQ1	1-1/4	24936	0	GP,SV,TA,AA	3593	200/2,000		50
550i GT xDrive	15-16	32	SQ1	1-1/4	24936	0	GP,SV,TA,AA	3593	200/2,000		50
550i xDrive	15-16	32	SQ1	1-1/4	24936	0	GP,SV,TA,AA	3593	200/2,000		50
X1 w/Panoramic Moonroof	13-14	33	SQ3	2	75761	0	GP,JR		400/3,500	400/4,000	60
X1 w/Panoramic Moonroof	15-15	33	SQ3	2	75761	0	GP,JR		400/3,500	400/4,000	60
X1	16-16	25	SQ3	2	76018		GP,JR,DU,KH		675/4,500	675/4,500	40
X1	17-17	25	SQ3	2	76018		GP,JR,DU,KH		675/4,500	675/4,500	40
X3	04-10	25	SQ3	2	75371		AA,EP		350/3,500	400/4,000	100
X3	11-17	36	SQ3	2	75768	0	GP,SV		400/3,500	400/4,000	90
X5	00-06	28	SQ4	2	75492		AA,EP		600/6,000	600/6,000	60
X5 Except M Sport Package	07-17	51	SQ4	2	75600	0	AA,EP,GP		600/6,000	600/6,000	75
BUICK											
Allure (Canada Only)	05-09	37	SQ2	1-1/4	36374		GP,JR	36061	300/3,500		30
Century Sedan	97-05	24	SQ1	1-1/4	24659		TA,GP	3592	200/2,000		30
		37	SQ2	1-1/4	36374		GP,JR	36061	300/3,500		30
Enclave	08-12	19	RT3	2	75528	0	GP,JR,TN		750/5,000	750/7,500	25
Enclave w/Factory 7-Way	08-12										
Enclave	13-17	19	RT3	2	75528	0	GP,JR,TN		750/5,000	750/7,500	25
Encore	13-16	25	RT2	1-1/4	36554	0	HM,JR	36061	300/3,500		40
Encore	17-17	25	RT2	1-1/4	36554	0	HM,JR	36061	300/3,500		40
Envision	16-17	24	SQ4	2	76080	0	AA,DU,GP,TA		675/4,500		45
LaCrosse Except Super	05-09	37	SQ2	1-1/4	36374		GP,JR	36061	300/3,500		30
LaCrosse	10-13	49	SQ2	1-1/4	36522		HM	36061	300/3,500		25
LaCrosse	10-16	42	SQ2	1-1/4	36538	0	HM	36061	300/3,500		35
LaCrosse	14-14	47	SQ2	1-1/4	36546	0	HM	36061	300/3,500		30
LaCrosse	17-17	23	SQ2	1-1/4	36594	0	GP,JR,AA,DU,X,TA	36071	300/3,500		80
LeSabre FWD	97-99	43	SQ2	1-1/4	36216		GP,JR	36061	300/3,500		40
LeSabre	00-05	39	SQ2	1-1/4	36309		HM,JR	36063	300/3,500		30
Lucerne Except Super & Special Edition	06-09	39	SQ2	1-1/4	36309		HM,JR,KH	36063	300/3,500		30
Lucerne Super & Special Edition	08-09	25	SQ2	1-1/4	36502	0	HM,JR	36063	300/3,500		25
Lucerne	10-11	25	SQ2	1-1/4	36502	0	HM,JR	36063	300/3,500		25
Park Avenue	97-04	47	SQ2	1-1/4	36245		JR,GP	36061	300/3,500		40
Rainier w/Factory 7-Way	04-07										
Regal (App. starts with 97-1/2)	97-04	27	SQ1	1-1/4	24660	0	TA,GP	3594	200/2,000		20
		51	SQ2	1-1/4	36241		JR,GP	36065	300/3,500		35
Regal	11-13	42	SQ2	1-1/4	36538	0	HM	36061	300/3,500		35
Regal Except GS	11-13	49	SQ2	1-1/4	36522	0	HM	36061	300/3,500		20
Regal	14-17	42	SQ2	1-1/4	36538	0	HM	36061	300/3,500		35

AA Requires temporary removal of bumper during installation.
DU Fascia removal required.
EP Fascia trimming may be required.
GP Hitch crosstube concealed behind bumper.
HM Hitch crosstube is visible beneath bumper.
JR Exhaust must be temporarily lowered for installation.

KH Minor heat shield modification may be required.
SV Trimming or removal of under body appearance panel may be required.
TA Trunk access required for hitch installation.
TN Hitches produced before 07/09/12 are rated at 500/5000 WC & 500/5000 WD.
X Minor fascia trimming required.

RECEIVER HITCH APPLICATION GUIDE

B

BUICK

T-ONE						TOW HARNESS						4-FLAT WIRING				REQ. 4 FLAT WIRING			BRAKE CONTROL HARNESS	IN			
PC	T-ONE	FN	IN	AMP	CP	PC	TOW HARN	FN	IN	AMP	CP	TYPE	ELEC	POS	CHOICE 1	CHOICE 2	6-WAY ADAPTER	7-WAY ADAPTER	7-WAY HARDWIRE	BRAKE CONTROL HARNESS	IN		
BMW (Continued)																							
													BTT	PC1,2	119251	119191							
													BTT	PC1,2	119251	119191							
													BTT	PC1,2	119251	119191							
													BTT	PC1,2	119251	119191							
													BTT	PC1,2	119251	119191							
													BTT	PC1,2	119251	119191							
													BTT	PC1,2	119251	119191							
													BTT	PC1,2	119251	119191							
													BTT	PC1,2	119251	119191							
													BTT	PC1,2	119251	119191							
													BTT	PC1,2	119251	119191							
													BTT	PC1,2	119251	119191							
													BTT	PC1,2	119251	119191							
E23	118717	BN	45			X							BM	SUV1,2	119251	119191	20320	20321	20224				
E23	118717	BN	45			X							B,E	SUV1,2	119251	119191	20320	20321	20224				
													B,E	SUV1,2	119251	119191	20320	20321	20224				
													B,E	SUV1,2	119251	119191	20320	20321	20224				
													BM	SUV3,4	119251	119191	20320	20321					
													BM	SUV1,2	119251	119191	20320	20321	20224				
													BT	SUV3,4	119251	119191	20320	20321					
													E	SUV3,4	119180	119148	20320	20321	20224				
BUICK																							
													A	PC3,4	119180	20252							
													A	PC3,4	119180	20252							
E7	118450	BN	10	7.5			E8	118384	BN,RD	5	7.5	4-Flat	N	SUV1,2		119251	20320	20321			3026-P	5	
							E12	22111 20047 118015	BN RD RD	25 5 10		7-Way 7-Way 7-Way	N	SUV1,2		119251						3026-P	5
E10	118270	BN	20	7.5			E16	118271	BN	20		7-Way	B,E	SUV1,2	119148	119180	20320	20321	20224		3026-P	5	
E16	118588	CH	45	4.2,7.5		X							B,E	SUV3,4	119148	119180	20320	20321					
E5	118725	BN	15	7.5		X							A	SUV5	119180	20252							
E7	118479		10	7.5									A	PC3,4	119180	20252							
E18	118497	CH	45	2.1,5.6		X							B,E	PC1,2	119148	119180							
E18	118497	C,H	45	2.1,5.6		X							B,E	PC3,4	119148	119180							
E18	118497	CH	45	2.1,5.6		X							B,E	PC1,2	119148	119180							
													A,E	PC3,4									
													A	PC3,4	119180	20252							
													A,E	PC3,4	119148	119180							
E5	118419		10	7.5									A	PC3,4	119180	20252							
E5	118419		10	7.5									A	PC3,4	119180	20252							
E5	118419		10	7.5									A	PC3,4	119180	20252							
													B	PC3,4	119130	119178							
							E8	118384 20119 20047 118015	BN,RD RD RD RD	5 10 5 10	7.5	4-Flat Both 7-Way 7-Way	H	SUV6	119180	20252							
													A	PC3,4	119180	20252							
E18	118504	CH	45	2.1,5.6		X							A,E	PC3,4	119148	119180							
E18	118504	CH	45	2.1,5.6		X							A,E	PC1,2	119148	119180							
E18	118639	CH	45	2.1,5.6		X							B,E	PC3,4	119148	119180							

- A** 2 wire system.
- B** 3 wire system. Converter required.
- BM** Multiplexed wiring system. ModuLite® HD Plus or Ultra required.
- BN** Exterior mounted plug on some or all models. May require an aftermarket electrical mounting box or bracket. (Sold separately)
- BT** Shared Brake/Tail multiplexed wiring system. ModuLite® HD Plus or Ultra required.
- BTT** Shared Brake/Tail/Turn multiplexed wiring system. ModuLite® HD Plus or Ultra required.
- C** 2 or 3 wire system determine at installation.
- CH** T-One is equipped with circuit protected ModuLite® module.
- E** ModuLite® required.
- H** 3 wire system with OEM standard 2 wire harness.
- N** DO NOT cut or splice vehicle wiring. Only use approved T-One or see auto dealer for trailer tow wiring kit.
- RD** For vehicles equipped with factory tow package may require additional components or may be used as a replacement harness.

- RT2** Round Tube Class II 1-1/4"
- RT3** Round Tube Class III 2"
- SQ1** Square Tube Class I
- SQ2** Square Tube Class II
- SQ3** Square Tube Class III
- SQ4** Square Tube Class IV

RECEIVER HITCHES

RECEIVER HITCH APPLICATION GUIDE

MODEL / STYLE	YEAR	TRAILER HITCHES									
		PC	REC TYPE	REC SIZE	PART #	NO DRILL	FOOTNOTES	OPTIONAL DRAWBAR	WC (LBS.)	WD (LBS.)	IN
BUICK (Continued)											
Rendezvous	02-07	34	SQ2	1-1/4	36425		HM	36071	300/3,500		40
		33	SQ3	2	75138	0			350/3,500		55
		28	SQ3	2	75430		HM		350/3,500		40
Terraza	05-07	27	SQ2	1-1/4	36361		AL,GP,JR	36061	300/3,500		40
		22	SQ3	2	75278		AL,GP,JR		350/3,500	500/5,000	40
Verano Except Turbo or w/Dual Exhaust	12-16	18	SQ1	1-1/4	24882	0	AW,GP,JR,KH,QW	3593	200/2,000		40
CADILLAC											
ATS Except ATS-V	13-17	29	SQ1	1-1/4	24924	0	GP	3594	200/2,000		30
CTS	03-07	33	SQ1	1-1/4	24767		JR,TA,HM	3594	200/2,000		45
CTS 4 Dr. Sedan	08-13	33	SQ1	1-1/4	24767		JR,TA,HM	3594	200/2,000		45
CTS 4 Dr. Sedan	14-15	30	SQ1	1-1/4	24927		GP,JR,KH,TA	3593	200/2,000		60
CTS 4 Dr. Sedan, Except CTS-V	16-17	30	SQ1	1-1/4	24927		GP,JR,KH,TA	3593	200/2,000		60
CTS V	04-07	33	SQ1	1-1/4	24767		JR,TA,HM	3594	200/2,000		45
CTS V 4 Dr. Sedan	09-13	33	SQ1	1-1/4	24767		JR,TA,HM	3594	200/2,000		45
DeVille	97-99	50	SQ2	1-1/4	36267		JR,GP	36063	300/3,500		20
DeVille	00-05	33	SQ2	1-1/4	36287	0	GP	36071	300/3,500		20
DTS	06-11	33	SQ2	1-1/4	36287	0	GP	36071	300/3,500		20
Escalade	99-00	37	SQ3	2	75037		HM		500/5,000	750/7,500	30
		41	SQ4	2	41511		HM		600/6,000	1,000/10,000	30
Escalade	02-02	29	RT4	2	75725	0	CN,HM		900/6,000	1,000/10,000	15
Escalade w/Factory 7-Way	02-11										
Escalade	03-06	35	SQ4	2	75172	0	CN		600/6,000	750/7,500	30
Escalade	07-16										
Escalade ESV	03-06	35	SQ4	2	75172	0	CN		600/6,000	750/7,500	30
Escalade ESV w/Factory 7-Way	03-11										
Escalade ESV w/Factory 7-Way	07-11										
Escalade EXT	02-02	29	RT4	2	75725	0	CN,HM		900/6,000	1,000/10,000	15
Escalade EXT w/Factory 7-Way	02-11										
Escalade EXT	03-06	35	SQ4	2	75172	0	CN		600/6,000	750/7,500	30
Seville	98-04	40	SQ2	1-1/4	36243	0	EP,GP,JR	36051	300/3,500		35
SRX Except w/Sport Package Fascia	04-09	58	RT3	2	75174	0	JR,KH		350/3,500	500/5,000	60
SRX	10-16	28	RT3	2	75682	0			400/4,000	500/5,000	15
STS	05-11	33	SQ1	1-1/4	24767		JR,TA,HM	3594	200/2,000		45
XT5 Except Platinum	17-17	23	SQ3	2	76022	0	GP		675/4,500	675/4,500	20
XTS	13-14	42	SQ2	1-1/4	36538		HM	36061	300/3,500		35
XTS	13-16	46	SQ2	1-1/4	36762		HM	36061	300/3,500		30
CHEVROLET											
Astro Extended Body	90-05	33	SQ2	1-1/4	36197	0	CS,HM	36051	300/3,500		30
		34	SQ2	1-1/4	36198	0	CS,GP		36053	300/3,500	
		33	SQ3	2	75122	0	CS,GP			300/3,500	600/6,000
		50	SQ3	2	37136		AF		500/5,000	600/6,000	65
Avalanche 1500	02-06	29	RT4	2	75725	0	CN,HM		900/6,000	1,000/10,000	15
Avalanche 1500 w/Factory 7-Way	02-11										
Avalanche 1500 w/Factory 7-Way	07-11										
Avalanche 2500	02-06	29	RT4	2	75725	0	CN,HM		900/6,000	1,000/10,000	15

- AF** Hitch is ONLY rated for Weight Carrying at 3500 lbs. GTW / 350 lbs. TW and DO NOT use Weight Distribution Spring Bars for this Specific Vehicle. Except for long bed pickups.
- AL** Additional installation time required for vehicles equipped with load leveling compressor.
- AW** Will not fit Turbo models.
- CN** Requires OEM factory bumper for hitch installation.
- GS** Will fit with full-size spare tire stowed under vehicle.
- EP** Fascia trimming may be required.

- GP** Hitch cross-tube concealed behind bumper.
- HM** Hitch cross-tube is visible beneath bumper.
- JR** Exhaust must be temporarily lowered for installation.
- KH** Minor heat shield modification may be required.
- QW** Will not fit vehicles with dual exhaust.
- TA** Trunk access required for hitch installation.

RECEIVER HITCH APPLICATION GUIDE



CHEVROLET

T-ONE						TOW HARNESS						4-FLAT WIRING				REQ. 4 FLAT WIRING			BRAKE CONTROL HARNESS	IN	
PC	T-ONE	FN	IN	AMP	CP	PC	TOW HARN	FN	IN	AMP	CP	TYPE	ELEC	POS	CHOICE 1	CHOICE 2	6-WAY ADAPTER	7-WAY ADAPTER			7-WAY HARDWIRE
BUICK (Continued)																					
E10	118383	BN	20	7.5									A	SUV1,2	119180	20252	20320	20321	20224		
E10	118396	BN	15	7.5									A	SUV1,2	119180	20252	20320	20321	20224		
E17	118564	CH	45	2.1,5.6	X								B,E	PC3,4	119148	119180					
CADILLAC																					
E15	118580	CH	25	2.1,5.6	X								B,E	PC3,4	119148	119180					
E15	118440	CH	45	2.1,4.2	X								B,E	PC3,4	119148	119180					
E15	118466	CH	15	2.1,5.6	X								A,E	PC3,4	119148	119180					
E15	118645	CH	45	2.1,5.6	X								A,E	PC3,4	119148	119180					
E15	118645	CH	45	2.1,5.6	X								A,E	PC3,4	119148	119180					
E15	118440	CH	45	2.1,4.2	X								B,E	PC3,4	119148	119180					
													A,E	PC3,4	119148	119180					
													E	PC3,4	119180	119148					
													E	PC3,4	119180	119148					
E16	118535	CH	45	2.1,5.6	X								B,E	PC3,4	119148	119180					
E3	118319	BN	5	7.5									A	SUV7	119180	20252	20320	20321	20224		
						E8	118384	BN,RD	5	7.5		4-Flat	A	SUV6	119180	20252	20320	20321	20224	3025-P	5
							20119	RD	10			Both	H	SUV6	119180	20252					
							20047	RD	5			7-Way									
							118015	RD	10			7-Way									
						E8	118384	BN,RD	5	7.5		4-Flat	A	SUV6	119180	20252	20320	20321	20224	3015-P	5
						E8	118384	BN,RD	5	7.5		4-Flat	H	SUV6	119180	20252					
						E8	118384	BN,RD	5	7.5		4-Flat	A	SUV6	119180	20252	20320	20321	20224	3015-P	5
							20119	RD	10			Both	H	SUV6	119180	20252					
							20047	RD	5			7-Way									
							118015	RD	10			7-Way									
						E8	118384	BN,RD	5	7.5		4-Flat	H	SUV6	119180	20252					
						E8	118384	BN,RD	5	7.5		4-Flat	A	SUV6	119180	20252	20320	20321	20224	3025-P	5
							20119	RD	10			Both	H	SUV6	119180	20252					
							20047	RD	5			7-Way									
							118015	RD	10			7-Way									
						E8	118384	BN,RD	5	7.5		4-Flat	A	SUV6	119180	20252	20320	20321	20224	3015-P	5
													B,E	PC3,4	119148	119180					
													E	SUV3,4	119180	119148	20320	20321	20224		
						E3	118259	BN	5	7.5		4-Flat	E	SUV3,4	119180	119148	20320	20321	20224		
													E	PC3,4	119180	119148					
E3	118720	BN	10			E9	118276	BN	10				A	SUV6	119180	20252					
													A,E	PC3,4	119148	119180					
													A,E	PC3,4	119148	119180					
CHEVROLET																					
													A	SUV4	119180	20252	20320	20321	20224		
						E8	118384	BN,RD	5	7.5		4-Flat	A	SUV6	119180	20252	20320	20321	20224	3015-P	5
							20119	RD	10			Both	H	SUV6	119180	20252					
							20047	RD	5			7-Way									
							118015	RD	10			7-Way									
						E8	118384	BN,RD	5	7.5		4-Flat	H	SUV6	119180	20252					
						E8	118384	BN,RD	5	7.5		4-Flat	A	SUV6	119180	20252	20320	20321	20224	3015-P	5

A 2 wire system.
B 3 wire system. Converter required.
BN Exterior mounted plug on some or all models. May require an aftermarket electrical mounting box or bracket. (Sold separately)
CH T-One is equipped with circuit protected ModuLite® module.

E ModuLite® required.
H 3 wire system with OEM standard 2 wire harness.
RD For vehicles equipped with factory tow package may require additional components or may be used as a replacement harness.

RT3 Round Tube Class III 2"
RT4 Round Tube Class IV 2"
SQ1 Square Tube Class I
SQ2 Square Tube Class II
SQ3 Square Tube Class III
SQ4 Square Tube Class IV

RECEIVER HITCHES

RECEIVER HITCH APPLICATION GUIDE

MODEL / STYLE	YEAR	TRAILER HITCHES									
		PC	REC TYPE	REC SIZE	PART #	NO DRILL	FOOTNOTES	OPTIONAL DRAWBAR	WC (LBS.)	WD (LBS.)	IN
CHEVROLET (Continued)											
Avalanche 2500 w/Factory 7-Way	02-11										
Avalanche 2500 w/Factory 7-Way	07-11										
Aveo 5 Dr. Hatchback	04-11	20	SQ1	1-1/4	24741		GP	3593	200/2,000		30
Aveo 4 Dr. Sedan	06-06	23	SQ1	1-1/4	24810	0	HM,TA	3593	200/2,000		20
Aveo 4 Dr. Sedan	07-11	23	SQ1	1-1/4	24810	0	HM,TA	3593	200/2,000		20
Blazer Downsize	95-98	32	SQ2	1-1/4	36244	0	FP,GP,KK	36051	300/3,500		15
		21	RT3	2	75079	0	FP,KK,SD		400/4,000	600/6,000	15
Blazer Downsize	99-01	32	SQ2	1-1/4	36244	0	FP,GP,KK	36051	300/3,500		15
		21	RT3	2	75079	0	FP,KK,SD		400/4,000	600/6,000	15
Blazer Downsize, w/Factory 7-Way	99-01										
Blazer Downsize	02-05	32	SQ2	1-1/4	36244	0	FP,GP,KK	36051	300/3,500		15
		21	RT3	2	75079	0	FP,KK,SD		400/4,000	600/6,000	15
Blazer Trailblazer	99-01	32	SQ2	1-1/4	36244	0	FP,GP,KK	36051	300/3,500		15
		21	RT3	2	75079	0	FP,KK,SD		400/4,000	600/6,000	15
Blazer Trailblazer w/Factory 7-Way	99-01										
C1500	88-99	49	RT3	2	37133				500/5,000	750/7,500	40
		35	SQ3	2	75033	0	HM,J		500/5,000	800/8,000	20
		25	SQ3	2	75099	0	GP		500/5,000	800/8,000	20
		30	SQ4	2	40050		HC		600/6,000	1,000/10,000	40
		44	SQ4	2	41524	0	GP		600/6,000	1,000/10,000	20
		38	SQ4	2	41525	0	HM,J		600/6,000	1,000/10,000	20
		54	RT4	2	37130				700/7,000	1,200/12,000	40
		45	SQ5	2	41901		@,DB,GP,SN		1,000/10,000	1,300/13,000	30
								1,200/12,000	1,700/14,000	30	
C1500 w/10" Deep Drop Bumper	88-99	53	SQ4	2	41528	0	FS,J		600/6,000	1,000/10,000	20
C1500 w/Aftermarket Roll Pan	88-99	38	SQ3	2	41522		CO,HK		500/5,000	550/5,500	40
C2500 Regular & Extended Cabs	88-99	49	RT3	2	37133				500/5,000	750/7,500	40
		35	SQ3	2	75033	0	HM,J		500/5,000	800/8,000	20
		25	SQ3	2	75099	0	GP		500/5,000	800/8,000	20
		30	SQ4	2	40050		HC		600/6,000	1,000/10,000	40
		44	SQ4	2	41524	0	GP		600/6,000	1,000/10,000	20
		38	SQ4	2	41525	0	HM,J		600/6,000	1,000/10,000	20
		54	RT4	2	37130				700/7,000	1,200/12,000	40
		45	SQ5	2	41901		@,DB,GP,SN		1,000/10,000	1,300/13,000	30
		59	SQ5	2-1/2	45506		#		1,200/12,000	1,700/14,000	45
C2500 Regular & Extended Cabs, w/10" Deep Drop Bumper	88-99	53	SQ4	2	41528	0	FS,J		600/6,000	1,000/10,000	20
C2500 w/Aftermarket Roll Pan	88-99	38	SQ3	2	41522		CO,HK		500/5,000	550/5,500	40
C2500 Crew Cab	92-00	49	RT3	2	37133	0			500/5,000	750/7,500	40
		35	SQ3	2	75033	0	HM,J		500/5,000	800/8,000	20
		25	SQ3	2	75099	0	GP		500/5,000	800/8,000	20
		30	SQ4	2	40050		FS		600/6,000	1,000/10,000	40
		44	SQ4	2	41524	0	GP		600/6,000	1,000/10,000	20
		38	SQ4	2	41525	0	HM,J		600/6,000	1,000/10,000	20
		54	RT4	2	37130				700/7,000	1,200/12,000	40
		45	SQ5	2	41901		@,DB,GP,SN		1,000/10,000	1,300/13,000	30
		59	SQ5	2-1/2	45506		#		1,200/12,000	1,700/14,000	45
C2500 Crew Cab w/10" Deep Drop Bumper	92-00	53	SQ4	2	41528	0	FS,J		600/6,000	1,000/10,000	20

- # Titan hitches require use of a 2-1/2" shank Titan ball mount.
- @ Ultra Frame ball mount must be used to achieve maximum weight carrying rating.
- CO Will not fit 8 ft. 2500/3500 Series with heavy-duty suspension or four door Crew Cab.
- DB Will not fit 6 ft. bed pickups.
- FP Spare tire repositioning and/or modification of spare tire carrier may be required.
- FS Includes 2 & 4 WD models with heavy duty suspension.
- GP Hitch cross-tube concealed behind bumper.
- HC Will not fit with mini or full size tire stowed under vehicle.
- HK Under vehicle spare tire stowage may be retained with installation of an aftermarket spare tire repositioner. Cutting of rollpan in license plate area required for receiver tube access. Does not fit with bumper.
- HM Hitch cross-tube is visible beneath bumper.
- J Under vehicle spare tire stowage is retained.
- KK When installing on a vehicle originally equipped with an OEM hitch, OEM bumper brackets must be purchased and installed prior to new hitch installation.
- SD Hitches produced before 07/21/06 are rated at 350/3500 WC.
- SN Hitches produced before 04/28/08 are rated at 1000/10000 WC & 1200/12000 WD.
- TA Trunk access required for hitch installation.

RECEIVER HITCH APPLICATION GUIDE

T-ONE						TOW HARNESS						4-FLAT WIRING				REQ. 4 FLAT WIRING		BRAKE CONTROL HARNESS	IN	
PC	T-ONE	FN	IN	AMP	CP	PC	TOW HARN	FN	IN	AMP	CP	TYPE	ELEC	POS	CHOICE 1	CHOICE 2	6-WAY ADAPTER			7-WAY ADAPTER
CHEVROLET (Continued)																				
							20119 20047 118015	RD RD RD	10 5 10			Both 7-Way 7-Way	H	SUV6	119180	20252				
						E8	118384	BN,RD	5	7.5		4-Flat	H	SUV6	119180	20252				
E13	118485	CG	15	2.1,7.5	X								B	PC3,4	119130	119178				
E13	118485	CG	15	2.1,7.5	X								B	PC3,4	119130	119178				
E12	118514		25	2.1,5	X								B	PC3,4	119130	119178				
													A	SUV7	119180	20252	20320	20321	20224	
						E8	118384	BN,RD	5	7.5		4-Flat	A	SUV7	119180	20252	20320	20321	20224	
							20119 118015 20047	RD RD RD	10 10 5			Both 7-Way 7-Way	A	SUV7	119180	20252				
													A	SUV7	119180	20252	20320	20321	20224	
						E8	118384	BN,RD	5	7.5		4-Flat	A	SUV7	119180	20252	20320	20321	20224	
							20119 118015 20047	RD RD RD	10 10 5			Both 7-Way 7-Way	A	SUV7	119180	20252				
E3	118315	BN	5	7.5									A	PU3	119180	20252	20320	20321	20224	
E3	118315	BN	5	7.5									A	PU3	119180	20252	20320	20321	20224	
E3	118315	BN	5	7.5									A	PU3	119180	20252	20320	20321	20224	
E3	118315	BN	5	7.5									A	PU3	119180	20252	20320	20321	20224	
E3	118315	BN	5	7.5									A	PU3	119180	20252	20320	20321	20224	
E3	118315	BN	5	7.5									A	PU3	119180	20252	20320	20321	20224	
E3	118315	BN	5	7.5									A	PU3	119180	20252	20320	20321	20224	

A 2 wire system.
B 3 wire system. Converter required.
BN Exterior mounted plug on some or all models. May require an aftermarket electrical mounting box or bracket. (Sold separately)
CG T-One incorporates circuit protected taillight converter.
H 3 wire system with OEM standard 2 wire harness.
RD For vehicles equipped with factory tow package may require additional components or may be used as a replacement harness.

RT3 Round Tube Class III 2"
RT4 Round Tube Class IV 2"
SQ1 Square Tube Class I
SQ2 Square Tube Class II
SQ3 Square Tube Class III
SQ4 Square Tube Class IV
SQ5 Square Tube Class V

RECEIVER HITCH APPLICATION GUIDE

MODEL / STYLE	YEAR	TRAILER HITCHES									
		PC	REC TYPE	REC SIZE	PART #	NO DRILL	FOOTNOTES	OPTIONAL DRAWBAR	WC (LBS.)	WD (LBS.)	IN
CHEVROLET (Continued)											
C3500 Regular & Extended Cabs	88-00	49	RT3	2	37133				500/5,000	750/7,500	40
		35	SQ3	2	75033	0	HM,J		500/5,000	800/8,000	20
		25	SQ3	2	75099	0	GP		500/5,000	800/8,000	20
		30	SQ4	2	40050		HC		600/6,000	1,000/10,000	40
		44	SQ4	2	41524	0	GP		600/6,000	1,000/10,000	20
		38	SQ4	2	41525	0	HM,J		600/6,000	1,000/10,000	20
		54	RT4	2	37130				700/7,000	1,200/12,000	40
		45	SQ5	2	41901		@,DB,GP,SN		1,000/10,000	1,300/13,000	30
		59	SQ5	2-1/2	45506	#		1,200/12,000	1,700/14,000	45	
C3500 Regular & Extended Cabs, w/10" Deep Drop Bumper	88-00	53	SQ4	2	41528	0	FS,J		600/6,000	1,000/10,000	20
C3500 w/Aftermarket Roll Pan	88-00	38	SQ3	2	41522		CO,HK		500/5,000	550/5,500	40
C3500 Crew Cab	92-00	49	RT3	2	37133	0			500/5,000	750/7,500	40
		35	SQ3	2	75033	0	HM,J		500/5,000	800/8,000	20
		25	SQ3	2	75099	0	GP		500/5,000	800/8,000	20
		44	SQ4	2	41524	0	GP		600/6,000	1,000/10,000	20
		38	SQ4	2	41525	0	HM,J		600/6,000	1,000/10,000	20
		54	RT4	2	37130				700/7,000	1,200/12,000	40
		45	SQ5	2	41901		@,DB,GP,SN		1,000/10,000	1,300/13,000	30
		59	SQ5	2-1/2	45506	#			1,200/12,000	1,700/14,000	45
C3500 Crew Cab w/10" Deep Drop Bumper	92-00	53	SQ4	2	41528	0	FS,J		600/6,000	1,000/10,000	20
Camaro Except w/Dual Exhaust Pipes On Drivers Side	97-02	45	SQ1	1-1/4	24586†		†,JR	3592	200/2,000		40
Camaro Except Convertible & w/Dealer Installed Ground Effects	10-11	31	SQ1	1-1/4	24850	0	GP	3594	200/2,000		15
Camaro Except Convertible & w/Dealer Installed Ground Effects	12-15	31	SQ1	1-1/4	24850	0	GP	3594	200/2,000		15
Camaro	16-17	23	SQ1	1-1/4	24938	0	GP	3593	200/2,000		50
Captiva Sport	12-12	30	SQ3	2	75556	0	GP		400/4,000	400/4,000	15
Captiva Sport	13-15	30	SQ3	2	75556	0	GP		400/4,000	400/4,000	15
Cavalier Except Z-24	95-99	31	SQ1	1-1/4	24733		GP,JR	3592	200/2,000		40
Cavalier	00-01	31	SQ1	1-1/4	24733		GP,JR	3592	200/2,000		40
Cavalier Except Z-24	02-02	31	SQ1	1-1/4	24733		GP,JR	3592	200/2,000		40
Cavalier Except LS Sport	03-05	31	SQ1	1-1/4	24733		GP,JR	3592	200/2,000		40
Cavalier LS Sport	03-05	39	SQ1	1-1/4	24613		JR,KH,GP	3592	200/2,000		40
Cavalier Z-24	95-99	39	SQ1	1-1/4	24613		JR,KH,GP	3592	200/2,000		40
Cavalier Z-24	02-02	39	SQ1	1-1/4	24613		JR,KH,GP	3592	200/2,000		40
Cavalier Z-24 (Canada Only)	03-05	39	SQ1	1-1/4	24613		JR,KH,GP	3592	200/2,000		40
City Express	15-16	31	RT3	2	75898	0	HM,JR,X		525/3,500		30
Cobalt 2 Dr., Except SS	05-10	20	SQ1	1-1/4	24745		JR,HM	3593	200/2,000		40
Cobalt 4 Dr., Except SS	05-10	20	SQ1	1-1/4	24745		JR,HM	3593	200/2,000		40
Cobalt Sport 2 Dr.	08-08	30	SQ1	1-1/4	24756		HM,JR	3594	200/2,000		25
Cobalt Sport 4 Dr.	08-08	30	SQ1	1-1/4	24756		HM,JR	3594	200/2,000		25
Cobalt SS 2 Dr.	05-10	30	SQ1	1-1/4	24756		HM,JR	3594	200/2,000		25
Cobalt SS 4 Dr.	05-10	30	SQ1	1-1/4	24756		HM,JR	3594	200/2,000		25
Colorado	04-12	23	SQ4	2	75607	0	CP,GP		600/6,000	750/7,500	25
Colorado w/Factory 7-Way	04-12										
Colorado	15-16	34	RT4	2	75948	0	HM,AA,V,SO,TZ		800/6,000	800/8,000	35
		30	SQ4	2	76004	0	HM,AA,V,SO,TZ		800/8,000	1,000/10,000	35
Cruze	11-15	18	SQ1	1-1/4	24882	0	GP	3593	200/2,000		15
Cruze (New Body Style)	16-16	18	SQ1	1-1/4	24943	0	GP,X,DU,TA	3593	200/2,000		80
Cruze Limited Only (Old Body Style)	16-16	18	SQ1	1-1/4	24882	0	GP	3593	200/2,000		15
Cruze Hatchback	17-17	18	SQ1	1-1/4	24951	0	GP,X,DU	3594	200/2,000		60

- # Titan hitches require use of a 2-1/2" shank Titan ball mount.
- @ Ultra Frame ball mount must be used to achieve maximum weight carrying rating.
- † Available while supply lasts.
- AA Requires temporary removal of bumper during installation.
- CO Will not fit 8 ft. 2500/3500 Series with heavy-duty suspension or four door Crew Cab.
- CP Fits all models without factory installed receiver.
- DB Will not fit 6 ft. bed pickups.
- DU Fascia removal required.
- FS Includes 2 & 4 WD models with heavy duty suspension.
- GP Hitch cross-tube concealed behind bumper.
- HC Will not fit with mini or full size tire stowed under vehicle.
- HK Under vehicle spare tire stowage may be retained with installation of an aftermarket spare tire repositioner. Cutting of rollpan in license plate area required for receiver tube access. Does not fit with bumper.
- HM Hitch cross-tube is visible beneath bumper.
- J Under vehicle spare tire stowage is retained.
- JR Exhaust must be temporarily lowered for installation.
- KH Minor heat shield modification may be required.
- SN Hitches produced before 04/28/08 are rated at 1000/10000 WC & 1200/12000 WD.
- SO With this hitch installed the step bumper is no longer able to be used as a towing point.
- TA Trunk access required for hitch installation.
- TZ Requires replacement of the impact structure with hitch.
- V For vehicles with factory installed step bumpers only.

RECEIVER HITCH APPLICATION GUIDE



CHEVROLET

T-ONE						TOW HARNESS						4-FLAT WIRING				REQ. 4 FLAT WIRING		7-WAY HARDWIRE	BRAKE CONTROL HARNESS	IN
PC	T-ONE	FN	IN	AMP	CP	PC	TOW HARN	FN	IN	AMP	CP	TYPE	ELEC	POS	CHOICE 1	CHOICE 2	6-WAY ADAPTER			
CHEVROLET (Continued)																				
E3	118315	BN	5	7.5									A	PU3	119180	20252	20320	20321	20224	
E3	118315	BN	5	7.5									A	PU3	119180	20252	20320	20321	20224	
E3	118315	BN	5	7.5									A	PU3	119180	20252	20320	20321	20224	
E3	118315	BN	5	7.5									A	PU3	119180	20252	20320	20321	20224	
E17	118486	CH	15	2.1,5.6	X								A,E	PC1,2	119148	119180				
E16	118556	CH	25	2.1,5.6	X								A,E	PC1,2	119148	119180				
E17	118690	CH	45	4.2,7.5	X								A,E	PC1,2	119148	119180				
E19	118443	CH	45	2.1,4.2	X								B,E	SUV3,4	119148	119180	20320	20321	20224	
													B,E	SUV3,4	119148	119180	20320	20321	20224	
													A	PC3,4	119180	20252				
													A	PC3,4	119180	20252				
													A	PC3,4	119180	20252				
													A	PC3,4	119180	20252				
													A	PC3,4	119180	20252				
													A	PC3,4	119180	20252				
													A	PC3,4	119180	20252				
E17	118597	CH	45	4.2,7.5	X								B,E	SUV3,4	119148	119180	20320	20321		
E5	118407	BN	15	7.5									A	PC1,2	119180	20252				
E8	118398	BN	10	7.5									A	PC1,2	119180	20252				
E5	118407	BN	15	7.5									A	PC1,2	119180	20252				
E8	118398	BN	10	7.5									A	PC1,2	119180	20252				
E5	118407	BN	15	7.5									A	PC1,2	119180	20252				
E8	118398	BN	10	7.5									A	PC1,2	119180	20252				
E10	118301	BN,CG	10	2.1,5	X	E8	118384	BN,RD	5	7.5		4-Flat	B	PU3	119130	119178	20320	20321	20224	
							20119	RD	10			Both	H	PU3	119180	20252				
							20047	RD	5			7-Way								
							118015	RD	10			7-Way								
													A	PU3	119180	20252	20320	20321	20224	
E19	118508	CH	45	2.1,5.6	X								B,E	PC3,4	119148	119180				
E14	118696	CH	45		X								A,E	PC3,4	119148	119180				
E19	118508	CH	45	2.1,5.6	X								B,E	PC3,4	119148	119180				

A 2 wire system.
B 3 wire system. Converter required.
BN Exterior mounted plug on some or all models. May require an aftermarket electrical mounting box or bracket. (Sold separately)
CG T-One incorporates circuit protected taillight converter.

CH T-One is equipped with circuit protected ModuLite® module.
E ModuLite® required.
H 3 wire system with OEM standard 2 wire harness.
RD For vehicles equipped with factory tow package may require additional components or may be used as a replacement harness.

RT3 Round Tube Class III 2"
RT4 Round Tube Class IV 2"
SQ1 Square Tube Class I
SQ3 Square Tube Class III
SQ4 Square Tube Class IV
SQ5 Square Tube Class V

RECEIVER HITCHES

RECEIVER HITCH APPLICATION GUIDE

MODEL / STYLE	YEAR	TRAILER HITCHES										
		PC	REC TYPE	REC SIZE	PART #	NO DRILL	FOOTNOTES	OPTIONAL DRAWBAR	WC (LBS.)	WD (LBS.)	IN	
CHEVROLET (Continued)												
Equinox	05-06	18	SQ2	1-1/4	36408	0	HM	36051	300/3,500	675/4,500	25	
		15	RT3	2	76028	0	HM		675/4,500		30	
Equinox	07-09	18	SQ2	1-1/4	36408	0	HM	36051	300/3,500	675/4,500	25	
		15	RT3	2	76028	0	HM		675/4,500		30	
Equinox	10-17	18	SQ2	1-1/4	36408	0	HM	36051	300/3,500	675/4,500	25	
		15	RT3	2	76028	0	HM		675/4,500		30	
Express 1500	96-99	34	SQ2	1-1/4	36206	0	HM	36053	300/3,500	600/6,000	15	
		50	SQ3	2	37136	0	HM		500/5,000		30	
		22	SQ3	2	75189	0	HM		500/5,000		750/7,500	15
		33	SQ4	2	41521	0	HM		600/6,000		1,000/10,000	15
		42	SQ5	2	41946	0	@,HM		1,500/10,000		1,300/13,000	35
Express 1500	00-02	34	SQ2	1-1/4	36206	0	HM	36053	300/3,500	600/6,000	15	
		50	SQ3	2	37136	0	HM		500/5,000		30	
		22	SQ3	2	75189	0	HM		500/5,000		750/7,500	15
		33	SQ4	2	41521	0	HM		600/6,000		1,000/10,000	15
		42	SQ5	2	41946	0	@,HM		1,500/10,000		1,300/13,000	35
Express 1500	03-03	34	SQ2	1-1/4	36206	0	HM	36053	300/3,500	600/6,000	15	
		50	SQ3	2	37136	0	HM		500/5,000		30	
		22	SQ3	2	75189	0	HM		500/5,000		750/7,500	15
		33	SQ4	2	41521	0	HM		600/6,000		1,000/10,000	15
		42	SQ5	2	41946	0	@,HM		1,500/10,000		1,300/13,000	35
Express 1500	04-14	34	SQ2	1-1/4	36206	0	HM	36053	300/3,500	600/6,000	15	
		50	SQ3	2	37136	0	HM		500/5,000		30	
		22	SQ3	2	75189	0	HM		500/5,000		750/7,500	15
		33	SQ4	2	41521	0	HM		600/6,000		1,000/10,000	15
		42	SQ5	2	41946	0	@,HM		1,500/10,000		1,300/13,000	35
Express 2500	96-99	34	SQ2	1-1/4	36206	0	HM	36053	300/3,500	600/6,000	15	
		50	SQ3	2	37136	0	HM		500/5,000		30	
		22	SQ3	2	75189	0	HM		500/5,000		750/7,500	15
		33	SQ4	2	41521	0	HM		600/6,000		1,000/10,000	15
		42	SQ5	2	41946	0	@,HM		1,500/10,000		1,300/13,000	35
		52	SQ5	2-1/2	45507	0	#,HM		1,200/12,000		1,700/14,000	45
Express 2500	00-02	34	SQ2	1-1/4	36206	0	HM	36053	300/3,500	600/6,000	15	
		50	SQ3	2	37136	0	HM		500/5,000		30	
		22	SQ3	2	75189	0	HM		500/5,000		750/7,500	15
		33	SQ4	2	41521	0	HM		600/6,000		1,000/10,000	15
		42	SQ5	2	41946	0	@,HM		1,500/10,000		1,300/13,000	35
		52	SQ5	2-1/2	45507	0	#,HM		1,200/12,000		1,700/14,000	45
Express 2500	03-03	34	SQ2	1-1/4	36206	0	HM	36053	300/3,500	600/6,000	15	
		50	SQ3	2	37136	0	HM		500/5,000		30	
Express 2500	03-03	22	SQ3	2	75189	0	HM	36053	500/5,000	750/7,500	15	
		33	SQ4	2	41521	0	HM		600/6,000		1,000/10,000	15
Express 2500	03-03	42	SQ5	2	41946	0	@,HM	36053	1,500/10,000	1,300/13,000	35	
		52	SQ5	2-1/2	45507	0	#,HM		1,200/12,000		1,700/14,000	45
Express 2500	04-16	50	SQ3	2	37136	0	HM	36053	500/5,000	600/6,000	30	
Express 2500	04-17	34	SQ2	1-1/4	36206	0	HM	36053	300/3,500	600/6,000	15	
		22	SQ3	2	75189	0	HM		500/5,000		750/7,500	15
		33	SQ4	2	41521	0	HM		600/6,000		1,000/10,000	15
		42	SQ5	2	41946	0	@,HM		1,500/10,000		1,300/13,000	35
		52	SQ5	2-1/2	45507	0	#,HM		1,200/12,000		1,700/14,000	45

Titan hitches require use of a 2-1/2" shank Titan ball mount.
 @ Ultra Frame ball mount must be used to achieve maximum weight carrying rating.

HM Hitch cross-tube is visible beneath bumper.

RECEIVER HITCH APPLICATION GUIDE



CHEVROLET

T-ONE						TOW HARNESS						4-FLAT WIRING				REQ. 4 FLAT WIRING		7-WAY HARDWIRE	BRAKE CONTROL HARNESS	IN	
PC	T-ONE	FN	IN	AMP	CP	PC	TOW HARN	FN	IN	AMP	CP	TYPE	ELEC	POS	CHOICE 1	CHOICE 2	6-WAY ADAPTER				7-WAY ADAPTER
CHEVROLET (Continued)																					
E8	118391	CG	10	2.1,5	X								B	SUV3	119130	119178	20320	20321	20224		
E7	118432	CE	10	7.5									B	SUV1,2	119130	119178	20320	20321	20224		
E16	118494	CH	45	2.1,5,6	X	E1	118264	RD	15	7.5		4-Flat	N	SUV1,2		119251	20320	20321			
E8	118335	HG	10	2.1,5		E1	118240	RD	5	7.5		4-Flat	B	SUV3,4	119130	119178	20320	20321	20224		
E8	118377	HG	10	2.1,5		E1	118240	RD	5	7.5		4-Flat	B	SUV3,4	119130	119178	20320	20321	20224		
E5	118392		20	7.5		E1	118240	RD	5	7.5		4-Flat	A	SUV3,4	119180	20252	20320	20321	20224		
E5	118392		20	7.5									A	SUV3,4	119180	20252	20320	20321	20224		
E8	118335	HG	10	2.1,5		E1	118240	RD	5	7.5		4-Flat	B	SUV3,4	119130	119178	20320	20321	20224		
E8	118377	HG	10	2.1,5		E1	118240	RD	5	7.5		4-Flat	B	SUV3,4	119130	119178	20320	20321	20224		
E5	118392		20	7.5		E1	118240	RD	5	7.5		4-Flat	A	SUV3,4	119180	20252	20320	20321	20224		
E5	118392		20	7.5									A	SUV3,4	119180	20252	20320	20321	20224		
E5	118392		20	7.5									A	SUV3,4	119180	20252	20320	20321	20224		

- A** 2 wire system.
- B** 3 wire system. Converter required.
- CE** T-One includes fuse(s) & relay(s). Converter not required. Standard 2 wire system at factory tow plug.
- CG** T-One incorporates circuit protected taillight converter.

- CH** T-One is equipped with circuit protected Modulite® module.
- HG** T-One incorporates taillight converter.
- N** DO NOT cut or splice vehicle wiring. Only use approved T-One or see auto dealer for trailer tow wiring kit.
- RD** For vehicles equipped with factory tow package may require additional components or may be used as a replacement harness.

- RT3** Round Tube Class III 2"
- SQ2** Square Tube Class II
- SQ3** Square Tube Class III
- SQ4** Square Tube Class IV
- SQ5** Square Tube Class V

RECEIVER HITCHES

RECEIVER HITCH APPLICATION GUIDE

MODEL / STYLE	YEAR	TRAILER HITCHES									
		PC	REC TYPE	REC SIZE	PART #	NO DRILL	FOOTNOTES	OPTIONAL DRAWBAR	WC (LBS.)	WD (LBS.)	IN
CHEVROLET (Continued)											
Express 3500	96-99	34	SQ2	1-1/4	36206	0	HM	36053	300/3,500		15
		50	SQ3	2	37136	0	HM		500/5,000	600/6,000	30
		22	SQ3	2	75189	0	HM		500/5,000	750/7,500	15
		33	SQ4	2	41521	0	HM		600/6,000	1,000/10,000	15
		42	SQ5	2	41946	0	@,HM		1,500/10,000	1,300/13,000	35
		52	SQ5	2-1/2	45507	0	#,HM		1,200/12,000	1,700/14,000	45
Express 3500	00-02	34	SQ2	1-1/4	36206	0	HM	36053	300/3,500		15
		50	SQ3	2	37136	0	HM		500/5,000	600/6,000	30
		22	SQ3	2	75189	0	HM		500/5,000	750/7,500	15
		33	SQ4	2	41521	0	HM		600/6,000	1,000/10,000	15
		42	SQ5	2	41946	0	@,HM		1,500/10,000	1,300/13,000	35
		52	SQ5	2-1/2	45507	0	#,HM		1,200/12,000	1,700/14,000	45
Express 3500	03-03	34	SQ2	1-1/4	36206	0	HM	36053	300/3,500		15
		50	SQ3	2	37136	0	HM		500/5,000	600/6,000	30
		22	SQ3	2	75189	0	HM		500/5,000	750/7,500	15
		33	SQ4	2	41521	0	HM		600/6,000	1,000/10,000	15
		42	SQ5	2	41946	0	@,HM		1,500/10,000	1,300/13,000	35
		52	SQ5	2-1/2	45507	0	#,HM		1,200/12,000	1,700/14,000	45
Express 3500	04-16	50	SQ3	2	37136		HM		500/5,000	600/6,000	30
Express 3500	04-17	34	SQ2	1-1/4	36206	0	HM	36053	300/3,500		15
		22	SQ3	2	75189	0	HM		500/5,000	750/7,500	15
		33	SQ4	2	41521	0	HM		600/6,000	1,000/10,000	15
		42	SQ5	2	41946	0	@,HM		1,500/10,000	1,300/13,000	35
		52	SQ5	2-1/2	45507	0	#,HM		1,200/12,000	1,700/14,000	45
HHR	06-11	30	SQ1	1-1/4	24756		HM,JR	3594	200/2,000		25
HHR SS	08-10	30	SQ1	1-1/4	24756		EP,HM,JR	3594	200/2,000		35
Impala	00-05	25	SQ1	1-1/4	24681		GP	3590	200/2,000		20
		35	SQ2	1-1/4	36407	0	GP,JR	36061	300/3,500		30
Impala	06-13	35	SQ2	1-1/4	36407	0	GP,JR	36061	300/3,500		30
Impala Eco, Except Impala Limited	14-14	48	SQ2	1-1/4	36543	0	HM,X	36061	300/3,500		30
Impala Except Impala Limited	14-14	42	SQ2	1-1/4	36538		HM,FE	36061	300/3,500		35
Impala	15-17	42	SQ2	1-1/4	36538		HM,FE	36061	300/3,500		35
Impala LS Except Impala Limited	14-14	48	SQ2	1-1/4	36543	0	HM,X	36061	300/3,500		30
Impala LT Except Impala Limited	14-14	48	SQ2	1-1/4	36543	0	HM,X	36061	300/3,500		30
		46	SQ2	1-1/4	36762		HM,X	36061	300/3,500		40
Impala LTZ Except Impala Limited	14-14	48	SQ2	1-1/4	36543	0	HM,X	36061	300/3,500		30
		46	SQ2	1-1/4	36762		HM,X	36061	300/3,500		40
K1500	88-99	49	RT3	2	37133				500/5,000	750/7,500	40
		35	SQ3	2	75033	0	HM,J		500/5,000	800/8,000	20
		25	SQ3	2	75099	0	GP		500/5,000	800/8,000	20
		44	SQ4	2	41524	0	GP		600/6,000	1,000/10,000	20
		38	SQ4	2	41525	0	HM,J		600/6,000	1,000/10,000	20
		54	RT4	2	37130				700/7,000	1,200/12,000	40
		45	SQ5	2	41901		@,DB,GP,SN		1,000/10,000	1,300/13,000	30
K1500 w/10" Deep Drop Bumper	88-99	53	SQ4	2	41528	0	FS,J		600/6,000	1,000/10,000	20
K1500 w/Aftermarket Roll Pan	88-99	38	SQ3	2	41522		CO,HK		500/5,000	550/5,500	40

- # Titan hitches require use of a 2-1/2" shank Titan ball mount.
- @ Ultra Frame ball mount must be used to achieve maximum weight carrying rating.
- CO Will not fit 8 ft. 2500/3500 Series with heavy-duty suspension or four door Crew Cab.
- DB Will not fit 6 ft. bed pickups.
- EP Fascia trimming may be required.
- FE Fascia trimming may be required. Allow additional installation time.
- FS Includes 2 & 4 WD models with heavy duty suspension.
- GP Hitch crosstube concealed behind bumper.
- HK Under vehicle spare tire stowage may be retained with installation of an aftermarket spare tire repositioner. Cutting of rollpan in license plate area required for receiver tube access. Does not fit with bumper.
- HM Hitch crosstube is visible beneath bumper.
- J Under vehicle spare tire stowage is retained.
- JR Exhaust must be temporarily lowered for installation.
- SN Hitches produced before 04/28/08 are rated at 1000/10000 WC & 1200/12000 WD.
- X Minor fascia trimming required.

RECEIVER HITCH APPLICATION GUIDE

T-ONE						TOW HARNESS						4-FLAT WIRING				REQ. 4 FLAT WIRING		7-WAY HARDWIRE	BRAKE CONTROL HARNESS	IN
PC	T-ONE	FN	IN	AMP	CP	PC	TOW HARN	FN	IN	AMP	CP	TYPE	ELEC	POS	CHOICE 1	CHOICE 2	6-WAY ADAPTER			
CHEVROLET (Continued)																				
E8	118335	HG	10	2.1.5		E1	118240	RD	5	7.5		4-Flat	B	SUV3,4	119130	119178	20320	20321	20224	
E8	118377	HG	10	2.1.5		E1	118240	RD	5	7.5		4-Flat	B	SUV3,4	119130	119178	20320	20321	20224	
E5	118392		20	7.5		E1	118240	RD	5	7.5		4-Flat	A	SUV3,4	119180	20252	20320	20321	20224	
E5	118392		20	7.5									A	SUV3,4	119180	20252	20320	20321	20224	
E5	118392		20	7.5									A	SUV3,4	119180	20252	20320	20321	20224	
E5	118407	BN	15	7.5									A	SUV3,4	119180	20252	20320	20321		
E5	118407	BN	15	7.5									A	SUV3,4	119180	20252	20320	20321		
E5	118512		25	7.5									A	PC3,4	119180	20252				
E5	118417	BN	10	7.5									A	PC2	119180	20252				
E14	118590		45	2.1.5.6	X								A.E	PC3,4	119148	119180				
E14	118590		45	2.1.5.6	X								A.E	PC3,4	119148	119180				
													A.E	PC3,4	119148	119180				
E14	118590		45	2.1.5.6	X								A.E	PC3,4	119148	119180				
E14	118590		45	2.1.5.6	X								A.E	PC3,4	119148	119180				
E14	118590		45	2.1.5.6	X								A.E	PC3,4	119148	119180				
E3	118315	BN	5	7.5									A	PU3	119180	20252	20320	20321	20224	
E3	118315	BN	5	7.5									A	PU3	119180	20252	20320	20321	20224	
E3	118315	BN	5	7.5									A	PU3	119180	20252	20320	20321	20224	

A 2 wire system.
B 3 wire system. Converter required.
BN Exterior mounted plug on some or all models. May require an aftermarket electrical mounting box or bracket. (Sold separately)

E ModuLite® required.
HG T-One incorporates taillight converter.
RD For vehicles equipped with factory tow package may require additional components or may be used as a replacement harness.

RT3 Round Tube Class III 2"
RT4 Round Tube Class IV 2"
SQ1 Square Tube Class I
SQ2 Square Tube Class II
SQ3 Square Tube Class III
SQ4 Square Tube Class IV
SQ5 Square Tube Class V

RECEIVER HITCH APPLICATION GUIDE

MODEL / STYLE	YEAR	TRAILER HITCHES									
		PC	REC TYPE	REC SIZE	PART #	NO DRILL	FOOTNOTES	OPTIONAL DRAWBAR	WC (LBS.)	WD (LBS.)	IN
CHEVROLET (Continued)											
K2500 Regular & Extended Cabs	88-99	49	RT3	2	37133				500/5,000	750/7,500	40
		35	SQ3	2	75033	0	HM,J		500/5,000	800/8,000	20
		25	SQ3	2	75099	0	GP		500/5,000	800/8,000	20
		44	SQ4	2	41524	0	GP		600/6,000	1,000/10,000	20
		38	SQ4	2	41525	0	HM,J		600/6,000	1,000/10,000	20
		54	RT4	2	37130				700/7,000	1,200/12,000	40
		45	SQ5	2	41901		@,DB,GP,SN		1,000/10,000	1,300/13,000	30
		59	SQ5	2-1/2	45506		#	1,200/12,000	1,700/14,000	45	
K2500 Regular & Extended Cabs, w/10" Deep Drop Bumper	88-99	53	SQ4	2	41528	0	FS,J		600/6,000	1,000/10,000	20
K2500 w/Aftermarket Roll Pan	88-99	38	SQ3	2	41522		CO,HK		500/5,000	550/5,500	40
K2500 Crew Cab	92-00	49	RT3	2	37133	0			500/5,000	750/7,500	40
		35	SQ3	2	75033	0	HM,J		500/5,000	800/8,000	20
		25	SQ3	2	75099	0	GP		500/5,000	800/8,000	20
		44	SQ4	2	41524	0	GP		600/6,000	1,000/10,000	20
		38	SQ4	2	41525	0	HM,J		600/6,000	1,000/10,000	20
		54	RT4	2	37130				700/7,000	1,200/12,000	40
		45	SQ5	2	41901		@,DB,GP,SN		1,000/10,000	1,300/13,000	30
		59	SQ5	2-1/2	45506		#	1,200/12,000	1,700/14,000	45	
K2500 Crew Cab w/10" Deep Drop Bumper	92-00	53	SQ4	2	41528	0	FS,J		600/6,000	1,000/10,000	20
K3500 Regular & Extended Cabs	88-00	49	RT3	2	37133				500/5,000	750/7,500	40
		35	SQ3	2	75033	0	HM,J		500/5,000	800/8,000	20
		44	SQ4	2	41524	0	GP		600/6,000	1,000/10,000	20
		38	SQ4	2	41525	0	HM,J		600/6,000	1,000/10,000	20
		54	RT4	2	37130				700/7,000	1,200/12,000	40
		45	SQ5	2	41901		@,DB,GP,SN		1,000/10,000	1,300/13,000	30
				59	SQ5	2-1/2	45506		#	1,200/12,000	1,700/14,000
K3500 Regular & Extended Cabs, w/10" Deep Drop Bumper	88-00	53	SQ4	2	41528	0	FS,J		600/6,000	1,000/10,000	20
K3500 w/Aftermarket Roll Pan	88-00	38	SQ3	2	41522		CO,HK		500/5,000	550/5,500	40
K3500 Crew Cab	92-00	49	RT3	2	37133	0			500/5,000	750/7,500	40
		35	SQ3	2	75033	0	HM,J		500/5,000	800/8,000	20
		25	SQ3	2	75099	0	GP		500/5,000	800/8,000	20
		44	SQ4	2	41524	0	GP		600/6,000	1,000/10,000	20
		38	SQ4	2	41525	0	HM,J		600/6,000	1,000/10,000	20
		54	RT4	2	37130				700/7,000	1,200/12,000	40
		45	SQ5	2	41901		@,DB,GP,SN		1,000/10,000	1,300/13,000	30
		59	SQ5	2-1/2	45506		#	1,200/12,000	1,700/14,000	45	
K3500 Crew Cab w/10" Deep Drop Bumper	92-00	53	SQ4	2	41528	0	FS,J		600/6,000	1,000/10,000	20
Kodiak C4500 Cab & Chassis, w/34" Wide Frames	03-09	50	SQ5	2	41947		@		1,600/15,000	1,600/16,000	35
Kodiak C5500 Cab & Chassis, w/34" Wide Frames	03-09	50	SQ5	2	41947		@		1,600/15,000	1,600/16,000	35
Kodiak C6500 Cab & Chassis, w/34" Wide Frames	99-09	50	SQ5	2	41947		@		1,600/15,000	1,600/16,000	35
Kodiak C7500 Cab & Chassis, w/34" Wide Frames	99-09	50	SQ5	2	41947		@		1,600/15,000	1,600/16,000	35
Kodiak C8500 Cab & Chassis, w/34" Wide Frames	99-09	50	SQ5	2	41947		@		1,600/15,000	1,600/16,000	35
Lumina	95-00	23	SQ1	1-1/4	24628		AI,GP	3592	200/2,000		30
		48	SQ2	1-1/4	36193	0	JR,GP	36061	300/3,500		60
Malibu 4 Dr.	97-05	34	SQ1	1-1/4	24656	0	GP	3592	200/2,000		15
		41	SQ2	1-1/4	36233		GP	36061	300/3,500		20
Malibu 4 Dr.	04-07	43	SQ2	1-1/4	36317		JR,HM	36071	300/3,500		40
Malibu Except LTZ	08-12	24	SQ2	1-1/4	36479		GP,JR,RB	36065	300/3,500		45
Malibu (Canada Only)	13-13	49	SQ2	1-1/4	36522	0	HM	36061	300/3,500		20
Malibu Except LTZ & Canada Models	13-13	49	SQ2	1-1/4	36522	0	HM	36061	300/3,500		20
Malibu Except LTZ & Canada Models	13-15	42	SQ2	1-1/4	36538	0	HM	36061	300/3,500		35
Malibu (New Body Style)	16-17	23	SQ2	1-1/4	36592	0	GP,JR,EP,TA	36071	300/3,500		80
Malibu Limited LTZ, Except Canada Models (Old Body Style)	16-16	42	SQ2	1-1/4	36538	0	HM	36061	300/3,500		35

- # Titan hitches require use of a 2-1/2" shank Titan ball mount.
- @ Ultra Frame ball mount must be used to achieve maximum weight carrying rating.
- AI Additional installation time may be required.
- CO Will not fit 8 ft. 2500/3500 Series with heavy-duty suspension or four door Crew Cab.
- DB Will not fit 6 ft. bed pickups.
- EP Fascia trimming may be required.
- FS Includes 2 & 4 WD models with heavy duty suspension.
- GP Hitch crosstube concealed behind bumper.
- HK Under vehicle spare tire stowage may be retained with installation of an aftermarket spare tire repositioner. Cutting of rollpan in license plate area required for receiver tube access. Does not fit with bumper.
- HM Hitch crosstube is visible beneath bumper.
- J Under vehicle spare tire stowage is retained.
- JR Exhaust must be temporarily lowered for installation.
- RB Hitch installation can be made easier with a "cuttier" type drill bit.
- SN Hitches produced before 04/28/08 are rated at 1000/10000 WC & 1200/12000 WD.
- TA Trunk access required for hitch installation.

RECEIVER HITCH APPLICATION GUIDE



CHEVROLET

T-ONE						TOW HARNESS						4-FLAT WIRING				REQ. 4 FLAT WIRING		BRAKE CONTROL HARNESS	IN	
PC	T-ONE	FN	IN	AMP	CP	PC	TOW HARN	FN	IN	AMP	CP	TYPE	ELEC	POS	CHOICE 1	CHOICE 2	6-WAY ADAPTER			7-WAY ADAPTER
CHEVROLET (Continued)																				
E3	118315	BN	5	7.5									A	PU3	119180	20252	20320	20321	20224	
E3	118315	BN	5	7.5									A	PU3	119180	20252	20320	20321	20224	
E3	118315	BN	5	7.5									A	PU3	119180	20252	20320	20321	20224	
E3	118315	BN	5	7.5									A	PU3	119180	20252	20320	20321	20224	
E3	118315	BN	5	7.5									A	PU3	119180	20252	20320	20321	20224	
E3	118315	BN	5	7.5									A	PU3	119180	20252	20320	20321	20224	
E3	118315	BN	5	7.5									A	PU3	119180	20252	20320	20321	20224	
E3	118315	BN	5	7.5									A	PU3	119180	20252	20320	20321	20224	
E3	118315	BN	5	7.5									A	PU3	119180	20252	20320	20321	20224	
E3	118315	BN	5	7.5									A	PU3	119180	20252	20320	20321	20224	
E3	118315	BN	5	7.5									A	PU3	119180	20252	20320	20321	20224	
E3	118315	BN	5	7.5									A	PC3,4	119180	20252				
E3	118315	BN	5	7.5									B	PC3,4	119130	119178				
E7	118439	BN	15	7.5									A	PC3,4	119180	20252				
E7	118450	BN	10	7.5									A	PC1,2	119180	20252				
E18	118604	CH	45	4.2,7.5	X								BM	PC3,4	119251	119191				
E16	118576	CH	45	2.1,5.6	X								B,E	PC3,4	119148	119180				
E18	118604	CH	45	4.2,7.5	X								B,E	PC3,4	119148	119180				
E17	118689	CH	45	4.2,7.5	X								BTT	PC3,4	119251	119191				
E17	118602	CH	45	2.1,5.6	X								B,E	PC3,4	119148	119180				

A 2 wire system.
B 3 wire system. Converter required.
BM Multiplexed wiring system. ModuLite® HD Plus or Ultra required.
BN Exterior mounted plug on some or all models. May require an aftermarket electrical mounting box or bracket. (Sold separately)

BTT Shared Brake/Tail/Turn multiplexed wiring system. ModuLite® HD Plus or Ultra required.
CH T-One is equipped with circuit protected ModuLite® module.
E ModuLite® required.

RT3 Round Tube Class III 2"
RT4 Round Tube Class IV 2"
SQ1 Square Tube Class I
SQ2 Square Tube Class II
SQ3 Square Tube Class III
SQ4 Square Tube Class IV
SQ5 Square Tube Class V

RECEIVER HITCHES

RECEIVER HITCH APPLICATION GUIDE

MODEL / STYLE	YEAR	TRAILER HITCHES									
		PC	REC TYPE	REC SIZE	PART #	NO DRILL	FOOTNOTES	OPTIONAL DRAWBAR	WC (LBS.)	WD (LBS.)	IN
CHEVROLET (Continued)											
Malibu Limited, Except LTZ & Canada Models (Old Body Style)	16-16	42	SQ2	1-1/4	36538	0	HM	36061	300/3,500		35
Malibu Classic LS	08-08	43	SQ2	1-1/4	36317		JR, HM	36071	300/3,500		40
Malibu Classic LT	08-08	43	SQ2	1-1/4	36317		JR, HM	36071	300/3,500		40
Malibu LTZ	08-12	24	SQ2	1-1/4	36479		GP, JR, RB	36065	300/3,500		45
Malibu LTZ Except Canada Models	13-13	49	SQ2	1-1/4	36522	0	HM	36061	300/3,500		20
Malibu LTZ Except Canada Models	14-15	42	SQ2	1-1/4	36538	0	HM	36061	300/3,500		35
Malibu Maxx LS	04-07	37	SQ2	1-1/4	36379		HM	36071	300/3,500		25
Malibu Maxx LT	04-07	37	SQ2	1-1/4	36379		HM	36071	300/3,500		25
Malibu SS 4 Dr.	06-07	43	SQ2	1-1/4	36317		JR, X, HM	36071	300/3,500		50
Monte Carlo	95-99	23	SQ1	1-1/4	24628		AI, GP	3592	200/2,000		30
		48	SQ2	1-1/4	36193	0	JR, GP	36061	300/3,500		60
Monte Carlo Except SS Sport Appearance Pkg.	00-05	45	SQ2	1-1/4	36292	0	JR, GP	36061	300/3,500		30
Monte Carlo Except SS Sport Appearance Pkg.	06-07	45	SQ2	1-1/4	36292	0	JR, GP	36061	300/3,500		30
Orlando (Canada Only)	12-13	27	SQ1	1-1/4	24881	0	HM, JR, KH	3593	200/2,000		35
Prizm	98-02	25	SQ1	1-1/4	24579		GP	3593	200/2,000		30
S10 w/Standard Bed & Step Bumper	85-97	34	SQ2	1-1/4	36248	0	GU, HM, RH	36071	300/3,500		35
		34	SQ3	2	75051	0	GP, GU		350/3,500	750/6,000	40
		50	SQ3	2	37136		CN, GU, SB		500/5,000	600/6,000	30
S10 w/Sportside Bed & Non-Towing Bumper	96-97	30	SQ3	2	75085	0			350/3,500	750/6,000	40
S10	98-04	34	SQ2	1-1/4	36248	0	GU, RH, GP	36071	300/3,500		35
		30	SQ3	2	75085	0			350/3,500	750/6,000	40
		50	SQ3	2	37136		AF, CN, GU, ST		500/5,000	600/6,000	30
S10	13-13	53	SQ3	2	75810	0	GP		600/4,000	771/7,710	30
Silverado 1500	99-02	49	RT3	2	37133	0	RO		500/5,000	750/7,500	25
		39	SQ4	2	41534	0	RO		600/6,000	1,200/12,000	20
		54	RT4	2	37130	0	RO		700/7,000	1,200/12,000	25
		30	RT4	2	75362	0	JL		900/6,000	900/8,000	15
		22	RT4	2	75521	0	JL, SZ		900/6,000	1,050/10,500	15
		50	SQ5	2	41932	0	@, HM, JL		1,200/12,000	1,400/14,000	20
Silverado 1500 w/Factory 7-Way	99-13										
Silverado 1500 (Classic)	03-07	49	RT3	2	37133	0			500/5,000	750/7,500	25
		39	SQ4	2	41534	0			600/6,000	1,200/12,000	20
		54	RT4	2	37130	0			700/7,000	1,200/12,000	25
		30	RT4	2	75362	0	JL		900/6,000	900/8,000	15
		22	RT4	2	75521	0	JL, SZ		900/6,000	1,050/10,500	15
Silverado 1500	07-13	30	RT4	2	75362	0	JL		900/6,000	900/8,000	15
		22	RT4	2	75521	0	JL, SZ		900/6,000	1,050/10,500	15
Silverado 1500	14-17	33	RT4	2	75866	0	HM, JL		900/6,000	1,200/12,000	20
		31	SQ4	2	76016	0	GP, JL		900/6,000	1,000/10,000	25
Silverado 1500 HD	01-02	39	SQ4	2	41534	0			600/6,000	1,200/12,000	20
Silverado 1500 HD	01-03	49	RT3	2	37133	0			500/5,000	750/7,500	25
		54	RT4	2	37130	0			700/7,000	1,200/12,000	25
		30	RT4	2	75362	0	JL		900/6,000	900/8,000	15
		22	RT4	2	75521	0	JL, SZ		900/6,000	1,050/10,500	15
		50	SQ5	2	41932	0	@, HM, JL		1,200/12,000	1,400/14,000	20
Silverado 1500 HD w/Factory 7-Way	01-07										
Silverado 1500 HD (Classic)	03-03	39	SQ4	2	41534	0			600/6,000	1,200/12,000	20

- @ Ultra Frame ball mount must be used to achieve maximum weight carrying rating.
- AF Hitch is ONLY rated for Weight Carrying at 3500 lbs. GTW / 350 lbs. TW and DO NOT use Weight Distribution Spring Bars for this Specific Vehicle. Except for long bed pickups.
- AI Additional installation time may be required.
- CN Requires OEM factory bumper for hitch installation.
- GP Hitch crosstube concealed behind bumper.
- GU Will not fit vehicles with factory or aftermarket lower Fascia/Rollpan or Tube Bumper.
- HM Hitch crosstube is visible beneath bumper.
- JL Installation requires OEM bumper and brackets.
- JR Exhaust must be temporarily lowered for installation.

- KH Minor heat shield modification may be required.
- RB Hitch installation can be made easier with a "cutter" type drill bit.
- RH Optional drawbar #36051 required (Sold separately) except for models with ZR2 & Highrider package.
- RO Will not fit Silverado SS.
- SB Will not fit models with short bed.
- ST Will not fit 2WD models with short bed.
- SZ Hitches produced before 03/10/11 are rated at 600/6000 WC.
- X Minor fascia trimming required.

RECEIVER HITCH APPLICATION GUIDE

T-ONE						TOW HARNESS						4-FLAT WIRING				REQ. 4 FLAT WIRING		BRAKE CONTROL HARNESS	IN		
PC	T-ONE	FN	IN	AMP	CP	PC	TOW HARN	FN	IN	AMP	CP	TYPE	ELEC	POS	CHOICE 1	CHOICE 2	6-WAY ADAPTER			7-WAY ADAPTER	7-WAY HARDWIRE
CHEVROLET (Continued)																					
E18	118604	CH	45	4.2,7.5	X								B,E	PC3,4	119148	119180					
E7	118439	BN	15	7.5									A	PC3,4	119180	20252					
E7	118439	BN	15	7.5									A	PC3,4	119180	20252					
													A,E	PC1,2	119148	119180					
E17	118602	CH	45	2.1,5.6	X								B,E	PC3,4	119148	119180					
E17	118602	CH	45	2.1,5.6	X								B,E	PC3,4	119148	119180					
E7	118439	BN	15	7.5									A	PC3,4	119180	20252					
E7	118439	BN	15	7.5									A	PC3,4	119180	20252					
E7	118439	BN	15	7.5									A	PC3,4	119180	20252					
													A	PC3,4	119180	20252					
													B	PC4	119130	119178					
													A	PC3,4	119180	20252					
E16	118565	CH	45	2.1,5.6	X								B,E	SUV3,4	119148	119180	20320	20321			
													B	PC3,4	119130	119178					
E3	118312	BN	5	7.5									A	PU3	119180	20252	20320	20321	20224		
E3	118312	BN	5	7.5									A	PU3	119180	20252	20320	20321	20224		
E4	118359	BN	5	7.5									A	PU3	119180	20252	20320	20321	20224		
													B,E	PU1,2	119148	119180	20320	20321			
						E8	118384	BN,RD	5	7.5		4-Flat	A	PU3	119180	20252	20320	20321	20224	3025-P	5
							20119 20047 118015	RD RD RD	10 5 10			Both 7-Way 7-Way	H	PU3	119180	20252					
						E8	118384	BN,RD	5	7.5		4-Flat	A	PU3	119180	20252	20320	20321	20224	3015-P	5
E8	118384	BN	5	7.5									A	PU3	119180	20252	20320	20321	20224		
E8	118384		5	7.5									A	PU3	119180	20252	20320	20321	20224	3016-P	5
						E8	118384	BN,RD	5	7.5		4-Flat	A	PU3	119180	20252	20320	20321	20224	3025-P	5
						E8	118384	BN,RD	5	7.5		4-Flat	A	PU3	119180	20252	20320	20321	20224	3025-P	5
							118015 20119 20047	RD RD RD	10 10 5			7-Way Both 7-Way	H	PU3	119180	20252					
						E8	118384	BN,RD	5	7.5		4-Flat	A	PU3	119180	20252	20320	20321	20224	3015-P	5

A 2 wire system.
B 3 wire system. Converter required.
BN Exterior mounted plug on some or all models. May require an aftermarket electrical mounting box or bracket. (Sold separately)
CH T-One is equipped with circuit protected ModuLite® module.

E ModuLite® required.
H 3 wire system with OEM standard 2 wire harness.
RD For vehicles equipped with factory tow package may require additional components or may be used as a replacement harness.

RT3 Round Tube Class III 2"
RT4 Round Tube Class IV 2"
SQ1 Square Tube Class I
SQ2 Square Tube Class II
SQ3 Square Tube Class III
SQ4 Square Tube Class IV
SQ5 Square Tube Class V

RECEIVER HITCH APPLICATION GUIDE

MODEL / STYLE	YEAR	TRAILER HITCHES									
		PC	REC TYPE	REC SIZE	PART #	NO DRILL	FOOTNOTES	OPTIONAL DRAWBAR	WC (LBS.)	WD (LBS.)	IN
CHEVROLET (Continued)											
Silverado 1500 HD (Classic)	05-07	49	RT3	2	37133	0			500/5,000	750/7,500	25
		39	SQ4	2	41534	0			600/6,000	1,200/12,000	20
		54	RT4	2	37130	0			700/7,000	1,200/12,000	25
		30	RT4	2	75362	0	JL		900/6,000	900/8,000	15
		22	RT4	2	75521	0	JL,SZ		900/6,000	1,050/10,500	15
		50	SQ5	2	41932	0	@,HM,JL		1,200/12,000	1,400/14,000	20
Silverado 2500	99-02	49	RT3	2	37133	0			500/5,000	750/7,500	25
		39	SQ4	2	41534	0			600/6,000	1,200/12,000	20
		54	RT4	2	37130	0			700/7,000	1,200/12,000	25
		30	RT4	2	75362	0	JL		900/6,000	900/8,000	15
		22	RT4	2	75521	0	JL,SZ		900/6,000	1,050/10,500	15
		50	SQ5	2	41932	0	@,HM,JL		1,200/12,000	1,400/14,000	20
Silverado 2500 w/Factory 7-Way	99-04	59	SQ5	2-1/2	45512	0	#		1,200/12,000	1,700/14,000	20
		49	RT3	2	37133	0			500/5,000	750/7,500	25
		39	SQ4	2	41534	0			600/6,000	1,200/12,000	20
		54	RT4	2	37130	0			700/7,000	1,200/12,000	25
		30	RT4	2	75362	0	JL		900/6,000	900/8,000	15
		22	RT4	2	75521	0	JL,SZ		900/6,000	1,050/10,500	15
Silverado 2500 HD	01-02	46	SQ4	2	41544	0	HM,SA		600/6,000	1,200/12,000	20
		34	RT4	2	75550	0	CS,FS,JL,LT		600/6,000	1,100/11,000	20
		35	SQ5	2	41944	0	@,CS,FS,HM,LT		1,950/13,000	1,600/16,000	25
		58	SQ5	2-1/2	45517	0	#,CS,FS,LT		1,300/13,000	1,700/17,000	25
		60	SQ5	2-1/2	45519	0	#,CS,FS,LT		2,000/18,000	2,500/18,000	25
		59	SQ5	2-1/2	45512	0	#		1,200/12,000	1,700/14,000	20
Silverado 2500 HD (Classic)	03-04	46	SQ4	2	41544	0	HM,SA		600/6,000	1,200/12,000	20
		34	RT4	2	75550	0	CS,FS,JL,LT		600/6,000	1,100/11,000	20
		35	SQ5	2	41944	0	@,CS,FS,HM,LT		1,950/13,000	1,600/16,000	25
		58	SQ5	2-1/2	45517	0	#,CS,FS,LT		1,300/13,000	1,700/17,000	25
		60	SQ5	2-1/2	45519	0	#,CS,FS,LT		2,000/18,000	2,500/18,000	25
		59	SQ5	2-1/2	45512	0	#		1,200/12,000	1,700/14,000	20
Silverado 2500 HD (Classic)	03-07	46	SQ4	2	41544	0	HM,SA		600/6,000	1,200/12,000	20
		34	RT4	2	75550	0	CS,FS,JL,LT		600/6,000	1,100/11,000	20
		35	SQ5	2	41944	0	@,CS,FS,HM,LT		1,950/13,000	1,600/16,000	25
		58	SQ5	2-1/2	45517	0	#,CS,FS,LT		1,300/13,000	1,700/17,000	25
		60	SQ5	2-1/2	45519	0	#,CS,FS,LT		2,000/18,000	2,500/18,000	25
		59	SQ5	2-1/2	45512	0	#		1,200/12,000	1,700/14,000	20
Silverado 2500 HD	07-10	34	RT4	2	75550	0	CS,FS,JL,LT		600/6,000	1,100/11,000	20
		35	SQ5	2	41944	0	@,CS,FS,HM,LT		1,950/13,000	1,600/16,000	25
		58	SQ5	2-1/2	45517	0	#,CS,FS,LT		1,300/13,000	1,700/17,000	25
		60	SQ5	2-1/2	45519	0	#,CS,FS,LT		2,000/18,000	2,500/18,000	25
		43	SQ4	2	75707	0	CS,FS,GP,JL,LT		800/8,000	1,200/12,000	20
		50	SQ5	2	41942	0	@,CS,FS,GP,JL,KH,LT		1,500/15,000	1,600/16,000	20
Silverado 2500 HD	11-14	67	SQ5	2-1/2	45510	0	#,CS,FS,HM,JL,KH,LT		2,000/18,000	2,500/18,000	60
		42	SQ4	2	75906	0	HM,JL		800/8,000	1,200/12,000	30
		48	SQ5	2	41950	0	@,CS,FS,GP,JL,KH,LT		1,700/15,000	1,700/17,000	60
		57	SQ5	2-1/2	45511	0	#,HM		2,700/20,000	2,700/20,000	60
		46	SQ4	2	41544	0	HM,SA		600/6,000	1,200/12,000	20
		34	RT4	2	75550	0	CS,FS,JL,LT		600/6,000	1,100/11,000	20
Silverado 3500	01-02	35	SQ5	2	41944	0	@,CS,FS,HM,LT		1,950/13,000	1,600/16,000	25
		58	SQ5	2-1/2	45517	0	#,CS,FS,LT		1,300/13,000	1,700/17,000	25
		60	SQ5	2-1/2	45519	0	#,CS,FS,LT		2,000/18,000	2,500/18,000	25
		60	SQ5	2-1/2	45519	0	#,CS,FS,LT		2,000/18,000	2,500/18,000	25

Titan hitches require use of a 2-1/2" shank Titan ball mount.
 @ Ultra Frame ball mount must be used to achieve maximum weight carrying rating.
 CS Will fit with full-size spare tire stowed under vehicle.
 FS Includes 2 & 4 WD models with heavy duty suspension.
 GP Hitch crosstube concealed behind bumper.
 HM Hitch crosstube is visible beneath bumper.

JL Installation requires OEM bumper and brackets.
 KH Minor heat shield modification may be required.
 LT Requires removal of factory hitch if equipped.
 SA Requires drilling on 6 ft. bed models.
 SZ Hitches produced before 03/10/11 are rated at 600/6000 WC.

RECEIVER HITCH APPLICATION GUIDE

T-ONE						TOW HARNESS						4-FLAT WIRING				REQ. 4 FLAT WIRING		BRAKE CONTROL HARNESS	IN		
PC	T-ONE	FN	IN	AMP	CP	PC	TOW HARN	FN	IN	AMP	CP	TYPE	ELEC	POS	CHOICE 1	CHOICE 2	6-WAY ADAPTER			7-WAY ADAPTER	7-WAY HARDWIRE
CHEVROLET (Continued)																					
						E8	118384	BN,RD	5	7.5		4-Flat	A	PU3	119180	20252	20320	20321	20224	3015-P	5
						E8	118384	BN,RD	5	7.5		4-Flat	A	PU3	119180	20252	20320	20321	20224	3025-P	5
							20119 118015 20047	RD RD RD	10 10 5			Both 7-Way 7-Way	H	PU3	119180	20252					
						E8	118384	BN,RD	5	7.5		4-Flat	A	PU3	119180	20252	20320	20321	20224	3015-P	5
						E8	118384	BN,RD	5	7.5		4-Flat	A	PU3	119180	20252	20320	20321	20224	3025-P	5
						E8	118384	BN,RD	5	7.5		4-Flat	A	PU3	119180	20252	20320	20321	20224	3025-P	5
							118015 20047 20119	RD RD RD	10 5 10			7-Way 7-Way Both	H	PU3	119180	20252					
						E8	118384	BN,RD	5	7.5		4-Flat	A	PU3	119180	20252	20320	20321	20224	3015-P	5
						E8	118384	BN,RD	5	7.5		4-Flat	A	PU3	119180	20252	20320	20321	20224	3015-P	5
E8	118384	BN	5	7.5									A	PU3	119180	20252	20320	20321	20224		
E8	118384	BN	5	7.5									A	PU3	119180	20252	20320	20321	20224		
E8	118384	BN	5	7.5									A	PU3	119180	20252	20320	20321	20224		
													A	PU3	119180	20252	20320	20321	20224	3016-P	5
						E8	118384	BN,RD	5	7.5		4-Flat	A	PU3	119180	20252	20320	20321	20224	3025-P	5

A 2 wire system.
BN Exterior mounted plug on some or all models. May require an aftermarket electrical mounting box or bracket. (Sold separately)

H 3 wire system with OEM standard 2 wire harness.
RD For vehicles equipped with factory tow package may require additional components or may be used as a replacement harness.

RT3 Round Tube Class III 2"
RT4 Round Tube Class IV 2"
SQ4 Square Tube Class IV
SQ5 Square Tube Class V

RECEIVER HITCH APPLICATION GUIDE

MODEL / STYLE	YEAR	TRAILER HITCHES									
		PC	REC TYPE	REC SIZE	PART #	NO DRILL	FOOTNOTES	OPTIONAL DRAWBAR	WC (LBS.)	WD (LBS.)	IN
CHEVROLET (Continued)											
Silverado 3500 Cab & Chassis, w/34" Wide Frames (Classic)	01-07	29	SQ5	2	41936		@		1,200/12,000		30
		50	SQ5	2	41938		@,CC		1,200/12,000	1,500/15,000	40
		50	SQ5	2	41947		@		1,600/15,000	1,600/16,000	35
Silverado 3500 w/Factory 7-Way	01-07										
Silverado 3500 (Classic)	03-07	46	SQ4	2	41544	0	HM,SA		600/6,000	1,200/12,000	20
		34	RT4	2	75550	0	CS,FS,JL,LT		600/6,000	1,100/11,000	20
		35	SQ5	2	41944	0	@,CS,FS,HM,LT		1,950/13,000	1,600/16,000	25
		58	SQ5	2-1/2	45517	0	#,CS,FS,LT		1,300/13,000	1,700/17,000	25
		60	SQ5	2-1/2	45519	0	#,CS,FS,LT		2,000/18,000	2,500/18,000	25
Silverado 3500 HD	07-10	34	RT4	2	75550	0	CS,FS,JL,LT		600/6,000	1,100/11,000	20
		35	SQ5	2	41944	0	@,CS,FS,HM,LT		1,950/13,000	1,600/16,000	25
		58	SQ5	2-1/2	45517	0	#,CS,FS,LT		1,300/13,000	1,700/17,000	25
		60	SQ5	2-1/2	45519	0	#,CS,FS,LT		2,000/18,000	2,500/18,000	25
Silverado 3500 HD Cab & Chassis, w/34" Wide Frames	07-16	29	SQ5	2	41936		@		1,200/12,000		30
		50	SQ5	2	41938		@,CC		1,200/12,000	1,500/15,000	40
		50	SQ5	2	41947		@		1,600/15,000	1,600/16,000	35
Silverado 3500 HD w/Factory 7-Way	07-16										
Silverado 3500 HD	11-14	43	SQ4	2	75707	0	CS,FS,GP,JL,LT		800/8,000	1,200/12,000	20
		50	SQ5	2	41942	0	@,CS,FS,GP,JL,KH,LT		1,500/15,000	1,600/16,000	20
		67	SQ5	2-1/2	45510		#,CS,FS,HM,JL,KH,LT		2,000/18,000	2,500/18,000	60
Silverado 3500 HD	15-16	42	SQ4	2	75906	0	HM,JL		800/8,000	1,200/12,000	30
		48	SQ5	2	41950	0	@,CS,FS,GP,JL,KH,LT		1,700/15,000	1,700/17,000	60
		57	SQ5	2-1/2	45511		#,HM		2,700/20,000	2,700/20,000	60
Sonic 4 Dr. Sedan	12-15	20	SQ1	1-1/4	24876	0	GP	3590	200/2,000		20
Sonic 5 Dr. Hatchback	12-16	25	SQ1	1-1/4	24878	0	HB,HM,JR	3590	200/2,000		20
Spark Except w/Ground Effects	13-15	24	SQ1	1-1/4	24893		GP,JR	3594	200/2,000		25
Spark	16-17	18	SQ1	1-1/4	24941	0	DU,GP,X	3593	200/2,000		45
Spark LT w/Ground Effects	13-15	24	SQ1	1-1/4	24894		GP,JR	3594	200/2,000		25
Suburban w/Factory 7-Way	00-11										
Suburban	07-11										
Suburban 1500 w/Amber Turn Signals	00-02	50	SQ3	2	37136				500/5,000	600/6,000	30
		29	RT4	2	75725	0	CN,HM		900/6,000	1,000/10,000	15
		30	SQ5	2	41930		@,CN,HM		1,000/10,000	1,200/12,000	35
Suburban 1500 w/Amber Turn Signals	03-06	50	SQ3	2	37136				500/5,000	600/6,000	30
		29	RT4	2	75725	0	CN,HM		900/6,000	1,000/10,000	15
		30	SQ5	2	41930		@,CN,HM		1,000/10,000	1,200/12,000	35
Suburban 2500 w/Amber Turn Signals	00-02	50	SQ3	2	37136				500/5,000	600/6,000	30
		29	RT4	2	75725	0	CN,HM		900/6,000	1,000/10,000	15
		30	SQ5	2	41930		@,CN,HM		1,000/10,000	1,200/12,000	35
		53	SQ5	2-1/2	45515		#		1,200/12,000	1,700/14,000	50
Suburban 2500 w/Amber Turn Signals	03-06	50	SQ3	2	37136				500/5,000	600/6,000	30
		29	RT4	2	75725	0	CN,HM		900/6,000	1,000/10,000	15
		30	SQ5	2	41930		@,CN,HM		1,000/10,000	1,200/12,000	35
Suburban C1500	92-99	50	SQ3	2	37136				500/5,000	600/6,000	30
		37	SQ3	2	75037		HM		500/5,000	750/7,500	30
		41	SQ4	2	41511		HM		600/6,000	1,000/10,000	30

- # Titan hitches require use of a 2-1/2" shank Titan ball mount.
- @ Ultra Frame ball mount must be used to achieve maximum weight carrying rating.
- CC Requires minimum of 19" from end of frame rail to spring shackle bracket.
- CN Requires OEM factory bumper for hitch installation.
- CS Will fit with full-size spare tire stowed under vehicle.
- DU Fascia removal required.
- FS Includes 2 & 4 WD models with heavy duty suspension.
- GP Hitch crosstube concealed behind bumper.

- HB Slight fascia deformation may occur on some models.
- HM Hitch crosstube is visible beneath bumper.
- JL Installation requires OEM bumper and brackets.
- JR Exhaust must be temporarily lowered for installation.
- KH Minor heat shield modification may be required.
- LT Requires removal of factory hitch if equipped.
- SA Requires drilling on 6 ft. bed models.
- X Minor fascia trimming required.

RECEIVER HITCH APPLICATION GUIDE

T-ONE						TOW HARNESS						4-FLAT WIRING				REQ. 4 FLAT WIRING		BRAKE CONTROL HARNESS	IN		
PC	T-ONE	FN	IN	AMP	CP	PC	TOW HARN	FN	IN	AMP	CP	TYPE	ELEC	POS	CHOICE 1	CHOICE 2	6-WAY ADAPTER			7-WAY ADAPTER	7-WAY HARDWIRE
CHEVROLET (Continued)																					
													C	PU1,2	119180	119148	20320	20321	20224		
							20119 20047 118015	RD RD RD	10 5 10			Both 7-Way 7-Way	H	PU3	119180	20252					
						E8	118384	BN,RD	5	7.5		4-Flat	A	PU3	119180	20252	20320	20321	20224	3015-P	5
E8	118384	BN	5	7.5									A	PU3	119180	20252	20320	20321	20224		
													C	PU1,2	119180	119148	20320	20321	20224		
							118015 20047 20119	RD RD RD	10 5 10			7-Way 7-Way Both	A	PU3	119180	20252					
E8	118384	BN	5	7.5									A	PU3	119180	20252	20320	20321	20224		
													A	PU3	119180	20252	20320	20321	20224	3016-P	5
													BT	PC3,4	119251	119191					
													BT	PC3,4	119251	119191					
E19	118575	CH	45	2.1,5.6	X								BM	PC3,4	119251	119191					
E18	118694	CH	45	4.2,7.5	X								BT	PC3,4	119251	119191					
E19	118575	CH	45	2.1,5.6	X								BM	PC3,4	119251	119191					
							20119 20047 118015	RD RD RD	10 5 10			Both 7-Way 7-Way	H	SUV6	119180	20252					
						E8	118384	BN,RD	5	7.5		4-Flat	H	SUV6	119180	20252					
E8	118384	BN	5	7.5									A	SUV6	119180	20252	20320	20321	20224	3025-P	5
E8	118384	BN	5	7.5									A	SUV6	119180	20252	20320	20321	20224	3015-P	5
E8	118384	BN	5	7.5									A	SUV6	119180	20252	20320	20321	20224	3025-P	5
E8	118384	BN	5	7.5									A	SUV6	119180	20252	20320	20321	20224	3015-P	5
E3	118319	BN	5	7.5									A	SUV6	119180	20252	20320	20321	20224		

A 2 wire system.
BM Multiplexed wiring system. ModuLite® HD Plus or Ultra required.
BN Exterior mounted plug on some or all models. May require an aftermarket electrical mounting box or bracket. (Sold separately)
BT Shared Brake/Tail multiplexed wiring system. ModuLite® HD Plus or Ultra required.

C 2 or 3 wire system determine at installation.
CH T-One is equipped with circuit protected ModuLite® module.
H 3 wire system with OEM standard 2 wire harness.
RD For vehicles equipped with factory tow package may require additional components or may be used as a replacement harness.

RT4 Round Tube Class IV 2"
SQ1 Square Tube Class I
SQ3 Square Tube Class III
SQ4 Square Tube Class IV
SQ5 Square Tube Class V

RECEIVER HITCH APPLICATION GUIDE

MODEL / STYLE	YEAR	TRAILER HITCHES									
		PC	REC TYPE	REC SIZE	PART #	NO DRILL	FOOTNOTES	OPTIONAL DRAWBAR	WC (LBS.)	WD (LBS.)	IN
CHEVROLET (Continued)											
Suburban C2500	92-99	50	SQ3	2	37136				500/5,000	600/6,000	30
		37	SQ3	2	75037		HM		500/5,000	750/7,500	30
		41	SQ4	2	41511		HM		600/6,000	1,000/10,000	30
Suburban K1500	92-99	50	SQ3	2	37136				500/5,000	600/6,000	30
		37	SQ3	2	75037		HM		500/5,000	750/7,500	30
		41	SQ4	2	41511		HM		600/6,000	1,000/10,000	30
Suburban K2500	92-99	50	SQ3	2	37136				500/5,000	600/6,000	30
		37	SQ3	2	75037		HM		500/5,000	750/7,500	30
		41	SQ4	2	41511		HM		600/6,000	1,000/10,000	30
Tahoe	95-00	50	SQ3	2	37136				500/5,000	600/6,000	30
		37	SQ3	2	75037		HM		500/5,000	750/7,500	30
		41	SQ4	2	41511		HM		600/6,000	1,000/10,000	30
Tahoe w/Amber Turn Signals	00-02	50	SQ3	2	37136				500/5,000	600/6,000	30
		29	RT4	2	75725	0	CN, HM		900/6,000	1,000/10,000	15
Tahoe w/Factory 7-Way	00-11										
Tahoe w/Amber Turn Signals	03-06	50	SQ3	2	37136				500/5,000	600/6,000	30
		29	RT4	2	75725	0	CN, HM		900/6,000	1,000/10,000	15
Tahoe	07-11										
Tracker	98-98	25	SQ1	1-1/4	24622	0	HM	3593	200/2,000		20
Tracker	99-04	29	SQ1	1-1/4	24673	0	HM	3591	200/2,000		15
		29	SQ3	2	41537	0	HM		350/3,500		15
TrailBlazer w/Factory 7-Way	02-09										
Traverse	09-12	19	RT3	2	75528	0	GP, JR, TN		750/5,000	750/7,500	25
Traverse w/Factory 7-Way	09-12										
Traverse	13-17	19	RT3	2	75528	0	GP, JR, TN		750/5,000	750/7,500	25
Trax	13-16	25	RT2	1-1/4	36554	0	HM, JR	36061	300/3,500		40
Uplander	05-08	27	SQ2	1-1/4	36361		AL, GP, JR	36061	300/3,500		40
		22	SQ3	2	75278		AL, GP, JR		350/3,500	500/5,000	40
Uplander (Canada Only)	09-09	27	SQ2	1-1/4	36361		AL, GP, JR	36061	300/3,500		40
		22	SQ3	2	75278		AL, GP, JR		350/3,500	500/5,000	40
Venture	97-05	27	SQ1	1-1/4	24721		AL, GP, JR	3592	200/2,000		30
		27	SQ2	1-1/4	36361		AL, GP, JR	36061	300/3,500		40
		22	SQ3	2	75278		AL, GP, JR		350/3,500	500/5,000	40
Volt	16-17	18	SQ1		24947	0	GP, DU, SV, JR	3593	200/2,000		60
CHRYSLER											
200 4 Dr. Sedan	11-11	28	SQ1	1-1/4	24871	0	GP, JR	3594	200/2,000		15
200 Convertible	11-11	28	SQ1	1-1/4	24871	0	GP, JR	3594	200/2,000		15
200 4 Dr. Sedan	12-14	28	SQ1	1-1/4	24871	0	GP, JR	3594	200/2,000		15
200 Convertible	12-14	28	SQ1	1-1/4	24871	0	GP, JR	3594	200/2,000		15
200 4 Dr. Sedan	15-16	27	SQ1	1-1/4	24919	0	GP, SV	3593	200/2,000		20
300	05-07	27	SQ2	1-1/4	36548	0	HM	36061	300/3,500		30
300	08-10	27	SQ2	1-1/4	36548	0	HM	36061	300/3,500		30
300	11-14	27	SQ2	1-1/4	36548	0	HM	36061	300/3,500		40
300	15-16	27	SQ2	1-1/4	36548	0	HM	36061	300/3,500		30
300M	99-01	37	SQ2	1-1/4	36275		HM, JR	36071	300/3,500		30
300M Except Special	02-04	37	SQ2	1-1/4	36275		HM, JR	36071	300/3,500		30

AL Additional installation time required for vehicles equipped with load leveling compressor.
 CN Requires OEM factory bumper for hitch installation.
 DU Fascia removal required.
 GP Hitch crosstube concealed behind bumper.

HM Hitch crosstube is visible beneath bumper.
 JR Exhaust must be temporarily lowered for installation.
 SV Trimming or removal of under body appearance panel may be required.
 TN Hitches produced before 07/09/12 are rated at 500/5000 WC & 500/5000 WD.

RECEIVER HITCH APPLICATION GUIDE



CHRYSLER

T-ONE						TOW HARNESS						4-FLAT WIRING				REQ. 4 FLAT WIRING		7-WAY HARDWIRE	BRAKE CONTROL HARNESS	IN		
PC	T-ONE	FN	IN	AMP	CP	PC	TOW HARN	FN	IN	AMP	CP	TYPE	ELEC	POS	CHOICE 1	CHOICE 2	6-WAY ADAPTER				7-WAY ADAPTER	
CHEVROLET (Continued)																						
E3	118319	BN	5	7.5									A	SUV6	119180	20252	20320	20321	20224			
E3	118319	BN	5	7.5									A	SUV6	119180	20252	20320	20321	20224			
E3	118319	BN	5	7.5									A	SUV6	119180	20252	20320	20321	20224			
E3	118319	BN	5	7.5									A	SUV6	119180	20252	20320	20321	20224			
E8	118384	BN	5	7.5									A	SUV6	119180	20252	20320	20321	20224	3025-P	5	
							20119 20047 118015	RD RD RD	10 5 10			Both 7-Way 7-Way	H	SUV6	119180	20252						
E8	118384	BN	5	7.5									A	SUV6	119180	20252	20320	20321	20224	3015-P	5	
						E8	118384	BN,RD	5	7.5		4-Flat	H	SUV6	119180	20252						
E5	118372	HG	5	2.1,5									B	SUV1,2	119130	119178						
E5	118372	HG	5	2.1,5									B	SUV3	119130	119178	20320	20321	20224			
						E8	118384 20119 20047 118015	BN,RD RD RD RD	5 10 5 10	7.5		4-Flat Both 7-Way 7-Way	H	SUV6	119180	20252						
E7	118450	BN	10	7.5		E8	118384 20047 118015 20119	BN,RD RD RD RD	5 5 10 10	7.5		4-Flat 7-Way 7-Way Both	N N	SUV1,2 SUV6		119251 119251	20320	20321		3026-P	5	
E10	118270	BN	20	7.5		E16	118271	BN	20			7-Way	B,E	SUV1,2	119148	119180	20320	20321	20224	3026-P	5	
E16	118659	CH	45	4.2,7.5	X								B,E	SUV3,4	119148	119180	20320	20321				
E10	118396	BN	15	7.5									A	SUV1,2	119180	20252	20320	20321	20224			
E10	118396	BN	15	7.5									A	SUV1,2	119180	20252	20320	20321	20224			
E8	118355	HG	10	2.1,5									B	SUV3	119130	119178	20320	20321	20224			
E17	118726	CH,BN	45	5.7,5	X								B,E	PC1,2	119148	119180						
CHRYSLER																						
E18	118550	BN,CH	45	2.1,5.6	X								B,E	PC1,2	119148	119180						
E18	118550	BN,CH	45	2.1,5.6	X								B,E	PC1,2	119148	119180						
E17	118577	CH	45	2.1,5.6	X								N	PC1,2		119251						
E17	118577	CH	45	2.1,5.6	X								N	PC1,2		119251						
E15	118638	CH	45	2.1,5.6	X								A,E	PC3,4	119148	119180						
E7	118404		10	7.5									A	PC3,4	119180	20252						
E14	118406	CH	15	2.1,5.6	X								B,E	PC3,4	119148	119180						
E16	118600	CH	25	2.1,5.6	X								N	PC3,4		119251						
E15	118658	CH	45	4.2,7.5	X								A,E	PC3,4	119148	119180						
E12	118364	BN,HG	15	2.1,5									B	PC1,2	119130	119178						
E12	118364	BN,HG	15	2.1,5									B	PC1,2	119130	119178						

- A** 2 wire system.
- B** 3 wire system. Converter required.
- BN** Exterior mounted plug on some or all models. May require an aftermarket electrical mounting box or bracket. (Sold separately)
- CH** T-One is equipped with circuit protected ModuLite® module.
- E** ModuLite® required.
- H** 3 wire system with OEM standard 2 wire harness.
- HG** T-One incorporates taillight converter.
- N** DO NOT cut or splice vehicle wiring. Only use approved T-One or see auto dealer for trailer tow wiring kit.
- RD** For vehicles equipped with factory tow package may require additional components or may be used as a replacement harness.

- RT2** Round Tube Class II 1-1/4"
- RT3** Round Tube Class III 2"
- RT4** Round Tube Class IV 2"
- SQ1** Square Tube Class I
- SQ2** Square Tube Class II
- SQ3** Square Tube Class III
- SQ4** Square Tube Class IV

RECEIVER HITCHES

RECEIVER HITCH APPLICATION GUIDE

MODEL / STYLE	YEAR	TRAILER HITCHES									
		PC	REC TYPE	REC SIZE	PART #	NO DRILL	FOOTNOTES	OPTIONAL DRAWBAR	WC (LBS.)	WD (LBS.)	IN
CHRYSLER (Continued)											
Aspen	07-08	18	SQ4	2	75162		AI		600/6,000	900/9,000	50
Aspen w/Factory 7-Way	07-08										
Aspen	09-09	18	SQ4	2	75162		AI		600/6,000	900/9,000	50
Aspen w/Factory 7-Way	09-09										
Cirrus	95-00	40	SQ2	1-1/4	36301		JR,HM	36061	300/3,500		60
Concorde	93-97	43	SQ2	1-1/4	36170		JR,TA,HM	36061	300/3,500		40
Concorde	98-01	42	SQ2	1-1/4	36270†		†,HM	36071	300/3,500		35
Concorde	02-02	36	SQ2	1-1/4	36274		JR,GP	36061	300/3,500		30
Concorde	03-04	36	SQ2	1-1/4	36274		JR,GP	36061	300/3,500		30
Intrepid (Canada Only)	93-97	43	SQ2	1-1/4	36170		JR,TA,HM	36061	300/3,500		40
Intrepid (Canada Only)	98-04	37	SQ2	1-1/4	36268		JR,HM	36053	300/3,500		30
LHS	94-97	43	SQ2	1-1/4	36170		JR,TA,HM	36063	300/3,500		40
LHS	99-99	36	SQ2	1-1/4	36274		JR,GP	36061	300/3,500		30
LHS	00-01	36	SQ2	1-1/4	36274		JR,GP	36061	300/3,500		30
Pacifica	04-08	37	RT3	2	75522	0	JR		350/3,500	500/5,000	45
Pacifica w/Factory 7-Way	04-08										
Pacifica Except LX & Touring	17-17	26	RT2	1-1/4	36798	0	GP,JR,SV,KH	36071	300/3,500		45
		28	RT3	2	76046	0	GP,JR,SV,KH		675/4,500	675/5,000	45
Pacifica Except Touring L, Touring L Plus & Limited	17-17	26	RT2	1-1/4	36798	0	GP,JR,SV,KH	36071	300/3,500		45
		28	RT3	2	76046	0	GP,JR,SV,KH		675/4,500	675/5,000	45
PT Cruiser	01-04	31	SQ1	1-1/4	24759		JR,GP	3593	200/2,000		30
PT Cruiser	05-10	31	SQ1	1-1/4	24759		JR,GP	3593	200/2,000		30
PT Cruiser Convertible	05-09	31	SQ1	1-1/4	24759		JR,GP	3593	200/2,000		30
Sebring 4 Dr.	01-06	40	SQ2	1-1/4	36301		JR,HM	36061	300/3,500		60
Sebring Convertible	01-06	29	SQ1	1-1/4	24711		GP	3592	200/2,000		15
Sebring Convertible	07-10	28	SQ1	1-1/4	24871	0	GP,JR	3594	200/2,000		15
Sebring Except Convertible	07-10	28	SQ1	1-1/4	24871	0	GP,JR	3594	200/2,000		15
		31	SQ2	1-1/4	36448		GP,JR	36065	300/3,500		30
Town & Country	96-00	25	SQ1	1-1/4	24702	0	HM	3593	200/2,000		30
		23	SQ2	1-1/4	36296	0	GP	36071	300/3,500		30
		30	RT3	2	75119				350/3,500	500/5,000	30
		50	SQ3	2	37136				500/5,000	600/6,000	40
Town & Country	01-03	25	SQ1	1-1/4	24702	0	HM	3593	200/2,000		30
		23	SQ2	1-1/4	36296	0	GP	36071	300/3,500		30
		30	RT3	2	75119	0			350/3,500	500/5,000	30
		50	SQ3	2	37136				500/5,000	600/6,000	40
Town & Country Except w/Stow & Go Seats	04-07	25	SQ1	1-1/4	24702	0	HM	3593	200/2,000		30
		23	SQ2	1-1/4	36296	0	GP	36071	300/3,500		30
		30	RT3	2	75119	0			350/3,500	500/5,000	30
		50	SQ3	2	37136				500/5,000	600/6,000	40
Town & Country w/Stow & Go Seats	05-07	45	SQ2	1-1/4	36320	0	HM	36071	300/3,500		25
		54	SQ3	2	75305	0			350/3,500	400/4,000	25
Town & Country	08-10	24	SQ2	1-1/4	36455	0	GP,JR	36061	300/3,500		20
		21	SQ3	2	75579	0	GP,JR		400/4,000	500/5,000	20
Town & Country	11-16	24	SQ2	1-1/4	36455	0	GP,JR	36061	300/3,500		20
		21	SQ3	2	75579	0	GP,JR		400/4,000	500/5,000	20
Voyager	01-03	25	SQ1	1-1/4	24702	0	HM	3593	200/2,000		30
		23	SQ2	1-1/4	36296	0	GP	36071	300/3,500		30
		30	RT3	2	75119	0			350/3,500	500/5,000	30
		50	SQ3	2	37136				500/5,000	600/6,000	40

† Available while supply lasts.
 AI Additional installation time may be required.
 GP Hitch cross-tube concealed behind bumper.
 HM Hitch cross-tube is visible beneath bumper.

JR Exhaust must be temporarily lowered for installation.
 KH Minor heat shield modification may be required.
 SV Trimming or removal of under body appearance panel may be required.
 TA Trunk access required for hitch installation.

RECEIVER HITCH APPLICATION GUIDE



CHRYSLER

PC	T-ONE					TOW HARNESS						4-FLAT WIRING				REQ. 4 FLAT WIRING		BRAKE CONTROL HARNESS	IN		
	T-ONE	FN	IN	AMP	CP	PC	TOW HARN	FN	IN	AMP	CP	TYPE	ELEC	POS	CHOICE 1	CHOICE 2	6-WAY ADAPTER			7-WAY ADAPTER	7-WAY HARDWIRE
CHRYSLER (Continued)																					
E15	118390	BN,CH	45	2,1,5,6	X	E3	118381 20135	BN,RD RD	5 10	7.5		4-Flat Both	B,E H	SUV1,2 SUV6	119148 119180	119180 20252	20320	20321	20224	3020-P	5
E15	118390	BN,CH	45	2,1,5,6	X	E8	118384 20119 118015	BN,RD RD RD	5 10 10	7.5		4-Flat Both 7-Way	B,E H	SUV1,2 SUV6	119148 119180	119180 20252	20320	20321	20224	3020-P	5
												B	PC3,4	119130	119178						
												B	PC3,4	119130	119178						
E12	118364	BN,HG	15	2,1,5								B	PC1,2	119130	119178						
E12	118364	BN,HG	15	2,1,5								B	PC1,2	119130	119178						
												B	PC1,2	119130	119178						
												B	PC3,4	119130	119178						
E12	118364	BN,HG	15	2,1,5								B	PC1,2	119130	119178						
												B	PC3,4	119130	119178						
E12	118364	BN,HG	15	2,1,5								B	PC3,4	119130	119178						
												B	PC3,4	119130	119178						
E17	118303	BN,CH	25	2,1,5,6	X	E3	118381 20135	BN,RD RD	5 10	7.5		4-Flat Both	B,E H	SUV1,2 SUV6	119148 119180	119180 20252	20320	20321	20224		
E15	118712	CH,BN	45	4,2,7,5	X								A,E	SUV1,2	119148	119180					
E18	118723	CH,BN	45		X								A,E	SUV1,2	119148	119180					
E19	118462	BN,CH	45	2,1,4,2	X								B	SUV1,2	119130	119178					
E19	118462	BN,CH	45	2,1,4,2	X								B,E	SUV1,2	119148	119180	20320	20321			
													B,E	SUV1,2	119148	119180					
													B	PC3,4	119130	119178					
													B	PC3,4	119130	119178					
E19	118444	BN,CH	45	2,1,4,2	X								B,E	PC3,4	119148	119180					
E19	118444	BN,CH	45	2,1,4,2	X								B,E	PC3,4	119148	119180					
E10	118334	HG	20	2,1,5									B	SUV1,2	119130	119178	20320	20321	20224		
E7	118376	HG	15	2,1,5									B	SUV1,2	119130	119178	20320	20321	20224		
E7	118300		20	7,5									A	SUV1,2	119180	20252	20320	20321	20224		
E7	118300		20	7,5									A	SUV1,2	119180	20252	20320	20321	20224		
E18	118552	CH	45	4,2,7,5	X								A,E	SUV1,2	119148	119180	20320	20321	20224		
E18	118534	BN,CH	45	4,2,7,5	X								C,E	SUV1,2	119180	119148	20320	20321	20224		
E7	118376	HG	15	2,1,5									B	SUV1,2	119130	119178	20320	20321	20224		

- A** 2 wire system.
- B** 3 wire system. Converter required.
- BN** Exterior mounted plug on some or all models. May require an aftermarket electrical mounting box or bracket. (Sold separately)
- C** 2 or 3 wire system determine at installation.
- CH** T-One is equipped with circuit protected ModuLite® module.
- E** ModuLite® required.
- H** 3 wire system with OEM standard 2 wire harness.
- HG** T-One incorporates taillight converter.
- RD** For vehicles equipped with factory tow package may require additional components or may be used as a replacement harness.

- RT2** Round Tube Class II 1-1/4"
- RT3** Round Tube Class III 2"
- SQ1** Square Tube Class I
- SQ2** Square Tube Class II
- SQ3** Square Tube Class III
- SQ4** Square Tube Class IV

RECEIVER HITCHES

RECEIVER HITCH APPLICATION GUIDE

MODEL / STYLE	YEAR	TRAILER HITCHES									
		PC	REC TYPE	REC SIZE	PART #	NO DRILL	FOOTNOTES	OPTIONAL DRAWBAR	WC (LBS.)	WD (LBS.)	IN
DODGE											
Avenger	08-10	28	SQ1	1-1/4	24871	0	GP, JR	3594	200/2,000		15
		31	SQ2	1-1/4	36448	0	GP, JR	36065	300/3,500		30
Avenger	11-11	28	SQ1	1-1/4	24871	0	GP, JR	3594	200/2,000		15
Avenger	12-14	28	SQ1	1-1/4	24871	0	GP, JR	3594	200/2,000		15
Caliber	07-07	23	SQ1	1-1/4	24769	0	GP	3591	200/2,000		15
Caliber Except SRT-4	08-12	23	SQ1	1-1/4	24769	0	GP	3591	200/2,000		15
Caravan	96-00	25	SQ1	1-1/4	24702	0	HM	3593	200/2,000		30
		23	SQ2	1-1/4	36296	0	GP	36071	300/3,500		30
		30	RT3	2	75119				350/3,500	500/5,000	30
		50	SQ3	2	37136				500/5,000	600/6,000	40
Caravan	01-03	25	SQ1	1-1/4	24702	0	HM	3593	200/2,000		30
		23	SQ2	1-1/4	36296	0	GP	36071	300/3,500		30
		30	RT3	2	75119	0			350/3,500	500/5,000	30
		50	SQ3	2	37136	0			500/5,000	600/6,000	40
Caravan Except w/Stow & Go Seats	04-07	25	SQ1	1-1/4	24702	0	HM	3593	200/2,000		30
		23	SQ2	1-1/4	36296	0	GP	36071	300/3,500		30
		30	RT3	2	75119	0			350/3,500	500/5,000	30
		50	SQ3	2	37136	0			500/5,000	600/6,000	40
Challenger Except Models w/Quad Tip Exhaust	08-14	27	SQ2	1-1/4	36548	0	HM	36061	300/3,500		30
Challenger Except Models w/Quad Tip Exhaust	15-16	27	SQ2	1-1/4	36548	0	HM	36061	300/3,500		30
Charger	06-10	27	SQ2	1-1/4	36548	0	HM	36061	300/3,500		30
Charger	11-14	27	SQ2	1-1/4	36548	0	HM	36061	300/3,500		30
Charger	15-16	27	SQ2	1-1/4	36548	0	HM	36061	300/3,500		30
Dakota	97-99	50	SQ3	2	37136		CT, GU		500/5,000	600/6,000	35
		34	SQ3	2	75038		GU		500/5,000	800/8,000	30
		31	SQ3	2	75073	0	GU		500/5,000	750/7,500	15
Dakota	00-01	50	SQ3	2	37136		CT, GU		500/5,000	600/6,000	35
		34	SQ3	2	75038		GU		500/5,000	800/8,000	30
		31	SQ3	2	75073	0	GU		500/5,000	750/7,500	15
Dakota w/Factory 7-Way	00-09										
Dakota	02-03	34	SQ3	2	75038		GU		500/5,000	800/8,000	30
		31	SQ3	2	75073	0	GU		500/5,000	750/7,500	15
Dakota Except Quad Cab	02-03	50	SQ3	2	37136		CT, GU		500/5,000	600/6,000	35
Dakota	04-04	34	SQ3	2	75038		GU		500/5,000	800/8,000	30
		31	SQ3	2	75073	0	GU		500/5,000	750/7,500	15
Dakota Except Quad Cab	04-04	50	SQ3	2	37136		CT, GU		500/5,000	600/6,000	35
Dakota	05-09	27	SQ3	2	75251	0	HM		500/5,000	800/8,000	20
Dakota	10-10	27	SQ3	2	75251	0	HM		500/5,000	800/8,000	20
Dart	13-16	30	SQ1	1-1/4	24890	0	HM	3592	200/2,000		20
Durango	98-99	34	SQ3	2	75081	0	GP		500/5,000	750/7,500	15
Durango	00-03	34	SQ3	2	75081	0	GP		500/5,000	750/7,500	15
Durango w/Factory 7-Way	00-08										
Durango	04-06	18	SQ4	2	75162	0	AI		600/6,000	900/9,000	50
		39	RT4	2	75292	0			600/6,000	900/9,000	20
Durango	07-08	18	SQ4	2	75162		AI		600/6,000	900/9,000	50
Durango	09-09	18	SQ4	2	75162		AI		600/6,000	900/9,000	50
Durango w/Factory 7-Way	09-09										
Durango	11-13	25	RT4	2	75713	0	CS, HM		600/6,000	750/7,500	20
Durango	14-17	25	RT4	2	75713	0	CS, HM		600/6,000	750/7,500	20
Grand Caravan	96-00	25	SQ1	1-1/4	24702	0	HM	3593	200/2,000		30
		23	SQ2	1-1/4	36296	0	GP	36071	300/3,500		30
		30	RT3	2	75119				350/3,500	500/5,000	30
		50	SQ3	2	37136				500/5,000	600/6,000	40

- AI Additional installation time may be required.
- CS Will fit with full-size spare tire stowed under vehicle.
- CT Will not fit long bed models after 1999.
- GP Hitch cross tube concealed behind bumper.
- GU Will not fit vehicles with factory or aftermarket lower Fascia/Rollpan or Tube Bumper.
- HM Hitch cross tube is visible beneath bumper.
- JR Exhaust must be temporarily lowered for installation.

RECEIVER HITCH APPLICATION GUIDE

D

DODGE

PC	T-ONE					TOW HARNESS					4-FLAT WIRING				REQ. 4 FLAT WIRING		7-WAY HARDWIRE	BRAKE CONTROL HARNESS	IN
	T-ONE	FN	IN	AMP	CP	TOW HARN	FN	IN	AMP	CP	TYPE	ELEC	POS	CHOICE 1	CHOICE 2	6-WAY ADAPTER			
DODGE																			
E19	118445	BN,CH	45	2.1,4.2	X							A,E	PC1,2	119148	119180				
E18	118550	BN,CH	45	2.1,5.6	X							B,E	PC1,2	119148	119180				
E17	118577	CH	45	2.1,5.6	X							N	PC1,2	119251					
E18	118428	BN,CH	45	2.1,4.2	X							B,E	PC1,2	119148	119180				
E18	118552	CH	45	4.2,7.5	X							A,E	PC1,2	119148	119180	20320	20321	20224	
E10	118334	HG	20	2.1,5								B	SUV1,2	119130	119178	20320	20321	20224	
E7	118376	HG	15	2.1,5								B	SUV1,2	119130	119178	20320	20321	20224	
E7	118300		20	7.5								A	SUV1,2	119180	20252	20320	20321	20224	
E7	118404		10	7.5								A	PC3,4	119180	20252				
E16	118656	CH	45	4.2,7.5	X							A,E	PC3,4	119148	119180				
E7	118404		10	7.5								A	PC3,4	119180	20252				
E19	118560	CH	25	4.2,7.5	X							N	PC3,4	119251					
E15	118655	CH	45	4.2,7.5	X							A,E	PC3,4	119148	119180				
E7	118329	BN,HJ	5	7.5								A	PU3,4	119180	20252	20320	20321	20224	3020-P 5
E7	118329	BN,HJ	5	7.5		E3	118381	BN,RD	5	7.5	4-Flat	A	PU3,4	119180	20252	20320	20321	20224	3020-P 5
E7	118329	BN,HJ	5	7.5			20135	RD	10		Both	A	PU3	119180	20252				
E7	118329	BN,HJ	5	7.5		E3	118381	BN,RD	5	7.5	4-Flat	A	PU3,4	119180	20252	20320	20321	20224	3020-P 5
E7	118329	BN,HJ	5	7.5		E3	118381	BN,RD	5	7.5	4-Flat	A	PU3,4	119180	20252	20320	20321	20224	3020-P 5
E6	118323	BN,HJ	10	7.5		E3	118381	BN,RD	5	7.5	4-Flat	A	PU1,2	119180	20252	20320	20321	20224	3020-P 5
E6	118323	BN,HJ	10	7.5		E3	118381	BN,RD	5	7.5	4-Flat	A	PU1,2	119180	20252	20320	20321	20224	3020-P 5
E6	118323	BN,HJ	10	7.5		E3	118381	BN,RD	5	7.5	4-Flat	A	PU1,2	119180	20252	20320	20321	20224	3020-P 5
E6	118323	BN,HJ	10	7.5		E3	118381	BN,RD	5	7.5	4-Flat	A	PU1,2	119180	20252	20320	20321	20224	3020-P 5
E16	118568		25	4.2,7.5	X							A,E	PC3,4	119148	119180				
E10	118334	BN,HG	20	2.1,5								B	SUV1,2	119130	119178	20320	20321	20224	3020-P 5
E10	118334	BN,HG	20	2.1,5		E3	118381	BN,RD	5	7.5	4-Flat	B	SUV1,2	119130	119178	20320	20321	20224	3020-P 5
							20135	RD	10		Both	H	SUV6	119180	20252				
E15	118390	BN,CH	45	2.1,5.6	X	E3	118381	BN,RD	5	7.5	4-Flat	B,E	SUV1,2	119148	119180	20320	20321	20224	3020-P 5
E15	118390	BN,CH	45	2.1,5.6	X	E3	118381	BN,RD	5	7.5	4-Flat	B,E	SUV1,2	119148	119180	20320	20321	20224	3020-P 5
E15	118390	BN,CH	45	2.1,5.6	X	E8	118384	BN,RD	5	7.5	4-Flat	B,E	SUV1,2	119148	119180	20320	20321	20224	3020-P 5
							20119	RD	10		Both	H	SUV6	119180	20252				
E18	118552	CH	45	4.2,7.5	X							A,E	SUV1,2	119148	119180	20320	20321	20224	3045-P 5
E16	118617	CH,BN	45	4.2,7.5	X							A,E	SUV1,2	119148	119180	20320	20321	20224	3045-P 5
E10	118334	HG	20	2.1,5								B	SUV1,2	119130	119178	20320	20321	20224	

- A** 2 wire system.
- B** 3 wire system. Converter required.
- BN** Exterior mounted plug on some or all models. May require an aftermarket electrical mounting box or bracket. (Sold separately)
- CH** T-One is equipped with circuit protected Modulite® module.
- E** Modulite® required.

- H** 3 wire system with OEM standard 2 wire harness.
- HG** T-One incorporates taillight converter.
- HJ** Per Dodge owner's manual: If trailer is equipped with more than standard lighting (1 taillight per side) use of Modulite® or dealer supplied harness is required.
- N** DO NOT cut or splice vehicle wiring. Only use approved T-One or see auto dealer for trailer tow wiring kit.
- RD** For vehicles equipped with factory tow package may require additional components or may be used as a replacement harness.

- RT3** Round Tube Class III 2"
- RT4** Round Tube Class IV 2"
- SQ1** Square Tube Class I
- SQ2** Square Tube Class II
- SQ3** Square Tube Class III
- SQ4** Square Tube Class IV

RECEIVER HITCHES

RECEIVER HITCH APPLICATION GUIDE

MODEL / STYLE	YEAR	TRAILER HITCHES									
		PC	REC TYPE	REC SIZE	PART #	NO DRILL	FOOTNOTES	OPTIONAL DRAWBAR	WC (LBS.)	WD (LBS.)	IN
DODGE (Continued)											
Grand Caravan	01-03	25	SQ1	1-1/4	24702	0	HM	3593 36071	200/2,000		30
		23	SQ2	1-1/4	36296	0	GP		300/3,500		30
		30	RT3	2	75119	0			350/3,500	500/5,000	30
		50	SQ3	2	37136				500/5,000	600/6,000	40
Grand Caravan Except w/Stow & Go Seats	04-07	25	SQ1	1-1/4	24702	0	HM	3593 36071	200/2,000		30
		23	SQ2	1-1/4	36296	0	GP		300/3,500		30
		30	RT3	2	75119	0			350/3,500	500/5,000	30
		50	SQ3	2	37136				500/5,000	600/6,000	40
Grand Caravan w/Stow & Go Seats	05-07	45	SQ2	1-1/4	36320	0	HM	36071	300/3,500		25
		54	SQ3	2	75305	0			350/3,500	400/4,000	25
Grand Caravan	08-10	24	SQ2	1-1/4	36455	0	GP, JR	36061	300/3,500		20
		21	SQ3	2	75579	0	GP, JR		400/4,000	500/5,000	20
Grand Caravan	11-17	24	SQ2	1-1/4	36455	0	GP, JR	36061	300/3,500		20
		21	SQ3	2	75579	0	GP, JR		400/4,000	500/5,000	20
Intrepid	93-97	43	SQ2	1-1/4	36170		JR,TA,HM	36061	300/3,500		40
Intrepid	98-04	37	SQ2	1-1/4	36268		JR,HM	36053	300/3,500		30
Journey	09-09	29	RT3	2	75648	0	HM, JR		400/4,000	400/4,000	25
Journey	10-10	29	RT3	2	75648	0	HM, JR		400/4,000	400/4,000	25
Journey w/LED Taillights	11-16	29	RT3	2	75648	0	HM, JR		400/4,000	400/4,000	25
Journey Except w/LED Taillights	12-16	29	RT3	2	75648	0	HM, JR		400/4,000	400/4,000	25
Magnum	05-08	27	SQ2	1-1/4	36548	0	HM	36061	300/3,500		30
Neon	00-05	42	SQ1	1-1/4	24701		GP, JR	3593	200/2,000		20
Nitro	07-07	29	SQ3	2	75517	0	GP		500/5,000	600/6,000	20
Nitro	08-11	29	SQ3	2	75517	0	GP		500/5,000	600/6,000	20
Ram w/Factory 7-Way	00-01										
Ram 1500	95-01	49	RT3	2	37133		GU		500/5,000	750/7,500	40
		25	SQ3	2	75101	0			500/5,000	800/8,000	15
		30	SQ4	2	40050		CQ,GO,GX		600/6,000	1,000/10,000	40
		56	SQ4	2	41536	0			600/6,000	1,000/10,000	15
		54	RT4	2	37130		GU		700/7,000	1,200/12,000	40
		45	SQ5	2	41923	0	@,GP		1,200/12,000	1,400/14,000	35
Ram 1500 w/Deep Drop Bumper	95-01	29	SQ3	2	41504		CQ		500/5,000	1,000/10,000	40
Ram 1500 (Built Before 11/2002)	02-03	14	SQ3	2	75135	0	CP,DS,GU		500/5,000	1,000/10,000	15
Ram 1500 (Built Before 11/2002), w/Factory 7-Way	02-03										
Ram 1500 (Built After 11/2002)	03-03	11	SQ3	2	75151	0	CP,DS,GU		500/5,000	800/8,000	20
		46	SQ4	2	75420	0	CP,DY		600/6,000	1,000/10,000	25
		11	SQ4	2	75662	0	CP,DS		600/6,000	1,000/10,000	20
		37	SQ5	2	41929		@,DY,GP,KL,SG		1,200/12,000	1,500/15,000	35
		64	SQ5	2-1/2	45518		#,DY,KL,SB		1,200/12,000	1,700/14,000	35
Ram 1500 (Built After 11/2002) w/Factory 7-Way	03-03										
Ram 1500 Except Daytona/Hemi Sport Quad Cab/Ram Rumble Bee/SRT-10	04-05	11	SQ3	2	75151	0	CP,GU		500/5,000	800/8,000	20
		46	SQ4	2	75420	0	CP		600/6,000	1,000/10,000	25
		11	SQ4	2	75662	0	CP		600/6,000	1,000/10,000	20
		37	SQ5	2	41929		@,GP,KL,SG		1,200/12,000	1,500/15,000	35
		64	SQ5	2-1/2	45518		#,KL,SB		1,200/12,000	1,700/14,000	35
Ram 1500 Except Daytona/Hemi Sport Quad Cab/Ram Rumble Bee/SRT-10, w/Factory 7-Way	04-05										
Ram 1500	06-08	11	SQ3	2	75151	0	CP,GU		500/5,000	800/8,000	20
		46	SQ4	2	75420	0	CP		600/6,000	1,000/10,000	25
		11	SQ4	2	75662	0	CP		600/6,000	1,000/10,000	20
		37	SQ5	2	41929		@,GP,KL,SG		1,200/12,000	1,500/15,000	35
		64	SQ5	2-1/2	45518		#,KL,SB		1,200/12,000	1,700/14,000	35
Ram 1500 Except Mega Cab/SRT-10, w/Factory 7-Way	06-08										

- # Titan hitches require use of a 2-1/2" shank Titan ball mount.
- @ Ultra Frame ball mount must be used to achieve maximum weight carrying rating.
- CP Fits all models without factory installed receiver.
- CQ Will not fit with heavy duty suspension.
- DS Use DT #75151 On 1500 Models Built After 11/1/02. Use DT #75135 On 1500 Models Built Before 11/1/02.
- DY Use On 1500 Models Built After 11/1/02.
- GO Requires hitch with packaging date code 2/15/94 or later.
- GP Hitch crosstube concealed behind bumper.
- GU Will not fit vehicles with factory or aftermarket lower Fascia/Rollpan or Tube Bumper.
- GX Requires fabrication of "L" bracket to reposition exhaust on '95 and later 6 ft. box models.
- HM Hitch crosstube is visible beneath bumper.
- JR Exhaust must be temporarily lowered for installation.
- KL Hitch is designed to attach beneath the OEM hitch.
- SB Will not fit models with short bed.
- SG Hitches produced before 09/10/07 are rated at 1000/10000 WC & 1200/12000 WD.
- TA Trunk access required for hitch installation.

RECEIVER HITCH APPLICATION GUIDE

D

DODGE

PC	T-ONE					TOW HARNESS						4-FLAT WIRING				REQ. 4 FLAT WIRING		7-WAY HARDWIRE	BRAKE CONTROL HARNESS	IN	
	T-ONE	FN	IN	AMP	CP	PC	TOW HARN	FN	IN	AMP	CP	TYPE	ELEC	POS	CHOICE 1	CHOICE 2	6-WAY ADAPTER				7-WAY ADAPTER
DODGE (Continued)																					
E7	118376	HG	15	2.1,5									B	SUV1,2	119130	119178	20320	20321	20224		
E7	118300		20	7.5									A	SUV1,2	119180	20252	20320	20321	20224		
E7	118300		20	7.5									A	SUV1,2	119180	20252	20320	20321	20224		
E18	118552	CH	45	4.2,7.5	X								A,E	SUV1,2	119148	119180	20320	20321	20224		
E18	118534	BN,CH	45	4.2,7.5	X								G,E	SUV1,2	119180	119148	20320	20321	20224		
													B	PC3,4	119130	119178					
E12	118364	BN,HG	15	2.1,5									B	PC1,2	119130	119178					
E18	118474	CH	45	2.1,5,6	X								B,E	SUV1,2	119148	119180	20320	20321	20224		
E8	118495		10	7.5									A	SUV1,2	119180	20252	20320	20321	20224		
E17	118536	CH	45	4.2,7.5	X								BM	SUV1,2	119251	119191	20320	20321	20224		
E14	118567	CH	45	2.1,5,6	X								A,E	SUV1,2	119148	119180	20320	20321	20224		
E19	118402	BN,CH	45	2.1,5,6	X								B,E	PC1,2	119148	119180					
													A	PC3,4	119180	20252					
E19	118554	BN,CH	45	4.2,7.5	X								B	SUV1,2	119130	119178	20320	20321	20224		
E19	118554	BN,CH	45	4.2,7.5	X								B,E	SUV1,2	119148	119180	20320	20321	20224		
							20135	RD	10				Both	H	PU3	119180	20252				
E7	118329	BN,HJ	5	7.5									A	PU3,4	119180	20252	20320	20321	20224	3020-P	5
E7	118329	BN,HJ	5	7.5									A	PU3,4	119180	20252	20320	20321	20224	3020-P	5
						E3	118381	BN,RD	5	7.5		4-Flat	A	PU3	119180	20252	20320	20321	20224	3020-P	5
							20135	RD	10			Both	H	PU3	119180	20252					
						E3	118381	BN,RD	5	7.5		4-Flat	A	PU3	119180	20252	20320	20321	20224	3020-P	5
							20135	RD	10			Both	H	PU3	119180	20252					
						E3	118381	BN,RD	5	7.5		4-Flat	A	PU3	119180	20252	20320	20321	20224	3020-P	5
							20135	RD	10			Both	H	PU3	119180	20252					
						E3	118381	BN,RD	5	7.5		4-Flat	A	PU3	119180	20252	20320	20321	20224	3020-P	5
							20135	RD	10			Both	H	PU3	119180	20252					

- A** 2 wire system.
- B** 3 wire system. Converter required.
- BM** Multiplexed wiring system. ModuLite® HD Plus or Ultra required.
- BN** Exterior mounted plug on some or all models. May require an aftermarket electrical mounting box or bracket. (Sold separately)
- C** 2 or 3 wire system determine at installation.
- CH** T-One is equipped with circuit protected ModuLite® module.

- E** ModuLite® required.
- H** 3 wire system with OEM standard 2 wire harness.
- HG** T-One incorporates taillight converter.
- HJ** Per Dodge owner's manual: If trailer is equipped with more than standard lighting (1 taillight per side) use of ModuLite® or dealer supplied harness is required.
- RD** For vehicles equipped with factory tow package may require additional components or may be used as a replacement harness.

- RT3** Round Tube Class III 2"
- RT4** Round Tube Class IV 2"
- SQ1** Square Tube Class I
- SQ2** Square Tube Class II
- SQ3** Square Tube Class III
- SQ4** Square Tube Class IV
- SQ5** Square Tube Class V

RECEIVER HITCHES

RECEIVER HITCH APPLICATION GUIDE

MODEL / STYLE	YEAR	TRAILER HITCHES									
		PC	REC TYPE	REC SIZE	PART #	NO DRILL	FOOTNOTES	OPTIONAL DRAWBAR	WC (LBS.)	WD (LBS.)	IN
DODGE (Continued)											
Ram 1500	09-09	11	SQ4	2	75662	0	CP		600/6,000	1,000/10,000	20
Ram 1500 w/Factory 7-Way	09-10										
Ram 1500	10-10	11	SQ4	2	75662	0	CP		600/6,000	1,000/10,000	20
Ram 2500	95-98	50	SQ5	2-1/2	45505		#,HX		1,200/12,000	1,700/14,000	45
Ram 2500	95-02	49	RT3	2	37133		GU		500/5,000	750/7,500	40
		25	SQ3	2	75101	0			500/5,000	800/8,000	15
		30	SQ4	2	40050		CQ,GO,GX		600/6,000	1,000/10,000	40
		56	SQ4	2	41536	0			600/6,000	1,000/10,000	15
		54	RT4	2	37130		GU		700/7,000	1,200/12,000	40
	45	SQ5	2	41923	0	@,GP		1,200/12,000	1,400/14,000	35	
Ram 2500 w/Deep Drop Bumper	95-02	29	SQ3	2	41504		CQ		500/5,000	1,000/10,000	40
Ram 2500	99-02	54	SQ5	2-1/2	45513		#		1,200/12,000	1,700/14,000	30
Ram 2500 w/Factory 7-Way	02-09										
Ram 2500	03-05	11	SQ3	2	75151	0	CP,GU		500/5,000	800/8,000	20
		46	SQ4	2	75420	0	CP,DY		600/6,000	1,000/10,000	25
		11	SQ4	2	75662	0	CP		600/6,000	1,000/10,000	20
		37	SQ5	2	41929		@,GP,KL,SG		1,200/12,000	1,500/15,000	35
		64	SQ5	2-1/2	45518		#,KL,SB		1,200/12,000	1,700/14,000	35
		66	SQ5	2-1/2	45509		#,AA,GH,HM,LT,SO,TO		2,000/18,000	2,500/18,000	95
Ram 2500	06-09	11	SQ3	2	75151	0	CP,GU		500/5,000	800/8,000	20
		46	SQ4	2	75420	0	CP		600/6,000	1,000/10,000	25
		11	SQ4	2	75662	0	CP		600/6,000	1,000/10,000	20
		37	SQ5	2	41929		@,GP,KL,SG		1,200/12,000	1,500/15,000	35
		66	SQ5	2-1/2	45509		#,AA,GH,HM,LT,SO,TO		2,000/18,000	2,500/18,000	95
Ram 2500 Except Mega Cab	06-09	64	SQ5	2-1/2	45518		#,KL,SB		1,200/12,000	1,700/14,000	35
Ram 2500	10-10	37	SQ5	2	41929		@,GP,KL,SG		1,200/12,000	1,500/15,000	35
		66	SQ5	2-1/2	45509		#,AA,GH,HM,LT,SO,TO		2,000/18,000	2,500/18,000	95
Ram 2500 Except Mega Cab	10-10	64	SQ5	2-1/2	45518		#,KL,SB		1,200/12,000	1,700/14,000	35
Ram 2500 w/Factory 7-Way	10-10										
Ram 3500	95-98	50	SQ5	2-1/2	45505		#,HX		1,200/12,000	1,700/14,000	45
Ram 3500	95-02	49	RT3	2	37133		GU		500/5,000	750/7,500	40
		25	SQ3	2	75101	0			500/5,000	800/8,000	15
		30	SQ4	2	40050		CQ,GO,GX		600/6,000	1,000/10,000	40
		56	SQ4	2	41536	0			600/6,000	1,000/10,000	15
		54	RT4	2	37130		GU		700/7,000	1,200/12,000	40
		45	SQ5	2	41923	0	@,GP		1,200/12,000	1,400/14,000	35
		29	SQ3	2	41504		CQ		500/5,000	1,000/10,000	40
Ram 3500 w/Deep Drop Bumper	95-02	29	SQ3	2	41504		CQ		500/5,000	1,000/10,000	40
Ram 3500	99-02	54	SQ5	2-1/2	45513		#		1,200/12,000	1,700/14,000	30
Ram 3500 w/Factory 7-Way	02-09										
Ram 3500	03-05	11	SQ3	2	75151	0	CP,GU		500/5,000	800/8,000	20
		46	SQ4	2	75420	0	CP,DY		600/6,000	1,000/10,000	25
		11	SQ4	2	75662	0	CP		600/6,000	1,000/10,000	20
		37	SQ5	2	41929		@,GP,KL,SG		1,200/12,000	1,500/15,000	35
		64	SQ5	2-1/2	45518		#,KL,SB		1,200/12,000	1,700/14,000	35
		66	SQ5	2-1/2	45509		#,AA,GH,HM,LT,SO,TO		2,000/18,000	2,500/18,000	95
Ram 3500	06-09	11	SQ3	2	75151	0	CP,GU		500/5,000	800/8,000	20
		46	SQ4	2	75420	0	CP		600/6,000	1,000/10,000	25
		11	SQ4	2	75662	0	CP		600/6,000	1,000/10,000	20
		37	SQ5	2	41929		@,GP,KL,SG		1,200/12,000	1,500/15,000	35
		66	SQ5	2-1/2	45509		#,AA,GH,HM,LT,SO,TO		2,000/18,000	2,500/18,000	95
Ram 3500 Except Mega Cab	06-09	64	SQ5	2-1/2	45518		#,KL,SB		1,200/12,000	1,700/14,000	35

- # Titan hitches require use of a 2-1/2" shank Titan ball mount.
- @ Ultra Frame ball mount must be used to achieve maximum weight carrying rating.
- AA Requires temporary removal of bumper during installation.
- CP Fits all models without factory installed receiver.
- CQ Will not fit with heavy duty suspension.
- DY Use On 1500 Models Built After 11/1/02.
- GH Will not fit models with 34" wide frames.
- GO Requires hitch with packaging date code 2/15/94 or later.
- GP Hitch crosstube concealed behind bumper.
- GU Will not fit vehicles with factory or aftermarket lower Fascia/Rollpan or Tube Bumper.
- GX Requires fabrication of "L" bracket to reposition exhaust on '95 and later 6 ft. box models.
- HM Hitch crosstube is visible beneath bumper.
- HX Minor exhaust modification may be required.
- KL Hitch is designed to attach beneath the OEM hitch.
- LT Requires removal of factory hitch if equipped.
- SB Will not fit models with short bed.
- SG Hitches produced before 09/10/07 are rated at 1000/10000 WC & 1200/12000 WD.
- SO With this hitch installed the step bumper is no longer able to be used as a towing point.
- TO Will not fit models equipped Chassis Cab spring mount.

RECEIVER HITCH APPLICATION GUIDE

D

DODGE

T-ONE						TOW HARNESS						4-FLAT WIRING				REQ. 4 FLAT WIRING		7-WAY HARDWIRE	BRAKE CONTROL HARNESS	IN	
PC	T-ONE	FN	IN	AMP	CP	PC	TOW HARN	FN	IN	AMP	CP	TYPE	ELEC	POS	CHOICE 1	CHOICE 2	6-WAY ADAPTER				7-WAY ADAPTER
DODGE (Continued)																					
						E8	118384	BN,RD	5	7.5		4-Flat	A	PU3	119180	20252	20320	20321	20224	3020-P	5
							20119	RD	10			Both	A	PU3	119180	20252					
							118015	RD	10			7-Way									
						E8	118384	BN,RD	5	7.5		4-Flat	A	PU3	119180	20252	20320	20321	20224	3021-P	5
E7	118329	BN,HJ	5	7.5									A	PU3,4	119180	20252	20320	20321	20224	3020-P	5
E7	118329	BN,HJ	5	7.5									A	PU3,4	119180	20252	20320	20321	20224	3020-P	5
E7	118329	BN,HJ	5	7.5									A	PU3,4	119180	20252	20320	20321	20224	3020-P	5
E7	118329	BN,HJ	5	7.5									A	PU3,4	119180	20252	20320	20321	20224	3020-P	5
							20135	RD	10			Both	H	PU3	119180	20252					
						E3	118381	BN,RD	5	7.5		4-Flat	A	PU3	119180	20252	20320	20321	20224	3020-P	5
						E3	118381	BN,RD	5	7.5		4-Flat	A	PU3	119180	20252	20320	20321	20224	3020-P	5
						E3	118381	BN,RD	5	7.5		4-Flat	A	PU3	119180	20252	20320	20321	20224	3020-P	5
						E8	118384	BN,RD	5	7.5		4-Flat	A	PU3	119180	20252	20320	20321	20224	3021-P	5
						E8	118384	BN,RD	5	7.5		4-Flat	A	PU3	119180	20252	20320	20321	20224	3021-P	5
						E8	118384	BN,RD	5	7.5		4-Flat	A	PU3	119180	20252	20320	20321	20224	3021-P	5
							20119	RD	10			Both	A	PU3	119180	20252					
							118015	RD	10			7-Way									
E7	118329	BN,HJ	5	7.5									A	PU3,4	119180	20252	20320	20321	20224	3020-P	5
E7	118329	BN,HJ	5	7.5									A	PU3,4	119180	20252	20320	20321	20224	3020-P	5
E7	118329	BN,HJ	5	7.5									A	PU3,4	119180	20252	20320	20321	20224	3020-P	5
E7	118329	BN,HJ	5	7.5									A	PU3,4	119180	20252	20320	20321	20224	3020-P	5
							20135	RD	10			Both	H	PU3	119180	20252					
						E3	118381	BN,RD	5	7.5		4-Flat	A	PU3	119180	20252	20320	20321	20224	3020-P	5
						E3	118381	BN,RD	5	7.5		4-Flat	A	PU3	119180	20252	20320	20321	20224	3020-P	5
						E3	118381	BN,RD	5	7.5		4-Flat	A	PU3	119180	20252	20320	20321	20224	3020-P	5

- A** 2 wire system.
- BN** Exterior mounted plug on some or all models. May require an aftermarket electrical mounting box or bracket. (Sold separately)
- H** 3 wire system with OEM standard 2 wire harness.

- HJ** Per Dodge owner's manual: If trailer is equipped with more than standard lighting (1 taillight per side) use of ModuLite® or dealer supplied harness is required.
- RD** For vehicles equipped with factory tow package may require additional components or may be used as a replacement harness.

- RT3** Round Tube Class III 2"
- RT4** Round Tube Class IV 2"
- SQ3** Square Tube Class III
- SQ4** Square Tube Class IV
- SQ5** Square Tube Class V

RECEIVER HITCHES

RECEIVER HITCH APPLICATION GUIDE

MODEL / STYLE	YEAR	TRAILER HITCHES									
		PC	REC TYPE	REC SIZE	PART #	NO DRILL	FOOTNOTES	OPTIONAL DRAWBAR	WC (LBS.)	WD (LBS.)	IN
DODGE (Continued)											
Ram 3500 Cab & Chassis, w/34" Wide Frames	07-10	29 50	SQ5 SQ5	2 2	41936 41947		@ @		1,200/12,000 1,600/15,000		30 35
Ram 3500	10-10	37 66	SQ5 SQ5	2 2-1/2	41929 45509		@,GP,KL,SG #,AA,GH,HM,LT,SO,TO		1,200/12,000 2,000/18,000	1,500/15,000 2,500/18,000	35 95
Ram 3500 Except Mega Cab	10-10	64	SQ5	2-1/2	45518		#,KL,SB		1,200/12,000	1,700/14,000	35
Ram 3500 w/Factory 7-Way	10-10										
Ram 4500 Cab & Chassis, w/34" Wide Frames	08-10	29 50	SQ5 SQ5	2 2	41936 41947		@ @		1,200/12,000 1,600/15,000	1,600/16,000	30 35
Ram 5500 Cab & Chassis, w/34" Wide Frames	08-10	29 50	SQ5 SQ5	2 2	41936 41947		@ @		1,200/12,000 1,600/15,000	1,600/16,000	30 35
Sprinter 2500 w/41" Wide Frames, Except 118" Wheelbase & Factory Metal Step Platform	03-06	48	SQ3	2	75210	0	HM		500/5,000	750/7,500	20
Sprinter 2500 w/41" Wide Frames, Except 118" Wheelbase & Factory Metal Step Platform, w/Factory 7-Way	03-06										
Sprinter 2500 144" & 170" Wheelbase, Except w/Factory Step Bumper	07-09	53	SQ4	2	75549	0	HM,UL		600/6,000	750/7,500	20
Sprinter 2500 144" & 170" Wheelbase, Except w/Factory Step Bumper, w/Factory 7-Way	07-09										
Sprinter 2500 w/Factory Step Bumper Excluding Models w/30-3/8" Frame Width	07-09	52	SQ3	2	75601	0	HM		500/5,000	750/7,500	30
Sprinter 2500 w/Factory Step Bumper, w/Factory 7-Way	07-09										
Sprinter 3500 w/41" Wide Frames, Except 118" Wheelbase & Factory Metal Step Platform	03-06	48	SQ3	2	75210	0	HM		500/5,000	750/7,500	20
Sprinter 3500 w/41" Wide Frames, Except 118" Wheelbase & Factory Metal Step Platform, w/Factory 7-Way	03-06										
Sprinter 3500 144" & 170" Wheelbase, Except w/Factory Step Bumper	07-09	53	SQ4	2	75549	0	HM,UL		600/6,000	750/7,500	20
Sprinter 3500 144" & 170" Wheelbase, Except w/Factory Step Bumper, w/Factory 7-Way	07-09										
Sprinter 3500 w/Factory Step Bumper Excluding Models w/30-3/8" Frame Width	07-09	52	SQ3	2	75601	0	HM		500/5,000	750/7,500	30
Sprinter 3500 w/Factory Step Bumper, w/Factory 7-Way	07-09										
Stratus 4 Dr.	95-06	40	SQ2	1-1/4	36301		JR,HM	36061	300/3,500		60
Van, B1500	95-97	41 30 37 63	SQ3 SQ3 SQ4 SQ5	2 2 2 2	75090 75140 41533 41910	0 0 0 0	DH DH DH @,DH,HM		500/5,000 500/5,000 600/6,000 1,000/10,000	750/7,500 1,000/10,000 1,000/10,000 1,200/12,000	20 30 20 35
Van, B1500	98-98	41 30 37 63	SQ3 SQ3 SQ4 SQ5	2 2 2 2	75090 75140 41533 41910	0 0 0 0	BF BF BF @,HM		500/5,000 500/5,000 600/6,000 1,000/10,000	750/7,500 1,000/10,000 1,000/10,000 1,200/12,000	20 30 20 35
Van, B2500	95-97	41 30 37 63	SQ3 SQ3 SQ4 SQ5	2 2 2 2	75090 75140 41533 41910	0 0 0 0	DH DH DH @,DH,HM		500/5,000 500/5,000 600/6,000 1,000/10,000	750/7,500 1,000/10,000 1,000/10,000 1,200/12,000	20 30 20 35
Van, B2500	98-98	41 30 37 63	SQ3 SQ3 SQ4 SQ5	2 2 2 2	75090 75140 41533 41910	0 0 0 0	BF BF BF @,HM		500/5,000 500/5,000 600/6,000 1,000/10,000	750/7,500 1,000/10,000 1,000/10,000 1,200/12,000	20 30 20 35

- | | |
|---|--|
| # Titan hitches require use of a 2-1/2" shank Titan ball mount. | JR Exhaust must be temporarily lowered for installation. |
| @ Ultra Frame ball mount must be used to achieve maximum weight carrying rating. | KL Hitch is designed to attach beneath the OEM hitch. |
| AA Requires temporary removal of bumper during installation. | LT Requires removal of factory hitch if equipped. |
| BF Requires standard bumper. Will not fit with step bumper. | SB Will not fit models with short bed. |
| DH Cannot be installed on 1987-97 vehicles with factory step bumpers unless step bumper and its mounting brackets are permanently removed and standard factory bumper is installed. | SG Hitches produced before 09/10/07 are rated at 1000/10000 WC & 1200/12000 WD. |
| GH Will not fit models with 34" wide frames. | SO With this hitch installed the step bumper is no longer able to be used as a towing point. |
| GP Hitch crosstube concealed behind bumper. | TO Will not fit models equipped Chassis Cab spring mount. |
| HM Hitch crosstube is visible beneath bumper. | UL This hitch will not fit a Sprinter single or dual rear-wheel vehicle with a 30-3/8" wide frame measured outside of frame to outside of frame. |

RECEIVER HITCH APPLICATION GUIDE

D

DODGE

T-ONE						TOW HARNESS						4-FLAT WIRING				REQ. 4 FLAT WIRING		BRAKE CONTROL HARNESS	IN		
PC	T-ONE	FN	IN	AMP	CP	PC	TOW HARN	FN	IN	AMP	CP	TYPE	ELEC	POS	CHOICE 1	CHOICE 2	6-WAY ADAPTER			7-WAY ADAPTER	7-WAY HARDWIRE
DODGE (Continued)																					
													C	PU1,2	119180	119148	20320	20321	20224	3020-P	5
						E8	118384	BN,RD	5	7.5		4-Flat	A	PU3	119180	20252	20320	20321	20224	3021-P	5
						E8	118384	BN,RD	5	7.5		4-Flat	A	PU3	119180	20252	20320	20321	20224	3021-P	5
							20119 118015	RD RD	10 10			Both 7-Way	A	PU3	119180	20252					
													C	PU1,2	119180	119148	20320	20321	20224	3020-P	5
													C	PU1,2	119180	119148	20320	20321	20224	3020-P	5
						E3	118381	BN,RD	5	7.5		4-Flat	B,E	SUV3,4	119148	119180	20320	20321	20224		
							20135	RD	10			Both	H	SUV6							
E17	118650	CH	45	5,7.5	X	E3	118381	BN,RD	5	7.5		4-Flat	B,E	SUV1,2	119148	119180	20320	20321	20224		
							20135	RD	10			Both	H	SUV6	119180	20252					
E17	118650	CH	45	5,7.5	X	E3	118381	BN,RD	5	7.5		4-Flat	B,E	SUV1,2	119148	119180	20320	20321	20224		
							20135	RD	10			Both	H	SUV6	119180	20252					
						E3	118381	BN,RD	5	7.5		4-Flat	B,E	SUV3,4	119148	119180	20320	20321	20224		
							20135	RD	10			Both	H	SUV6	119180	20252					
E17	118650	CH	45	5,7.5	X	E3	118381	BN,RD	5	7.5		4-Flat	B,E	SUV1,2	119148	119180	20320	20321	20224		
							20135	RD	10			Both	H	SUV6	119180	20252					
E17	118650	CH	45	5,7.5	X	E3	118381	BN,RD	5	7.5		4-Flat	B,E	SUV1,2	119148	119180	20320	20321	20224		
							20135	RD	10			Both	H	SUV6	119180	20252					
													B	PC3,4	119130	119178					
E1	118328	BN	5	7.5									A	SUV7	119180	20252	20320	20321	20224		
E1	118328	BN	5	7.5									A	SUV7	119180	20252	20320	20321	20224		
E1	118328	BN	5	7.5									A	SUV7	119180	20252	20320	20321	20224		
E1	118328	BN	5	7.5									A	SUV7	119180	20252	20320	20321	20224		

A 2 wire system.
B 3 wire system. Converter required.
BN Exterior mounted plug on some or all models. May require an aftermarket electrical mounting box or bracket. (Sold separately)
C 2 or 3 wire system determine at installation.

CH T-One is equipped with circuit protected Modulite® module.
E Modulite® required.
H 3 wire system with OEM standard 2 wire harness.
RD For vehicles equipped with factory tow package may require additional components or may be used as a replacement harness.

SQ2 Square Tube Class II
SQ3 Square Tube Class III
SQ4 Square Tube Class IV
SQ5 Square Tube Class V

RECEIVER HITCHES

RECEIVER HITCH APPLICATION GUIDE

MODEL / STYLE	YEAR	TRAILER HITCHES									
		PC	REC TYPE	REC SIZE	PART #	NO DRILL	FOOTNOTES	OPTIONAL DRAWBAR	WC (LBS.)	WD (LBS.)	IN
DODGE (Continued)											
Van, B3500	95-97	41	SQ3	2	75090	0	DH		500/5,000	750/7,500	20
		30	SQ3	2	75140	0	DH		500/5,000	1,000/10,000	30
		37	SQ4	2	41533	0	DH		600/6,000	1,000/10,000	20
		63	SQ5	2	41910	0	@,DH,HM		1,000/10,000	1,200/12,000	35
Van, B3500	98-98	41	SQ3	2	75090	0	BF		500/5,000	750/7,500	20
		30	SQ3	2	75140	0			500/5,000	1,000/10,000	30
		37	SQ4	2	41533	0	BF		600/6,000	1,000/10,000	20
		63	SQ5	2	41910	0	@,HM		1,000/10,000	1,200/12,000	35
Van, Ram 1500	99-00	41	SQ3	2	75090	0	BF		500/5,000	750/7,500	20
		30	SQ3	2	75140	0			500/5,000	1,000/10,000	30
		37	SQ4	2	41533	0	BF		600/6,000	1,000/10,000	20
		63	SQ5	2	41910	0	@,HM		1,000/10,000	1,200/12,000	35
Van, Ram 1500	01-03	41	SQ3	2	75090	0	BF		500/5,000	750/7,500	20
		30	SQ3	2	75140	0			500/5,000	1,000/10,000	30
		37	SQ4	2	41533	0	BF		600/6,000	1,000/10,000	20
Van, Ram 1500 Except w/109.3" Wheelbase	01-03	63	SQ5	2	41910	0	@,HM		1,000/10,000	1,200/12,000	35
Van, Ram 1500 w/Factory 7-Way	01-03										
Van, Ram 2500	99-00	41	SQ3	2	75090	0	BF		500/5,000	750/7,500	20
		30	SQ3	2	75140	0			500/5,000	1,000/10,000	30
		37	SQ4	2	41533	0	BF		600/6,000	1,000/10,000	20
		63	SQ5	2	41910	0	@,HM		1,000/10,000	1,200/12,000	35
Van, Ram 2500	01-03	41	SQ3	2	75090	0	BF		500/5,000	750/7,500	20
		30	SQ3	2	75140	0			500/5,000	1,000/10,000	30
		37	SQ4	2	41533	0	BF		600/6,000	1,000/10,000	20
Van, Ram 2500 Except w/109.3" Wheelbase	01-03	63	SQ5	2	41910	0	@,HM		1,000/10,000	1,200/12,000	35
Van, Ram 2500 w/Factory 7-Way	01-03										
Van, Ram 3500	99-00	41	SQ3	2	75090	0	BF		500/5,000	750/7,500	20
		30	SQ3	2	75140	0			500/5,000	1,000/10,000	30
		37	SQ4	2	41533	0	BF		600/6,000	1,000/10,000	20
		63	SQ5	2	41910	0	@,HM		1,000/10,000	1,200/12,000	35
Van, Ram 3500	01-03	41	SQ3	2	75090	0	BF		500/5,000	750/7,500	20
		30	SQ3	2	75140	0			500/5,000	1,000/10,000	30
		37	SQ4	2	41533	0	BF		600/6,000	1,000/10,000	20
Van, Ram 3500 Except w/109.3" Wheelbase	01-03	63	SQ5	2	41910	0	@,HM		1,000/10,000	1,200/12,000	35
Van, Ram 3500 w/Factory 7-Way	01-03										
EAGLE											
Vision	93-97	43	SQ2	1-1/4	36170		JR,TA,HM	36061	300/3,500		40
FIAT											
500 Except Abarth	12-17	28	SQ1	1-1/4	24873	0	GP,JR	3593	200/2,000		30
500X	16-16	26	RT3	2	76019		HM		675/4,500		30
FORD											
Aerostar Extended Body	97-97	50	SQ3	2	37136				500/5,000	600/6,000	40
C-MAX	13-16	29	SQ1	1-1/4	24896		GP,JR,KH	3593	200/2,000		25
Crown Victoria	92-97	36	SQ1	1-1/4	24526		CA,GP	3592	200/2,000		25
		39	SQ2	1-1/4	36116		CA,GP	36063	300/3,500		30
		38	SQ3	2	41116		CA,GP		350/3,500	750/6,000	30
Crown Victoria	98-09	36	SQ1	1-1/4	24526		CA,GP	3592	200/2,000		25
		39	SQ2	1-1/4	36116		CA,GP	36063	300/3,500		30
		38	SQ3	2	41116		CA,GP		350/3,500	750/6,000	30
E-150 Econoline	95-02	19	RT4	2	75703		CS,HM		600/6,000	1,000/10,000	20
		37	SQ5	2	41906		@,HM,HY		1,000/10,000	1,200/12,000	30
E-150 Econoline w/Factory 7-Way	97-02										

- @ Ultra Frame ball mount must be used to achieve maximum weight carrying rating.
- BF Requires standard bumper. Will not fit with step bumper.
- CA Models with dual exhaust require exhaust modification.
- CS Will fit with full-size spare tire stowed under vehicle.
- DH Cannot be installed on 1987-97 vehicles with factory step bumpers unless step bumper and its mounting brackets are permanently removed and standard factory bumper is installed.
- GP Hitch crosstube concealed behind bumper.
- HM Hitch crosstube is visible beneath bumper.
- HY Ultra Frame ball mount DT #4283/HH #80125 cannot be used in rise position on vehicles with step bumpers.
- JR Exhaust must be temporarily lowered for installation.
- KH Minor heat shield modification may be required.
- TA Trunk access required for hitch installation.

RECEIVER HITCH APPLICATION GUIDE

F

FORD

T-ONE						TOW HARNESS						4-FLAT WIRING				REQ. 4 FLAT WIRING		BRAKE CONTROL HARNESS	IN	
PC	T-ONE	FN	IN	AMP	CP	PC	TOW HARN	FN	IN	AMP	CP	TYPE	ELEC	POS	CHOICE 1	CHOICE 2	6-WAY ADAPTER			7-WAY ADAPTER
DODGE (Continued)																				
E1	118328	BN	5	7.5									A	SUV7	119180	20252	20320	20321	20224	
E1	118328	BN	5	7.5									A	SUV7	119180	20252	20320	20321	20224	
E1	118368	BN	5	7.5									A	SUV5	119180	20252	20320	20321	20224	
E3	118381	BN	5	7.5									A	SUV5	119180	20252	20320	20321	20224	
E3	118381	BN	5	7.5									A	SUV5	119180	20252	20320	20321	20224	
						20135		RD	10			Both	A	SUV5	119180	20252	20320	20321	20224	
E1	118368	BN	5	7.5									A	SUV5	119180	20252	20320	20321	20224	
E3	118381	BN	5	7.5									A	SUV5	119180	20252	20320	20321	20224	
E3	118381	BN	5	7.5									A	SUV5	119180	20252	20320	20321	20224	
						20135		RD	10			Both	A	SUV5	119180	20252	20320	20321	20224	
E1	118368	BN	5	7.5									A	SUV5	119180	20252	20320	20321	20224	
E3	118381	BN	5	7.5									A	SUV5	119180	20252	20320	20321	20224	
E3	118381	BN	5	7.5									A	SUV5	119180	20252	20320	20321	20224	
						20135		RD	10			Both	A	SUV5	119180	20252	20320	20321	20224	
EAGLE																				
													B	PC3,4	119130	119178				
FIAT																				
E20	118546	CH	45	4,2,7.5	X								B,E	PC1,2	119148	119180				
E24	118693	CH	45	4,2,7.5	X								BT	SUV1,2	119251	119191				
FORD																				
E5	118344	BN	10	7.5									A	SUV1,2	119180	20252	20320	20321	20224	
													BM	PC1,2	119251	119191				
E9	118326		20	7.5									A,E	PC3,4	119148	119180	20320	20321	20224	
													B,E	PC3,4	119148	119180	20320	20321	20224	
E5	118344	BN	10	7.5									A	SUV1,2	119180	20252	20320	20321	20224	3035-P 5
						20119		RD	10			Both	A	SUV6	119180	20252				
						118015		RD	10			7-Way								

- A** 2 wire system.
- B** 3 wire system. Converter required.
- BM** Multiplexed wiring system. ModuLite® HD Plus or Ultra required.
- BN** Exterior mounted plug on some or all models. May require an aftermarket electrical mounting box or bracket. (Sold separately)

- BT** Shared Brake/Tail multiplexed wiring system. ModuLite® HD Plus or Ultra required.
- CH** T-One is equipped with circuit protected ModuLite® module.
- E** ModuLite® required.
- RD** For vehicles equipped with factory tow package may require additional components or may be used as a replacement harness.

- RT3** Round Tube Class III 2"
- RT4** Round Tube Class IV 2"
- SQ1** Square Tube Class I
- SQ2** Square Tube Class II
- SQ3** Square Tube Class III
- SQ4** Square Tube Class IV
- SQ5** Square Tube Class V

RECEIVER HITCHES

RECEIVER HITCH APPLICATION GUIDE

MODEL / STYLE	YEAR	TRAILER HITCHES									
		PC	REC TYPE	REC SIZE	PART #	NO DRILL	FOOTNOTES	OPTIONAL DRAWBAR	WC (LBS.)	WD (LBS.)	IN
FORD (Continued)											
E-150 Econoline	00-02	35	SQ5	2	41926	0	@,HM		1,000/10,000	1,200/12,000	30
		41	SQ5	2	41945	0	@,HM		1,500/10,000	1,200/12,000	30
E-150 Econoline	03-07	19	RT4	2	75703		CS,HM		600/6,000	1,000/10,000	20
		37	SQ5	2	41906		@,HM,HY		1,000/10,000	1,200/12,000	30
		35	SQ5	2	41926	0	@,HM		1,000/10,000	1,200/12,000	30
		41	SQ5	2	41945	0	@,HM		1,500/10,000	1,200/12,000	30
E-150 Econoline w/Factory 7-Way	04-09										
E-150 Econoline	08-08	19	RT4	2	75703		CS,HM		600/6,000	1,000/10,000	20
		37	SQ5	2	41906		@,HM,HY		1,000/10,000	1,200/12,000	30
		35	SQ5	2	41926	0	@,HM		1,000/10,000	1,200/12,000	30
		41	SQ5	2	41945	0	@,HM		1,500/10,000	1,200/12,000	30
E-150 Econoline	09-14	19	RT4	2	75703	0	CS,HM		600/6,000	1,000/10,000	20
		37	SQ5	2	41906		@,HM,HY		1,000/10,000	1,200/12,000	30
		35	SQ5	2	41926	0	@,HM		1,000/10,000	1,200/12,000	30
		41	SQ5	2	41945	0	@,HM		1,500/10,000	1,200/12,000	30
E-150 Econoline w/Factory 4-Flat (Prepped Class I Towing Package)	09-12										
E-150 Econoline w/Factory 7-Way (Prepped Class II Towing Package)	09-12										
E-250 Econoline	95-02	19	RT4	2	75703		CS,HM		600/6,000	1,000/10,000	20
		37	SQ5	2	41906		@,HM,HY		1,000/10,000	1,200/12,000	30
E-250 Econoline w/Factory 7-Way	97-09										
E-250 Econoline	00-02	35	SQ5	2	41926	0	@,HM		1,000/10,000	1,200/12,000	30
		41	SQ5	2	41945	0	@,HM		1,500/10,000	1,200/12,000	30
E-250 Econoline	03-07	19	RT4	2	75703		CS,HM		600/6,000	1,000/10,000	20
		37	SQ5	2	41906		@,HM,HY		1,000/10,000	1,200/12,000	30
		35	SQ5	2	41926	0	@,HM		1,000/10,000	1,200/12,000	30
		41	SQ5	2	41945	0	@,HM		1,500/10,000	1,200/12,000	30
E-250 Econoline	08-08	19	RT4	2	75703		CS,HM		600/6,000	1,000/10,000	20
		37	SQ5	2	41906		@,HM,HY		1,000/10,000	1,200/12,000	30
		35	SQ5	2	41926	0	@,HM		1,000/10,000	1,200/12,000	30
		41	SQ5	2	41945	0	@,HM		1,500/10,000	1,200/12,000	30
E-250 Econoline	09-14	19	RT4	2	75703		CS,HM		600/6,000	1,000/10,000	20
		37	SQ5	2	41906		@,HM,HY		1,000/10,000	1,200/12,000	30
		35	SQ5	2	41926	0	@,HM		1,000/10,000	1,200/12,000	30
		41	SQ5	2	41945	0	@,HM		1,500/10,000	1,200/12,000	30
E-250 Econoline w/Factory 4-Flat (Prepped Class I Towing Package)	09-12										
E-250 Econoline w/Factory 7-Way (Prepped Class II Towing Package)	09-12										
E-350 Econoline	95-02	19	RT4	2	75703		CS,HM		600/6,000	1,000/10,000	20
		37	SQ5	2	41906		@,HM,HY		1,000/10,000	1,200/12,000	30
E-350 Econoline w/Factory 7-Way	97-02										
E-350 Econoline	00-02	35	SQ5	2	41926	0	@,HM		1,000/10,000	1,200/12,000	30
		41	SQ5	2	41945	0	@,HM		1,500/10,000	1,200/12,000	30
E-350 Econoline Super Duty	03-07	19	RT4	2	75703		CS,HM		600/6,000	1,000/10,000	20
		37	SQ5	2	41906		@,HM,HY		1,000/10,000	1,200/12,000	30
		35	SQ5	2	41926	0	@,HM		1,000/10,000	1,200/12,000	30
		41	SQ5	2	41945	0	@,HM		1,500/10,000	1,200/12,000	30

@ Ultra Frame ball mount must be used to achieve maximum weight carrying rating.
 CS Will fit with full-size spare tire stowed under vehicle.

HM Hitch cross-tube is visible beneath bumper.
 HY Ultra Frame ball mount DT #4283/HH #80125 cannot be used in rise position on vehicles with step bumpers.

RECEIVER HITCH APPLICATION GUIDE

F

FORD

T-ONE						TOW HARNESS						4-FLAT WIRING				REQ. 4 FLAT WIRING		7-WAY HARDWIRE	BRAKE CONTROL HARNESS	IN	
PC	T-ONE	FN	IN	AMP	CP	PC	TOW HARN	FN	IN	AMP	CP	TYPE	ELEC	POS	CHOICE 1	CHOICE 2	6-WAY ADAPTER				7-WAY ADAPTER
FORD (Continued)																					
E5	118344	BN	10	7.5									A	SUV1,2	119180	20252	20320	20321	20224	3035-P	5
													A	SUV1,2	119180	20252	20320	20321	20224	3035-P	5
						118015 20119	RD RD	10 10				7-Way Both	A	SUV6	119180	20252					
E17	118551	CH	45	4.2,7.5	X								A,E	SUV1,2	119148	119180	20320	20321	20224	3035-P	5
E17	118551	CH	45	4.2,7.5	X								A,E	SUV1,2	119148	119180	20320	20321	20224	3034-P	20
						E3	118260	BN	10	7.5		4-Flat	A	SUV6	119180	20252					
						E14	118261	BN	10			7-Way	A	SUV6	119180	20252					
E5	118344	BN	10	7.5									A	SUV1,2	119180	20252	20320	20321	20224	3035-P	5
						20119 118015	RD RD	10 10				Both 7-Way	A	SUV6	119180	20252					
E5	118344	BN	10	7.5									A	SUV1,2	119180	20252	20320	20321	20224	3035-P	5
													A	SUV1,2	119180	20252	20320	20321	20224	3035-P	5
E17	118551	CH	45	4.2,7.5	X								A,E	SUV1,2	119148	119180	20320	20321	20224	3035-P	5
E17	118551	CH	45	4.2,7.5	X								A,E	SUV1,2	119148	119180	20320	20321	20224	3034-P	20
						E3	118260	BN	10	7.5		4-Flat	A	SUV6	119180	20252					
						E14	118261	BN	10			7-Way	A	SUV6	119180	20252					
E5	118344	BN	10	7.5									A	SUV1,2	119180	20252	20320	20321	20224	3035-P	5
						20119 118015	RD RD	10 10				Both 7-Way	A	SUV6	119180	20252					
E5	118344	BN	10	7.5									A	SUV1,2	119180	20252	20320	20321	20224	3035-P	5
													A	SUV1,2	119180	20252	20320	20321	20224	3035-P	5

A 2 wire system.

BN Exterior mounted plug on some or all models. May require an aftermarket electrical mounting box or bracket. (Sold separately)

CH T-One is equipped with circuit protected ModuLite® module.

E ModuLite® required.

RD For vehicles equipped with factory tow package may require additional components or may be used as a replacement harness.

RT4 Round Tube Class IV 2"

SQ5 Square Tube Class V

RECEIVER HITCHES

RECEIVER HITCH APPLICATION GUIDE

MODEL / STYLE	YEAR	TRAILER HITCHES									
		PC	REC TYPE	REC SIZE	PART #	NO DRILL	FOOTNOTES	OPTIONAL DRAWBAR	WC (LBS.)	WD (LBS.)	IN
FORD (Continued)											
E-350 Econoline Super Duty w/Factory 7-Way	03-09										
E-350 Econoline Super Duty	08-08	19	RT4	2	75703		CS, HM		600/6,000	1,000/10,000	20
		37	SQ5	2	41906		@, HM, HY		1,000/10,000	1,200/12,000	30
		35	SQ5	2	41926	0	@, HM		1,000/10,000	1,200/12,000	30
E-350 Econoline Super Duty	09-14	41	SQ5	2	41945	0	@, HM		1,500/10,000	1,200/12,000	30
		19	RT4	2	75703		CS, HM		600/6,000	1,000/10,000	20
		37	SQ5	2	41906		@, HM, HY		1,000/10,000	1,200/12,000	30
E-350 Econoline Super Duty	09-14	35	SQ5	2	41926	0	@, HM		1,000/10,000	1,200/12,000	30
		41	SQ5	2	41945	0	@, HM		1,500/10,000	1,200/12,000	30
E-350 Econoline Super Duty w/Factory 7-Way (Prepped Class II Towing Package)	09-12										
Edge Except Sport	07-10	33	SQ2	1-1/4	36447	0	GP, JR, KH	36051	300/3,500		45
		20	SQ3	2	75992		GP, KH, JR		400/4,000	400/4,000	55
Edge Sport	09-10	37	SQ3	2	75686	0	GP, JR, KH		350/3,500		45
Edge Except Sport	11-14	20	SQ3	2	75992		GP, KH, JR		400/4,000	400/4,000	55
Edge Sport	11-14	38	SQ3	2	75728	0	GP, JR, KH		525/3,500	525/4,000	45
Edge Except Sport & Titanium Models	15-16	28	RT3	2	75214	0	JR, HM, SV, TW		600/4,000	600/4,000	30
		35	SQ3	2	75234	0	GP, TA, SV, JR		675/4,500	675/4,500	45
Edge Titanium and Sport Models Only	15-16	35	SQ3	2	75234	0	GP, TA, SV, JR		675/4,500	675/4,500	45
Edge Titanium Model Only	15-15	28	RT3	2	75214	0	JR, HM, SV, TW		600/4,000	600/4,000	30
Escape	01-03	38	RT3	2	75118	0	HM, KH		350/3,500	500/5,000	35
		50	SQ3	2	37136		KH		500/5,000	600/6,000	60
Escape	04-04	38	RT3	2	75118	0	HM		350/3,500	500/5,000	35
		50	SQ3	2	37136				500/5,000	600/6,000	60
Escape	05-07	22	SQ2	1-1/4	36501		HM	36051	300/3,500		20
		34	RT3	2	75751	0	HM		675/4,500	675/5,250	25
Escape	08-12	22	SQ2	1-1/4	36501		HM	36051	300/3,500		20
		34	RT3	2	75751	0	HM		675/4,500	675/5,250	25
Escape	13-16	38	SQ2	1-1/4	36524	0	HM	36071	300/3,500		15
		38	SQ2	1-1/4	36529	0	GP, JR, KH	36071	300/3,500		20
		43	SQ3	2	75782	0	GP, JR, KH		525/3,500	525/5,000	20
		40	RT3	2	75758	0	HM		675/4,500	675/5,000	15
Escape	17-17	38	SQ2	1-1/4	36524	0	HM	36071	300/3,500		15
		38	SQ2	1-1/4	36529	0	GP, JR, KH	36071	300/3,500		20
		43	SQ3	2	75782	0	GP, JR, KH		525/3,500	525/5,000	20
		40	RT3	2	75758	0	HM		675/4,500	675/5,000	15
Excursion	00-03										
Excursion w/Factory 7-Way	00-05										
Expedition	97-02	42	SQ3	2	75071	0	GP		500/5,000	800/8,000	15
		41	SQ4	2	41527	0	GP		600/6,000	1,000/10,000	15
Expedition w/Factory 7-Way	97-11										
Expedition	03-03										
Expedition	13-13										
Explorer	95-00	32	SQ2	1-1/4	36246	0	HM	36051	300/3,500		15
		34	RT3	2	75083	0	JF, HM		500/5,000	600/6,000	15
		31	SQ3	2	75096	0	HM		500/5,000	750/7,500	15
Explorer w/Factory 7-Way	00-05										

@ Ultra Frame ball mount must be used to achieve maximum weight carrying rating.
 CS Will fit with full-size spare tire stowed under vehicle.
 GP Hitch cross-tube concealed behind bumper.
 HM Hitch cross-tube is visible beneath bumper.
 HY Ultra Frame ball mount DT #4283/HH #80125 cannot be used in rise position on vehicles with step bumpers.
 JF Will not fit with 16" spare tire.

JR Exhaust must be temporarily lowered for installation.
 KH Minor heat shield modification may be required.
 SV Trimming or removal of under body appearance panel may be required.
 TA Trunk access required for hitch installation.
 TW Receiver hitch may limit hands-free liftgate sensor range

RECEIVER HITCH APPLICATION GUIDE

T-ONE						TOW HARNESS						4-FLAT WIRING				REQ. 4 FLAT WIRING		7-WAY HARDWIRE	BRAKE CONTROL HARNESS	IN	
PC	T-ONE	FN	IN	AMP	CP	PC	TOW HARN	FN	IN	AMP	CP	TYPE	ELEC	POS	CHOICE 1	CHOICE 2	6-WAY ADAPTER				7-WAY ADAPTER
FORD (Continued)																					
							20119 118015	RD RD	10 10			Both 7-Way	A	SUV6	119180	20252					
E17	118551	CH	45	4.2,7.5	X								A,E	SUV1,2	119148	119180	20320	20321	20224	3035-P	5
E17	118551	CH	45	4.2,7.5	X								A,E	SUV1,2	119148	119180	20320	20321	20224	3034-P	20
						E3 E14	118260 118261	BN BN	10 10	7.5		4-Flat 7-Way	A	SUV6	119180	20252					
E17	118551	CH	45	4.2,7.5	X								N	SUV1,2		119251	20320	20321			
E17	118551	CH	45	4.2,7.5	X								N	SUV1,2		119251	20320	20321			
E21	118515	CH	45	4.2,7.5	X								N	SUV1,2		119251	20320	20321			
E21	118515	CH	45	4.2,7.5	X								N	SUV1,2		119251	20320	20321			
E16	118669	CH,BN	45	4.2,7.5	X								A,E	PC1,2	119180	119148					
E13	118677	CH,BN	45	4.2,7.5	X								B,E	SUV1,2	119180	119148					
E13	118677	CH,BN	45	4.2,7.5	X								B,E	SUV1,2	119180	119180					
E9	118343	HG,RW	10	2.1,5									B	SUV1,2	119130	119178	20320	20321	20224		
													B,E	SUV1,2	119148	119180	20320	20321	20224		
E17	118426	BN,CH	45	2.1,4.2	X								B,E	SUV1,2	119148	119180	20320	20321	20224		
E17	118551	CH	45	4.2,7.5	X	E1	118251	BN,QP,RD	5	7.5		4-Flat	A	SUV1,2	119180	20252	20320	20321	20224		
E18	118566	BN,CH	45	4.2,7.5	X								B,E	SUV1,2	119148	119180	20320	20321	20224		
E17	118715	CH	45	4.2,7.5	X								B,E	SUV1,2	119148	119180					
E5	118344	BN	10	7.5									A	SUV1,2	119180	20252					
							118015 20119	RD RD	10 10			7-Way Both	A	SUV6	119180	20252				3035-P	5
E5	118344	BN	10	7.5									A	SUV1,2	119180	20252	20320	20321	20224	3035-P	5
							20119 118015	RD RD	10 10			Both 7-Way	A	SUV6	119180	20252					
						E5	118344	BN	10	7.5		4-Flat	A	SUV1,2	119180	20252					
													A	PU5					20224	3034-P	20
E16	118345	BN,CH	45	2.1,4.2		E2	118241	BN,RD	5	7.5		4-Flat	B,E	SUV1,2	119148	119180	20320	20321	20224		
							20119 118015	RD RD	10 10			Both 7-Way	A	SUV6	119180	20252					

- A** 2 wire system.
- B** 3 wire system. Converter required.
- BN** Exterior mounted plug on some or all models. May require an aftermarket electrical mounting box or bracket. (Sold separately)
- CH** T-One is equipped with circuit protected ModuLite® module.
- E** ModuLite® required.
- HG** T-One incorporates taillight converter.
- N** DO NOT cut or splice vehicle wiring. Only use approved T-One or see auto dealer for trailer tow wiring kit.
- QP** Will not fit vehicles with backup sensors built into rear bumper.
- RD** For vehicles equipped with factory tow package may require additional components or may be used as a replacement harness.
- RW** On some models it may require an upgraded flasher or ModuLite®.

- RT3** Round Tube Class II 2"
- RT4** Round Tube Class IV 2"
- SQ2** Square Tube Class II
- SQ3** Square Tube Class III
- SQ4** Square Tube Class IV
- SQ5** Square Tube Class V

RECEIVER HITCH APPLICATION GUIDE

MODEL / STYLE	YEAR	TRAILER HITCHES									
		PC	REC TYPE	REC SIZE	PART #	NO DRILL	FOOTNOTES	OPTIONAL DRAWBAR	WC (LBS.)	WD (LBS.)	IN
FORD (Continued)											
Explorer 2 Dr. Sport	01-02	32	SQ2	1-1/4	36246	0	HM	36051	300/3,500		15
		34	RT3	2	75083	0	JF, HM		500/5,000	600/6,000	15
		31	SQ3	2	75096	0	HM		500/5,000	750/7,500	15
Explorer 4 Dr.	01-01	32	SQ2	1-1/4	36246	0	HM	36051	300/3,500		15
		34	RT3	2	75083	0	JF, HM		500/5,000	600/6,000	15
		31	SQ3	2	75096	0	HM		500/5,000	750/7,500	15
Explorer 4 Dr.	02-03	51	RT3	2	75132	0	HM, KL		500/5,000	800/8,000	20
Explorer 4 Dr.	04-05	51	RT3	2	75132	0	HM, KL		500/5,000	800/8,000	20
Explorer w/1-1/4" Receivers	06-10	39	RT3	2	75437	0	HM, KL		500/5,000	800/8,000	25
Explorer w/Factory 7-Way	06-14										
Explorer	11-17	20	RT3	2	757101	0	HM, JR, L		400/4,000	500/5,000	45
		20	SQ3	2	76034	0	HM, JR, L		675/4,500	500/5,000	45
Explorer Sport Trac	01-01	32	RT3	2	75112	0	CS		500/5,000	600/6,000	15
Explorer Sport Trac	02-03	32	RT3	2	75112	0	CS		500/5,000	600/6,000	15
Explorer Sport Trac	04-05	32	RT3	2	75112	0	CS		500/5,000	600/6,000	15
Explorer Sport Trac w/Factory 7-Way	07-10										
F Super Duty Cab & Chassis, w/34" Wide Frames & 161" Wheelbase	89-97	30	SQ4	2	40050				600/6,000	1,000/10,000	40
F Super Duty Cab & Chassis, w/34" Wide Frames & 161" Wheelbase & w/Deep Drop Bumper	89-97	29	SQ3	2	41504		FP, K, M		500/5,000	1,000/10,000	40
F-150 Flareside	97-03	49	RT3	2	37133	0			500/5,000	750/7,500	25
		28	SQ3	2	75065	0	GP		500/5,000	800/8,000	30
		54	RT4	2	37130	0			700/7,000	1,200/12,000	25
		27	RT4	2	75740	0	FP, HM		900/6,000	1,000/10,000	20
		48	SQ5	2	41920	0	@, GP, SU		1,000/10,000	1,300/13,000	30
F-150 Styleside	97-03	49	RT3	2	37133	0			500/5,000	750/7,500	25
		28	SQ3	2	75065	0	GP		500/5,000	800/8,000	30
		54	RT4	2	37130	0			700/7,000	1,200/12,000	25
		27	RT4	2	75740	0	FP, HM		900/6,000	1,000/10,000	20
		48	SQ5	2	41920	0	@, GP, SU		1,000/10,000	1,300/13,000	30
F-150 w/Factory 7-Way	97-17										
F-150 SuperCrew	00-03	49	RT3	2	37133	0			500/5,000	750/7,500	25
		28	SQ3	2	75065	0	GP		500/5,000	800/8,000	30
		54	RT4	2	37130	0			700/7,000	1,200/12,000	25
		27	RT4	2	75740	0	FP, HM		900/6,000	1,000/10,000	20
		48	SQ5	2	41920	0	@, GP, SU		1,000/10,000	1,300/13,000	30
F-150 SuperCrew, w/Factory 7-Way	00-03										
F-150	04-04	49	RT3	2	37133		VB		500/5,000	750/7,500	45
		56	RT4	2	41549	0	HM, VB, KM		600/6,000	1,000/10,000	30
		50	RT4	2	75156	0	HM, VB, KM		600/6,000	800/8,000	30
F-150 SuperCrew, 5.5 ft. Bed, w/Factory 7-Way	04-05										
F-150	05-05	49	RT3	2	37133		VB		500/5,000	750/7,500	45
		56	RT4	2	41549	0	HM, VB, KM		600/6,000	1,000/10,000	30
		50	RT4	2	75156	0	HM, VB, KM		600/6,000	800/8,000	30
F-150	06-08	25	SQ4	2	75506	0	CP, HM		600/6,000	1,000/10,000	20
		37	SQ5	2	41933	0	@, CP, HM		1,000/10,000	1,200/12,000	20
F-150 SuperCrew, 5.5 & 6.5 ft. Beds, w/Factory 7-Way	06-17										

- @ Ultra Frame ball mount must be used to achieve maximum weight carrying rating.
- CP Fits all models without factory installed receiver.
- CS Will fit with full-size spare tire stowed under vehicle.
- FP Spare tire repositioning and/or modification of spare tire carrier may be required.
- GP Hitch crosstube concealed behind bumper.
- HM Hitch crosstube is visible beneath bumper.
- JF Will not fit with 16" spare tire.
- JR Exhaust must be temporarily lowered for installation.

- K Adapter kit (#1685) required with DT #41504/HH #87480/RS #37081 & RS #44143 for 1980 and later F-Series pickups.
- KL Hitch is designed to attach beneath the OEM hitch.
- KM Does not work with models originally equipped with OEM hitch.
- L Exhaust repositioning required.
- M Will fit with heavy-duty suspension.
- SU Hitches produced before 03/11/08 are rated at 1000/10000 WC & 1200/12000 WD.
- VB Will not fit vehicles with vibration damper installed at rear of frame on drivers side.

RECEIVER HITCH APPLICATION GUIDE

T-ONE						TOW HARNESS						4-FLAT WIRING				REQ. 4 FLAT WIRING		BRAKE CONTROL HARNESS	IN	
PC	T-ONE	FN	IN	AMP	CP	PC	TOW HARN	FN	IN	AMP	CP	TYPE	ELEC	POS	CHOICE 1	CHOICE 2	6-WAY ADAPTER			7-WAY ADAPTER
FORD (Continued)																				
E5	118344	BN	10	7.5									A	SUV1,2	119180	20252	20320	20321	20224	
E16	118345	BN,CH	45	2.1,4.2		E2	118241	BN,RD	5	7.5		4-Flat	B,E	SUV1,2	119148	119180	20320	20321	20224	
E5	118344	BN	10	7.5									A	SUV1,2	119180	20252	20320	20321	20224	3035-P
													A	SUV1,2	119180	20252	20320	20321	20224	3035-P
													B	SUV1,2	119130	119178	20320	20321	20224	3035-P
							20119 118015	RD RD	10 10			Both 7-Way	A	SUV6	119180	20252				
E11	118540	BN	5	7.5		E15	118272		20			7-Way	B,E	SUV3,4	119148	119180	20320	20321	20224	3035-P
													A	SUV1,2	119180	20252	20320	20321	20224	
E5	118344	BN	10	7.5									A	SUV1,2	119180	20252	20320	20321	20224	
							20119 118015	RD RD	10 10			Both 7-Way	A	SUV6	119180	20252				3035-P
													A	PU1,2	119180	20252	20320	20321	20224	
													A	PU1,2	119180	20252	20320	20321	20224	
E5	118344	BN	10	7.5		E19	118242	BN,RD	5			7-Way	A	PU1,2	119180	20252	20320	20321	20224	3035-P
						E19	118242	BN,RD	5			7-Way	A	PU1,2	119180	20252	20320	20321	20224	3035-P
							20119 118015	RD RD	10 10			Both 7-Way	A	PU3	119180	20252				
E5	118344	BN	10	7.5		E19	118242	BN,RD	5			7-Way	A	PU1,2	119180	20252	20320	20321	20224	3035-P
							20119 118015	RD RD	10 10			Both 7-Way	A	PU3	119180	20252				
						E19	118247	BN,RD	5			7-Way	A	PU3	119180	20252	20320	20321	20224	3035-P
							20119 118015	RD RD	10 10			Both 7-Way	A	PU3	119180	20252				
													A	PU3	119180	20252	20320	20321	20224	3035-P
													A	PU3	119180	20252	20320	20321	20224	3035-P
							118015 20119	RD RD	10 10			7-Way Both	A	PU3	119180	20252				

A 2 wire system.
B 3 wire system. Converter required.
BN Exterior mounted plug on some or all models. May require an aftermarket electrical mounting box or bracket. (Sold separately)

CH T-One is equipped with circuit protected Modulite® module.
E Modulite® required.
RD For vehicles equipped with factory tow package may require additional components or may be used as a replacement harness.

RT3 Round Tube Class III 2"
RT4 Round Tube Class IV 2"
SQ2 Square Tube Class II
SQ3 Square Tube Class III
SQ4 Square Tube Class IV
SQ5 Square Tube Class V

RECEIVER HITCH APPLICATION GUIDE

MODEL / STYLE	YEAR	TRAILER HITCHES									
		PC	REC TYPE	REC SIZE	PART #	NO DRILL	FOOTNOTES	OPTIONAL DRAWBAR	WC (LBS.)	WD (LBS.)	IN
FORD (Continued)											
F-150	09-14	20	SQ4	2	75691	0	CP,GP		600/6,000	1,200/12,000	20
F-150	15-17	45	RT4	2	75216	0	HM,JL		900/6,000	1,200/12,000	30
		51	RT4	2	75910	0	HM,JL		900/6,000	1,200/12,000	30
		27	RT4	2	75938	0	HM,JL		900/6,000	800/8,000	30
F-150 Heritage Flareside	04-04	49	RT3	2	37133	0			500/5,000	750/7,500	25
		28	SQ3	2	75065	0	GP		500/5,000	800/8,000	30
		54	RT4	2	37130	0			700/7,000	1,200/12,000	25
		27	RT4	2	75740	0	FP,HM		900/6,000	1,000/10,000	20
		48	SQ5	2	41920	0	@,GP,SU		1,000/10,000	1,300/13,000	30
F-150 Heritage Styleside	04-04	49	RT3	2	37133	0			500/5,000	750/7,500	25
		28	SQ3	2	75065	0	GP		500/5,000	800/8,000	30
		54	RT4	2	37130	0			700/7,000	1,200/12,000	25
		27	RT4	2	75740	0	FP,HM		900/6,000	1,000/10,000	20
		48	SQ5	2	41920	0	@,GP,SU		1,000/10,000	1,300/13,000	30
F-150 Heritage w/Factory 7-Way	04-04										
F-250 Heavy Duty	97-97	49	RT3	2	37133		GU		500/5,000	750/7,500	35
		34	SQ3	2	75038				500/5,000	800/8,000	30
		30	SQ4	2	40050				600/6,000	1,000/10,000	40
		25	SQ4	2	41004		GP		600/6,000	1,000/10,000	30
		54	RT4	2	37130		GU		700/7,000	1,200/12,000	35
		45	SQ5	2	41904		@,GP,HD		1,000/10,000	1,200/12,000	30
		54	SQ5	2-1/2	45502		#,GU		1,200/12,000	1,700/14,000	45
F-250 Heavy Duty, w/Deep Drop Bumper	97-97	29	SQ3	2	41504		FP,K,M		500/5,000	1,000/10,000	40
F-250 Styleside	97-99	49	RT3	2	37133	0			500/5,000	750/7,500	25
		28	SQ3	2	75065	0	GP		500/5,000	800/8,000	30
		54	RT4	2	37130	0			700/7,000	1,200/12,000	25
		27	RT4	2	75740	0	FP,HM		900/6,000	1,000/10,000	20
		48	SQ5	2	41920	0	@,GP,SU		1,000/10,000	1,300/13,000	30
F-250 Styleside, w/Factory 7-Way	97-99										
F-250 Super Duty Except Cab & Chassis	99-01	49	RT3	2	37133				500/5,000	750/7,500	30
		54	RT4	2	37130				700/7,000	1,200/12,000	30
		27	RT4	2	75740	0	FP,HM		900/6,000	1,000/10,000	20
		51	SQ5	2	41922	0	@,GP		1,000/10,000	1,200/12,000	15
		55	SQ5	2	41931	0	@,HM,SH		1,200/12,000	1,500/15,000	30
		60	SQ5	2-1/2	45508	0	#,CS,EF,HM,LT,M		2,000/18,000	2,500/18,000	50
F-250 Super Duty Except Cab & Chassis, w/Factory 7-Way	99-14										
F-250 Super Duty w/Deep Drop Bumper	99-01	72	SQ5	2-1/2	45514	0	#		1,200/12,000	1,700/14,000	20
F-250 Super Duty w/Deep Drop Bumper, w/Factory 7-Way	99-04										
F-250 Super Duty Except Cab & Chassis	02-04	49	RT3	2	37133				500/5,000	750/7,500	30
		54	RT4	2	37130				700/7,000	1,200/12,000	30
		27	RT4	2	75740	0	FP,HM		900/6,000	1,000/10,000	20
		51	SQ5	2	41922	0	@,GP		1,000/10,000	1,200/12,000	15
		55	SQ5	2	41931	0	@,HM,SH		1,200/12,000	1,500/15,000	30
		60	SQ5	2-1/2	45508	0	#,CS,EF,HM,LT,M		2,000/18,000	2,500/18,000	50
F-250 Super Duty w/Deep Drop Bumper	02-04	72	SQ5	2-1/2	45514	0	#		1,200/12,000	1,700/14,000	20
F-250 Super Duty Except Cab & Chassis	05-07	27	RT4	2	75740	0	FP,HM		900/6,000	1,000/10,000	20
		55	SQ5	2	41931	0	@,EB,HM,SH		1,200/12,000	1,500/15,000	30
		60	SQ5	2-1/2	45508	0	#,CS,EF,HM,LT,M		2,000/18,000	2,500/18,000	50

- # Titan hitches require use of a 2-1/2" shank Titan ball mount.
- @ Ultra Frame ball mount must be used to achieve maximum weight carrying rating.
- CP Fits all models without factory installed receiver.
- CS Will fit with full-size spare tire stowed under vehicle.
- EB Factory electrical bracket will NOT fit with this hitch. Must use aftermarket electrical box or bracket.
- EF Fits all models with standard bumpers.
- FP Spare tire repositioning and/or modification of spare tire carrier may be required.
- GP Hitch cross-tube concealed behind bumper.
- GU Will not fit vehicles with factory or aftermarket lower Fascia/Rollpan or Tube Bumper.
- HD Will not fit 6 ft. bed pickups except 6 ft. Super Cab.
- HM Hitch cross-tube is visible beneath bumper.
- JL Installation requires OEM bumper and brackets.
- K Adapter kit (#1685) required with DT #41504/HH #87480/RS #37081 & RS #44143 for 1980 and later F-Series pickups.
- LT Requires removal of factory hitch if equipped.
- M Will fit with heavy-duty suspension.
- SH Hitches produced before 09/27/07 are rated at 1200/12000 WC & 1400/14000 WD.
- SU Hitches produced before 03/11/08 are rated at 1000/10000 WC & 1200/12000 WD.

RECEIVER HITCH APPLICATION GUIDE

T-ONE						TOW HARNESS						4-FLAT WIRING				REQ. 4 FLAT WIRING			BRAKE CONTROL HARNESS		
PC	T-ONE	FN	IN	AMP	CP	PC	TOW HARN	FN	IN	AMP	CP	TYPE	ELEC	POS	CHOICE 1	CHOICE 2	6-WAY ADAPTER	7-WAY ADAPTER	7-WAY HARDWIRE	BRAKE CONTROL HARNESS	IN
FORD (Continued)																					
													A	PU3	119180	20252	20320	20321	20224	3036-P	20
													A	PU3	119180	20252	20320	20321	20224		
E5	118344	BN	10	7.5		E19	118242	BN,RD	5			7-Way	A	PU1,2	119180	20252	20320	20321	20224	3035-P	5
						E19	118242	BN,RD	5			7-Way	A	PU1,2	119180	20252	20320	20321	20224	3035-P	5
							20119 118015	RD RD	10 10			Both 7-Way	A	PU3	119180	20252					
E4	118316	BN	5	7.5									A	PU3	119180	20252	20320	20321	20224	3035-P	5
E4	118316	BN	5	7.5									A	PU3	119180	20252	20320	20321	20224	3035-P	5
						E19	118242	BN,RD	5			7-Way	A	PU1,2	119180	20252	20320	20321	20224	3035-P	5
							20119 118015	RD RD	10 10			Both 7-Way	A	PU3	119180	20252					
						E15	118243	BN,RD	5			7-Way	A	PU1,2	119180	20252	20320	20321	20224	3035-P	5
							20119 118015	RD RD	10 10			Both 7-Way	A	PU3	119180	20252					
						E15	118243	BN,RD	5			7-Way	A	PU1,2	119180	20252	20320	20321	20224	3035-P	5
							20119 118015	RD RD	10 10			Both 7-Way	A	PU3	119180	20252					
													A	PU1,2	119180	20252	20320	20321	20224	3035-P	5
													A	PU1,2	119180	20252	20320	20321	20224	3065-P	5

A 2 wire system.

BN Exterior mounted plug on some or all models. May require an aftermarket electrical mounting box or bracket. (Sold separately)

RD For vehicles equipped with factory tow package may require additional components or may be used as a replacement harness.

RT3 Round Tube Class II 2"

RT4 Round Tube Class IV 2"

SQ3 Square Tube Class III

SQ4 Square Tube Class IV

SQ5 Square Tube Class V

RECEIVER HITCH APPLICATION GUIDE

MODEL / STYLE	YEAR	TRAILER HITCHES									
		PC	REC TYPE	REC SIZE	PART #	NO DRILL	FOOTNOTES	OPTIONAL DRAWBAR	WC (LBS.)	WD (LBS.)	IN
FORD (Continued)											
F-250 Super Duty Except Cab & Chassis	08-16	55	SQ5	2	41931	0	@,EB,HM,SH		1,200/12,000	1,500/15,000	30
		60	SQ5	2-1/2	45508	0	#,CS,EF,HM,LT,M		2,000/18,000	2,500/18,000	50
F-350 Heavy Duty	97-97	49	RT3	2	37133		GU		500/5,000	750/7,500	35
		34	SQ3	2	75038				500/5,000	800/8,000	30
		30	SQ4	2	40050				600/6,000	1,000/10,000	40
		25	SQ4	2	41004		GP		600/6,000	1,000/10,000	30
		54	RT4	2	37130		GU		700/7,000	1,200/12,000	35
		45	SQ5	2	41904		@,GP,HD		1,000/10,000	1,200/12,000	30
54	SQ5	2-1/2	45502		#,GU		1,200/12,000	1,700/14,000	45		
F-350 Heavy Duty, w/Deep Drop Bumper	97-97	29	SQ3	2	41504		FP,K,M		500/5,000	1,000/10,000	40
F-350 Super Duty Cab & Chassis, w/34" Wide Frames	99-00	30	SQ4	2	40050				600/6,000	1,000/10,000	40
		34	SQ4	2	41001		FP		600/6,000	1,000/10,000	40
		30	SQ4	2	41547				750/7,500	1,200/12,000	60
		50	SQ5	2	41938		@,CC		1,200/12,000	1,500/15,000	40
		50	SQ5	2	41947		@		1,600/15,000	1,600/16,000	35
		70	SQ5	2	41943		@		2,400/16,000	1,600/16,000	40
65	SQ5	2-1/2	45516		#		1,200/12,000	1,700/14,000	60		
F-350 Super Duty Cab & Chassis, w/34" Wide Frames & w/Deep Drop Bumper	99-00	29	SQ3	2	41504		FP,M		500/5,000	1,000/10,000	40
F-350 Super Duty Except Cab & Chassis	99-01	49	RT3	2	37133				500/5,000	750/7,500	30
		54	RT4	2	37130				700/7,000	1,200/12,000	30
		27	RT4	2	75740	0	FP,HM		900/6,000	1,000/10,000	20
		51	SQ5	2	41922	0	@,GP		1,000/10,000	1,200/12,000	15
		55	SQ5	2	41931	0	@,HM,SH		1,200/12,000	1,500/15,000	30
		60	SQ5	2-1/2	45508	0	#,CS,EF,HM,LT,M		2,000/18,000	2,500/18,000	50
F-350 Super Duty Except Cab & Chassis, w/Factory 7-Way	99-14										
F-350 Super Duty w/Deep Drop Bumper	99-01	72	SQ5	2-1/2	45514	0	#		1,200/12,000	1,700/14,000	20
F-350 Super Duty w/Deep Drop Bumper, w/Factory 7-Way	99-04										
F-350 Super Duty Cab & Chassis, w/34" Wide Frames	01-04	50	SQ5	2	41947		@		1,600/15,000	1,600/16,000	35
		70	SQ5	2	41943		@		2,400/16,000	1,600/16,000	40
F-350 Super Duty Except Cab & Chassis	02-04	49	RT3	2	37133				500/5,000	750/7,500	30
		54	RT4	2	37130				700/7,000	1,200/12,000	30
		27	RT4	2	75740	0	FP,HM		900/6,000	1,000/10,000	20
		51	SQ5	2	41922	0	@,GP		1,000/10,000	1,200/12,000	15
		55	SQ5	2	41931	0	@,HM,SH		1,200/12,000	1,500/15,000	30
		60	SQ5	2-1/2	45508	0	#,CS,EF,HM,LT,M		2,000/18,000	2,500/18,000	50
F-350 Super Duty w/Deep Drop Bumper	02-04	72	SQ5	2-1/2	45514	0	#		1,200/12,000	1,700/14,000	20
F-350 Super Duty Cab & Chassis, w/34" Wide Frames	05-07	50	SQ5	2	41947		@		1,600/15,000	1,600/16,000	35
		70	SQ5	2	41943		@		2,400/16,000	1,600/16,000	40
F-350 Super Duty Except Cab & Chassis	05-07	27	RT4	2	75740	0	FP,HM		900/6,000	1,000/10,000	20
		55	SQ5	2	41931	0	@,EB,HM,SH		1,200/12,000	1,500/15,000	30
		60	SQ5	2-1/2	45508	0	#,CS,EF,HM,LT,M		2,000/18,000	2,500/18,000	50
F-350 Super Duty Cab & Chassis, w/34" Wide Frames	08-16	50	SQ5	2	41947		@		1,600/15,000	1,600/16,000	35
		70	SQ5	2	41943		@		2,400/16,000	1,600/16,000	40
F-350 Super Duty Except Cab & Chassis	08-16	55	SQ5	2	41931	0	@,EB,HM,SH		1,200/12,000	1,500/15,000	30
		60	SQ5	2-1/2	45508	0	#,CS,EF,HM,LT,M		2,000/18,000	2,500/18,000	50
F-450 Super Duty Cab & Chassis, w/34" Wide Frames	99-04	30	SQ4	2	41547		@		750/7,500	1,200/12,000	60
		50	SQ5	2	41947		@		1,600/15,000	1,600/16,000	35
		70	SQ5	2	41943		@		2,400/16,000	1,600/16,000	40
		65	SQ5	2-1/2	45516		#		1,200/12,000	1,700/14,000	60

- # Titan hitches require use of a 2-1/2" shank Titan ball mount.
- @ Ultra Frame ball mount must be used to achieve maximum weight carrying rating.
- CC Requires minimum of 19" from end of frame rail to spring shackle bracket.
- CS Will fit with full-size spare tire stowed under vehicle.
- EB Factory electrical bracket will NOT fit with this hitch. Must use aftermarket electrical box or bracket.
- EF Fits all models with standard bumpers.
- FP Spare tire repositioning and/or modification of spare tire carrier may be required.
- GP Hitch cross-tube concealed behind bumper.
- GU Will not fit vehicles with factory or aftermarket lower Fascia/Rollpan or Tube Bumper.
- HD Will not fit 6 ft. bed pickups except 6 ft. Super Cab.
- HM Hitch cross-tube is visible beneath bumper.
- K Adapter kit (#1685) required with DT #41504/HH #87480/RS #37081 & RS #44143 for 1980 and later F-Series pickups.
- LT Requires removal of factory hitch if equipped.
- M Will fit with heavy-duty suspension.
- SH Hitches produced before 09/27/07 are rated at 1200/12000 WC & 1400/14000 WD.

RECEIVER HITCH APPLICATION GUIDE

FORD

T-ONE						TOW HARNESS						4-FLAT WIRING				REQ. 4 FLAT WIRING		BRAKE CONTROL HARNESS	IN		
PC	T-ONE	FN	IN	AMP	CP	PC	TOW HARN	FN	IN	AMP	CP	TYPE	ELEC	POS	CHOICE 1	CHOICE 2	6-WAY ADAPTER			7-WAY ADAPTER	7-WAY HARDWIRE
FORD (Continued)																					
													A	PU1,2	119180	20252	20320	20321	20224	3034-P	20
E4	118316	BN	5	7.5									A	PU3	119180	20252	20320	20321	20224	3035-P	5
E4	118316	BN	5	7.5									A	PU3	119180	20252	20320	20321	20224	3035-P	5
													A	PU1,2	119180	20252	20320	20321	20224	3035-P	5
													A	PU1,2	119180	20252	20320	20321	20224	3035-P	5
						E15	118243	BN,RD	5			7-Way	A	PU1,2	119180	20252	20320	20321	20224	3035-P	5
							20119 118015	RD RD	10 10			Both 7-Way	A	PU3	119180	20252					
						E15	118243	BN,RD	5			7-Way	A	PU1,2	119180	20252	20320	20321	20224	3035-P	5
							20119 118015	RD RD	10 10			Both 7-Way	A	PU3	119180	20252					
													A	PU1,2	119180	20252	20320	20321	20224	3035-P	5
													A	PU1,2	119180	20252	20320	20321	20224	3035-P	5
													A	PU1,2	119180	20252	20320	20321	20224	3035-P	5
													A	PU1,2	119180	20252	20320	20321	20224	3035-P	5
													A	PU1,2	119180	20252	20320	20321	20224	3065-P	5
													A	PU1,2	119180	20252	20320	20321	20224	3065-P	5
													A	PU1,2	119180	20252	20320	20321	20224	3034-P	20
													A	PU1,2	119180	20252	20320	20321	20224	3034-P	20
													A	PU1,2	119180	20252	20320	20321	20224	3035-P	5

A 2 wire system.
BN Exterior mounted plug on some or all models. May require an aftermarket electrical mounting box or bracket. (Sold separately)
RD For vehicles equipped with factory tow package may require additional components or may be used as a replacement harness.

RT3 Round Tube Class II 2"
RT4 Round Tube Class IV 2"
SQ3 Square Tube Class III
SQ4 Square Tube Class IV
SQ5 Square Tube Class V

RECEIVER HITCHES

RECEIVER HITCH APPLICATION GUIDE

MODEL / STYLE	YEAR	TRAILER HITCHES									
		PC	REC TYPE	REC SIZE	PART #	NO DRILL	FOOTNOTES	OPTIONAL DRAWBAR	WC (LBS.)	WD (LBS.)	IN
FORD (Continued)											
F-450 Super Duty Cab & Chassis, w/34" Wide Frames	05-07	30	SQ4	2	41547				750/7,500	1,200/12,000	60
		50	SQ5	2	41947		@		1,600/15,000	1,600/16,000	35
		70	SQ5	2	41943		@		2,400/16,000	1,600/16,000	40
		65	SQ5	2-1/2	45516		#		1,200/12,000	1,700/14,000	60
F-450 Super Duty Cab & Chassis, w/34" Wide Frames	08-16	30	SQ4	2	41547		@		750/7,500	1,200/12,000	60
		50	SQ5	2	41947		@		1,600/15,000	1,600/16,000	35
		70	SQ5	2	41943		@		2,400/16,000	1,600/16,000	40
		65	SQ5	2-1/2	45516		#		1,200/12,000	1,700/14,000	60
F-450 Super Duty Except Cab & Chassis	08-10	60	SQ5	2-1/2	45508	0	#,CS,EF,HM,LT,M		2,000/18,000	2,500/18,000	50
F-450 Super Duty Except Cab & Chassis, w/Factory 7-Way	08-15										
F-450 Super Duty Except Cab & Chassis	11-15	60	SQ5	2-1/2	45508	0	#,CS,EF,HM,LT,M		2,000/18,000	2,500/18,000	50
F-550 Super Duty Cab & Chassis, w/34" Wide Frames	99-04	30	SQ4	2	41547		@		750/7,500	1,200/12,000	60
		50	SQ5	2	41947		@		1,600/15,000	1,600/16,000	35
		70	SQ5	2	41943		@		2,400/16,000	1,600/16,000	40
		65	SQ5	2-1/2	45516		#		1,200/12,000	1,700/14,000	60
F-550 Super Duty Cab & Chassis, w/34" Wide Frames	05-07	30	SQ4	2	41547		@		750/7,500	1,200/12,000	60
		50	SQ5	2	41947		@		1,600/15,000	1,600/16,000	35
		70	SQ5	2	41943		@		2,400/16,000	1,600/16,000	40
		65	SQ5	2-1/2	45516		#		1,200/12,000	1,700/14,000	60
F-550 Super Duty Cab & Chassis, w/34" Wide Frames	08-16	30	SQ4	2	41547		@		750/7,500	1,200/12,000	60
		50	SQ5	2	41947		@		1,600/15,000	1,600/16,000	35
		70	SQ5	2	41943		@		2,400/16,000	1,600/16,000	40
		65	SQ5	2-1/2	45516		#		1,200/12,000	1,700/14,000	60
Fiesta 4 Dr. Sedan	11-13	37	SQ1	1-1/4	24856	0	HM	3593	200/2,000		15
Fiesta 5 Dr. Hatchback	11-13	25	SQ1	1-1/4	24855	0	HM,JR,KH	3593	200/2,000		30
Fiesta 4 Dr. Sedan	14-16	31	SQ1	1-1/4	24910	0	HM	3593	200/2,000		15
Fiesta 5 Dr. Hatchback	14-16	25	SQ1	1-1/4	24855	0	HM,JR,KH	3593	200/2,000		30
Five Hundred	05-07	33	SQ2	1-1/4	36360	0	GP,JR	36071	300/3,500		30
		42	SQ3	2	75299	0	JR		350/3,500	400/4,000	30
Flex	09-11	45	RT3	2	75679	0	HM,JR		400/4,000	400/4,000	30
Flex w/Factory 7-Way	09-12										
Flex	12-16	45	RT3	2	75679	0	HM,JR		400/4,000	400/4,000	30
Focus Sedan	00-00	24	SQ1	1-1/4	24692	0	HM	3593	200/2,000		20
Focus Wagon (Built Before 11/2002)	00-03	33	SQ1	1-1/4	24682	0	JR,GP	3592	200/2,000		20
Focus Sedan	01-04	24	SQ1	1-1/4	24692	0	HM	3593	200/2,000		20
Focus Wagon (Built After 11/2002)	03-07	33	SQ1	1-1/4	24682	0	JR,GP	3592	200/2,000		20
Focus Sedan, Except w/Street Appearance Pkg.	05-07	24	SQ1	1-1/4	24692	0	HM	3593	200/2,000		20
Focus	08-11	33	SQ1	1-1/4	24805	0	HM,JR,KH	3593	200/2,000		30
Focus 5 Dr. Hatchback, Except ST w/Center Exhaust	12-14	18	SQ1	1-1/4	24872	0	GP,JR,KH	3593	200/2,000		25
Focus Sedan	12-16	18	SQ1	1-1/4	24872	0	GP,JR,KH	3593	200/2,000		25
Focus 5 Dr. Hatchback	13-16										
Focus 5 Dr. Hatchback, Except ST w/Center Exhaust & RS Models	15-16	18	SQ1	1-1/4	24872	0	GP,JR,KH	3593	200/2,000		25
Focus ZX3 3 Dr. Hatchback, Except SVT & w/Street Appearance Pkg.	00-06	24	SQ1	1-1/4	24692		HM	3593	200/2,000		20
Focus ZX5 5 Dr. Hatchback, Except SVT & w/Street Appearance Pkg.	02-06	24	SQ1	1-1/4	24692		HM	3593	200/2,000		20
Freestar	04-07	41	SQ2	1-1/4	36318	0	GP,JR	36071	300/3,500		25
		45	SQ3	2	75158		GP,JR		350/3,500	500/5,000	30
Freestyle	05-07	33	SQ2	1-1/4	36360	0	GP,JR	36071	300/3,500		30
		42	SQ3	2	75299	0	JR		350/3,500	400/4,000	30

- # Titan hitches require use of a 2-1/2" shank Titan ball mount.
- @ Ultra Frame ball mount must be used to achieve maximum weight carrying rating.
- CS Will fit with full-size spare tire stowed under vehicle.
- EF Fits all models with standard bumpers.
- GP Hitch crosstube concealed behind bumper.

- HM Hitch crosstube is visible beneath bumper.
- JR Exhaust must be temporarily lowered for installation.
- KH Minor heat shield modification may be required.
- LT Requires removal of factory hitch if equipped.
- M Will fit with heavy-duty suspension.

RECEIVER HITCH APPLICATION GUIDE

T-ONE						TOW HARNESS						4-FLAT WIRING				REQ. 4 FLAT WIRING			BRAKE CONTROL HARNESS	IN	
PC	T-ONE	FN	IN	AMP	CP	PC	TOW HARN	FN	IN	AMP	CP	TYPE	ELEC	POS	CHOICE 1	CHOICE 2	6-WAY ADAPTER	7-WAY ADAPTER			7-WAY HARDWIRE
FORD (Continued)																					
													A	PU1,2	119180	20252	20320	20321	20224	3065-P	5
													A	PU1,2	119180	20252	20320	20321	20224	3034-P	20
													A	PU1,2	119180	20252	20320	20321	20224	3034-P	20
							20119 118015	RD RD	10 10			Both 7-Way	A	PU3	119180	20252					
													A	PU1,2	119180	20252	20320	20321	20224	3034-P	20
													A	PU1,2	119180	20252	20320	20321	20224	3035-P	5
													A	PU1,2	119180	20252	20320	20321	20224	3065-P	5
													A	PU1,2	119180	20252	20320	20321	20224	3034-P	20
E14	118422	CH	30	2.1,4.2	X								A,E	PC3,4	119148	119180					
E18	118471	CH	45	2.1,5.6	X								B,E	PC3,4	119148	119180					
													A,E	PC3,4	119148	119180					
E15	118641	CH	45	2.1,5.6	X								B,E	PC3,4	119148	119180					
E5	118395		10	7.5									A	PC3,4	119180	20252	20320	20321	20224		
E8	118472		15	7.5									A	SUV1,2	119180	20252	20320	20321	20224	3035-P	5
							20119 118015	RD RD	10 10			Both 7-Way	A	SUV6	119180	20252					
E8	118472		15	7.5									A	SUV1,2	119180	20252	20320	20321	20224	3036-P	20
													B	PC3,4	119130	119178					
E5	118344	FW	10	7.5									A	PC1,2	119180	20252					
													C	PC3,4	119180	119148					
													A	PC1,2	119180	20252					
													A	PC3,4	119180	20252					
E5	118457	BN	15	7.5									A	PC1,2	119180	20252					
E18	118549	CH	45	2.1,5.6	X								B,E	PC1,2	119148	119180					
E16	118548	CH	45	2.1,5.6	X								B,E	PC3,4	119148	119180					
E18	118549	CH	45	2.1,5.6	X								B,E	PC1,2	119148	119180					
E18	118674	CH	45	4.2,7.5	X								B,E	PC1,2	119148	119180					
													A	PC1,2	119180	20252					
													A	PC1,2	119180	20252					
E17	118385	CH	45	2.1,5.6	X								N	SUV1,2		119251	20320	20321			
E5	118395		10	7.5									A	SUV3,4	119180	20252	20320	20321	20224		

- A** 2 wire system.
- B** 3 wire system. Converter required.
- BN** Exterior mounted plug on some or all models. May require an aftermarket electrical mounting box or bracket. (Sold separately)
- C** 2 or 3 wire system determine at installation.
- CH** T-One is equipped with circuit protected ModuLite® module.
- E** ModuLite® required.
- FW** 2003 Models w/Build date before 11/1/02.
- N** DO NOT cut or splice vehicle wiring. Only use approved T-One or see auto dealer for trailer tow wiring kit.
- RD** For vehicles equipped with factory tow package may require additional components or may be used as a replacement harness.

- RT3** Round Tube Class II 2"
- SQ1** Square Tube Class I
- SQ2** Square Tube Class II
- SQ3** Square Tube Class III
- SQ4** Square Tube Class IV
- SQ5** Square Tube Class V

RECEIVER HITCH APPLICATION GUIDE

MODEL / STYLE	YEAR	TRAILER HITCHES									
		PC	REC TYPE	REC SIZE	PART #	NO DRILL	FOOTNOTES	OPTIONAL DRAWBAR	WC (LBS.)	WD (LBS.)	IN
FORD (Continued)											
Fusion	06-09	39	SQ1	1-1/4	24775		GP, JR, TA	3592	200/2,000		45
Fusion	10-12	25	SQ1	1-1/4	24865	0	GP, JR	3594	200/2,000		20
Fusion Except Sport	13-17	19	SQ1	1-1/4	24897	0	HM, SV	3594	200/2,000		20
Mustang	94-98	29	SQ1	1-1/4	24687		RB, GP	3592	200/2,000		20
Mustang Except Cobra SVT	99-04	29	SQ1	1-1/4	24687		RB, GP	3592	200/2,000		20
Mustang Except GT/CS (California Special)/Shelby GT/GT500	05-09	22	SQ1	1-1/4	24747		GP, JR	3592	200/2,000		45
Mustang Except GT/CS (California Special)/Shelby GT/GT500	10-10	23	SQ1	1-1/4	24840†		†, GP, JR, X	3592	200/2,000		45
Mustang V6 Models	11-14	24	SQ1	1-1/4	24863	0	HM, JR	3594	200/2,000		40
Mustang V8 Models	11-14	24	SQ1	1-1/4	24863	0	GP, HB, JR	3594	200/2,000		40
Mustang	15-17	43	SQ1	1-1/4	24928	0	HM, JR, AI	3594	200/2,000		30
Ranger	93-97	24	SQ3	2	75082		EG, SD, V		400/4,000	750/6,000	20
Ranger Except w/Rear Fascia	93-97	50	SQ3	2	37136	0			500/5,000	600/6,000	40
Ranger	98-98	24	SQ3	2	75082		SD, V		400/4,000	750/6,000	20
Ranger Except Flareside or w/Rear Fascia	98-99	50	SQ3	2	37136	0			500/5,000	600/6,000	40
Ranger	99-99	24	SQ3	2	75082		SD, V		400/4,000	750/6,000	20
Ranger	00-03	24	SQ3	2	75082		SD, V		400/4,000	750/6,000	20
Ranger Except Flareside or w/Rear Fascia	00-03	50	SQ3	2	37136	0			500/5,000	600/6,000	40
Ranger w/Factory 7-Way	00-11										
Ranger	04-11	24	SQ3	2	75082		SD, V		400/4,000	750/6,000	20
Ranger Except Flareside or w/Rear Fascia	04-11	50	SQ3	2	37136	0			500/5,000	600/6,000	40
Ranger	13-16	54	RT3	2	75790	0	HM, CS		600/4,000	600/6,000	30
Taurus 4 Dr. Sedan, Except SHO	96-99	35	SQ1	1-1/4	24699	0	GP, JR	3593	200/2,000		20
		35	SQ2	1-1/4	36252	0	GP, JR	36063	300/3,500		20
Taurus SHO	96-99	35	SQ2	1-1/4	36252	0	GP, JR	36063	300/3,500		20
Taurus Wagon	96-99	35	SQ1	1-1/4	24699	0	GP, JR	3593	200/2,000		20
		35	SQ2	1-1/4	36252	0	GP, JR	36063	300/3,500		20
Taurus 4 Dr. Sedan	00-03	35	SQ1	1-1/4	24699	0	GP, JR	3592	200/2,000		20
		35	SQ2	1-1/4	36252	0	GP, JR	36063	300/3,500		20
		47	SQ2	1-1/4	36313	0	GP, JR	36061	300/3,500		40
Taurus Wagon	00-03	35	SQ1	1-1/4	24699	0	GP, JR	3592	200/2,000		20
		35	SQ2	1-1/4	36252	0	GP, JR	36063	300/3,500		20
		47	SQ2	1-1/4	36313	0	GP, JR	36061	300/3,500		40
Taurus 4 Dr. Sedan	04-06	47	SQ2	1-1/4	36313	0	GP, JR	36061	300/3,500		40
Taurus Wagon	04-06	47	SQ2	1-1/4	36313	0	GP, JR	36061	300/3,500		40
Taurus 4 Dr. Sedan	08-09	33	SQ2	1-1/4	36360	0	GP, JR	36071	300/3,500		30
		42	SQ3	2	75299	0	JR		350/3,500	400/4,000	30
Taurus 4 Dr. Sedan	10-16	36	SQ2	1-1/4	36492		GP, JR	36071	300/3,500		30
		45	SQ3	2	75670		GP, JR		400/4,000	400/4,000	30
Taurus X	08-09	33	SQ2	1-1/4	36360	0	GP, JR	36071	300/3,500		30
		42	SQ3	2	75299	0	JR		350/3,500	400/4,000	30
Thunderbird	96-97	41	SQ2	1-1/4	36179	0	GP	36063	300/3,500		40
Transit Connect	10-13	33	RT3	2	75678	0			350/3,500	400/4,000	20
Transit Connect	14-16	32	RT3	2	75852	0	HM		400/3,500	400/4,000	15
Transit-150 Except Cab & Chassis and the Cutaway	15-17	27	RT3	2	75912	0	HM		750/5,000	800/8,000	25
Transit-250 Except Cab & Chassis and the Cutaway	15-17	27	RT3	2	75912	0	HM		750/5,000	800/8,000	25
Transit-350 Except Cab & Chassis and the Cutaway	15-17	27	RT3	2	75912	0	HM		750/5,000	800/8,000	25
Windstar	95-98	30	SQ2	1-1/4	36189		GP	36061	300/3,500		30
		43	SQ3	2	75055		GP		350/3,500	500/5,000	40
Windstar (Built Before 11/2002)	99-03	30	SQ2	1-1/4	36189		GP	36061	300/3,500		30
		43	SQ3	2	75055		GP		350/3,500	500/5,000	40
		50	SQ3	2	37136	0	AF		500/5,000	600/6,000	40

- † Available while supply lasts.
- AF Hitch is ONLY rated for Weight Carrying at 3500 lbs. GTW / 350 lbs. TW and DO NOT use Weight Distribution Spring Bars for this Specific Vehicle. Except for long bed pickups.
- AI Additional installation time may be required.
- CS Will fit with full-size spare tire stowed under vehicle.
- EG Relocation of spare tire bracket is not required. NOTE: 19mm open end style wrench must be purchased to allow removal of spare tire after hitch installation.
- GP Hitch crosstube concealed behind bumper.
- HB Slight fascia deformation may occur on some models.
- HM Hitch crosstube is visible beneath bumper.

- JR Exhaust must be temporarily lowered for installation.
- RB Hitch installation can be made easier with a "cutter" type drill bit.
- SD Hitches produced before 07/21/06 are rated at 350/3500 WC.
- SV Trimming or removal of under body appearance panel may be required.
- TA Trunk access required for hitch installation.
- V For vehicles with factory installed step bumpers only.
- X Minor fascia trimming required.

RECEIVER HITCH APPLICATION GUIDE

PC	T-ONE					TOW HARNESS						4-FLAT WIRING				REQ. 4 FLAT WIRING		BRAKE CONTROL HARNESS	IN
	T-ONE	FN	IN	AMP	CP	TOW HARN	FN	IN	AMP	CP	TYPE	ELEC	POS	CHOICE 1	CHOICE 2	6-WAY ADAPTER	7-WAY ADAPTER		
FORD (Continued)																			
E14	118422	CH	30	2.1,4.2	X							A,E	PC3,4	119148	119180				
E14	118422	CH	30	2.1,4.2	X							A,E	PC3,4	119148	119180				
E16	118574	CH	45	2.1,5.6	X							A,E	PC1,2	119148	119180				
E9	118326		20	7.5								A	PC3,4	119180	20252				
E9	118326		20	7.5								A	PC3,4	119180	20252				
E16	118487	CH	45	2.1,5.6	X							A,E	PC3,4	119148	119180				
E16	118487	CH	45	2.1,5.6	X							A,E	PC3,4	119148	119180				
E16	118487	CH	45	2.1,5.6	X							A,E	PC3,4	119148	119180				
E16	118487	CH	45	2.1,5.6	X							A,E	PC3,4	119148	119180				
E9	118325	BN,HG	5	2.1,5								B	PU3	119130	119178	20320	20321	20224	
E9	118325	BN,HG	5	2.1,5								B	PU3	119130	119178	20320	20321	20224	
E9	118325	BN,HG	5	2.1,5		E2	118241	BN,RD	5	7.5	4-Flat	B	PU3	119130	119178	20320	20321	20224	
E9	118325	BN,HG	5	2.1,5		E2	118241	BN,RD	5	7.5	4-Flat	B	PU3	119130	119178	20320	20321	20224	
E9	118325	BN,HG	5	2.1,5		E2	118241	BN,RD	5	7.5	4-Flat	B	PU3	119130	119178	20320	20321	20224	
E5	118344	BN	10	7.5								A	PU1,2	119180	20252	20320	20321	20224	
E5	118344	BN	10	7.5								A	PU1,2	119180	20252	20320	20321	20224	
							20119 118015	RD RD	10 10		Both 7-Way	A	PU5	119180	20252			20224	
												A	PU1,2	119180	20252	20320	20321	20224	
												A	PU1,2	119180	20252	20320	20321	20224	
												B,E	PU3,4	119148	119180	20320	20321		
E9	118333	HG	10	2.1,5								B	PC3,4	119130	119178				
E9	118333	HG	10	2.1,5								B	PC3,4	119130	119178				
												B	PC3,4	119130	119178				
E4	118375		10	7.5								A	PC3,4	119180	20252				
												C	PC3,4	119180	119148				
												A	PC3,4	119180	20252				
												A	PC3,4	119180	20252				
E7	118447		10	7.5								A	PC3,4	119180	20252	20320	20321	20224	
E15	118599	CH	45	2.1,5.6	X							B,E	PC3,4	119148	119180	20320	20321	20224	
E7	118448		15	7.5								A	SUV3,4	119180	20252	20320	20321	20224	
												A,E	PC3,4	119148	119180				
E26	118585	BN,CH	45	4.2,7.5	X							B,E	SUV1,2	119148	119180	20320	20321	20224	
E14	118613	BN,CH	45	4.2,7.5	X							B,E	SUV3,4	119148	119180	20320	20321	20224	
E16	118643	CH	45	4.2,7.5	X		22114		60		7-Way	A,E	SUV1,2	119148	119180	20320	20231	20224	
E16	118643	CH	45	4.2,7.5	X		22114		60		7-Way	A,E	SUV1,2	119148	119180	20320	20231	20224	
E18	118722	BN,CH	45	5,7.5	X							A,E	SUV1,2	119148	119180	20320	20231	20224	
		HG										B	SUV1,2	119130	119178	20320	20321	20224	3035-P 5
E19	118366	FW,LS	45	2.1,4.2								G	SUV1,2		119251	20320	20321		3035-P 5

- A** 2 wire system.
- B** 3 wire system. Converter required.
- BN** Exterior mounted plug on some or all models. May require an aftermarket electrical mounting box or bracket. (Sold separately)
- C** 2 or 3 wire system determine at installation.
- CH** T-One is equipped with circuit protected ModuLite® module.
- E** ModuLite® required.
- FW** 2003 Models w/Build date before 11/1/02.
- G** Low-side switching system.
- HG** T-One incorporates taillight converter.
- LS** T-One incorporates low-side switching taillight converter. Additional installation time required.
- RD** For vehicles equipped with factory tow package may require additional components or may be used as a replacement harness.

- RT3** Round Tube Class III 2"
- SQ1** Square Tube Class I
- SQ2** Square Tube Class II
- SQ3** Square Tube Class III

RECEIVER HITCH APPLICATION GUIDE

MODEL / STYLE	YEAR	TRAILER HITCHES									
		PC	REC TYPE	REC SIZE	PART #	NO DRILL	FOOTNOTES	OPTIONAL DRAWBAR	WC (LBS.)	WD (LBS.)	IN
FORD (Continued)											
Windstar (Built After 11/2002)	03-03	30	SQ2	1-1/4	36189		GP	36061	300/3,500		30
		43	SQ3	2	75055		GP		350/3,500	500/5,000	40
		50	SQ3	2	37136	0	AF		500/5,000	600/6,000	40
FREIGHTLINER											
Sprinter 2500 w/41" Wide Frames, Except 118" Wheelbase & Factory Metal Step Platform	03-06	48	SQ3	2	75210	0	HM		500/5,000	750/7,500	20
Sprinter 2500 w/41" Wide Frames, Except 118" Wheelbase & Factory Metal Step Platform, w/Factory 7-Way	03-06										
Sprinter 2500 144" & 170" Wheelbase, Except w/Factory Step Bumper	07-09	53	SQ4	2	75549	0	HM,UL		600/6,000	750/7,500	20
Sprinter 2500 144" & 170" Wheelbase, Except w/Factory Step Bumper, w/Factory 7-Way	07-09										
Sprinter 2500 w/Factory Step Bumper Excluding Models w/30-3/8" Frame Width	07-09	52	SQ3	2	75601	0	HM		500/5,000	750/7,500	30
Sprinter 2500 w/Factory Step Bumper, w/Factory 7-Way	07-09										
Sprinter 2500 144" & 170" Wheelbase, Except w/Factory Step Bumper	10-12	53	SQ4	2	75549	0	HM,UL		600/6,000	750/7,500	20
Sprinter 2500 w/Factory Step Bumper Excluding Models w/30-3/8" Frame Width	10-12	52	SQ3	2	75601	0	HM		500/5,000	750/7,500	30
Sprinter 2500 144" & 170" Wheelbase, Except w/Factory Step Bumper	13-13	53	SQ4	2	75549	0	HM,UL		600/6,000	750/7,500	20
Sprinter 2500 w/Factory Step Bumper Excluding Models w/30-3/8" Frame Width	13-13	52	SQ3	2	75601	0	HM		500/5,000	750/7,500	30
Sprinter 3500 w/41" Wide Frames, Except 118" Wheelbase & Factory Metal Step Platform	03-06	48	SQ3	2	75210	0	HM		500/5,000	750/7,500	20
Sprinter 3500 w/41" Wide Frames, Except 118" Wheelbase & Factory Metal Step Platform, w/Factory 7-Way	03-06										
Sprinter 3500 144" & 170" Wheelbase, Except w/Factory Step Bumper	07-09	53	SQ4	2	75549	0	HM,UL		600/6,000	750/7,500	20
Sprinter 3500 144" & 170" Wheelbase, Except w/Factory Step Bumper, w/Factory 7-Way	07-09										
Sprinter 3500 w/Factory Step Bumper Excluding Models w/30-3/8" Frame Width	07-09	52	SQ3	2	75601	0	HM		500/5,000	750/7,500	30
Sprinter 3500 w/Factory Step Bumper, w/Factory 7-Way	07-09										
Sprinter 3500 144" & 170" Wheelbase, Except w/Factory Step Bumper	10-12	53	SQ4	2	75549	0	HM,UL		600/6,000	750/7,500	20
Sprinter 3500 w/Factory Step Bumper Excluding Models w/30-3/8" Frame Width	10-12	52	SQ3	2	75601	0	HM		500/5,000	750/7,500	30
Sprinter 3500 144" & 170" Wheelbase, Except w/Factory Step Bumper	13-13	53	SQ4	2	75549	0	HM,UL		600/6,000	750/7,500	20
Sprinter 3500 w/Factory Step Bumper Excluding Models w/30-3/8" Frame Width	13-13	52	SQ3	2	75601	0	HM		500/5,000	750/7,500	30
GEO											
Prizm	93-97	25	SQ1	1-1/4	24579		GP	3593	200/2,000		30
Tracker	96-97	25	SQ1	1-1/4	24622	0	HM	3593	200/2,000		20
GMC											
Acadia	07-12	19	RT3	2	75528	0	GP,JR,TN		750/5,000	750/7,500	25
Acadia w/Factory 7-Way	07-12										
Acadia	13-16	19	RT3	2	75528	0	GP,JR,TN		750/5,000	750/7,500	25
Acadia	17-17	24	SQ3	2	76023	0	GP,JR,AA,DU,SV,TA		675/4,500	675/4,500	90

- AA** Requires temporary removal of bumper during installation.
- AF** Hitch is ONLY rated for Weight Carrying at 3500 lbs. GTW / 350 lbs. TW and DO NOT use Weight Distribution Spring Bars for this Specific Vehicle. Except for long bed pickups.
- DU** Fascia removal required.
- GP** Hitch crosstube concealed behind bumper.
- HM** Hitch crosstube is visible beneath bumper.

- JR** Exhaust must be temporarily lowered for installation.
- SV** Trimming or removal of under body appearance panel may be required.
- TA** Trunk access required for hitch installation.
- TN** Hitches produced before 07/09/12 are rated at 500/5000 WC & 500/5000 WD.
- UL** This hitch will not fit a Sprinter single or dual rear-wheel vehicle with a 30-3/8" wide frame measured outside of frame to outside of frame.

RECEIVER HITCH APPLICATION GUIDE

T-ONE						TOW HARNESS						4-FLAT WIRING				REQ. 4 FLAT WIRING		7-WAY HARDWIRE	BRAKE CONTROL HARNESS	IN	
PC	T-ONE	FN	IN	AMP	CP	PC	TOW HARN	FN	IN	AMP	CP	TYPE	ELEC	POS	CHOICE 1	CHOICE 2	6-WAY ADAPTER				7-WAY ADAPTER
FORD (Continued)																					
E19	118305	FV,LS	45	2,1,4,2									G	SUV1,2		119251	20320	20321		3035-P	5
FREIGHTLINER																					
						E3	118381	BN,RD	5	7.5		4-Flat	B,E	SUV3,4	119180	20252	20320	20321	20224		
							20135	RD	10			Both	H	SUV6	119180	20252					
E17	118650	CH	45	5,7,5	X	E3	118381	BN,RD	5	7.5		4-Flat	B,E	SUV1,2	119148	119180	20320	20321	20224		
							20135	RD	10			Both	H	SUV6	119180	20252					
E17	118650	CH	45	5,7,5	X	E3	118381	BN,RD	5	7.5		4-Flat	B,E	SUV1,2	119148	119180	20320	20321	20224		
							20135	RD	10			Both	H	SUV6	119180	20252					
E17	118650	CH	45	5,7,5	X								B,E	SUV1,2	119148	119180	20320	20321	20224		
E17	118650	CH	45	5,7,5	X								B,E	SUV3,4	119192	119191	20320	20321	20224		
E17	118650	CH	45	5,7,5	X								B,E	SUV3,4	119192	119191	20320	20321	20224		
						E3	118381	BN,RD	5	7.5		4-Flat	B,E	SUV3,4	119148	119180	20320	20321	20224		
							20135	RD	10			Both	H	SUV6	119180	20252					
E17	118650	CH	45	5,7,5	X	E3	118381	BN,RD	5	7.5		4-Flat	B,E	SUV1,2	119148	119180	20320	20321	20224		
							20135	RD	10			Both	H	SUV6	119180	20252					
E17	118650	CH	45	5,7,5	X								B,E	SUV1,2	119148	119180	20320	20321	20224		
E17	118650	CH	45	5,7,5	X								B,E	SUV1,2	119148	119180	20320	20321	20224		
E17	118650	CH	45	5,7,5	X								B,E	SUV3,4	119251	119191	20320	20321	20224		
E17	118650	CH	45	5,7,5	X								B,E	SUV3,4	119251	119191	20320	20321	20224		
GEO																					
													B	PC3,4	119130	119178					
E5	118372	HG	5	2,1,5									B	SUV1,2	119130	119178					
GMC																					
E11	118451	BN	15	7.5		E8	118384	BN,RD	5	7.5		4-Flat	N	SUV1,2		119251	20320	20321		3026-P	5
							20047	RD	5			7-Way	N	SUV6		119251					
							20119	RD	10			Both									
							118015	RD	10			7-Way									
E10	118270	BN	20	7.5		E16	118271	BN	20			7-Way	A,E	SUV1,2	119148	119180	20320	20321	20224	3026-P	5
E3	118720	BN	10			E9	118276	BN	10				A	SUV6	119180	20252					

- A** 2 wire system.
- B** 3 wire system. Converter required.
- BN** Exterior mounted plug on some or all models. May require an aftermarket electrical mounting box or bracket. (Sold separately)
- CH** T-One is equipped with circuit protected ModuLite® module.
- E** ModuLite® required.
- FV** 2003 Models w/Build date after 11/1/02.
- G** Low-side switching system.
- H** 3 wire system with OEM standard 2 wire harness.
- HG** T-One incorporates taillight converter.
- LS** T-One incorporates low-side switching taillight converter. Additional installation time required.
- N** DO NOT cut or splice vehicle wiring. Only use approved T-One or see auto dealer for trailer tow wiring kit.
- RD** For vehicles equipped with factory tow package may require additional components or may be used as a replacement harness.

- RT3** Round Tube Class III 2"
- SQ1** Square Tube Class I
- SQ2** Square Tube Class II
- SQ3** Square Tube Class III
- SQ4** Square Tube Class IV

RECEIVER HITCH APPLICATION GUIDE

MODEL / STYLE	YEAR	TRAILER HITCHES									
		PC	REC TYPE	REC SIZE	PART #	NO DRILL	FOOTNOTES	OPTIONAL DRAWBAR	WC (LBS.)	WD (LBS.)	IN
GMC (Continued)											
C1500 w/34" Wide Frames	85-99	50	SQ5	2	41938		@,CC		1,200/12,000	1,500/15,000	40
		50	SQ5	2	41947		@		1,600/15,000	1,600/16,000	35
C1500	88-99	49	RT3	2	37133				500/5,000	750/7,500	40
		35	SQ3	2	75033	0	HM,J		500/5,000	800/8,000	20
		25	SQ3	2	75099	0	GP		500/5,000	800/8,000	20
		30	SQ4	2	40050		HC		600/6,000	1,000/10,000	40
		44	SQ4	2	41524	0	GP		600/6,000	1,000/10,000	20
		38	SQ4	2	41525	0	HM,J		600/6,000	1,000/10,000	20
		54	RT4	2	37130				700/7,000	1,200/12,000	40
		45	SQ5	2	41901		@,DB,GP,SN		1,000/10,000	1,300/13,000	30
C1500 w/10" Deep Drop Bumper	88-99	53	SQ4	2	41528	0	FS,J		600/6,000	1,000/10,000	20
C1500 w/Aftermarket Roll Pan	88-99	38	SQ3	2	41522		CO,HK		500/5,000	550/5,500	40
C2500 w/34" Wide Frames	85-00	50	SQ5	2	41938		@,CC		1,200/12,000	1,500/15,000	40
		50	SQ5	2	41947		@		1,600/15,000	1,600/16,000	35
C2500	88-00	49	RT3	2	37133				500/5,000	750/7,500	40
		35	SQ3	2	75033	0	HM,J		500/5,000	800/8,000	20
		25	SQ3	2	75099	0	GP		500/5,000	800/8,000	20
		30	SQ4	2	40050		HC		600/6,000	1,000/10,000	40
		44	SQ4	2	41524	0	GP		600/6,000	1,000/10,000	20
		38	SQ4	2	41525	0	HM,J		600/6,000	1,000/10,000	20
		54	RT4	2	37130				700/7,000	1,200/12,000	40
		45	SQ5	2	41901		@,DB,GP,SN		1,000/10,000	1,300/13,000	30
59	SQ5	2-1/2	45506		#		1,200/12,000	1,700/14,000	45		
C2500 w/10" Deep Drop Bumper	88-00	53	SQ4	2	41528	0	FS,J		600/6,000	1,000/10,000	20
C2500 w/Aftermarket Roll Pan	88-00	38	SQ3	2	41522		CO,HK		500/5,000	550/5,500	40
C3500 w/34" Wide Frames	85-00	50	SQ5	2	41938		@,CC		1,200/12,000	1,500/15,000	40
		50	SQ5	2	41947		@		1,600/15,000	1,600/16,000	35
C3500	88-00	49	RT3	2	37133				500/5,000	750/7,500	40
		35	SQ3	2	75033	0	HM,J		500/5,000	800/8,000	20
		25	SQ3	2	75099	0	GP		500/5,000	800/8,000	20
		30	SQ4	2	40050		HC		600/6,000	1,000/10,000	40
		44	SQ4	2	41524	0	GP		600/6,000	1,000/10,000	20
		38	SQ4	2	41525	0	HM,J		600/6,000	1,000/10,000	20
		54	RT4	2	37130				700/7,000	1,200/12,000	40
		45	SQ5	2	41901		@,DB,GP,SN		1,000/10,000	1,300/13,000	30
59	SQ5	2-1/2	45506		#		1,200/12,000	1,700/14,000	45		
C3500 w/10" Deep Drop Bumper	88-00	53	SQ4	2	41528	0	FS,J		600/6,000	1,000/10,000	20
C3500 w/Aftermarket Roll Pan	88-00	38	SQ3	2	41522		CO,HK		500/5,000	550/5,500	40
C4500 Topkick Cab & Chassis, w/34" Wide Frames	03-09	50	SQ5	2	41947		@		1,600/15,000	1,600/16,000	35
C5500 Topkick Cab & Chassis, w/34" Wide Frames	03-09	50	SQ5	2	41947		@		1,600/15,000	1,600/16,000	35
C6500 Topkick Cab & Chassis, w/34" Wide Frames	99-09	50	SQ5	2	41947		@		1,600/15,000	1,600/16,000	35
C7500 Topkick Cab & Chassis, w/34" Wide Frames	99-09	50	SQ5	2	41947		@		1,600/15,000	1,600/16,000	35
Canyon	04-12	23	SQ4	2	75607	0	CP,GP		600/6,000	750/7,500	25
Canyon w/Factory 7-Way	04-12										
Canyon	15-16	34	RT4	2	75948	0	HM,AA,V,SO,TZ		800/6,000	800/8,000	35
		30	SQ4	2	76004	0	HM,AA,V,SO,TZ		800/8,000	1,000/10,000	35
Envoy w/Factory 7-Way	02-09										

- # Titan hitches require use of a 2-1/2" shank Titan ball mount.
- @ Ultra Frame ball mount must be used to achieve maximum weight carrying rating.
- AA Requires temporary removal of bumper during installation.
- CC Requires minimum of 19" from end of frame rail to spring shackle bracket.
- CO Will not fit 8 ft. 2500/3500 Series with heavy-duty suspension or four door Crew Cab.
- CP Fits all models without factory installed receiver.
- DB Will not fit 6 ft. bed pickups.
- FS Includes 2 & 4 WD models with heavy duty suspension.
- GP Hitch crosstube concealed behind bumper.
- HC Will not fit with mini or full size tire stowed under vehicle.
- HK Under vehicle spare tire storage may be retained with installation of an aftermarket spare tire repositioner. Cutting of rollpan in license plate area required for receiver tube access. Does not fit with bumper.
- HM Hitch crosstube is visible beneath bumper.
- J Under vehicle spare tire storage is retained.
- SN Hitches produced before 04/28/08 are rated at 1000/10000 WC & 1200/12000 WD.
- SO With this hitch installed the step bumper is no longer able to be used as a towing point.
- TZ Requires replacement of the impact structure with hitch.
- V For vehicles with factory installed step bumpers only.

RECEIVER HITCH APPLICATION GUIDE

T-ONE						TOW HARNESS						4-FLAT WIRING				REQ. 4 FLAT WIRING		7-WAY HARDWIRE	BRAKE CONTROL HARNESS	IN
PC	T-ONE	FN	IN	AMP	CP	PC	TOW HARN	FN	IN	AMP	CP	TYPE	ELEC	POS	CHOICE 1	CHOICE 2	6-WAY ADAPTER			
GMC (Continued)																				
													A	PU1,2	119180	20252	20320	20321	20224	
E3	118315	BN	5	7.5									A	PU3	119180	20252	20320	20321	20224	
E3	118315	BN	5	7.5									A	PU3	119180	20252	20320	20321	20224	
E3	118315	BN	5	7.5									A	PU1,2	119180	20252	20320	20321	20224	
E3	118315	BN	5	7.5									A	PU3	119180	20252	20320	20321	20224	
E3	118315	BN	5	7.5									A	PU3	119180	20252	20320	20321	20224	
E3	118315	BN	5	7.5									A	PU3	119180	20252	20320	20321	20224	
													A	PU1,2	119180	20252	20320	20321	20224	
E3	118315	BN	5	7.5									A	PU3	119180	20252	20320	20321	20224	
E3	118315	BN	5	7.5									A	PU3	119180	20252	20320	20321	20224	
													A		119180	20252				
													A		119180	20252				
													A		119180	20252				
E10	118301	BN,CG	10	2.1,5	X								B	PU3	119130	119178	20320	20321	20224	
							20119	RD	10				H	PU3	119180	20252				
							20047	RD	5											
							118015	RD	10											
													A	PU3	119180	20252	20320	20321	20224	
						E8	118384	BN,RD	5	7.5		4-Flat	H	SUV6	119180	20252				
							20119	RD	10			Both								
							20047	RD	5			7-Way								
							118015	RD	10			7-Way								

A 2 wire system.
B 3 wire system. Converter required.
BN Exterior mounted plug on some or all models. May require an aftermarket electrical mounting box or bracket. (Sold separately)
CG T-One incorporates circuit protected taillight converter.
H 3 wire system with OEM standard 2 wire harness.
RD For vehicles equipped with factory tow package may require additional components or may be used as a replacement harness.

RT3 Round Tube Class III 2"
RT4 Round Tube Class IV 2"
SQ3 Square Tube Class III
SQ4 Square Tube Class IV
SQ5 Square Tube Class V

RECEIVER HITCH APPLICATION GUIDE

MODEL / STYLE	YEAR	TRAILER HITCHES									
		PC	REC TYPE	REC SIZE	PART #	NO DRILL	FOOTNOTES	OPTIONAL DRAWBAR	WC (LBS.)	WD (LBS.)	IN
GMC (Continued)											
Jimmy Downsize	95-98	32	SQ2	1-1/4	36244	0	FP,GP,KK	36051	300/3,500		15
		21	RT3	2	75079	0	FP,KK,SD		400/4,000	600/6,000	15
Jimmy Downsize	99-01	32	SQ2	1-1/4	36244	0	FP,GP,KK	36051	300/3,500		15
		21	RT3	2	75079	0	FP,KK,SD		400/4,000	600/6,000	15
Jimmy Downsize, w/Factory 7-Way	99-01										
Jimmy Downsize	02-05	32	SQ2	1-1/4	36244	0	FP,GP,KK	36051	300/3,500		15
		21	RT3	2	75079	0	FP,KK,SD		400/4,000	600/6,000	15
K1500	88-99	49	RT3	2	37133				500/5,000	750/7,500	40
		35	SQ3	2	75033	0	HM,J		500/5,000	800/8,000	20
		25	SQ3	2	75099	0	GP		500/5,000	800/8,000	20
		44	SQ4	2	41524	0	GP		600/6,000	1,000/10,000	20
		38	SQ4	2	41525	0	HM,J		600/6,000	1,000/10,000	20
		54	RT4	2	37130				700/7,000	1,200/12,000	40
		45	SQ5	2	41901		@,DB,GP,SN		1,000/10,000	1,300/13,000	30
K1500 w/10" Deep Drop Bumper	88-99	53	SQ4	2	41528	0	FS,J		600/6,000	1,000/10,000	20
K1500 w/34" Wide Frames	88-99	50	SQ5	2	41938		@,CC		1,200/12,000	1,500/15,000	40
		50	SQ5	2	41947		@		1,600/15,000	1,600/16,000	35
K1500 w/Aftermarket Roll Pan	88-99	38	SQ3	2	41522		CO,HK		500/5,000	550/5,500	40
K2500	88-00	49	RT3	2	37133				500/5,000	750/7,500	40
		35	SQ3	2	75033	0	HM,J		500/5,000	800/8,000	20
		25	SQ3	2	75099	0	GP		500/5,000	800/8,000	20
		44	SQ4	2	41524	0	GP		600/6,000	1,000/10,000	20
		38	SQ4	2	41525	0	HM,J		600/6,000	1,000/10,000	20
		54	RT4	2	37130				700/7,000	1,200/12,000	40
		45	SQ5	2	41901		@,DB,GP,SN		1,000/10,000	1,300/13,000	30
		59	SQ5	2-1/2	45506		#		1,200/12,000	1,700/14,000	45
K2500 w/10" Deep Drop Bumper	88-00	53	SQ4	2	41528	0	FS,J		600/6,000	1,000/10,000	20
K2500 w/34" Wide Frames	88-00	50	SQ5	2	41938		@,CC		1,200/12,000	1,500/15,000	40
		50	SQ5	2	41947		@		1,600/15,000	1,600/16,000	35
K2500 w/Aftermarket Roll Pan	88-00	38	SQ3	2	41522		CO,HK		500/5,000	550/5,500	40
K3500	88-00	49	RT3	2	37133				500/5,000	750/7,500	40
		35	SQ3	2	75033	0	HM,J		500/5,000	800/8,000	20
		25	SQ3	2	75099	0	GP		500/5,000	800/8,000	20
		44	SQ4	2	41524	0	GP		600/6,000	1,000/10,000	20
		38	SQ4	2	41525	0	HM,J		600/6,000	1,000/10,000	20
		54	RT4	2	37130				700/7,000	1,200/12,000	40
		45	SQ5	2	41901		@,DB,GP,SN		1,000/10,000	1,300/13,000	30
		59	SQ5	2-1/2	45506		#		1,200/12,000	1,700/14,000	45
K3500 w/10" Deep Drop Bumper	88-00	53	SQ4	2	41528	0	FS,J		600/6,000	1,000/10,000	20
K3500 w/34" Wide Frames	88-00	50	SQ5	2	41938		@,CC		1,200/12,000	1,500/15,000	40
		50	SQ5	2	41947		@		1,600/15,000	1,600/16,000	35
K3500 w/Aftermarket Roll Pan	88-00	38	SQ3	2	41522		CO,HK		500/5,000	550/5,500	40
Safari Extended Body	90-05	33	SQ2	1-1/4	36197	0	CS,HM	36051	300/3,500		30
		34	SQ2	1-1/4	36198	0	CS,GP		36053	300/3,500	
		33	SQ3	2	75122	0	CS,GP		300/3,500	600/6,000	30
		50	SQ3	2	37136		AF		500/5,000	600/6,000	65
Savana 1500	96-99	34	SQ2	1-1/4	36206	0	HM	36053	300/3,500		15
		50	SQ3	2	37136		HM		500/5,000	600/6,000	30
		22	SQ3	2	75189	0	HM		500/5,000	750/7,500	15
		33	SQ4	2	41521	0	HM		600/6,000	1,000/10,000	15
		42	SQ5	2	41946		@,HM		1,500/10,000	1,300/13,000	35

- # Titan hitches require use of a 2-1/2" shank Titan ball mount.
- @ Ultra Frame ball mount must be used to achieve maximum weight carrying rating.
- AF Hitch is ONLY rated for Weight Carrying at 3500 lbs. GTW / 350 lbs. TW and DO NOT use Weight Distribution Spring Bars for this Specific Vehicle. Except for long bed pickups.
- CC Requires minimum of 19" from end of frame rail to spring shackle bracket.
- CO Will not fit 8 ft. 2500/3500 Series with heavy-duty suspension or four door Crew Cab.
- CS Will fit with full-size spare tire stowed under vehicle.
- DB Will not fit 6 ft. bed pickups.
- FP Spare tire repositioning and/or modification of spare tire carrier may be required.

- FS Includes 2 & 4 WD models with heavy duty suspension.
- GP Hitch cross-tube concealed behind bumper.
- HK Under vehicle spare tire stowage may be retained with installation of an aftermarket spare tire repositioner. Cutting of rollpan in license plate area required for receiver tube access. Does not fit with bumper.
- HM Hitch cross-tube is visible beneath bumper.
- J Under vehicle spare tire stowage is retained.
- KK When installing on a vehicle originally equipped with an OEM hitch, OEM bumper brackets must be purchased and installed prior to new hitch installation.
- SD Hitches produced before 07/21/06 are rated at 350/3500 WC.
- SN Hitches produced before 04/28/08 are rated at 1000/10000 WC & 1200/12000 WD.

RECEIVER HITCH APPLICATION GUIDE

T-ONE						TOW HARNESS						4-FLAT WIRING				REQ. 4 FLAT WIRING		7-WAY HARDWIRE	BRAKE CONTROL HARNESS	IN	
PC	T-ONE	FN	IN	AMP	CP	PC	TOW HARN	FN	IN	AMP	CP	TYPE	ELEC	POS	CHOICE 1	CHOICE 2	6-WAY ADAPTER				7-WAY ADAPTER
GMC (Continued)																					
													A	SUV7	119180	20252	20320	20321	20224		
						E8	118384	BN,RD	5	7.5		4-Flat	A	SUV7	119180	20252	20320	20321	20224		
							20119 118015 20047	RD RD RD	10 10 5			Both 7-Way 7-Way	A	SUV6	119180	20252					
													A	SUV7	119180	20252	20320	20321	20224		
E3	118315	BN	5	7.5									A	PU3	119180	20252	20320	20321	20224		
E3	118315	BN	5	7.5									A	PU3	119180	20252	20320	20321	20224		
													A	PU1,2	119180	20252	20320	20321	20224		
E3	118315	BN	5	7.5									A	PU3	119180	20252	20320	20321	20224		
E3	118315	BN	5	7.5									A	PU3	119180	20252	20320	20321	20224		
E3	118315	BN	5	7.5									A	PU3	119180	20252	20320	20321	20224		
													A	PU1,2	119180	20252	20320	20321	20224		
E3	118315	BN	5	7.5									A	PU3	119180	20252	20320	20321	20224		
E3	118315	BN	5	7.5									A	PU3	119180	20252	20320	20321	20224		
E3	118315	BN	5	7.5									A	PU3	119180	20252	20320	20321	20224		
													A	PU1,2	119180	20252	20320	20321	20224		
E3	118315	BN	5	7.5									A	SUV4	119180	20252	20320	20321	20224		
E8	118335	HG	10	2.1.5		E1	118240	RD	5	7.5		4-Flat	B	SUV3,4	119130	119178	20320	20321	20224		

A 2 wire system.
B 3 wire system. Converter required.
BN Exterior mounted plug on some or all models. May require an aftermarket electrical mounting box or bracket. (Sold separately)

HG T-One incorporates taillight converter.
RD For vehicles equipped with factory tow package may require additional components or may be used as a replacement harness.

RT3 Round Tube Class III 2"
RT4 Round Tube Class IV 2"
SQ2 Square Tube Class II
SQ3 Square Tube Class III
SQ4 Square Tube Class IV
SQ5 Square Tube Class V

RECEIVER HITCH APPLICATION GUIDE

MODEL / STYLE	YEAR	TRAILER HITCHES									
		PC	REC TYPE	REC SIZE	PART #	NO DRILL	FOOTNOTES	OPTIONAL DRAWBAR	WC (LBS.)	WD (LBS.)	IN
GMC (Continued)											
Savana 1500	00-02	34	SQ2	1-1/4	36206	0	HM	36053	300/3,500		15
		50	SQ3	2	37136		HM		500/5,000	600/6,000	30
		22	SQ3	2	75189	0	HM		500/5,000	750/7,500	15
		33	SQ4	2	41521	0	HM		600/6,000	1,000/10,000	15
		42	SQ5	2	41946		@,HM		1,500/10,000	1,300/13,000	35
Savana 1500	03-03	34	SQ2	1-1/4	36206	0	HM	36053	300/3,500		15
		50	SQ3	2	37136		HM		500/5,000	600/6,000	30
		22	SQ3	2	75189	0	HM		500/5,000	750/7,500	15
		33	SQ4	2	41521	0	HM		600/6,000	1,000/10,000	15
		42	SQ5	2	41946		@,HM		1,500/10,000	1,300/13,000	35
Savana 1500	04-14	34	SQ2	1-1/4	36206	0	HM	36053	300/3,500		15
		50	SQ3	2	37136		HM		500/5,000	600/6,000	30
		22	SQ3	2	75189	0	HM		500/5,000	750/7,500	15
		33	SQ4	2	41521	0	HM		600/6,000	1,000/10,000	15
		42	SQ5	2	41946		@,HM		1,500/10,000	1,300/13,000	35
Savana 2500	96-99	34	SQ2	1-1/4	36206	0	HM	36053	300/3,500		15
		50	SQ3	2	37136		HM		500/5,000	600/6,000	30
		22	SQ3	2	75189	0	HM		500/5,000	750/7,500	15
		33	SQ4	2	41521	0	HM		600/6,000	1,000/10,000	15
		42	SQ5	2	41946		@,HM		1,500/10,000	1,300/13,000	35
		52	SQ5	2-1/2	45507	0	#,HM		1,200/12,000	1,700/14,000	45
Savana 2500	00-02	34	SQ2	1-1/4	36206	0	HM	36053	300/3,500		15
		50	SQ3	2	37136		HM		500/5,000	600/6,000	30
		22	SQ3	2	75189	0	HM		500/5,000	750/7,500	15
		33	SQ4	2	41521	0	HM		600/6,000	1,000/10,000	15
		42	SQ5	2	41946		@,HM		1,500/10,000	1,300/13,000	35
		52	SQ5	2-1/2	45507	0	#,HM		1,200/12,000	1,700/14,000	45
Savana 2500	03-03	34	SQ2	1-1/4	36206	0	HM	36053	300/3,500		15
		50	SQ3	2	37136		HM		500/5,000	600/6,000	30
		22	SQ3	2	75189	0	HM		500/5,000	750/7,500	15
		33	SQ4	2	41521	0	HM		600/6,000	1,000/10,000	15
		42	SQ5	2	41946		@,HM		1,500/10,000	1,300/13,000	35
		52	SQ5	2-1/2	45507	0	#,HM		1,200/12,000	1,700/14,000	45
Savana 2500	04-16	50	SQ3	2	37136		HM		500/5,000	600/6,000	30
Savana 2500	04-17	34	SQ2	1-1/4	36206	0	HM	36053	300/3,500		15
		22	SQ3	2	75189	0	HM		500/5,000	750/7,500	15
		33	SQ4	2	41521	0	HM		600/6,000	1,000/10,000	15
		42	SQ5	2	41946		@,HM		1,500/10,000	1,300/13,000	35
		52	SQ5	2-1/2	45507	0	#,HM		1,200/12,000	1,700/14,000	45
Savana 3500	96-99	34	SQ2	1-1/4	36206	0	HM	36053	300/3,500		15
		50	SQ3	2	37136		HM		500/5,000	600/6,000	30
		22	SQ3	2	75189	0	HM		500/5,000	750/7,500	15
		33	SQ4	2	41521	0	HM		600/6,000	1,000/10,000	15
		42	SQ5	2	41946		@,HM		1,500/10,000	1,300/13,000	35
Savana 3500	00-02	52	SQ5	2-1/2	45507	0	#,HM		1,200/12,000	1,700/14,000	45
		34	SQ2	1-1/4	36206	0	HM	36053	300/3,500		15
		50	SQ3	2	37136		HM		500/5,000	600/6,000	30
		22	SQ3	2	75189	0	HM		500/5,000	750/7,500	15
		33	SQ4	2	41521	0	HM		600/6,000	1,000/10,000	15
		42	SQ5	2	41946		@,HM		1,500/10,000	1,300/13,000	35
52	SQ5	2-1/2	45507	0	#,HM	1,200/12,000	1,700/14,000		45		

Titan hitches require use of a 2-1/2" shank Titan ball mount.
 @ Ultra Frame ball mount must be used to achieve maximum weight carrying rating.

HM Hitch cross tube is visible beneath bumper.

RECEIVER HITCH APPLICATION GUIDE

T-ONE						TOW HARNESS						4-FLAT WIRING				REQ. 4 FLAT WIRING		7-WAY HARDWIRE	BRAKE CONTROL HARNESS	IN
PC	T-ONE	FN	IN	AMP	CP	PC	TOW HARN	FN	IN	AMP	CP	TYPE	ELEC	POS	CHOICE 1	CHOICE 2	6-WAY ADAPTER			
GMC (Continued)																				
E8	118377	HG	10	2.1.5		E1	118240	RD	5	7.5		4-Flat	B	SUV3,4	119130	119178	20320	20321	20224	
E5	118392		20	7.5		E1	118240	RD	5	7.5		4-Flat	A	SUV3,4	119180	20252	20320	20321	20224	
E5	118392		20	7.5									A	SUV3,4	119180	20252	20320	20321	20224	
E8	118335	HG	10	2.1.5		E1	118240	RD	5	7.5		4-Flat	B	SUV3,4	119130	119178	20320	20321	20224	
E8	118377	HG	10	2.1.5		E1	118240	RD	5	7.5		4-Flat	B	SUV3,4	119130	119178	20320	20321	20224	
E5	118392		20	7.5		E1	118240	RD	5	7.5		4-Flat	A	SUV3,4	119180	20252	20320	20321	20224	
E5	118392		20	7.5									A	SUV3,4	119180	20252	20320	20321	20224	
E5	118392		20	7.5									A	SUV3,4	119180	20252	20320	20321	20224	
E8	118335	HG	10	2.1.5		E1	118240	RD	5	7.5		4-Flat	B	SUV3,4	119130	119178	20320	20321	20224	
E8	118377	HG	10	2.1.5		E1	118240	RD	5	7.5		4-Flat	B	SUV3,4	119130	119178	20320	20321	20224	

- A** 2 wire system.
- B** 3 wire system. Converter required.

- HG** T-One incorporates taillight converter.
- RD** For vehicles equipped with factory tow package may require additional components or may be used as a replacement harness.

- SQ2** Square Tube Class II
- SQ3** Square Tube Class III
- SQ4** Square Tube Class IV
- SQ5** Square Tube Class V

RECEIVER HITCH APPLICATION GUIDE

MODEL / STYLE	YEAR	TRAILER HITCHES									
		PC	REC TYPE	REC SIZE	PART #	NO DRILL	FOOTNOTES	OPTIONAL DRAWBAR	WC (LBS.)	WD (LBS.)	IN
GMC (Continued)											
Savana 3500	03-03	34	SQ2	1-1/4	36206	0	HM	36053	300/3,500		15
		50	SQ3	2	37136	0	HM		500/5,000	600/6,000	30
		22	SQ3	2	75189	0	HM		500/5,000	750/7,500	15
		33	SQ4	2	41521	0	HM		600/6,000	1,000/10,000	15
		42	SQ5	2	41946	0	@,HM		1,500/10,000	1,300/13,000	35
		52	SQ5	2-1/2	45507	0	#,HM		1,200/12,000	1,700/14,000	45
Savana 3500	04-16	50	SQ3	2	37136		HM		500/5,000	600/6,000	30
Savana 3500	04-17	34	SQ2	1-1/4	36206	0	HM	36053	300/3,500		15
		22	SQ3	2	75189	0	HM		500/5,000	750/7,500	15
		33	SQ4	2	41521	0	HM		600/6,000	1,000/10,000	15
		42	SQ5	2	41946	0	@,HM		1,500/10,000	1,300/13,000	35
		52	SQ5	2-1/2	45507	0	#,HM		1,200/12,000	1,700/14,000	45
		Sierra Denali HD 6.6 ft. Bed, w/Factory 7-Way	11-13								
Sierra 1500	99-02	49	RT3	2	37133	0			500/5,000	750/7,500	25
		39	SQ4	2	41534	0			600/6,000	1,200/12,000	20
		54	RT4	2	37130	0			700/7,000	1,200/12,000	25
		30	RT4	2	75362	0	JL		900/6,000	900/8,000	15
		22	RT4	2	75521	0	JL,SZ		900/6,000	1,050/10,500	15
		50	SQ5	2	41932	0	@,HM,JL		1,200/12,000	1,400/14,000	20
Sierra 1500 w/Factory 7-Way	99-12										
Sierra 1500 (Classic)	03-07	49	RT3	2	37133	0			500/5,000	750/7,500	25
		39	SQ4	2	41534	0			600/6,000	1,200/12,000	20
		54	RT4	2	37130	0			700/7,000	1,200/12,000	25
		30	RT4	2	75362	0	JL		900/6,000	900/8,000	15
		22	RT4	2	75521	0	JL,SZ		900/6,000	1,050/10,500	15
		50	SQ5	2	41932	0	@,HM,JL		1,200/12,000	1,400/14,000	20
Sierra 1500	07-13	30	RT4	2	75362	0	JL		900/6,000	900/8,000	15
		22	RT4	2	75521	0	JL,SZ		900/6,000	1,050/10,500	15
Sierra 1500	14-17	33	RT4	2	75866	0	HM,JL		900/6,000	1,200/12,000	20
		31	SQ4	2	76016	0	GP,JL		900/6,000	1,000/10,000	25
Sierra 1500 HD	01-02	49	RT3	2	37133	0			500/5,000	750/7,500	25
		39	SQ4	2	41534	0			600/6,000	1,200/12,000	20
		54	RT4	2	37130	0			700/7,000	1,200/12,000	25
		30	RT4	2	75362	0	JL		900/6,000	900/8,000	15
		22	RT4	2	75521	0	JL,SZ		900/6,000	1,050/10,500	15
		50	SQ5	2	41932	0	@,HM,JL		1,200/12,000	1,400/14,000	20
Sierra 1500 HD w/Factory 7-Way	01-07										
Sierra 1500 HD	03-03	49	RT3	2	37133	0			500/5,000	750/7,500	25
		39	SQ4	2	41534	0			600/6,000	1,200/12,000	20
		54	RT4	2	37130	0			700/7,000	1,200/12,000	25
		30	RT4	2	75362	0	JL		900/6,000	900/8,000	15
		22	RT4	2	75521	0	JL,SZ		900/6,000	1,050/10,500	15
		50	SQ5	2	41932	0	@,HM,JL		1,200/12,000	1,400/14,000	20

Titan hitches require use of a 2-1/2" shank Titan ball mount.
 @ Ultra Frame ball mount must be used to achieve maximum weight carrying rating.
 GP Hitch cross-tube concealed behind bumper.

HM Hitch cross-tube is visible beneath bumper.
 JL Installation requires OEM bumper and brackets.
 SZ Hitches produced before 03/10/11 are rated at 600/6000 WC.

RECEIVER HITCH APPLICATION GUIDE

T-ONE						TOW HARNESS						4-FLAT WIRING				REQ. 4 FLAT WIRING		7-WAY HARDWIRE	BRAKE CONTROL HARNESS	IN	
PC	T-ONE	FN	IN	AMP	CP	PC	TOW HARN	FN	IN	AMP	CP	TYPE	ELEC	POS	CHOICE 1	CHOICE 2	6-WAY ADAPTER				7-WAY ADAPTER
GMC (Continued)																					
E5	118392		20	7.5		E1	118240	RD	5	7.5		4-Flat	A	SUV3,4	119180	20252	20320	20321	20224		
E5	118392		20	7.5									A	SUV3,4	119180	20252	20320	20321	20224		
E5	118392		20	7.5									A	SUV3,4	119180	20252	20320	20321	20224		
							20119 20047 118015	RD RD RD	10 5 10			Both 7-Way 7-Way	A	PU3	119180	20252					
						E8	118384	BN,RD	5	7.5		4-Flat	A	PU3	119180	20252	20320	20321	20224	3025-P	5
							20119 20047 118015	RD RD RD	10 5 10			Both 7-Way 7-Way	H	PU3	119180	20252					
						E8	118384	BN,RD	5	7.5		4-Flat	A	PU3	119180	20252	20320	20321	20224	3015-P	5
E8	118384	BN	5	7.5									A	PU3	119180	20252	20320	20321	20224		
E8	118384		5	7.5									A	PU3	119180	20252	20320	20321	20224	3016-P	5
						E8	118384	BN,RD	5	7.5		4-Flat	A	PU3	119180	20252	20320	20321	20224	3025-P	5
							20119 118015 20047	RD RD RD	10 10 5			Both 7-Way 7-Way	H	PU3	119180	20252					
						E8	118384	BN,RD	5	7.5		4-Flat	A	PU3	119180	20252	20320	20321	20224	3015-P	5

A 2 wire system.
BN Exterior mounted plug on some or all models. May require an aftermarket electrical mounting box or bracket. (Sold separately)

H 3 wire system with OEM standard 2 wire harness.
RD For vehicles equipped with factory tow package may require additional components or may be used as a replacement harness.

RT3 Round Tube Class III 2"
RT4 Round Tube Class IV 2"
SQ2 Square Tube Class II
SQ3 Square Tube Class III
SQ4 Square Tube Class IV
SQ5 Square Tube Class V

RECEIVER HITCH APPLICATION GUIDE

MODEL / STYLE	YEAR	TRAILER HITCHES									
		PC	REC TYPE	REC SIZE	PART #	NO DRILL	FOOTNOTES	OPTIONAL DRAWBAR	WC (LBS.)	WD (LBS.)	IN
GMC (Continued)											
Sierra 1500 HD (Classic)	05-07	49	RT3	2	37133	0			500/5,000	750/7,500	25
		39	SQ4	2	41534	0			600/6,000	1,200/12,000	20
		54	RT4	2	37130	0			700/7,000	1,200/12,000	25
		30	RT4	2	75362	0	JL		900/6,000	900/8,000	15
		22	RT4	2	75521	0	JL,SZ		900/6,000	1,050/10,500	15
		50	SQ5	2	41932	0	@,HM,JL		1,200/12,000	1,400/14,000	20
Sierra 2500	99-02	49	RT3	2	37133	0			500/5,000	750/7,500	25
		39	SQ4	2	41534	0			600/6,000	1,200/12,000	20
		54	RT4	2	37130	0			700/7,000	1,200/12,000	25
		30	RT4	2	75362	0	JL		900/6,000	900/8,000	15
		22	RT4	2	75521	0	JL,SZ		900/6,000	1,050/10,500	15
		50	SQ5	2	41932	0	@,HM,JL		1,200/12,000	1,400/14,000	20
59	SQ5	2-1/2	45512	0	#		1,200/12,000	1,700/14,000	20		
Sierra 2500 w/Factory 7-Way	99-04										
Sierra 2500	03-04	49	RT3	2	37133	0			500/5,000	750/7,500	25
		39	SQ4	2	41534	0			600/6,000	1,200/12,000	20
		54	RT4	2	37130	0			700/7,000	1,200/12,000	25
		30	RT4	2	75362	0	JL		900/6,000	900/8,000	15
		22	RT4	2	75521	0	JL,SZ		900/6,000	1,050/10,500	15
		50	SQ5	2	41932	0	@,HM,JL		1,200/12,000	1,400/14,000	20
59	SQ5	2-1/2	45512	0	#		1,200/12,000	1,700/14,000	20		
Sierra 2500 HD	01-02	46	SQ4	2	41544	0	HM,SA		600/6,000	1,200/12,000	20
		34	RT4	2	75550	0	CS,FS,JL,LT		600/6,000	1,100/11,000	20
		35	SQ5	2	41944	0	@,CS,FS,HM,LT		1,950/13,000	1,600/16,000	25
		58	SQ5	2-1/2	45517	0	#,CS,FS,LT		1,300/13,000	1,700/17,000	25
Sierra 2500 HD 8 ft. Bed	01-02	60	SQ5	2-1/2	45519	0	#,CS,FS,LT		2,000/18,000	2,500/18,000	25
Sierra 2500 HD w/Factory 7-Way	01-16										
Sierra 2500 HD (Classic)	03-07	46	SQ4	2	41544	0	HM,SA		600/6,000	1,200/12,000	20
		34	RT4	2	75550	0	CS,FS,JL,LT		600/6,000	1,100/11,000	20
		35	SQ5	2	41944	0	@,CS,FS,HM,LT		1,950/13,000	1,600/16,000	25
		58	SQ5	2-1/2	45517	0	#,CS,FS,LT		1,300/13,000	1,700/17,000	25
Sierra 2500 HD 8 ft. Bed	03-06	60	SQ5	2-1/2	45519	0	#,CS,FS,LT		2,000/18,000	2,500/18,000	25
Sierra 2500 HD	07-10	34	RT4	2	75550	0	CS,FS,JL,LT		600/6,000	1,100/11,000	20
		35	SQ5	2	41944	0	@,CS,FS,HM,LT		1,950/13,000	1,600/16,000	25
		58	SQ5	2-1/2	45517	0	#,CS,FS,LT		1,300/13,000	1,700/17,000	25
Sierra 2500 HD 8 ft. Bed	07-10	60	SQ5	2-1/2	45519	0	#,CS,FS,LT		2,000/18,000	2,500/18,000	25
Sierra 2500 HD 8 ft. Bed (Classic)	07-07	60	SQ5	2-1/2	45519	0	#,CS,FS,LT		2,000/18,000	2,500/18,000	25
Sierra 2500 HD	11-14	43	SQ4	2	75707	0	CS,FS,GP,JL,LT		800/8,000	1,200/12,000	20
		50	SQ5	2	41942	0	@,CS,FS,GP,JL,KH,LT		1,500/15,000	1,600/16,000	20
		67	SQ5	2-1/2	45510	0	#,CS,FS,HM,JL,KH,LT		2,000/18,000	2,500/18,000	60
Sierra 2500 HD	15-16	42	SQ4	2	75906	0	HM,JL		800/8,000	1,200/12,000	30
		48	SQ5	2	41950	0	@,CS,FS,GP,JL,KH,LT		1,700/15,000	1,700/17,000	60
		57	SQ5	2-1/2	45511	0	#,HM		2,700/20,000	2,700/20,000	60
Sierra 3500	01-02	46	SQ4	2	41544	0	HM,SA		600/6,000	1,200/12,000	20
		34	RT4	2	75550	0	CS,FS,JL,LT		600/6,000	1,100/11,000	20
		35	SQ5	2	41944	0	@,CS,FS,HM,LT		1,950/13,000	1,600/16,000	25
		58	SQ5	2-1/2	45517	0	#,CS,FS,LT		1,300/13,000	1,700/17,000	25
		60	SQ5	2-1/2	45519	0	#,CS,FS,LT		2,000/18,000	2,500/18,000	25

Titan hitches require use of a 2-1/2" shank Titan ball mount.
 @ Ultra Frame ball mount must be used to achieve maximum weight carrying rating.
 CS Will fit with full-size spare tire stowed under vehicle.
 FS Includes 2 & 4 WD models with heavy duty suspension.
 GP Hitch crosstube concealed behind bumper.
 HM Hitch crosstube is visible beneath bumper.

JL Installation requires OEM bumper and brackets.
 KH Minor heat shield modification may be required.
 LT Requires removal of factory hitch if equipped.
 SA Requires drilling on 6 ft. bed models.
 SZ Hitches produced before 03/10/11 are rated at 600/6000 WC.

RECEIVER HITCH APPLICATION GUIDE

T-ONE						TOW HARNESS						4-FLAT WIRING				REQ. 4 FLAT WIRING		BRAKE CONTROL HARNESS	IN		
PC	T-ONE	FN	IN	AMP	CP	PC	TOW HARN	FN	IN	AMP	CP	TYPE	ELEC	POS	CHOICE 1	CHOICE 2	6-WAY ADAPTER			7-WAY ADAPTER	7-WAY HARDWIRE
GMC (Continued)																					
						E8	118384	BN,RD	5	7.5		4-Flat	A	PU3	119180	20252	20320	20321	20224	3015-P	5
						E8	118384	BN,RD	5	7.5		4-Flat	A	PU3	119180	20252	20320	20321	20224	3025-P	5
							20047 118015 20119	RD RD RD	5 10 10			7-Way 7-Way Both	H	PU3	119180	20252					
						E8	118384	BN,RD	5	7.5		4-Flat	A	PU3	119180	20252	20320	20321	20224	3015-P	5
						E8	118384	BN,RD	5	7.5		4-Flat	A	PU3	119180	20252	20320	20321	20224	3025-P	5
						E8	118384	BN,RD	5	7.5		4-Flat	A	PU3	119180	20252	20320	20321	20224	3025-P	5
							118015 20047 20119	RD RD RD	10 5 10			7-Way 7-Way Both	H	PU3	119180	20252					
						E8	118384	BN,RD	5	7.5		4-Flat	A	PU3	119180	20252	20320	20321	20224	3015-P	5
						E8	118384	BN,RD	5	7.5		4-Flat	A	PU3	119180	20252	20320	20321	20224	3015-P	5
E8	118384	BN	5	7.5									A	PU3	119180	20252	20320	20321	20224		
E8	118384	BN	5	7.5									A	PU3	119180	20252	20320	20321	20224		
E8	118384	BN	5	7.5		E8	118384	BN,RD	5	7.5		4-Flat	A	PU3	119180	20252	20320	20321	20224	3015-P	5
E8	118384	BN	5	7.5									A	PU3	119180	20252	20320	20321	20224		
													A	PU3	119180	20252	20320	20321	20224	3016-P	5
						E8	118384	BN,RD	5	7.5		4-Flat	A	PU3	119180	20252	20320	20321	20224	3025-P	5

A 2 wire system.
BN Exterior mounted plug on some or all models. May require an aftermarket electrical mounting box or bracket. (Sold separately)

H 3 wire system with OEM standard 2 wire harness.
RD For vehicles equipped with factory tow package may require additional components or may be used as a replacement harness.

RT3 Round Tube Class III 2"
RT4 Round Tube Class IV 2"
SQ4 Square Tube Class IV
SQ5 Square Tube Class V

RECEIVER HITCH APPLICATION GUIDE

MODEL / STYLE	YEAR	TRAILER HITCHES									
		PC	REC TYPE	REC SIZE	PART #	NO DRILL	FOOTNOTES	OPTIONAL DRAWBAR	WC (LBS.)	WD (LBS.)	IN
GMC (Continued)											
Sierra 3500 Cab & Chassis, w/34" Wide Frames (Classic)	01-07	29	SQ5	2	41936		@		1,200/12,000		30
		50	SQ5	2	41938		@,CC		1,200/12,000	1,500/15,000	40
		50	SQ5	2	41947		@		1,600/15,000	1,600/16,000	35
Sierra 3500 w/Factory 7-Way	01-07										
Sierra 3500 (Classic)	03-07	34	RT4	2	75550	0	CS,FS,JL,LT		600/6,000	1,100/11,000	20
Sierra 3500 (Classic)	03-07	46	SQ4	2	41544	0	HM,SA		600/6,000	1,200/12,000	20
		35	SQ5	2	41944	0	@,CS,FS,HM,LT		1,950/13,000	1,600/16,000	25
		58	SQ5	2-1/2	45517	0	#,CS,FS,LT		1,300/13,000	1,700/17,000	25
		60	SQ5	2-1/2	45519	0	#,CS,FS,LT		2,000/18,000	2,500/18,000	25
Sierra 3500 HD	07-10	34	RT4	2	75550	0	CS,FS,JL,LT		600/6,000	1,100/11,000	20
		35	SQ5	2	41944	0	@,CS,FS,HM,LT		1,950/13,000	1,600/16,000	25
		58	SQ5	2-1/2	45517	0	#,CS,FS,LT		1,300/13,000	1,700/17,000	25
		60	SQ5	2-1/2	45519	0	#,CS,FS,LT		2,000/18,000	2,500/18,000	25
Sierra 3500 HD	07-16										
Sierra 3500 HD Cab & Chassis, w/34" Wide Frames	07-16	29	SQ5	2	41936		@		1,200/12,000		30
		50	SQ5	2	41938		@,CC		1,200/12,000	1,500/15,000	40
		50	SQ5	2	41947		@		1,600/15,000	1,600/16,000	35
Sierra 3500 HD	11-14	43	SQ4	2	75707	0	CS,FS,GP,JL,LT		800/8,000	1,200/12,000	20
		50	SQ5	2	41942	0	@,CS,FS,GP,JL,KH,LT		1,500/15,000	1,600/16,000	20
		67	SQ5	2-1/2	45510		#,CS,FS,HM,JL,KH,LT		2,000/18,000	2,500/18,000	60
Sierra 3500 HD	15-16	42	SQ4	2	75906	0	HM,JL		800/8,000	1,200/12,000	30
		48	SQ5	2	41950	0	@,CS,FS,GP,JL,KH,LT		1,700/15,000	1,700/17,000	60
		57	SQ5	2-1/2	45511		#,HM		2,700/20,000	2,700/20,000	60
Sonoma w/Sportside Bed & Non-Towing Bumper	96-97	30	SQ3	2	75085	0			350/3,500	750/6,000	40
Sonoma	98-04	34	SQ2	1-1/4	36248	0	GU,RH,GP	36071	300/3,500		35
		30	SQ3	2	75085	0			350/3,500	750/6,000	40
		50	SQ3	2	37136		AF,CN,GU,ST		500/5,000	600/6,000	40
Suburban C1500	92-99	50	SQ3	2	37136				500/5,000	600/6,000	30
		37	SQ3	2	75037		HM		500/5,000	750/7,500	30
		41	SQ4	2	41511		HM		600/6,000	1,000/10,000	30
Suburban C2500	92-99	50	SQ3	2	37136				500/5,000	600/6,000	30
		37	SQ3	2	75037		HM		500/5,000	750/7,500	30
		41	SQ4	2	41511		HM		600/6,000	1,000/10,000	30
Suburban K1500	92-99	50	SQ3	2	37136				500/5,000	600/6,000	30
		37	SQ3	2	75037		HM		500/5,000	750/7,500	30
		41	SQ4	2	41511		HM		600/6,000	1,000/10,000	30
Suburban K2500	92-99	50	SQ3	2	37136				500/5,000	600/6,000	30
		37	SQ3	2	75037		HM		500/5,000	750/7,500	30
		41	SQ4	2	41511		HM		600/6,000	1,000/10,000	30
Terrain	10-17	18	SQ2	1-1/4	36408	0	HM	36051	300/3,500		25
		15	RT3	2	76028	0	HM		675/4,500	675/4,500	30
Yukon	92-00	50	SQ3	2	37136				500/5,000	600/6,000	30
		37	SQ3	2	75037		HM		500/5,000	750/7,500	30
		41	SQ4	2	41511		HM		600/6,000	1,000/10,000	30
Yukon w/Amber Turn Signals	00-02	50	SQ3	2	37136				500/5,000	600/6,000	30
		29	RT4	2	75725	0	CN,HM		900/6,000	1,000/10,000	15
Yukon w/Factory 7-Way	00-11										

- # Titan hitches require use of a 2-1/2" shank Titan ball mount.
- @ Ultra Frame ball mount must be used to achieve maximum weight carrying rating.
- AF Hitch is ONLY rated for Weight Carrying at 3500 lbs. GTW / 350 lbs. TW and DO NOT use Weight Distribution Spring Bars for this Specific Vehicle. Except for long bed pickups.
- CC Requires minimum of 19" from end of frame rail to spring shackle bracket.
- CN Requires OEM factory bumper for hitch installation.
- CS Will fit with full-size spare tire stowed under vehicle.
- FS Includes 2 & 4 WD models with heavy duty suspension.
- GP Hitch crosstube concealed behind bumper.
- GU Will not fit vehicles with factory or aftermarket lower Fascia/Rollpan or Tube Bumper.
- HM Hitch crosstube is visible beneath bumper.
- JL Installation requires OEM bumper and brackets.
- KH Minor heat shield modification may be required.
- LT Requires removal of factory hitch if equipped.
- RH Optional drawbar #36051 required (Sold separately) except for models with ZR2 & Highrider package.
- SA Requires drilling on 6 ft. bed models.
- ST Will not fit 2WD models with short bed.

RECEIVER HITCH APPLICATION GUIDE

T-ONE						TOW HARNESS						4-FLAT WIRING				REQ. 4 FLAT WIRING		BRAKE CONTROL HARNESS	IN			
PC	T-ONE	FN	IN	AMP	CP	PC	TOW HARN	FN	IN	AMP	CP	TYPE	ELEC	POS	CHOICE 1	CHOICE 2	6-WAY ADAPTER			7-WAY ADAPTER	7-WAY HARDWIRE	
GMC (Continued)																						
													C	PU1,2	119180	119148	20320	20321	20224			
							20047 118015 20119	RD		5 10 10			7-Way 7-Way Both	H	PU3	119180	20252					
						E8	118384	BN,RD		5	7.5		4-Flat	A	PU3	119180	20252	20320	20321	20224	3015-P	5
						E8	118384	BN,RD		5	7.5		4-Flat	A	PU3	119180	20252	20320	20321	20224	3015-P	5
E8	118384	BN		5	7.5								A	PU3	119180	20252	20320	20321	20224			
E8	118384	BN,RD		5	7.5		118015 20047 20119	RD		10 5 10			7-Way 7-Way Both	A	PU3	119180	20252					
													C	PU1,2	20250	119180	20320	20321	20224			
E8	118384	BN		5	7.5								A	PU3	119180	20252	20320	20321	20224			
													A	PU3	119180	20252	20320	20321	20224	3016-P	5	
E3	118312	BN		5	7.5								A	PU3	119180	20252	20320	20321	20224			
E4	118359	BN		5	7.5								A	PU3	119180	20252	20320	20321	20224			
E3	118319	BN		5	7.5								A	SUV6	119180	20252	20320	20321	20224			
E3	118319	BN		5	7.5								A	SUV6	119180	20252	20320	20321	20224			
E3	118319	BN		5	7.5								A	SUV6	119180	20252	20320	20321	20224			
E3	118319	BN		5	7.5								A	SUV6	119180	20252	20320	20321	20224			
E16	118494	CH	45	2.1,5.6	X	E1	118264	RD		15	7.5		4-Flat	N	SUV1,2		119251	20320	20321			
E3	118319	BN		5	7.5								A	SUV6	119180	20252	20320	20321	20224			
E8	118384	BN		5	7.5								A	SUV6	119180	20252	20320	20321	20224	3025-P	5	
							20119 20047 118015	RD		10 5 10			Both 7-Way 7-Way	H	SUV6	119180	20252					

A 2 wire system.
BN Exterior mounted plug on some or all models. May require an aftermarket electrical mounting box or bracket. (Sold separately)
C 2 or 3 wire system determine at installation.
CH T-One is equipped with circuit protected Modulite® module.

H 3 wire system with OEM standard 2 wire harness.
N DO NOT cut or splice vehicle wiring. Only use approved T-One or see auto dealer for trailer tow wiring kit.
RD For vehicles equipped with factory tow package may require additional components or may be used as a replacement harness.

RT3 Round Tube Class III 2"
RT4 Round Tube Class IV 2"
SQ2 Square Tube Class II
SQ3 Square Tube Class III
SQ4 Square Tube Class IV
SQ5 Square Tube Class V

RECEIVER HITCH APPLICATION GUIDE

MODEL / STYLE	YEAR	TRAILER HITCHES									
		PC	REC TYPE	REC SIZE	PART #	NO DRILL	FOOTNOTES	OPTIONAL DRAWBAR	WC (LBS.)	WD (LBS.)	IN
GMC (Continued)											
Yukon w/Amber Turn Signals	03-06	50 29	SQ3 RT4	2 2	37136 75725	0	CN, HM		500/5,000 900/6,000	600/6,000 1,000/10,000	30 15
Yukon	07-11										
Yukon Denali	99-00	50 37 41	SQ3 SQ3 SQ4	2 2 2	37136 75037 41511		HM HM		500/5,000 500/5,000 600/6,000	600/6,000 750/7,500 1,000/10,000	30 30 30
Yukon Denali w/Amber Turn Signals	01-02	50 29	SQ3 RT4	2 2	37136 75725	0	CN, HM		500/5,000 900/6,000	600/6,000 1,000/10,000	30 15
Yukon Denali w/Factory 7-Way	01-11										
Yukon Denali	03-11										
Yukon XL w/Factory 7-Way	00-11										
Yukon XL	07-11										
Yukon XL 1500	00-02	50 29 30	SQ3 RT4 SQ5	2 2 2	37136 75725 41930	0	CN, HM @, CN, HM		500/5,000 900/6,000 1,000/10,000	600/6,000 1,000/10,000 1,200/12,000	30 15 35
Yukon XL 1500	03-06	50 29 30	SQ3 RT4 SQ5	2 2 2	37136 75725 41930	0	CN, HM @, CN, HM		500/5,000 900/6,000 1,000/10,000	600/6,000 1,000/10,000 1,200/12,000	30 15 35
Yukon XL 1500 Denali	01-02	50 29 30	SQ3 RT4 SQ5	2 2 2	37136 75725 41930	0	CN, HM @, CN, HM		500/5,000 900/6,000 1,000/10,000	600/6,000 1,000/10,000 1,200/12,000	30 15 35
Yukon XL 1500 Denali w/Factory 7-Way	01-11										
Yukon XL 1500 Denali	03-11										
Yukon XL 2500	00-02	50 29 30 53	SQ3 RT4 SQ5 SQ5	2 2 2 2-1/2	37136 75725 41930 45515	0	CN, HM @, CN, HM #		500/5,000 900/6,000 1,000/10,000 1,200/12,000	600/6,000 1,000/10,000 1,200/12,000 1,700/14,000	30 15 35 50
Yukon XL 2500	03-06	50 29 30 53	SQ3 RT4 SQ5 SQ5	2 2 2 2-1/2	37136 75725 41930 45515	0	CN, HM @, CN, HM #		500/5,000 900/6,000 1,000/10,000 1,200/12,000	600/6,000 1,000/10,000 1,200/12,000 1,700/14,000	30 15 35 50
HONDA											
Accord	94-97	45	SQ1	1-1/4	24616	0	HM	3593	200/2,000		30
Accord Sedan	98-02	18	SQ1	1-1/4	24791	0	JR, HM	3592	200/2,000		15
Accord Coupe	03-05	31	SQ1	1-1/4	24787	0	HR, JR, HM	3592	200/2,000		25
Accord Sedan	03-05	31	SQ1	1-1/4	24787	0	HR, JR, HM	3592	200/2,000		25
Accord Coupe	06-07	31	SQ1	1-1/4	24787	0	HR, JR, HM	3592	200/2,000		25
Accord Sedan	06-07	31	SQ1	1-1/4	24787	0	HR, JR, HM	3592	200/2,000		25
Accord Coupe	08-12	19	SQ1	1-1/4	24899	0	HM, JR, KH	3593	200/2,000		30
Accord Sedan	08-12	19	SQ1	1-1/4	24899	0	HM, JR, KH	3593	200/2,000		30
Accord Coupe, Except w/LED Taillights	13-15	19	SQ1	1-1/4	24899	0	HM, JR, KH	3593	200/2,000		30
Accord Coupe, w/LED Taillights	13-15	19	SQ1	1-1/4	24899	0	HM, JR, KH, SV	3593	200/2,000		45
Accord Sedan, Except w/LED Taillights	13-15	19	SQ1	1-1/4	24899	0	HM, JR, KH, SV	3593	200/2,000		45
Accord Sedan, w/LED Taillights	13-15	19	SQ1	1-1/4	24899	0	HM, JR, KH, SV	3593	200/2,000		45
Accord Coupe	16-16	19	SQ1	1-1/4	24899	0	HM, JR, KH	3593	200/2,000		45
Accord Sedan	16-17	19	SQ1	1-1/4	24899	0	HM, JR, KH, SV	3593	200/2,000		30
Accord Crosstour	10-11	31	SQ1	1-1/4	24852	0	HM, JR, KH	3590	200/2,000		40

Titan hitches require use of a 2-1/2" shank Titan ball mount.
 @ Ultra Frame ball mount must be used to achieve maximum weight carrying rating.
 CN Requires OEM factory bumper for hitch installation.
 HM Hitch crosstube is visible beneath bumper.

HR Requires drilling of heat shields on V6 models.
 JR Exhaust must be temporarily lowered for installation.
 KH Minor heat shield modification may be required.
 SV Trimming or removal of under body appearance panel may be required.

RECEIVER HITCH APPLICATION GUIDE

H

HONDA

T-ONE						TOW HARNESS						4-FLAT WIRING				REQ. 4 FLAT WIRING		BRAKE CONTROL HARNESS	IN			
PC	T-ONE	FN	IN	AMP	CP	PC	TOW HARN	FN	IN	AMP	CP	TYPE	ELEC	POS	CHOICE 1	CHOICE 2	6-WAY ADAPTER			7-WAY ADAPTER	7-WAY HARDWIRE	
GMC (Continued)																						
E8	118384	BN	5	7.5									A	SUV6	119180	20252	20320	20321	20224	3015-P	5	
						E8	118384	BN,RD	5	7.5		4-Flat	H	SUV6	119180	20252						
E3	118319	BN	5	7.5									A	SUV6	119180	20252	20320	20321	20224			
E8	118384	BN	5	7.5									A	SUV6	119180	20252	20320	20321	20224	3025-P	5	
							20119 20047 118015	RD RD RD	10 5 10			Both 7-Way 7-Way	H	SUV6	119180	20252						
						E8	118384	BN,RD	5	7.5		4-Flat	H	SUV6	119180	20252					3015-P	5
							20119 20047 118015	RD RD RD	10 5 10			Both 7-Way 7-Way	H	SUV6	119180	20252						
						E8	118384	BN,RD	5	7.5		4-Flat	H	SUV6	119180	20252						
E8	118384	BN	5	7.5									A	SUV6	119180	20252	20320	20321	20224	3025-P	5	
E8	118384	BN	5	7.5									A	SUV6	119180	20252	20320	20321	20224	3015-P	5	
E8	118384	BN	5	7.5									A	SUV6	119180	20252	20320	20321	20224	3025-P	5	
							20119 20047 118015	RD RD RD	10 5 10			Both 7-Way 7-Way	H	SUV6	119180	20252						
						E8	118384	BN,RD	5	7.5		4-Flat	H	SUV6	119180	20252						
E8	118384	BN	5	7.5									A	SUV6	119180	20252	20320	20321	20224	3025-P	5	
E8	118384	BN	5	7.5									A	SUV6	119180	20252	20320	20321	20224	3015-P	5	
HONDA																						
E5	118336	HG	5	2.1,5									B,E	PC3	119148	119180						
E5	118336	HG	5	2.1,5									B	PC3	119130	119178						
E11	118441	CG	10	2.1,5	X								B	PC3	119130	119178						
E11	118302	HG	10	2.1,4.2									B	PC3	119130	119178						
E8	118436	HG	10	2.1,4.2									N	PC3		119251						
E11	118302	HG	10	2.1,4.2									B,E	PC3	119148	119180						
E14	118420	CG	15	2.1,5	X								B	PC3,4	119130	119178						
E14	118420	CG	15	2.1,5	X								B,E	PC3,4	119148	119180						
E16	118596	CH	45	2.1,5.6	X								B,E	PC3,4	119148	119180						
E15	118586	CH	45	2.1,5.6	X								B,E	PC3,4	119148	119180						
E16	118596	CH	45	2.1,5.6	X								B,E	PC3,4	119148	119180						
E15	118586	CH	45	2.1,5.6	X								B,E	PC3,4	119148	119180						
E17	118695	CH	45	4.2,7.5	X								B,E	PC3,4	119148	119180						
E16	118684	CH	45	4.2,7.5	X								B,E	PC3,4	119148	119180						
E11	118500	CH	15	2.1,5.6	X								B,E	SUV3	119148	119180	20320	20321				

- A** 2 wire system.
- B** 3 wire system. Converter required.
- BN** Exterior mounted plug on some or all models. May require an aftermarket electrical mounting box or bracket. (Sold separately)
- CG** T-One incorporates circuit protected taillight converter.
- CH** T-One is equipped with circuit protected ModuLite® module.
- E** ModuLite® required.
- H** 3 wire system with OEM standard 2 wire harness.
- HG** T-One incorporates taillight converter.
- N** DO NOT cut or splice vehicle wiring. Only use approved T-One or see auto dealer for trailer tow wiring kit.
- RD** For vehicles equipped with factory tow package may require additional components or may be used as a replacement harness.

- RT4** Round Tube Class IV 2"
- SQ1** Square Tube Class I
- SQ3** Square Tube Class III
- SQ4** Square Tube Class IV
- SQ5** Square Tube Class V

RECEIVER HITCHES

RECEIVER HITCH APPLICATION GUIDE

MODEL / STYLE	YEAR	TRAILER HITCHES									
		PC	REC TYPE	REC SIZE	PART #	NO DRILL	FOOTNOTES	OPTIONAL DRAWBAR	WC (LBS.)	WD (LBS.)	IN
HONDA (Continued)											
Civic	92-98	29	SQ1	1-1/4	24677	0	EP, HM	3593	200/2,000		15
Civic 3 Dr. Hatchback	96-00	11	SQ1	1-1/4	24822	0	X, GP	3590	200/2,000		20
Civic	99-00	29	SQ1	1-1/4	24677	0	HM	3593	200/2,000		15
Civic	01-05	31	SQ1	1-1/4	24706		HM	3593	200/2,000		15
Civic Si	02-05	20	SQ1	1-1/4	24719		TA, GP	3593	200/2,000		30
Civic 2 Dr. Coupe, Except Si	06-15	27	SQ1	1-1/4	24763	0	HM, JR	3593	200/2,000		30
Civic 4 Dr. Sedan, Except Hybrid & Si	06-15	27	SQ1	1-1/4	24763	0	HM, JR	3593	200/2,000		30
Civic Hybrid	06-11	27	SQ1	1-1/4	24763	0	HM, JR	3593	200/2,000		30
Civic Si, 2 Dr. Coupe	06-11	27	SQ1	1-1/4	24763	0	HM, JR	3593	200/2,000		30
Civic Si, 4 Dr. Sedan	06-11	27	SQ1	1-1/4	24763	0	HM, JR	3593	200/2,000		30
Civic Hybrid	12-15	27	SQ1	1-1/4	24763		HM, JR, KH, SV	3593	200/2,000		35
Civic Coupe	16-16	24	SQ1		24946		EP, GP, AA, DU	3593	200/2,000		65
Civic Sedan	16-16	24	SQ1		24946		EP, GP, AA, DU	3593	200/2,000		65
		24	SQ1	1-1/4	24937	0	EP, GP, AA, DU	3593	200/2,000		65
Crosstour	12-12	31	SQ1	1-1/4	24852	0	HM, JR, KH	3590	200/2,000		40
Crosstour	13-13	31	SQ1	1-1/4	24852	0	HM, JR, KH	3590	200/2,000		40
Crosstour	14-15	31	SQ1	1-1/4	24852	0	HM, JR, KH	3590	200/2,000		40
CR-V	97-01	18	SQ1	1-1/4	24790	0	RC, GP	3591	200/2,000		20
CR-V	02-06	27	SQ1	1-1/4	24772	0	BY, JR, HM	3593	200/2,000		20
		33	SQ3	2	75690	0	BY, HM, JR		350/3,500		30
CR-V	07-11	12	SQ1	1-1/4	24792	0	JR, HM	3592	200/2,000		20
		34	RT3	2	75547	0	HM, JR, TJ		675/4,500		25
CR-V	12-16	16	RT2	1-1/4	36520	0	HM, JR, SV	36051	300/3,500		40
		16	RT3	2	75742	0	HM, JR, SV		675/4,500		40
CR-Z	11-12										
Element	03-04	19	SQ1	1-1/4	24720		GP	3592	200/2,000		25
		40	RT3	2	75659	0			350/3,500		30
Element Except SC	05-06	19	SQ1	1-1/4	24720		GP	3592	200/2,000		25
		40	RT3	2	75659	0			350/3,500		30
Element SC	05-06	40	RT3	2	75659	0	EP		350/3,500		35
Element Except SC	07-08	19	SQ1	1-1/4	24720		GP	3592	200/2,000		25
		40	RT3	2	75659	0			350/3,500		30
Element SC	07-10	40	RT3	2	75659	0	EP		350/3,500		35
Element Except SC	09-11	19	SQ1	1-1/4	24720		GP	3592	200/2,000		25
		40	RT3	2	75659	0			350/3,500		30
Fit	07-08	18	SQ1	1-1/4	24776	0	HM	3593	200/2,000		25
Fit	09-13	21	SQ1	1-1/4	24826	0	HM	3593	200/2,000		25
Fit	15-16	16	RT1	1-1/4	24920	0	HM, JR	3593	200/2,000		25
HR-V	16-17	18	RT1	1-1/4	24932	0	GP, JR, SV	3593	200/2,000		35
Odyssey	95-98	35	SQ2	1-1/4	36204		HM, JR	36051	300/3,500		30
Odyssey	99-04	32	SQ2	1-1/4	36417	0	HM, JR	36071	300/3,500		20
		21	RT3	2	75270	0	HM, JR		675/4,500	675/5,000	15
Odyssey	05-10	32	SQ2	1-1/4	36417	0	HM, JR	36071	300/3,500		20
		21	RT3	2	75270	0	HM, JR		675/4,500	675/5,000	15
Odyssey	11-16	32	SQ2	1-1/4	36417	0	HM, JR	36071	300/3,500		20
		32	SQ3	2	76025	0	GP, X, DU		525/3,500		80
		21	RT3	2	75270	0	HM, JR		675/4,500	675/5,000	15
Passport	94-97	39	SQ3	2	75049	0			500/5,000		40
Passport w/Door Mounted Spare	98-01	29	SQ2	1-1/4	36247	0	GP	36053	300/3,500		15
		34	SQ3	2	75092	0			350/3,500	500/5,000	15
Passport w/Under Vehicle Spare	98-02	30	RT3	2	75093	0			350/3,500	500/5,000	15
Pilot	03-08	31	SQ3	2	75599	0	CS, GP, JR		350/3,500	500/5,000	30
Pilot	09-11										

AA Requires temporary removal of bumper during installation.
BY Minor repositioning of muffler required.
CS Will fit with full-size spare tire stowed under vehicle.
DU Fascia removal required.
EP Fascia trimming may be required.
GP Hitch crosstube concealed behind bumper.
HM Hitch crosstube is visible beneath bumper.

JR Exhaust must be temporarily lowered for installation.
KH Minor heat shield modification may be required.
RC Will not fit with rear sport bars.
SV Trimming or removal of under body appearance panel may be required.
TA Trunk access required for hitch installation.
TJ Hitches produced before 07/13/11 are rated at 350/3500 WC.
X Minor fascia trimming required.

RECEIVER HITCH APPLICATION GUIDE

T-ONE						TOW HARNESS						4-FLAT WIRING				REQ. 4 FLAT WIRING		BRAKE CONTROL HARNESS	IN		
PC	T-ONE	FN	IN	AMP	CP	PC	TOW HARN	FN	IN	AMP	CP	TYPE	ELEC	POS	CHOICE 1	CHOICE 2	6-WAY ADAPTER			7-WAY ADAPTER	7-WAY HARDWIRE
HONDA (Continued)																					
													B,E	PC3,4	119148	119180					
													B	PC3,4	119130	119178					
													B,E	PC3,4	119148	119180					
													B,E	PC3,4	119148	119180					
													B	PC3,4	119130	119178					
E12	118437	CG	10	2.1,5	X								B	PC3,4	119130	119178					
E14	118420	CG	15	2.1,5	X								B	PC3,4	119130	119178					
													B	PC3,4	119130	119178					
													B	PC3,4	119130	119178					
													B	PC3,4	119130	119178					
													B,E	PC3,4	119148	119180					
E19	118724	CH	45	5/7.5	X								B,E	PC3,4	119148	119180					
													B,E	PC3,4	119148	119180					
E11	118500	CH	15	2.1,5,6	X								B,E	SUV3	119148	119180	20320	20321			
													B,E	SUV3	119148	119180	20320	20321			
E11	118642	CH	15	2.1,5,6	X								B,E	SUV3	119148	119180	20320	20321			
E5	118336	HG	5	2.1,5									B	SUV3	119130	119178					
E5	118336	HG	5	2.1,5									B	SUV3	119130	119178	20320	20321	20224		
E8	118427	CG	45	2.1,5	X								B	SUV3	119130	119178	20320	20321	20224		
E17	118561	CH	45	2.1,5	X								B,E	SUV1,2	119148	119180	20320	20321	20224		
E17	118533	CH	45	2.1,5,6	X								B,E	PC3,4	119148	119180					
E5	118336	HG	5	2.1,5									B	SUV2	119130	119178	20320	20321	20224		
													B,E	SUV3,4	119148	119180	20320	20321	20224		
													B,E	SUV3,4	119148	119180	20320	20321	20224		
E14	118465	CH	45	2.1,5,6	X								B,E	SUV3,4	119148	119180	20320	20321	20224		
													B,E	SUV3,4	119148	119180	20320	20321	20224		
E14	118465	CH	45	2.1,5,6	X								B,E	SUV3,4	119148	119180	20320	20321	20224		
E14	118465	CH	45	2.1,5,6	X								B,E	SUV3,4	119148	119180	20320	20321	20224		
E14	118420	CG	15	2.1,5	X								B	PC3,4	119130	119178					
E14	118420	CG	15	2.1,5	X								B	PC3,4	119130	119178					
													B	PC3,4	119130	119178					
													B,E	SUV3,4	119148	119180					
E5	118336	HG	5	2.1,5									B	SUV3	119130	119178					
E5	118336	HG	5	2.1,5									B	SUV3	119130	119178	20320	20321	20224		
E12	118438	CH	20	2.1,4,2	X								B	SUV3,4	119130	119178	20320	20321	20224		
E17	118521	CH	30	4.2,7.5	X								B,E	SUV1,2	119148	119180	20320	20321	20224		
E5	118331	BN,HG	5	2.1,5									B	SUV1,2	119130	119178	20320	20321	20224		
E17	118360	BN,HG	15	2.1,5									B	SUV1,2	119130	119178	20320	20321	20224		
E17	118360	BN,HG	15	2.1,5									B	SUV1,2	119130	119178	20320	20321	20224		
E5	118336	HG	5	2.1,5									B	SUV3	119130	119178	20320	20321	20224		
E15	118491	BN,CH	20	4.2,7.5	X	E22	118253	BN,CH	20	4.2,7.5	X	7-Way	B	SUV3,6	119130	119178				3070-P	5

B 3 wire system. Converter required.
BN Exterior mounted plug on some or all models. May require an aftermarket electrical mounting box or bracket. (Sold separately)
CG T-One incorporates circuit protected taillight converter.

CH T-One is equipped with circuit protected Modulite® module.
E Modulite® required.
HG T-One incorporates taillight converter.

RT1 Round Tube Class I 1-1/4"
RT2 Round Tube Class II 1-1/4"
RT3 Round Tube Class III 2"
SQ1 Square Tube Class I
SQ2 Square Tube Class II
SQ3 Square Tube Class III

RECEIVER HITCH APPLICATION GUIDE

MODEL / STYLE	YEAR	TRAILER HITCHES									
		PC	REC TYPE	REC SIZE	PART #	NO DRILL	FOOTNOTES	OPTIONAL DRAWBAR	WC (LBS.)	WD (LBS.)	IN
HONDA (Continued)											
Pilot	12-13										
Pilot	16-16	37	SQ4	2	75225	0	TA,GP		900/6,000	900/8,000	20
Ridgeline	06-14	40	RT3	2	75280	0	HM,JR,TK		750/5,000	750/7,500	20
HUMMER											
H2 w/Factory 7-Way	03-09										
H3	06-10	43	SQ3	2	75382	0			500/5,000	500/5,000	25
H3 w/Factory 7-Way	06-10										
H3T w/Factory 7-Way	09-10										
HYUNDAI											
Accent	00-05	36	SQ1	1-1/4	24736	0	GP	3593	200/2,000		20
Accent 4 Dr. Sedan	06-11	32	SQ1	1-1/4	24760	0	GP	3590	200/2,000		20
Accent 3 Dr. Hatchback	07-11	28	SQ1	1-1/4	24795	0	JR,GP	3594	200/2,000		25
Accent 4 Dr. Sedan	12-16	30	SQ1	1-1/4	24884	0	HM	3592	200/2,000		15
Accent 5 Dr. Hatchback	12-16	30	SQ1	1-1/4	24884	0	HM	3592	200/2,000		15
Azera	06-11	32	SQ1	1-1/4	24771	0	JR,HM	3593	200/2,000		20
Azera	12-16	28	RT2	1-1/4	36544		HM,JR	36061	300/3,500		20
Elantra	96-00	27	SQ1	1-1/4	24646		TA,GP	3593	200/2,000		30
Elantra	01-06	33	SQ1	1-1/4	24703	0	HM	3593	200/2,000		15
Elantra 4 Dr. Sedan	07-10	28	SQ1	1-1/4	24795	0	JR,X,GP	3594	200/2,000		25
Elantra Touring, 5 Dr.	09-12	14	SQ1	1-1/4	24844	0	GP,JR	3594	200/2,000		25
Elantra 4 Dr. Sedan	11-12	17	SQ1	1-1/4	24902		HM	3594	200/2,000		25
Elantra 2 Dr. Coupe	13-15	17	SQ1	1-1/4	24902		HM,SV	3594	200/2,000		25
Elantra 4 Dr. Sedan	13-16	17	SQ1	1-1/4	24902		HM,SV	3594	200/2,000		25
Elantra	17-17	15	SQ1	1-1/4	24939		EP,JR,GP,KH	3593	200/2,000		50
Elantra GT Except for Korean Manufactured Vehicles	13-16	25	SQ1	1-1/4	24905	0	HM	3594	200/2,000		25
Entourage	07-09	45	RT3	2	75421	0	HM,JR		350/3,500	400/4,000	20
Genesis 4 Dr. Sedan	09-11	30	SQ2	1-1/4	36486		HM,JR,KH	36065	300/3,500		60
Genesis 2 Dr. Coupe	10-12										
Genesis 4 Dr. Sedan	12-14	30	SQ2	1-1/4	36486		HM,JR,KH	36065	300/3,500		60
Genesis 4 Dr. Sedan Excluding AWD	15-15	30	SQ2	1-1/4	36486		HM,JR,KH	36065	300/3,500		60
Santa Fe	01-06	25	RT3	2	41543	0	GP,JR		315/3,500		35
Santa Fe	07-09	37	SQ3	2	75471	0	TG		525/3,500		20
Santa Fe	10-12	30	SQ2	1-1/4	36511	0	HM	36051	300/3,500		15
Santa Fe		25	SQ3	2	75684	0	HM		350/3,500	500/5,000	15
Santa Fe (6/7 Passenger)	13-17	33	RT3	2	75776	0	FP,GP,J		750/5,000	750/7,500	30
Santa Fe Sport (5 Passenger)	13-16	29	RT2	1-1/4	36536	0	HM,J,JR,SV	36051	300/3,500		30
Santa Fe Sport (5 Passenger)		31	RT3	2	75772	0	HM,J,JR,SV		525/3,500	525/5,250	30
Santa Fe Sport (5 Passenger), w/Factory Tow Package	13-16										
Santa Fe Sport (5 Passenger)	17-17	29	RT2	1-1/4	36536	0	HM,J,JR,SV	36051	300/3,500		30
Santa Fe Sport (5 Passenger)		31	RT3	2	75772	0	HM,J,JR,SV		525/3,500	525/5,250	30
Sonata	02-05	31	SQ1	1-1/4	24713	0	HM	3593	200/2,000		15
Sonata	06-09	24	SQ1	1-1/4	24757	0	HM	3592	200/2,000		20
Sonata	10-10	24	SQ1	1-1/4	24757	0	HM	3592	200/2,000		20
Sonata Except Hybrid	11-13	20	SQ1	1-1/4	24853	0	HM,JR,KH	3593	200/2,000		30
Sonata Except Hybrid	11-14	19	SQ1	1-1/4	24940	0	HM,JR,KH,SV	3593	200/2,000		40

- | | | | |
|----|---|----|--|
| EP | Fascia trimming may be required. | KH | Minor heat shield modification may be required. |
| FP | Spare tire repositioning and/or modification of spare tire carrier may be required. | SV | Trimming or removal of under body appearance panel may be required. |
| GP | Hitch crosstube concealed behind bumper. | TA | Trunk access required for hitch installation. |
| HM | Hitch crosstube is visible beneath bumper. | TG | Hitches produced before 05/13/11 are rated at 350/3500 WC. |
| J | Under vehicle spare tire stowage is retained. | TK | Hitches produced before 09/09/11 are rated at 500/5000 WC & 600/6000 WD. |
| JR | Exhaust must be temporarily lowered for installation. | X | Minor fascia trimming required. |

RECEIVER HITCH APPLICATION GUIDE

T-ONE						TOW HARNESS						4-FLAT WIRING				REQ. 4 FLAT WIRING			BRAKE CONTROL HARNESS	IN	
PC	T-ONE	FN	IN	AMP	CP	PC	TOW HARN	FN	IN	AMP	CP	TYPE	ELEC	POS	CHOICE 1	CHOICE 2	6-WAY ADAPTER	7-WAY ADAPTER			7-WAY HARDWIRE
HONDA (Continued)																					
E25	118558	BN,CH	30	4,2,7.5	X	E30	118265	BN,CH	30	4,2,7.5	X	7-Way	B,E	SUV3,5	119148	119180				3070-P	5
E18	118679	BN,CH	45	4,2,7.5	X								B	SUV3	119130	119178	20320	20321	20224		
E15	118400	BN,CG	10	2,1,5	X								B	PU1,2	119130	119178	20320	20321	20224	3070-P	5
HUMMER																					
						E8	118384 20119 20047 118015	BN,RD RD RD RD	5 10 5 10	7.5		4-Flat Both 7-Way 7-Way	H	SUV6	119180	20252				3015-P	5
E8	118384	BN,RD	5	7.5		E8	118384 20119 20047 118015	BN,RD RD RD RD	5 10 5 10	7.5		4-Flat Both 7-Way 7-Way	A A	SUV6 SUV6	119180 119180	20252 20252	20320	20321	20224		
E8	118384	BN,RD	5	7.5		E8	118384 20119 20047 118015	BN,RD RD RD RD	5 10 5 10	7.5		4-Flat Both 7-Way 7-Way	A	SUV6	119180	20252					
HYUNDAI																					
													B	PC3,4	119130	119178					
													B	PC1,2	119130	119178					
													B	PC1,2	119130	119178					
E16	118559	CH	45	2,1,5,6	X								B,E	PC3,4	119148	119180					
													B,E	PC3,4	119148	119180					
E10	118413	HG	20	2,1,4,2									B,E	PC3,4	119148	119180					
E15	118595	CH	45	2,1,5,6	X								B,E	PC3,4	119148	119180					
													B	PC3,4	119130	119178					
													B	PC3,4	119130	119178					
E12	118433	CG	10	2,1,5	X								B	PC3,4	119130	119178					
E11	118473	CG	15	2,1,7,5	X								B	PC3,4	119130	119178					
E16	118532	CH	45	2,1,5,6	X								B,E	PC3,4	119148	119180					
E16	118532	CH	45	2,1,5,6	X								B,E	PC3,4	119148	119180					
E16	118532	CH	45	2,1,5,6	X								B,E	PC3,4	119148	119180					
													B,E	PC3,4	119148	119180					
													B,E	PC3,4	119148	119180					
E19	118410	BN,CH	45	2,1,5,6	X								B,E	SUV1,2	119148	119180	20320	20321	20224		
E15	118476	CH	15	2,1,5,6	X								B,E	PC3,4	119148	119180					
E16	118522	CH	45	2,1,5,6	X								B,E	PC3,4	119148	119180					
													B,E	PC3,4	119148	119180					
													B	SUV3,4	119130	119178	20320	20321	20224		
E12	118415	CG	20	2,1,5	X	E14	118258	CH	25	2,1,5,6	X	4-Flat	B	SUV3,4	119130	119178	20320	20321	20224		
E12	118415	CG	20	2,1,5	X	E14	118258	CH	25	2,1,5,6	X	4-Flat	B,E	SUV5	119148	119180	20320	20321	20224		
E13	118269		20	4,2,7,5	X								B,E	SUV1,2	119148	119180	20320	20321	20224		
E18	118571	BN,CH	45	4,2,7,5	X	E13	118269	BN,CH	20	4,2,7,5	X	4-Flat	B,E	SUV1,2	119148	119180	20320	20321	20224		
E13	118269	BN,CH	20	4,2,7,5	X								B,E	SUV5	119148	119180					
													B	PC3,4	119130	119178					
E12	118433	CG	10	2,1,5	X								B	PC3,4	119130	119178					
E16	118557	CH	45	4,2,7,5	X								B,E	PC3,4	119148	119180					
E16	118557	CH	45	4,2,7,5	X								B,E	PC3,4	119148	119180					
E16	118557	CH	45	4,2,7,5	X								B,E	PC3,4	119148	119180					

- A** 2 wire system.
- B** 3 wire system. Converter required.
- BN** Exterior mounted plug on some or all models. May require an aftermarket electrical mounting box or bracket. (Sold separately)
- CG** T-One incorporates circuit protected taillight converter.
- CH** T-One is equipped with circuit protected ModuLite® module.
- E** ModuLite® required.
- H** 3 wire system with OEM standard 2 wire harness.
- HG** T-One incorporates taillight converter.
- RD** For vehicles equipped with factory tow package may require additional components or may be used as a replacement harness.

- RT2** Round Tube Class II 1-1/4"
- RT3** Round Tube Class III 2"
- SQ1** Square Tube Class I
- SQ2** Square Tube Class II
- SQ3** Square Tube Class III
- SQ4** Square Tube Class IV

RECEIVER HITCH APPLICATION GUIDE

MODEL / STYLE	YEAR	TRAILER HITCHES									
		PC	REC TYPE	REC SIZE	PART #	NO DRILL	FOOTNOTES	OPTIONAL DRAWBAR	WC (LBS.)	WD (LBS.)	IN
HYUNDAI (Continued)											
Sonata Hybrid	11-13	20	SQ1	1-1/4	24853	0	HM,JR,KH	3593	200/2,000		30
Sonata Hybrid	11-14	19	SQ1	1-1/4	24940	0	HM,JR,KH,SV	3593	200/2,000		40
Sonata Except Hybrid	14-14	20	SQ1	1-1/4	24853	0	HM,JR,KH,SV	3593	200/2,000		30
Sonata Hybrid	14-14	20	SQ1	1-1/4	24853	0	HM,JR,KH,SV	3593	200/2,000		30
Sonata Except Hybrid	15-17	20	SQ1	1-1/4	24853	0	HM,JR,KH,SV	3593	200/2,000		30
		19	SQ1	1-1/4	24940	0	HM,JR,KH,SV	3593	200/2,000		40
Sonata Hybrid	15-15	20	SQ1	1-1/4	24853	0	HM,JR,KH,SV	3593	200/2,000		30
Sonata Hybrid	15-16	19	SQ1	1-1/4	24940	0	HM,JR,KH,SV	3593	200/2,000		40
Tiburon	03-08	25	SQ1	1-1/4	24726		TA,HM	3592	200/2,000		45
Tucson	05-09	32	SQ2	1-1/4	36363	0	GP,JR	36051	300/3,500		25
		30	SQ3	2	75561	0	GP,JR		350/3,500		25
Tucson	10-15	21	SQ2	1-1/4	36510	0	GP,JR	36051	300/3,500		20
		23	SQ3	2	75717	0	GP,JR		525/3,500	525/5,250	20
Tucson	16-17	26	RT2	1-1/4	36572	0	GP,JR		300/3,500		30
		28	SQ3	2	75836	0	GP,JR		525/3,500		30
Veracruz	07-12	53	SQ3	2	75532	0	HM,JR		500/5,000	500/5,000	30
INFINITI											
FX35	09-12	38	RT3	2	75778	0			400/4,000		40
FX37	13-13	38	RT3	2	75778		HM		400/4,000		40
FX50	09-13	38	RT3	2	75778		HM		400/4,000		40
G35 4 Dr. Sedan	07-08	11	SQ1	1-1/4	24831		EP,GP	3593	200/2,000		45
G37 4 Dr. Sedan	09-13	11	SQ1	1-1/4	24831		EP,GP	3593	200/2,000		45
I30	96-99	34	SQ1	1-1/4	24686		TA,GP	3593	200/2,000		30
I30	00-01	34	SQ1	1-1/4	24686		TA,GP	3592	200/2,000		30
I35	02-04	34	SQ1	1-1/4	24686		TA,GP	3592	200/2,000		30
JX35	13-13	21	SQ3	2	76031	0	HM		900/6,000	900/6,000	25
Q50	14-17	27	SQ1	1-1/4	24931		GP,JR	3592	200/2,000		40
QX4	97-03	39	SQ2	1-1/4	36222	0	HM	36071	300/3,500		20
		34	RT3	2	75077	0			500/5,000	550/5,500	20
QX56	04-10	38	RT4	2	75741	0	HM		600/6,000	1,000/10,000	15
QX56 w/Factory 7-Way	04-12										
QX60	14-15	21	SQ3	2	76031	0	HM		900/6,000	900/6,000	25
QX60	16-17	21	SQ3	2	76031	0	HM		900/6,000	900/6,000	25
QX70	14-16	38	RT3	2	75778		HM		400/4,000		40
ISUZU											
Amigo w/Door Mounted Spare	98-00	29	SQ2	1-1/4	36247	0	GP	36053	300/3,500		15
Ascender w/Factory 7-Way	03-08										
Axiom w/Under Vehicle Spare	02-03	30	RT3	2	75093				350/3,500	500/5,000	20
D-Max	13-13	51	SQ3	2	75792	0	GP		600/4,000	600/6,000	20
Hombre w/Step Bumper	96-97	34	SQ2	1-1/4	36248	0	GU,HM,RH	36071	300/3,500		35
		34	SQ3	2	75051	0	GP,GU		350/3,500	750/6,000	40
Hombre w/Step Bumper	98-00	34	SQ2	1-1/4	36248	0	GU,RH,GP	36071	300/3,500		35
		30	SQ3	2	75085	0			350/3,500	750/6,000	40
		50	SQ3	2	37136		AF,CN,GU,ST		500/5,000	600/6,000	40
I-280	06-06	23	SQ4	2	75607	0	GP		600/6,000	750/7,500	25
I-290	07-08	23	SQ4	2	75607	0	GP		600/6,000	750/7,500	25
I-350	06-06	23	SQ4	2	75607	0	GP		600/6,000	750/7,500	25
I-370	07-08	23	SQ4	2	75607	0	GP		600/6,000	750/7,500	25
MU-X	13-15	35	SQ4	2	75220	0	DU,EP		600/6,000	600/6,000	45

AF Hitch is ONLY rated for Weight Carrying at 3500 lbs. GTW / 350 lbs. TW and DO NOT use Weight Distribution Spring Bars for this Specific Vehicle. Except for long bed pickups.

CN Requires OEM factory bumper for hitch installation.

DU Fascia removal required.

EP Fascia trimming may be required.

GP Hitch cross-tube concealed behind bumper.

GU Will not fit vehicles with factory or aftermarket lower Fascia/Rollpan or Tube Bumper.

HM Hitch cross-tube is visible beneath bumper.

JR Exhaust must be temporarily lowered for installation.

KH Minor heat shield modification may be required.

RH Optional drawbar #36051 required (Sold separately) except for models with ZR2 & Highrider package.

ST Will not fit 2WD models with short bed.

SV Trimming or removal of under body appearance panel may be required.

TA Trunk access required for hitch installation.

RECEIVER HITCH APPLICATION GUIDE

T-ONE						TOW HARNESS						4-FLAT WIRING				REQ. 4 FLAT WIRING		7-WAY HARDWIRE	BRAKE CONTROL HARNESS	IN	
PC	T-ONE	FN	IN	AMP	CP	PC	TOW HARN	FN	IN	AMP	CP	TYPE	ELEC	POS	CHOICE 1	CHOICE 2	6-WAY ADAPTER				7-WAY ADAPTER
HYUNDAI (Continued)																					
E14	118663		45	4.2,7.5	X								B,E	PC3,4	119148	119180					
E14	118663		45	4.2,7.5	X								B,E	PC3,4	119148	119180					
E16	118557	CH	45	4.2,7.5	X								B,E	PC3,4	119148	119180					
E14	118663		45	4.2,7.5	X								B,E	PC3,4	119148	119180					
E15	118644	CH	45	2.1,5.6	X								B,E	PC3,4	119148	119180					
E14	118663		45	4.2,7.5	X								B,E	PC3,4	119148	119180					
E14	118663		45	4.2,7.5	X								B,E	PC3,4	119148	119180					
E16	118397	CG	30	2.1,5	X								B	PC3,4	119130	119178					
E16	118397	CG	30	2.1,5	X								B	SUV1,2	119130	119178	20320	20321	20224		
E18	118501	CH	30	2.1,5.6	X								B,E	SUV1,2	119148	119180	20320	20321	20224		
E18	118501	CH	30	2.1,5.6	X								B,E	SUV1,2	119148	119180					
E13	118269	BN,CH	20	4.2,7.5	X								B,E	SUV7	119148	119180	20320	20321	20224		
INFINITI																					
E16	118593	CH	45	4.2,7.5	X								B,E	SUV3,4	119148	119180	20320	20321	20224		
E16	118593	CH	45	4.2,7.5	X								B,E	SUV3,4	119148	119180	20320	20321	20224		
E16	118593	CH	45	4.2,7.5	X								B,E	SUV3,4	119148	119180	20320	20321	20224		
E15	118480	CH	45	2.1,5.6	X								B,E	PC3,4	119148	119180					
E15	118480	CH	45	2.1,5.6	X								B,E	PC3,4	119148	119180					
													E	PC3,4	119180	119148					
													B	PC3,4	119130	119178					
													B	PC3,4	119130	119178					
													B,E	SUV1,2	119148	119180					
													B,E	PC3,4	119148	119180					
E8	118361	HG	20	2.1,5									B	SUV1,2	119130	119178	20320	20321	20224		
						E8	118384	BN,RD	5	7.5		4-Flat	A	SUV6	119180	20252	20320	20321	20224	3050-P	5
							20119	RD	10			Both	H	SUV6	119180	20252					
							118015	RD	10			7-Way									
E20	118670	BN	30	7.5		E23	118273	BN,RD	20	10		7-Way	B,E	SUV1,2	119148	119180	20320	20321	20224		
													B,E	SUV1,2	119148	119180	20320	20321	20224		
													B,E	SUV3,4	119148	119180	20320	20321	20224		
ISUZU																					
E17	118360	BN,HG	15	2.1,5									B	SUV1,2	119130	119178					
						E8	118384	BN,RD	5	7.5		4-Flat	H	SUV6	119180	20252					
							20119	RD	10			Both									
							20047	RD	5			7-Way									
							118015	RD	10			7-Way									
													B	SUV1,2	119130	119178	20320	20321	20224		
													B,E	PU1,2	119148	119180	20320	20321			
E3	118312	BN	5	7.5									A	PU3	119180	20252	20320	20321	20224		
E4	118359	BN	5	7.5									A	PU3	119180	20252	20320	20321	20224		
E10	118301	BN,CG	10	2.1,5	X								B	PU3	119130	119178	20320	20321	20224		
E10	118301	BN,CG	10	2.1,5	X								B	PU3	119130	119178	20320	20321	20224		
E10	118301	BN,CG	10	2.1,5	X								B	PU3	119130	119178	20320	20321	20224		
E10	118301	BN,CG	10	2.1,5	X								B	PU3	119130	119178	20320	20321	20224		
													B,E	SUV1,2	119148	119180					

- A** 2 wire system.
- B** 3 wire system. Converter required.
- BN** Exterior mounted plug on some or all models. May require an aftermarket electrical mounting box or bracket. (Sold separately)
- CG** T-One incorporates circuit protected taillight converter.
- CH** T-One is equipped with circuit protected ModuLite® module.
- E** ModuLite® required.
- H** 3 wire system with OEM standard 2 wire harness.
- HG** T-One incorporates taillight converter.
- RD** For vehicles equipped with factory tow package may require additional components or may be used as a replacement harness.

- RT2** Round Tube Class II 1-1/4"
- RT3** Round Tube Class III 2"
- RT4** Round Tube Class IV 2"
- SQ1** Square Tube Class I
- SQ2** Square Tube Class II
- SQ3** Square Tube Class III
- SQ4** Square Tube Class IV

RECEIVER HITCH APPLICATION GUIDE

MODEL / STYLE	YEAR	TRAILER HITCHES									
		PC	REC TYPE	REC SIZE	PART #	NO DRILL	FOOTNOTES	OPTIONAL DRAWBAR	WC (LBS.)	WD (LBS.)	IN
ISUZU (Continued)											
Oasis	96-99	35	SQ2	1-1/4	36204		HM,JR	36051	300/3,500		30
Rodeo	92-97	39	SQ3	2	75049	0			500/5,000		40
Rodeo w/Door Mounted Spare	98-01	29	SQ2	1-1/4	36247	0	GP	36053	300/3,500		15
		34	SQ3	2	75092	0			350/3,500	500/5,000	15
Rodeo w/Under Vehicle Spare, Except w/3.5L	98-04	30	RT3	2	75093	0			350/3,500	500/5,000	15
Rodeo Sport 2 Dr., w/Door Mounted Spare	01-03	29	SQ2	1-1/4	36247	0	GP	36053	300/3,500		15
Trooper	92-02	41	SQ3	2	75043		HM		500/5,000	750/7,500	40
JEEP											
Cherokee	97-01	34	SQ2	1-1/4	36260	0	GP	36071	300/3,500		30
		30	SQ3	2	75054		GP		350/3,500	550/5,500	40
		50	SQ3	2	37136				500/5,000	600/6,000	45
Cherokee	14-17	30	SQ3	2	75998	0	EP,GP		500/5,000	500/5,000	60
Cherokee Trailhawk	14-15	35	RT3	2	75838	0	HM		600/5,000	600/6,000	30
Commander	06-10	18	SQ2	1-1/4	36362	0	GP	36051	300/3,500		20
		19	SQ3	2	75338	0	TL		750/5,000	750/7,500	20
Commander w/Factory 7-Way	06-10										
Compass	07-10	22	SQ2	1-1/4	36423	0	GP	36061	300/3,500		15
		23	SQ3	2	75712	0	GP,TU		525/3,500		15
Compass Rallye Edition	07-10	22	SQ2	1-1/4	36423	0	EP,GP	36061	300/3,500		30
		23	SQ3	2	75712	0	EP,GP,TU		525/3,500		30
Compass	11-17	22	SQ2	1-1/4	36423	0	EP,GP	36061	300/3,500		30
		23	SQ3	2	75712	0	EP,GP,TU		525/3,500		30
Grand Cherokee	94-98	50	SQ3	2	37136				500/5,000	600/6,000	35
		30	SQ3	2	75041	0	GP		500/5,000	750/7,500	40
Grand Cherokee	99-99	37	SQ2	1-1/4	36276	0	HM	36051	300/3,500		15
		31	SQ3	2	75139	0			500/5,000	750/7,500	15
Grand Cherokee	00-04	37	SQ2	1-1/4	36276	0	HM	36051	300/3,500		15
		31	SQ3	2	75139	0			500/5,000	750/7,500	15
Grand Cherokee w/Factory 7-Way	00-04										
Grand Cherokee Except SRT-8	05-06	18	SQ2	1-1/4	36362	0	AI,GP	36051	300/3,500		90
		19	SQ3	2	75338	0	AI,TL		750/5,000	750/7,500	90
Grand Cherokee Except SRT-8 & w/OEM Tow Hook, w/Factory 7-Way	05-10										
Grand Cherokee w/OEM Tow Hook, w/Factory 7-Way	05-10										
Grand Cherokee Except SRT-8	07-10	18	SQ2	1-1/4	36362	0	AI,GP	36051	300/3,500		90
		19	SQ3	2	75338	0	AI,TL		750/5,000	750/7,500	90
Grand Cherokee Except w/OEM Tow Hook	11-13	21	SQ3	2	75699	0	GP		500/5,000	750/7,500	20
Grand Cherokee w/Factory 7-Way	11-12										
Grand Cherokee w/OEM Tow Hook	11-13	21	SQ3	2	75699	0	AI,GP		500/5,000	750/7,500	40
Grand Cherokee EcoDiesel	14-17	25	RT4	2	75713	0	CS,HM		600/6,000	750/7,500	20
Grand Cherokee Except w/OEM Tow Hook or ECODiesel Engine	14-17	21	SQ3	2	75699	0	GP		500/5,000	750/7,500	20
Grand Cherokee w/OEM Tow Hook, Except w/ECODiesel Engine	14-17	21	SQ3	2	75699	0	AI,GP		500/5,000	750/7,500	40
Liberty	02-04	37	SQ2	1-1/4	36303	0	GP	36071	300/3,500		15
		50	SQ3	2	37136				500/5,000	600/6,000	35
		23	SQ3	2	75128	0	GP,TM		750/5,000	750/7,500	15
Liberty	05-07	37	SQ2	1-1/4	36303	0	GP	36071	300/3,500		15
		50	SQ3	2	37136				500/5,000	600/6,000	35
		23	SQ3	2	75128	0	GP,TM		750/5,000	750/7,500	15
Liberty w/Factory 7-Way	05-08										
Liberty	08-08	31	SQ2	1-1/4	36451	0	HM	36071	300/3,500		15
		36	RT3	2	75578	0	HM		500/5,000	750/7,500	20

- AI** Additional installation time may be required.
- CS** Will fit with full-size spare tire stowed under vehicle.
- EP** Fascia trimming may be required.
- GP** Hitch crosstube concealed behind bumper.
- HM** Hitch crosstube is visible beneath bumper.

- JR** Exhaust must be temporarily lowered for installation.
- TL** Hitches produced before 10/31/11 are rated at 500/5000 WC & 750/7500 WD.
- TM** Hitches produced before 01/04/12 are rated at 500/5000 WC & 750/7500 WD.
- TU** Hitches produced before 07/24/12 are rated at 350/3500 WC.

RECEIVER HITCH APPLICATION GUIDE

T-ONE						TOW HARNESS						4-FLAT WIRING				REQ. 4 FLAT WIRING		7-WAY HARDWIRE	BRAKE CONTROL HARNESS	IN
PC	T-ONE	FN	IN	AMP	CP	PC	TOW HARN	FN	IN	AMP	CP	TYPE	ELEC	POS	CHOICE 1	CHOICE 2	6-WAY ADAPTER			
ISUZU (Continued)																				
E5	118336	HG	5	2.1,5									B	SUV3	119130	119178				
E5	118331	BN,HG	5	2.1,5									B	SUV1,2	119130	119178	20320	20321	20224	
E17	118360	BN,HG	15	2.1,5									B	SUV1,2	119130	119178	20320	20321	20224	
E17	118360	BN,HG	15	2.1,5									B	SUV1,2	119130	119178	20320	20321	20224	
E17	118360	BN,HG	15	2.1,5									B	SUV1,2	119130	119178	20320	20321	20224	
E5	118339	BN,HG	5	2.1,5									B	SUV5	119130	119178	20320	20321	20224	
JEEP																				
E7	118354	HG	20	2.1,5									B	SUV3	119130	119178	20320	20321	20224	
E18	118605	CH,BN	45	4.2,7.5	X								A,E	SUV1,2	119148	119180	20320	20321	20224	3014-P 5
E18	118605	CH,BN	45	4.2,7.5	X								A,E	SUV1,2	119148	119180	20320	20321	20224	3014-P 5
E16	118408	BN,CG	15	2.1,5	X	E3	118381	BN,RD	5	7.5		4-Flat	B	SUV1,2	119130	119178	20320	20321	20224	
							20135	RD	10			Both	H	SUV6	119180	20252				
E18	118428	BN,CH	45	2.1,4.2	X								B,E	SUV1,2	119148	119180	20320	20321	20224	
E18	118428	BN,CH	45	2.1,4.2	X								B,E	SUV1,2	119148	119180	20320	20321	20224	
E20	118539	BN,CH	45	4.2,7.5	X								B,E	SUV1,2	119148	119180	20320	20321	20224	
E16	118349	CH,JM	45	2.1,4.2									B,E	SUV3,4	119148	119180	20320	20321	20224	
E10	118369	CH	10	2.1,4.2									B,E	SUV3,4	119148	119180	20320	20321	20224	
E10	118369	CH	10	2.1,4.2		E3	118381	BN,RD	5	7.5		4-Flat	B,E	SUV3,4	119148	119180	20320	20321	20224	
							20135	RD	10			Both	H	SUV6	119180	20252				
E17	118394	BN,CG	20	2.1,5	X	E3	118381	BN,RD	5	7.5		4-Flat	B	SUV1,2	119130	119178	20320	20321	20224	
							20135	RD	10			Both	H	SUV6	119180	20252				
							20135	RD	10			Both	H	SUV6	119180	20252				
E7	118425	BN	20	7.5		E3	118381	BN,RD	5	7.5		4-Flat	A	SUV1,2	119180	20252	20320	20321	20224	
E7	118425	BN	20	7.5		E8	118384	BN,RD	5	7.5		4-Flat	A	SUV1,2	119180	20252	20320	20321	20224	3045-P 5
							20119	RD	10			Both	H	SUV6	119180	20252				
							118015	RD	10			7-Way								
E7	118425	BN	20	7.5		E8	118384	BN,RD	5	7.5		4-Flat	A	SUV1,2	119180	20252	20320	20321	20224	3045-P 5
E18	118605	CH,BN	45	4.2,7.5	X								A,E	SUV1,2	119148	119180	20320	20321	20224	3045-P 5
													A,E	SUV3,4	119148	119180	20320	20321	20224	3045-P 5
													A,E	SUV3,4	119148	119180	20320	20321	20224	3045-P 5
E20	118524	HG	45	4.2,7.5	X								B	SUV1,2	119130	119178	20320	20321	20224	
E20	118524	HG	45	4.2,7.5	X	E3	118381	BN,RD	5	7.5		4-Flat	B	SUV1,2	119130	119178	20320	20321	20224	
							20135	RD	10			Both	H	SUV6	119180	20252				
E19	118554	BN,CH	45	4.2,7.5	X	E3	118381	BN,RD	5	7.5		4-Flat	B,E	SUV1,2	119148	119180	20320	20321	20224	

- A** 2 wire system.
- B** 3 wire system. Converter required.
- BN** Exterior mounted plug on some or all models. May require an aftermarket electrical mounting box or bracket. (Sold separately)
- CG** T-One incorporates circuit protected taillight converter.
- CH** T-One is equipped with circuit protected ModuLite® module.
- E** ModuLite® required.
- H** 3 wire system with OEM standard 2 wire harness.
- HG** T-One incorporates taillight converter.
- JM** Some early production 1994 models may require #118348.
- RD** For vehicles equipped with factory tow package may require additional components or may be used as a replacement harness.

- RT3** Round Tube Class III 2"
- RT4** Round Tube Class IV 2"
- SQ2** Square Tube Class II
- SQ3** Square Tube Class III

RECEIVER HITCH APPLICATION GUIDE

MODEL / STYLE	YEAR	TRAILER HITCHES									
		PC	REC TYPE	REC SIZE	PART #	NO DRILL	FOOTNOTES	OPTIONAL DRAWBAR	WC (LBS.)	WD (LBS.)	IN
JEEP (Continued)											
Liberty	09-12	31 36	SQ2 RT3	1-1/4 2	36451 75578	0 0	HM HM	36071	300/3,500 500/5,000		15 20
Liberty w/Factory 7-Way	09-12										
Patriot	07-07	22 23	SQ2 SQ3	1-1/4 2	36423 75712	0 0	GP GP,TU	36061	300/3,500 525/3,500		15 15
Patriot	08-17	22 23	SQ2 SQ3	1-1/4 2	36423 75712	0 0	EP,GP EP,GP,TU	36061	300/3,500 525/3,500		30 30
Renegade	15-16	27 26	RT2 RT3	1-1/4 2	36587 76021		HM HM,JR	36071	300/3,500 675/4,500		30 40
TJ (Canada Only)	97-97	27 29 31 28	SQ1 SQ2 SQ3 RT3	1-1/4 1-1/4 2 2	24631 36238 41531 75193	0 0 0 0	DA,HM HM HM HM,TD	3590 36071	200/2,000 300/3,500 300/3,500 400/4,000		15 15 15 15
TJ (Canada Only)	98-06	27 29 31 28	SQ1 SQ2 SQ3 RT3	1-1/4 1-1/4 2 2	24631 36238 41531 75193	0 0 0 0	DA,HM HM HM HM,TD	3590 36071	200/2,000 300/3,500 300/3,500 400/4,000		15 15 15 15
Wrangler	97-97	27 29 31 28	SQ1 SQ2 SQ3 RT3	1-1/4 1-1/4 2 2	24631 36238 41531 75193	0 0 0 0	DA,HM HM HM HM,TD	3590 36071	200/2,000 300/3,500 300/3,500 400/4,000		15 15 15 15
Wrangler	98-06	27 29 31 28	SQ1 SQ2 SQ3 RT3	1-1/4 1-1/4 2 2	24631 36238 41531 75193	0 0 0 0	DA,HM HM HM HM,TD	3590 36071	200/2,000 300/3,500 300/3,500 400/4,000		15 15 15 15
Wrangler	07-17	11	SQ3	2	76104	0			675/4,500	675/4,500	20
Wrangler Except w/Right Hand Drive, Hard Rock Edition, 75th Anniversary Edition & vehicles with Mopar Off Road Bumper #82213654	07-17	27 10	SQ2 SQ3	1-1/4 2	36424 75515	0 0	GP	36071	300/3,500 675/4,500		20 20
Wrangler Right Hand Drive, Except Hard Rock Edition, 75th Anniversary Edition & vehicles with Mopar Off Road Bumper #82213654	07-17	27 10	SQ2 SQ3	1-1/4 2	36424 75515	0 0	GP	36071	300/3,500 675/4,500	675/4,500	20 20
KIA											
Borrego w/Factory 7-Way	09-11										
Cadenza	14-14	28	RT2	1-1/4	36544		HM,JR	36061	300/3,500		20
Forte 4 Dr. Sedan	10-13	27	SQ1	1-1/4	24846	0	HM,JR	3594	200/2,000		20
Forte 4 Dr. Sedan	14-17	24	SQ1	1-1/4	24903	0	HM	3594	200/2,000		20
Magentis (Canada Only)	01-04	44	SQ1	1-1/4	24709	0	GP	3593	200/2,000		15
Magentis (Canada Only)	06-10	29	SQ1	1-1/4	24778	0	HM,JR	3594	200/2,000		20
Optima	01-06	44	SQ1	1-1/4	24709	0	GP	3593	200/2,000		15
Optima (App. starts with 2006-1/2)	06-08	29	SQ1	1-1/4	24778	0	HM,JR	3594	200/2,000		20
Optima	09-10	29	SQ1	1-1/4	24778	0	HM,JR	3594	200/2,000		20
Optima	11-13	19	SQ1	1-1/4	24940	0	HM,JR,KH,SV	3593	200/2,000		40
Optima	11-15	20	SQ1	1-1/4	24853	0	HM,JR,KH	3593	200/2,000		30
Optima	14-16	19	SQ1	1-1/4	24940	0	HM,JR,KH,SV	3593	200/2,000		40
Rio	02-05	33	SQ1	1-1/4	24727		TA,GP	3594	200/2,000		20
Rio 4 Dr. Sedan	06-11	32	SQ1	1-1/4	24760	0	GP	3590	200/2,000		20
Rio 4 Dr. Sedan	12-16	30	SQ1	1-1/4	24884	0	HM	3592	200/2,000		15
Rio 5 Dr. Hatchback	12-16	28	SQ1	1-1/4	24883	0	GP,JR,SV	3593	200/2,000		30
Rio5 5 Dr. Hatchback	06-11	28	SQ1	1-1/4	24795	0	JR,X,GP	3594	200/2,000		25

DA Will not fit with tube style bumper.

EP Fascia trimming may be required.

GP Hitch crosstube concealed behind bumper.

HM Hitch crosstube is visible beneath bumper.

JR Exhaust must be temporarily lowered for installation.

KH Minor heat shield modification may be required.

SV Trimming or removal of under body appearance panel may be required.

TA Trunk access required for hitch installation.

TD Hitches without electrical bracket are rated at 350/3500 WC & No WD. Hitch with electrical bracket rated at 400/4000 WC & No WD.

TU Hitches produced before 07/24/12 are rated at 350/3500 WC.

X Minor fascia trimming required.

RECEIVER HITCH APPLICATION GUIDE

K

KIA

T-ONE						TOW HARNESS						4-FLAT WIRING				REQ. 4 FLAT WIRING		7-WAY HARDWIRE	BRAKE CONTROL HARNESS	IN
PC	T-ONE	FN	IN	AMP	CP	PC	TOW HARN	FN	IN	AMP	CP	TYPE	ELEC	POS	CHOICE 1	CHOICE 2	6-WAY ADAPTER			
JEEP (Continued)																				
E19	118554	BN,CH	45	4.2,7.5	X	E8	118384	BN,RD	5	7.5		4-Flat	B,E	SUV1,2	119148	119180	20320	20321	20224	
							20119 118015	RD RD	10 10			Both 7-Way	H	SUV6	119180	20252				
E18	118428	BN,CH	45	2.1,4.2	X								B,E	SUV1,2	119148	119180	20320	20321	20224	
E18	118552	CH	45	4.2,7.5	X								A,E	SUV1,2	119148	119180	20320	20321	20224	
E26	118651	CH	45	4.2,7.5	X								BTT	SUV3,4	119251	119191	20320	20321		
E5	118356	BN	10	7.5									A	SUV5,7	119180	20252	20320	20321	20224	
E7	118409	BN	15	7.5									A	SUV5,7	119180	20252	20320	20321	20224	
E5	118356	BN	10	7.5									A	SUV5,7	119180	20252	20320	20321	20224	
E7	118409	BN	15	7.5									A	SUV5,7	119180	20252	20320	20321	20224	
E5	118416	BN	10	7.5									A	SUV1	119180	20252	20320	20321	20224	
E5	118416	BN	10	7.5									A	SUV1	119180	20252	20320	20321	20224	
													A	SUV1,2	119180	20252	20320	20321	20224	
KIA																				
						E8	118384 20119 118015	BN,RD RD RD	5 10 10	7.5		4-Flat Both 7-Way	H	SUV6	119180	20252				
E15	118616	CH	45	2.1,5.6	X								B,E	PC3,4	119148	119180				
E12	118415	CG	20	2.1,5	X								B	PC3,4	119130	119178				
E15	118594	CH	45	2.1,5.6	X								B,E	PC3,4	119148	119180	20320	20321	20224	
													B	PC3,4	119130	119178				
													B	PC3,4	119130	119178				
													B	PC3,4	119130	119178				
E7	118452		10	7.5									A	PC3,4	119180	20252				
E12	118433	CG	10	2.1,5	X								B	PC3,4	119130	119178				
E10	118453	HG	10	2.1,7.5									B	PC3,4	119130	119178				
E10	118453	HG	10	2.1,7.5									B	PC3,4	119130	119178				
													B	PC3,4	119130	119178				
													B	PC3,4	119130	119178				
													B	PC1,2	119130	119178				
													B,E	PC3,4	119148	119180				
													B,E	PC3,4	119148	119180				
													B	PC3,4	119130	119178				

- A** 2 wire system.
- B** 3 wire system. Converter required.
- BN** Exterior mounted plug on some or all models. May require an aftermarket electrical mounting box or bracket. (Sold separately)
- BTT** Shared Brake/Tail/Turn multiplexed wiring system. ModuLite® HD Plus or Ultra required.
- CG** T-One incorporates circuit protected taillight converter.

- CH** T-One is equipped with circuit protected ModuLite® module.
- E** ModuLite® required.
- H** 3 wire system with OEM standard 2 wire harness.
- HG** T-One incorporates taillight converter.
- RD** For vehicles equipped with factory tow package may require additional components or may be used as a replacement harness.

- RT2** Round Tube Class II 1-1/4"
- RT3** Round Tube Class III 2"
- SQ1** Square Tube Class I
- SQ2** Square Tube Class II
- SQ3** Square Tube Class III

RECEIVER HITCHES

RECEIVER HITCH APPLICATION GUIDE

MODEL / STYLE	YEAR	TRAILER HITCHES									
		PC	REC TYPE	REC SIZE	PART #	NO DRILL	FOOTNOTES	OPTIONAL DRAWBAR	WC (LBS.)	WD (LBS.)	IN
KIA (Continued)											
Rondo	07-10	27	SQ1	1-1/4	24797	0	GP, JR	3594	200/2,000		30
Rondo (Canada Only)	11-12	27	SQ1	1-1/4	24797	0	GP, JR	3594	200/2,000		30
Rondo (Canada Only)	14-16	28	SQ2	1-1/4	36525	0	GP, JR, SV	36061	300/3,500		25
Sedona	02-05	45	SQ2	1-1/4	36305		HM	36071	300/3,500		20
		42	RT3	2	75131		HM		500/5,000	550/5,500	30
Sedona 118.9" Long Wheelbase	06-12	45	RT3	2	75421	0	HM, JR		350/3,500	400/4,000	20
Sedona 113.8" Short Wheelbase	07-10	45	RT3	2	75551		HM, JR		350/3,500	400/4,000	25
Sedona 118.9" Long Wheelbase	14-14	45	RT3	2	75421	0	HM, JR		350/3,500	400/4,000	20
Sedona	15-16	40	RT3	2	75894	0	HM, JR, SV		400/4,000	400/4,000	20
Sorento	03-06	29	RT3	2	75516	0	HM		500/5,000	500/5,000	15
Sorento	07-09	29	RT3	2	75516	0	HM		500/5,000	500/5,000	15
Sorento EX V6, w/Factory Tow Package	11-13	30	SQ2	1-1/4	36511	0	HM	36051	300/3,500		15
		25	SQ3	2	75684	0	HM		350/3,500	500/5,000	15
Sorento Except SX V6 & EX V6 w/Factory Tow Package	11-13	30	SQ2	1-1/4	36511	0	HM	36051	300/3,500		15
		25	SQ3	2	75684	0	HM		350/3,500	500/5,000	15
Sorento SX V6	11-13	30	SQ2	1-1/4	36511	0	HM	36051	300/3,500		15
		25	SQ3	2	75684	0	HM		350/3,500	500/5,000	15
Sorento Except LX I4	14-15	29	RT2	1-1/4	36536	0	HM, J, JR, SV	36051	300/3,500		30
		31	RT3	2	75772	0	HM, J, JR, SV		525/3,500	525/5,250	30
Sorento LX I4	14-15	29	RT2	1-1/4	36536	0	HM, J, JR, SV	36051	300/3,500		30
		31	RT3	2	75772	0	HM, J, JR, SV		525/3,500	525/5,250	30
Sorento	16-17	36	RT3	2	75908	0	HM, TA, JR		500/5,000		40
Soul Except w/LED Taillights	10-13	13	SQ1	1-1/4	24839	0	GP, JR	3593	200/2,000		40
Soul w/LED Taillights	10-13	13	SQ1	1-1/4	24839	0	GP, JR	3593	200/2,000		40
Soul Except w/LED Taillights	14-16	19	SQ1	1-1/4	24915	0	GP, JR	3593	200/2,000		40
Soul w/LED Taillights	14-16	19	SQ1	1-1/4	24915	0	GP, JR	3593	200/2,000		40
Spectra Except Spectra5	05-09	31	SQ1	1-1/4	24743	0	JR, HM	3593	200/2,000		20
Sportage	95-97	33	SQ2	1-1/4	36266		HM	36051	300/3,500		20
Sportage	98-02	33	SQ2	1-1/4	36266		HM	36051	300/3,500		20
Sportage 4 Cyl.	05-10	32	SQ2	1-1/4	36363	0	GP, JR	36051	300/3,500		25
		30	SQ3	2	75561	0	GP, JR		350/3,500		25
Sportage 6 Cyl.	05-10	32	SQ2	1-1/4	36363	0	GP, JR	36051	300/3,500		25
		30	SQ3	2	75561	0	GP, JR		350/3,500		25
Sportage	11-16	21	SQ2	1-1/4	36510	0	GP, JR	36051	300/3,500		20
		23	SQ3	2	75717	0	GP, JR		525/3,500	525/5,250	20
Sportage Except SX & SX Turbo	17-17	29	RT2	1-1/4	36593	0	GP, SV, JR, X	36071	300/3,500		30
		29	SQ3	2	76074	0	GP, SV, JR		675/4,500	675/4,500	25
LAND ROVER											
LR2	08-14	24	RT3	2	75688	0	HM		400/4,000	400/4,000	20
Range Rover	05-14										
Range Rover	15-15										
Range Rover Evoque Excluding Autobiography	12-14	25	SQ3	2	75227	0	EP, GP, X, KH		675/4,500		45
Range Rover Evoque Excluding Autobiography	15-16	25	SQ3	2	75227	0	EP, GP, X, KH		675/4,500		45
Range Rover Sport	14-14										
Range Rover Sport	15-16	41	SQ4	2	75229	0	GP, SV		800/8,000		45
LEXUS											
ES300 4 Dr.	97-01	36	SQ1	1-1/4	24563	0	JR, HM	3593	200/2,000		30
		23	SQ2	1-1/4	36336		HM		36061	300/3,500	
ES300 4 Dr.	02-03	23	SQ2	1-1/4	36336		HM	36061	300/3,500		15
ES330 4 Dr.	04-06	23	SQ2	1-1/4	36336		HM	36061	300/3,500		15
ES350	07-11	20	SQ2	1-1/4	36416		GP, JR, TA	36071	300/3,500		45
ES350	12-12	20	SQ2	1-1/4	36416			36071	300/3,500		45
ES350 Except Hybrid	13-17	29	SQ2	1-1/4	36530		HM, JR	36071	300/3,500		40

EP Fascia trimming may be required.
 GP Hitch crosstube concealed behind bumper.
 HM Hitch crosstube is visible beneath bumper.
 J Under vehicle spare tire storage is retained.
 JR Exhaust must be temporarily lowered for installation.

KH Minor heat shield modification may be required.
 SV Trimming or removal of under body appearance panel may be required.
 TA Trunk access required for hitch installation.
 X Minor fascia trimming required.

RECEIVER HITCH APPLICATION GUIDE

T-ONE						TOW HARNESS						4-FLAT WIRING				REQ. 4 FLAT WIRING		BRAKE CONTROL HARNESS	IN	
PC	T-ONE	FN	IN	AMP	CP	PC	TOW HARN	FN	IN	AMP	CP	TYPE	ELEC	POS	CHOICE 1	CHOICE 2	6-WAY ADAPTER			7-WAY ADAPTER
KIA (Continued)																				
E14	118431	BN,CG	15	2.1,5	X								B	SUV1,2	119130	119178	20320	20321		
E14	118431	BN,CG	15	2.1,5	X								B	SUV1,2	119130	119178	20320	20321		
E8	118309	HG	25	2.1,5									B,E	SUV1,2	119148	119180	20320	20321		
													B	SUV1,2	119130	119178	20320	20321	20224	
E19	118410	BN,CH	45	2.1,5.6	X								B,E	SUV1,2	119148	119180	20320	20321	20224	
E19	118410	BN,CH	45	2.1,5.6	X								B,E	SUV1,2	119148	119180	20320	20321	20224	
E19	118410	BN,CH	45	2.1,5.6	X								B,E	SUV1,2	119148	119180	20320	20321	20224	
													B,E	SUV5	119148	119180	20320	20321	20224	
E7	118307	BN,HG	5	2.1,5									B	SUV7	119130	119178	20320	20321	20224	
						E13	118269	CH,RD	20	4.2,7.5	X	4-Flat	B,E	SUV7	119148	119180	20320	20321	20224	
						E13	118269	BN,CH	20	4.2,7.5	X	4-Flat	B,E	SUV1,2	119148	119180	20320	20321	20224	
E23	118506	CH	45	4.2,7.5	X								B,E	SUV1,2	119148	119180	20320	20321	20224	
E13	118269	BN,CH	20	4.2,7.5	X	E13	118269	BN,CH	20	4.2,7.5	X	4-Flat	B,E	SUV1,2	119148	119180	20320	20321	20224	
						E13	118269	BN,CH	20	4.2,7.5	X	4-Flat	B,E	SUV1,2	119148	119180	20320	20321	20224	
E16	118583	BN,CH	45	4.2,7.5	X								B,E	SUV1,2	119148	119180	20320	20321	20224	
													B,E	SUV5	119148	119180	20320	20321		
E14	118431	BN,CG	15	2.1,5	X								B	SUV1,2	119130	119178	20320	20321		
E17	118637	CH	45	2.1,5.6	X								B,E	SUV1,2	119148	119180	20320	20321		
E14	118431	BN,CG	15	2.1,5	X								B	SUV1,2	119130	119178	20320	20321		
E17	118637	CH	45	2.1,5.6	X								B,E	SUV1,2	119148	119180	20320	20321		
													B	PC3,4	119130	119178				
													B,E	SUV3,4	119148	119180				
		HG											B,E	SUV3,4	119148	119180				
													B	SUV1,2	119130	119178	20320	20321	20224	
E8	118401	BN,CG	5	2.1,5	X								B	SUV5	119130	119178	20320	20321	20224	
E25	118526	CH	45	4.2,7.5	X								B,E	SUV1,5	119148	119180	20320	20321	20224	
E17	118698	CH,BN	45	4.2,7.5	X								B,E	SUV1,5	119148	119180				
LAND ROVER																				
													B,E	SUV1,2	119148	119180	20320	20321	20224	
													A	SUV6	119180	20252				3035-P
E1	118681	BN	10	4.2,7.5	X	E8	118275	BN	20			7-Way	A	SUV6	119180	20252				3035-P
E1	118624	BN	10	7.5									A	SUV5	119180	20252				3035-P
													A	SUV5	119180	20252				3035-P
E1	118681		10	4.2,7.5	X								A	SUV6	119180	20252				
E1	118681		10	4.2,7.5	X	E8	118275	BN	20			7-Way	A	SUV6	119180	20252				
LEXUS																				
													E	PC3,4	119180	119148				
													E	PC3,4	119180	119148				
													E	PC3,4	119180	119148				
E16	118488	CH	45	2.1,5.6	X								B,E	PC3,4	119148	119180				
		CH											B,E	PC3,4	119148	119180				
E17	118592	CH	45	2.1,5.6	X								B,E	PC3,4	119148	119180				

A 2 wire system.
B 3 wire system. Converter required.
BN Exterior mounted plug on some or all models. May require an aftermarket electrical mounting box or bracket. (Sold separately)
CG T-One incorporates circuit protected taillight converter.

CH T-One is equipped with circuit protected ModuLite® module.
E ModuLite® required.
HG T-One incorporates taillight converter.
RD For vehicles equipped with factory tow package may require additional components or may be used as a replacement harness.

RT2 Round Tube Class II 1-1/4"
RT3 Round Tube Class III 2"
SQ1 Square Tube Class I
SQ2 Square Tube Class II
SQ3 Square Tube Class III
SQ4 Square Tube Class IV

RECEIVER HITCH APPLICATION GUIDE

MODEL / STYLE	YEAR	TRAILER HITCHES									
		PC	REC TYPE	REC SIZE	PART #	NO DRILL	FOOTNOTES	OPTIONAL DRAWBAR	WC (LBS.)	WD (LBS.)	IN
LEXUS (Continued)											
GS350	13-13	32	SQ2	1-1/4	36535	0	GP,EP,FE	36071	300/3,500		60
GS350 F Sport	13-13										
GS450h	13-13										
GX460	10-17	21	SQ3	2	75685	0			500/5,000	500/5,000	15
GX460 w/Factory 7-Way	10-11										
GX470	03-06	47	RT4	2	75155	0	LT,SI		600/6,000	730/7,300	35
GX470 w/Factory 7-Way	03-06										
GX470	07-09	47	RT4	2	75155	0	LT,SI		600/6,000	730/7,300	35
HS250h Hybrid	10-12	23	SQ1	1-1/4	248601	0	HM,JR,KH	3594	200/2,000		25
IS250	14-15	25	RT1	1-1/4	24923	0	KH,AE,HM	3594	200/2,000		35
IS350	14-16	25	RT1	1-1/4	24923	0	KH,AE,HM	3594	200/2,000		35
LX450	96-97	54	SQ3	2	41015	0	HM		500/5,000	750/6,000	30
LX470	98-99	45	SQ3	2	75095	0	GP		500/5,000	750/6,000	20
LX470	00-00	45	SQ3	2	75095	0	GP		500/5,000	750/6,000	20
LX470	01-02	45	SQ3	2	75095	0	GP		500/5,000	750/6,000	20
LX470	03-07	45	SQ3	2	75095	0	GP		500/5,000	750/6,000	20
NX200t	15-17	29	RT3	2	75956	0	JR,HM		350/3,500	400/4,000	35
NX300h	15-15										
RX300	99-00	39	SQ2	1-1/4	36271	0	HM	36051	300/3,500		15
		35	SQ3	2	41541	0	HM		300/3,500		15
RX300	01-03	39	SQ2	1-1/4	36271	0	HM	36051	300/3,500		15
		35	SQ3	2	41541	0	HM		300/3,500		15
RX330	04-06	32	RT3	2	75153	0	HM		350/3,500		20
RX350	07-09	32	RT3	2	75153	0	HM		350/3,500		20
RX350 Except F Sport	10-12	31	SQ3	2	75676	0	GP,JR,JV		400/4,000	500/5,000	30
RX350 Except F Sport	13-15	31	SQ3	2	75676	0	GP,JR,JV		400/4,000	500/5,000	30
RX350 Except F Sport	16-17	26	SQ3	2	75540	0	GP,SV		675/4,500	675/4,500	20
RX400h Hybrid	06-08	32	RT3	2	75153	0	HM		350/3,500		20
RX450h Hybrid	10-15	31	SQ3	2	75676	0	GP,JR,JV		400/4,000	500/5,000	30
RX450h	16-16	26	SQ3	2	75540	0	GP,SV		675/4,500	675/4,500	40
LINCOLN											
Aviator	03-04	51	RT3	2	75132	0	HM,KL		500/5,000	800/8,000	20
Aviator w/Factory 7-Way	03-05										
Aviator	05-05	51	RT3	2	75132	0	HM,KL		500/5,000	800/8,000	20
Continental	88-02	35	SQ1	1-1/4	24699	0	GP,JR	3592	200/2,000		20
		35	SQ2	1-1/4	36252	0	GP,JR	36063	300/3,500		20
LS	00-06	35	SQ2	1-1/4	36282		FE,GP	36071	300/3,500		30
Mark LT (Built After 8/2005)	06-08	25	SQ4	2	75506	0	CP,HM		600/6,000	1,000/10,000	20
		37	SQ5	2	41933	0	@,CP,HM		1,000/10,000	1,200/12,000	20
Mark LT (Built Before 8/2005)	06-06	56	RT4	2	41549	0	HM,KM		600/6,000	1,000/10,000	30
		50	RT4	2	75156	0	HM,KM		600/6,000	800/8,000	30
Mark LT w/Factory 7-Way	06-08										
Mark VIII	93-98	41	SQ2	1-1/4	36179	0	GP,JR	36061	300/3,500		40
MKC	15-17	37	SQ2	1-1/4	36586	0	GP,JR	36061	300/3,500		45
		34	SQ3	2	75943	0	GP,JR		525/3,500		45
MKS	09-12	30	SQ2	1-1/4	36477	0	GP,JR	36051	300/3,500		30
MKS	13-16	30	SQ2	1-1/4	36477	0	GP,JR	36051	300/3,500		30
MKT	10-11	45	RT3	2	75679	0	HM,JR		400/4,000	400/4,000	30

- @ Ultra Frame ball mount must be used to achieve maximum weight carrying rating.
- AE Requires temporary removal of muffler during installation.
- CP Fits all models without factory installed receiver.
- EP Fascia trimming may be required.
- FE Fascia trimming may be required. Allow additional installation time.
- GP Hitch crosstube concealed behind bumper.
- HM Hitch crosstube is visible beneath bumper.
- JR Exhaust must be temporarily lowered for installation.

- JV Rubber air deflector/fascia must be removed or trimmed to install hitch.
- KH Minor heat shield modification may be required.
- KL Hitch is designed to attach beneath the OEM hitch.
- KM Does not work with models originally equipped with OEM hitch.
- LT Requires removal of factory hitch if equipped.
- SI Hitches produced before 07/31/07 are rated at 350/3500 WC & 500/5000 WD.
- SV Trimming or removal of under body appearance panel may be required.

RECEIVER HITCH APPLICATION GUIDE

T-ONE						TOW HARNESS						4-FLAT WIRING				REQ. 4 FLAT WIRING			BRAKE CONTROL HARNESS	IN		
PC	T-ONE	FN	IN	AMP	CP	PC	TOW HARN	FN	IN	AMP	CP	TYPE	ELEC	POS	CHOICE 1	CHOICE 2	6-WAY ADAPTER	7-WAY ADAPTER			7-WAY HARDWIRE	
LEXUS (Continued)																						
E17	118598	CH	45	2.1,5.6	X								B,E	PC3,4	119148	119180						
E17	118598	CH	45	2.1,5.6	X								B,E	PC3,4	119148	119180						
E17	118598	CH	45	2.1,5.6	X								B,E	PC3,4	119148	119180						
						E12	118262	BN,RD	10			Both	A	SUV5	119180	20252	20320				3040-P	5
E8	118384	BN,RD	5	7.5			20119 118015	RD RD	10 10			Both 7-Way	A	SUV5	119180	20252						
													E	SUV1,2	119180	119148	20320	20321	20224	3040-P	5	
							20137	RD	10			Both	E	SUV1,2	119180	20252						
													E	SUV1,2	119180	119148	20320	20321	20224	3040-P	5	
E17	118510	CH	20	2.1,5.6	X								B,E	PC3,4	119148	119180						
													B,E	PC3,4	119148	119180						
													B,E	PC3,4	119148	119180						
E5	118357	BN,HG	5	2.1,5									B	SUV5	119130	119178	20320	20321	20224			
E5	118365	BN,HG	5	2.1,5									B	SUV6	119130	119178	20320	20321	20224			
													B	SUV6	119130	119178	20320	20321	20224			
						E3	118245	BN,RD	10	7.5		4-Flat	B	SUV6	119130	119178	20320	20321	20224			
						E3	118245	BN,RD	10	7.5		4-Flat	B	SUV6	119130	119178	20320	20321	20224	3040-P	5	
E17	118652	CH	45	4.2,7.5	X								B,E	SUV3,4	119148	119180						
E17	118652	CH	45	4.2,7.5	X								B,E	SUV3,4	119148	119180						
													E,Z	SUV1,2	119180	119148	20320	20321	20224			
						E3	118245	BN,RD	10	7.5		4-Flat	E,Z	SUV1,2	119180	119148	20320	20321	20224			
E17	118478	CH	45	2.1,5.6	X								B,E	SUV1,2	119148	119180	20320	20321	20224			
E17	118478	CH	45	2.1,5.6	X								B,E	SUV1,2	119148	119180	20320	20321	20224			
E17	118478	CH	45	2.1,5.6	X	E3	118252	BN,RD	5	7.5		4-Flat	B,E	SUV3,4	119148	119180	20320	20321	20224			
						E3	118252	BN,RD	5	7.5		4-Flat	B,E	SUV3,4	119148	119180	20320	20321	20224			
													B,E	SUV3,4	119148	119180						
													B,E	SUV1,2	119148	119180	20320	20321	20224			
E13	118255	BN,CH	20	2.1,5.6	X	E3	118252	BN,RD	5	7.5		4-Flat	B,E	SUV3,4	119148	119180	20320	20321	20224			
													B,E	SUV3,4	119148	119180						
LINCOLN																						
E5	118344	BN	10	7.5			20119 118015	RD RD	10 10			Both 7-Way	A	SUV1,2	119180	20252	20320	20321	20224			
													A	SUV6	119180	20252						
													A	SUV1,2	119180	20252	20320	20321	20224			
													A,E	PC3,4	119148	119180						
E17	118373		20	2.1,4.2									G	PC3,4		119251						
													A	PU3	119180	20252	20320	20321	20224	3035-P	5	
													A	PU3	119180	20252	20320	20321	20224	3035-P	5	
							20119 118015	RD RD	10 10			Both 7-Way	A	PU3	119180	20252						
													E	PC3,4	119180	119148						
													B,E	SUV1,2	119148	119180	20320	20321	20224			
E18	118471	CH	45	2.1,5.6	X								B,E	PC3,4	119148	119180						
E15	118599	CH	45	2.1,5.6	X								B,E	PC3,4	119148	119180						
E18	118507	CH	45	2.1,5.6	X								A,E	SUV3,4	119148	119180	20320	20321	20224	3035-P	5	

A 2 wire system.
B 3 wire system. Converter required.
BN Exterior mounted plug on some or all models. May require an aftermarket electrical mounting box or bracket. (Sold separately)
CH T-One is equipped with circuit protected ModuLite® module.
E ModuLite® required.

G Low-side switching system.
HG T-One incorporates taillight converter.
RD For vehicles equipped with factory tow package may require additional components or may be used as a replacement harness.
Z May be equipped with Factory Tow Prep Plug. Determine at time of installation.

RT1 Round Tube Class I 1-1/4"
RT3 Round Tube Class III 2"
RT4 Round Tube Class IV 2"
SQ1 Square Tube Class I
SQ2 Square Tube Class II
SQ3 Square Tube Class III
SQ4 Square Tube Class IV
SQ5 Square Tube Class V

RECEIVER HITCH APPLICATION GUIDE

MODEL / STYLE	YEAR	TRAILER HITCHES									
		PC	REC TYPE	REC SIZE	PART #	NO DRILL	FOOTNOTES	OPTIONAL DRAWBAR	WC (LBS.)	WD (LBS.)	IN
LINCOLN (Continued)											
MKT w/Factory 7-Way	10-12										
MKT	12-14	45	RT3	2	75679	0	HM,JR		400/4,000	400/4,000	30
MKT	15-16	45	RT3	2	75679	0	HM,JR		400/4,000	400/4,000	30
MKX	07-10	33	SQ2	1-1/4	36447	0	GP,JR,KH	36051	300/3,500		45
		20	SQ3	2	75992		GP,KH,JR		400/4,000	400/4,000	55
MKX	11-15	20	SQ3	2	75992		GP,KH,JR		400/4,000	400/4,000	55
MKX	16-16	35	SQ3	2	75234	0	GP,TA,SV,JR		675/4,500	675/4,500	45
MKZ	07-09	39	SQ1	1-1/4	24775		GP,JR,TA	3592	200/2,000		45
MKZ	10-12	25	SQ1	1-1/4	24865	0	GP,JR	3594	200/2,000		20
MKZ	13-17	19	SQ1	1-1/4	24897	0	HM,SV	3594	200/2,000		20
Navigator	98-02	42	SQ3	2	75071	0	GP		500/5,000	800/8,000	15
		41	SQ4	2	41527	0	GP		600/6,000	1,000/10,000	15
Navigator w/Factory 7-Way	98-11										
Navigator	03-03										
Town Car	81-02	36	SQ1	1-1/4	24526		CA,GP,HA	3592	200/2,000		25
Town Car	81-11	39	SQ2	1-1/4	36116		CA,GP,HA	36063	300/3,500		30
Town Car	90-11	38	SQ3	2	41116		AB,CA,EO,GP,HA		350/3,500	750/6,000	30
Zephyr	06-06	39	SQ1	1-1/4	24775		GP,JR,TA	3592	200/2,000		45
MAZDA											
2	11-14	28	SQ1	1-1/4	24869	0	GP,JR	3593	200/2,000		30
3 4 Dr. Sedan, Except w/Grand Touring LED Taillights	04-09	27	SQ1	1-1/4	24816		GP	3592	200/2,000		35
3 5 Dr. Hatchback, Except w/Grand Touring LED Taillights	04-09	27	SQ1	1-1/4	24816		GP	3592	200/2,000		35
3 4 Dr. Sedan, w/Grand Touring LED Taillights	06-09	27	SQ1	1-1/4	24816		GP	3592	200/2,000		35
3 5 Dr. Hatchback, w/Grand Touring LED Taillights	06-09	27	SQ1	1-1/4	24816		GP	3592	200/2,000		35
3 4 Dr. Sedan, Except w/Grand Touring LED Taillights	10-13	25	SQ1	1-1/4	24842	0	GP	3594	200/2,000		20
3 4 Dr. Sedan, w/Grand Touring LED Taillights	10-13	25	SQ1	1-1/4	24842	0	GP	3594	200/2,000		20
3 5 Dr. Hatchback, Except w/Grand Touring LED Taillights	10-13	20	SQ1	1-1/4	24843	0	GP	3594	200/2,000		15
3 5 Dr. Hatchback, w/Grand Touring LED Taillights	10-13	20	SQ1	1-1/4	24843	0	GP	3594	200/2,000		15
3 4 Dr. Sedan	14-15	25	RT1	1-1/4	24912	0	HM,JR	3593	200/2,000		15
3 5 Dr. Hatchback	14-17	25	SQ1	1-1/4	24914	0	HM,JR	3593	200/2,000		30
5	06-10	20	SQ1	1-1/4	24773		GP	3593	200/2,000		25
5	12-16	24	SQ1	1-1/4	24874		GP	3592	200/2,000		25
6 4 Dr. Sedan	03-08	39	SQ1	1-1/4	24775		GP,JR,TA	3594	200/2,000		45
6 5 Dr. Hatchback	04-08	39	SQ1	1-1/4	24775		GP,JR,TA	3594	200/2,000		45
6 Sport Wagon	04-07	16	SQ1	1-1/4	24785	0	TA,GP	3593	200/2,000		25
6 4 Dr. Sedan	09-13	25	SQ1	1-1/4	24832		GP,JR	3592	200/2,000		30
6 4 Dr. Sedan	14-17	25	SQ1	1-1/4	24908	0	HM	3594	200/2,000		30
B2300	94-97	24	SQ3	2	75082		EG,SD		400/4,000	750/6,000	20
		50	SQ3	2	37136	0			500/5,000	600/6,000	40
B2300	02-09	24	SQ3	2	75082		SD,V		400/4,000	750/6,000	20
		50	SQ3	2	37136	0			500/5,000	600/6,000	40
B2500	98-01	24	SQ3	2	75082		SD,V		400/4,000	750/6,000	20
		50	SQ3	2	37136	0			500/5,000	600/6,000	40
B3000	94-97	24	SQ3	2	75082		EG,SD		400/4,000	750/6,000	20
		50	SQ3	2	37136	0			500/5,000	600/6,000	40
B3000	98-01	24	SQ3	2	75082		SD,V		400/4,000	750/6,000	20
		50	SQ3	2	37136	0			500/5,000	600/6,000	40
B3000	02-08	24	SQ3	2	75082		SD,V		400/4,000	750/6,000	20
		50	SQ3	2	37136	0			500/5,000	600/6,000	40
B4000	94-97	24	SQ3	2	75082		EG,SD		400/4,000	750/6,000	20
		50	SQ3	2	37136	0			500/5,000	600/6,000	40

- | | |
|--|--|
| <p>AB Requires four (4) 3/8" spacer blocks (#01077011) for installation. (Sold separately)</p> <p>CA Models with dual exhaust require exhaust modification.</p> <p>EG Relocation of spare tire bracket is not required. NOTE: 19mm open end style wrench must be purchased to allow removal of spare tire after hitch installation.</p> <p>EO Requires longer ball mount.</p> <p>GP Hitch crosstube concealed behind bumper.</p> <p>HA External dress panel beneath 95-97 and 03-05 vehicles must be removed for hitch installation.</p> <p>HM Hitch crosstube is visible beneath bumper.</p> | <p>JR Exhaust must be temporarily lowered for installation.</p> <p>KH Minor heat shield modification may be required.</p> <p>SD Hitches produced before 07/21/06 are rated at 350/3500 WC.</p> <p>SV Trimming or removal of under body appearance panel may be required.</p> <p>TA Trunk access required for hitch installation.</p> <p>V For vehicles with factory installed step bumpers only.</p> |
|--|--|

RECEIVER HITCH APPLICATION GUIDE

T-ONE						TOW HARNESS						4-FLAT WIRING				REQ. 4 FLAT WIRING			BRAKE CONTROL HARNESS	IN	
PC	T-ONE	FN	IN	AMP	CP	PC	TOW HARN	FN	IN	AMP	CP	TYPE	ELEC	POS	CHOICE 1	CHOICE 2	6-WAY ADAPTER	7-WAY ADAPTER			7-WAY HARDWIRE
LINCOLN (Continued)																					
							20119 118015	RD	10	10		Both 7-Way	A	SUV6	119180	20252					
E18	118507	CH	45	2,1,5,6	X								A,E	SUV3,4	119148	119180	20320	20321	20224	3036-P	20
													A,E	SUV3,4	119148	119180	20320	20321	20224	3036-P	20
E17	118551	CH	45	4,2,7,5	X								N	SUV1,2		119251	20320	20321			
E23	118519	CH	45	4,2,7,5	X								N	SUV1,2		119251	20320	20321			
E18	118682	CH	45	4,2,7,5	X								A,E	SUV1,2	119148	119180					
E17	118502	CH	45	2,1,5,6	X								B,E	PC3,4	119148	119180					
E21	118543	CH,TR	45	2,1,5,6	X								B,E	PC3,4	119148	119180					
E17	118591	CH	45	2,1,5,6	X								A,E	PC1,2	119148	119180					
E5	118344	BN	10	7.5									A	SUV1,2	119180	20252	20320	20321	20224	3035-P	5
							20119 118015	RD	10	10		Both 7-Way	A	SUV6	119180	20252					
						E5	118344	BN	10	7.5		4-Flat	A	SUV1,2	119180	20252					
													A,E	PC3,4	119148	119180	20320	20321	20224		
													A,E	PC3,4	119148	119180	20320	20321	20224		
													A,E	PC3,4	119148	119180	20320	20321	20224		
E17	118502	CH	45	2,1,5,6	X								B,E	PC3,4	119148	119180					
MAZDA																					
E17	118520	CH	45	2,1,5,6	X								B,E	PC3,4	119148	119180					
E14	118420	CG	15	2,1,5	X								B	PC3,4	119130	119178					
E14	118420	CG	15	2,1,5	X								B	PC3,4	119130	119178					
													B,E	PC3,4	119148	119180					
													B,E	PC3,4	119148	119180					
E14	118420	CG	15	2,1,5	X								B	PC3,4	119130	119178					
													B,E	PC3,4	119148	119180					
E14	118420	CG	15	2,1,5	X								B	PC3,4	119130	119178					
													B,E	PC3,4	119148	119180					
E16	118405	CH	45	2,1,5,6	X								B,E	PC3,4	119148	119180					
E16	118405	CH	45	2,1,5,6	X								B,E	PC3,4	119148	119180					
E17	118520	CH	45	2,1,5,6	X								B,E	PC3,4	119148	119180		20321			
E17	118520	CH	45	2,1,5,6	X								B,E	PC3,4	119148	119180		20321			
E16	118405	CH	45	2,1,5,6	X								B,E	PC3,4	119148	119180					
E16	118405	CH	45	2,1,5,6	X								B,E	PC3,4	119148	119180					
													B,E	PC3,4	119148	119180					
E19	118483	CH	45	2,1,5,6	X								B,E	PC3,4	119148	119180					
E17	118587	CH	45	2,1,5,6	X								B,E	PC3,4	119148	119180					
E9	118325	BN,HG	5	2,1,5									B	PU3	119130	119178	20320	20321	20224		
E9	118325	BN,HG	5	2,1,5									B	PU3	119130	119178	20320	20321	20224		
E9	118325	BN,HG	5	2,1,5		E2	118241	BN,RD	5	7.5		4-Flat	B	PU3	119130	119178	20320	20321	20224		
E9	118325	BN,HG	5	2,1,5									B	PU3	119130	119178	20320	20321	20224		
E9	118325	BN,HG	5	2,1,5		E2	118241	BN,RD	5	7.5		4-Flat	B	PU3	119130	119178	20320	20321	20224		
E9	118325	BN,HG	5	2,1,5									B	PU3	119130	119178	20320	20321	20224		
E9	118325	BN,HG	5	2,1,5									B	PU3	119130	119178	20320	20321	20224		

- A** 2 wire system.
- B** 3 wire system. Converter required.
- BN** Exterior mounted plug on some or all models. May require an aftermarket electrical mounting box or bracket. (Sold separately)
- CG** T-One incorporates circuit protected taillight converter.
- CH** T-One is equipped with circuit protected ModuLite® module.
- E** ModuLite® required.
- HG** T-One incorporates taillight converter.
- N** DO NOT cut or splice vehicle wiring. Only use approved T-One or see auto dealer for trailer tow wiring kit.
- RD** For vehicles equipped with factory tow package may require additional components or may be used as a replacement harness.
- TR** Trimming or Modification of the vehicle connector may be required.

- RT1** Round Tube Class I 1-1/4"
- RT3** Round Tube Class III 2"
- SQ1** Square Tube Class I
- SQ2** Square Tube Class II
- SQ3** Square Tube Class III
- SQ4** Square Tube Class IV

RECEIVER HITCH APPLICATION GUIDE

MODEL / STYLE	YEAR	TRAILER HITCHES									
		PC	REC TYPE	REC SIZE	PART #	NO DRILL	FOOTNOTES	OPTIONAL DRAWBAR	WC (LBS.)	WD (LBS.)	IN
MAZDA (Continued)											
B4000	98-01	24	SQ3	2	75082		SD,V		400/4,000	750/6,000	20
		50	SQ3	2	37136	0			500/5,000	600/6,000	40
B4000	02-09	24	SQ3	2	75082		SD,V		400/4,000	750/6,000	20
		50	SQ3	2	37136	0			500/5,000	600/6,000	40
CX-3	16-17	35	SQ1	1-1/4	24933	0	JR,GP	3593	200/2,000		25
CX-5	13-15	35	SQ3	2	75748†	0	GP,JR		525/3,500		40
CX-5	13-16	23	SQ2	1-1/4	36602	0	GP,JR		300/3,500		30
		24	SQ3	2	75217	0	GP		525/3,500		30
CX-7	07-12	34	SQ2	1-1/4	36419	0	GP,JR	36061	300/3,500		40
		29	SQ3	2	75512	0	GP,JR		350/3,500		40
CX-9	07-15	37	RT3	2	75531	0	HM		400/4,000	400/4,000	15
CX-9	16-16	24	SQ2	1-1/4	36772	0	SV,JR,GP	36071	300/3,500		30
		24	SQ3	2	76020	0	SV,JR,GP		675/4,500	675/4,500	30
MPV Except w/Ground Effects	00-03	45	SQ2	1-1/4	36299†	0	†JR,HM	36071	300/3,500		15
		46	SQ3	2	75108	0			350/3,500	500/5,000	15
MPV w/Ground Effects	00-03	52	RT3	2	75507	0	HM,JR		350/3,500	500/5,000	20
MPV	04-06	52	RT3	2	75507	0	HM,JR		350/3,500	500/5,000	20
Protege	99-03	25	SQ1	1-1/4	24675	0	HM	3593	200/2,000		20
Protege5	02-03	36	SQ1	1-1/4	24714	0	JR,GP	3593	200/2,000		15
Tribute	01-03	38	RT3	2	75118	0	HM,KH		350/3,500	500/5,000	35
		50	SQ3	2	37136		KH		500/5,000	600/6,000	60
Tribute	04-04	38	RT3	2	75118	0	HM		350/3,500	500/5,000	35
		50	SQ3	2	37136				500/5,000	600/6,000	60
Tribute	05-06	22	SQ2	1-1/4	36501		HM	36051	300/3,500		20
		34	RT3	2	75751	0	HM		675/4,500	675/5,250	25
Tribute	08-11	22	SQ2	1-1/4	36501		HM	36051	300/3,500		20
		34	RT3	2	75751	0	HM		675/4,500	675/5,250	25
MERCEDES-BENZ											
C300 Sedan	15-17	27	SQ1	1-1/4	24953	0	DU,GP,SV	3593	200/2,000		75
GLA250	15-17	36	SQ3	2	75223	0	GP,JR,TA,KH		350/3,500		90
GLC300	16-16	27	SQ3	2	76082	0	JR,GP,KH,TA,AA,DU		675/4,500		65
GLE350 Except w/Active Curve System	16-17	52	SQ3	2	76024	0	GP,JR,SV		700/7,000	700/7,000	40
GLK350	10-12	56	RT3	2	75774	0	HM		600/4,000		20
GLK350	13-15	56	RT3	2	75774	0	HM		600/4,000		20
Metris	16-16	32	RT3	2	76015	0	HM		750/5,000	750/6,000	20
ML320	98-02	34	SQ3	2	75087	0			500/5,000	500/5,000	30
ML320 CDI Except w/Adaptive Variable Suspension	07-08	50	SQ3	2	75376		MB,TA		350/3,500	400/4,000	50
ML350	03-05	34	SQ3	2	75087	0			500/5,000	500/5,000	30
ML350 Except w/Adaptive Variable Suspension	06-09	50	SQ3	2	75376		MB,TA		350/3,500	400/4,000	50
ML350 Except BlueTEC or w/Adaptive Variable Suspension	10-11	50	SQ3	2	75376		MB,TA		350/3,500	400/4,000	50
ML350 Except BlueTEC & w/Active Curve System	12-15	54	SQ3	2	75874†	0	GP,JR,KA,MB		525/3,500	525/4,000	30
ML350 Except w/Active Curve System	12-15	52	SQ3	2	76024	0	GP,JR,SV		700/7,000	700/7,000	40
ML430	99-01	34	SQ3	2	75087	0			500/5,000	500/5,000	30
ML450 Hybrid, Except w/Adaptive Variable Suspension	10-11	50	SQ3	2	75376		MB,TA		350/3,500	400/4,000	50
ML500	02-05	34	SQ3	2	75087	0			500/5,000	500/5,000	30
ML500 Except w/Adaptive Variable Suspension	06-07	50	SQ3	2	75376		MB,TA		350/3,500	400/4,000	50
ML550 Except w/Adaptive Variable Suspension	08-11	50	SQ3	2	75376		MB,TA		350/3,500	400/4,000	50
R320 BlueTEC	09-09	43	SQ3	2	75470	0	SC		350/3,500		25
R320 BlueTEC w/Panoramic Roof Package	09-09	43	SQ3	2	75470		SC		350/3,500		50
R320 CDI	07-08	43	SQ3	2	75470	0	SC		350/3,500		25
R320 CDI w/Panoramic Roof Package	07-08	43	SQ3	2	75470		SC		350/3,500		50
R350	06-12	43	SQ3	2	75470	0	SC		350/3,500		25
R350 w/Panoramic Roof Package	06-12	43	SQ3	2	75470		SC		350/3,500		50

† Available while supply lasts.

AA Requires temporary removal of bumper during installation.

DU Fascia removal required.

GP Hitch cross-tube concealed behind bumper.

HM Hitch cross-tube is visible beneath bumper.

JR Exhaust must be temporarily lowered for installation.

KA Gasoline engine models only.

KH Minor heat shield modification may be required.

MB Will not fit models equipped with air suspension package.

SC Minor trimming of plastic trunk pan required.

SD Hitches produced before 07/21/06 are rated at 350/3500 WC.

SV Trimming or removal of under body appearance panel may be required.

TA Trunk access required for hitch installation.

V For vehicles with factory installed step bumpers only.

RECEIVER HITCH APPLICATION GUIDE

T-ONE						TOW HARNESS						4-FLAT WIRING				REQ. 4 FLAT WIRING		7-WAY HARDWIRE	BRAKE CONTROL HARNESS	IN
PC	T-ONE	FN	IN	AMP	CP	PC	TOW HARN	FN	IN	AMP	CP	TYPE	ELEC	POS	CHOICE 1	CHOICE 2	6-WAY ADAPTER			
MAZDA (Continued)																				
E9	118325	BN,HG	5	2.1,5		E2	118241	BN,RD	5	7.5		4-Flat	B	PU3	119130	119178	20320	20321	20224	
E9	118325	BN,HG	5	2.1,5									B	PU3	119130	119178	20320	20321	20224	
E14	118718	CH	45	5,7.5	X								B,E	SUV3,4	119148	119180				
E19	118563	CH	45	4.2,7.5	X								B,E	SUV3,4	119148	119180	20320	20321	20224	
E19	118563	CH	45	4.2,7.5	X								B,E	SUV3,4	119148	119180				
E16	118405	CH	45	2.1,5,6	X	E12	118249	RD	5	2.1,4.2	X	4-Flat	B,E	SUV3,4	119148	119180	20320	20321	20224	
E17	118520	CH	45	2.1,5,6	X								B,E	SUV3,4	119148	119180	20320	20321	20224	
													B,E	SUV3,4	119148	119180				
													B	SUV1,2	119130	119178	20320	20321	20224	
													B	SUV1,2	119130	119178	20320	20321	20224	
													B	SUV1,2	119130	119178	20320	20321	20224	
													B	PC3,4	119130	119178				
													B	PC1,2	119130	119178				
E9	118343	HG,RW	10	2.1,5									B	SUV1,2	119130	119178	20320	20321	20224	
													B,E	SUV1,2	119148	119180	20320	20321	20224	
E17	118426	BN,CH	45	2.1,4.2	X								B,E	SUV1,2	119148	119180	20320	20321	20224	
E17	118551	CH	45	4.2,7.5	X	E1	118251	BN,QP,RD	5	7.5		4-Flat	A	SUV1,2	119180	20252	20320	20321	20224	
MERCEDES-BENZ																				
													A,E	PC3,4						
													B,E	SUV1,2	119148	119180				
													B,E	SUV1,2	119148	119180				
													B,E	SUV3,4	119148	119180	20320	20321	20224	
													BT	SUV3,4	119251	119191	20320	20321	20224	
													BM	SUV3,4	119251	119191	20320	20321	20224	
													BT	SUV1,2	119251	119191				
													E	SUV3	119180	119148	20320	20321	20224	
													BM	SUV3,4	119251	119191	20320	20321		
													E	SUV3	119180	119148	20320	20321	20224	
													BM	SUV3,4	119251	119191	20320	20321		
													BM	SUV3,4	119251	119191	20320	20321	20224	
													B,E	SUV3,4	119148	119180	20320	20321	20224	
													B,E	SUV3,4	119148	119180	20320	20321	20224	
													E	SUV3	119180	119148	20320	20321	20224	
													BM	SUV3,4	119251	119191	20320	20321	20224	
													E	SUV3	119180	119148	20320	20321	20224	
													BT	SUV3,4	119251	119191	20320	20321		
													BM	SUV3,4	119251	119191	20320	20321		
													BM	SUV3,4	119251	119191	20320	20321		
													BM	SUV3,4	119251	119191	20320	20321		
													BM	SUV3,4	119251	119191	20320	20321		
													BM	SUV3,4	119251	119191	20320	20321		
													BT	SUV3,4	119251	119191	20320	20321		
													BT	SUV3,4	119251	119191	20320	20321		

- A** 2 wire system.
- B** 3 wire system. Converter required.
- BM** Multiplexed wiring system. ModuLite® HD Plus or Ultra required.
- BN** Exterior mounted plug on some or all models. May require an aftermarket electrical mounting box or bracket. (Sold separately)
- BT** Shared Brake/Tail multiplexed wiring system. ModuLite® HD Plus or Ultra required.
- BT** Shared Brake/Tail/Turn multiplexed wiring system. ModuLite® HD Plus or Ultra required.
- CH** T-One is equipped with circuit protected ModuLite® module.
- E** ModuLite® required.
- HG** T-One incorporates taillight converter.
- QP** Will not fit vehicles with backup sensors built into rear bumper.
- RD** For vehicles equipped with factory tow package may require additional components or may be used as a replacement harness.
- RW** On some models it may require an upgraded flasher or ModuLite®.

- RT3** Round Tube Class III 2"
- SQ1** Square Tube Class I
- SQ2** Square Tube Class II
- SQ3** Square Tube Class III

RECEIVER HITCH APPLICATION GUIDE

MODEL / STYLE	YEAR	TRAILER HITCHES										
		PC	REC TYPE	REC SIZE	PART #	NO DRILL	FOOTNOTES	OPTIONAL DRAWBAR	WC (LBS.)	WD (LBS.)	IN	
MERCEDES-BENZ (Continued)												
R500	06-07	43	SQ3	2	75470	0	SC		350/3,500		25	
R500 w/Panoramic Roof Package	06-07	43	SQ3	2	75470	0	SC		350/3,500		50	
Sprinter 144" & 170" Wheelbase, Except w/Factory Step Bumper	07-09	53	SQ4	2	75549	0	HM,UL		600/6,000	750/7,500	20	
Sprinter w/Factory Step Bumper Excluding Models w/30-3/8" Frame Width	07-09	52	SQ3	2	75601	0	HM		500/5,000	750/7,500	30	
Sprinter 2500 144" & 170" Wheelbase, Except w/Factory Step Bumper	10-13	53	SQ4	2	75549	0	HM,UL		600/6,000	750/7,500	20	
Sprinter 2500 w/Factory Step Bumper Excluding Models w/30-3/8" Frame Width	10-13	52	SQ3	2	75601	0	HM		500/5,000	750/7,500	30	
Sprinter 2500 144" & 170" Wheelbase, Except w/Factory Step Bumper	14-16	53	SQ4	2	75549	0	HM,UL		600/6,000	750/7,500	20	
Sprinter 2500 w/Factory Step Bumper Excluding Models w/30-3/8" Frame Width	14-16	52	SQ3	2	75601	0	HM		500/5,000	750/7,500	30	
Sprinter 3500 144" & 170" Wheelbase, Except w/Factory Step Bumper	10-13	53	SQ4	2	75549	0	HM,UL		600/6,000	750/7,500	20	
Sprinter 3500 w/Factory Step Bumper Excluding Models w/30-3/8" Frame Width	10-13	52	SQ3	2	75601	0	HM		500/5,000	750/7,500	30	
Sprinter 3500 144" & 170" Wheelbase, Except w/Factory Step Bumper	14-16	53	SQ4	2	75549	0	HM,UL		600/6,000	750/7,500	20	
Sprinter 3500 w/Factory Step Bumper Excluding Models w/30-3/8" Frame Width	14-16	52	SQ3	2	75601	0	HM		500/5,000	750/7,500	30	
MERCURY												
Cougar	96-97	41	SQ2	1-1/4	36179	0	GP		36063	300/3,500	40	
Grand Marquis	92-97	36	SQ1	1-1/4	24526		CA,GP		3592	200/2,000	25	
		39	SQ2	1-1/4	36116		CA,GP		36063	300/3,500	30	
		38	SQ3	2	41116		CA,GP			350/3,500	750/6,000	30
Grand Marquis	98-11	36	SQ1	1-1/4	24526		CA,GP		3592	200/2,000	25	
		39	SQ2	1-1/4	36116		CA,GP		36063	300/3,500	30	
		38	SQ3	2	41116		CA,GP			350/3,500	750/6,000	30
Marauder	03-04	36	SQ1	1-1/4	24526		CA,GP		3592	200/2,000	25	
		39	SQ2	1-1/4	36116		CA,GP		36063	300/3,500	30	
		38	SQ3	2	41116		CA,GP			350/3,500	750/6,000	30
Mariner	05-07	22	SQ2	1-1/4	36501		HM		36051	300/3,500	20	
		34	RT3	2	75751	0	HM			675/4,500	675/5,250	25
Mariner	08-11	22	SQ2	1-1/4	36501		HM		36051	300/3,500	20	
		34	RT3	2	75751	0	HM			675/4,500	675/5,250	25
Milan	06-09	39	SQ1	1-1/4	24775		GP,JP,TA		3592	200/2,000	45	
Milan	10-11	25	SQ1	1-1/4	24865	0	GP,JP		3594	200/2,000	20	
Montego	05-07	33	SQ2	1-1/4	36360	0	GP,JP		36071	300/3,500	30	
		42	SQ3	2	75299	0	JP			350/3,500	400/4,000	30
Monterey	04-07	41	SQ2	1-1/4	36318	0	GP,JP		36071	300/3,500	25	
		45	SQ3	2	75158		GP,JP			350/3,500	500/5,000	30
Mountaineer	97-01	32	SQ2	1-1/4	36246	0	HM		36051	300/3,500	15	
		34	RT3	2	75083	0	JF,HM			500/5,000	600/6,000	15
		31	SQ3	2	75096	0	HM			500/5,000	750/7,500	15
Mountaineer w/Factory 7-Way	00-10											
Mountaineer	02-03	51	RT3	2	75132	0	HM,KL			500/5,000	800/8,000	20
Mountaineer	04-05	51	RT3	2	75132	0	HM,KL			500/5,000	800/8,000	20
Mountaineer w/1-1/4" Receivers	06-07	39	RT3	2	75437	0	HM,KL			500/5,000	800/8,000	25
Mountaineer w/1-1/4" Receivers	08-10	39	RT3	2	75437	0	HM,KL			500/5,000	800/8,000	25
Sable Sedan	96-99	35	SQ1	1-1/4	24699	0	GP,JP		3593	200/2,000	20	
		35	SQ2	1-1/4	36252	0	GP,JP		36063	300/3,500	20	

CA Models with dual exhaust require exhaust modification.
 GP Hitch crosstube concealed behind bumper.
 HM Hitch crosstube is visible beneath bumper.
 JF Will not fit with 16" spare tire.
 JR Exhaust must be temporarily lowered for installation.

KL Hitch is designed to attach beneath the OEM hitch.
 SC Minor trimming of plastic trunk pan required.
 TA Trunk access required for hitch installation.
 UL This hitch will not fit a Sprinter single or dual rear-wheel vehicle with a 30-3/8" wide frame measured outside of frame to outside of frame.

RECEIVER HITCH APPLICATION GUIDE

T-ONE						TOW HARNESS						4-FLAT WIRING				REQ. 4 FLAT WIRING		7-WAY HARDWIRE	BRAKE CONTROL HARNESS	IN
PC	T-ONE	FN	IN	AMP	CP	PC	TOW HARN	FN	IN	AMP	CP	TYPE	ELEC	POS	CHOICE 1	CHOICE 2	6-WAY ADAPTER			
MERCEDES-BENZ (Continued)																				
													BT	SUV3,4	119251	119191	20320	20321		
													BT	SUV3,4	119251	119191	20320	20321		
E17	118650	CH	45	5,7.5	X								B,E	SUV1,2	119148	119180	20320	20321	20224	
E17	118650	CH	45	5,7.5	X								B,E	SUV1,2	119148	119180	20320	20321	20224	
E17	118650	CH	45	5,7.5	X								B,E	SUV3,4	119192	119191	20320	20321	20224	
E17	118650	CH	45	5,7.5	X								B,E	SUV3,4	119192	119191	20320	20321	20224	
E19	118649	CH	45	5,7.5	X								BT	SUV3,4	119251	119191	20320	20321	20224	
E19	118649	CH	45	5,7.5	X								BT	SUV3,4	119251	119191	20320	20321	20224	
E17	118650	CH	45	5,7.5	X								B,E	SUV3,4	119192	119191	20320	20321	20224	
E17	118650	CH	45	5,7.5	X								B,E	SUV3,4	119192	119191	20320	20321	20224	
	188649	CH											BT	SUV3,4	119251	119191	20320	20321	20224	
E19	118649	CH	45	5,7.5	X								BT	SUV3,4	119251	119191	20320	20321	20224	
MERCURY																				
E9	118326		20	7.5									A,E	PC3,4	119148	119180	20320	20321	20224	
													A,E	PC3,4	119148	119180	20320	20321	20224	
													A,E	PC3,4	119148	119180	20320	20321	20224	
E17	118551	CH	45	4,2,7.5	X								A,E	SUV1,2	119148	119180	20320	20321	20224	
E17	118551	CH	45	4,2,7.5	X	E1	118251	BN,QP,RD	5	7.5		4-Flat	A	SUV1,2	119180	20252	20320	20321	20224	
E17	118502	CH	45	2,1.5,6	X								B,E	PC3,4	119148	119180				
E17	118502	CH	45	2,1.5,6	X								B,E	PC3,4	119148	119180				
													B,E	PC3,4	119148	119180	20320	20321	20224	
E17	118385	CH	45	2,1.5,6	X								N	SUV1,2		119251	20320	20321		
E16	118345	BN,CH	45	2,1,4,2		E2	118241	BN,RD	5	7.5		4-Flat	B,E	SUV1,2	119148	119180	20320	20321	20224	
							20119 118015	RD RD	10 10			Both 7-Way	A	SUV6	119180	20252				
E5	118344	BN	10	7.5									A	SUV1,2	119180	20252	20320	20321	20224	3035-P 5
													A	SUV1,2	119180	20252	20320	20321	20224	3035-P 5
													A	SUV1,2	119180	20252	20320	20321	20224	3035-P 5
													B	SUV1,2	119130	119178	20320	20321	20224	3035-P 5
E9	118333	HG	10	2,1.5									B	PC3,4	119130	119178				

- A** 2 wire system.
- B** 3 wire system. Converter required.
- BN** Exterior mounted plug on some or all models. May require an aftermarket electrical mounting box or bracket. (Sold separately)
- BT** Shared Brake/Tail multiplexed wiring system. ModuLite® HD Plus or Ultra required.
- CH** T-One is equipped with circuit protected ModuLite® module.
- E** ModuLite® required.
- HG** T-One incorporates taillight converter.
- N** DO NOT cut or splice vehicle wiring. Only use approved T-One or see auto dealer for trailer tow wiring kit.
- QP** Will not fit vehicles with backup sensors built into rear bumper.
- RD** For vehicles equipped with factory tow package may require additional components or may be used as a replacement harness.

- RT3** Round Tube Class III 2"
- SQ1** Square Tube Class I
- SQ2** Square Tube Class II
- SQ3** Square Tube Class III
- SQ4** Square Tube Class IV

RECEIVER HITCH APPLICATION GUIDE

MODEL / STYLE	YEAR	TRAILER HITCHES									
		PC	REC TYPE	REC SIZE	PART #	NO DRILL	FOOTNOTES	OPTIONAL DRAWBAR	WC (LBS.)	WD (LBS.)	IN
MERCURY (Continued)											
Sable Wagon	96-99	35	SQ1	1-1/4	24699	0	GP, JR	3593	200/2,000		20
		35	SQ2	1-1/4	36252	0	GP, JR	36063	300/3,500		20
Sable Sedan	00-03	35	SQ1	1-1/4	24699	0	GP, JR	3592	200/2,000		20
		35	SQ2	1-1/4	36252	0	GP, JR	36063	300/3,500		20
		47	SQ2	1-1/4	36313	0	GP, JR	36061	300/3,500		40
Sable Wagon	00-03	35	SQ1	1-1/4	24699	0	GP, JR	3592	200/2,000		20
		35	SQ2	1-1/4	36252	0	GP, JR	36063	300/3,500		20
		47	SQ2	1-1/4	36313	0	GP, JR	36061	300/3,500		40
Sable Sedan	04-05	47	SQ2	1-1/4	36313	0	GP, JR	36061	300/3,500		40
Sable Wagon	04-05	47	SQ2	1-1/4	36313	0	GP, JR	36061	300/3,500		40
Sable Sedan	08-09	33	SQ2	1-1/4	36360	0	GP, JR	36071	300/3,500		30
		42	SQ3	2	75299	0	JR		350/3,500	400/4,000	30
Villager	93-97	41	SQ2	1-1/4	36261	0	JR, GP	36061	300/3,500		15
		47	SQ3	2	75089	0	JR		350/3,500	500/5,000	15
Villager	98-98	41	SQ2	1-1/4	36261	0	JR, GP	36061	300/3,500		15
		47	SQ3	2	75089	0	JR		350/3,500	500/5,000	15
Villager	99-02	39	SQ2	1-1/4	36277	0	JR, GP	36061	300/3,500		15
		44	SQ3	2	75102	0	JR		350/3,500	500/5,000	15
MINI											
Cooper Countryman Except John Cooper Works Model	11-16	37	SQ1	1-1/4	24934	0	DU, GP, X	3593	200/2,000		70
MINI											
Eclipse	06-12	24	SQ1	1-1/4	24754		TA, GP	3592	200/2,000		30
Endeavor	04-05	41	RT3	2	75163	0	JR		350/3,500	500/5,000	20
Endeavor	06-08	41	SQ3	2	75519	0	JR		350/3,500		25
Endeavor	10-11										
Galant	07-12	19	SQ1	1-1/4	24835	0	JR, KH, HM	3593	200/2,000		30
Lancer 4 Dr. Sedan, Except Evolution, Ralliart & w/Dual Exhaust	08-11	27	SQ1	1-1/4	24885	0	GP, JR	3593	200/2,000		25
Lancer 5 Dr. Hatchback, Except Ralliart & w/Dual Exhaust	10-14	27	SQ1	1-1/4	24885	0	GP, JR	3593	200/2,000		25
Lancer 4 Dr. Sedan, Except Evolution, Ralliart & w/Dual Exhaust	12-16	27	SQ1	1-1/4	24885	0	GP, JR	3593	200/2,000		25
Lancer 4 Dr. Sedan, Except Evolution, Ralliart & w/Dual Exhaust	17-17										
Mirage	14-15	27	SQ1	1-1/4	24916	0	HM, JR	3593	200/2,000		20
Mirage Except Mirage G4	17-17	27	SQ1	1-1/4	24916	0	HM, JR	3593	200/2,000		20
Montero Except Montero Sport	01-06	50	SQ3	2	75116	0	KH		500/5,000	550/5,500	20
Montero Sport	97-04	40	SQ3	2	75075	0	GP		500/5,000	550/5,500	20
Outlander	03-06	30	SQ1	1-1/4	24732	0	KH, GP	3591	200/2,000		40
Outlander	07-10	44	SQ3	2	75555	0	HM, JR		400/4,000	400/4,000	25
Outlander Except Outlander Sport	11-13	44	SQ3	2	75555	0	HM, JR		400/4,000	400/4,000	25
Outlander Except Outlander Sport	14-17	36	RT3	2	75888	0	HM, JR		600/4,000	600/4,000	30
Outlander Sport	11-16	25	RT2	1-1/4	36509	0	HM	36051	300/3,500		30
		25	RT3	2	76098	0			675/4,500		20
Raider	06-09	27	SQ3	2	75251	0	HM		500/5,000	800/8,000	20
Raider w/Factory 7-Way	06-09										
RVR (Canada Only)	11-12	25	RT2	1-1/4	36509	0	HM	36051	300/3,500		30
		25	RT3	2	76098	0			675/4,500		30
RVR (Canada Only)	13-14	25	RT2	1-1/4	36509	0	HM	36051	300/3,500		30
RVR (Canada Only)	13-16	25	RT3	2	76098	0			675/4,500		30
NISSAN											
Altima	93-97	39	SQ1	1-1/4	24690	0	HM, JR	3593	200/2,000		20
Altima	98-01	39	SQ1	1-1/4	24690	0	HM, JR	3593	200/2,000		20
Altima	02-06	31	SQ1	1-1/4	24788	0	JR, TA, GP	3592	200/2,000		30

DU Fascia removal required.
 GP Hitch crosstube concealed behind bumper.
 HM Hitch crosstube is visible beneath bumper.
 JR Exhaust must be temporarily lowered for installation.

KH Minor heat shield modification may be required.
 TA Trunk access required for hitch installation.
 X Minor fascia trimming required.

RECEIVER HITCH APPLICATION GUIDE

N

NISSAN

T-ONE						TOW HARNESS						4-FLAT WIRING				REQ. 4 FLAT WIRING		7-WAY HARDWIRE	BRAKE CONTROL HARNESS	IN
PC	T-ONE	FN	IN	AMP	CP	PC	TOW HARN	FN	IN	AMP	CP	TYPE	ELEC	POS	CHOICE 1	CHOICE 2	6-WAY ADAPTER			
MERCURY (Continued)																				
													B	PC3,4	119130	119178				
E4	118375		10	7.5									A	PC3,4	119180	20252				
													A	PC3,4	119180	20252				
													B	PC3,4	119130	119178				
													A	PC3,4	119180	20252				
E7	118447		10	7.5									A	PC3,4	119180	20252	20320	20321	20224	
													B	SUV1,2	119130	119178	20320	20321	20224	
E10	118362	BN,HG	5	2.1,5									B	SUV1,2	119130	119178	20320	20321	20224	
													B	SUV1,2	119130	119178	20320	20321	20224	
MINI																				
													B,E	SUV3,4	119148	119180				
MITSUBISHI																				
													E	PC3,4	119180	119148				
E12	118516		30	2.1,5,6	X								B,E	SUV1,2	119148	119180	20320	20321	20224	
E12	118516		30	2.1,5,6	X								B,E	SUV1,2	119148	119180	20320	20321	20224	
E12	118516	CH	30	2.1,5,6	X								B,E	SUV3	119148	119180				
E14	118420	CG	15	2.1,5	X								B	PC3,4	119130	119178				
													B,E	PC3,4	119148	119180				
E16	118538		45	2.1,5,6	X								B,E	PC1,2	119148	119180				
E16	118538		45	2.1,5,6	X								B,E	PC3,4	119148	119180				
E16	118538		45	2.1,5,6	X								B,E	PC3,4	119148	119180				
													B,E	PC3,4	119148	119180				
													B,E	PC3,4	119148	119180				
E12	118380	BN,HG	20	2.1,5									B	SUV1,2	119130	119178	20320	20321	20224	
													B	SUV1,2	119130	119178	20320	20321	20224	
E8	118306		25	2.1,5									B,E	SUV3,4	119148	119180				
E18	118518	CH	45	4,2,7,5	X								B,E	SUV3,4	119148	119180	20320	20321	20224	
E18	118518	CH	45	4,2,7,5	X								B,E	SUV3,4	119148	119180	20320	20321	20224	
E17	118482	CH	45	2.1,5,6	X								B,E	SUV3,4	119148	119180	20320	20321	20224	
E16	118538	CH	45	2.1,5,6	X								B,E	SUV1,2	119148	119180				
E6	118323	BN,HJ	10	7.5		E3	118381	BN,RD	5	7.5		4-Flat	A	PU1,2	119180	20252	20320	20321	20224	
							20135	RD	10			Both	A	PU3	119180	20252				
E16	118538	CH	45	2.1,5,6	X								B,E	SUV1,2	119148	119180	20320	20321		
E16	118538	CH	45	2.1,5,6	X								B,E	SUV1,2	119148	119180	20320	20321		
													B,E	SUV1,2	119148	119180	20320	20321		
NISSAN																				
													B	PC3,4	119130	119178				
E8	118361	HG	20	2.1,5									B	PC3,4	119130	119178				
													B,E	PC3,4	119148	119180				

- A** 2 wire system.
- B** 3 wire system. Converter required.
- BN** Exterior mounted plug on some or all models. May require an aftermarket electrical mounting box or bracket. (Sold separately)
- CG** T-One incorporates circuit protected taillight converter.
- CH** T-One is equipped with circuit protected ModuLite® module.

- E** ModuLite® required.
- HG** T-One incorporates taillight converter.
- HJ** Per Dodge owner's manual: If trailer is equipped with more than standard lighting (1 taillight per side) use of ModuLite® or dealer supplied harness is required.
- RD** For vehicles equipped with factory tow package may require additional components or may be used as a replacement harness.

- RT2** Round Tube Class II 1-1/4"
- RT3** Round Tube Class III 2"
- SQ1** Square Tube Class I
- SQ2** Square Tube Class II
- SQ3** Square Tube Class III

RECEIVER HITCHES

RECEIVER HITCH APPLICATION GUIDE

MODEL / STYLE	YEAR	TRAILER HITCHES									
		PC	REC TYPE	REC SIZE	PART #	NO DRILL	FOOTNOTES	OPTIONAL DRAWBAR	WC (LBS.)	WD (LBS.)	IN
NISSAN (Continued)											
Altima Sedan	07-15	15	SQ1	1-1/4	24796		AE, HM, TA	3594	200/2,000		45
Altima Coupe, Except SR Models	08-13	28	SQ1	1-1/4	24801	0	HM	3594	200/2,000		30
Altima Sedan	16-16	15	SQ1	1-1/4	24796		AE, HM, TA	3594	200/2,000		45
Armada	05-07	38	RT4	2	75741	0	HM		600/6,000	1,000/10,000	15
Armada w/Factory 7-Way	05-14										
Armada	08-14	35	RT4	2	75644	0	HM		600/6,000	1,000/10,000	15
Cube	09-13	20	SQ1	1-1/4	24845		HM, JR	3593	200/2,000		45
Frontier	98-04	41	SQ3	2	75186		GP		400/4,000	550/5,500	30
		50	SQ3	2	37136				500/5,000	600/6,000	35
Frontier	05-16										
		20	SQ3	2	75282	0	GP, TE		750/5,000	800/8,000	30
Frontier w/Factory Tow Package	05-16										
JUKE AWD, Except Nismo & Nismo RS	11-16	27	SQ1	1-1/4	24867	0	HM, JR	3593	200/2,000		40
JUKE FWD, Except Nismo & Nismo RS	11-16	30	SQ1	1-1/4	24892		HM, JR	3593	200/2,000		25
Leaf	11-14										
Maxima Sedan	95-99	34	SQ1	1-1/4	24686		TA, GP	3593	200/2,000		30
Maxima Sedan	00-02	34	SQ1	1-1/4	24686		TA, GP	3592	200/2,000		30
Maxima Sedan	03-03	34	SQ1	1-1/4	24686		TA, GP	3592	200/2,000		30
Maxima	04-08	31	SQ1	1-1/4	24788	0	JR, TA, GP	3592	200/2,000		30
Maxima	09-14	15	SQ1	1-1/4	24796		AE, HM, TA	3594	200/2,000		45
Maxima	16-17	15	SQ1	1-1/4	24796		AE, HM, TA	3594	200/2,000		45
Murano	03-07	37	SQ3	2	75148	0	JR		350/3,500		30
Murano Except w/Aero Kit & CrossCabriolet	09-14	30	SQ3	2	75647	0	GP, JR		400/4,000		35
Murano	15-16	28	RT3	2	75952	0	HM		600/4,000	600/4,000	15
NP300 Navara	16-16	38	SQ3	2	76078	0	HM		800/8,000	800/8,000	30
NV1500	12-16	28	SQ4	2	75715	0	HM		1,125/7,500	1,000/10,000	20
NV200	13-16	31	RT3	2	75898	0	HM, JR, X		525/3,500		30
NV2500	12-16	28	SQ4	2	75715	0	HM		1,125/7,500	1,000/10,000	20
NV3500	12-16	28	SQ4	2	75715	0	HM		1,125/7,500	1,000/10,000	20
Pathfinder	96-04	39	SQ2	1-1/4	36222	0	HM	36071	300/3,500		20
		34	RT3	2	75077	0			500/5,000	550/5,500	20
Pathfinder	05-12										
Pathfinder	13-16	21	SQ3	2	76031	0	HM		900/6,000	900/6,000	25
Pathfinder	17-17	21	SQ3	2	76031	0	HM		900/6,000	900/6,000	25
Pathfinder Armada	04-04	38	RT4	2	75741	0	HM		600/6,000	1,000/10,000	15
Pathfinder Armada w/Factory 7-Way	04-04										
Pickup	95-97	41	SQ3	2	75186		GP		400/4,000	550/5,500	30
		50	SQ3	2	37136				500/5,000	600/6,000	30
Quest	93-97	41	SQ2	1-1/4	36261	0	JR, GP	36061	300/3,500		15
		47	SQ3	2	75089	0	JR		350/3,500	500/5,000	15
Quest	98-98	41	SQ2	1-1/4	36261	0	JR, GP	36061	300/3,500		15
		47	SQ3	2	75089	0	JR		350/3,500	500/5,000	15
Quest	99-02	39	SQ2	1-1/4	36277	0	JR, GP	36061	300/3,500		15
		44	SQ3	2	75102	0	JR		350/3,500	500/5,000	15
Quest	04-09	50	SQ3	2	75159	0	JR		350/3,500	500/5,000	20
Quest	11-16	51	RT3	2	75714	0	HM, JR		525/3,500		35
Rogue Except Krom	08-13	18	SQ2	1-1/4	36542	0	GP	36053	300/3,500		15
		25	SQ3	2	75902	0	GP		350/3,500		15
Rogue	14-16	18	SQ2	1-1/4	36542	0	GP	36053	300/3,500		15
		25	SQ3	2	75902	0	GP		350/3,500		15

AE Requires temporary removal of muffler during installation.
 GP Hitch crosstube concealed behind bumper.
 HM Hitch crosstube is visible beneath bumper.
 JR Exhaust must be temporarily lowered for installation.

TA Trunk access required for hitch installation.
 TE Hitches produced before 04/20/11 are rated at 500/5000 WC.
 X Minor fascia trimming required.

RECEIVER HITCH APPLICATION GUIDE

N

NISSAN

T-ONE						TOW HARNESS						4-FLAT WIRING				REQ. 4 FLAT WIRING		BRAKE CONTROL HARNESS	IN		
PC	T-ONE	FN	IN	AMP	CP	PC	TOW HARN	FN	IN	AMP	CP	TYPE	ELEC	POS	CHOICE 1	CHOICE 2	6-WAY ADAPTER			7-WAY ADAPTER	7-WAY HARDWIRE
NISSAN (Continued)																					
E17	118470	CH	45	2.1,5.6	X								B,E	PC3,4	119148	119180					
E17	118470	CH	45	2.1,5.6	X								B	PC3,4	119130	119178					
E15	118731	CH	45	5,7.5	X								B,E	PC3,4	119148	119180					
						E8	118384	BN,RD	5	7.5		4-Flat	A	SUV6	119180	20252	20320	20321	20224	3050-P	5
							20119	RD	10			Both	H	SUV6	119180	20252					
							118015	RD	10			7-Way									
						E8	118384	BN,RD	5	7.5		4-Flat	A	SUV6	119180	20252	20320	20321	20224	3050-P	5
E15	118492	CG	45	2.1,7.5	X								B	SUV1,2	119130	119178	20320	20321			
E10	118362	BN,HG	5	2.1,5									B	PU4	119130	119178	20320	20321	20224		
						E21	118266	BN,RD	30			7-Way	H	PU3	119180	20252				3050-P	5
						E9	118267	BN,RD,Z	30			7-Way	B,E	PU3	119148	119180				3050-P	5
E17	118528	CH	45	2.1,5.6	X								B,E	SUV3,4	119148	119180	20320	20321			
E17	118528	CH	45	2.1,5.6	X								B,E	SUV3,4	119148	119180	20320	20321			
E16	118625	CH	45	2.1,5.6	X								B,E	PC3,4	119148	119180					
													B	PC3,4	119130	119178					
													B	PC3,4	119130	119178					
													B,E	PC3,4	119148	119180					
E17	118470	CH	45	2.1,5.6	X								B,E	PC3,4	119148	119180					
E17	118470	CH	45	2.1,5.6	X								B,E	PC3,4	119148	119180					
E15	118676	CH	45	4,2,7.5	X								B,E	PC3,4	119148	119180					
													D				20320	20321			
E15	118653	CH	45	4,2,7.5	X								B,E	SUV3,4	119148	119180	20320	20321	20224		
E15	118660	CH	45	4,2,7.5	X								B,E	SUV3,4	119148	119180	20320	20321	20224		
E17	118553	CH	45	4,2,7.5	X								B,E	SUV3,4	119148	119180	20320	20321	20224		
E17	118597	CH	45	4,2,7.5	X								B,E	SUV3,4	119148	119180	20320	20321	20224		
E17	118553	CH	45	4,2,7.5	X								B,E	SUV3,4	119148	119180	20320	20321	20224		
E17	118553	CH	45	4,2,7.5	X								B,E	SUV3,4	119148	119180	20320	20321	20224		
E8	118361	HG	20	2.1,5									B	SUV1,2	119130	119178	20320	20321	20224		
E14	118525	BN	30	7.5		E21	118266	BN,RD	30			7-Way	H	SUV5	119180	20252				3050-P	5
						E9	118267	BN,RD	30			7-Way									
E20	118670	BN	30	7.5		E23	118273	BN,RD	20	10		7-Way	B,E	SUV1,2	119148	119180					
						E8	118384	BN,RD	5	7.5		4-Flat	A	SUV6	119180	20252	20320	20321	20224	3050-P	5
							118015	RD	10			7-Way	H	SUV6	119180	20252					
E8	118353	BN,HG	10	2.1,5									B	PU1,2	119130	119178	20320	20321	20224		
													B	SUV1,2	119130	119178	20320	20321	20224		
E10	118362	BN,HG	5	2.1,5									B	SUV1,2	119130	119178	20320	20321	20224		
													B	SUV1,2	119130	119178	20320	20321	20224		
E16	118469	CH	45	2.1,5.6	X								B,E	SUV1,2	119148	119180	20320	20321	20224		
E19	118547	BN,CH	45	4,2,7.5	X								B,E	SUV1,2	119148	119180	20320	20321	20224		
E15	118480	CH	45	2.1,5.6	X								B,E	SUV3,4	119148	119180	20320	20321	20224		
E15	118480	CH	45	2.1,5.6	X								B,E	SUV3,4	119148	119180	20320	20321	20224		

- A** 2 wire system.
- B** 3 wire system. Converter required.
- BN** Exterior mounted plug on some or all models. May require an aftermarket electrical mounting box or bracket. (Sold separately)
- CG** T-One incorporates circuit protected taillight converter.
- CH** T-One is equipped with circuit protected ModuLite® module.
- D** See auto dealer for trailer tow wiring kit.

- E** ModuLite® required.
- H** 3 wire system with OEM standard 2 wire harness.
- HG** T-One incorporates taillight converter.
- RD** For vehicles equipped with factory tow package may require additional components or may be used as a replacement harness.
- Z** May be equipped with Factory Tow Prep Plug. Determine at time of installation.

- RT3** Round Tube Class III 2"
- RT4** Round Tube Class IV 2"
- SQ1** Square Tube Class I
- SQ2** Square Tube Class II
- SQ3** Square Tube Class III
- SQ4** Square Tube Class IV

RECEIVER HITCHES

RECEIVER HITCH APPLICATION GUIDE

MODEL / STYLE	YEAR	TRAILER HITCHES									
		PC	REC TYPE	REC SIZE	PART #	NO DRILL	FOOTNOTES	OPTIONAL DRAWBAR	WC (LBS.)	WD (LBS.)	IN
NISSAN (Continued)											
Rogue Select	14-14	18	SQ2	1-1/4	36542	0	GP	36053	300/3,500		15
		25	SQ3	2	75902	0	GP		350/3,500		15
Sentra	00-02	31	SQ1	1-1/4	24750	0	TA, HM	3593	200/2,000		20
Sentra	03-06	31	SQ1	1-1/4	24750	0	TA, HM	3593	200/2,000		20
Sentra	07-12	22	SQ1	1-1/4	24794		TA, GP	3594	200/2,000		30
Sentra Except SR	13-16	28	SQ1	1-1/4	24907		HM	3593	200/2,000		35
Titan	04-15	38	RT4	2	41551	0			600/6,000	1,000/10,000	15
Titan w/Factory 7-Way	04-15										
Versa 4 Dr. Sedan	07-11	35	SQ1	1-1/4	24798		HM	3593	200/2,000		25
Versa 5 Dr. Hatchback	07-12	35	SQ1	1-1/4	24798		HM	3593	200/2,000		25
Versa 4 Dr. Sedan	12-17	29	SQ1	1-1/4	24887		HM, JR, KH	3592	200/2,000		30
Versa Note	14-16	16	SQ1	1-1/4	24909		HM, JR, KH	3592	200/2,000		30
Xterra	00-04	41	RT3	2	75107	0			350/3,500	550/5,500	15
Xterra	05-15										
		37	RT3	2	75291	0			350/3,500	550/5,500	30
Xterra w/Factory Tow Package	05-15										
X-Trail (Canada Only)	05-06	35	SQ1	1-1/4	24740	0	EP, GP	3593	200/2,000		45
OLDSMOBILE											
88	96-99	50	SQ2	1-1/4	36211		GP, KH	36061	300/3,500		30
Alero	99-04	42	SQ2	1-1/4	36288		GP	36071	300/3,500		20
Aurora	01-03	39	SQ2	1-1/4	36309		HM, JR	36063	300/3,500		30
Bravada	96-97	32	SQ2	1-1/4	36244	0	GP	36051	300/3,500		15
		21	RT3	2	75079	0	SD		400/4,000	600/6,000	15
Bravada	98-01	32	SQ2	1-1/4	36244	0	FP, GP, KK	36051	300/3,500		15
		21	RT3	2	75079	0	FP, KK, SD		400/4,000	600/6,000	15
Bravada w/Factory 7-Way	99-04										
Bravada w/Factory 7-Way	02-04										
Cutlass 4 Dr., FWD	97-99	34	SQ1	1-1/4	24656	0	GP	3592	200/2,000		15
		41	SQ2	1-1/4	36233		GP	36061	300/3,500		20
Cutlass Supreme 4 Dr. FWD	92-97	45	SQ2	1-1/4	36124		AI, JR, TA, HM	36053	300/3,500		60
Intrigue	98-02	24	SQ1	1-1/4	24659		TA, GP	3592	200/2,000		30
		37	SQ2	1-1/4	36374		GP, JR	36061	300/3,500		30
LSS	96-99	50	SQ2	1-1/4	36211		GP, KH	36061	300/3,500		30
Regency	97-98	50	SQ2	1-1/4	36211		GP, KH	36061	300/3,500		30
Silhouette	97-04	27	SQ1	1-1/4	24721		AL, GP, JR	3592	200/2,000		30
		27	SQ2	1-1/4	36361		AL, GP, JR	36061	300/3,500		40
		22	SQ3	2	75278		AL, GP, JR		350/3,500	500/5,000	40
PLYMOUTH											
Breeze	96-00	40	SQ2	1-1/4	36301		JR, HM	36061	300/3,500		60
Grand Voyager	96-00	25	SQ1	1-1/4	24702	0	HM	3593	200/2,000		30
		23	SQ2	1-1/4	36296	0	GP	36071	300/3,500		30
		30	RT3	2	75119				350/3,500	500/5,000	30
		50	SQ3	2	37136				500/5,000	600/6,000	40
Neon	00-01	42	SQ1	1-1/4	24701		GP, JR	3593	200/2,000		20
Voyager	96-00	25	SQ1	1-1/4	24702	0	HM	3593	200/2,000		30
		23	SQ2	1-1/4	36296	0	GP	36071	300/3,500		30
		30	RT3	2	75119				350/3,500	500/5,000	30
		50	SQ3	2	37136				500/5,000	600/6,000	40

- | | |
|---|--|
| <p>AI Additional installation time may be required.</p> <p>AL Additional installation time required for vehicles equipped with load leveling compressor.</p> <p>EP Fascia trimming may be required.</p> <p>FP Spare tire repositioning and/or modification of spare tire carrier may be required.</p> <p>GP Hitch crosstube concealed behind bumper.</p> <p>HM Hitch crosstube is visible beneath bumper.</p> | <p>JR Exhaust must be temporarily lowered for installation.</p> <p>KH Minor heat shield modification may be required.</p> <p>KK When installing on a vehicle originally equipped with an OEM hitch, OEM bumper brackets must be purchased and installed prior to new hitch installation.</p> <p>SD Hitches produced before 07/21/06 are rated at 350/3500 WC.</p> <p>TA Trunk access required for hitch installation.</p> |
|---|--|

RECEIVER HITCH APPLICATION GUIDE

T-ONE						TOW HARNESS						4-FLAT WIRING				REQ. 4 FLAT WIRING		7-WAY HARDWIRE	BRAKE CONTROL HARNESS	IN	
PC	T-ONE	FN	IN	AMP	CP	PC	TOW HARN	FN	IN	AMP	CP	TYPE	ELEC	POS	CHOICE 1	CHOICE 2	6-WAY ADAPTER				7-WAY ADAPTER
NISSAN (Continued)																					
E15	118480	CH	45	2.1,5.6	X								B,E	SUV3,4	119148	119180	20320	20321	20224		
													B	PC3,4	119130	119178					
													B,E	PC3,4	119148	119180					
E17	118470	CH	45	2.1,5.6	X								B,E	PC3,4	119148	119180					
E16	118582	CH	45	2.1,5.6	X								B,E	PC3,4	119148	119180					
						E8	118384	BN,RD	5	7.5		4-Flat	A	PU3	119180	20252	20320	20321	20224	3050-P	5
							20119	RD	10			Both	H	PU3	119180	20252					
							118015	RD	10			7-Way									
													B,E	PC3,4	119148	119180					
E17	118545	CH	45	2.1,5.6	X								B,E	PC3,4	119148	119180					
													B,E	PC3,4	119148	119180					
E16	118582	CH	45	2.1,5.6	X								B,E	PC3,4	119148	119180					
						E1	118244	BN,RD	5	7.5		4-Flat	B	SUV7	119130	119178	20320	20321	20224		
						E21	118266	BN,RD	30			7-Way	H	SUV5	119180	20252					
						E9	118267	BN,RD,Z	30			7-Way	B,E	SUV5	119148	119180					
													B	SUV1,2	119130	119178					
OLDSMOBILE																					
													A	PC3,4	119180	20252					
													B	PC3,4	119130	119178					
													B,E	PC3,4	119148	119180					
													A	SUV7	119180	20252	20320	20321	20224		
						E8	118384	BN,RD	5	7.5		4-Flat	A	SUV7	119180	20252	20320	20321	20224		
E8	118384	BN,RD	5	7.5			20119	RD	10		Both	A	SUV6	119180	20252						
							118015	RD	10		7-Way										
							20047	RD	5		7-Way										
						E8	118384	BN,RD	5	7.5		4-Flat	H	SUV6	119180	20252					
													B	PC3,4	119130	119178					
													A	PC3,4	119180	20252					
													B	PC3,4	119130	119178					
													A	PC3,4	119180	20252					
													A	PC3,4	119180	20252					
E8	118355	HG	10	2.1,5									B	SUV3	119130	119178	20320	20321	20224		
PLYMOUTH																					
													B	PC3,4	119130	119178					
E10	118334	HG	20	2.1,5									B	SUV1,2	119130	119178	20320	20321	20224		
													A	PC3,4	119180	20252					
E10	118334	HG	20	2.1,5									B	SUV1,2	119130	119178	20320	20321	20224		

A 2 wire system.
B 3 wire system. Converter required.
BN Exterior mounted plug on some or all models. May require an aftermarket electrical mounting box or bracket. (Sold separately)
CH T-One is equipped with circuit protected ModuLite® module.
E ModuLite® required.

H 3 wire system with OEM standard 2 wire harness.
HG T-One incorporates taillight converter.
RD For vehicles equipped with factory tow package may require additional components or may be used as a replacement harness.
Z May be equipped with Factory Tow Prep Plug. Determine at time of installation.

RT3 Round Tube Class III 2"
RT4 Round Tube Class IV 2"
SQ1 Square Tube Class I
SQ2 Square Tube Class II
SQ3 Square Tube Class III

RECEIVER HITCH APPLICATION GUIDE

MODEL / STYLE	YEAR	TRAILER HITCHES									
		PC	REC TYPE	REC SIZE	PART #	NO DRILL	FOOTNOTES	OPTIONAL DRAWBAR	WC (LBS.)	WD (LBS.)	IN
PONTIAC											
Aztek	01-05	34	SQ2	1-1/4	36425		HM	36071	300/3,500		40
		33	SQ3	2	75138	0			350/3,500		55
		28	SQ3	2	75430		HM		350/3,500		40
Bonneville Except SLE/SSE/SSEi	96-99	50	SQ2	1-1/4	36211		GP,KH	36063	300/3,500		30
Bonneville	00-05	39	SQ2	1-1/4	36309		HM,JR	36063	300/3,500		30
G3 5 Dr.	09-09	20	SQ1	1-1/4	24741		GP	3593	200/2,000		30
G3 Wave 5 Dr. (Canada Only)	09-09	20	SQ1	1-1/4	24741		GP	3593	200/2,000		30
G5 Except GT	07-09	20	SQ1	1-1/4	24745		JR,HM	3593	200/2,000		40
G5 GT	07-09	30	SQ1	1-1/4	24756		HM,JR	3594	200/2,000		25
G6	05-09	36	SQ2	1-1/4	36426		GP	36065	300/3,500		30
G8	08-09	31	SQ1	1-1/4	24821	0	JR,KH,HM	3594	200/2,000		45
Grand Am	99-05	42	SQ2	1-1/4	36288		GP	36071	300/3,500		20
Grand Prix	97-08	27	SQ1	1-1/4	24660	0	TA,GP	3594	200/2,000		20
		51	SQ2	1-1/4	36241		JR,GP	36065	300/3,500		35
Grand Prix SE Sedan	97-03	24	SQ1	1-1/4	24659		TA,GP	3592	200/2,000		30
Montana	99-05	27	SQ1	1-1/4	24721		AL,GP,JR	3592	200/2,000		30
		27	SQ2	1-1/4	36361		AL,GP,JR	36061	300/3,500		40
		22	SQ3	2	75278		AL,GP,JR		350/3,500	500/5,000	40
Montana SV6	05-06	27	SQ2	1-1/4	36361		AL,GP,JR	36061	300/3,500		40
		22	SQ3	2	75278		AL,GP,JR		350/3,500	500/5,000	40
Montana SV6 (Canada Only)	07-09	27	SQ2	1-1/4	36361		AL,GP,JR	36061	300/3,500		40
		22	SQ3	2	75278		AL,GP,JR		350/3,500	500/5,000	40
Pursuit 2 Dr. (Canada Only)	05-06	20	SQ1	1-1/4	24745		JR,HM	3593	200/2,000		40
Pursuit 4 Dr. (Canada Only)	05-06	20	SQ1	1-1/4	24745		JR,HM	3593	200/2,000		40
Solstice	06-08	21	SQ1	1-1/4	24833	0	HM,JR	3594	200/2,000		35
Solstice GXP	07-08	21	SQ1	1-1/4	24833	0	HM,JR,X	3594	200/2,000		35
Solstice	09-09	21	SQ1	1-1/4	24833		HM,JR	3594	200/2,000		40
Solstice GXP	09-09	21	SQ1	1-1/4	24833		HM,JR,X	3594	200/2,000		40
Sunfire Except GT	95-99	31	SQ1	1-1/4	24733		GP,JR	3592	200/2,000		40
Sunfire	00-02	39	SQ1	1-1/4	24613		JR,KH,GP	3592	200/2,000		40
Sunfire	03-05	31	SQ1	1-1/4	24733		GP,JR	3592	200/2,000		40
Sunfire GT	95-99	39	SQ1	1-1/4	24613		JR,KH,GP	3592	200/2,000		40
Torrent	06-06	18	SQ2	1-1/4	36408	0	HM	36051	300/3,500		25
		15	RT3	2	76028		HM		675/4,500	675/4,500	30
Torrent	07-09	18	SQ2	1-1/4	36408	0	HM	36051	300/3,500		25
		15	RT3	2	76028	0	HM		675/4,500	675/4,500	30
Trans Sport	97-98	27	SQ1	1-1/4	24721		AL,GP,JR	3592	200/2,000		30
		27	SQ2	1-1/4	36361		AL,GP,JR	36061	300/3,500		40
		22	SQ3	2	75278		AL,GP,JR		350/3,500	500/5,000	40
Vibe	03-08	15	SQ1	1-1/4	24812	0	HM	3593	200/2,000		15
Vibe Except GT	09-10	15	SQ1	1-1/4	24812	0	HM	3593	200/2,000		15
Wave 5 Dr. (Canada Only)	05-07	20	SQ1	1-1/4	24741		GP	3593	200/2,000		30
Wave5 (Canada Only)	08-08	20	SQ1	1-1/4	24741		GP	3593	200/2,000		30
PORSCHE											
Cayenne	11-16	45	SQ4	2	75950	0	GP,EP,TA		750/7,500		70
Macan	15-17	37	SQ3	2	75940	0	DU,EP,GP,TA		750/5,000		60
RAM											
1500	11-12	39	RT4	2	75232	0	CP		1,000/10,000	1,200/12,000	40
		11	SQ4	2	75662		CP		600/6,000	1,000/10,000	20
		39	SQ5	2	41948	0	@,HM,CP		1,500/12,000	1,500/15,000	30
1500 w/Factory 7-Way	11-17										

@ Ultra Frame ball mount must be used to achieve maximum weight carrying rating.
 AL Additional installation time required for vehicles equipped with load leveling compressor.
 CP Fits all models without factory installed receiver.
 DU Fascia removal required.
 EP Fascia trimming may be required.
 GP Hitch crosstube concealed behind bumper.

HM Hitch crosstube is visible beneath bumper.
 JR Exhaust must be temporarily lowered for installation.
 KH Minor heat shield modification may be required.
 TA Trunk access required for hitch installation.
 X Minor fascia trimming required.

RECEIVER HITCH APPLICATION GUIDE

R

RAM

T-ONE						TOW HARNESS						4-FLAT WIRING				REQ. 4 FLAT WIRING			BRAKE CONTROL HARNESS	IN	
PC	T-ONE	FN	IN	AMP	CP	PC	TOW HARN	FN	IN	AMP	CP	TYPE	ELEC	POS	CHOICE 1	CHOICE 2	6-WAY ADAPTER	7-WAY ADAPTER			7-WAY HARDWIRE
PONTIAC																					
E10	118383	BN	20	7.5									A	SUV1,2	119180	20252	20320	20321	20224		
													E	PC3,4	119180	119148					
													B,E	PC3,4	119148	119180					
E13	118485	CG	15	2.1,7.5	X								B	PC3,4	119130	119178					
													B	PC3,4	119130	119178					
E5	118407	BN	15	7.5									A	PC1,2	119180	20252					
E5	118407	BN	15	7.5									A	PC1,2	119180	20252					
E7	118439	BN	15	7.5									A	PC3,4	119180	20252					
													B	PC3,4	119130	119178					
													B	PC3,4	119130	119178					
													A	PC3,4	119180	20252					
E8	118355	HG	10	2.1,5									B	SUV3	119130	119178	20320	20321	20224		
E10	118396	BN	15	7.5									A	SUV1,2	119180	20252	20320	20321	20224		
E10	118396	BN	15	7.5									A	SUV1,2	119180	20252	20320	20321	20224		
E5	118407	BN	15	7.5									A	PC1,2	119180	20252					
E8	118398	BN	10	7.5									A	PC1,2	119180	20252					
													A	PC1,2	119180	20252					
													A	PC1,2	119180	20252					
													A	PC1,2	119180	20252					
													A	PC1,2	119180	20252					
													A	PC1,2	119180	20252					
													A	PC3,4	119180	20252					
													A	PC3,4	119180	20252					
E8	118391	CG	10	2.1,5	X								B	SUV3	119130	119178	20320	20321	20224		
E7	118432	CE	10	7.5									B	SUV1,2	119130	119178	20320	20321	20224		
E8	118355	HG	10	2.1,5									B	SUV3	119130	119178	20320	20321	20224		
E11	118458	CG	15	2.1,5	X								B	SUV3,4	119130	119178					
E16	118460	CH	45	2.1,4.2	X								B,E	SUV3,4	119148	119180	20320	20321			
													B	PC3,4	119130	119178					
													B	PC3,4	119130	119178					
PORSCHE																					
													B,E	SUV1,2	119148	119180	20320	20321	20224		
													BT	SUV1,2	119251	119191	20320	20321	20224		
RAM																					
						E8	118384	BN,RD	5	7.5		4-Flat	A	PU3	119180	20252	20320	20321	20224	3021-P	5
E8	118384	BN,RD	5	7.5			20119 118015	RD RD	10 10			Both 7-Way	A	PU3	119180	20252					

- A** 2 wire system.
- B** 3 wire system. Converter required.
- BN** Exterior mounted plug on some or all models. May require an aftermarket electrical mounting box or bracket. (Sold separately)
- BT** Shared Brake/Tail multiplexed wiring system. ModuLite® HD Plus or Ultra required.
- CE** T-One includes fuse(s) & relay(s). Converter not required. Standard 2 wire system at factory tow plug.

- CG** T-One incorporates circuit protected taillight converter.
- CH** T-One is equipped with circuit protected ModuLite® module.
- E** ModuLite® required.
- HG** T-One incorporates taillight converter.
- RD** For vehicles equipped with factory tow package may require additional components or may be used as a replacement harness.

- RT3** Round Tube Class III 2"
- RT4** Round Tube Class IV 2"
- SQ1** Square Tube Class I
- SQ2** Square Tube Class II
- SQ3** Square Tube Class III
- SQ4** Square Tube Class IV
- SQ5** Square Tube Class V

RECEIVER HITCHES

RECEIVER HITCH APPLICATION GUIDE

MODEL / STYLE	YEAR	TRAILER HITCHES									
		PC	REC TYPE	REC SIZE	PART #	NO DRILL	FOOTNOTES	OPTIONAL DRAWBAR	WC (LBS.)	WD (LBS.)	IN
RAM (Continued)											
1500	13-14	39	RT4	2	75232	Ø	CP		1,000/10,000	1,200/12,000	40
		11	SQ4	2	75662		CP		600/6,000	1,000/10,000	20
		39	SQ5	2	41948	Ø	@,HM,CP		1,500/12,000	1,500/15,000	30
1500	15-17	39	RT4	2	75232	Ø	CP		1,000/10,000	1,200/12,000	40
		11	SQ4	2	75662		CP		600/6,000	1,000/10,000	20
		39	SQ5	2	41948	Ø	@,HM,CP		1,500/12,000	1,500/15,000	30
2500	11-12	37	SQ5	2	41929		@,GP,KL,SG		1,200/12,000	1,500/15,000	35
		66	SQ5	2-1/2	45509		#,AA,GH,HM,LT,SO,TO		2,000/18,000	2,500/18,000	95
2500 Except Mega Cab	11-12	64	SQ5	2-1/2	45518		#,KL,SB		1,200/12,000	1,700/14,000	35
2500 w/Factory 7-Way	11-17										
2500	13-14	37	SQ5	2	41929		@,GP,KL,SG		1,200/12,000	1,500/15,000	35
		66	SQ5	2-1/2	45509		#,AA,GH,HM,LT,SO,TO		2,000/18,000	2,500/18,000	95
2500 Except Mega Cab	13-14	64	SQ5	2-1/2	45518		#,KL,SB		1,200/12,000	1,700/14,000	35
2500	15-17	37	SQ5	2	41929		@,GP,KL,SG		1,200/12,000	1,500/15,000	35
		66	SQ5	2-1/2	45509		#,AA,GH,HM,LT,SO,TO		2,000/18,000	2,500/18,000	95
2500 Except Mega Cab	15-17	64	SQ5	2-1/2	45518		#,KL,SB		1,200/12,000	1,700/14,000	35
3500	11-12	37	SQ5	2	41929		@,GP,KL,SG		1,200/12,000	1,500/15,000	35
		66	SQ5	2-1/2	45509		#,AA,GH,HM,LT,SO,TO		2,000/18,000	2,500/18,000	95
3500 Cab & Chassis, w/34" Wide Frames	11-12	29	SQ5	2	41936		@		1,200/12,000		30
		50	SQ5	2	41947		@		1,600/15,000	1,600/16,000	35
3500 Except Mega Cab	11-12	64	SQ5	2-1/2	45518		#,KL,SB		1,200/12,000	1,700/14,000	35
3500 w/Factory 7-Way	11-17										
3500	13-14	37	SQ5	2	41929		@,GP,KL,SG		1,200/12,000	1,500/15,000	35
		66	SQ5	2-1/2	45509		#,AA,GH,HM,LT,SO,TO		2,000/18,000	2,500/18,000	95
3500 Except Mega Cab	13-14	64	SQ5	2-1/2	45518		#,KL,SB		1,200/12,000	1,700/14,000	35
3500	15-17	37	SQ5	2	41929		@,GP,KL,SG		1,200/12,000	1,500/15,000	35
		66	SQ5	2-1/2	45509		#,AA,GH,HM,LT,SO,TO		2,000/18,000	2,500/18,000	95
3500 Except Mega Cab	15-17	64	SQ5	2-1/2	45518		#,KL,SB		1,200/12,000	1,700/14,000	35
4500 Cab & Chassis, w/34" Wide Frames	11-12	29	SQ5	2	41936		@		1,200/12,000		30
		50	SQ5	2	41947		@		1,600/15,000	1,600/16,000	35
4500 Cab & Chassis, w/34" Wide Frames	13-16	38	SQ5	2	41952		@		1,500/15,000	1,600/16,000	45
5500 Cab & Chassis, w/34" Wide Frames	11-12	29	SQ5	2	41936		@		1,200/12,000		30
		50	SQ5	2	41947		@		1,600/15,000	1,600/16,000	35
5500 Cab & Chassis, w/34" Wide Frames	13-16	38	SQ5	2	41952		@		1,500/15,000	1,600/16,000	45
C/V Tradesman	12-15	24	SQ2	1-1/4	36455	Ø	GP,JR	36061	300/3,500		20
		21	SQ3	2	75579	Ø	GP,JR		400/4,000	500/5,000	20
Dakota	11-11	27	SQ3	2	75251		HM		500/5,000	800/8,000	20
ProMaster 1500 All Models	14-16	25	SQ3	2	76050	Ø	AA,DU,GP		500/5,000		45
ProMaster 1500 Except w/Extended Body	14-16	58	RT4	2	75882		HM		750/6,000	750/7,500	45
ProMaster 2500 All Models	14-16	25	SQ3	2	76050	Ø	AA,DU,GP		500/5,000		45
ProMaster 2500 Except w/Extended Body	14-16	58	RT4	2	75882		HM		750/6,000	750/7,500	45
ProMaster 3500 All Models	14-16	25	SQ3	2	76050	Ø	AA,DU,GP		500/5,000		45
ProMaster 3500 Except w/Extended Body	14-16	58	RT4	2	75882		HM		750/6,000	750/7,500	45
ProMaster City	15-17	37	SQ3	2	75219	Ø	GP		350/3,500		60
SAAB											
9-3	99-02	34	SQ2	1-1/4	36280		JR,GP	36053	300/3,500		30
9-3 Convertible	03-03	34	SQ2	1-1/4	36280		JR,GP	36053	300/3,500		30
9-5	99-05	41	SQ2	1-1/4	36286	Ø	TA,HM	36051	300/3,500		30

- # Titan hitches require use of a 2-1/2" shank Titan ball mount.
- @ Ultra Frame ball mount must be used to achieve maximum weight carrying rating.
- AA Requires temporary removal of bumper during installation.
- CP Fits all models without factory installed receiver.
- DU Fascia removal required.
- GH Will not fit models with 34" wide frames.
- GP Hitch crosstube concealed behind bumper.
- HM Hitch crosstube is visible beneath bumper.
- JR Exhaust must be temporarily lowered for installation.
- KL Hitch is designed to attach beneath the OEM hitch.
- LT Requires removal of factory hitch if equipped.
- SB Will not fit models with short bed.
- SG Hitches produced before 09/10/07 are rated at 1000/10000 WC & 1200/12000 WD.
- SO With this hitch installed the step bumper is no longer able to be used as a towing point.
- TA Trunk access required for hitch installation.
- TO Will not fit models equipped Chassis Cab spring mount.

RECEIVER HITCH APPLICATION GUIDE

T-ONE						TOW HARNESS						4-FLAT WIRING				REQ. 4 FLAT WIRING		BRAKE CONTROL HARNESS	IN		
PC	T-ONE	FN	IN	AMP	CP	PC	TOW HARN	FN	IN	AMP	CP	TYPE	ELEC	POS	CHOICE 1	CHOICE 2	6-WAY ADAPTER			7-WAY ADAPTER	7-WAY HARDWIRE
RAM (Continued)																					
						E8	118384	BN,RD	5	7.5		4-Flat	A	PU3	119180	20252	20320	20321	20224	3023-P	10
						E8	118384	BN,RD	5	7.5		4-Flat	A	PU3	119180	20252	20320	20321	20224	3024-P	5
						E8	118384	BN,RD	5	7.5		4-Flat	A	PU3	119180	20252	20320	20321	20224	3021-P	5
						E8	118384	BN,RD	5	7.5		4-Flat	A	PU3	119180	20252	20320	20321	20224	3021-P	5
E8	118384	BN,RD	5	7.5			20119	RD	10			Both	A	PU3	119180	20252					
							118015	RD	10			7-Way									
						E8	118384	BN,RD	5	7.5		4-Flat	A	PU3	119180	20252	20320	20321	20224	3023-P	10
						E8	118384	BN,RD	5	7.5		4-Flat	A	PU3	119180	20252	20320	20321	20224	3023-P	10
						E8	118384	BN,RD	5	7.5		4-Flat	A	PU3	119180	20252	20320	20321	20224	3024-P	5
						E8	118384	BN,RD	5	7.5		4-Flat	A	PU3	119180	20252	20320	20321	20224	3024-P	5
													C	PU1,2	119180	119148	20320	20321	20224		
						E8	118384	BN,RD	5	7.5		4-Flat	A	PU3	119180	20252	20320	20321	20224	3021-P	5
E8	118384	BN,RD	5	7.5			20119	RD	10			Both	A	PU3	119180	20252					
							118015	RD	10			7-Way									
						E8	118384	BN,RD	5	7.5		4-Flat	A	PU3	119180	20252	20320	20321	20224	3023-P	10
						E8	118384	BN,RD	5	7.5		4-Flat	A	PU3	119180	20252	20320	20321	20224	3023-P	10
						E8	118384	BN,RD	5	7.5		4-Flat	A	PU3	119180	20252	20320	20321	20224	3024-P	5
						E8	118384	BN,RD	5	7.5		4-Flat	A	PU3	119180	20252	20320	20321	20224	3024-P	5
													A	PU3	119180	119148	20320	20321	20224		
													A	PU3	119180	119148	20320	20321	20224		
													A	PU3	119180	119148	20320	20321	20224		
E18	118534	BN,CH	45	4.2,7.5	X								C,E	SUV1,2	119180	119148	20320	20321	20224		
E6	118323	BN,HJ	10	7.5									A	PU1,2	119180	20252	20320	20321	20224	3020-P	5
E18	118618	CH	45	4.2,7.5	X		22112	BN	60			7-Way	B,E	SUV3,4	119148	119180	20320	20321	20224		
E18	118618	CH	45	4.2,7.5	X		22112	BN	60			7-Way	B,E	SUV3,4	119148	119180	20320	20321	20224		
E18	118618	CH	45	4.2,7.5	X		22112	BN	60			7-Way	B,E	SUV3,4	119148	119180	20320	20321	20224		
E18	118618	CH	45	4.2,7.5	X		22112	BN	60			7-Way	B,E	SUV3,4	119148	119180	20320	20321	20224		
E18	118618	CH	45	4.2,7.5	X		22112	BN	60			7-Way	B,E	SUV3,4	119148	119180	20320	20321	20224		
E18	118719	CH,BN	45	4.2,7.5	X								BT	SUV1,2	119192	119191					
SAAB																					
													B,E	PC1,2	119148	119180					
													B,E	PC1,2	119148	119180					
													B,E	PC1,2	119148	119180					

- A** 2 wire system.
- B** 3 wire system. Converter required.
- BN** Exterior mounted plug on some or all models. May require an aftermarket electrical mounting box or bracket. (Sold separately)
- BT** Shared Brake/Tail multiplexed wiring system. ModuLite® HD Plus or Ultra required.
- C** 2 or 3 wire system determine at installation.
- CH** T-One is equipped with circuit protected ModuLite® module.
- E** ModuLite® required.
- HJ** Per Dodge owner's manual: If trailer is equipped with more than standard lighting (1 taillight per side) use of ModuLite® or dealer supplied harness is required.
- RD** For vehicles equipped with factory tow package may require additional components or may be used as a replacement harness.

- RT4** Round Tube Class IV 2"
- SQ2** Square Tube Class II
- SQ3** Square Tube Class III
- SQ4** Square Tube Class IV
- SQ5** Square Tube Class V

RECEIVER HITCH APPLICATION GUIDE

MODEL / STYLE	YEAR	TRAILER HITCHES									
		PC	REC TYPE	REC SIZE	PART #	NO DRILL	FOOTNOTES	OPTIONAL DRAWBAR	WC (LBS.)	WD (LBS.)	IN
SAAB (Continued)											
9-7X w/Factory 7-Way	05-09										
SATURN											
Astra Hatchback	08-09	34	SQ1	1-1/4	24809	0	GP, JR	3594	200/2,000		25
Aura	07-09	24	SQ2	1-1/4	36479		GP, JR, RB	36065	300/3,500		45
Ion Except Redline & w/2.4 Liter Engine	03-07	31	SQ1	1-1/4	24734		JR, GP	3593	200/2,000		35
Ion 3 w/2.4 Liter Engine	05-07	30	SQ1	1-1/4	24756		HM, JR	3594	200/2,000		25
Ion Red Line	04-06	30	SQ1	1-1/4	24756		HM, JR	3594	200/2,000		25
L100	01-02	14	SQ1	1-1/4	24685		TA, GP	3590	200/2,000		35
L200	01-02	14	SQ1	1-1/4	24685		TA, GP	3590	200/2,000		35
L300	01-02	14	SQ1	1-1/4	24685		TA, GP	3590	200/2,000		35
LS	00-00	14	SQ1	1-1/4	24685		TA, GP	3590	200/2,000		35
LS1	00-00	14	SQ1	1-1/4	24685		TA, GP	3590	200/2,000		35
LS2	00-00	14	SQ1	1-1/4	24685		TA, GP	3590	200/2,000		35
LW200 Wagon	03-03	14	SQ1	1-1/4	24685		TA, GP	3590	200/2,000		35
LW300 Wagon	03-03	14	SQ1	1-1/4	24685		TA, GP	3590	200/2,000		35
Outlook	07-09	19	RT3	2	75528	0	GP, JR, TN		750/5,000	750/7,500	25
Outlook w/Factory 7-Way	07-09										
Relay	05-07	27	SQ2	1-1/4	36361		AL, GP, JR	36061	300/3,500		40
		22	SQ3	2	75278		AL, GP, JR		350/3,500	500/5,000	40
SC1 2 Dr. Coupe	96-02	33	SQ1	1-1/4	24620		HM, JR, KH, TA	3592	200/2,000		40
SC2 2 Dr. Coupe	96-02	33	SQ1	1-1/4	24620		HM, JR, KH, TA	3592	200/2,000		40
Sky	07-09	21	SQ1	1-1/4	24833	0	HM, JR	3594	200/2,000		35
SL 4 Dr. Sedan	91-02	33	SQ1	1-1/4	24620		HM, JR, KH, TA	3592	200/2,000		40
SL1 4 Dr. Sedan	91-02	33	SQ1	1-1/4	24620		HM, JR, KH, TA	3592	200/2,000		40
SL2 4 Dr. Sedan	91-02	33	SQ1	1-1/4	24620		HM, JR, KH, TA	3592	200/2,000		40
SW1 Wagon	93-99	33	SQ1	1-1/4	24620		HM, JR, KH, TA	3592	200/2,000		40
SW2 Wagon	93-01	33	SQ1	1-1/4	24620		HM, JR, KH, TA	3592	200/2,000		40
Vue Except Redline	02-07	18	SQ2	1-1/4	36408	0	HM	36051	300/3,500		25
		15	RT3	2	76028	0	HM		675/4,500	675/4,500	30
Vue	08-09	25	SQ2	1-1/4	36450	0	GP	36061	300/3,500		15
		30	SQ3	2	75556	0	GP		400/4,000	400/4,000	15
SCION											
FR-S	13-13	30	SQ1	1-1/4	24935	0		3593	200/2,000		75
FR-S	14-14	30	SQ1	1-1/4	24935	0		3593	200/2,000		75
FR-S	15-16	30	SQ1	1-1/4	24935	0		3593	200/2,000		75
iA	16-16	32	RT1	1-1/4	24948	0	HM	3593	200/2,000		30
tC	05-06	11	SQ1	1-1/4	24827		GP	3593	200/2,000		30
tC	07-10	11	SQ1	1-1/4	24827		GP	3593	200/2,000		30
tC	11-13	13	SQ1	1-1/4	24815	0	GP	3593	200/2,000		15
tC	14-16	13	SQ1	1-1/4	24921	0	GP	3592	200/2,000		15
xB	04-06	22	SQ1	1-1/4	28501	0	JR, GP	28451	200/2,000		25
xB Except Release Series	08-10	13	SQ1	1-1/4	24815	0	GP	3593	200/2,000		15
xB Except Release Series	11-13	13	SQ1	1-1/4	24815	0	GP	3593	200/2,000		15
xD	08-10	14	SQ1	1-1/4	24828	0	GP, JR	3593	200/2,000		20
STERLING TRUCK											
Bullet 45 w/34" Wide Frames	08-09	29	SQ5	2	41936		@		1,200/12,000		30
		50	SQ5	2	41947		@		1,600/15,000	1,600/16,000	35

- @ Ultra Frame ball mount must be used to achieve maximum weight carrying rating.
- AL Additional installation time required for vehicles equipped with load leveling compressor.
- GP Hitch cross tube concealed behind bumper.
- HM Hitch cross tube is visible beneath bumper.
- JR Exhaust must be temporarily lowered for installation.
- KH Minor heat shield modification may be required.
- RB Hitch installation can be made easier with a "cutter" type drill bit.
- TA Trunk access required for hitch installation.
- TN Hitches produced before 07/09/12 are rated at 500/5000 WC & 500/5000 WD.

RECEIVER HITCH APPLICATION GUIDE

T-ONE						TOW HARNESS						4-FLAT WIRING				REQ. 4 FLAT WIRING		7-WAY HARDWIRE	BRAKE CONTROL HARNESS	IN
PC	T-ONE	FN	IN	AMP	CP	PC	TOW HARN	FN	IN	AMP	CP	TYPE	ELEC	POS	CHOICE 1	CHOICE 2	6-WAY ADAPTER			
SAAB (Continued)																				
						E8	118384 20119 20047 118015	BN,RD RD RD RD	5 10 5 10	7.5		4-Flat Both 7-Way 7-Way	H	SUV6	119180	20252				
SATURN																				
E11	118423	BN,HG	15	2.1,4,2									A,E	PC1,2	119148	119180				
													B,E	PC1,2	119148	119180				
													B	PC3,4	119130	119178				
													B	PC3,4	119130	119178				
													B	PC3,4	119130	119178				
													B	PC3,4	119130	119178				
													B	PC3,4	119130	119178				
													B	PC3,4	119130	119178				
													B	PC3,4	119130	119178				
													B	PC3,4	119130	119178				
													B	PC3,4	119130	119178				
													B	PC3,4	119130	119178				
													B	PC3,4	119130	119178				
													B	PC3,4	119130	119178				
E10	118434	BN	15	7.5		E8	118384 20119 20047 118015	BN,RD RD RD RD	5 10 5 10	7.5		4-Flat Both 7-Way 7-Way	N	SUV1,2 SUV6	119251	119251	20320	20321		3026-P 5
E10	118396	BN	15	7.5									A	SUV1,2	119180	20252	20320	20321	20224	
													B	PC3,4	119130	119178				
													B	PC3,4	119130	119178				
													A	PC1,2	119180	20252				
													B	PC3,4	119130	119178				
													B	PC3,4	119130	119178				
													B	PC3,4	119130	119178				
													B	PC3,4	119130	119178				
E16	118418	BN,CG	20	2.1,5	X								B	SUV1,2	119130	119178	20320	20321	20224	
E19	118443	CH	45	2.1,4,2	X								B,E	SUV3,4	119148	119180	20320	20321	20224	
SCION																				
E16	118629	CH	45	2.1,5,6	X								B,E	PC3,4	119148	119180				
													B,E	PC3,4	119148	119180				
E15	118728	CH,BN	45	5,7,5	X								B,E	PC1,2	119148	119180				
													B	PC1,2	119130	119178				
E13	118484	CG	15	2.1,5	X								B	PC1,2	119130	119178				
													B	PC1,2	119130	119178				
E18	118615	CH	45	2.1,5,6	X								B,E	PC3,4	119148	119180				
E12	118414	CG	20	2.1,5	X								B	SUV3,4	119130	119178				
E18	118468	CH	45	2.1,5,6	X								B,E	SUV3,4	119148	119180	20320	20321		
E16	118460	CH	45	2.1,4,2	X								B,E	SUV3,4	119148	119180	20320	20321		
													B	PC3,4	119130	119178				
STERLING TRUCK																				
													C	PU1,2	119180	119148	20320	20321	20224	

- | | | |
|---|---|--|
| <p>A 2 wire system.</p> <p>B 3 wire system. Converter required.</p> <p>BN Exterior mounted plug on some or all models. May require an aftermarket electrical mounting box or bracket. (Sold separately)</p> <p>C 2 or 3 wire system determine at installation.</p> <p>CG T-One incorporates circuit protected taillight converter.</p> <p>CH T-One is equipped with circuit protected ModuLite® module.</p> | <p>E ModuLite® required.</p> <p>H 3 wire system with OEM standard 2 wire harness.</p> <p>HG T-One incorporates taillight converter.</p> <p>N DO NOT cut or splice vehicle wiring. Only use approved T-One or see auto dealer for trailer tow wiring kit.</p> <p>RD For vehicles equipped with factory tow package may require additional components or may be used as a replacement harness.</p> | <p>RT1 Round Tube Class I 1-1/4"</p> <p>RT3 Round Tube Class III 2"</p> <p>SQ1 Square Tube Class I</p> <p>SQ2 Square Tube Class II</p> <p>SQ3 Square Tube Class III</p> <p>SQ5 Square Tube Class V</p> |
|---|---|--|

RECEIVER HITCH APPLICATION GUIDE

MODEL / STYLE	YEAR	TRAILER HITCHES									
		PC	REC TYPE	REC SIZE	PART #	NO DRILL	FOOTNOTES	OPTIONAL DRAWBAR	WC (LBS.)	WD (LBS.)	IN
STERLING TRUCK (Continued)											
Bullet 55 w/34" Wide Frames	08-09	29	SQ5	2	41936		@		1,200/12,000		30
		50	SQ5	2	41947		@		1,600/15,000	1,600/16,000	35
SUBARU											
B9 Tribeca	06-07	33	SQ3	2	75401	0	GP, JR		350/3,500	400/4,000	35
Baja	03-06	39	SQ1	1-1/4	24735	0	HM	3590	200/2,000		20
BRZ	13-16	30	SQ1	1-1/4	24935	0		3593	200/2,000		75
Crosstrek	15-16	24	RT3	2	76084	0	HM, JR, KH		525/3,500		20
Crosstrek Except Hybrid	15-16	24	RT3	2	76084	0	HM, JR, KH		525/3,500		20
Forester	98-08	20	SQ2	1-1/4	36311	0	GP, JR	36051	300/3,500		30
Forester	09-13	28	SQ1	1-1/4	24807		HM, JR	3594	200/2,000		35
		27	RT2	1-1/4	36521		HM, JR	36061	300/3,500		35
		27	SQ3	2	75650		HM, JR, TQ		600/4,000		35
Forester	14-17	21	SQ2	1-1/4	36523		HM, JR, KH	36053	300/3,500		30
		29	RT3	2	75876	0	HM, JR, KH		525/3,500	525/4,000	25
Impreza	93-01	25	SQ1	1-1/4	24710	0	JR, GP	3593	200/2,000		30
Impreza Except WRX STi	02-07	25	SQ1	1-1/4	24710	0	JR, GP	3593	200/2,000		30
Impreza 4 Dr. Sedan	08-11	28	SQ1	1-1/4	24807		HM, JR	3594	200/2,000		35
Impreza 5 Dr. Wagon, Except WRX STi & w/Quad Exhaust Outlets	08-11	19	SQ1	1-1/4	24886		HM, JR	3593	200/2,000		45
Impreza 4 Dr. Sedan, Except WRX & WRX STi	12-16	25	SQ1	1-1/4	24888		HM, JR	3594	200/2,000		30
Impreza 5 Dr. Wagon, Except WRX STi & w/Quad Exhaust Outlets	12-16	19	SQ1	1-1/4	24886		HM, JR	3593	200/2,000		45
Legacy Coupe & Sedan	90-99	48	SQ2	1-1/4	36234		KH, HM	36071	300/3,500		25
Legacy Wagon, Except Outback	96-99	48	SQ2	1-1/4	36234		KH, HM	36061	300/3,500		20
Legacy Wagon, Outback	96-99	48	SQ2	1-1/4	36234		KH, HM	36061	300/3,500		20
Legacy Sedan, Except Outback	00-04	46	SQ2	1-1/4	36284	0	HM	36061	300/3,500		20
Legacy Wagon, Except Outback	00-04	46	SQ2	1-1/4	36284	0	HM	36061	300/3,500		20
Legacy Sedan, Except Outback	05-07	35	SQ2	1-1/4	36334	0	JR, HM	36071	300/3,500		25
		44	SQ3	2	75560	0	JR		400/4,000		25
Legacy Wagon, Except Outback	05-07	35	SQ2	1-1/4	36334	0	JR, HM	36053	300/3,500		25
		44	SQ3	2	75560	0	JR		400/4,000		25
Legacy Sedan	08-09	35	SQ2	1-1/4	36334	0	JR, HM	36071	300/3,500		25
		44	SQ3	2	75560	0	JR		400/4,000		25
Legacy Sedan	10-14	25	SQ2	1-1/4	36493		HM, JR, KH	36071	300/3,500		45
		30	SQ3	2	75673		HM, JR, KH, TI		600/4,000		45
Legacy Sedan	15-17	25	SQ2	1-1/4	36493		HM, JR, KH	36071	300/3,500		45
		30	SQ3	2	75673		HM, JR, KH, TI		600/4,000		45
Outback Sedan, Except Sport	00-04	46	SQ2	1-1/4	36284	0	HM	36053	300/3,500		20
Outback Wagon, Except Sport	00-04	46	SQ2	1-1/4	36284	0	HM	36053	300/3,500		20
Outback Sedan, Except Sport	05-07	35	SQ2	1-1/4	36334	0	JR, HM	36071	300/3,500		25
		44	SQ3	2	75560	0	JR		400/4,000		25
Outback Wagon, Except Sport	05-09	35	SQ2	1-1/4	36334	0	JR, HM	36053	300/3,500		25
		44	SQ3	2	75560	0	JR		400/4,000		25
Outback Wagon, Except Sport	10-17	25	SQ2	1-1/4	36493		HM, JR, KH	36051	300/3,500		45
		30	SQ3	2	75673		HM, JR, KH, TI		600/4,000		45
Tribeca	08-10	33	SQ3	2	75401	0	GP, JR		350/3,500	400/4,000	35
Tribeca	11-14	36	SQ3	2	75716	0	GP		525/3,500	525/5,250	30
XV Crosstrek Except Hybrid	13-15	19	SQ1	1-1/4	24886		HM, JR	3593	200/2,000		45
		24	RT3	2	76084	0	HM, JR, KH, SY		525/3,500		20
XV Crosstrek Hybrid	13-15	19	SQ1	1-1/4	24886		HM, JR	3593	200/2,000		45
SUZUKI											
Equator	09-12										
		20	SQ3	2	75282	0	GP, TE		750/5,000	800/8,000	30
Equator w/Factory Tow Package	09-12										

- @ Ultra Frame ball mount must be used to achieve maximum weight carrying rating.
- GP Hitch crosstube concealed behind bumper.
- HM Hitch crosstube is visible beneath bumper.
- JR Exhaust must be temporarily lowered for installation.
- KH Minor heat shield modification may be required.

- SY Hitch crosstube is visible beneath bumper with a more than normal gap between fascia and crosstube.
- TE Hitches produced before 04/20/11 are rated at 500/5000 WC.
- TI Hitches produced before 06/06/11 are rated at 400/4000 WC.
- TQ Hitches produced before 07/30/12 are rated at 350/3500 WC.

RECEIVER HITCH APPLICATION GUIDE

T-ONE						TOW HARNESS						4-FLAT WIRING				REQ. 4 FLAT WIRING			BRAKE CONTROL HARNESS	IN	
PC	T-ONE	FN	IN	AMP	CP	PC	TOW HARN	FN	IN	AMP	CP	TYPE	ELEC	POS	CHOICE 1	CHOICE 2	6-WAY ADAPTER	7-WAY ADAPTER			7-WAY HARDWIRE
STERLING TRUCK (Continued)																					
													C	PU1,2	119180	119148	20320	20321	20224		
SUBARU																					
E12	118461	CH	10	2.1,4.2	X								B.E	SUV8	119148	119180	20320	20321	20224		
													B.E	SUV1,2	119148	119180					
													B.E	PC3,4	119148	119180					
													B.E	SUV1,2	119148	119180	20320	20321			
E11	118467	CH	15	2.1,5.6	X								B.E	SUV1,2	119148	119180	20320	20321			
E12	118461	CH	10	2.1,4.2	X								B.E	SUV4	119148	119180					
E11	118467	CH	15	2.1,5.6	X								B.E	SUV8	119148	119180	20320	20321	20224		
													B.E	SUV8	119148	119180	20320	20321	20224		
													B.E	PC1,2	119148	119180					
													B.E	PC1,2	119148	119180					
E17	118464	CH	45	2.1,5.6	X								B.E	PC3,4	119148	119180					
													B.E	PC3,4	119148	119180					
E15	118581	CH	45	2.1,5.6	X								B.E	PC3,4	119148	119180					
E19	118573	CH	45	2.1,5.6	X								B.E	PC3,4	119148	119180					
													B.E	PC3,4	119148	119180					
													B.E	PC3,4	119148	119180					
E12	118461	CH	10	2.1,4.2	X								B.E	PC3,4	119148	119180					
													B.E	PC3,4	119148	119180					
													B.E	PC3,4	119148	119180					
													B.E	PC3,4	119148	119180	20320	20321	20224		
E12	118461	CH	10	2.1,4.2	X								B.E	PC3,4	119148	119180	20320	20321	20224		
													B.E	PC3,4	119148	119180	20320	20321	20224		
E14	118511	CH	45	2.1,5.6	X								B.E	PC3,4	119148	119180	20320	20321	20224		
E15	118671	CH	45	4.2,7.5	X								B.E	PC3,4	119148	119180	20320	20321	20224		
													B.E	PC3,4	119148	119180					
E12	118461	CH	10	2.1,4.2	X								B.E	PC3,4	119148	119180					
													B.E	PC3,4	119148	119180	20320	20321	20224		
E12	118461	CH	10	2.1,4.2	X								B.E	PC3,4	119148	119180	20320	20321	20224		
E11	118467	CH	15	2.1,5.6	X								B.E	PC3	119148	119180	20320	20321	20224		
E12	118461	CH	10	2.1,4.2	X								B.E	SUV8	119148	119180	20320	20321	20224		
E12	118461	CH	10	2.1,4.2	X								B.E	SUV8	119148	119180	20320	20321	20224		
E11	118467	CH	15	2.1,5.6	X								B.E	SUV1,2	119148	119180	20320	20321			
													B.E	SUV1,2	119148	119180	20320	20321			
SUZUKI																					
E14	118525		30	7.5		E21	118266	BN,RD	30			7-Way	H	PU3	119180	20252				3050-P	5
						E9	118267	BN,RD,Z	30			7-Way	B.E	PU3	119148	119180					

B 3 wire system. Converter required.
BN Exterior mounted plug on some or all models. May require an aftermarket electrical mounting box or bracket. (Sold separately)
C 2 or 3 wire system determine at installation.
CH T-One is equipped with circuit protected ModuLite® module.

E ModuLite® required.
H 3 wire system with OEM standard 2 wire harness.
RD For vehicles equipped with factory tow package may require additional components or may be used as a replacement harness.
Z May be equipped with Factory Tow Prep Plug. Determine at time of installation.

RT2 Round Tube Class II 1-1/4"
RT3 Round Tube Class III 2"
SQ1 Square Tube Class I
SQ2 Square Tube Class II
SQ3 Square Tube Class III
SQ5 Square Tube Class V

RECEIVER HITCH APPLICATION GUIDE

MODEL / STYLE	YEAR	TRAILER HITCHES									
		PC	REC TYPE	REC SIZE	PART #	NO DRILL	FOOTNOTES	OPTIONAL DRAWBAR	WC (LBS.)	WD (LBS.)	IN
SUZUKI (Continued)											
Grand Vitara	99-05	29	SQ1	1-1/4	24673	0	HM	3591	200/2,000		15
		29	SQ3	2	41537	0	HM		350/3,500		15
Grand Vitara	06-13	24	SQ1	1-1/4	24764	0	EP, HM	3591	200/2,000		20
		30	SQ3	2	75448	0	EP		350/3,500	400/4,000	20
Sidekick Except Sport Model	96-98	25	SQ1	1-1/4	24622	0	HM	3593	200/2,000		20
Swift+ 5 Dr. (Canada Only)	04-09	20	SQ1	1-1/4	24741		GP	3593	200/2,000		30
SX4 Crossover	07-11	18	SQ1	1-1/4	24817		HM, JR	3594	200/2,000		40
Vitara	99-04	29	SQ1	1-1/4	24673	0	HM	3591	200/2,000		15
		29	SQ3	2	41537	0	HM		350/3,500		15
X-90	96-98	25	SQ1	1-1/4	24622	0	HM, HP	3593	200/2,000		20
XL-7	02-06	29	SQ1	1-1/4	24673	0	HM	3591	200/2,000		15
		29	SQ3	2	41537	0	HM		350/3,500		15
XL-7	07-09	29	SQ3	2	75529	0	HM			400/4,000	30
TOYOTA											
4Runner	96-00	42	RT3	2	75091	0			500/5,000	550/5,500	30
4Runner	01-02	42	RT3	2	75091	0			500/5,000	550/5,500	30
4Runner	03-06	47	RT4	2	75155	0	FE, LT, SI		600/6,000	730/7,300	35
4Runner w/Factory 7-Way	03-06										
4Runner	07-09	47	RT4	2	75155	0	FE, LT, SI		600/6,000	730/7,300	35
4Runner	10-11										
4Runner w/Factory 7-Way	10-11										
4Runner	14-16										
86	17-17	30	SQ1	1-1/4	24935	0		3593	200/2,000		75
Avalon	95-99	23	SQ2	1-1/4	36336		HM	36061	300/3,500		15
Avalon	00-04	43	SQ2	1-1/4	36293		GP	36051	300/3,500		20
Avalon	05-10	52	SQ1	1-1/4	24870	0	HM, JR	3593	200/2,000		40
Avalon	11-12	52	SQ1	1-1/4	24870	0	HM, JR	3593	200/2,000		40
Avalon	13-16	23	SQ2	1-1/4	36540		HM, JR, KH, SV	36071	300/3,500		40
Camry 4 Dr. Sedan	97-01	35	SQ1	1-1/4	24715	0	HM, JR	3593	200/2,000		15
		23	SQ2	1-1/4	36336		HM	36061	300/3,500		15
Camry 4 Dr. Sedan	02-04	35	SQ1	1-1/4	24715	0	HM, JR	3593	200/2,000		15
		23	SQ2	1-1/4	36336		HM	36061	300/3,500		15
Camry 4 Dr. Sedan	05-06	23	SQ2	1-1/4	36336		HM	36061	300/3,500		15
Camry 4 Dr. Sedan, Except Hybrid	07-09	20	SQ2	1-1/4	36416		GP, JR, TA	36071	300/3,500		45
Camry 4 Dr. Sedan, Except Hybrid	10-11	20	SQ2	1-1/4	36416		GP, JR, TA	36071	300/3,500		45
Camry Including Hybrid	12-17	23	SQ2	1-1/4	36540		HM, JR, KH, SV	36071	300/3,500		40
Camry Hybrid 4 Dr. Sedan	07-11	20	SQ2	1-1/4	36416		GP, JR, TA	36071	300/3,500		45
Corolla Sedan	93-02	25	SQ1	1-1/4	24579		GP	3592	200/2,000		30
Corolla	03-03	22	SQ1	1-1/4	248141	0	HM	3593	200/2,000		20
		24	RT1	1-1/4	24913	0	HM	3593	200/2,000		20
Corolla	04-07	22	SQ1	1-1/4	248141	0	HM	3593	200/2,000		20
		24	RT1	1-1/4	24913	0	HM	3593	200/2,000		20
Corolla	08-08	22	SQ1	1-1/4	248141	0	HM	3593	200/2,000		20
		24	RT1	1-1/4	24913	0	HM	3593	200/2,000		20
Corolla	09-13	22	SQ1	1-1/4	248141	0	HM	3593	200/2,000		20
		24	RT1	1-1/4	24913	0	HM	3593	200/2,000		20
Corolla	14-16	24	RT1	1-1/4	24913	0	HM	3593	200/2,000		20
Corolla	17-17	24	RT1	1-1/4	24913	0	HM	3593	200/2,000		20
Echo Except Hatchback	00-02	33	SQ1	1-1/4	24813	0	X, GP	3590	200/2,000		15
Echo Except Hatchback	03-05	33	SQ1	1-1/4	24813	0	X, GP	3590	200/2,000		15
FJ Cruiser	07-14	34	SQ3	2	75461	0	GP		500/5,000	600/6,000	30

- | | | | |
|----|---|----|--|
| EP | Fascia trimming may be required. | KH | Minor heat shield modification may be required. |
| FE | Fascia trimming may be required. Allow additional installation time. | LT | Requires removal of factory hitch if equipped. |
| GP | Hitch cross-tube concealed behind bumper. | SI | Hitches produced before 07/31/07 are rated at 350/3500 WC & 500/5000 WD. |
| HM | Hitch cross-tube is visible beneath bumper. | SV | Trimming or removal of under body appearance panel may be required. |
| HP | Requires four (4) 7/16" x 1" x 2" spacer blocks (#01080012) for installation. (Sold separately) | TA | Trunk access required for hitch installation. |
| JR | Exhaust must be temporarily lowered for installation. | X | Minor fascia trimming required. |

RECEIVER HITCH APPLICATION GUIDE

T-ONE						TOW HARNESS						4-FLAT WIRING				REQ. 4 FLAT WIRING			BRAKE CONTROL HARNESS	IN	
PC	T-ONE	FN	IN	AMP	CP	PC	TOW HARN	FN	IN	AMP	CP	TYPE	ELEC	POS	CHOICE 1	CHOICE 2	6-WAY ADAPTER	7-WAY ADAPTER			7-WAY HARDWIRE
SUZUKI (Continued)																					
E5	118372	HG	5	2.1,5									B	SUV3	119130	119178	20320	20321	20224		
E12	118456	CG	20	2.1,5	X								B	SUV3,4	119130	119178	20320	20321	20224		
E5	118372	HG	5	2.1,5									B	SUV1,2	119130	119178					
													B	PC3,4	119130	119178					
E12	118456	CG	20	2.1,5	X								B	SUV1,2	119130	119178	20320	20321			
E5	118372	HG	5	2.1,5									B	SUV3	119130	119178	20320	20321	20224		
													B	SUV1,2	119130	119178					
E5	118372	HG	5	2.1,5									B	SUV3	119130	119178	20320	20321	20224		
						E7	118432	CE,RD	10	7.5		4-Flat	B	SUV1,2	119130	119178	20320	20321	20224		
TOYOTA																					
E11	118341	HG	20	2.1,5									B,E	SUV3,4	119148	119180	20320	20321	20224		
E11	118341	HG	20	2.1,5		E3	118245	BN,RD	10	7.5		4-Flat	B,E	SUV3,4	119148	119180	20320	20321	20224		
													B	SUV1,2	119130	119178	20320	20321	20224	3040-P	5
							20137	RD	10			Both	B	SUV1,2	118180	20252					
													B,E	SUV1,2	119148	119180	20320	20321	20224	3040-P	5
E8	118384	BN,RD	5	7.5		E12	118262	BN,RD	10			Both	A	SUV5	119180	20252				3040-P	5
E8	118384	BN,RD	5	7.5		E8	118384 20119 118015	BN,RD RD RD	5 10 10	7.5		4-Flat Both 7-Way	A	SUV5	119180	20252				3040-P	5
																				3041-P	10
													B,E	PC3,4	119148	119180					
													B	PC3,4	119130	119178					
													B,E	PC3,4	119148	119180					
													B	PC3,4	119130	119178					
E17	118482	CH	45	2.1,5,6	X								B,E	PC3,4	119148	119180					
E16	118578	CH	45	4.2,7,5	X								B,E	PC3,4	119148	119180					
E8	118358	HG	5	2.1,5									B	PC3,4	119130	119178					
E10	118308		5	2.1,5									B	PC3,4	119130	119178					
E10	118308		5	2.1,5									B	PC3,4	119130	119178					
E16	118405	CH	45	2.1,5,6	X								B,E	PC3,4	119148	119180					
E17	118482	CH	45	2.1,5,6	X								B,E	PC3,4	119148	119180					
E16	118405	CH	45	2.1,5,6	X								B,E	PC3,4	119148	119180					
E17	118482	CH	45	2.1,5,6	X								B,E	PC3,4	119148	119180					
													B	PC3,4	119130	119178					
E13	118387	CG	15	2.1,5	X								B	PC3,4	119130	119178					
													B	PC3,4	119130	119178					
													B,E	PC3,4	119148	119180					
E16	118459	CH	45	2.1,4,2	X								B,E	PC3,4	119148	119180					
E16	118405	CH	45	2.1,5,6	X								B,E	PC3,4	119148	119180					
													B	PC3,4	119130	119178					
E12	118386	CG	20	2.1,5	X								B	PC3,4	119130	119178					
													B	PC3,4	119130	119178					
E16	118405	CH	45	2.1,5,6	X								B	SUV3,4	119130	119178	20320	20321	20224		

- A** 2 wire system.
- B** 3 wire system. Converter required.
- BN** Exterior mounted plug on some or all models. May require an aftermarket electrical mounting box or bracket. (Sold separately)
- CE** T-One includes fuse(s) & relay(s). Converter not required. Standard 2 wire system at factory tow plug.
- CG** T-One incorporates circuit protected taillight converter.
- CH** T-One is equipped with circuit protected ModuLite® module.
- E** ModuLite® required.
- HG** T-One incorporates taillight converter.
- RD** For vehicles equipped with factory tow package may require additional components or may be used as a replacement harness.

- RT1** Round Tube Class I 1-1/4"
- RT3** Round Tube Class III 2"
- RT4** Round Tube Class IV 2"
- SQ1** Square Tube Class I
- SQ2** Square Tube Class II
- SQ3** Square Tube Class III

RECEIVER HITCH APPLICATION GUIDE

MODEL / STYLE	YEAR	TRAILER HITCHES									
		PC	REC TYPE	REC SIZE	PART #	NO DRILL	FOOTNOTES	OPTIONAL DRAWBAR	WC (LBS.)	WD (LBS.)	IN
TOYOTA (Continued)											
Highlander	01-03	39	SQ2	1-1/4	36271	0	HM	36051	300/3,500		15
		35	SQ3	2	41541	0	HM		300/3,500		15
Highlander	04-07	32	RT3	2	75153	0	HM		350/3,500		20
Highlander Except Hybrid	04-07										
Highlander	08-13	45	RT3	2	75726	0	HM,SV		750/5,000	750/5,000	40
Highlander Except w/Full Size 19" Spare Tire	08-13	35	SQ3	2	75586	0	HM		500/5,000	500/5,000	25
Highlander	14-16	39	RT4	2	75896	0	HM,SV		900/6,000	900/8,000	30
Hilux	08-12	53	SQ4	2	75730	0	AA,GP		900/6,000	900/9,000	60
Hilux	13-14	53	SQ4	2	75730	0	AA,GP		900/6,000	900/9,000	60
Hilux	16-16	38	SQ4	2	75791	0	HM		800/8,000	800/8,000	45
Hilux SW4	14-14	38	SQ3	2	75914	0	HM		525/3,500		15
Land Cruiser	96-97	54	SQ3	2	41015	0	HM		500/5,000	750/6,000	30
Land Cruiser	98-99	45	SQ3	2	75095	0	GP		500/5,000	750/6,000	20
Land Cruiser	00-00	45	SQ3	2	75095	0	GP		500/5,000	750/6,000	20
Land Cruiser	01-02	45	SQ3	2	75095	0	GP		500/5,000	750/6,000	20
Land Cruiser	03-07	45	SQ3	2	75095	0	GP		500/5,000	750/6,000	20
Matrix	03-08	15	SQ1	1-1/4	24812	0	HM,UD	3593	200/2,000		15
Matrix	09-13	15	SQ1	1-1/4	24812	0	HM	3593	200/2,000		15
Matrix (Canada Only)	14-14	15	SQ1	1-1/4	24812	0	HM	3593	200/2,000		15
Prado	14-14	38	SQ3	2	75904	0	GP		825/5,000		15
Prius	04-09	24	SQ1	1-1/4	24808	0	HM,SC	3593	200/2,000		30
Prius Except w/Plug-In Model	10-15	18	SQ1	1-1/4	24847	0	HM,JR	3593	200/2,000		25
Prius	16-17	16	SQ1	1-1/4	24944	0	DU,GP,SV	3593	200/2,000		45
Prius C	12-15	23	SQ1	1-1/4	24889	0	GP	3593	200/2,000		20
Prius V	12-17	18	SQ1	1-1/4	24847	0	HM,JR	3593	200/2,000		25
RAV4	96-00	31	SQ1	1-1/4	24704	0	HM	3593	200/2,000		15
		31	SQ3	2	75125	0	RA		350/3,500		15
RAV4	01-05	31	SQ1	1-1/4	24704	0	HM	3593	200/2,000		15
		31	SQ3	2	75125	0			350/3,500		15
RAV4	06-12	24	RT2	1-1/4	36588	0	HM,JR,SV	36051	300/3,500		20
		20	RT3	2	75235	0	HM,JR,SV		675/4,500	675/4,500	20
RAV4	13-15	24	RT2	1-1/4	36588	0	HM,JR,SV	36051	300/3,500		20
RAV4	13-17	20	RT3	2	75235	0	HM,JR,SV		675/4,500	675/4,500	20
Sequoia	01-02	57	SQ3	2	75126	0	CP		500/5,000	650/6,500	20
Sequoia	03-07	57	SQ3	2	75126	0	CP		500/5,000	650/6,500	20
Sequoia w/Factory 7-Way	03-04										
Sequoia	08-10	19	SQ4	2	75649	0	AI		600/6,000	1,000/10,000	40
Sequoia	11-16	19	SQ4	2	75649	0	AI		600/6,000	1,000/10,000	40
Sienna	98-03	34	SQ2	1-1/4	36298	0	GP	36053	300/3,500		15
		34	SQ3	2	75120				350/3,500	500/5,000	30
Sienna	04-10	27	RT2	1-1/4	36513	0	HM,JR	36051	300/3,500		20
		24	RT3	2	75237	0	HM,SV,JR,SY		675/4,500	675/5,000	30
Sienna	11-14	27	RT2	1-1/4	36513	0	HM,JR,SV,SY	36051	300/3,500		20
		24	RT3	2	75237	0	HM,SV,JR,SY		675/4,500	675/5,000	30
		32	SQ4	2	76112	0	SV,JR,GP,TA,DU		525/3,500		60
Sienna Except SE	15-17	27	RT2	1-1/4	36513	0	HM,JR,SV,SY	36051	300/3,500		20
		24	RT3	2	75237	0	HM,SV,JR,SY		675/4,500	675/5,000	30
		32	SQ4	2	76112	0	SV,JR,GP,TA,DU		525/3,500		60
Sienna SE	15-17	27	RT2	1-1/4	36513	0	HM,JR,SV,SY	36051	300/3,500		20
		24	RT3	2	75237	0	HM,SV,JR,SY		675/4,500	675/5,000	30
		32	SQ4	2	76112	0	SV,JR,GP,TA,DU		525/3,500		60
Solara	99-03	35	SQ1	1-1/4	24715	0	HM,JR	3593	200/2,000		15
		23	SQ2	1-1/4	36336		HM	36061	300/3,500		15

- AA** Requires temporary removal of bumper during installation.
- AI** Additional installation time may be required.
- CP** Fits all models without factory installed receiver.
- DU** Fascia removal required.
- GP** Hitch crosstube concealed behind bumper.
- HM** Hitch crosstube is visible beneath bumper.
- JR** Exhaust must be temporarily lowered for installation.

- RA** Do not install on early 1996 models equipped with M10 fasteners.
- SC** Minor trimming of plastic trunk pan required.
- SV** Trimming or removal of under body appearance panel may be required.
- SY** Hitch crosstube is visible beneath bumper with a more than normal gap between fascia and crosstube.
- TA** Trunk access required for hitch installation.
- UD** Fascia removal required on XR & XRS models.

RECEIVER HITCH APPLICATION GUIDE

T

TOYOTA

T-ONE						TOW HARNESS						4-FLAT WIRING				REQ. 4 FLAT WIRING		BRAKE CONTROL HARNESS	IN	
PC	T-ONE	FN	IN	AMP	CP	PC	TOW HARN	FN	IN	AMP	CP	TYPE	ELEC	POS	CHOICE 1	CHOICE 2	6-WAY ADAPTER			7-WAY ADAPTER
TOYOTA (Continued)																				
E10	118413	HG	20	2.1,4.2		E3	118245	BN,RD	10	7.5		4-Flat	B,Z	SUV3,4	119178	119130	20320	20321	20224	
E10	118248	CH	20	2.1,4.2	X	E10	118248	RD	20	2.1,4.2	X	4-Flat	B	SUV3	119130	119178	20320	20321	20224	
E10	118413	HG	20	2.1,4.2									B	SUV3,4	119130	118178				
E13	118449	CH	20	2.1,4.2	X								B,E	SUV3,4	119148	119180	20320	20321	20224	
E13	118449	CH	20	2.1,4.2	X								B,E	SUV3,4	119148	119180	20320	20321	20224	
E13	118449	CH	20	2.1,4.2	X								B,E	SUV3,4	119148	119180	20320	20321	20224	
E13	118496	HG	10	2.1,7.5									B	PU3,4	119130	119178	20320	20321	20224	
													B	PU3,4	119130	119178	20320	20321	20224	
													B,E	PU3,4	119148	119180				
													B,E	PU3,4	119148	119180	20320	20321		
E5	118357	BN,HG	5	2.1,5									B	SUV6	119130	119178	20320	20321	20224	
E5	118365	BN,HG	5	2.1,5									B	SUV6	119130	119178	20320	20321	20224	
													B	SUV6	119130	119178	20320	20321	20224	
						E3	118245	BN,RD	10	7.5		4-Flat	B	SUV6	119130	119178	20320	20321	20224	
													B	SUV6	119130	119178	20320	20321	20224	
E12	118386	CG	20	2.1,5	X								B	SUV3,4	119130	119178				
E16	118460	CH	45	2.1,4.2	X								B,E	SUV3,4	119148	119180	20320	20321		
													B,E	SUV3,4	119148	119180	20320	20321		
													B,E	SUV3,4	119148	119180	20320	20321		
E16	118505	CH	25	2.1,5.6	X								B,E	PC3,4	119148	119180				
E16	118505	CH	25	2.1,5.6	X								B,E	PC3,4	119148	119180				
E17	118701	CH	45	4.2,7.5	X								B,E	PC3,4	119148	119180				
E13	118680	CH	25	4.2,7.5	X								B,E	PC3,4	119148	119180				
E13	118610	CH	45	2.1,5.6	X								B,E	PC3,4	119148	119180				
E12	118388	CG	20	2.1,5	X								B	SUV3,4	119130	119178	20320	20321	20224	
E12	118389	CG	20	2.1,5	X								B	SUV3,4	119130	119178	20320	20321	20224	
E16	118412	CH	45	2.1,4.2	X								B,E	SUV3,4	119148	119180	20320	20321	20224	
E16	118578	CH	45	4.2,7.5	X								B,E	SUV3,4	119148	119180	20320	20321	20224	
E16	118578	CH	45	4.2,7.5	X								B,E	SUV3,4	119148	119180	20320	20321	20224	
						E1	118246	BN,RD	5	7.5		4-Flat	B	SUV7	119130	119178	20320	20321	20224	
													D			119251	20320	20321		3040-P 5
							20137	RD	10			Both	RD	SUV6		119251				
E16	118412	CH	45	2.1,4.2	X								N	SUV3,4		119251	20320	20321		3040-P 5
													D			119251	20320	20321		3040-P 5
													B	SUV3,4	119130	119178	20320	20321	20224	
E10	118304		20	2.1,4.2									B	SUV1,2	119130	119178	20320	20321	20224	
E18	118498	CH	45	2.1,5.6	X								B,E	SUV1,2	119148	119180	20320	20321	20224	
E16	118648	CH	45	4.2,7.5	X								B,E	SUV1,2	119148	119180	20320	20321	20224	
E18	118498	CH	45	2.1,5.6	X								B,E	SUV1,2	119148	119180	20320	20321	20224	
													B	PC3,4	119130	119178				

B 3 wire system. Converter required.

BN Exterior mounted plug on some or all models. May require an aftermarket electrical mounting box or bracket. (Sold separately)

CG T-One incorporates circuit protected taillight converter.

CH T-One is equipped with circuit protected ModuLite® module.

D See auto dealer for trailer tow wiring kit.

E ModuLite® required.

HG T-One incorporates taillight converter.

N DO NOT cut or splice vehicle wiring. Only use approved T-One or see auto dealer for trailer tow wiring kit.

RD For vehicles equipped with factory tow package may require additional components or may be used as a replacement harness.

Z May be equipped with Factory Tow Prep Plug. Determine at time of installation.

RT2 Round Tube Class II 1-1/4"

RT3 Round Tube Class III 2"

RT4 Round Tube Class IV 2"

SQ1 Square Tube Class I

SQ2 Square Tube Class II

SQ3 Square Tube Class III

SQ4 Square Tube Class IV

RECEIVER HITCHES

RECEIVER HITCH APPLICATION GUIDE

MODEL / STYLE	YEAR	TRAILER HITCHES									
		PC	REC TYPE	REC SIZE	PART #	NO DRILL	FOOTNOTES	OPTIONAL DRAWBAR	WC (LBS.)	WD (LBS.)	IN
TOYOTA (Continued)											
Solara	04-06	39	SQ2	1-1/4	36378	0	JR,HM	36061	300/3,500		15
Solara	07-08	39	SQ2	1-1/4	36378	0	JR,HM	36061	300/3,500		15
T100	93-98	59	SQ3	2	75144	0	CN		500/5,000	700/7,000	45
Tacoma (App. starts with 95-1/2)	95-04	32	SQ3	2	75078	0	GP		500/5,000	550/5,500	40
Tacoma Except X-Runner	05-08	18	SQ3	2	75236	0	GP		500/5,000	550/5,500	30
Tacoma Except X-Runner	09-15	18	SQ3	2	75236	0	GP		500/5,000	550/5,500	30
Tacoma w/Factory 7-Way	09-12										
Tacoma	16-17	20	SQ4	2	75238	0	GP		1,050/7,000	1,200/8,000	20
Terrel Sedan	91-98	31	SQ1	1-1/4	24606	0	HM	3593	200/2,000		30
Tundra	00-00	49	RT3	2	37133				500/5,000	750/7,500	35
		54	RT4	2	37130				700/7,000	1,200/12,000	30
Tundra Except Models w/Towable Bumper	00-00	30	SQ3	2	75105	0	GP		500/5,000	750/7,500	15
Tundra	01-02	49	RT3	2	37133				500/5,000	750/7,500	35
		54	RT4	2	37130				700/7,000	1,200/12,000	30
Tundra Except Models w/Towable Bumper	01-02	30	SQ3	2	75105	0	GP		500/5,000	750/7,500	15
Tundra	03-06	49	RT3	2	37133				500/5,000	750/7,500	35
		54	RT4	2	37130				700/7,000	1,200/12,000	30
Tundra Except Models w/Towable Bumper	03-06	30	SQ3	2	75105	0	GP		500/5,000	750/7,500	15
Tundra w/Factory 7-Way	03-06										
Tundra (See Footnote CP)	07-09	25	RT4	2	75527	0	CP,HM		600/6,000	800/8,000	20
		70	SQ5	2	41935	0	@,CP,HM		1,200/12,000	1,400/14,000	30
Tundra (See Footnote CP)	10-14	25	RT4	2	75527	0	CP,HM		600/6,000	800/8,000	20
		70	SQ5	2	41935	0	@,CP,HM		1,200/12,000	1,400/14,000	30
Tundra w/Factory 7-Way	10-13										
Tundra (See Footnote CP)	15-17	25	RT4	2	75527	0	CP,HM		600/6,000	800/8,000	20
		70	SQ5	2	41935	0	@,CP,HM		1,200/12,000	1,400/14,000	30
Venza	09-16	29	RT2	1-1/4	36512	0	HM,JR	36061	300/3,500		20
		38	RT3	2	75663	0	HM,JR		350/3,500	400/4,000	20
Yaris 3 Dr. Liftback	07-11	11	SQ1	1-1/4	24819	0	GP	3593	200/2,000		20
Yaris 3 Dr. Liftback	07-14	14	SQ1	1-1/4	24911	0	GP	3593	200/2,000		20
Yaris 4 Dr. Sedan	07-11	11	SQ1	1-1/4	24819	0	GP	3593	200/2,000		20
Yaris 5 Dr. Liftback, Except SE	07-14	14	SQ1	1-1/4	24911	0	GP	3593	200/2,000		20
Yaris 5 Dr. Liftback	09-11	11	SQ1	1-1/4	24819	0	GP	3593	200/2,000		20
Yaris Except SE	15-17	16	SQ1	1-1/4	24929	0	GP,EP	3593	200/2,000		25
Yaris iA	17-17	32	RT1	1-1/4	24948	0	HM	3593	200/2,000		30
VOLKSWAGEN											
Amarok (International Only)	13-13	59	SQ3	2	75808	0	HM		600/4,000	800/8,000	30
Beetle	98-01	39	SQ1	1-1/4	24679		TA,GP	3593	200/2,000		30
Beetle Except Turbo S	02-10	39	SQ1	1-1/4	24679		TA,GP	3593	200/2,000		30
Beetle Except Convertible & Gas Turbo	12-13	28	SQ1	1-1/4	24877	0	HM,JR	3594	200/2,000		20
Beetle Gas Turbo, Except Convertible	12-13	29	SQ1	1-1/4	24879		GP,JR	3594	200/2,000		30
Beetle Except R-Line & GSR	14-16	28	SQ1	1-1/4	24922	0	HM	3593	200/2,000		20
CC Except 4 Motion	09-12	22	SQ1	1-1/4	24848		HM,JR,X	3594	200/2,000		35
CC Except 4 Motion	13-16	22	SQ1	1-1/4	24848		HM,JR,X	3594	200/2,000		35
Eos	07-13	25	SQ1	1-1/4	24824	0	GP,JR	3594	200/2,000		40
Golf	99-06	39	SQ1	1-1/4	24679		TA,GP	3594	200/2,000		30
Golf 2 Dr. Hatchback, Except R	10-13	19	SQ1	1-1/4	24825	0	HM	3594	200/2,000		15
Golf 4 Dr. Hatchback, Except R	10-14	19	SQ1	1-1/4	24825	0	HM	3594	200/2,000		15
Golf Hatchback (Canada Only), Except R	10-13	19	SQ1	1-1/4	24825	0	HM	3594	200/2,000		15
Golf Wagon (Canada Only)	10-14	23	SQ1	1-1/4	24866	0	HM,JR,TA	3594	200/2,000		40
Golf Except GTI & Sportwagen Models	15-16	25	SQ1	1-1/4	24925	0	TA,FE	3593	200/2,000		60

@ Ultra Frame ball mount must be used to achieve maximum weight carrying rating.
 CN Requires OEM factory bumper for hitch installation.
 CP Fits all models without factory installed receiver.
 EP Fascia trimming may be required.
 FE Fascia trimming may be required. Allow additional installation time.

GP Hitch cross-tube concealed behind bumper.
 HM Hitch cross-tube is visible beneath bumper.
 JR Exhaust must be temporarily lowered for installation.
 TA Trunk access required for hitch installation.
 X Minor fascia trimming required.

RECEIVER HITCH APPLICATION GUIDE

V

VOLKSWAGEN

T-ONE						TOW HARNESS						4-FLAT WIRING				REQ. 4 FLAT WIRING			BRAKE CONTROL HARNESS	IN		
PC	T-ONE	FN	IN	AMP	CP	PC	TOW HARN	FN	IN	AMP	CP	TYPE	ELEC	POS	CHOICE 1	CHOICE 2	6-WAY ADAPTER	7-WAY ADAPTER			7-WAY HARDWIRE	
TOYOTA (Continued)																						
													B	PC3,4	119130	119178						
													B,E	PC3,4	119148	119180						
E13	118496	HG	10	2.1,7.5									B	PU3,4	119130	119178	20320	20321	20224			
E14	118379	BN,HG	10	2.1,5									B	PU1,2	119130	119178	20320	20321	20224			
E13	118496	HG	10	2.1,7.5									B	PU1,2	119130	119178	20320	20321	20224	3040-P	5	
E13	118496	HG	10	2.1,7.5		E8	118384	BN,RD	5	7.5		4-Flat	B,E	PU1,2	119148	119180	20320	20321	20224	3040-P	5	
							20119	RD	10			Both	H	PU3	119180	20252						
							118015	RD	10			7-Way										
E21	118685	BN,CH	45	5,7.5	X								B,E	PU1,2	119148	119180					3017-P	5
													B	PC3,4	119130	119178						
E15	118367	BN,CH	10	7.5									B,E	PU3	119148	119180	20320	20321	20224			
E15	118367	BN,CH	10	7.5									B,E	PU3	119148	119180	20320	20321	20224			
E17	118378	BN,CH	10	7.5									B,E	PU3	119148	119180	20320	20321	20224			
E17	118378	BN,CH	10	7.5									B,E	PU3	119148	119180	20320	20321	20224			
													B,E	PU3,4	119148	119180	20320	20321	20224	3040-P	5	
													B,E	PU3,4	119148	119180	20320	20321	20224	3040-P	5	
							20137	RD	10			Both	B,E	PU3,4	119148	119180						
													A	PU3	119180	20252	20320	20321	20224	3040-P	5	
						E8	118384	BN,RD	5	7.5		4-Flat	A	PU3	119180	20252	20320	20321	20224	3040-P	5	
							20119	RD	10			Both	H	PU3	119180	20252						
							118015	RD	10			7-Way										
						E8	118384	BN,RD	5	7.5		4-Flat	A	PU3	119180	20252	20320	20321	20224	3017-P	5	
E17	118482	CH	45	2.1,5,6	X								B,E	SUV3,4	119148	119180	20320	20321	20224			
													B	PC3,4	119130	119178						
													B	PC3,4	119130	119178						
E18	118517	CH	45	2.1,5,6	X								B	PC3,4	119130	119178						
													B	PC3,4	119130	119178						
													B	PC3,4	119130	119178						
E16	118661	CH	45	4,2,7.5	X								B,E	PC3,4	119148	119180						
E15	118728	CH,BN	45	5,7.5	X								B,E	PC1,2	119148	119180						
VOLKSWAGEN																						
													BM	PU3	119251	119191	20320	20321				
													B	PC1,2	119130	119178						
													B	PC1,2	119130	119178						
E17	118688	CH	45	4,2,7.5	X								B,E	PC3,4	119251	119191						
E17	118688	CH	45	4,2,7.5	X								B,E	PC3,4	119251	119191						
E17	118688	CH	45	4,2,7.5	X								B,E	PC3,4	119251	119191						
													BT	PC1,2	119251	119191						
E16	118714	CH	45	4,2,7.5	X								A,E	PC3,4	119251	119180						
													BM	PC3,4	119251	119191						
													B	PC1,2	119130	119178						
													BT	PC1,2	119251	119191						
													BT	PC1,2	119251	119191						
													BT	PC1,2	119251	119191						
													BM	PC3,4	119251	119191						
E20	118646	CH	45	4,2,7.5	X								BTT	PC3,4	119251	119191						

- A** 2 wire system.
- B** 3 wire system. Converter required.
- BM** Multiplexed wiring system. ModuLite® HD Plus or Ultra required.
- BN** Exterior mounted plug on some or all models. May require an aftermarket electrical mounting box or bracket. (Sold separately)
- BT** Shared Brake/Tail multiplexed wiring system. ModuLite® HD Plus or Ultra required.
- BTT** Shared Brake/Tail/Turn multiplexed wiring system. ModuLite® HD Plus or Ultra required.

- CH** T-One is equipped with circuit protected ModuLite® module.
- E** ModuLite® required.
- H** 3 wire system with OEM standard 2 wire harness.
- HG** T-One incorporates taillight converter.
- RD** For vehicles equipped with factory tow package may require additional components or may be used as a replacement harness.

- RT1** Round Tube Class I 1-1/4"
- RT2** Round Tube Class II 1-1/4"
- RT3** Round Tube Class III 2"
- RT4** Round Tube Class IV 2"
- SQ1** Square Tube Class I
- SQ2** Square Tube Class II
- SQ3** Square Tube Class III
- SQ4** Square Tube Class IV
- SQ5** Square Tube Class V

RECEIVER HITCHES

RECEIVER HITCH APPLICATION GUIDE

MODEL / STYLE	YEAR	TRAILER HITCHES									
		PC	REC TYPE	REC SIZE	PART #	NO DRILL	FOOTNOTES	OPTIONAL DRAWBAR	WC (LBS.)	WD (LBS.)	IN
VOLKSWAGEN (Continued)											
Golf City (Canada Only)	07-10	39	SQ1	1-1/4	24679		TA,GP	3594	200/2,000		30
Golf SportWagen	15-15	19	SQ1	1-1/4	24949	0	EP,GP,DU,AA	3590	200/2,000		60
Golf SportWagen	16-17	19	SQ1	1-1/4	24949	0	EP,GP,DU,AA	3590	200/2,000		60
GTI 2 Dr. Hatchback	06-09	19	SQ1	1-1/4	24825	0	HM	3594	200/2,000		15
GTI 4 Dr. Hatchback	07-09	19	SQ1	1-1/4	24825	0	HM	3594	200/2,000		15
GTI Hatchback	10-14	28	SQ1	1-1/4	24904	0	JR,KH,GP	3594	200/2,000		40
GTI Hatchback (Canada Only)	10-12	28	SQ1	1-1/4	24904	0	JR,KH,GP	3594	200/2,000		40
Jetta Jetta III	94-98	35	SQ1	1-1/4	24594		GP	3592	200/2,000		30
Jetta Sedan, Except Gas Turbo & Wagon	99-04	29	SQ1	1-1/4	24748		TA,HM	3593	200/2,000		30
Jetta 4 Dr. Sedan	05-10	23	SQ1	1-1/4	24866	0	HM,JR,TA	3594	200/2,000		40
Jetta Sedan, Except Gas Turbo & Wagon	05-05	29	SQ1	1-1/4	24748		TA,HM	3593	200/2,000		30
Jetta SportWagen	09-14	23	SQ1	1-1/4	24866	0	HM,JR,TA	3594	200/2,000		40
Jetta 4 Dr. Sedan	11-14	23	SQ1	1-1/4	24866	0	HM,JR,TA	3594	200/2,000		40
Jetta 4 Dr. Sedan, Except Hybrid & TDI	15-16	33	RT1	1-1/4	24926	0	JR,HM,TA,SV	3593	200/2,000		40
Jetta City Sedan (Canada Only)	07-09	29	SQ1	1-1/4	24748		TA,HM	3593	200/2,000		30
Passat 4 Dr. Sedan, Except 4 Motion & W8 Engine	99-05	20	SQ1	1-1/4	24698		RB,TA,HM	3593	200/2,000		40
Passat Wagon, Except 4 Motion & W8 Engine	99-05	20	SQ1	1-1/4	24698		RB,TA,HM	3593	200/2,000		40
Passat 4 Dr. Sedan, Except 4 Motion	06-10	22	SQ1	1-1/4	24848		HM,JR,X	3594	200/2,000		35
Passat Wagon, Except 4 Motion	07-10	22	SQ1	1-1/4	24848		HM,JR,X	3594	200/2,000		35
Passat 4 Dr. Sedan	12-17	34	SQ1	1-1/4	24880	0	EP,GP,JR,SV,TA	3590	200/2,000		30
Rabbit	06-09	19	SQ1	1-1/4	24825	0	HM	3594	200/2,000		15
Routan	09-12	24	SQ2	1-1/4	36455	0	GP,JR	36061	300/3,500		20
		21	SQ3	2	75579	0	GP,JR		400/4,000	500/5,000	20
Routan (Canada Only)	13-14	24	SQ2	1-1/4	36455	0	GP,JR	36061	300/3,500		20
		21	SQ3	2	75579	0	GP,JR		400/4,000	500/5,000	20
Tiguan	09-11	10	SQ2	1-1/4	36474	0	EP,HM	36051	300/3,500		20
		10	SQ3	2	75658	0	EP		350/3,500		20
Tiguan	12-16	10	SQ2	1-1/4	36474	0	EP,HM	36051	300/3,500		20
		10	SQ3	2	75658	0	EP		350/3,500		20
Touareg	04-10	47	SQ4	2	75363		AA,RB		600/6,000	600/6,000	90
Touareg	11-17	45	SQ4	2	75950	0	GP,EP,TA		750/7,500		70
VOLVO											
850 Sedan	93-97	29	SQ2	1-1/4	36262		GP,JR	36061	300/3,500		20
850 Wagon	94-97	29	SQ2	1-1/4	36262	0	GP	36061	300/3,500		20
C30	08-10	28	SQ1	1-1/4	24811		HM,JR,KH	3593	200/2,000		45
C70 Convertible	98-04	29	SQ2	1-1/4	36262		GP,JR	36061	300/3,500		20
C70 Coupe	98-02	29	SQ2	1-1/4	36262		GP,JR	36061	300/3,500		20
S40 Sedan (App. starts with 2004-1/2)	04-11	27	SQ1	1-1/4	24781	0	GP,JR	3594	200/2,000		25
S60 Sedan	01-09	37	SQ2	1-1/4	36297	0	HM,JR	36061	300/3,500		15
S60 Sedan	11-17	27	SQ3	2	75916	0	DU,EP,GP		400/4,000		70
S70 Sedan	98-00	29	SQ2	1-1/4	36262		GP,JR	36061	300/3,500		20
S80 Sedan	07-16	24	SQ2	1-1/4	36466	0	HM,JR,KH	36061	300/3,500		35
V50 Wagon, Except T5 R-Design	05-11	27	SQ1	1-1/4	24781	0	GP,JR	3594	200/2,000		25
V60 (App. starts with 2015-1/2)	15-16	27	SQ3	2	75916	0	DU,EP,GP		400/4,000		70
V70 Wagon	98-00	29	SQ2	1-1/4	36262	0	GP	36061	300/3,500		20
V70 Wagon	01-02	37	SQ2	1-1/4	36297	0	HM,JR	36061	300/3,500		15
V70 Wagon	03-07	37	SQ2	1-1/4	36297	0	HM,JR	36061	300/3,500		15
V70 Wagon	08-10	27	SQ3	2	75916	0	DU,EP,GP		400/4,000		70
XC60	10-17	33	SQ3	2	75671	0	GP,JR,KH,SR		400/4,000	450/4,500	45
XC70 Wagon, AWD	03-07	37	SQ2	1-1/4	36297	0	HM,JR	36061	300/3,500		15
XC70 Wagon, AWD	08-16	27	SQ3	2	75916	0	DU,EP,GP		400/4,000		70
XC90	03-04	36	SQ3	2	75152	0	JR		500/5,000	500/5,000	25
XC90	05-14	36	SQ3	2	75152	0	JR		500/5,000	500/5,000	25

AA Requires temporary removal of bumper during installation.
 DU Fascia removal required.
 EP Fascia trimming may be required.
 GP Hitch crosstube concealed behind bumper.
 HM Hitch crosstube is visible beneath bumper.
 JR Exhaust must be temporarily lowered for installation.

KH Minor heat shield modification may be required.
 RB Hitch installation can be made easier with a "cutter" type drill bit.
 SR Only use ball mounts with 8-1/2" length : 3/4" rise : 2" drop for this vehicle.
 SV Trimming or removal of under body appearance panel may be required.
 TA Trunk access required for hitch installation.
 X Minor fascia trimming required.

RECEIVER HITCH APPLICATION GUIDE

V

VOLVO

T-ONE						TOW HARNESS						4-FLAT WIRING				REQ. 4 FLAT WIRING		BRAKE CONTROL HARNESS	IN	
PC	T-ONE	FN	IN	AMP	CP	PC	TOW HARN	FN	IN	AMP	CP	TYPE	ELEC	POS	CHOICE 1	CHOICE 2	6-WAY ADAPTER			7-WAY ADAPTER
VOLKSWAGEN (Continued)																				
													B	PC1,2	119130	119178				
													A,E	PC3,4	119180	119180				
E17	118730	CH	45	5,7.5	X								A,E	PC3,4	119148	119180				
													BTT	PC1,2	119192	119191				
													BTT	PC1,2	119251	119191				
													BM	PC3,4	119251	119191				
													BM	PC3,4	119251	119191				
													B	PC3,4	119130	119178				
													B	PC3,4	119130	119178				
E22	118667	CH	45	4,2,7.5	X								BTT	PC3,4	119251	119191				
													B	PC3,4	119130	119178				
													B,E	PC3,4	119148	119180				
E27	118572	CH	45	4,2,7.5	X								B,E	PC3,4	119148	119180				
													B,E	PC3,4	119148	119180				
													B	PC3,4	119130	119178				
													B	PC3,4	119130	119178				
													B	PC3,4	119130	119178				
E25	118562	CH	45	4,2,7.5	X								BM	PC1,2	119251	119191				
E22	118530	CH	45	4,2,7.5	X								BM	PC1,2	119251	119191				
													BM	PC3,4	119251	119191				
													BTT	PC1,2	119251	119191				
E7	118490		20	7.5									A	SUV1,2	119180	20252	20320	20321	20224	
													A	SUV1,2	119180	20252	20320	20321	20224	
													BT	SUV1,2	119251	119191	20320	20321		
E20	118675	CH,BN	45	4,2,7.5	X								BTT	SUV1,2	119251	119191	20320	20321	20224	
E24	118509	CH	45	4,2,7.5	X								B,E	SUV3,4	119148	119180	20320	20321	20224	
E18	118668	CH	45	4,2,7.5	X								BTT	SUV1,2	119192	119191	20320	20321	20224	
VOLVO																				
													E	PC3,4	119180	119148				
													E	PC3,4	119180	119148				
													B,E	PC3,4	119148	119180				
													E	PC3,4	119180	119148				
													E	PC3,4	119180	119148				
													B,E	PC3,4	119148	119180				
													E	PC3,4	119180	119148				
													B,E	PC3,4	119148	119180	20320	20321		
E19	118454	CH	45	2,1,5,6	X								E	PC3,4	119180	119148				
													B,E	PC3,4	119148	119180				
													E	PC3,4	119180	119148				
E16	118647	CH	45	4,2,7.5	X								B,E	PC3,4	119148	119180				
													E	PC1,2	119180	119148				
													E	PC1,2	119180	119148				
													B,E	PC1,2	119148	119180				
E15	118463	CH	45	2,1,5,6	X								B,E	SUV3,4	119148	119180	20320	20321	20224	
E20	118523	CH	45	4,2,7.5	X								B,E	SUV3,4	119148	119180	20320	20321	20224	
													B,E	PC1,2	119148	119180				
													B,E	SUV3,4	119148	119180	20320	20321	20224	
													B,E	SUV3,4	119148	119180	20320	20321	20224	
E18	118411	CH	20	2,1,5,6	X								B,E	SUV3,4	119148	119180	20320	20321	20224	

A 2 wire system.
B 3 wire system. Converter required.
BM Multiplexed wiring system. ModuLite® HD Plus or Ultra required.
BN Exterior mounted plug on some or all models. May require an aftermarket electrical mounting box or bracket. (Sold separately)

BT Shared Brake/Tail multiplexed wiring system. ModuLite® HD Plus or Ultra required.
BTT Shared Brake/Tail/Turn multiplexed wiring system. ModuLite® HD Plus or Ultra required.
CH T-One is equipped with circuit protected ModuLite® module.
E ModuLite® required.

RT1 Round Tube Class I 1-1/4"
SQ1 Square Tube Class I
SQ2 Square Tube Class II
SQ3 Square Tube Class III
SQ4 Square Tube Class IV

RECEIVER HITCHES

RECEIVER HITCH APPLICATION GUIDE FOOTNOTES

ELECTRICAL APPLICATION FOOTNOTES

A	2 wire system.
B	3 wire system. Converter required.
BM	Multiplexed wiring system. ModuLite® HD Plus or Ultra required.
BN	Exterior mounted plug on some or all models. May require an aftermarket electrical mounting box or bracket. (Sold separately)
BT	Shared Brake/Tail multiplexed wiring system. ModuLite® HD Plus or Ultra required.
BTT	Shared Brake/Tail/Turn multiplexed wiring system. ModuLite® HD Plus or Ultra required.
C	2 or 3 wire system determine at installation.
CE	T-One includes fuse(s) & relay(s). Converter not required. Standard 2 wire system at factory tow plug.
CG	T-One incorporates circuit protected taillight converter.
CH	T-One is equipped with circuit protected ModuLite® module.
D	See auto dealer for trailer tow wiring kit.
E	ModuLite® required.
FV	2003 Models w/Build date after 11/1/02.
FW	2003 Models w/Build date before 11/1/02.
G	Low-side switching system.
H	3 wire system with OEM standard 2 wire harness.
HG	T-One incorporates taillight converter.
HJ	Per Dodge owner's manual: If trailer is equipped with more than standard lighting (1 taillight per side) use of ModuLite® or dealer supplied harness is required.
JM	Some early production 1994 models may require #118348.
LS	T-One incorporates low-side switching taillight converter. Additional installation time required.
M	Will fit with heavy-duty suspension.
N	DO NOT cut or splice vehicle wiring. Only use approved T-One or see auto dealer for trailer tow wiring kit.
QP	Will not fit vehicles with backup sensors built into rear bumper.
RD	For vehicles equipped with factory tow package may require additional components or may be used as a replacement harness.
RW	On some models it may require an upgraded flasher or ModuLite®.
TR	Trimming or Modification of the vehicle connector may be required.
Z	May be equipped with Factory Tow Prep Plug. Determine at time of installation.

HITCH APPLICATION FOOTNOTES

#	Titan hitches require use of a 2-1/2" shank Titan ball mount.
@	Ultra Frame ball mount must be used to achieve maximum weight carrying rating.
†	Available while supply lasts.
AA	Requires temporary removal of bumper during installation.
AB	Requires four (4) 3/8" spacer blocks (#01077011) for installation. (Sold separately)
AE	Requires temporary removal of muffler during installation.
AF	Hitch is ONLY rated for Weight Carrying at 3500 lbs. GTW / 350 lbs. TW and DO NOT use Weight Distribution Spring Bars for this Specific Vehicle. Except for long bed pickups.
AI	Additional installation time may be required.
AL	Additional installation time required for vehicles equipped with load leveling compressor.
AW	Will not fit Turbo models.
BF	Requires standard bumper. Will not fit with step bumper.
BY	Minor repositioning of muffler required.
CA	Models with dual exhaust require exhaust modification.
CC	Requires minimum of 19" from end of frame rail to spring shackle bracket.
CN	Requires OEM factory bumper for hitch installation.
CO	Will not fit 8 ft. 2500/3500 Series with heavy-duty suspension or four door Crew Cab.
CP	Fits all models without factory installed receiver.
CQ	Will not fit with heavy duty suspension.
CR	Fits with mini spare tire stowed under vehicle. Will not fit with full size spare.
CS	Will fit with full-size spare tire stowed under vehicle.
CT	Will not fit long bed models after 1999.
DA	Will not fit with tube style bumper.
DB	Will not fit 6 ft. bed pickups.
DH	Cannot be installed on 1987-97 vehicles with factory step bumpers unless step bumper and its mounting brackets are permanently removed and standard factory bumper is installed.

RECEIVER HITCH APPLICATION GUIDE FOOTNOTES

HITCH APPLICATION FOOTNOTES (Continued)

DS	Use DT #75151 On 1500 Models Built After 11/1/02. Use DT #75135 On 1500 Models Built Before 11/1/02.
DU	Fascia removal required.
DY	Use On 1500 Models Built After 11/1/02.
EB	Factory electrical bracket will NOT fit with this hitch. Must use aftermarket electrical box or bracket.
EF	Fits all models with standard bumpers.
EG	Relocation of spare tire bracket is not required. NOTE: 19mm open end style wrench must be purchased to allow removal of spare tire after hitch installation.
EO	Requires longer ball mount.
EP	Fascia trimming may be required.
FE	Fascia trimming may be required. Allow additional installation time.
FP	Spare tire repositioning and/or modification of spare tire carrier may be required.
FS	Includes 2 & 4 WD models with heavy duty suspension.
GH	Will not fit models with 34" wide frames.
GO	Requires hitch with packaging date code 2/15/94 or later.
GP	Hitch crosstube concealed behind bumper.
GU	Will not fit vehicles with factory or aftermarket lower Fascia/Rollpan or Tube Bumper.
GX	Requires fabrication of "L" bracket to reposition exhaust on '95 and later 6 ft. box models.
HA	External dress panel beneath 95-97 and 03-05 vehicles must be removed for hitch installation.
HB	Slight fascia deformation may occur on some models.
HC	Will not fit with mini or full size tire stowed under vehicle.
HD	Will not fit 6 ft. bed pickups except 6 ft. Super Cab.
HK	Under vehicle spare tire stowage may be retained with installation of an aftermarket spare tire repositioner. Cutting of rollpan in license plate area required for receiver tube access. Does not fit with bumper.
HM	Hitch crosstube is visible beneath bumper.
HP	Requires four (4) 7/16" x 1" x 2" spacer blocks (#01080012) for installation. (Sold separately)
HR	Requires drilling of heat shields on V6 models.
HX	Minor exhaust modification may be required.
HY	Ultra Frame ball mount DT #4283/HH #80125 cannot be used in rise position on vehicles with step bumpers.
I	Hitch is positioned further rearward to accommodate spare tire.
J	Under vehicle spare tire stowage is retained.
JF	Will not fit with 16" spare tire.
JL	Installation requires OEM bumper and brackets.
JR	Exhaust must be temporarily lowered for installation.
JV	Rubber air deflector/fascia must be removed or trimmed to install hitch.
K	Adapter kit (#1685) required with DT #41504/HH #87480/RS #37081 & RS #44143 for 1980 and later F-Series pickups.
KA	Gasoline engine models only.
KH	Minor heat shield modification may be required.
KK	When installing on a vehicle originally equipped with an OEM hitch. OEM bumper brackets must be purchased and installed prior to new hitch installation.
KL	Hitch is designed to attach beneath the OEM hitch.
KM	Does not work with models originally equipped with OEM hitch.
L	Exhaust repositioning required.
LT	Requires removal of factory hitch if equipped.
M	Will fit with heavy-duty suspension.
MB	Will not fit models equipped with air suspension package.
QW	Will not fit vehicles with dual exhaust.
RA	Do not install on early 1996 models equipped with M10 fasteners.
RB	Hitch installation can be made easier with a "cutter" type drill bit.
RC	Will not fit with rear sport bars.
RH	Optional drawbar #36051 required (Sold separately) except for models with ZR2 & Highrider package.
RO	Will not fit Silverado SS.
SA	Requires drilling on 6 ft. bed models.
SB	Will not fit models with short bed.
SC	Minor trimming of plastic trunk pan required.
SD	Hitches produced before 07/21/06 are rated at 350/3500 WC.

RECEIVER HITCH APPLICATION GUIDE FOOTNOTES

HITCH APPLICATION FOOTNOTES (Continued)

SG	Hitches produced before 09/10/07 are rated at 1000/10000 WC & 1200/12000 WD.
SH	Hitches produced before 09/27/07 are rated at 1200/12000 WC & 1400/14000 WD.
SI	Hitches produced before 07/31/07 are rated at 350/3500 WC & 500/5000 WD.
SN	Hitches produced before 04/28/08 are rated at 1000/10000 WC & 1200/12000 WD.
SO	With this hitch installed the step bumper is no longer able to be used as a towing point.
SR	Only use ball mounts with 8-1/2" length : 3/4" rise : 2" drop for this vehicle.
ST	Will not fit 2WD models with short bed.
SU	Hitches produced before 03/11/08 are rated at 1000/10000 WC & 1200/12000 WD.
SV	Trimming or removal of under body appearance panel may be required.
SY	Hitch crosstube is visible beneath bumper with a more than normal gap between fascia and crosstube.
SZ	Hitches produced before 03/10/11 are rated at 600/6000 WC.
TA	Trunk access required for hitch installation.
TD	Hitches without electrical bracket are rated at 350/3500 WC & No WD. Hitch with electrical bracket rated at 400/4000 WC & No WD.
TE	Hitches produced before 04/20/11 are rated at 500/5000 WC.
TG	Hitches produced before 05/13/11 are rated at 350/3500 WC.
TI	Hitches produced before 06/06/11 are rated at 400/4000 WC.
TJ	Hitches produced before 07/13/11 are rated at 350/3500 WC.
TK	Hitches produced before 09/09/11 are rated at 500/5000 WC & 600/6000 WD.
TL	Hitches produced before 10/31/11 are rated at 500/5000 WC & 750/7500 WD.
TM	Hitches produced before 01/04/12 are rated at 500/5000 WC & 750/7500 WD.
TN	Hitches produced before 07/09/12 are rated at 500/5000 WC & 500/5000 WD.
TO	Will not fit models equipped Chassis Cab spring mount.
TQ	Hitches produced before 07/30/12 are rated at 350/3500 WC.
TU	Hitches produced before 07/24/12 are rated at 350/3500 WC.
TW	Receiver hitch may limit hands-free liftgate sensor range
TZ	Requires replacement of the impact structure with hitch.
UD	Fascia removal required on XR & XRS models.
UL	This hitch will not fit a Sprinter single or dual rear-wheel vehicle with a 30-3/8" wide frame measured outside of frame to outside of frame.
V	For vehicles with factory installed step bumpers only.
VB	Will not fit vehicles with vibration damper installed at rear of frame on drivers side.
X	Minor fascia trimming required.

DRAW-TITE® **THE BRAND OF CHOICE** **SINCE 1946**



HITCH ACCESSORIES

HITCH BALLS

Selecting the Right Hitch Ball.	3
Selecting the Right Ball Mount.	3
Hitch Balls.	4
Interchangeable Hitch Ball System.	5

BALL MOUNTS

Class I & II Drawbars.	7
Max Frame™ Mount Kits	8
Easy Load Ball Mounts	8
Utility Ball Mounts.	8
Packaged Angled Cut Ball Mounts.	8
Class III Ball Mounts.	9
Towing Start Kits	9
Solid Forged Ball Mounts.	10
Hallow & Solid Shank Ball Mounts.	11
Class V Ball Mounts.	11
Adjustable Ball Mounts.	11-12
Reversible Dual / Tri Ball Mounts.	13

HITCH ACCESSORIES

Bumper Guard.	14
Hitch Ball Wrench.	14
Reducer Bushing / Sleeves.	14
Receiver Adapters / Extensions.	14

PINTLE HOOKS AND ACCESSORIES

Pintle Hook Mounts.	15
Adjustable Pintle Mounts.	15
Pintle Hooks.	16
Lunette Rings.	16
Tow Eyelets / Hooks / Rings.	16
Clevis Mounts.	17
Replacement Parts.	17

PINS AND CLIPS

Swivel / Stabilizing Pins.	18
J-Pins.	18

ANTI-RATTLE

Lock-Tite™	19
QSP™ Hitch Silencing System.	19

LOCKS AND ACCESSORIES

Hitch / Trailer / Coupler Locks.	20-22
Combo Locks.	22
Tube Covers.	23-24

NEW PRODUCTS



63076

63075

ADJUSTABLE BALL MOUNT HEAD UNITS

- 2" square shank
- Adjustable ball mount head unit only



63069

ADJUSTABLE BALL MOUNT COMBO LOCK SET

- 5/8" lock for 2" square receiver
- 3/4" lock for adjustable head unit
- Keyed alike



1291020383

1291020340

ADJUSTABLE LUNETTE RINGS

- 3" diameter
- 14,000 lbs. capacity



63080

QSP™ HITCH SILENCING SYSTEM

- Fits 2" square receivers
- Quiet, secure performance

FEATURED PRODUCTS

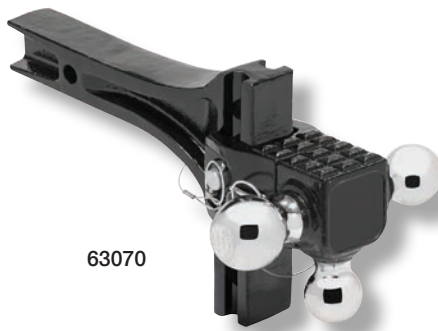

63070

ADJUSTABLE TRI-BALL MOUNT

- 2" square shank
- Rated up to 14,000 GTW



SOLID STEEL HITCH BALLS

- 1-7/8" - 2-5/16" diameters
- Rated up to 20,000 lbs. GTW
- Cold forged for superior strength

SELECTING THE RIGHT HITCH BALL

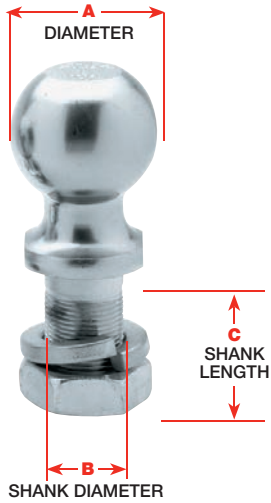

Selecting the right hitch ball is a must for trouble-free towing. Always use the properly rated hitch ball for your towing system.

- Your towing system's maximum weight rating is always equal to the lowest rated item in the system
- Your hitching system cannot be upgraded to a rating higher than the maximum rating of your hitch

For example, a 3,500 lbs. ball on a 2,000 lbs. max trailer weight-rated hitch does not increase your towing capacity to 3,500 lbs. Your hitching system is still rated at 2,000 lbs.

Conversely, a 2,000 lbs. ball on a 3,500 lbs. max trailer weight-rated hitch decreases your maximum towing capacity to 2,000 lbs.

The hitch ball diameter (A) must be the same diameter as the trailer coupler (1-7/8", 2", or 2-5/16").

The shank diameter (B) of the hitch ball should be the same as the hole diameter in the (correct) ball mount you selected.

The shank length (C) should be long enough to allow at least two threads to be visible when the hitch ball is installed and the nut completely tightened.

SELECTING THE RIGHT BALL MOUNT

LENGTH

Distance from the center of the ball hole to the center of the pin hole

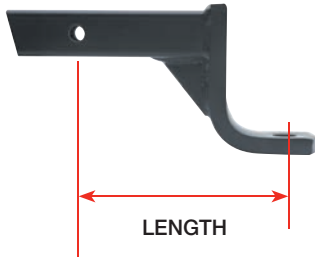

Tow vehicle and trailer level



For safe, comfortable towing, the trailer should always be set up to tow on a level plane.

Trailer not level



Sometimes a trailer's tongue is higher or lower than the ball mount on the vehicle, and a ball mount with a "rise" or a "drop" is required to level the trailer.

RISE

Distance from the top of the shank to the top of the ball platform



23"



18"

DROP

Distance from the top of the shank to the top of the ball platform



MEASURING FOR THE PROPER BALL MOUNT

1. Measure from the ground to the top of the hitch.
2. Measure from the ground to the (inside) top of the trailer coupler, when level.
3. Subtract the height of the hitch ball (most are 2-1/2" - 3" high) from coupler measurement.
4. An 8" drop is needed to make the trailer level.

THE DIFFERENCE IN THE TWO MEASUREMENTS IS THE AMOUNT OF BALL MOUNT "RISE" OR "DROP" REQUIRED.

HITCH BALLS



All hitch balls built with wrench flats

HITCH BALLS

- Solid steel hitch balls engineered to meet all safety requirements of VESC regulation V-5
- Cold forged for superior strength
- When installing hitch balls, torque all 3/4" shank dia. (B) balls to 160 ft. lbs., 1" shank dia. (B) balls to 250 ft. lbs., and 1-1/4" shank dia. (B) balls to 450 ft. lbs.



63840



028351



028351



HITCH BALLS

Shank Dia. B	Shank Length C	Drawbar Thickness Range	GTW GVWR Rating	Zinc Bulk	Zinc Ind. Packaged	Chrome Bulk	Chrome Ind. Packaged	Chrome 6 Pack Display	Stainless Ind. Packaged	Precision Machined
1-7/8" Ball Dia. - A										
3/4"	1-1/2"	3/8"-5/8"	2,000	63811	63881	63810	63880	63810-006		
3/4"	2-3/8"	3/8"-1-3/8"	2,000	63813		63812	63882			
3/4"	3-3/8"	3/8"-2-1/8"	2,000			63814				
1"	2-1/8"	3/8"-3/4"	2,000	63817	63885	63816	63884	63816-006	63851	
1"	3-3/8"	3/8"-2-1/8"	2,000	63819		63818				
2" Ball Dia. - A										
3/4"	1-1/2"	3/8"-5/8"	3,500	63821	63888	63820	63887			
3/4"	2-1/8"	3/8"-3/4"	3,000							028375
3/4"	2-3/8"	3/8"-1-3/8"	3,500	63823		63822	63889			
3/4"	3-3/8"	3/8"-2-1/8"	3,500			63824				
1"	2-1/8"	3/8"-3/4"	5,000							028351 ♦
1"	2-1/8"	3/8"-3/4"	6,000						63852	
1"	2-1/8"	3/8"-3/4"	7,000							028352
1"	2-1/8"	3/8"-3/4"	7,500	63848	63910	63845	63909	63845-006		
1"	3-1/4"	3/8"-2-1/8"	7,500	63850		63849				
1-1/4"	2-3/4"	3/8"-1"	8,000	63831		63830	63899			
2-5/16" Ball Dia. - A										
1"	2-1/8"	3/8"-3/4"	6,000						63853	
1"	2-1/8"	3/8"-3/4"	7,500	63846	63907	63847	63908	63847-006		
1-1/4"	2-3/4"	3/8"-1"	12,000	63835	63897	63834	63896			
1-1/4"	2-3/4"	3/8"-1"	12,500							028400 ♦
1-1/4"	2-3/4"	3/8"-1"	14,000			63836#				
1-1/4"	2-3/4"	3/8"-1"	20,000			63840#				
50mm (1,600 kg) Ball Dia. - A										
3/4"	1-1/2"	3/8"-5/8"	3,500			63912				

Hitch ball requires use with like rated receiver & ball mount. Consult tow vehicle owners manual for maximum towing capacities.

♦ DENOTES MOST POPULAR



58117

74342

HITCH BALL LUBE

Part No.	Description
58117	Hitch Ball Lube, 4 oz. jar

HITCH BALL WRENCH

Part No.	Description
74342	Hitch Ball Wrench, boxed end 1-1/8" & 1-1/2"



INTERCHANGEABLE HITCH BALL SETS

Designed to accommodate towing multiple trailers with ease, Draw-Tite Interchangeable Hitch Ball System allows you to change hitch ball sizes in seconds without any tools. Available in 2 and 3-ball sets, these kits feature a quick-release, positive-latch design. Available in 3/4" and 1" shank models.

- Innovative quick release changes balls in seconds
- Rated capacities up to 8,000 lbs.
- Durable heat treated shank
- New positive latch design
- No special tools required

Part No.	Shank	Ball A	Ball B	Ball C	Max GTW (lbs.)
63801	3/4"	1-7/8"	2"	—	5,000
63802	1"	1-7/8"	2"	—	8,000
63804	1"	—	2"	2-5/16"	8,000
63803	1"	1-7/8"	2"	2-5/16"	8,000



STEP 1: ATTACH SHANK

- Attach correct shank to drawbar or ball mount
- Torque to required tightness



STEP 2: ATTACH BALL

- Select the correct ball size for your trailer
- Place ball on shank



STEP 3: TIGHTEN LOCKING HEAD

- Innovative locking screw requires only 1/4 turn to secure
- No need for special tools



REPLACEMENT PARTS

Part No.	Description	Max GTW (lbs.)
63805	1-7/8" Interchangeable Hitch Ball Head	—
63806	2" Interchangeable Hitch Ball Head	—
63807*	2-5/16" Interchangeable Hitch Ball Head	—
63808	3/4" Interchangeable Hitch Ball Shank	5,000
63809	1" Interchangeable Hitch Ball Shank	8,000

* Only to be used with a 1" shank

HITCH & TRAILER ALIGNMENT TOOL

- Convenient one person hitch alignment system
- Magnetic base for fast and easy location
- Telescoping rods adjust up to 42"
- Easy to use the first time

Part No.	Description
63300	Hitch & Trailer Alignment Tool



DRAWBARS

We offer ball mounts and drawbars in three separate styles: straight cut, angle cut and drop cut. Refer to the styles below to select the mount that best suits your needs.

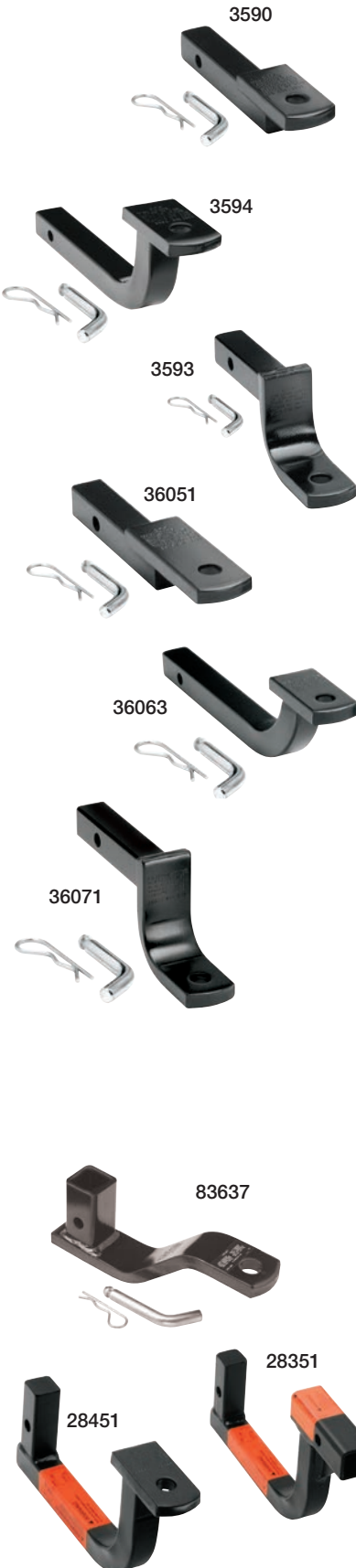

DRAWBAR TYPES

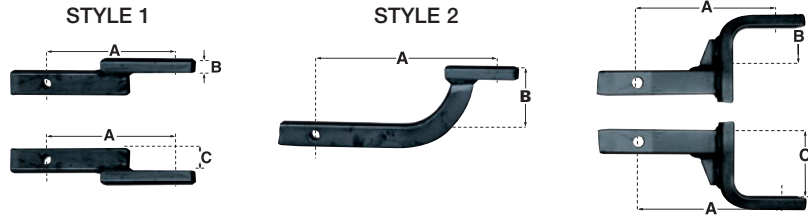

CLASS I DRAWBAR KITS

- Boxed includes drawbar, pin and clip
- Black powder coat finish over A-coat
- Fits 1-1/4" square receiver tube opening

Part No.	Rating (lbs.) GTW/TW	Ball Hole Size	A Length	B Rise	C Drop	Style
3590	2,000/200	3/4"	6-5/8"	5/8"	N/A	1
3591	2,000/200	3/4"	9-3/4"	5/8"	N/A	1
3592	2,000/200	3/4"	9-3/4"	2-1/8"	2-3/4"	3
3593	2,000/200	3/4"	6-5/8"	2-1/8"	2-3/4"	3
3594	2,000/200	3/4"	10"	4"	N/A	2

NOTE: Class I drawbar applications are specific. The correct replacement drawbar part number is listed on each Class I hitch installation instruction sheet.

CLASS II DRAWBAR KITS

- Boxed includes drawbar, pin and clip
- Black powder coat finish over A-coat
- Fits 1-1/4" square receiver tube opening

Part No.	Rating (lbs.) GTW/TW	Ball Hole Size	A Length	B Rise	C Drop	Style
36051	3,500/300	3/4"	7"	5/8"	1-1/4"	1
36053	3,500/300	3/4"	9-3/4"	5/8"	1-1/4"	1
36061	3,500/300	3/4"	9-3/4"	3-1/8"	N/A	2
36063	3,500/300	3/4"	11-3/4"	3-1/8"	N/A	2
36065	3,500/300	3/4"	10"	5"	N/A	2
36071	3,500/300	3/4"	7-3/16"	2-5/8"	3-1/4"	3
36078*	3,500/300	3/4"	7-3/8"	-	4-3/4"	3

* Fits 1-1/4" OEM Ford Explorer, Lincoln Aviator & Mercury Mountaineer hitch

NOTE: Class II drawbar applications are specific. The correct replacement drawbar part number is listed on each Class II hitch installation instruction sheet.

DRAWBAR OEM KITS

Part No.	Description
83637	Drawbar Kit for OEM Dodge Magnum hitch, 2,000 lbs. (includes pin and clip)

INVISI-HITCH™ ACCESSORIES

Part No.	Description
28451	Drawbar Kit, 2,000 lbs. (includes swivel pin)
28351	Accessory Adapter Kit (includes swivel pin)

SELECTING THE PROPER BALL MOUNT: BALL MOUNT MEASUREMENTS



LENGTH

Distance from the center of the ball hole to the center of the pin hole

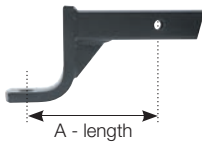

RISE

Distance from the top of the shank to the top of the ball platform



DROP

Distance from the top of the shank to the top of the ball platform

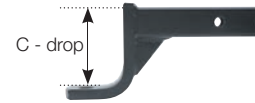

MAX FRAME MOUNT KITS – CLASS III/IV

- Fits 2" square receiver tube opening
- Includes pin and clip
- Black powder coat finish over A-coat

Part No.	Rating (lbs.) GTW/TW	Ball Hole Size	A Length	B Rise	C Drop	Style
2923	7,500/750	1"	8-1/2"	3/4"	2"	2
2953	7,500/750	1"	9"	2-3/4"	4"	3



**STYLE 2
ANGLE CUT**

EASY LOAD BALL MOUNTS

Featuring a revolutionary tapered shank design, easy-load ball mounts provide an easy connection to the receiver.

- Angle cut design
- Fits 2" square receiver tube opening
- Black powder coat finish over A-coat

Part No.	Bulk Part No.	Rating (lbs.) GTW/TW	Ball Hole Size	A Length	B Rise	C Drop	Style
40342	40342-006	7,500/750	1"	8-1/2"	3/4"	2"	2
40343	40343-006	6,000/600	1"	10-1/2"	3/4"	2"	2
40344	40344-006	7,500/750	1"	9"	2-3/4"	4"	2
40345	40345-006	6,000/600	1"	11"	2-3/4"	4"	2
40346	40346-002	6,000/600	1"	9-1/2"	4-3/4"	6"	2

Note: Pin and clip sold separately



**STYLE 3
DROP CUT**

UTILITY BALL MOUNTS

- Fits 2" square receiver tube opening
- Bulk boxed
- Black powder coat finish over A-coat

Part No.	Bulk Part No.	Rating (lbs.) GTW/TW	Ball Hole Size	A Length	B Rise	C Drop	Style
2736	2736-006	5,000/500	1"	12"	3/4"	2"	1
2793	2793-002	5,000/500	1"	10"	6-3/4"	8"	3
2706		5,000/500	1"	9"	-	11"	3
		3,500/350	1"	9"	9-3/4"	-	

Note: Pin and clip sold separately

PACKAGED ANGLED CUT BALL MOUNTS

- Fits 2" square receiver tube opening
- Includes pin and clip
- Black powder coat finish over A-coat



Part No.	Rating (lbs.) GTW/TW	Ball Hole Size	A Length	B Rise	C Drop	Style
40443	6,000/600	1"	10-1/2"	3/4"	2"	2
40446	6,000/600	1"	9-1/2"	4-3/4"	6"	2



40565

CLASS III INTERLOCK® TOWING STARTER KITS

- Includes 2" hitch ball
- Includes receiver lock
- Black powder coat finish over A-coat
- Fits 2" square receiver tube opening

Part No.	Rating (lbs.) GTW/TW	A Length	B Rise	C Drop	Secure
40565	6,000/600	8-1/2"	3/4"	2"	Lock

CLASS III STANDARD TOWING STARTER KITS (2-PACK)

- Point of purchase retail display
- Two kits per display box
- Fits 2" square receiver tube opening
- Includes pin and clip
- Black powder coat finish over A-coat
(except 40567-002 & 40584-002 w/Chrome Ball Mount)



40644-002



80644-002



83058-002

Part No.	Rating (lbs.) GTW/TW	A Length	B Drop	C Ball Size	Secure
40058-002	7,500/750	8-1/2"	2"	2-5/16"	Pin/Clip
40238-002	7,500/750	9"	4"	2-5/16"	Pin/Clip
40583-002	7,500/750	8-1/2"	2"	2"	Pin/Clip
40584-002	7,500/750	8-1/2"	2"	2"	Pin/Clip
40644-002	7,500/750	9"	4"	2"	Pin/Clip

Part No.	Rating (lbs.) GTW/TW	A Length	B Drop	C Ball Size	Secure
80058-002	7,500/750	8-1/2"	2"	2-5/16"	Pin/Clip
80472-002	7,500/750	9"	4"	2-5/16"	Pin/Clip
80583-002	7,500/750	8-1/2"	2"	2"	Pin/Clip
80644-002	7,500/750	9"	4"	2"	Pin/Clip

Part No.	Rating (lbs.) GTW/TW	A Length	B Drop	C Ball Size	Secure
83058-002	7,500/750	8-1/2"	2"	2-5/16"	Pin/Clip
83238-002	7,500/750	9"	4"	2-5/16"	Pin/Clip
83407-002	2,000/200	8-1/2"	2"	1-7/8"	Pin/Clip
83583-002	7,500/750	8-1/2"	2"	2"	Pin/Clip
83644-002	7,500/750	9"	4"	2"	Pin/Clip



SOLID FORGED BALL MOUNTS



- Solid one-piece forged construction
- 1" thick x 3" wide ball platforms
- Angled, easy-load design
- Black powder coat finish over A-coat
- Fits 2" square receiver tube opening

Part No.	Bulk Part No.	Rating (lbs.) GTW/TW	Ball Hole Size	A Length	B Rise	C Drop
40330	40330-002	16,000/2,400	1-1/4"	8-1/2"	1"	2"
40331	40331-002	16,000/2,400	1-1/4"	9-1/4"	3"	4"
40332	40332-002	16,000/2,400	1-1/4"	10-1/4"	5"	6"

ALUMINUM SOLID FORGED BALL MOUNTS



- Solid one-piece forged construction
- 1" thick x 3" wide ball platforms
- Aluminum finish
- Fits 2" square receiver tube opening

Part No.	Rating (lbs.) GTW/TW	Ball Hole Size	A Length	B Rise	C Drop
40381	8,000/800	1"	9-7/8"	1"	2"
40382	8,000/800	1"	10-5/8"	3"	4"
40383	8,000/800	1"	11-7/8"	5"	6"
40384	6,000/600	1"	10-7/8"	7"	8"

HOLLOW SHANK BALL MOUNTS



- Black powder coat finish over A-coat
- Fits 2" square receiver tube opening

Part No.	Rating (lbs.) GTW/TW	Ball Hole Size	A Length	B Rise	C Drop	Style
40200	10,000/1,000	1-1/4"	8-1/2"	3/4"	2"	1
40201	10,000/1,000	1-1/4"	9"	2-3/4"	4"	3
40202	10,000/1,000	1-1/4"	11-1/4"	2-3/4"	4"	3
40205	10,000/1,000	1-1/4"	9"	-	6"	3
40206	10,000/1,000	1-1/4"	9"	-	8"	3



SOLID SHANK BALL MOUNTS

- Fits 2" square receiver tube opening
- Durable zinc coated finish



Part No.	Rating (lbs.) GTW/TW	Ball Hole Size	A Length	B Rise	C Drop	Style
4280	12,000/1,200	1-1/4"	8-1/2"	1"	2"	1
4284	12,000/1,200	1-1/4"	12"	1"	2"	1
4281	12,000/1,200	1-1/4"	8-1/2"	3"	4"	3
4285	12,000/1,200	1-1/4"	12"	3"	4"	3
4282	12,000/1,200	1-1/4"	9-1/2"	5"	6"	3
4283	12,000/1,200	1-1/4"	9-1/2"	7"	8"	3

CLASS V BALL MOUNTS

- Fits 2-1/2" square receiver tube opening
- Black powder coat finish over A-coat



Part No.	Rating (lbs.) GTW/TW	Ball Hole Size	A Length	B Rise	C Drop	Style
45122	14,000/1,400	1-1/4"	9-3/4"	1-1/2"	3"	3
45123	13,000/1,300	1-1/4"	10"	3-1/2"	5"	3
45291	13,000/1,300	1-1/4"	10-1/2"	-	7-3/4"	3
45322	18,000/2,000	1-1/4"	10"	1-1/2"	3"	3
45323	18,000/2,000	1-1/4"	10"	3-1/2"	5"	3

ADJUSTABLE HOLLOW SHANK BALL MOUNT

- Fits 2" Receiver Rated at 6,000 lbs. GTW/600 lbs. TW
- Quick release pin and clip for maximum adjustability
- Black powder coat finish over A-coat



Part No.	Description	Length	Max. Rise	Max. Drop
6580	Complete Shank and Head Assembly with quick release pin and clip	12"	6-1/8"	7-3/8"

HOLLOW SHANK BALL MOUNT WITH SWAY CONTROL TAB

- Rated at 6,000 lbs. GTW/600 lbs. TW
- Platform mounts for left or right hand sway control



Part No.	Description	Length	Max. Rise	Max. Drop
7390	Complete Shank and Head Assembly	12"	3-3/4"	5-1/4"

NOTE: Hitch ball, pin (55010) and clip (55515) sold separately. Not interchangeable with weight distribution replacement parts.

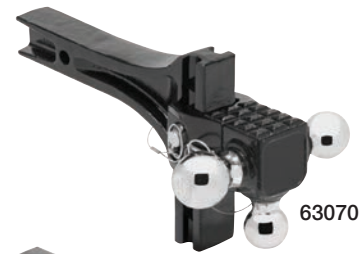

63070



63071



63911

ADJUSTABLE BALL MOUNTS

The Adjustable Mount only takes a pull of the pin and a turn to get ready for towing with the most common hitch ball sizes. Just like you, it's always ready to get the job done. Height adjusts easily and the easy-to-use pin is secured by a lanyard so you can't lose it.

- Fits 2" receivers, rated up to 14,000 lbs. GTW
- Adjust height up to 10.5"
- Adjustable cast shank, knurled bolt pin with secure lanyard
- Black powder coat finish resists corrosion

Part No.	Description	Length	Max. Rise	Max. Drop
63070	Adjustable Tri-Ball Ball Mount System w/Step, 2" Sq. Shank, 1-7/8" Ball 2,000 lbs (GTW), 2" Ball 10,000 lbs. (GTW), 2-5/16" Ball 14,000 lbs. (GTW)	11-9/16"	5-11/16"	4-3/4"
63071	Adjustable Dual Ball Mount System, 2" Sq. Shank, 2" Ball 10,000 lbs. (GTW), 2-5/16" Ball 14,000 lbs. (GTW)	12"	4-5/8"	5-7/8"

REPLACEMENT PARTS

Part No.	Description
63911	Replacement Cast Shank

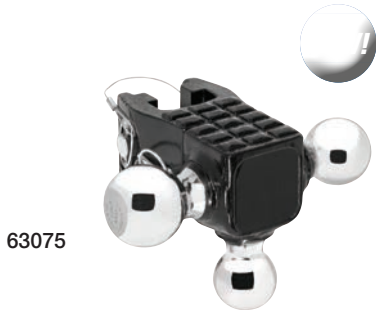

63075



63076

ADJUSTABLE BALL MOUNTS HEAD UNITS

- Adjustable Dual Ball Mount System Head Unit Only
- Adjustable height - Perfect for towing multiple trailers of varying heights and couplers
- Knurled bolt pins with secure lanyard included
- Black powder coat finish

Part No.	Description
63075	Adjustable Tri-Ball Mount System Head Unit Only - 1-7/8" (2K rating), 2" (10K GTW), and 2-5/16" (14K GTW) Hitch balls
63076	Adjustable Dual Ball Mount System Head Unit Only - 2" (10K GTW), and 2-5/16" (14K GTW) Hitch balls



63069

ADJUSTABLE BALL MOUNT COMBO LOCK SET

- 5/8" lock for 2" square receivers
- 3/4" lock for adjustable ball mount head unit
- Keyed alike

Part No.	Description
63069	Combo Lock Set, 5/8" for 2" Square Receivers and 3/4" for Accessory (Keyed Alike)

REVERSIBLE BALL MOUNTS

Reversible ball mounts are perfect for those who tow multiple trailer with varying ball diameters. Weight rating as per ball being used.



38180

CLASS V DUAL-BALL MOUNT

- Fits 3" square receiver tube opening.
- Includes 2" (17,000 lbs.) & 2-5/16" (25,000 lbs.) hitch balls
- 9" Length

Part No.	Description
38180	Dual-Ball Mount (2" & 2-5/16")



45325

CLASS V TRI-BALL HOLLOW SHANK

- Fits 2-1/2" square receiver tube opening.

Part No.	Description	Rating (lbs.) GTW/TW	Shank Length	Ball Size
45325	Tri-Ball Mount, Black Balls	2,000/200	8-3/4"	1-7/8"
		10,000/1,000	8-3/4"	2"
		14,000/1,400	7-1/2"	2-5/16"



80797
80798

80795
80796

DUAL-BALL / TRI-BALL SOLID SHANK

- Fits 2" square receiver tube opening

Part No.	Description	Rating (lbs.) GTW/TW	Shank Length	Ball Size
80795	Dual-Ball Mount, Black Balls, Black Solid Shank	2,000/200	8"	1-7/8"
		10,000/1,000	8"	2"
80796	Dual-Ball Mount, Black Balls, Black Solid Shank	10,000/1,000	8"	2"
		16,000/1,600	8"	2-5/16"
80797	Dual-Ball Mount, Chrome Balls, Black Solid Shank	2,000/200	8"	1-7/8"
		10,000/1,000	8"	2"
80798	Dual-Ball Mount, Chrome Balls, Black Solid Shank	10,000/1,000	8"	2"
		16,000/1,600	8"	2-5/16"
80791	Tri-Ball Mount, Black Balls, Black Solid Shank	2,000/200	8"	1-7/8"
		10,000/1,000	8"	2"
		16,000/1,600	6-3/4"	2-5/16"
80799	Tri-Ball Mount, Chrome Balls, Black Solid Shank	2,000/200	8"	1-7/8"
		10,000/1,000	8"	2"
		16,000/1,600	6-3/4"	2-5/16"



80791

80791



80404
80406

DUAL-BALL HOLLOW SHANK

- Fits 2" square receiver tube opening

Part No.	Description	Rating (lbs.) GTW/TW	Ball Size	Position
80404	Dual-Ball Mount, Black Hollow Shank	2,000/200	1-7/8"	Rise
		6,000/600	2"	Drop
80406	Dual-Ball Mount, Black Hollow Shank	6,000/600	2"	Drop
		6,000/600	2-5/16"	Rise



80425

80426

TRI-BALL HOLLOW SHANK

- Fits 2" square receiver tube opening

Part No.	Description	Rating (lbs.) GTW/TW	Shank Length	Ball Size
80425	Tri-Ball Mount, Black Balls, Black Hollow Shank	2,000/200	8"	1-7/8"
		6,000/600	8"	2"
		10,000/1,000	6-3/4"	2-5/16"
80426	Tri-Ball Mount, Chrome Balls, Black Hollow Shank	2,000/200	8"	1-7/8"
		6,000/600	8"	2"
		10,000/1,000	6-3/4"	2-5/16"



80400



80470



74342

58109

58184

80100

80106



38735



58102



58431



80300



80301



80303



80304

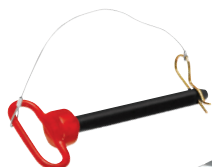

58388



45292



80306



11003

BUMPER GUARD, "THE HITCH GUIDE-AND-STOP"

- Protects vehicle from coupler impact while backing up

Part No.	Description
80400	Bumper Guard, black, mounts to any ball mount with 1" hole
80470	Bumper Guard, diamond plate, mounts to any ball mount with 1" hole

HITCH BALL WRENCH

Part No.	Description
74342	Hitch Ball Wrench, boxed end 1-1/8" & 1-1/2"

REDUCER BUSHING

- Allows 3/4" or 1" shank hitch balls, used in ball mounts w/1" or 1-1/4" holes

Part No.	Description	Packaging
58109	Reducer Bushing, 1" hitch ball shank hole to 3/4"	Reese
58184	Reducer Bushing, 1-1/4" hitch ball shank hole to 1"	Reese
80100	Reducer Bushing, 1" hitch ball shank hole to 3/4"	Hidden Hitch
80106	Reducer Bushing, 1-1/4" hitch ball shank hole to 1"	Hidden Hitch

REDUCER SLEEVE

- Reduces 3" or 2-1/2" square receiver tube opening to 2"

Part No.	Description
58431	Reducer Bushing w/Collar, 2-1/2" square receiver tube opening to 2"
58102	Reducer Sleeve, 2-1/2" square receiver tube opening to 2"
38735	Reducer Sleeve, 3" square receiver tube opening to 2"

RECEIVER ADAPTERS

- Designed to extend the receiver opening from 6" to 18", ideal for cargo carriers & bike carriers
- Use of this adapter reduces hitches' tow rating by 50% & with a maximum rating of 3,500 lbs towing capacity

Part No.	Description
80300	Adapts 2" to 1-1/4", 7" long, 3,500 lbs.
80301	Adapts 2" to 1-1/4", 14" long, 3,500 lbs.
80303	Adapts 1-1/4" to 2", 6" long, for Class II only; 3,500 lbs.
80304	Adapts 1-1/4" to 2", 10" long, for Class II only; 3,500 lbs.
58388	Class V Hitch Pin & Clip for 3" Square Receiver, 3/4"

RECEIVER EXTENSIONS

- Ideal for slide-out campers with extended overhangs
- Designed to extend the receiver opening 14", 18", 24", 34", 41" or 48"
- 2" square tube opening for use with ball mounts and hitch-mounted accessories
- Integrated electrical bracket attached (45292, 45018 only)

Part No.	Description	WC (lbs.)	WD (lbs.)	Length
80307	Receiver Extension	3,500	-	8"
80305	Receiver Extension	3,500	-	14"
80306	Receiver Extension	3,500	-	18"
11003	Receiver Extension	4,000	6,500	14"
11004	Receiver Extension	4,000	6,500	18"
11006	Receiver Extension with Step	4,000	6,500	18"
45292	Receiver Extension (For 2-1/2" receivers)	6,000 4,500	8,000 6,000	24" 34"
45018	Receiver Extension (For 2-1/2" receivers)	5,000 4,000	7,500 6,000	41" 48"
58388	Class V Hitch Pin & Clip for 3" Square Receiver, 3/4"			

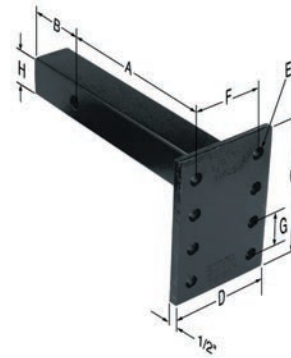

PINTLE HOOK MOUNTS

- Converts receivers for use with pintle-type trailers, quickly and easily
- Provides mounting for both ball and pintle and rigid type pintle hooks
- Pin and clip must be ordered separately

Part No.	Shank	Rating (lbs.) GTW/TW	A Shank	B Length	H Shank Dia.	C Height	D Width	E Hole	F Width	G Height	Hole Sets
63056	Hollow	6,000/600	7-5/8"	3"	2"	5-1/2"	5"	17/32"	3-3/8"	1-3/4"	3
63057	Solid	12,000/1,200	7-5/8"	3-1/4"	2"	7-1/2"	5"	17/32"	3-3/8"	1-3/4"	4
63058	Solid	8,000/800	11-3/8"	3-1/4"	2"	12-1/2"	5"	17/32"	3-3/8"	1-3/4"	7
63059	Solid	12,000/1,200	11-3/8"	3-1/4"	2"	7-1/2"	5"	17/32"	3-3/8"	1-3/4"	4
45156	Hollow	12,000/1,200	7-3/4"	3-1/4"	2-1/2"	6"	5"	17/32"	3-3/8"	1-3/4"	3
45294	Forged	18,000/2,000	8-1/2"	3-1/4"	2-1/2"	7-1/4"	5"	17/32"	3-3/8"	1-3/4"	4
38186	Forged	25,000/4,000	9"	3-1/4"	3"	9"	5"	17/32"	3-3/8"	1-3/4"	5



ADJUSTABLE PINTLE MOUNT

Tackle rough terrain with the toughest mount in town. Set it right where you want it for trailers of various heights and couplers. It converts quickly for a day of hassle-free towing.

- Fits 2" receivers, rated up to 14,000 lbs. GTW
- Adjust height up to 10.5"
- Adjustable cast shank, knurled bolt pin with secure lanyard
- Black powder coat finish resists corrosion



Part No.	Description	Length	Max. Rise	Max. Drop
63072	Adjustable Pintle Mount, 14,000 lbs. (GTW)	9-5/8"	4-1/4"	6-1/4"

REPLACEMENT PARTS

Part No.	Description
63911	Replacement cast shank



63013
63014
63015
63016

PINTLE HOOKS

Part No.	Description
63013	5 Ton, 2,000 lbs. max. vertical load, 10,000 lbs. GTW, with Mounting Hardware
63014	10 Ton, 4,000 lbs. max. vertical load, 20,000 lbs. GTW, with Mounting Hardware
63015	15 Ton, 6,000 lbs. max. vertical load, 30,000 lbs. GTW, with Mounting Hardware
63016	30 Ton, 14,000 lbs. max. vertical load, 60,000 lbs. GTW, with Mounting Hardware
63032	Replacement Hardware Mounting Kit



63010
63011
63012

PINTLE HOOK COMBINATION HITCHES

- 3,000 lbs. max. vertical load, 16,000 lbs. max. GTW when used as pintle hook

Part No.	Description
63010	1-7/8" Combo Hitch, 16,000 lbs. GTW, ball rating 6,000 lbs., with Mounting Hardware
63011	2" Combo Hitch, 16,000 lbs. GTW, ball rating 10,000 lbs., with Mounting Hardware
63012	2-5/16" Combo Hitch, 16,000 lbs. GTW, ball rating 14,000 lbs., with Mounting Hardware
63032	Replacement Hardware Mounting Kit



63023

63022



63036
63060

LUNETTE RINGS

Part No.	Description
63023	Lunette Ring, 2-1/2" dia., 4 hole base 42,000 lbs. GTW, 8,400 lbs. max. vertical load
63033	Hardware Mounting Kit for 63023
63022	Lunette Ring, 2-1/2" dia., 1-1/2" shank 15,000 lbs. GTW, 2,400 lbs. max. vertical load
63036	Adjustable Lunette Ring with Channel, 3" Dia., 24,000 lbs. Capacity
63060	Adjustable Lunette Ring with Hardware, 3" Dia., 24,000 lbs. Capacity (Adjustable Channels P/N AC300 0300, P/N AC500 0300 & Hardware Kit P/N 024202 sold separately, see pages J-39 & J-40)



1291020340

1291020383

LUNETTE RINGS

Part No.	Description
1291020383	Adjustable Lunette Ring, 3" dia. 14,000 lbs. Capacity, Bulk (Adjustable Channels P/N AC300 0300, P/N AC500 0300 & Hardware Kit P/N 024202 sold separately, see pages J-39 & J-40)
1291020340	Adjustable Lunette Ring, 3" dia. 14,000 lbs. Capacity, Clear Zinc, Bulk (Adjustable Channels P/N AC300 0300, P/N AC500 0300 & Hardware Kit P/N 024202 sold separately, see pages J-39 & J-40)



63043



63041



63045



63044

63047



63046



5761/5762

80410

5763/5764

RECEIVER ACCESSORIES

- Fits 2" square receiver tube opening

ONE-PIECE PINTLE HOOK

Part No.	Description	Max GTW	Ball GTW	Max VL
63043	5-Ton Receiver Mount Pintle Hook	10,000	-	2,000

ONE-PIECE PINTLE COMBINATIONS

Part No.	Description	Max GTW	Ball GTW	Max VL
63040	1-7/8" Receiver Mount Pintle Combination	12,000	2,000	2,400
63041	2" Receiver Mount Pintle Combination	12,000	7,000	2,400
63042	2-5/16" Receiver Mount Pintle Combination	12,000	12,000	2,400

RECEIVER MOUNT TOW EYELET

Part No.	Description
63045	Forged Receiver Mount Tow Eyelet, 10,000 lbs. GTW, 7-3/8" Length

RECEIVER MOUNT TOW HOOKS

Part No.	Description
63044	Forged Receiver Mount Tow Hook, 10,000 lbs. GTW, 7-3/8" Length
63047	Receiver Mount Tow Hook, 8,000 lbs. GTW, 7" Length

RECEIVER MOUNT TOW RING

Part No.	Description
63046	Receiver Mount Tow Ring, 8,000 lbs. GTW, 7-3/8" Length

CLEVIS MOUNTS

- For use with industrial/agricultural equipment

Part No.	Description	Ball Mount GTW/TW (lbs.)	Clevis Mount GTW/TW (lbs.)	Length
5761	Clevis Mount, 3/4" hole	3,500/350	5,000/350	9-3/4"
5762	Clevis Mount, 1" hole	6,000/600	6,000/600	8-7/8"
80410*	Clevis Mount, 1" hole	6,000/600	6,000/600	11"
6201	Clevis Mount, 1" hole	6,000/600	10,000/1,000	8-7/8"
5763	Clevis Pin, 3/4" dia.			4-1/4"
5764	Clevis Pin, 1" dia.			4-3/4"

* Ball Mount has 1-1/4" drop, Clevis has 3" drop

PINTLE HOOK REPLACEMENT PARTS

Part No.	Description
63050	1-7/8" Replacement Ball, 6,000 lbs., 1-1/8" diameter
63051	2" Replacement Ball, 10,000 lbs., 1-1/8" diameter
63052	2-5/16" Replacement Ball, 14,000 lbs., 1-1/8" diameter
63020	Replacement Snapper Pin, 1/4"
63032	Replacement Hardware Mounting Kit, Plate Mounted Pintle Hooks/Combination Hitches
63017	1-7/8" Replacement Ball, 6,000 lbs., 1-1/4" diameter
63018	2" Replacement Ball, 10,000 lbs., 1-1/4" diameter
63019	2-5/16" Replacement Ball, 14,000 lbs., 1-1/4" diameter

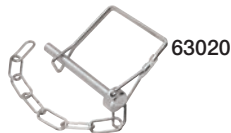

63020



63017

63018

63019

63050

63051

63052



63032



PINS AND CLIPS



Pins and clips are included with all Class I and II hitches.

Part No.	Description	Packaging
63241	Packaged Class I/II Pin & Clip, 1/2", groove style	Plastic Shroud
63241-050	Class I/II Pin & Clip, 1/2", groove style (50 pack)	Bulk
63240	Packaged Class III/IV Pin & Clip, 5/8", groove style	Plastic Shroud
63240-050	Class III/IV Pin & Clip, 5/8", groove style (50 pack)	Bulk
63242	Packaged Class III/IV Pin & Clip, 5/8", hole style	Plastic Shroud
63242-050	Class III/IV Pin & Clip, 5/8", hole style (50 pack)	Bulk
63242-100	Class III/IV Pin & Clip, 5/8", hole style (100 pack)	Bulk
63242-500	Class III/IV Pin & Clip, 5/8", hole style (500 pack)	Bulk
63243	Packaged Class V Pin & Clip, 5/8", groove style	Plastic Shroud
06237	Class I/II Bulk Pin, 1/2", groove style	Bulk
55010	Class III/IV Bulk Pin, 5/8", groove style	Bulk
55010-050	Class III/IV Bulk Pin, 5/8", groove style (50 pack)	Bulk
55515	Bulk Clip	Bulk
55515-050	Bulk Clip (50 pack)	Bulk
58388	Class V Hitch Pin & Clip for 3" Square Receiver, 3/4"	Bagged

SWIVEL PINS (PACKAGED)

Part No.	Description	Packaging
63202	1/2" Integral Pin and Clip, stainless	Clam
63203	5/8" Integral Pin and Clip, stainless	Clam
63204	1/2" Integral Pin and Clip, zinc	Clam
63205	5/8" Integral Pin and Clip, zinc	Clam

STABILIZING PIN WITH LOCK

More than just a hitch pin, J-Pin quickly and confidently secures ball mounts and other hitch-mounted accessories, eliminating the sway and rattle caused by part clearance issues.

J-Pin ready receiver design allows for the most confident and secure hookup in today's towing market by compressing the hitch-mounted accessory against the inner side wall of the hitch receiver tube. Once attached, the hitch and towing components seem virtually welded together.

Packaged complete with its integral ball mount lock, J-Pin makes your towing system complete.

J-PIN



- For 2" receivers only
- Ideal for bike racks and hitch-mounted cargo carriers
- Attachment wrench included
- Attractive point-of-purchase packaging
- Requires hitch with additional 17/32" hole in receiver tube
- Convenient 1/4" turn key for ease of use

Part No.	Description	Packaging
63201	J-Pin Anti-Rattle Pin w/Barrel Lockset	Clam



Insert J-Pin through large hole in receiver hitch



Tighten nut on J-Pin shaft, compressing ball mount or hitch-mounted accessory against receiver tube

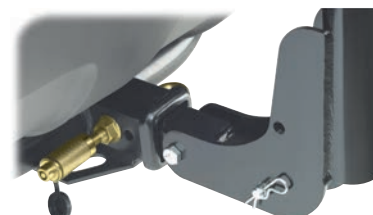

Secure ball mount or hitch-mounted accessory with locking head



63100

LOCK-TITE™ ANTI-RATTLE PIN

- Anti-Rattle device for cargo accessories, ball mounts, and more
- Handy insertion tool included
- Fits 2" receivers
- Keyed lock and wrench included
- Pro Series branded clamshell packaging with instructions on back of card
- Patent Pending

Part No.	Description	Packaging
63100	Lock-Tite™ Anti-Rattle Pin w/Lock & Wrench, 5/8" for 2" Sq. Receivers	Clam
63100-025	Lock-Tite™ Anti-Rattle Pin w/Lock & Wrench, 5/8" for 2" Sq. Receivers (25 pack)	Clam



63091

ANTI-RATTLE DEVICE

- Used to significantly reduce rattling noise and movement of accessories that are inserted into a receiver style hitch (e.g. Ball Mounts, Bike Racks, Ski Racks, Cargo Racks, etc.)
- Steel Constructed
- A-Coat Base w/ Black Powder Coat Finish
- Hitch Pin Not Included

Part No.	Description	Packaging
63090	Anti-Rattle Device for 1-1/4" Sq. Receivers (Class I & II Receivers)	Bagged
63091	Anti-Rattle Device for 2" Sq. Receivers (Class III/IV Receivers)	Bagged



63080

QSP™ HITCH SILENCING SYSTEM

- Designed to work with most Horizon Global, Class III 2" receivers (will not fit Ultra Frame models)
- Helps to tighten fit connection between receiver and accessory
- Reduces amount of sway in attached bike racks and cargo carriers
- High strength, aluminum construction collar and Cam arm
- Magnetic, poly cover helps protect receiver from weather and free of debris
- Easy to install

Part No.	Description
63080	QSP™ Hitch Silencing System for 2" Sq. Receivers
63082	QSP™ Hitch Silencing System for 2" Sq. Receivers





BULLDOG™ LIFELONG® LOCKS DELIVER TRIPLE SECURITY

- Stronger Break Resistance
- Dual Self-locking Design
- High Security Square Key Design
- Includes Dust Cap



580400



580401



580402



580403



580404



580405



580406



580407



580408



580409



580410

LIFELONG® HITCH LOCKS WITH 5/8" DIAMETER

Part No.	Description
580400	Chrome Bent Shank Lock for Class III & IV
580401	Chrome Dogbone Lock for Class III & IV
580402	Stainless Steel Dogbone Lock for Class III & IV

LIFELONG® TRAILER LOCK

Part No.	Description
580403	Chrome Coupler Lock

LIFELONG® COMBO LOCK

Part No.	Description
580404	Chrome Combo Lock Set, 5/8" Dogbone Receiver and Coupler, for Class III & IV

BULLDOG™ LOCKS

- Includes Dust Cap
- Easy Access Models Feature Side Key Entry, Sliding Dust Cap, Lock Housing Rotates 360°

HITCH LOCKS WITH 5/8" AND 1/2" DIAMETER

Part No.	Description
580405	Stainless Steel Dogbone Lock w/Sleeve for 1-1/4" & 2" Square Receivers
580406	Stainless Steel Combo Lock Set, 5/8" Dogbone Lock w/Sleeve for 1-1/4" & 2" Square Receivers and Coupler
580407	Easy Access Lock w/Sleeve for 1-1/4" & 2" Square Receivers

TRAILER LOCKS

Part No.	Description
580408	Stainless Steel Coupler Lock
580409	Easy Access Long Coupler Lock
580410	Easy Access Adjustable Coupler Lock
TK100 0100	Trailer Keeper® Lock - Heavy-duty, hardened steel construction. Adjustable to fit most trailer wheels up to 15". Includes brass lock and key set.



TK100 0100



63234

HITCH LOCKS WITH 5/8" AND 1/2" DIAMETER

Part No.	Description
63234†*	Dogbone Lock w/Sleeve for 1-1/4", 2" & 2-1/2" Square Receivers
63248	Bent Pin Lock w/Extra Pin for 1-1/4" & 2" Square Receivers

* not compatible with 18K Receivers



63224

HITCH LOCKS WITH 1/2" DIAMETER

Part No.	Description
63224	Bent Pin Lock for 1-1/4" Square Receivers



63223

HITCH LOCKS WITH 5/8" DIAMETER

Part No.	Description
63223	Bent Pin Lock for 2" & 2-1/2" Square Receivers
63252	Dogbone Lock for 2-1/2" Square Receivers, 3-1/2" Span, Class V
63253	Bent Pin Lock for 2-1/2" Square Receivers, 3-1/2" Span, Class V



63252

RECEIVER LOCK

Part No.	Description
580412	Receiver Lock, Dogbone Style, 5/8" for 2-1/2" Sq. Class V Receivers



CLK15 0100

CABLE LOCKS

Part No.	Description
CLK15 0100	Cable Lock w/Key, 15'
63233	Cable Lock, 5/16" x 10' Length
63255	Cable Lock, 5/16" x 4' Length

† = Available while supplies last.



63216KA



TRAILER LOCKS



Part No.	Description
63225	Coupler Lock
63226	Universal Coupler Lock
63227	Coupler Lock for 2-5/16" Ball
63228	Coupler Lock for 2" Ball

KEYED ALIKE COUPLER AND HITCH LOCKS

- Avoid the complication of having to keep track of different keys for every lock
- Includes 2 keys
- Order in multiples of 3 / minimum order is 3 locks

Part No.	Description
63216KA	KEYED ALIKE 1/2" Receiver Lock for Class II Receiver Hitches
63217KA	KEYED ALIKE 5/8" Receiver Lock for Class III & IV Receiver Hitches
63218KA	KEYED ALIKE Class II 1/2" Receiver Lock and 1/2" Span Style Coupler Lock
63219KA	KEYED ALIKE Class III & IV 5/8" Receiver Lock and 1/2" Span Style Coupler Lock
63220KA	KEYED ALIKE 1/2" Span Style Coupler Lock
63221KA	KEYED ALIKE 2" Span Style Coupler Lock with 1/4" Pin
63222KA	KEYED ALIKE 2-1/2" Span Style Coupler Lock with 1/4" Pin

COMBO LOCKS (HITCH, 5/8" & 1/2" DIA., AND TRAILER)

Part No.	Description
63249†	Combo Lock Set, Bent Pin/Brass Coupler, for 1-1/4" & 2" Square Receivers
63250	Combo Lock Set, Dogbone Receiver/Coupler, for 1-1/4" & 2" Square Receivers

ADJUSTABLE BALL MOUNT COMBO LOCK SET

- 5/8" lock for 2" square receivers
- 3/4" lock for adjustable ball mount head unit
- Keyed alike

Part No.	Description
63069	Combo Lock Set, 5/8" for 2" Square Receivers and 3/4" for Accessory (Keyed Alike)

KEYED ALIKE COUPLER/TRAILER/RECEIVER LOCK SET

- Guards against towed and parked trailer thefts
- Universal Coupler Lock Fits 1 7/8", 2", 2 5/16"
- Dual Bent Pin Lock: 1/2", 5/8"
- Adjustable Coupler Lock: 5/8", 1"
- 3 Interchangeable Keys

Part No.	Description
63256	Tow & Store™ KEYED ALIKE Universal Coupler Lock, Trailer Lock, Receiver Lock, Lock Set

† = Available while supplies last.



80037

RUBBER RECEIVER TUBE COVERS W/"HIDDEN HITCH" LOGO

Part No.	Description
60037	Class I/II Cover, rubber 1-1/4" Sq. with Header Card
60037-024	Class I/II Cover, rubber 1-1/4" Sq. (24 pack)
80037	Class III Cover, rubber 2" Sq. with Header Card
80037-012	Class III Cover, rubber 2" Sq. (12 pack)



5351
5352

1944

CHROME RECEIVER TUBE COVERS

Part No.	Description
5351	Receiver Tube Cover, 1-1/4" Sq., Chrome, Metal
5352	Receiver Tube Cover, 2" Sq., Chrome, Metal
1944	Receiver Tube Cover, 2" Sq., Chrome, Plastic

1202
5363
58070



RECEIVER TUBE COVERS

Part No.	Description
58070	Receiver Tube Cover, 1-1/4" Sq., Black, Nylon (24 pack)
1202	Receiver Tube Cover, 2" Sq., Black
01202-024	Receiver Tube Cover, 2" Sq., Black (24 pack)
5363	Receiver Tube Cover, 2" Sq., Black, Plastic (1202 with Header Card)



2211

RUBBER RECEIVER TUBE COVERS W/"D" LOGO

Part No.	Description
5362	Rubber Receiver Tube Cover, 1-1/4" Sq. w/"D" logo with Header Card
2211	Rubber Receiver Tube Cover, 1-1/4" Sq. w/"D" logo (bulk)
7050	Rubber Receiver Tube Cover, 2" Sq. w/"D" logo with Header Card
7010	Rubber Receiver Tube Cover, 2" Sq. w/"D" logo (bulk)
07010-024	Rubber Receiver Tube Cover, 2" Sq. w/"D" logo (24-pack)

"HITCH HIDER" RUBBER TUBE COVER

- Securely attaches to any 2" receiver tube
- Rubber construction tightly seals tube opening
- Built-in 4-way flat electrical cover



5330

Part No.	Description
5330	Class III Cover, black rubber
05330-010	Class III Cover, black rubber (10 pack)

80953



PLASTIC COVERS

- Provides custom finish
- Impact resistant construction

Part No.	Description
80953	Class III Cover, plastic

6431



6432



LOGO RECEIVER TUBE COVERS

- Attractive point-of-purchase packaging
- Foam gasket included for exact fit
- Heavy chrome face features popular OEM manufacturer logos
- OEM licensed

Part No.	Description
6431	Chevrolet logo, fits all 2" receivers
6432	Dodge Ram logo, fits all 2" receivers
6433	Ford oval logo, fits all 2" receivers

6433



74099



RECEIVER TUBE COVERS W/"REESE" LOGO

Part No.	Description
74099	Receiver Tube Cover, 2" Sq., w/"Reese" logo
74547	Receiver Tube Cover, 2" Sq., w/"Reese" logo
45144	Receiver Tube Cover, 2-1/2" Sq., W/"Reese" logo



74547



45144

BRAKE LIGHT COVER

- This handy cover doubles as an additional brake light.
- It plugs into a 4-way flat connector and lights up with turn and brake functions.

Part No.	Description
80980	Brake Light Cover, Class III

80980

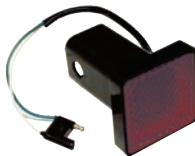

HITCH BALL COVER

Part No.	Description
42250	Hitch Ball Cover 1-7/8" - 2"
42250-012	Hitch Ball Cover Display Pack 1-7/8" - 2" (12 pack)
42251	Hitch Ball Cover 2-5/16"
42251-012	Hitch Ball Cover Display Pack 2-5/16" (12 pack)



42250

TEKONSHA® THE LEADER IN ELECTRICAL WIRING



ELECTRICAL WIRING & ACCESSORIES

ELECTRICAL SELECTION

Electrical Selection Chart.....3-4

T-ONE® CONNECTORS

T-One® Connectors.....5-6

MODULITE® POWER MODULES / CONVERTERS

ModuLite® Power Modules.....7-12

ModuLite® ZCI™.....9

Taillight Converters.....13

Multi-Fit Wiring Harness.....14

4-WAY / 2-WAY FLAT CONNECTORS & WIRING

4-Way Flat Wire Harnesses.....15-16

4-Way Car & Trailer Connectors.....17-18

2-Way Car & Trailer Connectors.....18

DUST COVERS

Flat Dust Covers.....18

5-WAY FLAT CONNECTORS & WIRING

5-Way Car & Trailer Connectors.....19

5-Way Flat Wire Harnesses.....19

6-WAY ROUND PIN / SQUARE CONNECTORS & WIRING

6-Way Car & Trailer Connectors.....20

6-Way Molded Cables.....20

7-WAY RV BLADE CONNECTORS & WIRING

7-Way Thermo-Plastic / Metal Connectors.....21

7-Way Molded Trailer End Connectors.....22-25

7-Way Cold Weather Trailer End Connectors.....23

7-Way USCAR Pre-Wired Cables.....26

7-Way Molded Plug w/Cable Application Chart.....27

VEHICLE / TRAILER ADAPTERS / JUMPERS

Vehicle / Trailer Adapters / Jumpers.....28-31

ELECTRICAL ACCESSORIES

Connector Mounting Brackets.....32-33

Junction / Breaker Boxes.....34

Wiring / Hardware Components.....35

Battery Post Addapters / Isolators.....36

Electrical / Circuit Testers.....37

NEW PRODUCTS



54006-057

7-WAY MOLDED TRAILER END HEAVY DUTY WEATHER INSULATED BLUE SILICON - RV CLOCKING

- No cutting, splicing or taping of vehicle wires
- Solid, weatherproof, one-piece construction



119250

ZCI™ UNIVERSAL MODULITE®

- No cutting or splicing vehicle wiring
- Works with 2 or 3 wire system

FEATURED PRODUCTS



Series 54006-0xx

7-WAY CONNECTORS

- Standard 7-way cable
- Coiled application prevents sagging wires



002478

7-WAY MOLDED CONNECTOR W/ CABLE TRAILER END

- Heavy duty 7-way insulated cable
- Various length and combinations available

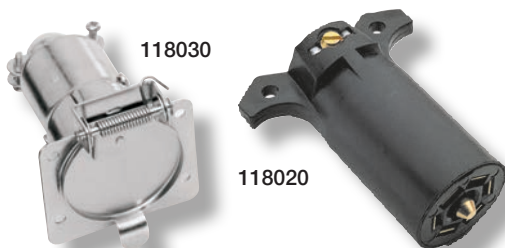

118030

118020

7-WAY STANDARD ELECTRICAL CONNECTORS

- Available with metal or plastic shell
- RV blade style



Series 119xxx

MODULITE® POWER MODULES

- Can be used on 2 or 3 wire system
- Designed to be used on most vehicles

DO I NEED A DIRECT WIRE CONNECTOR, CONVERTER, MODULITE® OR ZCI™?

**SELECTING
THE CORRECT
ELECTRICAL PRODUCT**

D, LS, G and most N Codes

BM, BT, BTT Code: Multiplexed system: ModuLite® HD Plus or Ultra required

A,E Code: 2 wire system: ModuLite® required
B,E Code: 3 wire system: ModuLite® required

B Code: 3 wire system: Converter required

A Code: 2 wire system: Direct wiring solutions

Direct wire system only



20252
4-Flat, 72" Long



702305
5-Way Flat, 4' Long



20224
USCAR 7-Way Connector

Works on non powered required systems only



119130
Converter



119178
Converter
w/circuit protection

Works on any standard system that requires a ModuLite®



119179
ModuLite® Protector and
119180
ModuLite® Protector
with Wiring Kit



119147
ModuLite®
HD Protector and
119148
ModuLite® HD Protector
with Wiring Kit



119177
ModuLite®
HD Protector w/BU

Works on most vehicles.



119190
ModuLite® HD Plus and
119191
ModuLite® HD Plus
with Wiring Kit



119192
ModuLite® Ultra

Snap, Don't Snip™



ZCI™

ZERO CONTACT
INTERFACE

119250
ZCI™ and
119251
ZCI™ with Wiring Kit

Revolutionary "Snap, Don't Snip™" design attaches to vehicle without cutting or splicing vehicle wiring.

A Code: 2 wire system.

Vehicles are listed as A when the vehicle's system matches the trailer's 2 wire system. You will know it is a 2 wire system if the vehicle's turn and brake functions are combined on one wire and the tail light function is on a separate wire. It is also important to make sure the vehicle's system is able to handle a normal load expected from one set of trailer lights. Directly wiring into the vehicle's system does not protect the vehicle from shorts or overloads. To ensure maximum vehicle protection and maximum trailer light brightness, a ModuLite® should be used.

B Code: 3 wire system. Converter required.

Vehicles are listed as B when the vehicle's system is different than the trailer's 2 wire system. This is when each function - turn, brake, and tail light - are on separate wires (3 wire system) and it has been determined that the vehicle's system is able to handle a normal load expected from one set of trailer lights. To ensure maximum vehicle protection and maximum trailer light brightness, a ModuLite® should be used.

A,E Code: 2 wire system. ModuLite® required.

Vehicles are listed as A,E when the vehicle's system matches the trailer's 2 wire system, meaning the vehicle's turn and brake functions are combined on one wire and the tail light function is on a separate wire. It has been determined that the vehicle's system is NOT able to handle a normal load expected from one set of trailer lights. When installing the ModuLite®, the brake input (red wire) will not be used.

B,E Code: 3 wire system. ModuLite® required.

Vehicles are listed as B,E when the vehicle's system is different than the trailer's 2 wire system, meaning the vehicle's functions are shared on one wire, the vehicle uses different voltages and frequencies to activate the rear combinations lamps, and the vehicle systems are NOT able to handle a normal load expected from one set of trailer lights. When installing the ModuLite® all input wires are used.

BM Code: Multiplexed wiring system. ModuLite® HD Plus or Ultra required.

Vehicles are listed as BM when the vehicle's system is different than the trailer's 2 wire system, meaning the vehicle's functions are shared on one wire, the vehicle uses different voltages and frequencies to activate the rear combinations lamps, and the vehicle systems are NOT able to handle a normal load expected from one set of trailer lights. Either the ModuLite® HD Plus or Ultra is required.

At time of installation, determine the type of the vehicle's shared system. For vehicles that share a tail and brake circuit, the tail input (brown wire) is not used. For vehicles that share a tail, brake and turn circuit the tail input (brown wire) and brake input (red wire) are not used.

BT Code: Brake/Tail multiplexed wiring system. ModuLite® HD Plus or Ultra required.

Vehicles are listed as BT when the vehicle's system is different than the trailer's 2 wire system. This means the vehicle's brake and tail functions are combined on one wire, the turn function is on a separate wire (known as multiplexed share brake and tail), and it has been determined that the vehicle's system is NOT able to handle a normal load expected from one set of trailer lights. When installing the ModuLite® HD Plus or Ultra, the tail input (brown wire) is not used.

BTT Code: Brake/Tail/Turn multiplexed wiring system. ModuLite® HD Plus or Ultra required.

Vehicles are listed as BTT when the vehicle's system is different than the trailer's 2 wire system, meaning the vehicle's brake, tail, and turn functions are combined on one wire (known as multiplexed shared brake, tail, & turn), and it has been determined that the vehicle's system is NOT able to handle a normal load expected from one set of trailer lights. When installing the ModuLite® HD Plus or Ultra, the tail input (brown wire) and brake input (red wire) are not used.



T-ONE® CONNECTORS - SIMPLE PLUG & PLAY

Vehicle to Trailer Harness, Vehicle Specific

If your vehicle does not have a trailer towing option installed, you'll need our T-One® Connector. A simple plug & play option for your trailers electrical connections.

Benefits of our Tekonsha® T-Ones include:

- "Factory" appearance
- Quick and easy installation
- Solid construction, built with our Surface Mount Technology
- Weatherproof connection when needed
- No cutting, splicing or taping of vehicle wires
- Includes ModuLite® or converter where needed
- 16 gauge bonded wire with 4-Flat plug and integrated cap
- Just plug in the T-One® Connector and you're ready to tow
- Limited 1 year warranty
- See application guide for vehicle specific applications



With our simple do-it-yourself instructions in every package, just plug in the T-One® and you're ready to tow! It couldn't be easier.

1. Locate



2. Unplug



3. Plug in

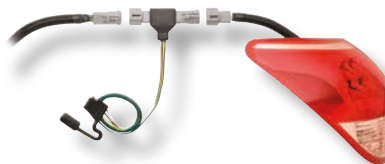

And you're ready to tow!

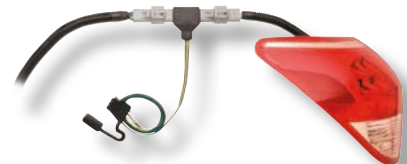

TOW PLUGS & FACTORY TOW PACKAGE WIRING HARNESSES

Vehicle to Trailer Harness, Vehicle Specific

- "Factory Appearance"
- Exact replacement for damaged factory wiring harnesses
- Quick and easy installation
- Available with 4-Flat or 7-Way Connector
- Limited 1 year warranty
- See application guide for vehicle specific applications



22550

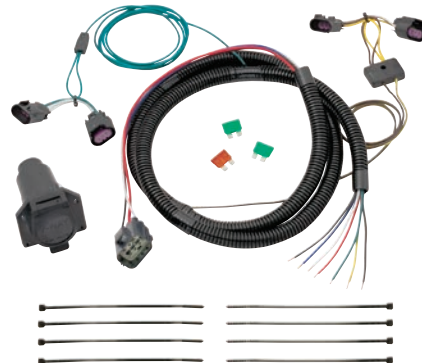

22111



20135

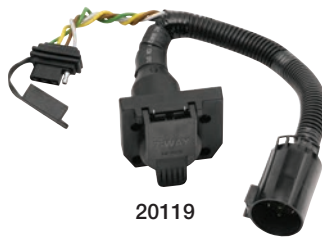

20119



20137



118015

20047

7-WAY VEHICLE COMPLETE KITS

- Allows for fully functional 7-Way (Tail Lights, Left/Right turn Brake, Reverse, Electric Brakes and 12 Volt +).
- Units are designed to handle PWM vehicle systems, when applicable.
- Mates with standard U.S. trailer 7-Way connectors.
- For simple mounting, choose 7-Way Mounting Box Part Numbers 118156, 118157 or 118159 (sold separately).

Part No.	Description	Packaging
22550	Tow Harness, Universal 7-Way Prep Kit, Including ModuLite® HD Protector w/Backup and Brake Control Harness	Boxed - Tekonsha
22111	2008-2012 Buick Enclave, All Styles and 2009-2012 Chevrolet Traverse, All Styles (See Application Guide for additional Info)	Boxed - Tekonsha
22112	2014-2016 RAM ProMaster 1500, 2500, 3500, All Models (See Application Guide for additional Info)	Boxed - Tekonsha
22113	2014-2017 Dodge Durango, All Styles (See Application Guide for additional Info)	Boxed - Tekonsha
22114	2015-2017 Ford Transit 150 and 250, All Styles (See Application Guide for additional Info)	Boxed - Tekonsha
22116	2015-2017 Ford Transit 350, All Styles (See Application Guide for additional Info)	Boxed - Tekonsha

MULTI-PLUG T-ONE® CONNECTOR

- Ability to tow trailers with different style trailer connectors
- Durable plastic shell
- Weather tight seal
- Attractive point-of-purchase packaging

Part No.	Description	Packaging
20119	7/4-Way Multi-Plug T-One® Connector (See Application Guide For Fit Information)	Clam
20135	7/4-Way Multi-Plug T-One® Connector (See Application Guide For Fit Information)	Clam
20137	7/4-Way Multi-Plug T-One® Connector (See Application Guide For Fit Information)	Clam

7-WAY U.S. CAR ELECTRICAL CONNECTORS

- Replacement for O.E.M. Connectors
- Durable plastic shell
- Weather tight seal

Part No.	Description	Packaging
118015	7-Way U.S. Car Connector (car end) (See Application Guide for fit information)	Clam
20047	7-Way U.S. Car Connector (car end) (See Application Guide for fit information)	Clam

Note: Use Installation Bracket 20212 for 118015

ModuLite® POWER MODULES

ULTIMATE VEHICLE PROTECTION

TRAILER LIGHT POWER MODULES

- Virtually eliminates additional electrical draw on the vehicle's taillight circuits
- Ensures maximum trailer light brightness
- Powers the trailer's stop, turn, tail and running lights without overloading vehicle electrical systems
- Compatible with:
 - 2 & 3 wire systems
 - PWM
 - Multiplex
 - LED tail lights

IDENTIFYING THE NEED FOR MODULITE®

- Today's vehicles have light gauge wire
- Computerized vehicle sensors monitor electrical current draw
- Without ModuLite® the sensors may give false readings
- Adding additional towing lights w/o ModuLite® may overload the system
- System problems and failure may occur without ModuLite®

HOW IT WORKS

- ModuLite® connects directly to vehicle's battery & powers the towing lights
- ModuLite® provides from 2.1 to 16 amps of power per circuit to the trailer lights, depending on the unit

INSTALLATION

ModuLite® power modules typically install in 30 to 45 minutes depending on the ease of routing the power supply wire from the battery to the rear of the vehicle.

WHEN YOU NEED MODULITE®

- Trailer has more than one light assembly per side and is equipped with multiple clearance or running lights
- If the tow vehicle may tow a variety of different trailers
- Vehicle is equipped with lamp out sensors or other electronic devices that could be damaged by voltage fluctuations
- Owners manuals caution against adding additional loads to electrical circuits

TRAILER AMPERAGE REQUIREMENTS - INCANDESCENT

Bulb Type	Candle Power	Rated Amps	Watts
57—1895	2	0.27	3.780
2057	32	2.10	26.880
	2	0.48	6.720
MR16	—	—	35
921	21	1.40	17.920
922	15	0.98	12.544
1141	21	1.44	18.432
93	15	1.04	13.312
105	12	1.07	13.696
1156	32	2.10	26.880
1157	32	2.10	26.880
	3	0.59	8.260
168	3	0.35	4.900
194	2	0.27	3.780

TRAILER AMPERAGE REQUIREMENTS - LED

Stop / Turn	Taillight / License	SM / CL
0.3	0.05	0.05

Without **ModuLite®** all the additional power required to supply the trailer lights (**represented by the red line**) pass through the vehicle's electrical system including the fuse panel, turn signal switch, taillight harness and lamp out sensor if so equipped.

WITHOUT MODULITE®

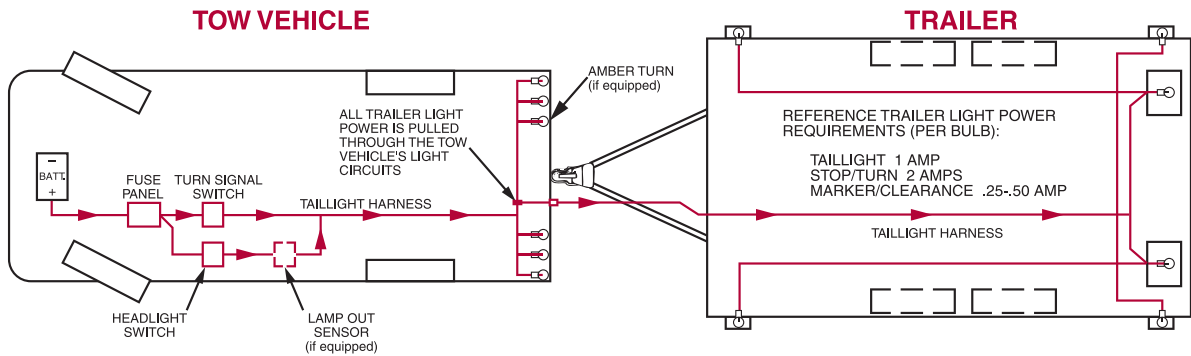

With **ModuLite®** all the additional power required to supply the trailer lights (**represented by the green line**) is supplied directly from the battery. Only a small amount of power is required from the fuse panel, turn signal switch, taillight harness and lamp out sensor if so equipped, to signal when to illuminate the trailer lights.

WITH MODULITE®

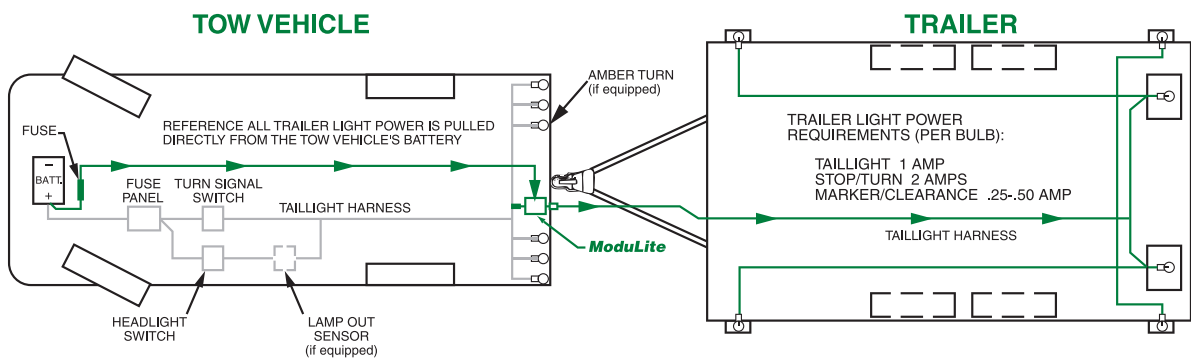



MODULITE® ZCI™ (ZERO CONTACT INTERFACE)

ZCI™ is the only product in the industry that has ZERO contact with the vehicle's lighting system. Using sensors that easily snap around wires for no direct contact, when electrical current is detected lights are engaged.

Snap, Don't Snip™ – NO CUTTING OR SPLICING VEHICLE WIRING!

- Isolates trailer light operation from the tow vehicle's electrical system
- Eliminates all Interference and Electrical draw on vehicle's lighting system
- Works with 2 or 3 wire systems
- Works with PWM, Multiplexed systems with 2 or 3 wire hookup and Low side switched vehicles
- Works with all known vehicle wiring systems including D, LS, G and most N codes.
- Rated for 4.2 amps for turn/stop & 7.5 amps for taillight trailer circuits
- Robust design allows for interior or exterior mounting



Part No.	Description	Packaging
119250	Modulite® ZCI™ (Zero Contact Interface)	Carton
119251	Modulite® ZCI™ (Zero Contact Interface) & Installation Kit	Carton

THE INTELLIGENT CHOICE

EASY

Snap, Don't Snip™ installation avoids wire cutting and splicing

SMART

ZCI™ technology detects electrical current flow and activates trailer lights

UNIVERSAL

Works on all current vehicle applications

SNAP, DON'T SNIP™

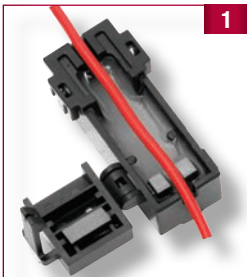

Patented Sensor Technology

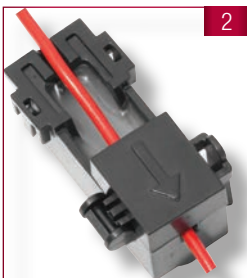

Don't take the chance of damaging your vehicle. Snipping, cutting, or splicing your wires can lead to:

- Shorts and damaged wiring
- Blown fuses
- Corrosion
- Warning lights and problem codes
- Costly and time consuming repairs
- Expensive dealership code resets

Our ZCI™ sensors easily snap over wires to detect an electrical current and engage trailer lights -- crucial for high-end vehicles with complex wiring in which snipping, cutting, or splicing voids the vehicle's electrical system warranty.

Have a leased vehicle? The ZCI™ is easy to remove without leaving any permanent damage. Take to your next vehicle with the same easy installation.



119179

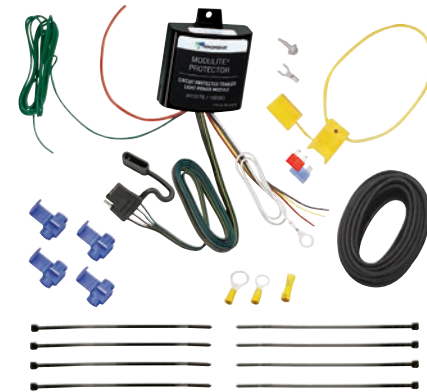

119180

MODULITE® PROTECTOR

- The unit is rated for up to **2.1 amps** for Turns/Stops circuits and **5.6 amps** for the Taillight circuit
- Has integrated, re-settable Short Circuit and Overload protection. Safeguards itself and the tow vehicle from shorts and installation wiring mishaps.
- The taillight circuit has been upgraded to work with vehicles that use a pulse width modulation (PWM). This ensures full brightness of the trailer lights during operation.
- Draws power directly from the vehicle battery. Uses less than 5mA of the vehicle circuit for sensing to turn the trailer functions on and off.
- Works with either LED and/or Incandescent bulbs (vehicle & trailer)
- The trailer brakes will override the hazard lamps when the brake is activated
- Will not work with vehicles with low-side switch or multiplex systems
- Can be used on a 2-wire or 3-wire system
- All solid-state components in a potted encapsulation
- Includes integrated protective cover

Part No.	Description	Packaging
119179	Modulite® Protector	Clam
119179-012	Modulite® Protector (12 Pack)	Bulk
119179-050	Modulite® Protector (50 Pack)	Bulk
119180	Modulite® Protector & Wiring Kit (119179 & 118151)	Clam



119147

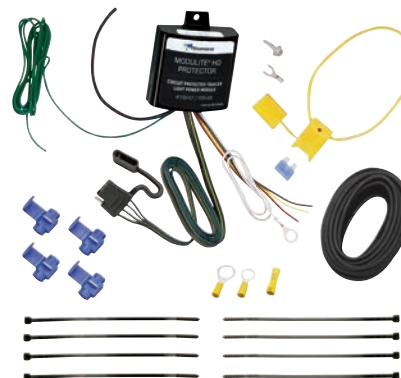

119148

MODULITE® HD PROTECTOR

- The unit is rated for up to **5.0 amps** for Turns/Stops circuits and **7.5 amps** for the Taillight circuit
- Has integrated, re-settable Short Circuit and Overload protection. Safeguards itself and the tow vehicle from shorts and installation wiring mishaps.
- The taillight circuit has been upgraded to work with vehicles that use a pulse width modulation (PWM). This ensures full brightness of the trailer lights during operation.
- Draws power directly from the vehicle battery. Uses less than 5mA of the vehicle circuit for sensing to turn the trailer functions on and off.
- Works with either LED and/or Incandescent bulbs (vehicle & trailer)
- The trailer brakes will override the hazard lamps when the brake is activated
- Will not work with vehicles with low-side switch or multiplex systems
- Can be used on a 2-wire or 3-wire system
- All solid-state components in a potted encapsulation
- Includes integrated protective cover

Part No.	Description	Packaging
119147	Modulite® HD Protector	Clam
119147-012	Modulite® HD Protector (12 Pack)	Bulk
119147-050	Modulite® HD Protector (50 Pack)	Bulk
119148	Modulite® HD Protector & Wiring Kit (119147 & 118151)	Clam



119190

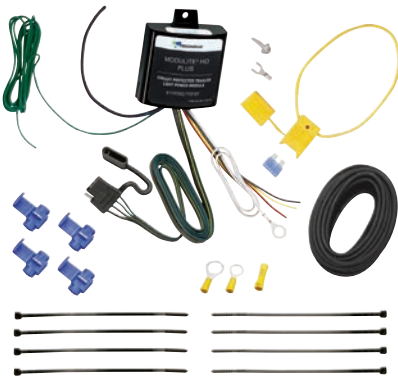

119191



119177

MODULITE® HD PLUS

- The unit is rated for up to **5.0 amps** for Turns/Stops circuits and **7.5 amps** for the Taillight circuit
- Works on all vehicle types including Standard, PWM and/or Multiplex systems
- Has integrated, re-settable Short Circuit and Overload protection. Safeguards itself and the tow vehicle from shorts and installation wiring mishaps.
- Draws power directly from the vehicle battery. Uses less than 5mA of the vehicle circuit for sensing to turn the trailer functions on and off.
- Works with either LED and/or Incandescent bulbs (vehicle & trailer)
- The trailer brakes will override the hazard lamps when the brake is activated
- Will not work with vehicles with low-side switch
- All solid-state components in a potted encapsulation
- Includes integrated protective cover

Part No.	Description	Packaging
119190	Modulite® HD Plus	Clam
119190-012	Modulite® HD Plus (12 Pack)	Bulk
119190-050	Modulite® HD Plus (50 Pack)	Bulk
119191	Modulite® HD Plus Includes Wiring Kit (119190 & 118151)	Clam

MODULITE® HD PROTECTOR W/BACKUP

- The unit is rated for up to **4.2 amps** for Turns/Stops circuits and **7.5 amps** for the Taillight circuit and **4.2 amps** for Back-Up circuit
- Integrated 5-flat electrical wiring connector. Fifth circuit added for surge brake lockout or backup light circuit on trailers
- Has integrated, re-settable Short Circuit and Overload protection, to safeguard itself and the tow vehicle from sorts and installation wiring mishaps
- The taillight circuit has been upgraded to work with vehicles that use a pulse width modulation (PWM); this will allow the converter to turn on fully and gives the trailer lights full brightness during activation
- Draws power directly from the vehicle battery and uses less than 5mA of the vehicle circuit for sensing to turn the trailer functions on and off
- Will work with either LED and/or Incandescent bulbs (vehicle & trailer)
- The trailer brakes will override the hazard lamps when the brake is activated
- Will not work with vehicles with low-side switch or multiplex systems
- Can be used on a 2-wire or 3-wire system
- All solid-state components in potted encapsulation
- Includes protective cover

Part No.	Description	Packaging
119177	Modulite® HD Protector w/Backup & 5-Flat Connector for Backup Light or Surge Brake Lockout Circuit	Clam

MODULITE® ULTRA

- The unit is rated for up to **5.0 amps** for Turns/Stops circuits and **16.0 amps** for the Taillight circuit
- Works on all vehicle types including Standard, PWM and/or Multiplex systems
- Has integrated, re-settable Short Circuit and Overload protection. Safeguards itself and the tow vehicle from shorts and installation wiring mishaps.
- Draws power directly from the vehicle battery. Uses less than 5mA of the vehicle circuit for sensing to turn the trailer functions on and off.
- Works with either LED and/or Incandescent bulbs (vehicle & trailer)
- The trailer brakes will override the hazard lamps when the brake is activated
- Will not work with vehicles with low-side switch
- All solid-state components in a potted encapsulation



119192

Part No.	Description	Packaging
119192	ModuLite® Ultra	Clam

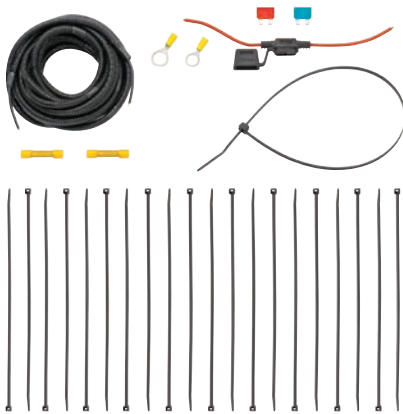

118150

MODULITE® WIRING KITS

Part No.	Description	Packaging
118150	Upgraded Wiring Kit for Installing all ModuLites®, Includes 20' wire pre-wrapped in convoluted tubing, (20) - 8" Wire Ties, 1 - 10 & 1 - 15 Fuses, and Weather Sealed Fuse Holder	Clam
118151	Wiring Kit For Installing All ModuLites®, Includes 20' wire pre-wrapped in convoluted tubing, (8) - Wire Ties, 10 Amp Fuse, and Weather Sealed Fuse Holder	Clam

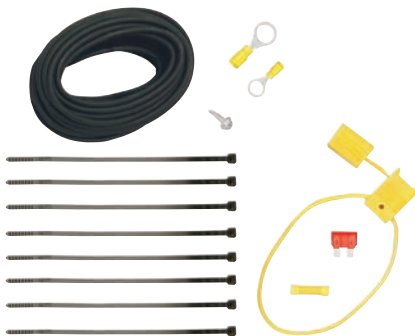

118151

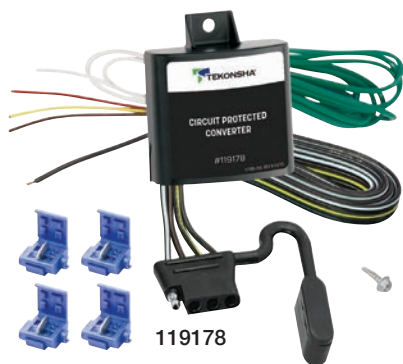

119178

TAILLIGHT CONVERTER WITH CIRCUIT PROTECTION

- The unit is rated for up to **2.1 amps** for Turns/Stops circuits and **5.6 amps** for Taillight circuit
- Adapts import and domestic vehicles with separate turn and stop lights (3-wire system) to standard trailer taillight wiring (2-wire system)
- Has integrated, resettable Sort Circuit and Overload protection to safeguard itself and the tow vehicle from shorts and installation wiring mishaps
- Will work with either LED and/or Incandescent bulbs (vehicle & trailer)
- All solid-state components in potted encapsulation
- Will not work with vehicles with low-side switch or multiplex systems
- Includes integrated protective cover

Part No.	Description	Packaging
119178	Taillight Converter with 60" 4-Flat Car End Connector	Clam
119178-012	Taillight Converter (12 Pack)	Bulk
119178-050	Taillight Converter (50 Pack)	Bulk



119130

TAILLIGHT CONVERTER

- The unit is rated for up to **2.1 amps** for Turns/Stops circuits and **7.5 amps** for Taillight circuit
- Adapts vehicles with separate turn and stop lights (3-wire system) to standard trailer taillight wiring (2-wire system)
- Works with either LED and/or Incandescent bulbs (vehicle & trailer)
- Designed not to send feedback thru the vehicle circuits
- All solid-state components
- Will not work with vehicles with low-side switch or multiplex systems
- Includes integrated protective cover

Part No.	Description	Packaging
119130	Taillight Converter with 60" 4-Flat Car End Connector	Clam
119130-012	Taillight Converter (12 Pack)	Bulk
119130-050	Taillight Converter (50 Pack)	Bulk
707295	Taillight Converter with 60" 4-Flat Car End Connector	Clam



707295

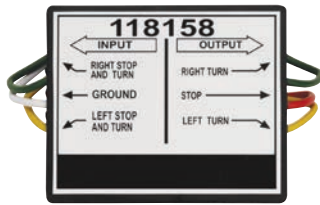

118158

2 TO 3-WAY TAILLIGHT CONVERTER

- Allows R.V.'s & other vehicles with 2 wire systems to tow vehicles and trailers with 3 wire systems

Part No.	Description	Packaging
118158	Connects A Tow Vehicle With A 2 Wire System To A Towed Vehicle With A 3 Wire System	Clam

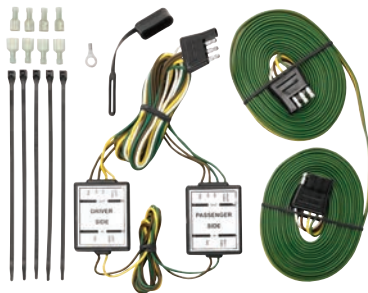

118821

TAILLIGHT ISOLATING DIODE SYSTEM

- Allows motorhome to power lights on towed vehicle w/o power feedback

Part No.	Description	Packaging
118821	Taillight Isolating System With 4-Flat	Clam



20250

MULTI-FIT WIRING HARNESS

- Easy do-it-yourself tow vehicle wiring kits for applications without T-One® Connectors
- Test light included on 20251 & 20252
- 16 gauge wire w/4-Flat dust cover

Part No.	Description	Packaging
20250	Vehicles w/common turn and stop lights and factory (O.E.M.) wiring harness. 12" length	Clam
20251	Designed for vehicles w/ separate turn and stop lights and no factory (O.E.M.) wiring harness. Converter specification of 2.1 amps per stop/turn circuit & 4.2 amps per tail circuit. Includes circuit tester & 60" leads.	Clam
20252	Vehicles w/common turn and stop lights and no factory (O.E.M.) wiring harness. Includes circuit tester. 72" length	Clam

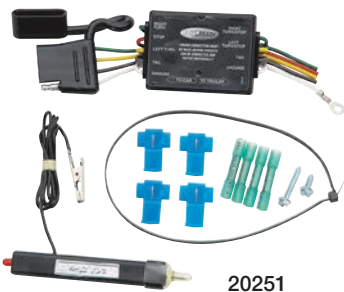

20251



4-WAY FLAT WIRE HARNESSSES

Color coded harnesses in various lengths available with car and trailer end connectors. Trailer ends can be purchased in straight lengths, loops, wunside or wishbone harness styles. Various length and combinations are available.

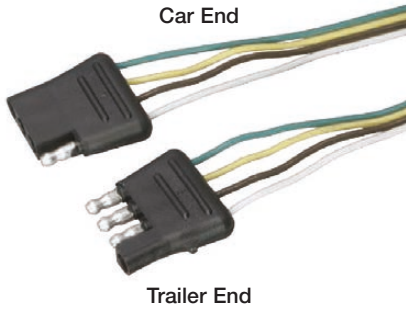

Wunside Harness Design

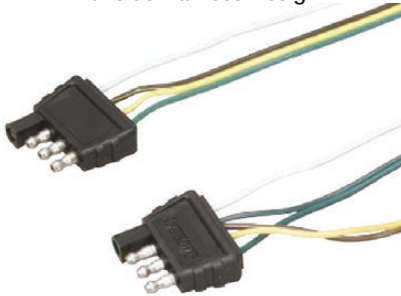

Wishbone Harness Design

NOTE: Various length and combinations available. Contact your Horizon Global Representative for details.

NOTE: All Horizon Global 4-Way Flat Wire Harnesses conform to SAE J1128 interface specifications.

4-Way Flat Car End Wire Harnesses

Part No.	Description	Packaging
002301	4-Way Flat 4 Ft. Car End, 18" Ground	Bulk
707275	4-Way Flat 4 Ft. Car End, 18" Ground	Clam
101469	4-Way Flat 6 Ft. Car End, 6 Ft. Ground	Bulk
707272	4-Way Flat 6 Ft. Car End, 6 Ft. Ground	Clam

4-Way Flat Trailer End Wire Harnesses

Part No.	Description	Packaging
18004001	4-Way Flat 12" Trailer End	Bulk

4-Way Flat Car End and Trailer End Wire Harnesses - Loop Style

Part No.	Description	Packaging
18185001	4-Way Flat 18" Loop w/Wire Taps	Bulk
18044001	4-Way Flat 48" Loop w/Wire Taps	Bulk
18045001	4-Way Flat 60" Loop w/Wire Taps	Bulk

4-Way Flat Trailer End Wire Harnesses - Wunside Style

Part No.	Description	Packaging
002401	4-Way Flat 18" Trailer End, Wunside Harness, 18" Ground	Bulk
707285	4-Way Flat 18" Trailer End, Wunside Harness, 18" Ground	Clam
002120	4-Way Flat 20 Ft. Trailer End, Wunside Harness, 3 Ft. Ground	Bulk
002125	4-Way Flat 25 Ft. Trailer End, Wunside Harness, 3 Ft. Ground	Bulk
002130	4-Way Flat 30 Ft. Trailer End, Wunside Harness, 3 Ft. Ground	Bulk

4-Way Flat Trailer End Wire Harnesses - Wishbone Style

Part No.	Description	Packaging
002402	4-Way Flat 18" Trailer End, Wishbone Harness, 18" Ground	Bulk
707286	4-Way Flat 18" Trailer End, Wishbone Harness, 18" Ground	Clam
002215	4-Way Flat 15 Ft. Trailer End, Wishbone Harness, 3 Ft. Ground	Bulk
002220	4-Way Flat 20 Ft. Trailer End, Wishbone Harness, 3 Ft. Ground	Bulk
108820	4-Way Flat 20 Ft. Trailer End, Wishbone Harness, 30" Ground	Bulk
707261	4-Way Flat 25 Ft. Trailer End, Wishbone Harness, 3 Ft. Ground	Clam
108825	4-Way Flat 25 Ft. Trailer End, Wishbone Harness, 3 Ft. Ground	Bulk
002230	4-Way Flat 30 Ft. Trailer End, Wishbone Harness, 3 Ft. Ground	Bulk
108830	4-Way Flat 30 Ft. Trailer End, Wishbone Harness, 3 Ft. Ground	Bulk
002235	4-Way Flat 35 Ft. Trailer End, Wishbone Harness, 3 Ft. Ground	Bulk
108835	4-Way Flat 35 Ft. Trailer End, Wishbone Harness, 30" Ground	Bulk
002240	4-Way Flat 40 Ft. Trailer End, Wishbone Harness, 3 Ft. Ground	Bulk
108840	4-Way Flat 40 Ft. Trailer End, Wishbone Harness, 3 Ft. Ground	Bulk

4-Way Flat Trailer End Wire Harnesses With Car Ends - Wishbone Style

Part No.	Description	Packaging
707270	4-Way Flat 18" Trailer End, Wishbone Harness, 18" Ground w/4 Ft. Car End, 18" Ground	Clam
707103	4-Way Flat 25 Ft. Trailer End, Wishbone Harness Kit w/Hardware, 3 Ft. Ground w/4 Ft. Car End, 18" Ground	Clam
707104	4-Way Flat 30 Ft. Trailer End, Wishbone HarnessKit w/Hardware, 3 Ft. Ground w/4 Ft. Car End, 18" Ground	Clam

Double Ended 4-Way Flat Wire Harness - Extension Style

Part No.	Description	Packaging
707254	Double Ended 4-Way 2 Ft. Cord (4-Way Flat Car & Trailer Ends)	Clam



4-WAY FLAT WIRE HARNESSSES

All 4-Flat Wiring conforms to SAE Spec. J1128 assuring you of consistent quality and reliability. 4-Flat harnesses come in a variety of lengths and packages to fit your every need.

Features Include:

- 18 gauge bonded wires
- Taillight, stop and turn functions printed on wire
- Ground wire runs full length of assembly

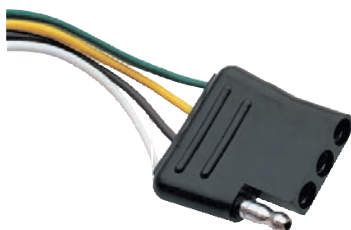
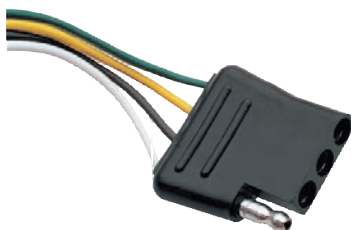

4-WAY FLAT CAR END WIRE HARNESSSES

- 7.5 Amps max per circuit

Part No.	Description	Packaging
118001	48" Car End - Includes 4 Wire Taps	Clam
118001-024	48" Car End (24 Pack)	Boxed
118001-200	48" Car End (200 Pack)	Boxed
118002	60" Car End - Includes 4 Wire Taps	Clam
118002-024	60" Car End (24 Pack)	Boxed
118002-200	60" Car End (200 Pack)	Boxed
118172-024	72" Car End (24 Pack)	Boxed
118172-150	72" Car End (150 Pack)	Boxed

4-WAY FLAT TRAILER END WIRE HARNESSSES

- 7.5 Amps max per circuit



Part No.	Description	Packaging
118004	12" Trailer End	Clam
118004-012	12" Trailer End (12 pack)	Boxed
118009	21' Trailer End	Clam
118033	48" Trailer End	Clam
118033-012	48" Trailer End (12 pack)	Bagged
118192	25' Trailer End w/dual taillight (brown) wires	Clam

4-WAY FLAT CAR AND TRAILER WIRE HARNESSSES

- 7.5 Amps max per circuit
- Includes both car and trailer 4-Flat Connectors wired end to end

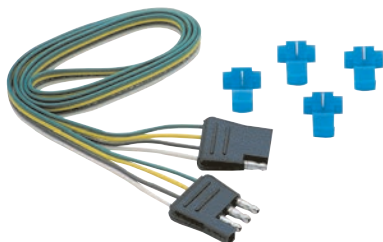

Part No.	Description	Packaging
118044	48" Car & Trailer End Loop - includes 4 wire taps	Clam
118044-010	48" Car & Trailer End Loops (10 pack)	Bagged
118044-175	48" Car & Trailer End Loops (175 pack)	Boxed
118045	60" Car & Trailer End Loop - includes 4 wire taps	Clam
118045-010	60" Car & Trailer End Loops (10 pack)	Boxed
118045-175	60" Car & Trailer End Loops (175 pack)	Boxed
118615-020†	72" Car & Trailer End Loops (20 pack)	Boxed
118636	24' Car & Trailer End Loop	Clam
118185	18" Car & Trailer End Loop - includes 4 wire taps	Clam
118185-025	18" Car & Trailer End Loops (25 pack)	Bagged
118185-200	18" Car & Trailer End Loops (200 pack)	Boxed

† = Available while supplies last.



4-WAY ROUND ELECTRICAL CONNECTORS

- Attractive chrome housing

Part No.	Description	Packaging
118077	4-Way Round Chrome Car End & Trailer End Plug Connectors	Clam
118101	4-Way Round Chrome Car End Connector	Clam
118102	4-Way Round Chrome Trailer End Connector	Clam



118043

4-FLAT CAR END CONNECTORS

- 7.5 Amps max per circuit

Part No.	Description	Packaging
118043	30" Car End "Knockout" Socket Connector 16 Gauge Wire (Un-Bonded). Requires 1-1/4" Hole.	Clam
118603	60" Car End "Knockout" Socket Connector 16 Gauge Wire (Un-Bonded). Requires 1-1/4" Hole.	Clam

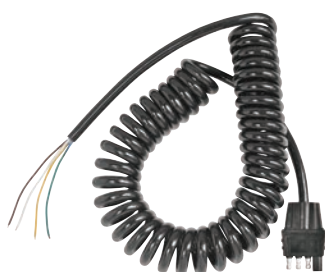

54000-026

4-WAY / 5-WAY FLAT WIRE HARNESSES WITH COILED CABLE

Coiled 14 gauge cable available with either 4-way or 5-way flat trailer end connectors. Cable extended length to 11 feet.

4-Way / 5-Way Flat Wire Harnesses With Coiled Cable

Part No.	Description	Packaging
54000-026	4-Way Flat Trailer End w/11' Coiled Cable	Bulk
54000-027	5-Way Flat Trailer End w/11' Coiled Cable	Bulk

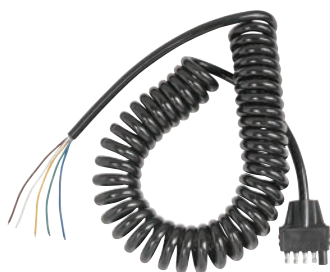

54000-027



4-WAY FLAT CONNECTORS WITH JACKETED CABLE

Color coded sealed cable available with trailer end connector, jacketed cable and 4' stripped wire leads. No exposed wires and sealed for environmental protection.

4-Way Flat Trailer End Connectors With Jacketed Cable

Part No.	Description	Packaging
787264	4-Way Flat 4' Trailer End w/Jacketed Cable	Bulk
787268	4-Way Flat 8' Trailer End w/Jacketed Cable	Bulk
787270	4-Way Flat 10' Trailer End w/Jacketed Cable	Bulk
787274	4-Way Flat 14' Trailer End w/Jacketed Cable	Bulk



787159

Double Ended 4-Way Flat Connector With Jacketed Cable - Extension Style

Part No.	Description	Packaging
787159	Double Ended 4-Way 88" Cord (4-Way Flat Trailer & 4-Way Square Car Ends)	Bulk

NOTE: Various length and combinations available. Contact your Horizon Global Representative for details.



118022

2-WAY FLAT WIRE HARNESS

- 2-Flat hookup - 12" loop

Part No.	Description	Packaging
118022	2-Flat Electrical Connector Loop - 12"	Clam



787301

4-WAY FLAT DUST COVER

Part No.	Description	Packaging
104393	4-Way Flat Dust Cover (100 Pack)	Bulk
787301	4-Way Flat Dust Cover (Single)	Clam



20112

4-WAY FLAT DUST COVER

Part No.	Description	Packaging
20112	Dust Cover For 4-Flat Connector (Economy)	Clam
20112-024	Dust Cover For 4-Flat Connector (24 Pack)	Boxed



118147-025†

4-WAY FLAT COVER W/LED TESTER

Part No.	Description	Packaging
118147-025†	4-Flat Cover w/LED Tester (25 pack)	Bagged



20118

5-WAY FLAT DUST COVER

Part No.	Description	Packaging
20118	Dust Cover, 5-Flat Connector	Clam
20118-024	Dust Cover, 5-Flat Connector (24 pack)	Boxed

† = Available while supplies last.

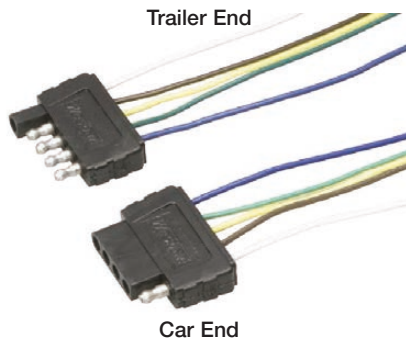

5-WAY FLAT WIRE HARNESSSES

Color coded harnesses in various lengths available with car and trailer end connectors. Trailer ends can be purchased in wunside or wishbone harness styles. Various length and combinations are available.

5-Way Flat Car End Wire Harnesses

Part No.	Description	Packaging
702305	5-Way Flat 4 Ft. Car End , 18" Ground, 4 Ft. Auxiliary	Clam
002309	5-Way Flat 6 Ft. Car End, 6 Ft. Ground, 6 Ft. Auxiliary	Bulk
707273	5-Way Flat 6 Ft. Car End, 6 Ft. Ground, 6 Ft. Auxiliary	Clam

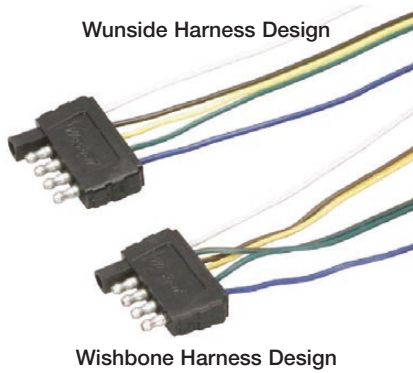

5-Way Flat Trailer End Wire Harnesses - Wunside Style

Part No.	Description	Packaging
702405	5-Way Flat 18" Trailer End, Wunside Harness, 18" Ground, 18" Auxiliary	Clam

5-Way Flat Trailer End Wire Harnesses - Wishbone Style

Part No.	Description	Packaging
002409	5-Way Flat 4 Ft. Trailer End, Wishbone Harness, 4 Ft. Ground, 4 Ft. Auxiliary	Bulk
707283	5-Way Flat 4 Ft. Trailer End, Wishbone Harness, 4 Ft. Ground, 4 Ft. Auxiliary	Clam
002275	5-Way Flat 25 Ft. Trailer End, Wishbone Harness, 4 Ft. Ground, 5 Ft. Auxiliary	Bulk
702275	5-Way Flat 25 Ft. Trailer End, Wishbone Harness, 4 Ft. Ground, 5 Ft. Auxiliary	Clam
002280	5-Way Flat 30 Ft. Trailer End, Wishbone Harness, 4 Ft. Ground, 5 Ft. Auxiliary	Bulk
002285	5-Way Flat 35 Ft. Trailer End, Wishbone Harness, 4 Ft. Ground, 5 Ft. Auxiliary	Bulk
002290	5-Way Flat 40 Ft. Trailer End, Wishbone Harness, 4 Ft. Ground, 5 Ft. Auxiliary	Bulk

NOTE: Various length and combinations available. Contact your Horizon Global Representative for details.

5-Way Flat Trailer End Wire Harnesses With Car End - Wishbone Style

Part No.	Description	Packaging
707105	5-Way Flat 25 Ft. Trailer End, Wishbone Harness Kit w/Hardware, 4 Ft. Ground, 5 Ft. Auxiliary w/6 Ft. Car End, 6 Ft. Ground, 6 Ft. Auxiliary	Clam

Double Ended 5-Way Flat Wire Harness - Extension Style

Part No.	Description	Packaging
707255	Double Ended 5-Way 2 Ft. Cord (5-Way Flat Car and Trailers Ends)	Clam

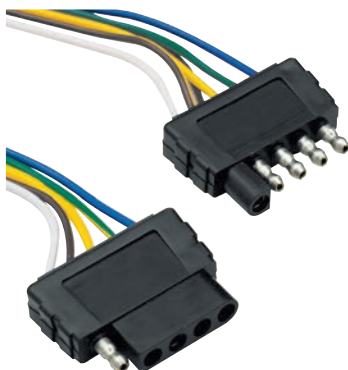

5-WAY FLAT ELECTRICAL WIRE HARNESSSES

- Fifth wire added for surge brake lockout or backup light circuit on today's newer trailers
- 7.5 amps maximum per circuit

Part No.	Description	Packaging
118016	5-Flat 72" Car End Wiring Harness	Clam
118016-025	5-Flat 72" Car End Wiring Harness (25 pack)	Boxed
118017	5-Flat 48" Trailer End Wiring Harness	Clam
118215	5-Flat 72" Car & Trailer End Loop	Clam

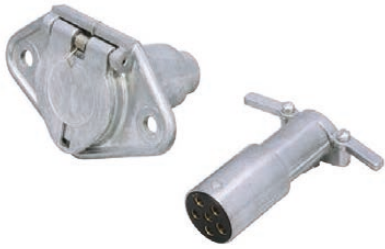

6-WAY METAL CONNECTORS

Heavy duty die cast corrosion resistant housing, spring loaded car end cover, and coded terminals. Interchangeable with other standard 6-way connectors.

Part No.	Description	Packaging
62	6-Way Metal Car End Only	Bulk
54-60-101	6-Way Metal Car End Only	Bagged
63	6-Way Metal Trailer End Only	Bulk
54-60-103	6-Way Metal Trailer End Only	Bagged



6-WAY ELECTRICAL CONNECTORS

- Durable metal shell

Part No.	Description	Packaging
118036	6-Way Heavy-Duty Metal Car End Socket Connector	Clam
118036-006	6-Way Heavy-Duty Metal Car End Socket Connectors (6 pack)	Bagged
118036-050	6-Way Heavy-Duty Metal Car End Socket Connectors (50 pack)	Boxed
118037	6-way Heavy-Duty Metal Trailer End Plug Connector	Clam
118037-006	6-Way Heavy-Duty Metal Trailer End Plug Connectors (6 pack)	Bagged
118037-050	6-Way Heavy-Duty Metal Trailer End Plug Connectors (50 pack)	Boxed



6-WAY SQUARE WIRE HARNESSES

- Used on tent trailers
- 7.5 amps maximum per circuit

Part No.	Description	Packaging
30105	6-Way Square Connector Kit (Male & Female Ends) - 12"	Clam
118104	6-Way Square to 4-Flat Adapter - 12" Loop	Bagged



118104

6-WAY SUPER SEALED CAR ENDS WITH CABLE

Prewired, 6-Way car end sealed with 2, 4 or 7 ft. of UL listed 6-way cable (White, Blue and Red-10 gauge; Yellow, Brown and Green-14 gauge). Solid brass terminals and housing of industrial-strength, glass-filled thermoplastic, door with EPDM rubber gasket and heavy duty stainless steel spring. Manufactured with UL listed PVC for flexibility and features molded construction to encapsulate terminals and wires. Patent Pending.

Part No.	Description	Packaging
50-86-004	6-Way Super Sealed Car End w/4 Ft. Cable	Bulk
50-86-007	6-Way Super Sealed Car End w/7 Ft. Cable	Bulk
51-86-007	6-Way Super Sealed Car End w/7 Ft. Cable	Clam



6-WAY MOLDED TRAILER END CONNECTORS WITH CABLE

6-Way heavy duty series molded connector available with two different wires. Can be purchased with 3-10 gauge and 3-14 gauge wires (primary wire gauges; Yellow, Brown, Green - 14 gauge) or can be purchased with 6-14 gauge wires. Both models feature encapsulated terminals and wires to form one weather resistant, non-corrosive assembly. Molded connector can be used with thermo-plastic or metal 6-way car end connectors. Various length and combinations are available.

6-Way Molded Trailer End with Cable, 3-10 gauge, 3-14 gauge

Part No.	Description	Packaging
50-61-008	6-Way Molded Trailer Cord w/8 Ft. Cable, 3-10 gauge, 3-14 gauge	Bulk

6-Way Molded Trailer End with Cable, 6-14 gauge

Part No.	Description	Packaging
50-61-104	6-Way Molded Trailer Cord w/4 Ft. Cable, 6-14 gauge	Bulk
50-61-106	6-Way Molded Trailer Cord w/6 Ft. Cable, 6-14 gauge	Bulk
50-61-108	6-Way Molded Trailer Cord w/8 Ft. Cable, 6-14 gauge	Bulk



NOTE: Various length and combinations available. Contact your Horizon Global Representative for details.



7-WAY THERMO-PLASTIC CONNECTORS



12-volt thermo-plastic connector with brass contact to prevent corrosion. Built-in cable clamp prevents wear on 7-way cable. Unique method of forming contact pins provides for easy connecting and disconnecting.

Part No.	Description	Packaging
50-77-001	7-Way Plastic Car End Only	Bulk
54-77-001	7-Way Plastic Car End Only	Bagged
50-77-003	7-Way Plastic Trailer End Only	Bulk
54-77-003	7-Way Plastic Trailer End Only	Bagged

7-WAY METAL CONNECTORS

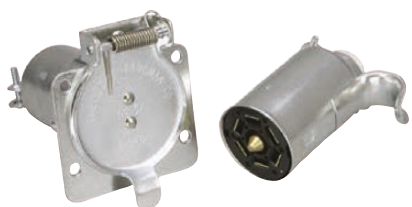

12-volt metal connector with plastic core. Metal housing is 20 gauge steel, zinc plated to protect against corrosion. Trigger grip for easy disconnection.

Part No.	Description	Packaging
50-57-503	7-Way Metal Car End Only	Bulk
54-57-503	7-Way Metal Car End Only	Bagged
50-57-007	7-Way Metal Trailer End Only	Bulk
54-57-007	7-Way Metal Trailer End Only	Bagged

7-WAY STANDARD ELECTRICAL CONNECTORS

- Available with metal or plastic shell
- RV blade style



Part No.	Description	Packaging
118020	7-Way Plastic Car End Socket Connector	Clam
118020-006	7-Way Plastic Car End Socket Connectors (6 pack)	Bulk
118020-050	7-Way Plastic Car End Socket Connectors (50 pack)	Boxed
118021	7-Way Plastic Trailer End Plug Connector	Clam
118021-006	7-Way Plastic Trailer End Plug Connectors (6 pack)	Bulk
118021-050	7-Way Plastic Trailer End Plug Connectors (50 pack)	Boxed
118030	7-Way Metal Car End Socket Connector	Clam
118031	7-Way Metal Trailer End Plug Connector	Clam

7-WAY SUPER SEALED CAR ENDS WITH CABLE



Prewired 7-way car end sealed with 2, 4, 7 or 9 ft. of UL listed 7-way cable. Solid brass terminals, housing of industrial-strength, glass-filled thermoplastic, door with EPDM rubber gasket and heavy duty stainless steel spring. Manufactured with UL listed PVC for flexibility and features molded construction to encapsulate terminals and wires. Patent Pending.

Part No.	Description	Packaging
50-87-002	7-Way Super Sealed Car End w/2 Ft. Cable	Bulk
51-87-002	7-Way Super Sealed Car End w/2 Ft. Cable	Clam
50-87-004	7-Way Super Sealed Car End w/4 Ft. Cable	Bulk
51-87-004	7-Way Super Sealed Car End w/4 Ft. Cable	Clam
50-87-007	7-Way Super Sealed Car End w/7 Ft. Cable	Bulk
51-87-007	7-Way Super Sealed Car End w/7 Ft. Cable	Clam
50-87-009	7-Way Super Sealed Car End w/9 Ft. Cable	Bulk



NOTE: Various length and combinations available. Contact your Horizon Global Representative for details.

7-WAY MOLDED TRAILER END CONNECTORS WITH CABLE - RV CLOCKING*



7-way plastic trailer connector molded to heavy duty 7-way insulated cable. Made with self-cleaning contacts and molded to encapsulate terminals and wires to form one weather resistant, non-corrosive assembly. Primary wire gauges within the insulated cable are: Black and White-10 gauge, Blue-12 gauge, Brown-Red-Green-Yellow-14 gauge. Molded connector can be used with thermo-plastic or metal 7-way car end connectors. Various length and combinations are available.

7-Way Molded Trailer End with Cable

Part No.	Description	Packaging
50-67-907	7-Way Molded Trailer Cord w/4 Ft. Cable	Bulk
50-67-001	7-Way Molded Trailer Cord w/6 Ft. Cable	Bulk
51-67-001	7-Way Molded Trailer Cord w/6 Ft. Cable	Clam
50-67-002	7-Way Molded Trailer Cord w/7 Ft. Cable	Bulk
50-67-003	7-Way Molded Trailer Cord w/8 Ft. Cable	Bulk
51-67-003	7-Way Molded Trailer Cord w/8 Ft. Cable	Clam
50-67-004	7-Way Molded Trailer Cord w/9 Ft. Cable	Bulk
50-67-005	7-Way Molded Trailer Cord w/10 Ft. Cable	Bulk
50-67-007	7-Way Molded Trailer Cord w/12 Ft. Cable	Bulk
50-67-103	7-Way Molded Trailer Cord w/15 Ft. Cable	Bulk
50-67-106	7-Way Molded Trailer Cord w/18 Ft. Cable	Bulk

7-Way Molded Trailer End with Cable and Breakaway Switch

Part No.	Description	Packaging
50-67-410	7-Way Molded Trailer w/10 Ft. Cable and Breakaway Switch	Bulk

Double Ended 7-Way Molded Trailer End with Cable

Part No.	Description	Packaging
50-67-901	Double Ended 7-Way Molded Trailer Cord w/6 Ft. Cable	Bulk
50-67-210	Double Ended 7-Way Molded Trailer Cord w/8 Ft. Cable	Bulk
51-67-210	Double Ended 7-Way Molded Trailer Cord w/8 Ft. Cable	Clam



002478

NOTE: Various length and combinations available. Contact your Horizon Global Representative for details.

7-WAY MOLDED CONNECTOR W/ CABLE - TRAILER END



7-Way plastic trailer connector molded to heavy duty 7-Way insulated cable. Made with self-cleaning contacts and molded to encapsulate terminals and wires to form one weather resistant, non-corrosive assembly. Primary wire gauges within the insulated cable are: Black and White-10 gauge, Blue-12 gauge, Brown-Red-Green-Yellow-14 gauge. Molded connector can be used with thermo-plastic or metal 7-way car end connectors.

7-Way Molded Connector w/ Cable - Trailer End

Part No.	Description	Packaging
002478	7-Way Molded Trailer End w/ 8' Cable	Bulk

† = Available while supplies last.



7-WAY HEAVY DUTY COLD WEATHER INSULATED BLUE SILICON TRAILER END WITH CABLE - RV CLOCKING*

7-way trailer connector molded to cold environment heavy duty blue silicon 7-way insulated cable (rated to -55°C/-67°F). Made with self-cleaning contacts and molded to encapsulate terminals and wires to form one weather resistant, non-corrosive assembly. Primary wire gauges within the insulated cable are: Black-White-Red-10 gauge, Blue-Brown-Green-Yellow-14 gauge. Molded connector can be used with thermo-plastic or metal 7-way car end connectors. Various length and combinations are available.

*NOTE: Reference Wiring Diagrams for pin locations.

7-Way Cold Weather Molded Trailer End Connectors With Cable

Part No.	Description	Packaging
54006-057	7-Way Cold Weather Molded Trailer Cord w/6 Ft. Cable	Bulk
54006-058	7-Way Cold Weather Molded Trailer Cord w/8 Ft. Cable	Bulk
54006-059	7-Way Cold Weather Molded Trailer Cord w/10 Ft. Cable	Bulk

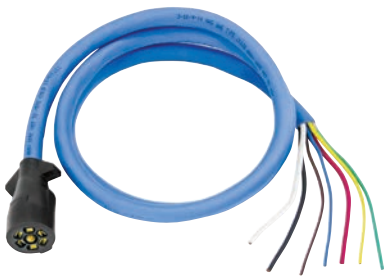

7-WAY COLD WEATHER MOLDED TRAILER END CONNECTORS WITH CABLE - COLD WEATHER CLOCKING*

7-way trailer connector molded to cold environment heavy duty blue silicon 7-way insulated cable (rated to -55°C/-67°F). Made with self-cleaning contacts and molded to encapsulate terminals and wires to form one weather resistant, non-corrosive assembly. Primary wire gauges within the insulated cable are: Black-White-Red-10 gauge, Blue-Brown-Green-Yellow-14 gauge. Molded connector can be used with thermo-plastic or metal 7-way car end connectors. Various length and combinations are available.

*NOTE: Reference Wiring Diagrams for pin locations.

7-Way Cold Weather Molded Trailer End Connectors With Cable

Part No.	Description	Packaging
54006-009	7-Way Cold Weather Molded Trailer Cord w/6 Ft. Cable	Bulk
54006-010	7-Way Cold Weather Molded Trailer Cord w/8 Ft. Cable	Bulk
54006-015	7-Way Cold Weather Molded Trailer Cord w/10 Ft. Cable	Bulk
54006-016	7-Way Cold Weather Molded Trailer Cord w/12 Ft. Cable	Bulk



54006-043

7-WAY CONNECTORS

- Durable connectors

Part No.	Description	Packaging
54006-043	Coiled 7-Way Molded Trailer Connector, 6'	Bagged
54006-049	Coiled 7-Way Molded Trailer Connector, 6'	Boxed
54006-044	Coiled 7-Way Molded Trailer Connector, 8'	Bagged
54006-050	Coiled 7-Way Molded Trailer Connector, 8'	Boxed
54006-045	Coiled 7-Way Molded Trailer Connector, 10'	Bagged
54006-051	Coiled 7-Way Molded Trailer Connector, 10'	Boxed
54006-046	Coiled 7-Way Molded Trailer Connector, 12'	Bagged
54006-052	Coiled 7-Way Molded Trailer Connector, 12'	Boxed



118664

6-WAY / 7-WAY TRAILER EXTENSION

- Durable connectors
- 7 ft. lead reaches almost anywhere

Part No.	Description	Packaging
118666	6-Way Connector - extension cable 7'	Bagged
118664	7-Way Connector - extension cable 7'	Bagged



7-WAY MOLDED TRAILER END CONNECTOR REPLACEMENT KIT - RV CLOCKING*

Easy to install, complete with instructions. Features self cleaning contacts, one foot of cable, butt connectors and weather resistant shrink tubing.

7-Way Molded Trailer End with Cable

Part No.	Description	Packaging
54-67-525	7-Way Molded Trailer End Connector Replacement Kit w/1 Ft. Cable	Bagged

*NOTE: Reference Wiring Diagrams for pin locations.



7-WAY MOLDED TRAILER CONNECTORS WITH CABLE - TRAILER CLOCKING*

7-way plastic connector molded to heavy duty 7-way insulated cable using trailer clocking*. Provides 7-way connector contact color coding more conducive to horse and livestock trailers verses RV trailers. Made with self-cleaning contacts and molded to encapsulate terminals and wires to form one weather resistant, non-corrosive assembly. Permits the trailer to have the clean appearance and environmental advantages of a sealed, molded 7-way cord. Primary wire gauges within the insulated cable are: Black and White-10 gauge, Blue-12 gauge, Brown-Red-Green-Yellow-14 gauge.

NOTE: Various length and combinations available. Crimped junction box terminals can be added. Contact your Horizon Global Representative for details.

Part No.	Description	Packaging
50-67-614	7-Way Molded Trailer Cord w/4' Cable	Bulk
50-67-616	7-Way Molded Trailer Cord w/6' Cable	Bulk
50-67-618	7-Way Molded Trailer Cord w/8' Cable	Bulk
50-67-620	7-Way Molded Trailer Cord w/10' Cable	Bulk

*NOTE: Reference Wiring Diagrams for pin locations.



90° 7-WAY PRE-WIRED CABLES FOR HOOK-UP OF FIFTH WHEEL AND GOOSENECK TRAILERS

7-way 90° connector molded to heavy duty 7-way insulated cable for fifth wheel or gooseneck trailer applications. Allows remote wiring in pickup beds or other hard to access areas. 90° molded from flame retardant material. Features a patented mounting bracket that allows for installation in virtually all pickup models and styles and includes self-tapping stainless steel mounting screws. Manufactured with UL listed 10/2, 12/1 and 14/4 jacketed cable.

Part No.	Description	Packaging
50-97-407	90° 7-Way Molded Trailer Cord w/7 Ft. Cable	Bulk
51-97-407	90° 7-Way Molded Trailer Cord w/7 Ft. Cable	Clam
54700-010	Screw Kit for Aluminum Beds	Bulk



90° VEHICLE SPECIFIC COMPLETE KITS

Part No.	Description	Packaging
50-97-410	90° 7-Way Complete Connector Kit w/9 Ft. Cable	Bulk
51-97-410	90° 7-Way Complete Connector Kit w/9 Ft. Cable	Box
50-97-411	90° 7-Way Complete Connector Kit w/9 Ft. Cable	Bulk
51-97-411	90° 7-Way Complete Connector Kit w/9 Ft. Cable	Box
50-97-412	90° 7-Way Complete Connector Kit w/9 Ft. Cable	Bulk
51-97-412	90° 7-Way Complete Connector Kit w/9 Ft. Cable	Box
54700-003	90° 7-Way Complete Connector Kit w/7 Ft. Cable	Bulk
54701-003	90° 7-Way Complete Connector Kit w/7 Ft. Cable	Box
54700-004	90° 7-Way Complete Connector Kit w/7 Ft. Cable	Bulk
54701-004	90° 7-Way Complete Connector Kit w/7 Ft. Cable	Box
54700-007	90° 7-Way Complete Connector Kit w/7 Ft. Cable	Bulk
54700-009	90° 7-Way Complete Connector Kit w/9 Ft. Cable	Bulk
54701-007	90° 7-Way Complete Connector Kit w/7 Ft. Cable	Box
54701-009	90° 7-Way Complete Connector Kit w/9 Ft. Cable	Box

SEE APPLICATION CHART ON PAGE C-27 FOR VEHICLE SPECIFIC APPLICATIONS.



20110



20147



20129



20140



20223

USCAR VEHICLE SPECIFIC COMPLETE KITS

Part No.	Description	Packaging
20110	USCAR 7-Way Complete Connector Kit w/7 Ft. Cable	Clam
20111	USCAR 7-Way Complete Connector Kit w/7 Ft. Cable	Clam
20113	USCAR 7-Way Complete Connector Kit w/7 Ft. Cable	Clam
20146	Fifth Wheel Adapter Harness, 7-Way Flat Pin U.S. Car Connector Assembly 9 ft., Dodge, Ford, GM, RAM & Toyota	Clam
20147	USCAR 7 Way Replacement Harness	Clam

PRE-WIRED CABLES FOR HOOK-UP OF FIFTH WHEEL AND GOOSENECK TRAILERS

Allows remote wiring in pickup beds or other hard to access areas when towing a fifth wheel or gooseneck trailer, upgrading from OEM wiring.

Part No.	Description	Packaging
20128	4-Flat (OEM) to 6-Way Connector Kit w/7 Ft. Cable	Clam
20129	4-Flat (OEM) to 6-Way Connector Kit w/7 Ft. Cable	Clam
20131	4-Flat (OEM) to 7-Way Connector Kit w/7 Ft. Cable	Clam
20140	Fifth Wheel Adapter Harness, 7-Way Flat Pin USCAR connector assembly w/7' Cable w/Pigtails for Choice of Hardwiring 6- or 7-Way Connector, GM, Ford, Dodge, Toyota	Clam

USCAR 7-WAY PRE-WIRED CABLES FOR HOOK-UP OF FIFTH WHEEL AND GOOSENECK TRAILERS

Allows remote wiring in pickup beds or other hard to access areas when towing a fifth wheel or gooseneck trailer, using an OEM USCAR connector. Features durable plastic housing with weather tight seal.

Part No.	Description	Packaging
20224	USCAR 7-Way Connector w/4 Ft. Cable	Clam
20223	USCAR 7-Way Connector w/7 Ft. Cable	Clam

SEE APPLICATION CHART ON PAGE C-27 FOR VEHICLE SPECIFIC APPLICATIONS.

7-WAY 90° / PRE-WIRED CABLE APPLICATION CHART



Make/Model	Style	Years	POS	7 ft.	9 ft.	90/9ft.	90/9ft.	90/7 ft.	90/7 ft.
				Clam	Clam	Boxed	Bulk	Boxed	Bulk
Chevrolet/GMC									
Silverado/Sierra 1500	w/Factory 7-Way	99-17	PU3	20110	20146	51-97-410	50-97-410	54701-003	54700-003
Silverado/Sierra 1500 HD	(Classic), w/Factory 7-Way	01-07	PU3	20110	20146	51-97-410	50-97-410	54701-003	54700-003
Silverado/Sierra 2500	w/Factory 7-Way	99-04	PU3	20110	20146	51-97-410	50-97-410	54701-003	54700-003
Silverado/Sierra 2500 HD	w/Factory 7-Way	01-16	PU3	20110	20146	51-97-410	50-97-410	54701-003	54700-003
Silverado/Sierra 3500	(Classic), w/Factory 7-Way	01-07	PU3	20110	20146	51-97-410	50-97-410	54701-003	54700-003
Silverado/Sierra 3500 HD	w/Factory 7-Way	07-16	PU3	20110	20146	51-97-410	50-97-410	54701-003	54700-003
Dodge/Ram									
Ram 1500	w/Factory 7-Way	00-08	PU3	20111		51-97-411	50-97-411		
Ram 1500	w/Factory 7-Way	09-17	PU3	20110	20146	51-97-410	50-97-410	54701-003	54700-003
Ram 2500	w/Factory 7-Way	00-09	PU3	20111		51-97-411	50-97-411		
Ram 2500	w/Factory 7-Way	10-17	PU3	20110	20146	51-97-410	50-97-410	54701-003	54700-003
Ram 3500	w/Factory 7-Way	00-09	PU3	20111		51-97-411	50-97-411		
Ram 3500	w/Factory 7-Way	10-17	PU3	20110	20146	51-97-410	50-97-410	54701-003	54700-003
Ford									
F-150	w/Factory 7-Way	97-17	PU3	20110	20146	51-97-410	50-97-410	54701-003	54700-003
F-250	Styleside, w/Factory 7-Way	97-99	PU3	20110	20146	51-97-410	50-97-410	54701-003	54700-003
F-250/350 Super Duty	w/Factory 7-Way	11-16	PU3	20110	20146	54701-009	54700-009	54701-007	54700-007
F-250/350 Super Duty	w/Factory 7-Way	99-10	PU3	20110	20146	51-97-410	50-97-410	54701-003	54700-003
F-450 Super Duty	w/Factory 7-Way	11-16	PU3	20110	20146	54701-009	54700-009	54701-007	54700-007
F-450 Super Duty	w/Factory 7-Way	99-10	PU3	20110	20146	51-97-410	50-97-410	54701-003	54700-003
F-550 Super Duty	w/Factory 7-Way	99-11	PU3	20110	20146	51-97-410	50-97-410	54701-003	54700-003
Lincoln									
Mark LT	w/Factory 7-Way	06-08	PU3	20110	20146	51-97-410	50-97-410	54701-003	54700-003
Nissan									
Titan	w/Factory 7-Way	04-14	PU3	20110	20146	51-97-410	50-97-410	54701-003	54700-003
Toyota									
Tundra	w/Factory 7-Way	07-09	PU3	20113		51-97-412	50-97-412	54701-004	54700-004
Tundra	w/Factory 7-Way	10-16	PU3	20110	20146	51-97-410	50-97-410	54701-003	54700-003



Step-Down Style

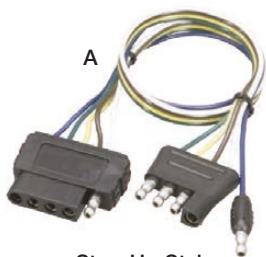

Step-Up Style

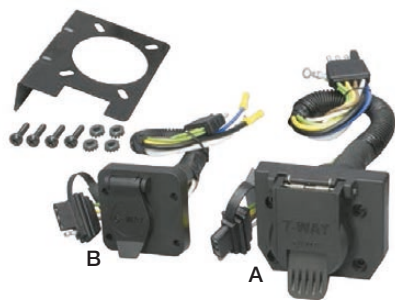

Dual Port - Step-Up Style



VEHICLE/TRAILER ADAPTERS

Adapters for a quick switch from one style plug to another when towing multiple trailers.

Standard Vehicle/Trailer Adapters - Step - Down Style

Part No.	Description	Packaging
50-98-054	6-Way Round Pin to 4-Way Flat (Photo A)	Bulk
707281	6-Way Round Pin to 4-Way Flat (Photo A)	Clam
50-98-050	7-Way Blade to 4-Way Flat (Photo B)	Bulk
54-98-050	7-Way Blade to 4-Way Flat (Photo B)	Bagged
707282	7-Way Blade to 4-Way Flat (Photo H)	Clam
50-98-052	7-Way Round Pin to 4-Way Flat (Photo C)	Bulk
54-98-052	7-Way Round Pin to 4-Way Flat (Photo C)	Bagged
767940	7-Way Blade to 5-Way Flat (Photo D)	Clam
007257	7-Way Blade to 5-Way Flat, 6" Wire (Photo E)	Clam
707250	7-Way Blade to 5-Way Flat, 18" Wire (Photo F)	Clam
50-98-051	7-Way Blade to 6-Way Round Pin (Auxiliary in Center) (Photo G)	Bulk
54-98-051	7-Way Blade to 6-Way Round Pin (Auxiliary in Center) (Photo G)	Bagged

Standard Vehicle/Trailer Adapters - Step - Up Style

Part No.	Description	Packaging
51-20036	4-Way Flat to 5-Way Flat (Photo A)	Clam

Dual Port Vehicle/Trailer Adapters - Step - Up Style

Part No.	Description	Packaging
20144	4-Way Flat to 4-Way Flat and 7-Way Blade (Photo A)	Clam
20143†	4-Way Flat to 4-Way Flat and 6-Way Round (Photo B)	Clam

VEHICLE/TRAILER COILED WIRE JUMPERS

Environmentally sealed 16 gauge coiled wire prevents tangling. Attractive marine yellow, no fade color. 7-Way mates with OE style 7-way blade connectors. 5-way mates with either a 4-way or 5-way flat connector.

5-WAY TO 5-WAY COILED WIRE JUMPER

Part No.	Description	Packaging
787206	5-Way Coiled Jumper w/4 Ft. Cable (5-Way Flat Car and Trailer Ends)	Bulk
787194	5-Way Coiled Jumper w/4 Ft. Cable (5-Way Flat Car and Trailer Ends)	Clam

7-WAY TO 5-WAY COILED WIRE JUMPERS

Part No.	Description	Packaging
787207	7-Way Trailer to 5-Way Flat Car End Coiled Jumper w/4 Ft. Cable	Bulk
787195	7-Way Trailer to 5-Way Flat Car End Coiled Jumper w/4 Ft. Cable	Clam
787208	7-Way Trailer to 5-Way Flat Car End Coiled Jumper w/8 Ft. Cable	Bulk
787196	7-Way Trailer to 5-Way Flat Car End Coiled Jumper w/8 Ft. Cable	Clam

† = Available while supplies last.



4, 5, 6 AND 7-WAY ADAPTERS

- Allows convenient connection to multiple trailers
- Simple plug-in installation

Standard Vehicle Adapters

Part No.	Description	Packaging
118700	6-Way Round Pin To 4-Flat Adapter	Clam
118700-050	6-Way Round Pin To 4-Flat Adapter (50 Pack)	Boxed
118702	7-Way Flat Pin To 4-Flat Adapter	Clam
118702-050	7-Way Flat Pin To 4-Flat Adapter (50 Pack)	Boxed
118709	7-Way Round Pin To 4-Flat Adapter	Clam
118710	7-Way European Style Round Pin to 4-Flat Adapter	Clam
118704	7-Way To 6-Way Adapter, Electric Brakes To Outer Pin (S)	Clam
118704-050	7-Way To 6-Way Adapter, Electric Brakes To Outer Pin (S) (50 Pack)	Boxed
118708	7-Way To 6-Way Adapter, Electric Brakes To Center Pin (A)	Clam
118708-050	7-Way To 6-Way Adapter, Electric Brakes To Center Pin (A) (50 Pack)	Boxed
118703	7-Way To 5-Flat Adapter	Clam
20136	4-Flat To 5-Flat Adapter	Clam
118032	4-Flat To 4-Flat Universal Adapter	Bagged
118601	4-Flat Knockout Adapter	Clam



Vehicle Adapter for Vehicles with a Lamp Out Indicator Module Towing a Trailer with LED Lights

Part No.	Description	Packaging
20141	7-Way Flat Pin To 5-Flat Adapter w/LED Lamp Out By-Pass	Clam
20142	7-Way Flat Pin to 7-Flat Pin Adapter w/LED Lamp Out By-Pass for European Vehicles	Clam



7-WAY TO CIGARETTE ADAPTER

- Provides 12v power at rear of vehicle for travel accessories
- Ideal for power inverter hook-up
- Great for tailgating

Part No.	Description	Packaging
118019	7-Way to Cigarette Lighter Plug Adapter	Clam





78007

7-WAY TO 4-WAY RETRACTABLE WIRING ADAPTER

- Converts 7-way round blade connector to standard 4-way flat connector
- Adjust length up to 42", no wires dragging on the ground
- Retractable 4-way flat car end plug connects with standard 4-way flat trailer end plug
- Adapts to factory 7-way blade receptacle
- Protects & stores when not in use



Plug & Play Installation

Part No.	Description	Packaging
78007	7-way Round Blade to 4-way Flat	Open Plastic Shroud



78118

7-WAY BLADE TO 4-FLAT W/LED CIRCUIT TESTER

- Easily adapt OEM 7-way blade connector to either 5-flat or a 4-flat connector, Patent pending
- Instantly checks electrical circuit for connectivity
- Displays connectivity using high visibility LEDs
- Attached dust cover included to keep terminals clean when not towing a trailer

Part No.	Description	Packaging
78118	7-Way Blade to 4 or 5-Flat w/LED Circuit Tester	Open Plastic Shroud



78117

7-WAY TO 4-WAY WITH TOW-GLO

- Easily adapt OEM 7-way blade connector to basic 4-flat connector
- Glows BLUE when tail light circuit is activated assisting on seeing connection at night-time
- Attached dust cover included to keep terminals clean when not towing a trailer

Part No.	Description	Packaging
78117	7-Way Blade to 4-Flat w/Tow-Glo	Open Plastic Shroud



20321

6-WAY AND 7-WAY ELECTRICAL ADAPTERS

- Used to convert any trailer wiring component, T-One® or Taillight Converter with a 4-Flat Trailer End Connector to a 6 or 7-Way Round Connector
- For simple mounting, choose 6 & 7-Way Mounting Box Part Numbers 118156, 118157 or 118159 (sold separately)



20125

Part No.	Description	Packaging
20320	4-Flat To 6-Way Round Pin Connector	Clam
20320-012	4-Flat To 6-Way Round Pin Connector (12 Pack)	Bulk
20321	4-Flat To 7-Way Flat Pin Connector - Plastic	Clam
20321-012	4-Flat To 7-Way Flat Pin Connector - Plastic (12 Pack)	Bulk
20322	4-Flat To 7-Way Flat Pin Connector - Metal	Clam
20125	4-Flat To 7-Way Flat Pin U.S. Car Connector - Plastic	Clam



118799

7-WAY PRE-WIRED ADAPTERS

- Used to convert any trailer wiring component, T-One® or Taillight Converter with a 4-Flat Trailer End Connector to a 7-Way Round Connector. Each kit includes 20' of wire.
- For simple mounting, choose 7-Way Mounting Box Part Numbers 118156, 118157 or 118159 (sold separately)

Part No.	Description	Packaging
118799	7-Way Flat Pin Connector w/ Pre-wired Brake Wire	Clam



118607

BRAKE MATE™ KIT - 7-WAY PRE-WIRED ADAPTERS

Includes all necessary parts required to completely install all brake controls. No other parts are necessary. Each BRAKE MATE™ KIT includes:

- Pre-wired 7-way round connector
- Scotch locks (5 pcs.)
- 4-Flat trailer end
- Ring connectors (7 pcs.)
- Heavy-Duty flasher
- Self tapping screws (8 pcs.)
- Heavy-Duty breakers (2 pcs.)
- Tie straps (6 pcs.)
- For simple mounting, choose 7-Way Mounting Box Part Numbers 118156, 118157 or 118159 (sold separately)

Part No.	Description	Packaging
118607	7-Way Flat Pin Brake Mate™ Kit	Clam

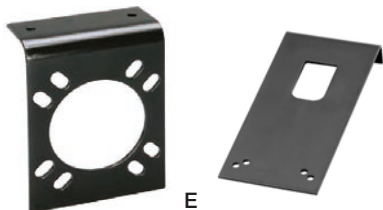
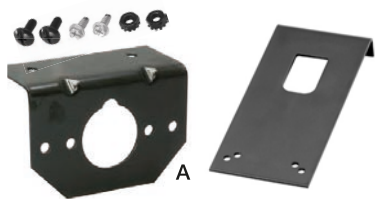

118132

CAR END MOUNTING BRACKETS

Heavy duty plated steel brackets. Features reinforcing beads or flanges for strength. The Black plated model can blend in with the black connector and black hitch for clean consistent finish. Combination brackets have a black, powder coat finish and are formed from 16 gauge steel for strength and durability. Combination brackets are for use with Bargman branded 4-Way and 5-Way Flat connectors.

4-Way Flat Car End Connector Mounting Brackets

Part No.	Description	Packaging
54-18137	4, 5 and 6-Way Round Black Mounting Bracket w/Screws and Nuts (Photo A)	Clam

5-Way Flat Car End Connector Mounting Bracket

Part No.	Description	Packaging
54-20045	5-Way Flat Black Mounting Bracket (Photo B)	Bagged
54-18137	4, 5 and 6-Way Round Black Mounting Bracket w/Screws and Nuts (Photo A)	Bagged

6-Way Car End Connector Mounting Brackets

Part No.	Description	Packaging
54-18137	4, 5 and 6-Way Round Black Mounting Bracket w/Screws and Nuts (Photo A)	Bagged

7-Way Car End Connector Mounting Brackets

Part No.	Description	Packaging
50-77-070*	7-Way Bracket for Car End (Photo C)	Bulk
50-77-071*	7-Way Black Bracket for Car End (Photo D)	Bulk
54-77-071*	7-Way Black Bracket for Car End (Photo D)	Bagged
54-20012	7-Way US Car Black Mounting Bracket w/Screws and Nuts (Photo E)	Bagged

Combination Connector Mounting Brackets

Part No.	Description	Packaging
50-77-075†	7-Way and 5-Way Flat Mounting Bracket (Photo F)	Bulk
54-77-075	7-Way and 5-Way Flat Mounting Bracket (Photo F)	Bagged

*NOTE: 50-77-070, 50-77-071, 54-77-071, 118138, 118138-010 brackets only fit the following Car End Connectors:
 Bargman 7-Way Super Sealed Car Ends with Cable
 Bargman 7-Way Thermo-Plastic or Metal Car End Connectors
 Bargman 90° 7-Way Pre-Wired Cables

4-WAY AND 6-WAY MOUNTING BRACKET

Part No.	Description
118132	Mounting Bracket for 4 & 6-Way Round Connectors (does not include fasteners)

† = Available while supplies last.

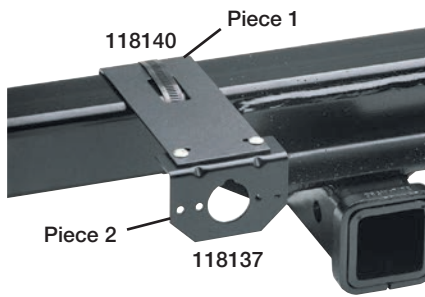

4, 5, 6 AND 7-WAY CONNECTOR MOUNTING BRACKETS

Bargman's line of mounting brackets allows for installation of electrical wiring plugs on vehicles without damage to bumpers or fascia trim. Attachment brackets are designed to attach above or below receiver cross tube with hose clamp.



ATTACHMENT BRACKETS (PIECE 1 OF 2)

- Attaches to cross tube of hitch

Part No.	Description	Packaging
118136	Attachment Bracket For 6 & 7-Way Round Connectors, Includes Clamp (Piece 1 Of 2, Long Bracket)	Clam
118140	Attachment Bracket For 4-Flat, 5-Flat, 4-Way & 5-Way Round Connectors, Includes Clamp (Piece 1 Of 2, Short Bracket)	Clam

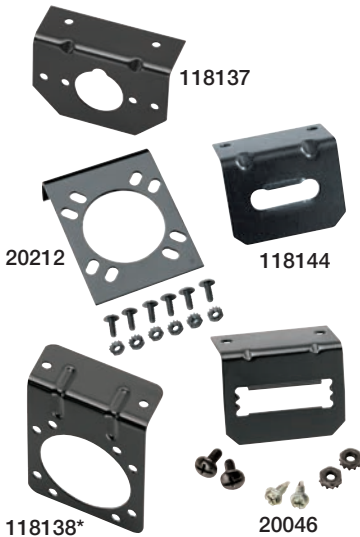

MOUNTING BRACKETS (PIECE 2 OF 2)

- Mounts electrical connector to attachment bracket
- Includes screws and nuts
- Attractive point-of-purchase packaging

Part No.	Description	Packaging
118137	Mounting Bracket For 4, 5 & 6-Way Round Connectors, (Piece 2 Of 2)	Clam
118137-010	Mounting Bracket (10 Pack)	Bulk
118138*	Mounting Bracket, (Piece 2 Of 2)	Clam
118138-010*	Mounting Bracket (10 Pack)	Bulk
118144	Mounting Bracket For 4-Flat Connectors, (Piece 2 Of 2)	Clam
118144-010	Mounting Bracket (10 Pack)	Bulk
20212	Mounting Bracket For 7-Way Us Car Connectors, (Piece 2 Of 2)	Clam
20212-010	Mounting Bracket (10 Pack)	Bulk
20046	Mounting Bracket For 5-Flat Connectors, (Piece 2 Of 2)	Clam

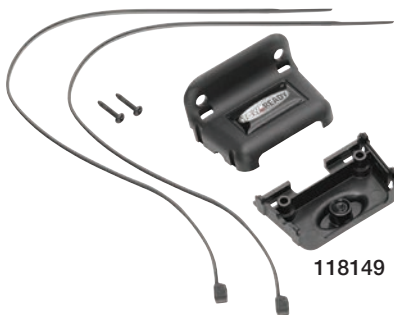

4-WAY FLAT CAR END CONNECTOR MOUNTING BRACKETS

Part No.	Description	Packaging
118149	4-Way Flat Universal Mounting Bracket	Clam
118149-010	4-Way Flat Universal Mounting Bracket (10 pack)	Clam

*NOTE: 50-77-070, 50-77-071, 54-77-071, 118138, 118138-010 brackets only fit the following Car End Connectors:
 Bargman 7-Way Super Sealed Car Ends with Cable
 Bargman 7-Way Thermo-Plastic or Metal Car End Connectors
 Bargman 90° 7-Way Pre-Wired Cables



6-WAY AND 7-WAY PLUG HOLDER

This holder is designed to house your 6-way or 7-way trailer end connector safely out-of-the-way when disconnected from the tow car. Universal holder will accommodate either die cast, steel, plastic or molded trailer ends. Black molded plastic holder mounts on the jackpost with provided cable-ties or the attached adhesive strip and can be mounted on any flat surface with provided screws.

Part No.	Description	Packaging
50-98-003	6-Way and 7-Way Plug Holder	Bulk
54-98-003	6-Way and 7-Way Plug Holder	Bagged



6-WAY AND 7-WAY CONNECTOR HOLDER

- Securely stores 6 and 7-Way Trailer Connectors when not in use
- Mount to tongue jack or trailer frame

Part No.	Description	Packaging
118152	6-Way and 7-Way Trailer Connector Holder	Bagged



4-FLAT CONNECTOR STORAGE BOX & COVERS

- Neatly stores 4-Flat and 5-Flat connectors
- Easily installs with cable ties or screws (included)
- Weatherproof construction

Part No.	Description	Packaging
118145	Connector Storage Box	Clam

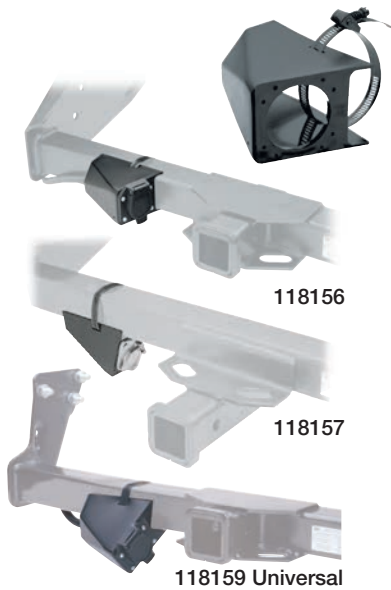

6-WAY AND 7-WAY CONNECTOR MOUNTING BOXES

- No need to disconnect existing wiring
- No drilling
- Mounts with hose clamp included
- Corrosion free
- High impact plastic
- Fits all standard & U.S. car 7-way connectors

Part No.	Description	Packaging
118156	6-Way and 7-Way Connector Mounting Box For Hitches w/2-1/2" Sq. Cross Tubes	Display Box
118156-010	6-Way and 7-Way Connector Mounting Box (10 Pack)	Boxed
118157	6-Way and 7-Way Connector Mounting Box For Hitches w/3" Sq. Cross Tubes	Display Box
118157-010	6-Way and 7-Way Connector Mounting Box (10 Pack)	Boxed
118159	6-Way and 7-Way Connector Mounting Box With Universal Fit For Both Square And Round Tube Hitches	Display Box
118159-010	6-Way and 7-Way Connector Mounting Box (10 Pack)	Boxed

JUNCTION / BREAKER BOXES

Provide a fast, simplified way of connecting wires from the trailer connector to the trailer wiring. The box, complete with 5 wire enter/exit ports, includes hardware, rubber grommets, and features external mounting flanges.

Dimensions: 3 1/4" x 6 1/2" x 2 1/4"



Part No.	Description	Packaging
14-715810	Junction Box	Bulk
787535	Junction Box	Bagged

NOTE: Most Bargman 7-way cable products meet UL standards and are appropriately marked. If a non-UL listed cable will be used to connect tow vehicles to trailers capable of housing or transporting live occupants, Horizon Global recommends the use of a wiring Junction Box. This will provide a simplified method of connecting wire leads from the trailer connector to the UL listed trailer wiring.



TOW VEHICLE WIRING COMPONENTS HEAVY DUTY FLASHERS & RELAYS

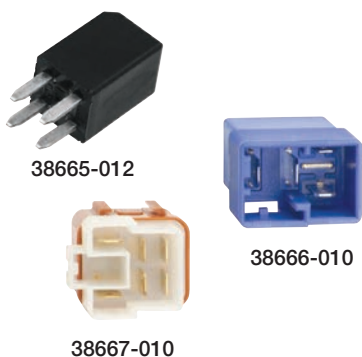

Part No.	Description	Packaging
38665-012	4 Terminal Relay, 12 Volt, 2007-Up Chevrolet Equinox, Pontiac Torrent & Suzuki XL-7/2008-Up Ford Escape, Mazda Tribute & Mercury Mariner (12-pack)	Bagged
38666-010	4 Terminal Relay, Small, 12 Volt, 2004-Up Infiniti QX56, Nissan Armada & Titan/2005-Up Nissan Frontier, Pathfinder & Xterra/2009-Up Suzuki Equator (10-pack)	Bagged
38667-010	6 Terminal Relay, Large, 12 Volt, 2004-Up Infiniti QX56, Nissan Armada & Titan/2005-Up Nissan Frontier, Pathfinder & Xterra/2009-Up Suzuki Equator (10-pack)	Bagged

HARDWARE COMPONENTS

Assortment of hardware components designed specifically for the trailer industry.



Part No.	Description	Packaging
104429	Clip, Plastic Wire, Adhesive Back (1,000 pack)	Bulk
002802	Clip, Metal Wire (1,000 pack)	Bulk
002805	Nut, Wire (Large, 14-16 gauge) (1,000 pack)	Bulk
002806	Tap, White Wire, Double Leads (500 pack)	Bulk
002807	Tap, Blue Wire, Single Leads (500 pack)	Bulk

TERMINALS AND CONNECTORS

Part No.	Description	Packaging
20034-025	Perm-A-Seal [®] Butt Connectors, 14-16 gauge, blue (25 pack)	Bagged
20035-025	Perm-A-Seal [®] Butt Connectors, 10-12 gauge, yellow (25 pack)	Bagged

* Perm-A-Seal[®] brand or comparable substitute

CIRCUIT BREAKERS

Used in 6, 12 and 24V DC applications. Automotive, R.V., air conditioners, battery chargers, any application requiring over-current protection. Non-corrosive molded cover eliminates grounding when operating against a fault line. Includes mounting bracket and installed nuts and washers.



Part No.	Description	Packaging
7010A	15 Amp Circuit Breaker	Bulk
7011A	20 Amp Circuit Breaker	Bulk
7012A	30 Amp Circuit Breaker	Bulk
7013A	40 Amp Circuit Breaker	Bulk
7022A	50 Amp Circuit Breaker	Bulk
7010A-S	15 Amp Circuit Breaker	Clam - Tekonsha
7011A-S	20 Amp Circuit Breaker	Clam - Tekonsha
7012A-S	30 Amp Circuit Breaker	Clam - Tekonsha
7013A-S	40 Amp Circuit Breaker	Clam - Tekonsha
7022A-S	50 Amp Circuit Breaker	Clam - Tekonsha

ELECTROTEK[®] NON-CONDUCTIVE DIELECTRIC SILICONE COMPOUND

A dielectric compound used with electrical connections. Prevent voltage loss from arcing and protect contacts from corrosion. Suppresses radio frequency interference, dissipates heat, insulates trailer wiring connectors and seals out moisture. Effective for automotive, RV and marine electrical applications. Non-water soluble. 3 oz. tube.



Part No.	Description	Packaging
7200	ElectroTek	Bulk
7200P	ElectroTek	Clam

DIELECTRIC GREASE

Using dielectric grease on electrical connectors helps prevent corrosion and increases reliability.



Part No.	Description	Packaging
11755	Dielectric Grease, 2 oz. tube	Boxed

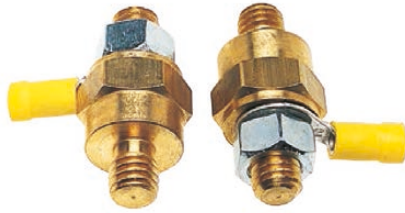

BATTERY POST ADAPTER

Battery Post Adapter for General Motors Side Post Batteries. Allows stud for attaching accessories wires.

Part No.	Description	Packaging
3194-S	Battery Post Adapter	Clam Shell - Tekonsha



BATTERY ISOLATORS

Cadmium plated isolator with terminal nuts and lock-washers. 3 terminal isolator for metal frame ground systems, 4 terminal has insulated ground terminal for use with fiberglass or other non-conductive materials. Isolates starting battery, provides secondary battery current for auxiliary power and full time charging of both batteries.

Part No.	Description	Packaging
7000	Battery Isolator - 3 Terminal	Bulk
54-98-002	Battery Isolator - 3 Terminal	Bagged
7000-S	Battery Isolator - 3 Terminal	Clam - Tekonsha
7001	Battery Isolator - 4 Terminal	Bulk
54-98-004	Battery Isolator - 4 Terminal	Bagged
7001-S	Battery Isolator - 4 Terminal	Clam Shell - Tekonsha



BATTERY ISOLATION SOLENOID

Battery isolation solenoids are used to switch the auxiliary 12v feed off when the ignition is off.

Part No.	Description	Packaging
118665	Battery Isolation Solenoid, 3 Pole, 12 Volt (Chassis Ground)	Clam



6562



767941



6565



8010

7585



20114



20115



20116



20117



40376



3808



20145

ELECTRICAL TESTERS

Plug these testers into any car connector and you will have an instant test of running light circuits. Features LED display to show completed circuit for the running lights, left turn signal and right turn signal. Auxiliary and electric brake circuit are included on the 6-way tester and auxiliary, electric brake and battery charge are included with the 7-way tester. One piece units with internal ground. Proper installation and set-up of a brake control, when a trailer is not readily available, is possible with the 7-way tester.

Current Monitor testing device is designed to assist in determining whether a tow vehicle's 7-way blade car end connector has been wired properly. (Current Monitor is an excellent diagnostic tool for installation, setup and troubleshooting of electric trailer brake controls.)

The Trailer Tester is designed to help you quickly identify problems in the wiring of the trailer. This is done by testing the Left Turn, Right Turn, Tail/Marker, Brake and Back Up circuits on the trailer. The tester indicates approximate amount of current in each circuit. It will also test the voltage of the external battery connected to the trailer charge circuit (i.e. trailer battery).

Brake Control Bench Tester is a test device designed to determine if a brake control is working properly. Checks brake control output, independent of vehicle wiring. Simulates many fault conditions including open ground, short circuit, open load and more.

Part No.	Description	Packaging
767941	4-Way Tester w/LED Display	Clam
6562	7-Way Blade Tester and Trailer Emulator w/LED Display	Clam
54-6562	7-Way Blade Tester and Trailer Emulator w/LED Display	Bagged
767943	7-Way Blade Tester and Trailer Emulator w/LED Display	Clam
6565	Current Monitor	Bulk
8010	Trailer Tester, Includes Charger	Bulk
7585	Brake Control Bench Tester	Bulk

CIRCUIT TESTERS

Part No.	Description	Packaging
40376	Circuit Tester	Clam
3808	Economy Circuit Tester	Clam
20114	4-Flat Circuit Tester	Clam
20115	5-Flat Circuit Tester	Clam
20116	6-Way Circuit Tester	Clam
20117	7-Way Circuit Tester	Clam
20145	LED Circuit Tester	Clam
20145-010	LED Circuit Tester (10 pack)	Clam

TEKONSHA® LIFE IS A JOURNEY STOP OFTEN



BRAKE CONTROLS

ELECTRONIC TRAILER BRAKE CONTROLS

Tekonsha® Prodigy® RF.....	3
Tekonsha® P3®.....	4
Tekonsha® Prodigy® P2.....	4
Tekonsha® Primus™ IQ.....	5
Tekonsha® Voyager®.....	5
Reese® Brakeman® IV.....	6
Reese® Brakeman® Ultra.....	6
Reese® Brakeman® Compact.....	6
Draw-Tite® I-Stop™ IQ.....	7
Draw-Tite® I-Command™.....	7
Draw-Tite® Activator® IV.....	8
Draw-Tite® Activator® III.....	8
Draw-Tite® Activator®.....	8
Draw-Tite® Pilot®.....	9
Draw-Tite® POD™.....	9

BRAKE CONTROL WIRING

Brake Mate Kits.....	11
Brake Control Wiring Harnesses.....	12
Brake Control Wiring Harness Application Guide.....	13-14

BRAKE CONTROL ACCESSORIES

Clip / Pivot Mounts.....	10
Traditional Bracket Mounts.....	10
Replacement Wiring Harnesses.....	10
Pulse Preventer.....	10



NEW PRODUCTS

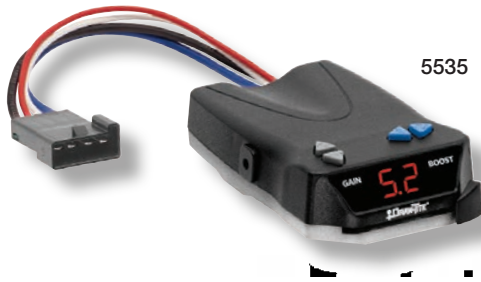

I-COMMAND™ BRAKE CONTROL

- Proportional brake control
- Diagnostics features incorporated in LED display



BRAKE CONTROL WIRING HARNESSES

- Available in 1-plug or 2-plug styles
- 2-plug units are designed for a simple connection into vehicle's built-in port

FEATURED PRODUCTS

PRODIGY® P2



90885

PRODIGY® P2 BRAKE CONTROL

- Self leveling
- Reverse battery protection for both vehicle and breakaway

PRIMUS™ IQ



90160

PRIMUS™ IQ BRAKE CONTROL

- Works proportionally in reverse
- Digital display shows voltage to trailer during braking

PRODIGY® RF

PROPORTIONAL TRAILER MOUNTED BRAKING SYSTEM



90250

PRODIGY® RF BRAKE CONTROL

- Trailer mounted
- Plugs into 7-way, no need for dash mounting

F3



90195

P3® BRAKE CONTROL

- Electric or electrical over hydraulic trailer brake mode selection
- 5 storable setting options



PRODIGY® RF

The perfect shared-trailer solution. If you take to the road with multiple vehicles, there's really only one solution: PRODIGY® RF.

Benefits of the Prodigy® RF:

- User does not need a dash mounted, hard wired brake control
- True proportional trailer braking, forward or reverse
- Trailer braking power supplied via 7-Way Connector from the vehicle
- Suitable for use on any trailer with up to 3 braking axles

In the Tow Vehicle (Hand Held unit):

- Wireless communication between the remote hand unit and trailer mounted power module eliminates the need for under dash wiring
- Easy to see LED display for trailer brake voltage, power output and diagnostics

- Easy to use remote hand control; includes the Prodigy "Boost" system to allow for different levels of customized braking
- Unit provides continual diagnostic scanning with a visual warning display
- Hand held unit plugs into any standard 12 volt power accessory adaptor
- Hand held unit has a limited 5 year warranty



On the Trailer (Power Module Unit):

- Power module uses standard RV Blade style (Bargman) 7-Way truck and trailer connectors
- Trailer Power Module is watertight and is powered through 7-way cable from the tow vehicle.
- Multiple mounting options on the tongue or front of the trailer
- Trailer mounted power module has a limited 15 year warranty (limited 1 year warranty on cord)

Part No.	Description	Packaging
90250	Prodigy® RF Trailer Mount Brake Control w/Hand Held Unit	Display Box
90251	Prodigy® RF Remote Hand Held Unit, Replacement Part	Clam



90195



NOTE: Plug & Play feature allows quick and easy connection. It adapts to all Horizon Global 2-Plug vehicle specific brake control wiring harnesses.

P3®

Taking innovation to a whole new level. P3; the industry's most advanced electric trailer brake control.

A true proportional braking system, P3 has several added features, making it the new standard for electric trailer brake controls.

- 5 storable setting options for pulling different trailers or preferences of multiple drivers
- A distinct, easy-to-read LCD display with multiple screen color options
- “Up-Front” controls provide easy access to all P3 features
- Easy to understand diagnostics show output current, battery/brake/output voltage
- A “flashing red” warning system alerts user to “No Trailer Brake” situations
- Select Electric over Hydraulic or Electric trailer brake mode
- Numerous mounting options - including 360 degree vertical rotation
- Screen information display in English, French or Spanish
- “The Original Boost” feature allows for different levels of customized braking
- Compact, dash-hugging design
- Integrated Plug & Play port for 2-plug adapters
- Snap-in mounting clip allows user to remove and store the control when not in use
- Electric trailer brake control for up to 4 braking axles
- Limited Lifetime Warranty



Part No.	Description	Packaging
90195	P3® Proportional Electronic Trailer Brake Control	Display Box

PRODIGY® P2



90885



PRODIGY® P2

Advanced Intelligence

- Reverse battery protection for both vehicle and breakaway
- Designed to work with electric over hydraulic brake systems
- Numerous mounting options – including 360 degree vertical rotation
- Digital display depicts voltage delivery to trailer during braking
- No level adjustment necessary – it adjusts itself to varying terrain as you drive
- Great for backing into tough spots! Works proportionally in reverse - with the ability to disable when not needed
- Produces stops that are in proportion to vehicle's deceleration rate
- “Boost” feature gives users the ability to apply more initial trailer braking power when towing heavier trailers
- Continual diagnostics check for proper connection, shorted magnet conditions and much more
- Integrated Plug & Play port for 2-plug adapters
- Pocket-mount allows user to remove and store the control when not in use
- Electric trailer brake control for up to 4 braking axles
- Limited Lifetime Warranty



Part No.	Description	Packaging
90885	Prodigy® P2 Proportional Electronic Trailer Brake Control	Display Box



PRIMUS^{IQ}



90160



PRIMUS™ IQ

The smarter braking solution. Primus IQ is a totally proportional electric trailer brake control.

This easy-to-set system allows the driver maximum flexibility when determining how the trailer should respond to a braking event. Snap-in dash mounting clip and removable electrical connector allow the unit to be quickly stored (or moved to another vehicle) when not in use.

- Works proportionally in reverse
- No level adjustment necessary, adjusts to varying terrain as you drive
- Digital display shows voltage to trailer during braking
- “The Original Boost” feature allows for customized braking
- Integrated Plug & Play port for 2-plug adapters
- Diagnostic features incorporated in LED display
- Electric trailer brake control for up to 3 braking axles
- Snap-in mounting clip allows user to remove and store the control when not in use
- Limited Lifetime Warranty

Part No.	Description	Packaging
90160	Primus™ IQ Proportional Electronic Trailer Brake Control	Display Box

VOYAGER[®]



9030



VOYAGER[®]

The Voyager incorporates Tekonsha’s patented braking sensor and is the best value you’ll find for smooth and secure trailer braking.

Compact size and features, like a bicolored LED brake monitor (to assure a complete connection to trailer brakes and give an indication of relative braking power being applied) make the Voyager extremely versatile. Voyager minimizes interference with tow vehicle electrical systems, has a broad setting range and is compatible with most any vehicle.

- Broad control range makes setting quick and easy
- As braking power is applied, the LED changes color gradually from green (completed circuit) to red, to indicate relative braking power
- Advanced electronics minimize false braking for smoother ride
- Electric trailer brake control for up to 4 braking axles
- Plug & Play feature allows quick and easy connection
- Limited 5 year warranty

Part No.	Description	Packaging
9030	Voyager [®] Proportional Electronic Trailer Brake Control	Display Box

NOTE: Plug & Play feature allows quick and easy connection. It adapts to all Horizon Global 2-Plug vehicle specific brake control wiring harnesses.

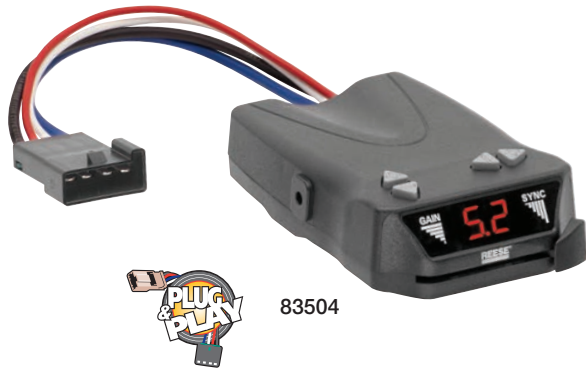

83504

BRAKEMAN® IV

- 1 to 4 axle trailers
- Digital output indicator
- Small, compact design
- Up-front push buttons for Sync and Output
- Diagnostics for Overload, Open Ground
- Short Circuit Protected
- Mounts in any direction
- No leveling required
- Mounting hardware included
- Smooth and simple installation
- Plug & Play feature allows quick and easy connection
- Attractive point-of-purchase display packaging
- Lifetime limited warranty



Part No.	Description	Packaging
83504	Brakeman® IV Electronic Brake Control	Clam

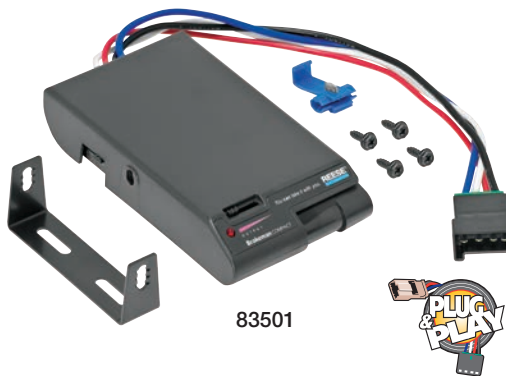

83501

BRAKEMAN® COMPACT

- 1 & 2 axle trailers
- Illuminated LED output indicator
- Slide adjustment output control
- Plug & Play feature allows quick and easy connection
- Limited 5 year warranty



Part No.	Description	Packaging
83501	Brakeman® Compact Electronic Brake Control	Clam

Note: Not recommended for use with BMW X5 Sport Utility Vehicles

NOTE: Plug & Play feature allows quick and easy connection. It adapts to all Horizon Global 2-Plug vehicle specific brake control wiring harnesses.



i-Stop™ IQ



20191



I-STOP™ IQ

A totally proportional electric trailer brake control, the Draw-Tite I-Stop™ IQ is self-leveling so no level adjustment is necessary.

Utilizing primary sensor technology the IQ now includes the “Boost” feature that gives users the ability to apply more initial trailer braking when towing heavier trailers. It works proportionally in reverse for backing into tough spots and includes a snap-in dash mounting clip and removable electrical connector that allows the unit to be quickly stored when not in use. You will appreciate the digital readout depicting a secure electrical connection, amount of voltage delivery to the trailer brakes and diagnostic features incorporated in the LED display. Capable of handling up to 3 axle trailers.

- Integrated Plug & Play port for 2-plug adapters
- Self-diagnostics features will illuminate LED readout when issues occur
- Includes a “Boost” feature
- Works proportionally in reverse
- Snap-in dash mounting clip and hardware included
- Digital LED readout
- Snap-in mounting clip allows user to remove and store the control when not in use
- Limited Lifetime Warranty



Part No.	Description	Packaging
20191	I-Stop™ IQ Proportional Electronic Trailer Brake Control	Display Box

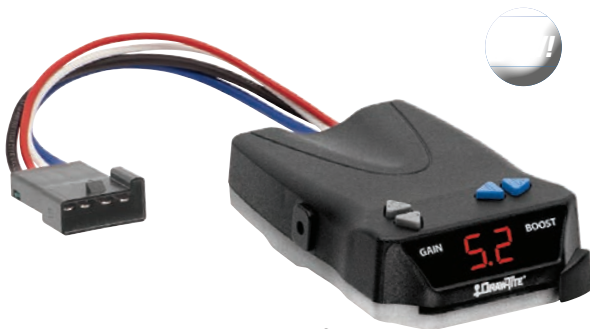

5535



I-COMMAND™

Exclusive to Draw-Tite

A compact, proportional brake control that requires no leveling with “up-front” buttons for easy access to Output and Boost. diagnostic features incorporated in the LED display.

- 1-4 axle trailers
- Proportional Brake Control
- Boost feature gives the ability to apply more initial trailer braking
- Reverse battery protection
- No level adjustment necessary
- Diagnostics features incorporated in LED Display
- Plug & Play feature allows for quick and easy connection
- Limited Lifetime Warranty



Part No.	Description	Packaging
5535	I-Command Electronic Brake Control, for 1 to 4 Axle Trailers, Proportional	Clam

NOTE: Plug & Play feature allows quick and easy connection. It adapts to all Horizon Global 2-Plug vehicle specific brake control wiring harnesses.

ACTIVATOR® IV

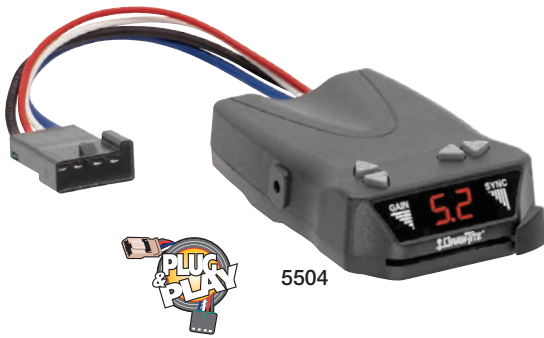

5504

ACTIVATOR® IV

- 1 to 4 axle trailers
- Digital output indicator
- Small, compact design
- Up-front push buttons for Sync and Output
- Diagnostics for Overload, Open Ground
- Short Circuit Protected
- Mounts in any direction
- No leveling required
- Mounting hardware included
- Smooth and simple installation
- Plug & Play feature allows quick and easy connection
- Attractive point-of-purchase display packaging
- Lifetime limited warranty



Part No.	Description	Packaging
5504	Activator® IV Electronic Brake Control	Clam

ACTIVATOR®

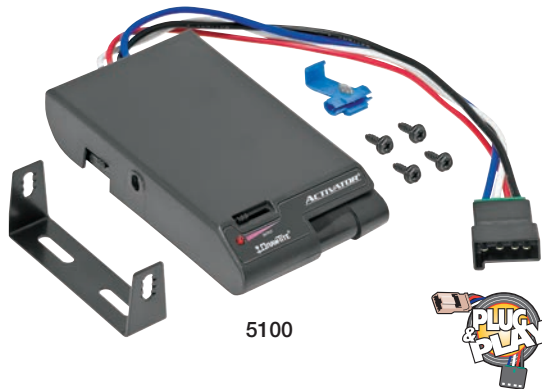

5100

ACTIVATOR®

- 1 & 2 axle trailers
- Illuminated LED output indicator
- Slide adjustment output control
- Plug & Play feature allows quick and easy connection
- Attractive point-of-purchase display packaging
- Limited 5 year warranty



Part No.	Description	Packaging
5100	Activator® Electronic Brake Control	Clam

Note: Not recommended for use with BMW X5 Sport Utility Vehicles

NOTE: Plug & Play feature allows quick and easy connection. It adapts to all Horizon Global 2-Plug vehicle specific brake control wiring harnesses.

† = Available while supplies last.

PILOT®



80550

PILOT®

The Pilot® has just made owning and operating a digital brake control easier than ever.

Because of the flexible mounting options, you are able to mount the Pilot® in any direction. Our microprocessor allows you the ability to read the display even when the Pilot® is mounted upside down. The Pilot's digital display shows voltage output to the brakes with additional protection against short circuit or loss of ground. Capable of handling up to 3 axle trailers.

- Large easy to read dual digital display shows:
 - Properly wired control
 - Voltage output to brakes (vs. a percentage output)
 - Connection to trailer
- Dark smoke lens ideal for direct light applications; performs better than red lens
- Microprocessor allows control to be mounted upside down and still have a readable display
- Protection against short circuit and loss of ground
- Standard mounting bracket included, optional pivot mount available (P/N 5298)
- For use on any 12 volt negative ground system
- Plug & Play feature allows quick and easy connection
- Limited Lifetime Warranty



Part No.	Description	Packaging
80550	Pilot® Electronic Brake Control	Clam



80500

POD™

The POD™ (Power on Demand) is your best choice for 1 or 2 axle trailers, especially when your installation options are limited.

The POD™ can be mounted in any direction, and its unique design features “up-front-easy-access” adjustment controls, even when mounted upside down.

- Power-on LED for a positive tow vehicle-to-trailer connection
- “Up-front” manual over-ride control
- Rugged, easy mount chassis
- Mounting hardware included
- Smooth and simple installation
- Solid state electronics
- Plug & Play feature allows quick and easy connection
- Limited 5 year warranty



Part No.	Description	Packaging
80500	POD™ Electronic Brake Control	Clam

NOTE: Plug & Play feature allows quick and easy connection. It adapts to all Horizon Global 2-Plug vehicle specific brake control wiring harnesses.

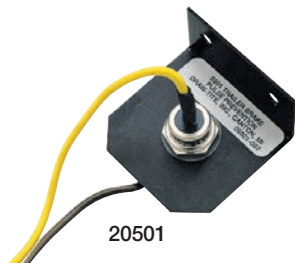

BRAKE CONTROL ACCESSORIES

Clip / Pivot Mounting

Part No.	Application	Description	Pkg
5901TEK	P3 90195	Dash Mounting Clip	Bulk
5904	P3 90195	Dash Mounting Clip Bracket	Bulk
5906	P3 90195	T-Slot Mounting Kit	Bulk
5298	Pilot 80550	Dash Pivot Mounting Kit	Bulk
7686	Prodigy P2 90885	Dash Pocket Mounting Kit	Clam
6927	Primus IQ 90160, I-Stop IQ 20191	Dash Mounting Clip	Bulk

Traditional Bracket Mounting

Part No.	Application	Description	Pkg
7685	Prodigy P2 90885	Mounting Bracket Kit	Clam
5280	Primus IQ 90160, I-Stop IQ 20191, Pilot 80550	Mounting Bracket Only	Bulk
2178	P3 90195, Voyager 9030, POD 80500	Mounting Bracket Kit	Bulk

Replacement Wiring Harness

Part No.	Application	Description	Pkg
7894	P3 90195, P2 90885, Primus IQ 90160, I-Stop IQ 20191, 5520 Activator III, 83520 Brakeman Ultra	30" Pigtail Harness Kit	Clam
20127	P3 90195, P2 90885, Primus IQ 90160, I-Stop IQ 20191, 5520 Activator III, 83520 Brakeman Ultra	12" Pigtail Harness	Clam
20127-012	P3 90195, P2 90885, Primus IQ 90160, I-Stop IQ 20191, 5520 Activator III, 83520 Brakeman Ultra (12 pack)	12" Pigtail Harness	Clam

PULSE PREVENTER

Immunizes against the effects of 4-Way flashers on some brake controls.

Part No.	Description	Packaging
20501	Pulse Preventer	Clam



118607

BRAKE MATE™ KIT

Includes all necessary parts required to completely install all brake controls. No other parts are necessary.

Each Brake Mate™ Kit includes:

- Pre-wired 7-Way round connector
- Heavy duty flasher
- Heavy duty breakers (2 pcs.)
- Self tapping screws (8 pcs.)
- Integrated 4-Flat trailer end
- Tie straps (6 pcs.)
- Scotch locks (5 pcs.)
- For simple mounting, choose 7-Way Mounting Box Part Numbers 118156, 118157
- Ring connectors (7 pcs.) or 118159 (sold separately)

Part No.	Description	Packaging
118607	7-Way Brake Mate™ Kit – Flat Pin	Clam



20505, 20506

BRAKE MATE™ KIT

Part No.	Description	Packaging
20505	Wiring Kit for 1 - 2 Axles Brake Control Systems, Includes 25' 12-2 Duplex Wire, 20 Amp Circuit Breaker and Attaching Terminals	Clam
20506	Wiring Kit for 3 – 4 Axles Brake Control Systems, Includes 25' 10-2 Duplex Wire, 30 Amp Circuit Breaker and Attaching Terminals	Clam



BRAKE CONTROL WIRING HARNESES

All vehicle specific brake control wiring harnesses are available in 1-Plug or 2-Plug styles.

1-Plug units are designed for brake controls manufactured with electrical wiring mounted on the back of the unit, otherwise known as a pigtail. Wiring harnesses must be spliced into the existing pigtail to allow the vehicle specific plug to be installed.

2-Plug units are designed for brake controls that have a wiring port built into the back of the unit. Simply plug the brake control end of the wiring harness into the back of the brake control and the vehicle end into the automobile's port. Brake controls that utilize the 2-plug style of wiring harness will be identified with the Plug & Play logo.

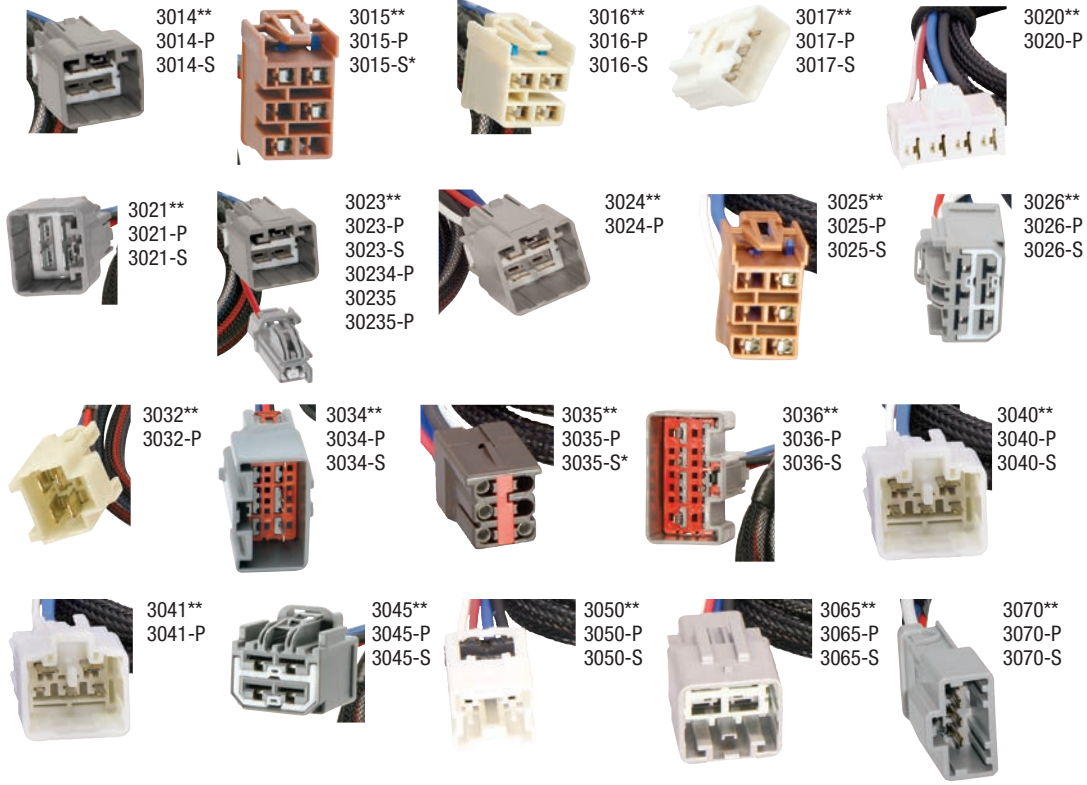

* Clam and also available in bulk 12-pack. (Ex: 3015-S-012) ** Bulk 20-pack.

- BP1 - Under or behind dash, to the left or right of the emergency brake pedal.
- BP2 - Under or behind dash to the left of the steering column and brake pedal.
- BP3 - Under or behind dash to the right of the steering column and brake pedal.
- BP4 - Kick panel area, on the Driver's side.
- BP5 - Under or behind dash, behind the center console.
- BP6 - Under or behind dash on the passenger side, near glovebox.
- BP7 - Centered behind dash between the steering column and the radio.
- BP8 - Under or behind dash to the right of the steering column and brake pedal. Also includes 7-Way adapter kit located at the rear center behind the bumper. This unit complies with all applicable California Regulations.
- BP9 - Includes 7-Way adapter kit located at the rear center behind the bumper. This unit complies with all applicable California Regulations.

VEHICLE SPECIFIC BRAKE CONTROL WIRING HARNESS POSITION



BRAKE CONTROL WIRING HARNESSES APPLICATION GUIDE



MODEL	YEAR	POS	PART NO.	PART NO.	PART NO.
BUICK					
Enclave w/Factory 7-Way	08-16	BP1	3026-S	3026-P	3026
CADILLAC					
Escalade	02	BP1	3025-S	3025-P	3025
Escalade	03-06	BP1	3015-S	3015-P	3015
Escalade	15-16	BP2	3016-S	3016-P	3016
Escalade ESV	03-06	BP1	3015-S	3015-P	3015
Escalade EXT	02	BP1	3025-S	3025-P	3025
Escalade EXT	03-06	BP1	3015-S	3015-P	3015
CHEVROLET					
Avalanche 1500	02	BP1	3025-S	3025-P	3025
Avalanche 1500	03-06	BP1	3015-S	3015-P	3015
Avalanche 2500	02	BP1	3025-S	3025-P	3025
Avalanche 2500	03-06	BP1	3015-S	3015-P	3015
Silverado 1500	99-02	BP1	3025-S	3025-P	3025
Silverado 1500	03-06	BP1	3015-S	3015-P	3015
Silverado 1500	14-16	BP2	3016-S	3016-P	3016
Silverado 1500 (Classic)	07	BP1	3015-S	3015-P	3015
Silverado 1500 HD	01-02	BP1	3025-S	3025-P	3025
Silverado 1500 HD	03-06	BP1	3015-S	3015-P	3015
Silverado 1500 HD (Classic)	07	BP1	3015-S	3015-P	3015
Silverado 2500	99-02	BP1	3025-S	3025-P	3025
Silverado 2500	03-04	BP1	3015-S	3015-P	3015
Silverado 2500 HD	01-02	BP1	3025-S	3025-P	3025
Silverado 2500 HD	03-06	BP1	3015-S	3015-P	3015
Silverado 2500 HD	15-16	BP2	3016-S	3016-P	3016
Silverado 2500 HD (Classic)	07	BP1	3015-S	3015-P	3015
Silverado 3500	01-02	BP1	3025-S	3025-P	3025
Silverado 3500	03-06	BP1	3015-S	3015-P	3015
Silverado 3500 (Classic)	07	BP1	3015-S	3015-P	3015
Silverado 3500 HD	15-16	BP2	3016-S	3016-P	3016
Suburban	15-16	BP2	3016-S	3016-P	3016
Suburban 1500	03-06	BP1	3015-S	3015-P	3015
Suburban 1500 w/Amber Turn Signals	00-02	BP1	3025-S	3025-P	3025
Suburban 2500	03-06	BP1	3015-S	3015-P	3015
Suburban 2500 w/Amber Turn Signals	00-02	BP1	3025-S	3025-P	3025
Tahoe	03-06	BP1	3015-S	3015-P	3015
Tahoe	15-16	BP2	3016-S	3016-P	3016
Tahoe w/Amber Turn Signals	00-02	BP1	3025-S	3025-P	3025
Traverse w/Factory 7-Way	09-16	BP1	3026-S	3026-P	3026
CHRYSLER					
Aspen w/Factory Tow Package	07-09	BP2	3020-S	3020-P	3020
DODGE					
Dakota w/Factory Tow Package	97-10	BP2	3020-S	3020-P	3020
Durango w/Factory Tow Package	98-09	BP2	3020-S	3020-P	3020
Durango w/Factory Tow Package	11-14	BP2	3045-S	3045-P	3045
Ram 1500	95-09	BP2	3020-S	3020-P	3020
Ram 1500	10	BP1	3021-S	3021-P	3021
Ram 2500	95-09	BP2	3020-S	3020-P	3020
Ram 2500	10	BP1	3021-S	3021-P	3021
Ram 3500	95-09	BP2	3020-S	3020-P	3020
Ram 3500	10	BP1	3021-S	3021-P	3021
FORD					
Bronco	94-96	BP3	3035-S	3035-P	3035
E-150 Econoline	92-08	BP3	3035-S	3035-P	3035
E-150 Econoline	09-14	BP7	3034-S	3034-P	3034
E-250 Econoline	92-08	BP3	3035-S	3035-P	3035
E-250 Econoline	09-14	BP7	3034-S	3034-P	3034
E-350 Econoline	92-08	BP3	3035-S	3035-P	3035
E-350 Econoline RV Cutaway, w/Factory Tow Prep Plug	92-08	BP3	3035-S	3035-P	3035
E-350 Econoline Super Duty	09-14	BP7	3034-S	3034-P	3034
E-350 Econoline Super Duty RV Cutaway, w/Factory Tow Prep Plug	09-11	BP7	3034-S	3034-P	3034
E-450 Econoline Super Duty RV Cutaway, w/Factory Tow Prep Plug	03-08	BP3	3035-S	3035-P	3035
E-450 Econoline Super Duty RV Cutaway, w/Factory Tow Prep Plug	09-11	BP7	3034-S	3034-P	3034
E-450 Econoline Super Duty Stripped RV Cutaway, w/Factory Tow Prep Plug	00-02	BP3	3035-S	3035-P	3035
Excursion	00-05	BP3	3035-S	3035-P	3035
Expedition	97-12	BP3	3035-S	3035-P	3035
Expedition	13-14	BP5	3034-S	3034-P	3034
Explorer w/Factory Tow Package	02-16	BP2	3035-S	3035-P	3035
Explorer Sport Trac w/Factory Tow Package	07-10	BP2	3035-S	3035-P	3035



3026

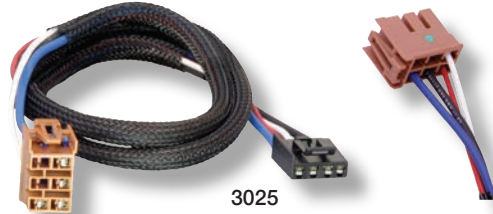

3025

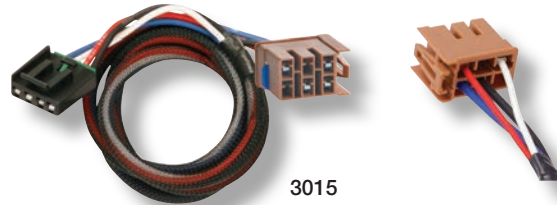

3015

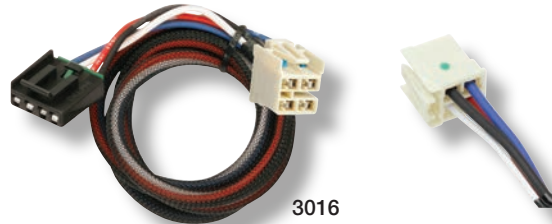

3016



3020



3045



3021

BRAKE CONTROL WIRING HARNESSES APPLICATION GUIDE



MODEL	YEAR	POS	PART NO.	PART NO.	PART NO.
FORD (Continued)					
F-150	94-08	BP3	3035-S	3035-P	3035
F-150	09-16	BP3	3036-S	3036-P	3036
F-150 Heritage	04	BP3	3035-S	3035-P	3035
F-250	94-96	BP3	3035-S	3035-P	3035
F-250 Heavy Duty	97	BP3	3035-S	3035-P	3035
F-250 Styleside	97-99	BP3	3035-S	3035-P	3035
F-250 Super Duty	99-04	BP3	3035-S	3035-P	3035
F-250 Super Duty	05-07	BP5	3065-S	3065-P	3065
F-250 Super Duty	08-16	BP3	3034-S	3034-P	3034
F-350	94-96	BP3	3035-S	3035-P	3035
F-350 Heavy Duty	97	BP3	3035-S	3035-P	3035
F-350 Super Duty	99-04	BP3	3035-S	3035-P	3035
F-350 Super Duty	05-07	BP5	3065-S	3065-P	3065
F-350 Super Duty	08-16	BP3	3034-S	3034-P	3034
F-350 Super Duty Cab & Chassis	05-07	BP5	3065-S	3065-P	3065
F-350 Super Duty Cab & Chassis	08-16	BP3	3034-S	3034-P	3034
F-450 Super Duty	08-16	BP3	3034-S	3034-P	3034
F-450 Super Duty Cab & Chassis	99-04	BP3	3035-S	3035-P	3035
F-450 Super Duty Cab & Chassis	05-07	BP5	3065-S	3065-P	3065
F-450 Super Duty Cab & Chassis	08-16	BP3	3034-S	3034-P	3034
F-550 Super Duty Cab & Chassis	99-04	BP3	3035-S	3035-P	3035
F-550 Super Duty Cab & Chassis	05-07	BP5	3065-S	3065-P	3065
F-550 Super Duty Cab & Chassis	08-16	BP3	3034-S	3034-P	3034
Flex w/Factory Tow Package	09-11	BP2	3035-S	3035-P	3035
Flex w/Factory Tow Package	12-16	BP5	3036-S	3036-P	3036
Windstar w/Factory Tow Package	95-03	BP3	3035-S	3035-P	3035
GMC					
Acadia w/Factory 7-Way	07-16	BP1	3026-S	3026-P	3026
Sierra 1500	99-02	BP1	3025-S	3025-P	3025
Sierra 1500	03-06	BP1	3015-S	3015-P	3015
Sierra 1500	14-16	BP2	3016-S	3016-P	3016
Sierra 1500 (Classic)	07	BP1	3015-S	3015-P	3015
Sierra 1500 HD	01-02	BP1	3025-S	3025-P	3025
Sierra 1500 HD	03-06	BP1	3015-S	3015-P	3015
Sierra 1500 HD (Classic)	07	BP1	3015-S	3015-P	3015
Sierra 2500	99-02	BP1	3025-S	3025-P	3025
Sierra 2500	03-04	BP1	3015-S	3015-P	3015
Sierra 2500 HD	01-02	BP1	3025-S	3025-P	3025
Sierra 2500 HD	03-06	BP1	3015-S	3015-P	3015
Sierra 2500 HD	15-16	BP2	3016-S	3016-P	3016
Sierra 2500 HD (Classic)	07	BP1	3015-S	3015-P	3015
Sierra 3500	01-02	BP1	3025-S	3025-P	3025
Sierra 3500	03-06	BP1	3015-S	3015-P	3015
Sierra 3500 (Classic)	07	BP1	3015-S	3015-P	3015
Sierra 3500 HD	15-16	BP2	3016-S	3016-P	3016
Yukon	03-06	BP1	3015-S	3015-P	3015
Yukon	15-16	BP2	3016-S	3016-P	3016
Yukon w/Amber Turn Signals	00-02	BP1	3025-S	3025-P	3025
Yukon Denali	03-06	BP1	3015-S	3015-P	3015
Yukon Denali w/Amber Turn Signals	01-02	BP1	3025-S	3025-P	3025
Yukon XL 1500	00-02	BP1	3025-S	3025-P	3025
Yukon XL 1500	03-06	BP1	3015-S	3015-P	3015
Yukon XL 1500 Denali	01-02	BP1	3025-S	3025-P	3025
Yukon XL 1500 Denali	03-06	BP1	3015-S	3015-P	3015
Yukon XL 2500	00-02	BP1	3025-S	3025-P	3025
Yukon XL 2500	03-06	BP1	3015-S	3015-P	3015
HONDA					
Pilot w/Factory Tow Package	09-16	BP1	3070-S	3070-P	3070
Ridgeline w/Factory Tow Package	06-14	BP1	3070-S	3070-P	3070
HUMMER					
H2	03-07	BP1	3015-S	3015-P	3015
INFINITI					
QX56	04-13	BP1	3050-S	3050-P	3050
JEEP					
Cherokee	14-16	BP1	3014-S	3014-P	3014
Grand Cherokee w/Factory Tow Package	11-15	BP2	3045-S	3045-P	3045
KIA					
Borrego	09-11	BP4		3032-P	3032
LAND ROVER					
LR3	05-09	BP3	3035-S	3035-P	3035
LR4	10-15	BP3	3035-S	3035-P	3035
Range Rover	05-14	BP3	3035-S	3035-P	3035
Range Rover	15	BP3	3035-S	3035-P	3035



3035

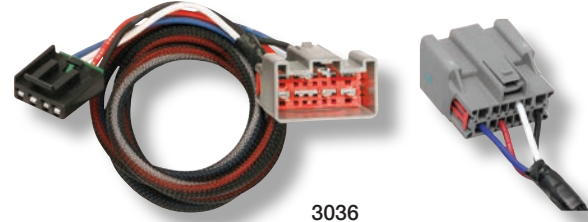

3036

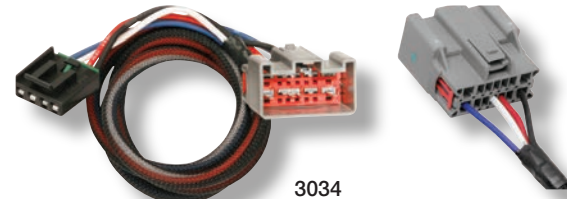

3034



3065



3070



3045



3014

BRAKE CONTROL WIRING HARNESSES APPLICATION GUIDE



MODEL	YEAR	POS	PART NO.	PART NO.	PART NO.
LAND ROVER (Continued)					
Range Rover Evoque	12-16	BP2	3035-S	3035-P	3035
LEXUS					
GX460	10-15	BP4	3040-S	3040-P	3040
GX470	03-09	BP3	3040-S	3040-P	3040
LX470	03-07	BP3	3040-S	3040-P	3040
LX570	08-11	BP3	3040-S	3040-P	3040
LX570	13-15	BP4	3040-S	3040-P	3040
LINCOLN					
Aviator w/Factory Tow Package	03-05	BP6	3035-S	3035-P	3035
Mark LT	06-08	BP3	3035-S	3035-P	3035
MKT w/Factory Tow Package	10-11	BP1	3035-S	3035-P	3035
MKT w/Factory Tow Package	12-15	BP1	3036-S	3036-P	3036
Navigator	98-12	BP3	3035-S	3035-P	3035
Navigator	13-14	BP3	3034-S	3034-P	3034
MERCURY					
Mountaineer w/Factory Tow Package	02-10	BP2	3035-S	3035-P	3035
NISSAN					
Armada	05-15	BP1	3050-S	3050-P	3050
Frontier	05-15	BP3	3050-S	3050-P	3050
NV1500	13-15	BP1	3050-S	3050-P	3050
NV2500	13-15	BP1	3050-S	3050-P	3050
NV3500	13-15	BP1	3050-S	3050-P	3050
Pathfinder	05-16	BP3	3050-S	3050-P	3050
Pathfinder Armada	04	BP1	3050-S	3050-P	3050
Titan	04-16	BP1	3050-S	3050-P	3050
Xterra w/Factory Tow Package	05-15	BP3	3050-S	3050-P	3050
RAM					
1500	11-12	BP1	3021-S	3021-P	3021
1500	13-14	BP3	3023-S	3023-P	3023
		BP8		30234-P	
1500	13-16	BP9		30235-P	30235
1500	15-16	BP2		3024-P	3024
2500	11-12	BP1	3021-S	3021-P	3021
2500	13-14	BP3	3023-S	3023-P	3023
		BP8		30234-P	
2500	13-16	BP9		30235-P	30235
2500	15-16	BP2		3024-P	3024
3500	11-12	BP1	3021-S	3021-P	3021
3500	13-14	BP3	3023-S	3023-P	3023
		BP8		30234-P	
3500	13-16	BP9		30235-P	30235
3500	15-16	BP2		3024-P	3024
Dakota w/Factory Tow Package	11	BP2	3020-S	3020-P	3020
SATURN					
Outlook w/Factory 7-Way	07-09	BP1	3026-S	3026-P	3026
TOYOTA					
4Runner	03-13	BP4	3040-S	3040-P	3040
4Runner	14-16	BP4		3041-P	3041
Land Cruiser	03-11	BP3	3040-S	3040-P	3040
Land Cruiser	13-15	BP3	3040-S	3040-P	3040
Sequoia	03-15	BP4	3040-S	3040-P	3040
Tacoma	07-15	BP4	3040-S	3040-P	3040
Tacoma	16-17	BP7	3017-S	3017-P	3017
Tundra	03-14	BP4	3040-S	3040-P	3040



3041



3040



3017



3024



3050



3023



3032

REESE® THE LEADER IN WEIGHT DISTRIBUTION



WEIGHT DISTRIBUTION SYSTEMS

WEIGHT DISTRIBUTION SYSTEM INFORMATION REESE® WEIGHT DISTRIBUTION

Materials & Testing	3-4	Trunnion Style without Hitch Bar	11
Selection Chart	5	Hitch Bar Selection Chart	11

STRAIT-LINE® SYSTEMS

Strait-Line® Trunnion Bar Hitch	6
Strait-Line® Round Bar Hitch	6

SWAY CONTROL HITCH KITS

Sway Control Hitch Kit with Hitch Bar	7
---	---

STEADI-FLEX™ WEIGHT DISTRIBUTION

Steady-Flex™ Heavy Duty Kits	8
Steady-Flex™ Light Duty Kits	8

TRUNNION STYLE WEIGHT DISTRIBUTION

Trunnion Style without Hitch Bar	9
Trunnion Style with Hitch Bar	9

ROUND BAR STYLE WEIGHT DISTRIBUTION

Round Bar Style with Hitch Bar	10
--	----

WEIGHT DISTRIBUTION KITS

Complete Round Bar Kit	12
Complete Trunnion Style Kit	12
Round Bar RB2	13
Round Bar RB3	13

SWAY CONTROLS

Adjustable Ball Mounts with Hitch Bars	14
Dual Cam High-Performance SC	14
Friction Sway Control	14
Bolt-On Mounting Adapters	14

WEIGHT DISTRIBUTION HITCH BARS

Hitch Bars	15
----------------------	----

WEIGHT DISTRIBUTION ACCESSORIES

Tongue Weight Scale	16
Pole Tongue Adapters	16
Chain Hangers	16
Snap-Up Brackets	16

NEW PRODUCTS



STEADI-FLEX®

STEADI-FLEX™ HEAVY DUTY WEIGHT DISTRIBUTION KITS

- No drill installation
- 14,000 lbs. max GTW

FEATURED PRODUCTS



26002

DUAL CAM HIGH-PERFORMANCE SWAY CONTROL

- Fits most applications
- Integrated cams into the spring bars reduce noise



54998

3215

WEIGHT DISTRIBUTION HITCH BARS

- Angled, extended "T" and deep drops available
- Designed for use in the rise or drop position



6637

WEIGHT DISTRIBUTION SNAP UP BRACKETS

- Rugged positive locking system
- Narrower, for increased frame clearance

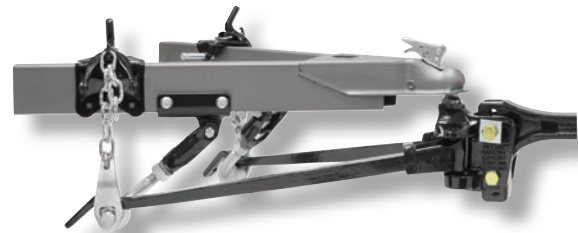

66075

STRAIT-LINE® SYSTEM

- Fully automatic and self-centering
- Easy adjustment of centerline

Add a weight distributing system to provide a more level ride, greater steering and brake control.

The differences are in construction materials, welding, manufacturing processes and hook-up. Adjustment is simple because of the easy-to-operate snap-up brackets that allow spring bar tension to be adjusted by changing links in the support chains. Rather than merely supporting the trailer tongue weight (TW), weight-distributing hitches apply leverage between the towing vehicle and trailer causing the TW to be carried by all axles of the tow vehicle and trailer.

A Weight Distributing Hitch System is composed of four major elements:

1. the hitch receiver
2. the weight distribution kit
3. the hitch ball
4. the sway control (see below)

*They work in unison to provide complete towing system compatibility.

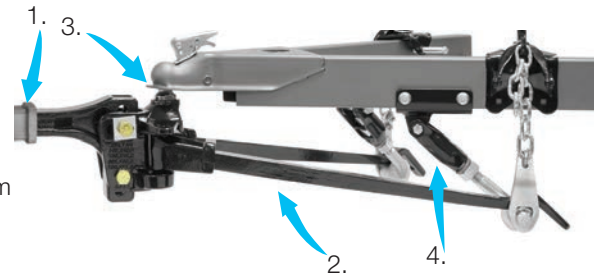

without weight distributing



with weight distribution

Dual Cam HP

Premier Sway Control – Unlike the friction sway control, the Dual Cam HP has the ability to forestall sway from the start in addition to resisting sway once it's begun. Works only when needed and allows free and easy vehicle/trailer interaction. Installs on the trailer and therefore doesn't require adjustment every time the tow vehicle and trailer are hooked up, unless ball mount height angle or the number of working chain links are changed.

- Integrated cams in the spring bars reduce noise
- No U-bolts to conflict with bottle racks or other A-Frame mounted items
- Specific attachment reference points provided
- Simple, easy adjustment of centerline
- Fits more applications
- Improved installation times
- Years of extensive field testing

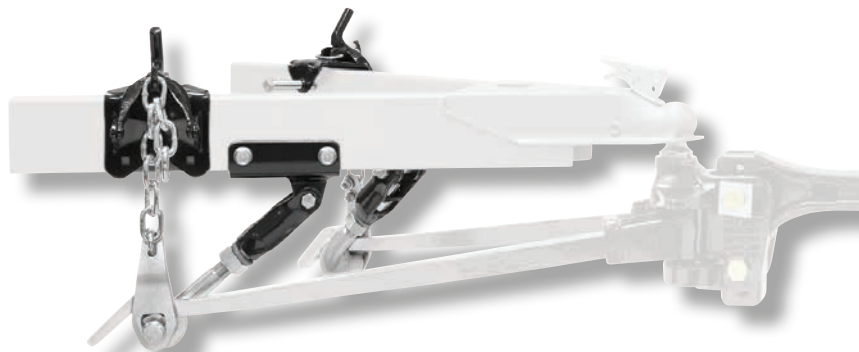



WHY CHOOSE OUR WEIGHT DISTRIBUTING?

We have been the leader in weight distributing systems for more than 60 years. Over those years, much has changed within the industries we serve. Tow vehicles and their frames have been made lighter while the trailers have become heavier. The technology utilized yesterday can no longer be used in today's world.

» QUALITY RAW MATERIALS

- Inspected for adherence to specifications prior to being released to manufacturing



» QUALITY MANUFACTURING PROCESS

- Induction heating prepares the bar stock to be hot-rolled and tapered
- Hot-rolling/tapering (not forging) allows us to control the structure in the steel to give it the desired strength and flexibility
- Austempering heat treat changes the chemical makeup (hardness) of the steel and transforms the raw stock into a spring bar



» QUALITY TESTING

- Spring bars are tested for flexibility and its ability to accept deflection without bending or breaking.
- Rockwell hardness tests are performed to ensure that the raw stock has been transformed into a spring bar.

This is why we've been the leader in weight distributing systems for over 60 years.

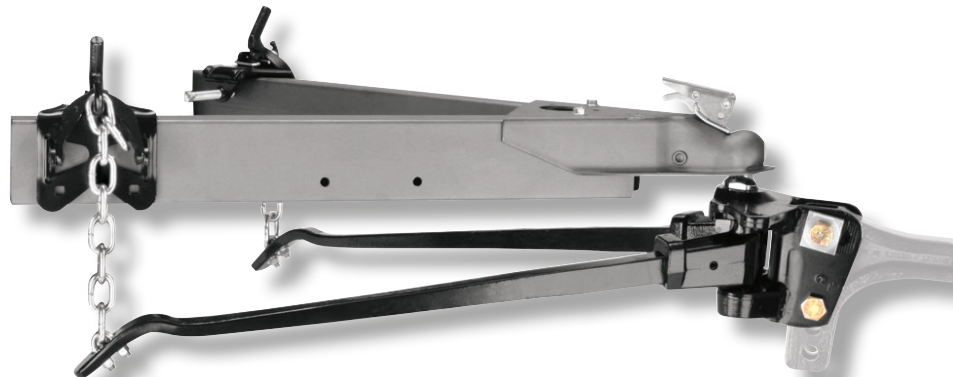

SELECTING THE RIGHT WEIGHT DISTRIBUTION SYSTEM

TO DETERMINE THE CORRECT WEIGHT DISTRIBUTING HITCH:

1. Determine the tongue weight of your trailer
2. Estimate the vehicle cargo load
3. Match the sum of these weights to the proper Reese® weight distributing hitch

HITCH WEIGHT = TONGUE WEIGHT + VEHICLE CARGO LOAD BEHIND REAR AXLE

Tongue weight includes the trailer tongue weight with full gas, water and waste systems and everything packed inside the trailer. Vehicle cargo includes all materials carried in your tow vehicle, such as boat motors, gas cans, tools, etc.

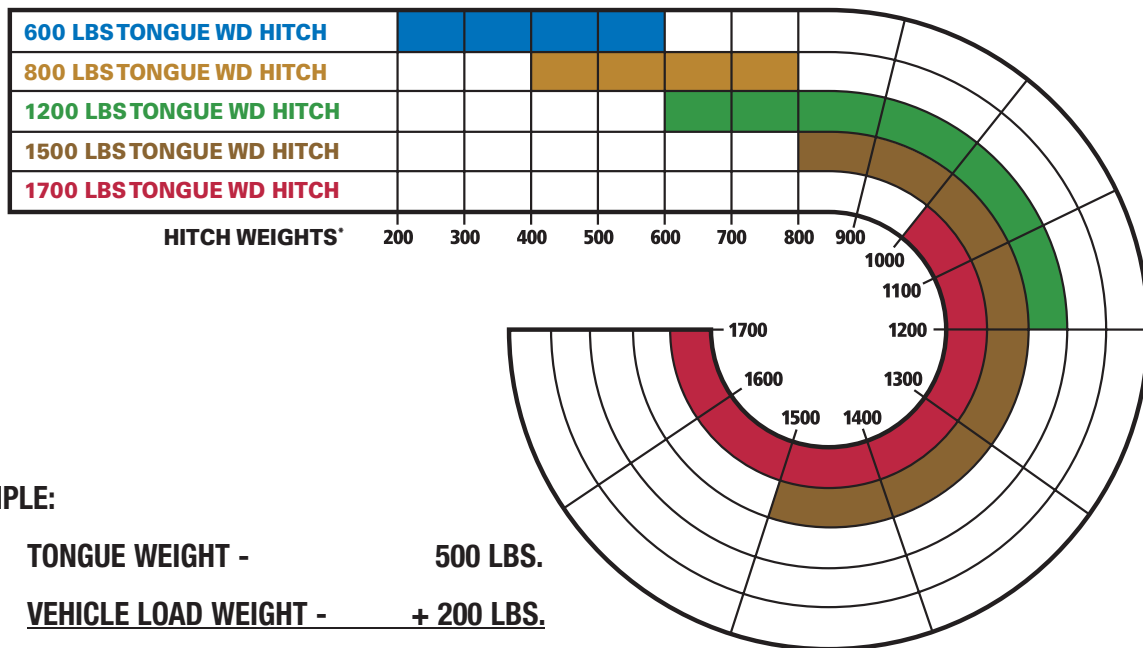

EXAMPLE:

TONGUE WEIGHT - 500 LBS.
VEHICLE LOAD WEIGHT - + 200 LBS.
TOTAL HITCH WEIGHT - = 700 LBS.

Using the selector shown above, an 800 lbs. tongue weight distributing hitch is adequate.

• 600 WEIGHT DISTRIBUTING HITCH

Specially suited for use on medium boat trailers, light travel trailers, single horse trailers, heavy fold-down campers, heavy luggage or utility trailers.

• 800 WEIGHT DISTRIBUTING HITCH

Ideal for medium travel trailers, heavy boat trailers, heavy horse trailers.

• 1200 WEIGHT DISTRIBUTING HITCH

Excellent with heavy travel trailers, extra-heavy boat and horse trailers.

• 1500 & 1700 WEIGHT DISTRIBUTING HITCHES

Great for agricultural, marine and heavy recreational use.



STRAIT-LINE® SYSTEM

This is the ultimate hitch in detail and design. No other hitch gives the driver the control this one does at a reasonable price. The Strait-Line® Hitch consists of our patented Dual Cam High-Performance Sway Control and our High-Performance Weight Distributing System in one easy-to-install package.

The Strait-Line® Hitch was given this name as its pro-active design literally forces the trailer to stay in a straight line behind the tow vehicle. Sway is controlled by the Dual Cam High-Performance System. The stronger the sway force, the more the Dual Cam System works to stop it.

The Strait-Line® Hitch combines weight distributing with the best proven pro-active sway control system available in a newly-designed, easy-to-install kit.

- Simple installation and adjustment
- Fully automatic and self-centering
- Hooking up spring bars automatically hooks up sway control
- Reduced noise
- No U-bolts to interfere with bottle racks or other A-Frame mounted items
- Specific attachment reference points provided
- Easy adjustment of centerline
- No need to relocate items on top of A-Frame to install Dual Cam High-Performance Sway Control
- Limited Lifetime Warranty



STRAIT-LINE® TRUNNION BAR HITCH w/o HITCH BAR

Part No.	Description
66072	Strait-Line® 600 Trunnion Bar (includes 66020 & 26002)
66073	Strait-Line® 800 Trunnion Bar (includes 66021 & 26002)
66074	Strait-Line® 1200 Trunnion Bar (includes 66022 & 26002)
66130	Strait-Line® 1500 Trunnion Bar for Ultra Frame® receivers (includes 66131 & 26002)
66075	Strait-Line® 1700 Trunnion Bar for 2-1/2" receivers (includes 66006 & 26002)



STRAIT-LINE® TRUNNION BAR HITCH w/HITCH BAR #54970

Part No.	Description
66082	Strait-Line® 600 Trunnion Bar w/Hitch Bar (includes 66540 & 26002)
66083	Strait-Line® 800 Trunnion Bar w/Hitch Bar (includes 66541 & 26002)
66084	Strait-Line® 1200 Trunnion Bar w/Hitch Bar (includes 66542 & 26002)



STRAIT-LINE® ROUND BAR HITCH w/HITCH BAR #54970

Part No.	Description
66086	Strait-Line® 600 Round Bar w/Hitch Bar (incl 65509 & 26002)
66087	Strait-Line® 800 Round Bar w/Hitch Bar (incl 67509 & 26002)
66088	Strait-Line® 1200 Round Bar w/Hitch Bar (incl 61009 & 26002)

NOTE: See page E-5 for help selecting the correct Weight Distribution System.



The best integrated friction control system on the market with 6 points of true friction control.



REESE® SC HITCH KITS

- Ratings 600/800/1200/1500 lbs. with hitch bar #54970
- Integrated friction sway control with automotive friction material as used on vehicle brakes – sway control provides consistent control in various weather conditions
- Reese® style serrated washer system allows for easy head adjustment - does not require head removal for washer adjustment
- Raised hitch ball platform
- Clamp on brackets and adjustable pad hangers allow for placement on trailer frames without removing the gas bottles/batteries
- Lift handle accessory included to reduce the amount of lifting required by the trailer jack when preloading the WD system
- Tapered spring bars with preassembled trunnions reduce install time
- Tapered bars provide superior weight distribution performance over a variety of uneven road and weather conditions
- Proven durability
- Limited Lifetime Warranty



Four easy steps to hook up the Spring Bar

Step 1:

Place spring bar and lift handle onto clamp-on bracket



Step 2:

Rotate lift handle upward

Step 3:

Remove lift handle



Step 4:

Close and secure lid with pin

NOTE: See page E-5 for help selecting the correct Weight Distribution System.



REESE® SC W/HITCH BAR #54970

Part No.	Description	Gross Trailer Wt.	Tongue Wt.
66151†	Weight Distributing Hitch	10,000 lbs.	600 lbs.
66153†	Weight Distributing Hitch	10,000 lbs.	800 lbs.
66155†	Weight Distributing Hitch	12,000 lbs.	1,200 lbs.
66157†	Weight Distributing Hitch	15,000 lbs.	1,500 lbs.

REPLACEMENT PARTS

Part No.	Description
58356	600 lbs. Trunnion Spring Bar
58357	800 lbs. Trunnion Spring Bar
58358	1,200 lbs. Trunnion Spring Bar
58359	1,500 lbs. Trunnion Spring Bar
58518	800 lbs. Bracket for Bottom Mounted Couplers
58519	1,200 lbs. Bracket for Bottom Mounted Couplers
58517	Replacement Part, Service Kit, Dual Cam Hanger Brackets

† = Available while supplies last.



STEADi-FLEX®



STEADi-FLEX® LIGHT DUTY WEIGHT DISTRIBUTING KIT

This weight distributing system is designed with tapered spring bars for a softer ride. Friction material, used for sway control, provides a quiet ride. Wide spring bars, with a simple pin and clip assembly, reduce wear in the head and on the friction pads.

- No drill installation
- Will fit 6" frames w/bottom mount couplers
- Hitch bar included
- Hitch ball sold separately
- Limited lifetime warranty



Part No.	Description	Gross Trailer Wt.	Tongue Wt.
66557*	STEADi-FLEX® Light Weight Distributing Kit w/Shank, Built In Friction Sway Control & Hardware	4,000 lbs.	400 lbs.
66558	STEADi-FLEX® Light Weight Distributing Kit w/Shank, Built In Friction Sway Control & Hardware	6,000 lbs.	600 lbs.

* Will not fit on trailer frames that are 2" x 3" or 2" x 3.5"



STEADi-FLEX®



STEADi-FLEX® HEAVY DUTY WEIGHT DISTRIBUTING KIT

This weight distributing system is designed with tapered spring bars for a softer ride. Friction material, used for sway control, provides a quiet ride. Wide spring bars, with a simple pin and clip assembly, reduce wear in the head and on the friction pads.

- No drill installation
- Will fit 6" frames w/bottom mount couplers
- Hitch bar included
- Inegrated sway control
- Limited lifetime warranty



Part No.	Description	Gross Trailer Wt.	Tongue Wt.
66559	STEADi-FLEX® Heavy Duty Weight Distributing Kit w/ Shank, Built In Friction Sway Control & Hardware	10,000 lbs.	1,000 lbs.
66560	STEADi-FLEX® Heavy Duty Weight Distributing Kit w/ Shank, Built In Friction Sway Control & Hardware	12,000 lbs.	1,200 lbs.
66561	STEADi-FLEX® Heavy Duty Weight Distributing Kit w/ Shank, Built In Friction Sway Control & Hardware	14,000 lbs.	1,400 lbs.

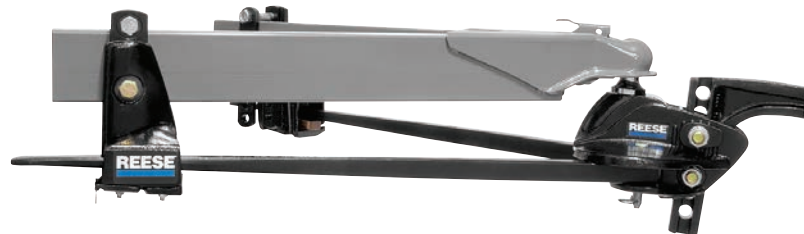



TRUNNION STYLE

Reese® has combined the best of the features from all of our weight distributing kits to create the High-Performance Trunnion Kit. It includes a head design with superior strength and easy adjustment.

The head includes a forged raised ball platform and forged Trunnion mounts. The channel of the head utilizes our “serrated washer” design. The serrated washers make it easier to dial in the set up of the High-Performance Weight Distributing Kit.

In addition to the changes in the head, the High-Performance Weight Distributing Kit includes the highest rated spring bars per class in the industry. They also feature an integrated cam for easy set up with the optional Dual Cam High-Performance Sway Control. Other features include 9-link chains for easier set up on larger trailer frames and innovative snap-up brackets designed for superior strength and durability.

- Raised hitch ball platform eliminates the need for raised hitch balls
- Easy-to-use serrated washers for head adjustment
- Forged ball platform and spring bar mounts
- Rated up to 15,000 lbs. GTW and 1,500 lbs. TW
- Limited Lifetime Warranty



PATENTED INNOVATIVE DESIGN

Easy-to-use serrated washer

Raised hitch ball platform eliminates the need for raised hitch balls

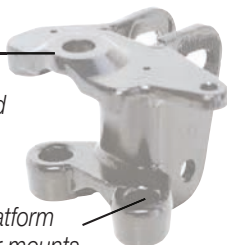

Forged ball platform and spring bar mounts

PATENTED INNOVATIVE DESIGN

Forged integrated cam



NOTE: See page E-5 for help selecting the correct Weight Distribution System.

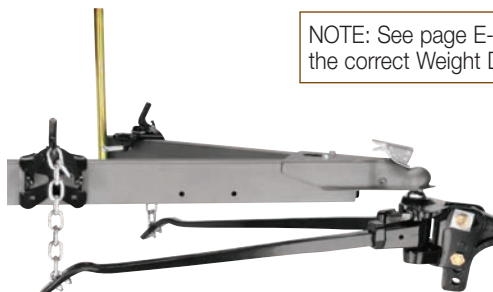

WEIGHT DISTRIBUTION W/O HITCH BAR

Part No.	Description	Gross Trailer Wt.	Tongue Wt.
66020	Weight Distributing Hitch	10,000 lbs.	600 lbs.
66021	Weight Distributing Hitch	10,000 lbs.	800 lbs.
66022	Weight Distributing Hitch	12,000 lbs.	1,200 lbs.
66131*	Weight Distributing Hitch	15,000 lbs.	1,500 lbs.

*U.S. Patent Nos. 5,375,867 and 5,465,991, other patents pending
* Designed to be used with Ultra Frame® receiver*

WEIGHT DISTRIBUTION W/HITCH BAR #54970

Part No.	Description	Gross Trailer Wt.	Tongue Wt.
66540	Weight Distributing Hitch	10,000 lbs.	600 lbs.
66541	Weight Distributing Hitch	10,000 lbs.	800 lbs.
66542	Weight Distributing Hitch	12,000 lbs.	1,200 lbs.

U.S. Patent Nos. 5,375,867 and 5,465,991, other patents pending

REPLACEMENT PARTS

Part No.	Description
58167	Adjustable Ball Mount w/hardware
22225	800 lbs. Trunnion Spring Bar
66009	1,200 lbs. Trunnion Spring Bar
58369	1,500 lbs. Trunnion Spring Bar
6637	Snap Up Bracket Assembly Kit w/handle (2-piece)
21501	Snap Up Bracket w/Set Screw & Safety Pin
58392	Snap Up Bracket w/Set Screw & Safety Pin (for use w/Weight Distribution Systems w/ Tongue Weights 800 lbs. and Over)
58207	Ball Mount Shim Kit



58167



ROUND BAR STYLE

The Round Bar Weight Distributing Hitch features easy-to-use adjusting blocks for easier and faster ball mount angle adjustment. It includes a one-piece cast head, snap-up brackets and chains; spring bars include an integrated cam for use with optional dual cam sway control.



In addition to the changes in the head, the Round Bar Weight Distributing Kit includes the highest rated spring bars per class in the industry. They also feature an integrated cam for easy set up with the optional Dual Cam High-Performance Sway Control. Other features include 9-link chains for easier set up on larger trailer frames and innovative snap-up brackets designed for superior strength and durability.

- Easy-to-use adjusting washers for head adjustment
- One piece cast head
- Rated up to 12,000 lbs. GTW and 1,200 lbs. TW
- Limited Lifetime Warranty



PATENTED INNOVATIVE DESIGN

Easy-to-use adjusting washer

One piece cast head

Integrated right hand sway control platform



PATENTED INNOVATIVE DESIGN

Forged integrated cam



NOTE: See page E-5 for help selecting the correct Weight Distribution System.

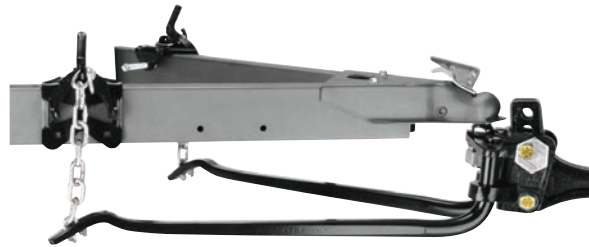

WEIGHT DISTRIBUTION w/HITCH BAR #54970

Part No.	Description	Gross Trailer Wt.	Tongue Wt.
65509	Weight Distributing Hitch	10,000 lbs.	600 lbs.
67509	Weight Distributing Hitch	10,000 lbs.	800 lbs.
61009	Weight Distributing Hitch	12,000 lbs.	1,200 lbs.

REPLACEMENT PARTS

Part No.	Description
58112	Adjustable Ball Mount w/hardware
58114	800 lbs. Round Spring Bar
58115	1,200 lbs. Round Spring Bar
6637	Snap Up Bracket Assembly Kit w/handle (2-piece)
21501	Snap Up Bracket w/Set Screw & Safety Pin
58392	Snap Up Bracket w/Set Screw & Safety Pin (for use w/Weight Distribution Systems w/ Tongue Weights 800 lbs. and Over)
58207	Ball Mount Shim Kit



58112



58114

58115



6637



REESE® WEIGHT DISTRIBUTING TRUNNION STYLE

Designed for loads beyond normal everyday towing situations, Reese® Weight Distributing Hitch systems provide a trunnion design with the highest rating available in the towing industry. Coupled with a 2-1/2" Class V receiver, heavy loads are transported with ease. Ideal for commercial and industrial use.



- Trunnion style weight distributing kit with integrated cams for use with Dual Cam Sway Control
- Perfect for use with horse trailers and RV's with heavy tongue weights
- Adjustable hitch bar sold separately
- Great for agricultural, marine and recreational use
- Limited Lifetime Warranty

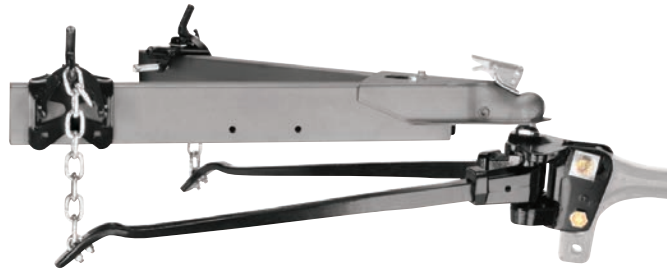

54977†

REESE® WEIGHT DISTRIBUTING TRUNNION STYLE W/O HITCH BAR

Part No.	Description	Gross Trailer Wt.	Tongue Wt.
66006	Weight Distributing Hitch	17,000 lbs.	1,700 lbs.

Note: Do not exceed tow vehicle, hitch or equipment ratings.

REESE® HITCH BAR SELECTION CHART

Part No.	Total Ht Adj	Length (L)	Rise (R)	Drop (D)	GTW/TW (lbs.)
54977†	14-1/4"	11-1/2"	8-1/4"	5-3/4"	17,000/1,700

NOTE: Do not exceed tow vehicle, hitch or equipment rating



58167

REPLACEMENT PARTS

Part No.	Description
58167	Reese® Trunnion Bolt-Together Head Kit w/ hardware
58392	Snap Up Bracket w/Set Screw & Safety Pin (for use w/Weight Distribution Systems w/ Tongue Weights 800 lbs. and Over)

NOTE: See page E-5 for help selecting the correct Weight Distribution System.

† = Available while supplies last.

COMPLETE ROUND BAR KIT

The innovative Complete Round Bar weight distribution is engineered to provide the features you expect in a weight distribution kit at an economical price.



- Provides everything needed to improve towing, safety and performance right out of the box
- Preinstalled and torqued sway control ball and 2-5/16" hitch ball, u-bolts and chains
- Fabricated head and welded hitch bar
- Includes friction sway control and mounting hardware
- Limited lifetime warranty



Part No.	Description	Gross Trailer Wt.	Tongue Wt.
49901	Complete Round Bar WD Kit	10,000 lbs.	550 lbs.
49902	Complete Round Bar WD Kit	10,000 lbs.	750 lbs.
49903	Complete Round Bar WD Kit	10,000 lbs.	1,000 lbs.
49904	Complete Round Bar WD Kit	10,000 lbs.	1,200 lbs.

REPLACEMENT PARTS

Part No.	Description
58439	Complete RB, 550 lbs. Spring Bar w/o Bend (Qty. 2)
58440	Complete RB, 750 lbs. Spring Bar w/o Bend (Qty. 2)
58441	Complete RB, 1000 lbs. Spring Bar w/o Bend (Qty. 2)
58442	Complete RB, Weight Distributing Bolt-Together Head w/2-5/16" Chrome Hitch Ball, Sway Control Ball & Mounting Hardware
58444	Complete RB, Weight Distributing Bolt-Together Head Shim Kit

Note: Minimum purchase requirements for these products. Please contact your Horizon Global sales representative for further details.

TRUNNION STYLE

The innovative Trunnion weight distribution is engineered to provide the features you expect in a weight distribution kit at an economical price.



- New combination single piece cast head
- Easy to use adjusting washers
- Unique washer design allows for quick spring bar tension adjustment
- Round tapered spring bars
- Head is compatible with optional Friction Sway Control (each side)
- Includes hitch bar #63970
- Limited lifetime warranty



WEIGHT DISTRIBUTION W/HITCH BAR #63970

Part No.	Description	Gross Trailer Wt.	Tongue Wt.
49585†	Weight Distributing Hitch	10,000 lbs.	600 lbs.
49586†	Weight Distributing Hitch	10,000 lbs.	800 lbs.
49587†	Weight Distributing Hitch	12,000 lbs.	1,200 lbs.

Available in skid quantities of 20. (Example: 49585-020)

† = Available while supplies last.

NOTE: See page E-5 for help selecting the correct Weight Distribution System.

COMPLETE RB2 ROUND BAR

The innovative RB2 Round Bar weight distribution is engineered to provide the features you expect in a weight distribution kit at an economical price.



- New combination single piece cast head
- Easy to use adjusting washers
- Unique washer design allows for quick spring bar tension adjustment
- Head is compatible with optional Friction Sway Controls (each side)
- Includes hitch bar #63970
- Limited lifetime warranty



WEIGHT DISTRIBUTION W/HITCH BAR #63970

Part No.	Description	Gross Trailer Wt.	Tongue Wt.
49568	Weight Distributing Hitch	10,000 lbs.	600 lbs.
49569	Weight Distributing Hitch	10,000 lbs.	800 lbs.
49570	Weight Distributing Hitch	12,000 lbs.	1,200 lbs.

Available in skid quantities of 20. (Example: 49570-020)

COMPLETE ROUND BAR RB3

- Fabricated head and welded hitch bar
- Available in 550/750/1,000 lbs kits
- Head is compatible with optional Friction Sway controls (each side)
- Limited lifetime warranty

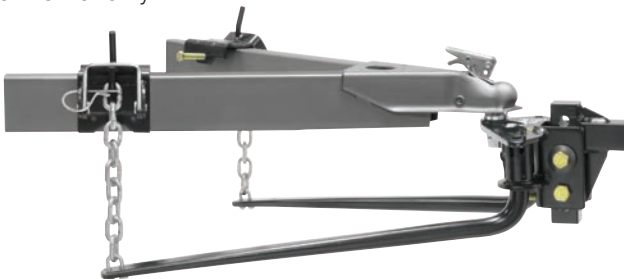

WEIGHT DISTRIBUTION W/HITCH BAR #63970

Part No.	Description	Gross Trailer Wt.	Tongue Wt.
49581	Weight Distributing Hitch	10,000 lbs.	550 lbs.
49582	Weight Distributing Hitch	10,000 lbs.	750 lbs.
49583	Weight Distributing Hitch	10,000 lbs.	1,000 lbs.

REPLACEMENT PARTS

Part No.	Description
58439	Complete RB, 550 lbs. Spring Bar w/o Bend (Qty. 2)
58440	Complete RB, 750 lbs. Spring Bar w/o Bend (Qty. 2)
58441	Complete RB, 1000 lbs. Spring Bar w/o Bend (Qty. 2)
58442	Complete RB, Weight Distributing Bolt-Together Head w/2-5/16" Chrome Hitch Ball, Sway Control Ball & Mounting Hardware
58444	Complete RB, Weight Distributing Bolt-Together Head Shim Kit

Available in skid quantities of 20. (Example: 49583-020)

NOTE: See page E-5 for help selecting the correct Weight Distribution System.

Dual Cam HP



DUAL CAM HIGH-PERFORMANCE SWAY CONTROL

This patented product is Reese® Products main technique for controlling trailer sway. Unlike Friction Sway Control, this approach works to control sway from the start rather than just resisting sway once it's begun. And it works only when needed. The advantage of the Dual Cam System is its ability to forestall sway in addition to sway resistance. It works to hold down the start of swaying activity while at the same time allowing free and easy vehicle and trailer interaction. Another advantage of the Dual Cam System is that it is installed on the trailer and therefore does not require adjustment every time the towing vehicle and trailer are hooked up, unless hitch weight or tow vehicle loading are changed.

- Integrated cams into the spring bars reduce noise
- No U-bolts to interfere with bottle racks or other A-Frame mounted items
- Specific attachment reference points provided
- Fits most applications
- Improved installation times
- Years of extensive field testing
- Limited lifetime warranty



Part No.	Description
26002	Dual Cam High Performance Sway Control
58507	Rivet Nuts (Qty. 4) for tube frames (Dual Cam High Performance Bracket)

Weight distributing hitch not included; use of sway controls with surge brakes not recommended; this product is recommended to be used with weight distribution that has the integrated spring bars only

FRICTION SWAY CONTROL

- Installs and removes easily
- Removes with two spring locking pins
- Heavy construction for added reliability
- Friction brake keeps trailer and tow vehicle stable
- Quick attachment to trailer frame and ball mount
- Can be used on left and right side of trailer



Part No.	Description
83660	Sway Control Assembly and fasteners - (boxed)
26660†	Sway Control Assembly and fasteners - (boxed)
3442	Weld-on Sway Control adapter
58060	Replacement Sway Control ball 1-1/4" x 5/8"
58062	Replacement Ball Plate Assembly

Weight distributing hitch not included; use of sway controls with surge brakes is not recommended

BOLT-ON MOUNTING ADAPTERS FOR SWAY CONTROL

- Easy bolt-on installation
- Bulk packaged
- Black powder coat finish over A-coat



Part No.	Description
26003	Sway Control Adapter Bracket for Class III & IV 2" ball mounts
26005	Sway Control Adapter Bracket for Class II 1-1/4" drawbars

26003 cannot be used with Class I or Class II Drawbars.
26005 cannot be used with Class I Drawbars.

Ball platform does not prevent adapter from turning during tightening.

ADJUSTABLE BALL MOUNTS W/ HITCH BARS



Part No.	Description
54980	Complete Adjustable Ball Mount with 54970 Hitch Bar
54994	Complete Adjustable Ball Mount with 54998 Hitch Bar

HITCH BARS



WEIGHT DISTRIBUTING HITCH BARS

Sold separately from the Weight Distributing Hitch Kits, hitch bars offer a full range of style and adjustability. Designed for use with all Trunnion and Round Bar Weight Distributing Kits.

- Angled, extended, "T" and deep drop designs available
- Designed for use in the rise or drop position
- Refer to the diagrams below to assist in determining the correct Length, Rise & Drop required when selecting the correct hitch bar for your Weight Distributing Hitch.

A: HEIGHT
B: LENGTH
C: RISE
D: DROP

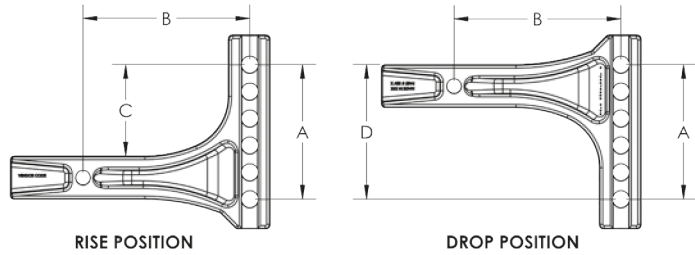

How to measure for the proper hitch bar
 (Illustrations show Adjustable Hitch Bar)



Part No	Hitch Bar Size	Capacity lbs. (TW)	A Height (in.)	B Length (in.)	C-D Rise - Drop (in.)	Cast / Welded
3214	2"	1,400	6-1/4"	11-3/4"	4-1/4" - 6-1/4"	Welded
3215	2"	1,400	6-1/4"	8-3/4"	8-3/4" - 10-3/4"	Welded
3344	2"	1,400	5"	8-3/4"	N/A - 13-1/4"	Welded
54970	2"	1,500 (1,000)	6-1/4"	9-1/4" (10-1/4")	4-1/4" - 6-1/4"	Cast
63971	2"	1,500	7-1/2"	9-3/4"	N/A - 10"	Cast
54998	2"	1,600	7-1/2"	9-1/4"	4-7/8" - 6-7/8"	Cast
63911	2"	1,200	6-1/4"	7-3/4"	4-1/4" - 6-1/4"	Cast
54976	2-1/2"	1,700	6-1/4"	11-1/2"	1-1/4" - 5-1/4"	Cast

NOTE: Do not exceed tow vehicle, hitch or equipment rating



LOAD-MASTER TRAILER TONGUE WEIGHT SCALE

- Load-Master is a hydraulic pressure gauge for measuring trailer tongue weights from 0 to 2,000 lbs.

Part No.	Description
5780	Load-Master Trailer Tongue Weight Scale

POLE TONGUE ADAPTER

A Pole Tongue Adapter is used as a mounting platform for the Lift Brackets of a Weight Distributing Hitch System when a trailer has a pole or straight tongue rather than an A-Frame tongue.

- Fits all lift units regardless of manufacturer
- Fits tongue widths from 1-5/8" to 5"
- Fits tongue heights from 3" to 6"

Part No.	Description	Gross Trailer Wt.	Tongue Wt.
3280	Pole Tongue Adapter and Fastener Kit	7,500 lbs.	750 lbs.
58393	Pole Tongue Adapter and Fastener Kit	14,000 lbs.* 12,000 lbs.**	1400 lbs.* 1200 lbs.**

Note: Not for use with light duty weight distributing hitch
** When mounted on top of the tongue*
*** When mounted below the tongue*

WEIGHT DISTRIBUTING CHAIN HANGERS

For trailers with tongue interference (gas bottles, batteries, covered frames, etc.) where snap up brackets (#21501) won't install easily, we offer two easy-to-install options.



- Black powder coat finish over A-coat
- Installs quickly! (approximately 15 minutes)
- Includes hardware

Part No.	Description	Gross Trailer Wt.	Tongue Wt.
58305	Chain Hanger, Bolt On	14,000 lbs.	1400 lbs.
58306	Chain Hanger, Clamp On	14,000 lbs.	1400 lbs.

WEIGHT DISTRIBUTING SNAP UP BRACKETS

- Rugged positive locking design
- Unit locks using safety pin (#55180)
- Narrower, for increased frame clearance
- One-piece cast chain hook
- Black powder coat finish over A-coat



Part No.	Description
6637	Snap Up Bracket Assembly Kit w/handle (2- piece)
58162	Snap Up Handle
21501	Snap Up Bracket w/Set Screw & Safety Pin
58392	Snap Up Bracket w/Set Screw & Safety Pin (for use w/Weight Distribution Systems w/ Tongue Weights 800 lbs. and Over)

REESE® REVOLUTIONIZING THE 5TH WHEEL



FIFTH WHEEL HITCHES

REESE® ELITE™ FIFTH WHEEL HITCHES

Reese® Elite™ 26.5K.	3	20K Fifth Wheel with Square Tube Slider.	13
Reese® Elite™ 25K.	3	16K Fifth Wheel.	14
Reese® Elite™ 18K.	3	16K Fifth Wheel with Square Tube Slider.	14
Reese® Elite™ Rail Kits.	4	16K Fifth Wheel.	15
Reese® Elite™ Rail Kit Application Guide.	4	16K Fifth Wheel with Square Tube Slider.	15
Reese® Elite™ Above-Bed Gooseneck.	5	Fifth Wheel Hitch Service Kits.	15
Reese® Elite™ 20K Drop-In For Ram 2500/3500 HD.	5		
Reese® Elite™ Rail Kit Mounting Adapters.	6		

FIFTH WHEEL ACCESSORIES

Lube Plates.	18
Locks & Chain Kits.	18
Capture Plates.	18
Rails & Installation Kits.	19

REESE® FIFTH WHEEL HITCHES

Reese® 20K.	7
Reese® 16K.	7
Reese® Round Tube Sliders.	8
Reese® Outboard Mounting Rails.	8
Reese® Outboard Installation Brackets & Kits.	8-9

FIFTH WHEEL HITCH DIMENSIONS

Fifth Wheel Height Dimensions.	16
Mounting Rail Height Dimensions.	16
Mounting Adapter Height Dimensions.	16

REESE® SELECT SERIES FIFTH WHEELS

Reese® Select 20K.	10
Reese® Select Low Profile 30K.	11
Reese® Select 22K.	11
Reese® Select 16K.	12

FIFTH WHEEL HITCH APPLICATION GUIDES

Elite™ Fifth Wheel Rail Kits.	4
Custom Quick Install Bracket & Complete Outboard Kit.	9
Fifth Wheel 10 Bolt Rail Kits.	20
Fifth Wheel Universal Rail Kits.	21

FIFTH WHEEL HITCHES

25K Fifth Wheel.	12
20K Fifth Wheel.	13

NEW PRODUCTS



OUTBOARD FIFTH WHEEL BRACKETS

- Vehicle specific outboard fifth wheel custom quick install brackets



CUSTOM QUICK INSTALL BRACKETS

- Vehicle specific fifth wheel custom quick install brackets
- Kits also available that include mounting rails

FEATURED PRODUCTS



REESE® ELITE™ ABOVE-BED GOOSENECK

- Specifically designed for the Professional tower who employs both fifth wheel and gooseneck trailers



REESE® SELECT SERIES FIFTH WHEELS

- Two-jaw locking system
- Side-to-side pivot action



REESE® ELITE™ FIFTH WHEELS

- Increased king pin/jaw contact design, king pin indicator and self latch system



REESE® RAM DROP-IN FIFTH WHEEL

- Direct fit for RAM trucks with OE tow package



ELITE™



30871

Includes 90° Wire Harness 50-97-410



PRE ASSEMBLED 26.5K ELITE™

- 26,500 lbs. capacity / 6,625 lbs. pin weigh capacity
- Improved 4 way head pivot
- 4° side to side pivot for better control
- Forged single jaw
- Increased king pin/jaw contact design
- Self latching jaw design
- King pin indicator
- Wider footprint for increased stability
- Stamped rounded head
- Wider 9" (vs 6") king pin funnel area on head
- Vehicle specific under bed mounting kits
- Lockable handle (Pad lock sold separately)
- 1/4" turn handle "quick lock" mount system
- Non-pin mounting reduces slop
- Contemporary 21st century appearance
- Extended length handle
- Pre-assembled fifth wheel units
- Saves approximately one hour of assembly time
- Foot assembly is hand tightened
- Includes wrench to tighten foot assembly
- Shipped in one convenient carton
- SAE J2638 Compliant
- Limited Lifetime Warranty



Part No.	Description	Vertical Adjustment
30871	26.5K Elite™ - pre assembled	15" to 17-1/2"

Note: Will not fit trucks with beds shorter than 6' in length unless used with Sidewinder™. Will not fit trucks with flareside/stepside.

REPLACEMENT PARTS

Part No.	Description
58541	26.5K Elite Series Fifth Wheel Center Section
58542	26.5K Elite Series Fifth Wheel Center Section Bolt Kit
58543	26.5K Elite Series Fifth Wheel Base Arches



30143†

Includes 90° Wire Harness 50-97-410



PRE ASSEMBLED 25K ELITE™

All 26.5K features other than gross and pin weight capacity.

- 25,000 lbs. capacity / 6,250 lbs. pin weight capacity
 - SAE J2638 Compliant

Part No.	Description	Vertical Adjustment
30143†	25K Elite™ - pre assembled	14-1/2" – 17"

Note: Will not fit trucks with beds shorter than 6' in length unless used with Sidewinder™. Will not fit trucks with flareside/stepside.



30142

Includes 90° Wire Harness 50-97-410



PRE ASSEMBLED 18K ELITE™

All 25K features other than gross and pin weight capacity.

- 18,000 lbs. capacity / 4,500 lbs. pin weight capacity
- SAE J2638 Compliant

Part No.	Description	Vertical Adjustment
30142	18K Elite™ - pre assembled	14-1/2" – 18-1/4"
30144	18K Elite™ with Slider - pre assembled	16-1/2" – 19"

Note: Will not fit trucks with beds shorter than 6' in length unless used with Sidewinder™. Will not fit trucks with flareside/stepside.



30144

† = Available while supplies last.



ELITE™ RAIL KITS



Elite™ Rail Kits are designed for use with the Elite™ Systems only.

- “Power Puck” mounting system provides uninhibited use of truck bed when fifth wheel or gooseneck is dismantled
- Wider platform/mounting footprint (increased stability)
- Custom-fit under-bed mounting system
- Black powder coat finish
- SAE J2638 Compliant

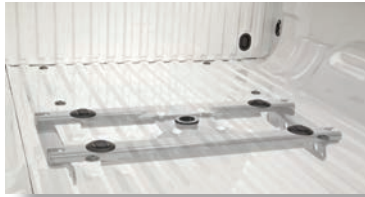

30868
GM Applications



30852
Dodge Applications



30126
Ford Applications

REESE® ELITE™ FIFTH WHEEL RAIL KITS APPLICATION GUIDE

Make/Model	Style	Years	Bracket#	NoDrill	FN
Chevrolet/GMC					
Silverado/Sierra 1500	Except 8 ft. Bed(Classic)	99-07	30061	Ø	SW
Silverado/Sierra 1500 HD	(Classic)	01-07	30061	Ø	
Silverado/Sierra 2500	Except 8 ft. Bed	99-04	30061	Ø	
Silverado/Sierra 2500 HD	Except 8 ft. Bed	01-10	30061		
Silverado/Sierra 2500 HD		11-16	30868	Ø	
Silverado/Sierra 3500 HD	Except 8 ft. Bed	07-10	30061		
Silverado/Sierra 3500 HD		11-16	30868	Ø	
Dodge/Ram					
Ram 1500	Except Mega Cab	02-08	30067		
Ram 1500		02-08	30074	Ø	
Ram 2500	Except Mega Cab	03-12	30067		
Ram 2500		03-13	30074		
Ram 2500		10-12	30852		
Ram 3500	Except Mega Cab	03-12	30067		
Ram 3500		03-12	30074		
Ram 3500		10-12	30852		
Ford					
F-150		04-14	30064		SW
F-250/350 Super Duty	Except Cab & Chassis	99-10	30073		
F-250/350 Super Duty	Except Cab & Chassis	11-16	30126	Ø	
F-450 Super Duty	Except Cab & Chassis	08-10	30073		
F-450 Super Duty	Except Cab & Chassis	11-16	30126	Ø	

SW - Do not install on a truck with less than a 6' long bed unless the trailer is equipped with a Sidewinder pin box coupler #SW16K or #SW19K.



30061
GM Applications



30067
Dodge Applications



30074
Dodge Applications



30073
Ford Applications



ELITE™



30845

For use with Elite™ rail kits only



30149



58419



30863



30864



117300

ELITE™ SERIES ABOVE-BED GOOSENECK

- Rated for 25,000 lbs. capacity
- 2-5/16" high strength zinc plated ball
- Specifically designed for the Professional tower who employs both fifth wheel and gooseneck trailers
- Utilizes the same vehicle specific under-bed rail kit system as the Elite™ fifth wheel
- Above-Bed Gooseneck can be easily removed for unobstructed use of the truck bed
- Weather resistant plastic covering provides protection from the elements and aesthetic appeal
- Built-in chain bracket to accommodate safety chain
- Limited Lifetime Warranty



Part No.	Description
30845	25K Elite™ Series Gooseneck

Note: Will not fit trucks with beds shorter than 6' in length. Will not fit trucks with flareside/stepsides.

ACCESSORY/REPLACEMENT PARTS

Part No.	Description
30149	Elite™ Rail Kit Accessory, Plastic Bedliner Puck Adapter Kit (includes: (4) Pucks & (4) Spacers)
58419	Service kit adapter for Signature Series Fifth Wheels & Goosenecks when used on Elite™ Rail Kits (#30126 & #30868) & Ford OEM rail kits
58458	Replacement Part, Trim Rings (4) for GM and Dodge Elite™ Rail Kits

REESE® 20K FIFTH WHEEL, DROP-IN FOR RAM 2500 HD/3500 HD

- 20,000 lbs. capacity / 5,000 lbs. pin weight capacity
- 14-1/4" – 18" vertical adjustment
- Direct fit for RAM trucks with OE tow package
- Built-in handles for easy, safe installation and removal
- Built with Elite™ series fifth wheel head
- SAE J2638 Compliant
- Limited Lifetime Warranty



Part No.	Description
30160	Reese® 20K Fifth Wheel, Drop-In for RAM 2500 HD/3500 HD w/Factory Installed OE Rail System

REPLACEMENT PARTS

Part No.	Description
30863	Center Section, Drop-In for Ram Drop In #30160
30864	Fifth Wheel Base Arches, Drop-In for Ram #30160
117300	Elite™ Fifth Wheel Head Kit

RAIL KIT MOUNTING ADAPTER



30156

- 20,000 lbs. gross / 5,000 lbs. pin weight capacity
- SAE J2638 Compliant
- The robust Reese adapter will not touch or scratch the truck bed
- Works with any 15K, 16K, or 20K standard fifth wheel hitch
- Uses the fast and secure Reese® patented latching system
- Built-in handles for safe, easy installation and removal
- Limited Lifetime Warranty

Part No.	Description
30156	Rail Kit Mounting Adapter, for Ford OEM and Elite™ Series Under-Bed Rail Kits



30154

- 25,000 lbs. gross / 6,250 lbs. pin weight capacity
- SAE J2638 Compliant
- Use with RAM OEM under-bed rail kit
- The robust Reese adapter will not touch or scratch the truck bed
- Works with any standard fifth wheel hitch up to 25k
- Uses the fast and secure Reese® patented latching system
- Limited Lifetime Warranty

Part No.	Description
30154	Rail Kit Mounting Adapter, Drop-In for RAM 2500 HD/3500 HD w/Factory Installed OE Rail System



REESE® 16K FIFTH WHEEL

Reese®, the brand that started the towing industry once again revolutionizes the fifth wheel hitch with the introduction of the Titan® 16K. Reese® remains unmatched in safety, reliability and performance.



30866†



CONTOURED HANDLE



CAST HEAD & JAW



CAST PIVOT BEAM



30869†



30870†

- 16,000 lbs. capacity / 4,000 lbs. pin weight capacity
- CONTOURED HANDLE
 - Customized grip includes universal control instructions
 - New control handle eliminates separate latch and high visibility for system lock and load
- PREMIUM REESE ARCH
 - Updated pin mounting holes better align with current rail kits, reducing looseness
- SAE J2638 COMPLIANT
 - Based on heavy duty, accelerated life cycle criteria developed by SAE for fifth wheels
 - Fatigue and static tested to pass 900,000 cycles
- SIDEWINDER COMPATIBLE
 - Premium choice for short bed trucks
- CAST HEAD
 - Commercial durability and strength
 - Improved head funneling for king pin to latch
 - Patent pending king pin indicator is highly visible
- CAST JAW SYSTEM
 - Double jaw mechanism, heavier for longer wear, improved tolerances, eliminating chucking in jaw system
 - Improved life and wear with added grease points
- CAST PIVOT BEAM
 - Incorporates a dual vibration isolator system for vertical and longitudinal vibration dampening and improved ride
 - Wider mounting for better stability and reduced wear
 - Easier assembly of cast pivot beam to cross member
 - Head and pivot beam can be offset 1" front or rear to maximize performance
- Requires rails & installation kit (sold separately)
- Optional slider available for additional turning clearance
- Limited Lifetime Warranty



Part No.	Description	Vertical Adjustment
30866†	16K Fifth Wheel Hitch	13-3/4" to 17-3/4"
30869†	16K Fifth Wheel Hitch and Round Tube Slider	16-1/4" to 19"
83003†	16K Fifth Wheel Lube Plate	—
83004†	16K Fifth Wheel 12" Thin Round Lube Plate, 1/8" Thick	—

Note: Will not fit trucks with beds shorter than 6' in length unless used with Sidewinder™. Will not fit trucks with flareside/stepside.

REESE® 20K FIFTH WHEEL

- 20,000 lbs. capacity / 5,000 lbs. pin weight capacity
- All Titan® 16K features PLUS quadruple vibration isolator system for vertical and longitudinal vibration dampening and improved ride
- Custom lube plate included
- Limited Lifetime Warranty

Part No.	Description	Vertical Adjustment
30867†	20K Fifth Wheel Hitch	14-1/4" – 18-1/4"
30870†	20K Fifth Wheel Hitch and Round Tube Slider	16-3/4" – 19-1/2"

Note: Will not fit trucks with beds shorter than 6' in length unless used with Sidewinder™. Will not fit trucks with flareside/stepside.

† = Available while supplies last.

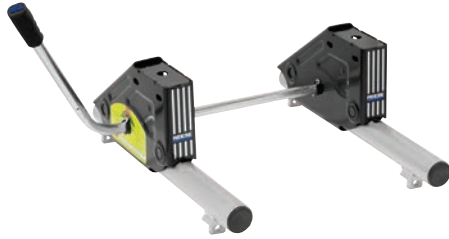

50024

REESE® ROUND TUBE SLIDER

- Up to 20,000 lbs
- 10" travel fore-and-aft
- Slider system re-engineered to be the best in the industry
- Current slider systems expanded to give true ease and precision
- Contoured rollers float from side to side to accommodate mounting systems that may not be fully square
- Embossed roller supports for low friction and longer wear
- Forged mounting feet for wide consistent attachment to rails
- Updated pin mounting holes to better align with the current rail kits and reduce play
- Plated rails hold up longer for extended wear
- SAE J2638 COMPLIANT
 - Based on heavy duty, accelerated life cycle criteria developed by SAE for fifth wheel and gooseneck
 - SAE J2638 is a fatigue and static requirements of new European style test of 900,000 cycles
 - New customized grip
- Limited lifetime warranty



Part No.	Description
50024	Round Tube Slider



58493

REPLACEMENT PARTS

Part No.	Description
58493	Titan® Round Tube Slider Handle, Grip, Roll Pin & Cotter Pins



30153

REESE® OUTBOARD MOUNTING RAILS

- SAE J2638 COMPLIANT
 - Based on heavy duty, accelerated life cycle criteria developed by SAE for fifth wheels
 - J2638 are fatigue and static requirements based on the European style test of 900,000 cycles
- HARDWARE
 - Grade 8 hardware, meets all Canadian requirements
- FAST CUSTOM MOUNT SYSTEM
 - Rails are wider (48") for faster install, because the mounting points are outside the truck frame, allowing the installer to avoid under-bed components
- Limited lifetime warranty



58467

Part No.	Description
30153	Reese® Outboard Fifth Wheel Mounting Rails Only (10 bolt design)

ACCESSORY PARTS

58467	4 Hole Style Pins (Qty. 4) & Clips (Qty. 4) for Reese Outboard Fifth Wheel Mounting Rails #30153
-------	--



Vehicle Specific Brackets - Kits with Vehicle Specific Brackets and Mounting Rails

REESE® OUTBOARD INSTALLATION BRACKETS AND KITS

- Vehicle specific Reese Outboard Fifth Wheel Custom Quick Install Brackets available
- Kits also available that include Reese Outboard Fifth Wheel Mounting Rails and Vehicle Specific Brackets

FIFTH WHEEL CUSTOM QUICK INSTALL BRACKET & COMPLETE OUTBOARD KIT APPLICATION GUIDE



Make/Model	Style	Years	Brkt#	Rail#	ComboKit	NoDrill	FN
Chevrolet/GMC							
Silverado/Sierra 1500	(Classic)	99-07	56007	30153	56007-53	Ø	SW
Silverado/Sierra 1500	Does Not Fit MagneRide Magnetic Ride Suspension	07-17	56007	30153	56007-53	Ø	SW
Silverado/Sierra 1500 HD	(Classic)	01-07	56007	30153	56007-53	Ø	
Silverado/Sierra 2500		99-04	56007	30153	56007-53	Ø	
Silverado/Sierra 2500	(Classic)	01-07	56007	30153	56007-53	Ø	
Silverado/Sierra 2500 HD		07-10	56007	30153	56007-53	Ø	
Silverado/Sierra 2500 HD		08-10	56004†	30153	56004-53†	Ø	
Silverado/Sierra 2500 HD	6.6 ft. Bed	08-10	56014†	30153	56014-53†	Ø	
Silverado/Sierra 2500 HD		11-16	56001	30153	56001-53	Ø	
Silverado/Sierra 3500	(Classic)	01-07	56007	30153	56007-53	Ø	
Silverado/Sierra 3500 HD		07-10	56007	30153	56007-53	Ø	
Silverado/Sierra 3500 HD		08-10	56004†	30153	56004-53†	Ø	
Silverado/Sierra 3500 HD	6.6 ft. Bed	08-10	56014†	30153	56014-53†	Ø	
Silverado/Sierra 3500 HD		11-16	56001	30153	56001-53	Ø	
Dodge/Ram							
Ram 2500		03-13	56011	30153	56011-53	Ø	
Ram 2500		14-17	56009	30153	56009-53	Ø	
Ram 3500		03-12	56011	30153	56011-53	Ø	
Ram 3500	Except w/RamBox Cargo Management System or Models w/Air	13-16	56010	30153	56010-53	Ø	
Ford							
F-150		04-14	56006	30153	56006-53	Ø	SW
F-150		15-16	56034	30153	56034-53	Ø	SW
F-250/350 Super Duty	Except Cab & Chassis	99-10	56005	30153	56005-53	Ø	
F-250/350 Super Duty	Except Cab & Chassis	11-16	56016	30153	56016-53	Ø	
F-250/350 Super Duty	Except Cab & Chassis	17	56017	30153	56017-53	Ø	
F-450 Super Duty	Except Cab & Chassis	08-10	56005	30153	56005-53	Ø	
F-450 Super Duty	Except Cab & Chassis	11-16	56016	30153	56016-53	Ø	
F-450 Super Duty	Except Cab & Chassis	17	56017	30153	56017-53	Ø	

SW - Do not install on a truck with less than a 6' long bed unless the trailer is equipped with a Sidewinder pin box coupler #SW16K or #SW19K.

† = Available while supplies last.

THE FIFTH WHEEL YOU KNOW, BUT BETTER!



Reese® 20K fifth wheel



30081

Reese® 20K fifth wheel
offered with round tube slider



30083

Reese® 20K fifth wheel
offered with square tube slider



30084



**TOWING HAS NEVER BEEN EASIER WHEN USING
THE REESE® 20K FIFTH WHEEL SYSTEM.**

Features our Elite™ head, with the base and mounting kit that you already know & love from our Reese® line of fifth wheel hitches!

The above bed rail system uses the popular universal mounting kit 30035 (sold separately) or the vehicle specific custom quick install kits which reduce install time by up to fifty percent.

REESE® 20K FIFTH WHEEL

- 20,000 lbs. capacity / 5,000 lbs. pin weight capacity
- Features Elite™ Series head...
 - Stamped rounded head
 - 4 way (front & back/side-to-side) head pivot
 - 6° side-to-side head pivot
 - King pin indicator
 - Increased king pin contact design
 - Wider 9" king pin funnel area
 - Forged single jaw
 - Self-latching jaw design
- Limited Lifetime Warranty



Part No.	Description	Vertical Adjustment
30081	Reese® 20K Fifth Wheel	13-1/4" – 17"
30083	Reese® 20K Fifth Wheel with round tube slider	15-1/4" – 17-3/4"
30084	Reese® 20K Fifth Wheel with square tube slider	14-3/4" – 17-1/4"

Rails and installation kit must be ordered separately (#30035).

Note: Will not fit trucks with beds shorter than 6' in length unless used with Sidewinder™. Will not fit trucks with flareside/stepside.



30054

REESE® 30K FIFTH WHEEL LOW PROFILE HITCH

- 30,000 lbs. capacity; 7,500 lbs. pin weight capacity
- Low profile design can be vertically adjusted 3" to permit level trailering (9-1/2" to 12-1/2") above vehicle deck
- Side-tilt design reduces vehicle frame stress, creating a smoother, more comfortable ride and making hook-up and un-hook much easier
- Specially designed and engineered for the serious tower, primarily on medium-duty conversion trucks
- Actuating handle is more easily accessible than most fifth wheels, making hook-up quicker and more convenient
- Limited Lifetime Warranty



Part No.	Description	Vertical Adjustment
30054	Reese® 30K Fifth Wheel Complete Base rails not used with this model. Mounts directly to medium-duty truck.	9-1/2" to 12-1/2"

Note: Will not fit trucks with beds shorter than 6' in length unless used with Sidewinder™. Will not fit trucks with flareside/stepside.

REESE® 22K FIFTH WHEEL

Features side-to-side pivot to better accommodate hook-ups on uneven ground. Quick installation, strong, reliable performance and easy removal to allow full truck bed access.

- 22,000 lbs. capacity; 5,500 lbs. pin weight capacity
- Two-jaw locking system
- Fore-and-aft and side-to-side pivot
- Locking jaw handle
- Solid base assembly for superior stability
- Requires rails & installation kit (sold separately)
- Limited Lifetime Warranty



30033

Part No.	Description	Vertical Adjustment
30033	Reese® 22K Fifth Wheel	13" to 17"

Rails and installation kit must be ordered separately (#30035).

Note: Will not fit trucks with beds shorter than 6' in length unless used with Sidewinder™. Will not fit trucks with flareside/stepside.

REPLACEMENT PARTS

Part No.	Description
30730	22K Base Assembly with adj. brackets (Reese®)
58099	22K Head only (Reese®)
58385	22K Adjustment bracket



Includes 90° Wire Harness 50-97-410

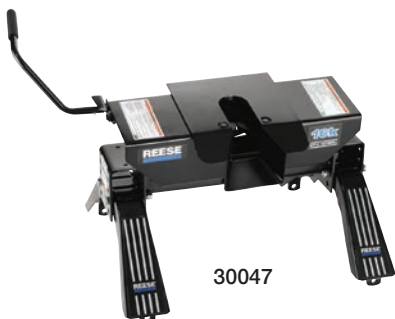

30047

REESE® 16K FIFTH WHEEL

Featuring side-to-side pivot action to better accommodate hook-ups on uneven ground. Quick-easy installation, strong performance and easy removal in just seconds to allow full access to the truck bed.

- 16,000 lbs. capacity; 4,000 lbs. pin weight capacity
- Two-jaw locking system
- Fore-and-aft and side-to-side 4°-5° pivot
- Locking jaw handle
- Wide stance one-piece legs for improved stability
- Requires rails & installation kit (sold separately)
- Limited Lifetime Warranty



Part No.	Description	Vertical Adjustment
30047	Reese® 16K Fifth Wheel	13-1/2" to 17"
30051	Reese® 16K Fifth Wheel with square tube slider	14-3/4" to 17"
30075	Reese® 16K Fifth Wheel with round tube slider	15-1/2" to 17-3/4"

Rails and installation kit must be ordered separately (#30035).

Note: Will not fit trucks with beds shorter than 6' in length unless used with Sidewinder™. Will not fit trucks with flareside/stepside.

REPLACEMENT PARTS



30727

Part No.	Description
30047A	Head with Head Support & hardware
58146	Fifth Wheel Head only (service kit)
58147	Cross Member – head support only
30727	Fifth Wheel Legs only (set of two)
58521	16K Head Assembly Hardware (Contains: (1) Cotter Pin, (2) Rubber Bumpers, (4) Locknuts 1/2"-13, (4) Hex Bolt 1/2"-13 x 4-1/2" GR5, (2) Nuts 8-32, (4) Spring Clips, (2) Machine Screws 8-32 x 1" & (4) Pull Pins)

25,000 LBS. FIFTH WHEEL HITCH

- Rated for 25,000 lbs. capacity / 6,250 lbs. pin weight capacity
- Grease grooves in the top of the skid plate
- Features a king pin funnel for easier hooking and unhooking
- Answers to the trend of higher towing capacities by vehicle manufacturers
- Dual jaw system completely surrounds the king pin for significantly reduced wear
- Attaches to the widest slots on the universal rail kits
- Limited lifetime warranty



30862

Part No.	Description	Vertical Adjustment
30862	25K Fifth Wheel Hitch	13-1/4" to 16-3/4"



30118



30119



30132

20,000 LBS. FIFTH WHEEL HITCHES

- 20,000 lbs. capacity; 5,000 lbs. pin weight capacity
- Full floating head for improved hooking and unhooking, as well as ride
- Dual jaw system completely surrounds the king pin for significantly reduced wear
- Lubricated and clamped side joints for tight and efficient operation
- Lightweight, easy to install and remove
- Sturdy, robust and reliable
- One-piece formed legs, provides a wider footprint for superior stability
- Sidewinder compatible, preferred for short bed pickups
- Compatible slider system available
- Best value in marketplace, more combination options
- Limited lifetime warranty



Part No.	Description	Vertical Adjustment
30118	20,000 lbs. Fifth Wheel Hitch Head and Support <i>Legs, Rails, and Installation Kit sold separately</i>	—
30119*	20,000 lbs. Fifth Wheel Hitch Head, Support, and Legs <i>Rails and Installation Kit sold separately</i>	13-1/2" – 17"
30132*	20,000 lbs. Fifth Wheel Head, Support, Legs, and Rails (10 bolt)	14-1/2" – 17"

* Available in skid quantities of 16 (Example: 30120-016)

Note: Will not fit trucks with beds shorter than 6' in length unless used with Sidewinder™. Will not fit trucks with flareside/stepsides.

20,000 LBS. FIFTH WHEEL HITCHES WITH SQUARE TUBE SLIDER

Designed for shortbed trucks to provide clearance and prevent damage to truck and trailer in tight spaces at slow speeds

- 20,000 lbs. capacity; 5,000 lbs. pin weight capacity
- 10" travel front to back
- Adjustable with trailer attached
- Can be used with full size trucks
- Dual jaw system completely surrounds the king pin for significantly reduced wear
- Full floating head for improved hooking and unhooking, as well as ride
- Jaw handle with tab for optional padlock security (padlock not included)
- Wide stance one-piece legs for improved stability
- Limited lifetime warranty



30121



30133

Part No.	Description	Vertical Adjustment
30121*	20,000 lbs. Fifth Wheel Hitch Head, Support, and Slider <i>Rails and Installation Kit sold separately</i>	14-3/4" – 17-1/4"
30133*	20,000 lbs. Fifth Wheel Hitch Head, Support, Slider, and Rails (10 bolt)	15-3/4" – 18-1/4"

* Available in skid quantities of 16 (Example: 30121-016)

Note: Will not fit trucks with beds shorter than 6' in length unless used with Sidewinder™. Will not fit trucks with flareside/stepsides.



30854†



30855†



31859†

16,000 LBS. FIFTH WHEEL HITCHES

- 16,000 lbs. capacity; 4,000 lbs. pin weight capacity
- Full floating head for improved hooking and unhooking, as well as ride
- Dual jaw system completely surrounds the king pin for significantly reduced wear
- Lightweight, easy to install and remove
- One-piece formed legs, provides a wider footprint for superior stability
- Sidewinder compatible, preferred for short bed pickups
- Compatible slider system available
- Sturdy, robust and reliable
- Best value in marketplace, more combination options
- Limited lifetime warranty



Part No.	Description	Vertical Adjustment
30854†	16,000 lbs. Fifth Wheel Hitch Head and Support <i>Legs, Rails and Installation Kit sold separately</i>	—
30855†*	16,000 lbs. Fifth Wheel Hitch Head and Support and Legs <i>Rails, and Installation Kit sold separately</i>	13-1/2" – 17"
31859†*	16,000 lbs. Fifth Wheel Hitch Head, Support, Legs, and Rails (10 bolt)	14-1/2" – 18"

* Available in skid quantities of 16 (Example: 30856-016)

Note: Will not fit trucks with beds shorter than 6' in length unless used with Sidewinder™. Will not fit trucks with flareside/stepsides.

16,000 LBS. FIFTH WHEEL HITCHES WITH SQUARE TUBE SLIDER

Designed for shortbed trucks to provide clearance and prevent damage to truck and trailer in tight spaces at slow speeds

- 16,000 lbs. capacity; 4,000 lbs. pin weight capacity
- Dual jaw system completely surrounds the king pin for significantly reduced wear
- 10" travel front to back
- Adjustable with trailer attached
- Can be used with full size trucks
- Full floating head for improved hooking and unhooking, as well as ride
- Jaw handle with tab for optional padlock security (padlock not included)
- Wide stance one-piece legs for improved stability
- Limited 10 year warranty



30857†



31860†

Part No.	Description	Vertical Adjustment
30857†*	16,000 lbs. Fifth Wheel Hitch Head, Support, and Slider <i>Rails and Installation Kit sold separately</i>	14-3/4" – 17-1/4"
31860†*	16,000 lbs. Fifth Wheel Hitch Head, Support, Slider, and Rails (10 bolt)	15-3/4" – 18-1/4"

* Available in skid quantities of 16 (Example: 31860-016)

Note: Will not fit trucks with beds shorter than 6' in length unless used with Sidewinder™. Will not fit trucks with flareside/stepsides.

REPLACEMENT PARTS

Part No.	Description
58521†	Replacement Part, 16K Head Assembly Hardware (Contains: (1) Cotter Pin, (2) Rubber Bumpers, (4) Locknuts 1/2"-13 , (4) Hex Bolt 1/2"-13 x 4-1/2" GR5, (2) Nuts 8-32, (4) Spring Clips, (2) Machine Screws 8-32 x 1" & (4) Pull Pins)

† = Available while supplies last.



30099



30093

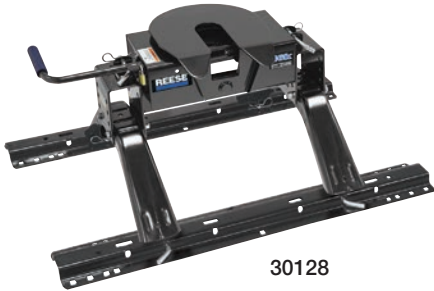

30128



30094

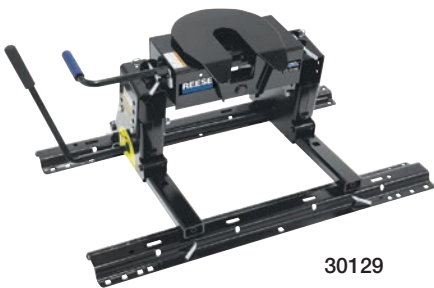

30129

16,000 LBS FIFTH WHEEL HITCHES

An economy fifth wheel hitch that doesn't act like one. The Reese® offers features only found in larger units. Installs and removes easily for full bed access.

- 16,000 lbs. capacity; 3,750 lbs. pin weight capacity
- Rounded slide bar mechanism designed for automatic latching with cushion grip handle
- 4-way pivoting head for easier hookup on uneven ground
- Jaw handle with tab for padlock security (padlock not included)
- Wide stance one-piece legs for improved stability
- Limited lifetime warranty



Part No.	Description	Vertical Adjustment
30099	16,000 lbs. Fifth Wheel Hitch Head, Support, Legs, Rails and Installation Kit sold separately	—
30093*	16,000 lbs. Fifth Wheel Hitch Head and Support and Legs Rails, and Installation Kit sold separately	12-1/2" – 16-1/2"
30128*	6,000 lbs. Fifth Wheel Hitch Head, Support, Legs, and Rails (10 bolt)	13-1/2" – 17-1/2"

* Available in skid quantities of 16 (Example: 30056-016)

Note: Will not fit trucks with beds shorter than 6' in length unless used with Sidewinder™. Will not fit trucks with flareside/stepside.

16,000 LBS. FIFTH WHEEL HITCHES WITH SQUARE TUBE SLIDER

Designed for shortbed trucks to provide clearance and prevent damage to truck and trailer in tight spaces at slow speeds. All 16,000 lbs. hitch features, plus -

- 10" travel front to back
- Adjustable with trailer attached
- Can be used with full size trucks
- Limited lifetime warranty



Part No.	Description	Vertical Adjustment
30094*	16,000 lbs. Fifth Wheel Hitch Head, Support, and Slider Rails and Installation Kit sold separately	14" – 16-3/4"
30129*	16,000 lbs. Fifth Wheel Hitch Head, Support, Slider, and Rails. (10 bolt)	15" – 17-3/4"

* Available in skid quantities of 16 (Example: 30076-016)

Note: Will not fit trucks with beds shorter than 6' in length unless used with Sidewinder™. Will not fit trucks with flareside/stepside.

FIFTH WHEEL HITCH - SERVICE KITS

Part No.	Description
58471	Head and pivot
58472	20K crossmember
58473	Handle assembly
58474	Pivot shaft, shaft nut and cotter pin
58475	20K hardware
58476	Head, pivot and handle
58484	Pivot pin

FIFTH WHEEL HEIGHT INFORMATION

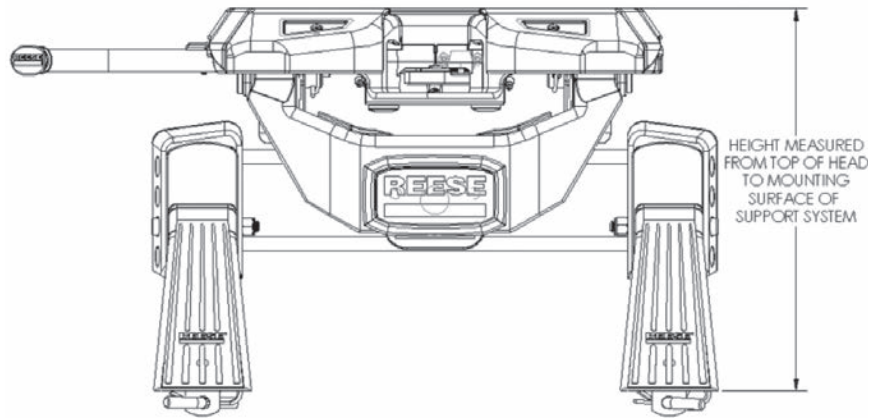

Figure 1 - Fifth Wheel Height Dimension Drawing

FIGURE 1 - FIFTH WHEEL HEIGHT INFORMATION

Part No.	Description	Maximum	Minimum
30871	Reese® 26.5K Elite™	17-1/2	15
30143	Reese® 25K Elite™	17	14-1/2
30142	Reese® 18K Elite™	18-1/4	14-1/2
30144	Reese® 18K Elite™ w/ Slider	19	16-1/2
30160	Reese® 20K Ram Drop In	18	14-1/4
30866†	Reese® 16K	17-3/4	13-3/4
30869†	Reese® 16K w/ Slider	19	16-1/4
30867†	Reese® 20K	18-1/4	14-1/4
30870†	Reese® 20K w/ Slider	19-1/2	16-3/4
30054†	Reese® 30K Low Profile	12-1/2	9-1/2
30033	Reese® 22K	17	13
30081	Reese® 20K	17	13-1/4

Part No.	Description	Maximum	Minimum
30083	Reese® 20K w/ Round Tube Slider	17 3/4	15-1/4
30084	Reese® 20K w/ Square Tube Slider	17-1/4	14-3/4
30047	Reese® 16K	17	13-1/2
30051	Reese® 16K w/ Square Tube Slider	17	14 3/4
30075	Reese® 16K w/ Round Tube Slider	17-3/4	15-1/2
30862	25K	16-3/4	13-1/4
30119	20K	17	13-1/2
30121	20K w/ Slider	17-1/4	14-3/4
30855†	16K	17	13-1/2
30857†	16K w/ Slider	17-1/4	14-3/4
30093	16K	16-1/2	12-1/2
30094	16K w/ Slider	16-3/4	14

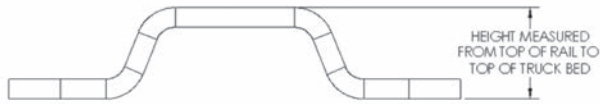

Figure 2 - Mounting Rail Height Dimensional Drawing

FIGURE 2 - RAIL HEIGHT INFORMATION

Part No.	Description	Height
58058	10 Bolt In Board Rail	1
30153	10 Bolt Out Board Rail	1-3/4
30126	Elite™ Rail Kit-Ford	0
30868	Elite™ Rail Kit-GM	0
30852	Elite™ Rail Kit-Dodge	0

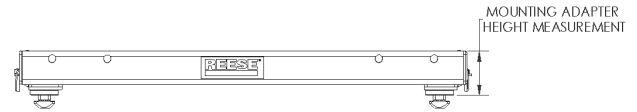
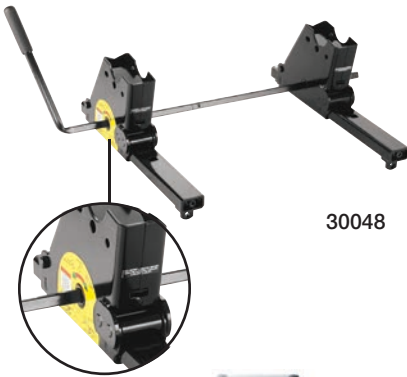

Figure 3 - Mounting Adapter Height Dimensional Drawing

FIGURE 3 - RAIL KIT MOUNTING ADAPTER HEIGHT INFORMATION

Part No.	Description	Height
30156	Ford OE/ Elite™ Rail Adapter	3-1/4
30154	Ram OEM Rail Adapter	2-3/4

† = Available while supplies last.



30048

SQUARE TUBE SLIDER (KWIK-SLIDE®)

- 6 roller design
- 10" travel fore-and-aft
- Works with full size trucks
- Fully adjustable with trailer attached
- Minimum 13" extended trailer pin box recommended
- Requires Fifth Wheel Mounting Rails (sold separately)
- Limited lifetime warranty

Part No.	Description
30048	Kwik-Slide® Slider Unit w/6 Rollers for 15K, 16K & 20K Head Assemblies (Requires Rails & Installation Kit #30035 or #30095 and Head Assembly)

Note: Check clearance between king pin bed and tailgate before moving to maneuvering position.



FIFTH WHEEL SLIDER UNIT W/ROLLERS

- 4 roller design
- 10" travel fore-and-aft
- Works with full size trucks
- Fully adjustable with trailer attached
- Minimum 13" extended trailer pin box recommended
- Requires Fifth Wheel Mounting Rails (sold separately)
- Limited lifetime warranty

Part No.	Description
30092	Fifth Wheel Slider Unit w/Rollers for 15K, 16K and 20K Head Assemblies (requires head assembly)

Note: Check clearance between king pin bed and tailgate before moving to maneuvering position.

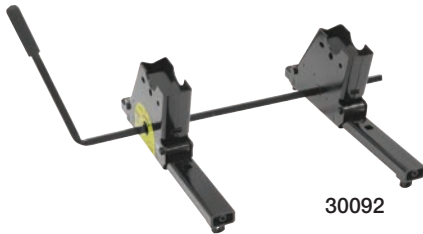

30092

Requires #30035 or #30095 universal base rail kit (sold separately)

25K ABOVE-BED GOOSENECK

- Easy installation and removal allows for full access to truck bed
- Utilizes same base rails as our fifth wheel hitches
- 2-5/16" high strength zinc plated ball
- In-truck platform rated for 25,000 lbs. gross vehicle towing weight and 6,250 lbs. vertical load
- Black powder coat finish
- Limited lifetime warranty

Part No.	Description	Capacity	Pin Capacity
58079	25K Gooseneck Hitch	25,000 lbs.	6,250 lbs.
58208	Chevrolet Composite Bed Kit for gooseneck		

Rails and installation kit must be ordered separately (#30035, 10-bolt or #30095, 4-bolt).



58079

25K ABOVE-BED GOOSENECK

- Easy installation and removal allows for full access to truck bed
- Utilizes same base rails (#30035 or #30095) as our fifth wheel hitches
- Raised safety chain locations all for easy trailer connection
- 2-5/16" high strength zinc ball
- In-truck platform rated for 25,000 lbs. gross vehicle towing weight and 6,250 lbs. vertical load
- Ball is offset 2" to accommodate 6 & 8 ft. truck beds
- Limited lifetime warranty

Part No.	Description	Capacity	Pin Capacity
49080	25K Gooseneck Hitch	25,000 lbs.	6,250 lbs.
58208	Chevrolet Composite Bed Kit for gooseneck		

Rails and installation kit must be ordered separately (#30035, 10-bolt or #30095, 4-bolt).



49080



83001
83002



83003†



83004



6011



30053



50223

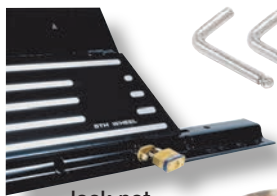

lock not included



58093



39072 / 39073



39074



63254

63251

ELITE™ & REESE® FIFTH WHEEL LUBE PLATES

Nylon lube plate protects fifth wheel plate from the wear of normal towing

- Eliminates the need for messy grease

Part No.	Description
83001	12" Lube Plate for use with Elite™ & Reese® 20K fifth wheel hitches only
83002	Fifth Wheel 10" Lube Plate for Reese® 16K & 22K fifth wheels
83003†	Fifth Wheel Lube Plate for Reese® Titan® 16K fifth wheels
83004	Titan® 16K Fifth Wheel 12" Thin Round Lube Plate, 1/8" Thick

FIFTH WHEEL LUBE PLATE

- Large surface for extra protection

Part No.	Description
6011	Fifth Wheel 10" Lube Plate for 16K and 22K Select Series™ & Reese® Fifth Wheels

FIFTH WHEEL ACCESSORY KIT

- Everything a new fifth wheel buyer needs to get started
- Lube, plate, cover, king pin lock, lock links

Part No.	Description
30053*	Fifth Wheel Starter Kit (for Reese® only)
30055*	Cover only

*Note: Does not fit Elite™ or 20K Reese®.

CHAIN BRACKET KIT

Fits Reese® fifth wheel rails and most popular brands. Provides secure attachment for trailer safety chains.

Part No.	Description
50223	Chain Bracket Kit, 18,000 lbs. each

PULL PIN LOCK PLATES

- Prevents theft of fifth wheel and unwanted removal of pull pins
- Add a standard padlock to make the locking plate a security device

Part No.	Description
58093	Pin Lock Plates for 1/2" pull pins for fifth wheels (4 pack)

CAPTURE PLATES

Part No.	Description
39072	AutoGlide Capture Plate, for Lippert 1621
39073	AutoGlide Capture Plate, for Lippert 1116 & 1716
39074	AutoGlide Capture Plate, for MORryde

FIFTH WHEEL LOCKS

Part No.	Description
KING PIN LOCKS	
63251	Fifth Wheel King Pin Lock, Extruded T6 Tempered Aluminum Body
RAIL LOCK	
63254	Fifth Wheel Rail Lock, Push Button, Replaces One Locking Pin

† = Available while supplies last.



30153



58503

FIFTH WHEEL RAILS & INSTALLATION KITS

Rails and installation kits for full-size trucks. Quick and easy installation with full truck bed access. For use on all fifth wheel hitches except Elite™ (formerly Signature Series).

FIFTH WHEEL MOUNTING RAILS

Part No.	Description
58058	Fifth Wheel Mounting Rails Only (10 - Bolt Design)
30153	Reese Outboard Fifth Wheel Mounting Rails Only (10 - Bolt Design)
58314	Mounting Brackets for Fifth Wheel Rails
58503	Fifth Wheel Mounting Rails Accessory, Corrugation Spacer Kit for #30035/#30153/#58058 (10 - Bolt Design)
58467	Replacement Part, Hole Style Pins (Qty. 4) & Clips (Qty. 4) for Reese Outboard Fifth Wheel Mounting Rails #30153



30035

FIFTH WHEEL INSTALLATION KITS

Part No.	Description
30035	Fifth Wheel Rails and Installation Kit, Includes Brackets and Hardware (10 - Bolt Design) (May Require Additional Kit - See Application Guide)
30035-040	Fifth Wheel Rails and Installation Kit, Includes Brackets and Hardware (10 - Bolt Design) (40 Pack) (May Require Additional Kit - See Application Guide)
30439	Installation Kit w/Hardware and Brackets for #30035, #58058 (10 - Bolt Design)
58023	Fifth Wheel Bracket Kit (Optional for #30035)
58166	Fifth Wheel Tube Spacer Kit (Optional for #30035)
58208	Chevrolet Composite Bed Kit for Above the Bed Rail Kit #30035 (10 - Bolt Design) used w/Select Series Fifth Wheels & 25K Above-Bed Gooseneck
58504	Replacement Part, Installation Hardware for #30035/#30153/#58058 (10 - Bolt Design) (Contains: (10) Carriage Bolt 1/2"-13 x 2" GR8, (10) Hex Nut 1/2"-13 GR5 & (10) Block 5/16" x 1" x 2")



Quick Install Bracket Kit

CUSTOM QUICK INSTALL BRACKETS AND KITS

- Vehicle specific Fifth Wheel Custom Quick Install Brackets available.
- Kits also available that include Fifth Wheel Mounting Rails and Vehicle Specific Brackets.



Universal Bracket Kit

UNIVERSAL FIFTH WHEEL ADAPTER BRACKETS

- Vehicle specific Universal Fifth Wheel Adapter Brackets available.
- Kits available for use with 4-Bolt and 10-Bolt Mounting Rail Kits.

FIFTH WHEEL CUSTOM QUICK INSTALL BRACKET & COMPLETE KIT
10 BOLT APPLICATION GUIDE



Make/Model	Style	Years	Brkt#	Rail#	ComboKit	NoDrill	FN
Chevrolet/GMC							
Silverado/Sierra 1500	(Classic)	99-07	50064	58058	50064-58	Ø	SW
Silverado/Sierra 1500	Does Not Fit MagneRide Magnetic Ride Suspension	07-17	50064	58058	50064-58	Ø	SW
Silverado/Sierra 1500 HD	(Classic)	01-07	50064	58058	50064-58	Ø	
Silverado/Sierra 2500		99-04	50064	58058	50064-58	Ø	
Silverado/Sierra 2500 HD		01-10	50064	58058	50064-58	Ø	
Silverado/Sierra 2500 HD		11-16	50066	58058	50066-58	Ø	
Silverado/Sierra 3500	(Classic)	01-07	50064	58058	50064-58	Ø	
Silverado/Sierra 3500 HD		07-10	50064	58058	50064-58	Ø	
Silverado/Sierra 3500 HD		11-16	50066	58058	50066-58	Ø	
Dodge/Ram							
Ram 1500	Except Mega Cab	02-08	50040	58058	50040-58	Ø	
Ram 1500	Mega Cab	06-08	50140	58058	50140-58	Ø	
Ram 1500	Except w/Air Suspension or 5.7 ft. Bed	14-17	50141	58058†	50141-58†	Ø	MB
Ram 1500		09-17	50142	58058	50142-58	Ø	SW
Ram 2500		03-09	50140	58058	50140-58	Ø	
Ram 2500	Except w/Gas Engines w/Overload Springs	10-10	50140	58058	50140-58	Ø	
Ram 2500	Except Mega Cab & w/Overload Springs	03-12	50040	58058	50040-58		
Ram 2500	Except w/Gas Engines w/Overload Springs	10-12	50140	58058	50140-58		
Ram 2500		14-17	50054	58058	50054-58	Ø	
Ram 3500		03-09	50140	58058	50140-58	Ø	
Ram 3500	Except Mega Cab & w/Overload Springs	03-12	50040	58058	50040-58		
Ram 3500	Except w/Gas Engines w/Overload Springs	10-12	50140	58058	50140-58		
Ram 3500		00-14	50085	58058	50085-58	Ø	
Ram 3500		13-16	50085	58058	50085-58	Ø	
Ford							
F-150		04-14	50081	58058	50081-58	Ø	SW
F-150		15-17	50087	58058	50087-58	Ø	SW
F-150 Heritage	Styleside	97-04	50042	58058	50042-58	Ø	
F-250	Styleside	97-99	50042	58058	50042-58	Ø	
F-250/350 Super Duty	Except Cab & Chassis	99-04	50043	58058	50043-58		
F-250/350 Super Duty	Except Cab & Chassis	99-10	50082	58058	50082-58	Ø	
F-250/350 Super Duty	Except Cab & Chassis	11-16	50026	58058	50026-58	Ø	
F-250/350 Super Duty	Single Rear Wheel, Except Cab & Chassis	17-17	50074	58058	50082-58		
F-450 Super Duty	Except Cab & Chassis	08-10	50082	58058	50082-58	Ø	
F-450 Super Duty	Except Cab & Chassis	11-16	50026	58058	50026-58	Ø	
Toyota							
Tundra		07-17	50084	58058	50084-58	Ø	SW

MB - Will not fit models equipped with air suspension package.

SW - Do not install on a truck with less than a 6' long bed unless the trailer is equipped with a Sidewinder pin box coupler #SW16K or #SW19K.

† = Available while supplies last.

UNIVERSAL FIFTH WHEEL RAIL KIT & ADAPTER BRACKET
APPLICATION GUIDE



Make/Model	Style	Years	Rail#	Required	FN
Chevrolet/GMC					
C/K Series		73-00	30035		
Silverado/Sierra 1500	(Classic)	99-07	30035		
Silverado/Sierra 1500		07-17	30035		
Silverado/Sierra 1500 HD	(Classic)	01-07	30035		
Silverado/Sierra 2500		99-04	30035		
Silverado/Sierra 2500 HD		01-16	30035		
Silverado/Sierra 3500	(Classic)	01-07	30035		
Silverado/Sierra 3500 HD		07-16	30035		
Dodge/Ram					
D Series		73-93	30035		
Dakota		94-04	30035		
Ram 1500		94-01	30035		
Ram 1500		02-08	30035	58023	
Ram 1500		09-12	30035	58386	SW
Ram 1500	Except w/Air Suspension or w/ECODiesel Engine	13-17	30035	58386	MB,SW
Ram 1500	Except w/Air Suspension	14-17	30035	58523	MB,SW
Ram 2500		94-02	30035		
Ram 2500	w/Overload Springs	03-12	30035	58186	
Ram 2500	Except w/Overload Springs	03-13	30035	58023	
Ram 2500		14-17	30035	58522	
Ram 3500		94-02	30035		
Ram 3500	w/Overload Springs	03-12	30035	58186	
Ram 3500	Except w/Overload Springs	03-12	30035	58023	
Ram 3500		13-14	30035	58520	
Ford					
F-100		75-83	30035		
F-150		75-96	30035		
F-150	Styleside, Except SuperCrew	97-03	30035		
F-150		04-14	30035	58426	
F-150		15-17	30035	58531	
F-150 Heritage	Styleside	04-04	30035		
F-250/350		75-96	30035		
F-250/350	Heavy Duty	77-97	30035		
F-250/350	Styleside	97-99	30035		
F-250/350 Super Duty	Except Cab & Chassis	99-16	30035		
F-450 Super Duty	Except Cab & Chassis	08-16	30035		
Nissan					
Titan		04-15	30035	58405	SW
Toyota					
Tundra	Regular Cab 8 ft. Bed	00-06	30035	58197	
Tundra		07-17	30035	58309	SW

MB - Will not fit models equipped with air suspension package.

SW - Do not install on a truck with less than a 6' long bed unless the trailer is equipped with a Sidewinder pin box coupler #SW16K or #SW19K.



REESE®
OVER 64 YEARS OF INNOVATION

GOOSENECK HITCH SYSTEMS

GOOSENECK COUPLER FOR RV'S

16K Goose Box™3
 20K Goose Box™3
 Goose Box™ Accessory Parts.3

ELITE™ GOOSENECK HITCH SYSTEMS

Elite™ Gooseneck Complete Hitch.4
 Elite™ Gooseneck Head with Pop-In™ Ball.4
 Elite™ Gooseneck Application Guide.5
 Elite™ Pop-In™ Ball Kit.6
 Elite™ Series Above-Bed Gooseneck.6

REESE® ABOVE-BED GOOSENECK

25k Gooseneck Hitch.6

DRAW-TITE® GOOSENECK HITCH SYSTEMS

30K Hide-A-Goose™ Hitch Head7
 25K Fold-Down Gooseneck Hitch Head.7
 30K Remov-A-Ball Gooseneck Hitch Head.8
 Hi-Rise™ Conversion Hitch.8
 25K Above-Bed Gooseneck.8
 Draw-Tite® Gooseneck Application Guide.9

REESE® GOOSENECK HITCH SYSTEMS

25K Above-Bed Gooseneck.10

GOOSENECK HITCH ACCESSORIES

U-Bolt Safety Chain.10
 2-5/16" Hitch Ball.10
 3" Hitch Ball.10
 Gooseneck Head U-Bolt Kits.10
 Magnetic Cover for Hide-A-Goose™.10
 Magnetic Cover for Remov-A-Ball®.10
 2-5/16" Ball for Remov-A-Ball®.10
 Gooseneck Installation Templates.10
 Hole Saw.10

GOOSENECK STANDARDS

Gooseneck GTW.11
 International Standards.12

FEATURED PRODUCTS



94623

20K GOOSE BOX™ GOOSENECK COUPLER FOR LIPPERT

- World's first OE approved gooseneck adapter
- 5th Airborne™ expertise reduces stress transferred to the RV frame



30845

ELITE™ SERIES ABOVE-BED GOOSENECK

- Rated for 25,000 lbs. capacity
- Specifically designed for the Professional tower who employs both fifth wheel and gooseneck trailers



9460

30K HIDE-A-GOOSE™ GOOSENECK HITCH HEAD

- Allows full use of pick-up bed area when hauling cargo
- Accommodates all standard vehicle suspensions



6300

30K REMOV-A-BALL® GOOSENECK HITCH HEAD

- 2-5/16" high strength zinc plated ball standard
- Spring loaded chrome sliding pin insures positive ball lock



30137

REESE® ELITE™ POP-IN BALL KIT™

- Ball rated for 30,000 lbs. capacity.
- Hole cover keeps Pop-In™ ball sleeve free of debris.



30138-26

REESE® ELITE™ UNDER-BED GOOSENECK HITCH

- Fifth wheel ready uses 4 holes to mount a fifth wheel hitch.

GOOSE BOX™ GOOSENECK COUPLER FOR RV'S

SAY YES, TO GOOSE BOX™!



Tests were conducted on a traditional pin box, existing gooseneck extension adapters, and the Goose Box™. The results were conclusive!



"The Goose Box is a great solution for fifth-wheel RV users who prefer to use gooseneck hitches," said Jason Lippert, CEO of Lippert Components. "We are very pleased with the results of the thorough testing of the Goose Box, which demonstrates that it is compatible with our RV frame. As a result, the proper installation of a Goose Box pin box will be acceptable under our RV frame warranty." – Lippert Press Release

After reviewing the Bosch Test reports for the Reese Goose Box™, Lippert Components (the world's largest manufacturer of RV frames) accepts the Goose Box for the towing of RVs with gooseneck hitches. "Proper installation of a Goose Box in its intended application will not void the chassis warranty when installed on a coach either by the OEM or in the aftermarket." – Jarod Lippert, Director of Marketing

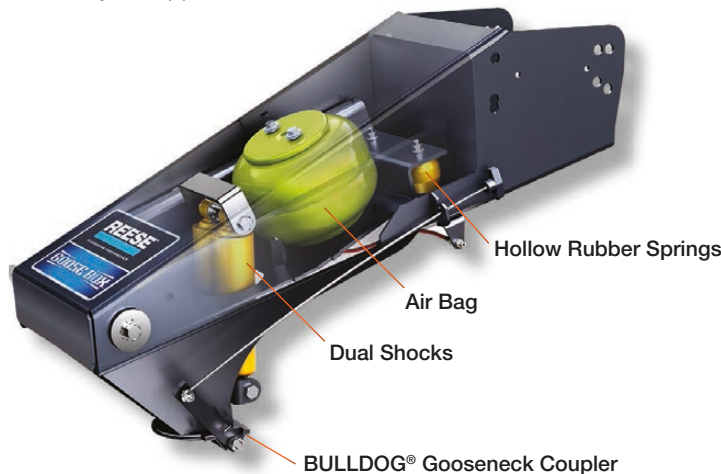

STEP UP TO RV COMFORT AND KEEP YOUR GOOSENECK HITCH!

Take the heavy equipment out of the truck bed! The Goose Box™ gooseneck coupler is specifically designed for RV trailer owners who wish to tow with their gooseneck hitch. The Reese® Goose Box™ replaces a traditional pin box so the RV works with the truck gooseneck hitch. Includes 5th Airborne™ technology for a superb ride.

- World's first OE approved gooseneck adapter, Endorsed by Lippert Components, Inc. for their frame systems
- Fits Lippert #1621 and #1716 wing sets
- 5th Airborne™ expertise reduces stress transferred to the RV frame
- Independent lab tested & proven to provide a better ride than king pin "bolt-on" adapter solutions (Bosch Automotive Proving Grounds)
- BULLDOG® gooseneck coupler technology with traditional king pin styling
- Air bag, dual shocks and hollow rubber springs provide multi-directional shock absorption for a smoother driving experience
- Air pressure relief valve prevents overfilling of air bag
- Available in bulk or individual packaging
- Rated for 16K & 20K lbs. capacity utilizing both CSA & SAE J2638 test standards
- Limited Lifetime Warranty



Part No.	Description
94622	Goose Box™ 16K Rated, For Lippert #1621 & #1716 Wing Sets (carton)
94623	Goose Box™ 20K Rated, 2-5/16" Gooseneck RV Coupler For Lippert #1621 & #1716 Wing Sets (Boxed & Purchased Individually)
ACCESSORY PARTS	
49150	Safety Chain Kit (Contains: (2) Grade 70, 5/16" x 44" w/ 5/16" Clevis Hook & Mounting Hardware)
49151	20K Safety Chain Kit (Contains: (2) Grade 70, 5/16" x 44" w/ 5/16" Clevis Hook & Mounting Hardware)
61301	Spacer Kit

Fits wing set Make and Model #: - Lippert #1621 - Lippert #1621 HD - Lippert #0719 - Fabex PB-600 Series

Spacer kit (#61301) required for installation on: - Lippert #1716 - Lippert #1116 - Lippert #0115

Patent Pending.

ELITE™



30138-26



30138



30158



30158-68

REESE® ELITE™ UNDER-BED GOOSENECK HITCH

REESE®

- Easy Under-Bed bolt-in installation
- Rated for 25,000 lbs. gross weight capacity*
- Passes SAE J2638, the toughest industry standard
- Pop-In™ Ball – lever inside ball head activates ball bearing locking system, lift and turn lever to unlock and remove ball
- Two safety chain holders attach directly to rail system
- Fifth wheel ready uses outer four holes to mount a fifth wheel hitch
- Hole cover keeps Pop-In™ Ball sleeve free of debris
- Storage bag included
- Patented and Patents Pending



Aligns to center hole in 2011-2015 Ford F-250 / F-350 / F-450 truck beds

Part No.	Description
30138-26	Elite™ Gooseneck Complete Hitch (includes #30126 rail and Pop-in™ ball kit)
30138	Elite™ Gooseneck Head with Pop-In™ 2-5/16" Ball (use with #30126 rail kit)

**Your actual weight capacity is limited to the towing vehicle or gooseneck rail kit capacity.*

2011-2016 Chevrolet Silverado / GMC Sierra 2500 & 3500 HD pickups

Part No.	Description
30158-68	Elite™ Gooseneck Complete Hitch (includes #30868 rail and Pop-in™ ball kit)
30158	Elite™ Gooseneck Head w/Pop-In™ 2-5/16" Ball (use w/#30852 or #30868 rail kit)

**Your actual weight capacity is limited to the towing vehicle or gooseneck rail kit capacity.*

2010-2012 Dodge / Ram 2500 & 3500 HD pickups

Part No.	Description
30158-52	Elite™ Gooseneck Complete Hitch (includes #30852 rail and Pop-in™ ball kit)
30158	Elite™ Gooseneck Head w/Pop-In™ 2-5/16" Ball (use w/#30852 or #30868 rail kit)

**Your actual weight capacity is limited to the towing vehicle or gooseneck rail kit capacity.*



30158-52



FIFTH WHEEL READY!





ELITE™ GOOSENECK APPLICATION GUIDE



Make/Model	Style	Years	Rail#	Head#	ComboKit
Chevrolet/GMC					
Silverado/Sierra 2500 HD		11-16	30868	30158	30158-68
Silverado/Sierra 3500 HD		11-16	30868	30158	30158-68
Dodge/Ram					
Ram 2500		10-12	30852	30158	30158-52
Ram 3500		10-12	30852	30158	30158-52
Ford					
F-250/350 Super Duty	Except Cab & Chassis	11-15	30126	30138	30138-26
F-450 Super Duty	Except Cab & Chassis	11-15	30126	30138	30138-26

ELITE™



30137

Lever inside ball head activates ball bearing locking system



30135



30134



58468



19311



30136



19315



19314



30845

For use with Elite™ rail kits only



58419



58079

ELITE™ POP-IN™ BALL KIT

- Pop-In™ Ball – lever inside ball head activates ball bearing locking system, lift and turn lever to unlock and remove ball
- Two safety chain holders
- Hole cover keeps Pop-In™ Ball sleeve free of debris
- Storage bag included
- Ball rated for 30,000 lbs. capacity*
- Patents Pending



Part No.	Description
30137	Elite™ Pop-In™ Ball Kit (Includes: (1) 2-5/16" Pop-In™ Ball #19311, (1) Storage Bag, (2) Safety Chain Attachments & (1) Hole Cover)
30136	Replacement Part, Hole Cover for Elite™ Under-Bed Gooseneck Hitch
30134	Replacement Part, Safety Chain Attachment for Elite™ Under-Bed Gooseneck Hitch (1 pack)
58468	Replacement Part, Safety Chain Attachment for Elite™ Under-Bed Gooseneck Hitch (2 pack)
30135	Replacement Part, Storage Bag for Elite™ Under-Bed Bolt-On Gooseneck 2-5/16" Pop-In Ball #19311
19311	Replacement Part, 2-5/16" Pop-In™ Ball for Elite™ Under-Bed Gooseneck Hitch
19315	1" High Rise, 2-5/16" Pop-In™ Ball for Elite™ Under-Bed Gooseneck Hitch
19314	3" Pop-In™ Ball for Elite™ Under-Bed Gooseneck Hitch
30140	Elite™ Series Under-Bed Gooseneck Accessories Kit, RAM OEM Kit Only (Includes: 2-5/16" Pop-In™ Ball #19311, Storage Bag, Safety Chain Attachments & Hole Cover)
30145	Replacement Part, Safety Chain Attachment (Qty. 1) for Elite™ Under-Bed Bolt-On Gooseneck, RAM OEM Kit Only

*Your actual weight capacity is limited to the towing vehicle or gooseneck rail kit capacity.

ELITE™ SERIES ABOVE-BED GOOSENECK

- Rated for 25,000 lbs. capacity
- 2-5/16" high strength zinc plated ball
- Specifically designed for the Professional tower who employs both fifth wheel and gooseneck trailers
- Utilizes the same vehicle specific under-bed rail kit system as the Elite™ fifth wheel
- Above-Bed Gooseneck can be easily removed for unobstructed use of the truck bed
- Weather resistant plastic covering provides protection from the elements and aesthetic appeal
- Built-in chain bracket to accommodate safety chain



Part No.	Description
30845	25K Elite™ Series Gooseneck
58419	Service kit adapter for Signature Series Fifth Wheels & Goosenecks when used on Elite™ Rail Kits (#30126 & #30868) & Ford OEM rail kits

Note: Will not fit trucks with beds shorter than 6' in length. Will not fit trucks with flareside/stepsides.

25K ABOVE-BED GOOSENECK

- Easy installation and removal allows for full access to truck bed
- Utilizes same base rails as our fifth wheel hitches
- 2-5/16" high strength zinc plated ball
- In-truck platform rated for 25,000 lbs. gross vehicle towing weight and 6,250 lbs. vertical load
- Black powder coat finish



Part No.	Description	Capacity	Pin Capacity
58079	25K Gooseneck Hitch	25,000 lbs.	6,250 lbs.
58208	Chevrolet Composite Bed Kit for gooseneck		

Rails and installation kit must be ordered separately (#30035, 10-bolt).



GOOSENECK SYSTEM

Draw-Tite has designed a Gooseneck Hitch System to meet your gooseneck towing needs. The secret of the system is in the rail kit. We've designed rail kits to fit your specific truck that can attach to your choice of the Hide-A-Goose, Fold-Down or Remov-A-Ball® heads. Easy install, reliable service.

SAME RAIL KIT - 3 METHODS OF ATTACHMENT

Use fit guide below and select your vehicle.

Option #1 Hide-A-Goose – ball stores in truck bed.

Option #2 Fold-Down – ball folds down in truck bed.

Option #3 Remov-A-Ball® – ball removes and is stored separately.



Hide-A-Goose



Fold-Down



Remov-A-Ball



30K HIDE-A-GOOSE™ GOOSENECK HITCH HEAD

- Allows full use of pick-up bed area when hauling cargo
- No alteration of OE exhaust systems required
- Accommodates all standard vehicle suspensions
- 2-5/16" high strength chrome plated ball standard, 3" ball optional
- Magnetic cover protects ball hole when not in use
- Rated up to 30,000 lbs. gross trailer weight and 7,500 lbs. vertical load, tested to SAE J2638 Static and Reese® Dynamic Specs for 30,000 lbs. gross vehicle weight rating
- Rail kits are rated to match manufacturer's vehicle weight ratings
- Spring loaded safety chain loops included
- Requires installation rail kit



9460
9464



9465



9466



9467



8339



Part No.	Description	Capacity	Pin Capacity
9460	Hide-A-Goose™ Wide Hitch Head	30,000 lbs.	7,500 lbs.
9465	Hide-A-Goose™ Narrow Hitch Head	30,000 lbs.	7,500 lbs.
9464	Hide-A-Goose™ Wide Hitch Head	30,000 lbs.	7,500 lbs.
9466	Hide-A-Goose™ Hitch Head, Ram 3500	30,000 lbs.	7,500 lbs.
9467	Hide-A-Goose™ Hitch Head, Ram 2500	20,000 lbs.	5,000 lbs.

Note: See fit guide in Application Catalog.

25K FOLD-DOWN GOOSENECK HITCH HEAD

- Fold-Down design allows unrestricted use of the truck bed when not towing
- Takes only seconds to raise or lower the ball into position
- 2-5/16" high strength chrome plated ball standard
- Includes mounting hardware & integrated drop down spring loaded safety chain loops
- Oversize pull ring allows user to raise or lower the ball while wearing gloves
- Integrated grease fitting is visible & easily accessible
- Platform & ball rated for 25,000 lbs. gross vehicle towing weight and 6,250 lbs. vertical load
- Rail kits are rated to match manufacturer's vehicle weight ratings
- No alteration of factory exhaust systems required
- Requires installation rail kit

Part No.	Description
8339	Fold-Down Gooseneck Hitch Head



REMOV-A-BALL®



6300



30K REMOV-A-BALL® GOOSENECK HITCH HEAD

- Allows full use of pick-up bed area when hauling cargo
- No alteration of OE exhaust systems required
- Accommodates all standard vehicle suspensions
- 2-5/16" high strength zinc plated ball standard
- Spring loaded chrome sliding pin insures positive ball lock
- Lockable to prevent ball theft (lock not included)
- Magnetic cover protects ball hole and activating lever slot when not in use
- In-truck platform may be used with rail kits or installed on any vehicle providing adequate structure to secure the platform
- In-truck platform is rated for 30,000 lbs. gross trailer weight and 7,500 lbs. vertical load and tested to V.E.S.C.-19 specs for 30,000 lbs. gross vehicle weight rating
- Rail kits are rated to match manufacturer's vehicle weight ratings
- Spring loaded safety chain loops included
- Requires installation rail kit



Part No.	Description
6300	Remov-A-Ball® Gooseneck Hitch Head

HI-RISE™ CONVERSION HITCH

Converts a gooseneck hitch into a fifth wheel hitch.



9480



- 4-Way pivoting head with self latching jaw design
- 4 degree side-to-side pivot for better control
- Fifth wheel height adjustments (14-1/4" - 18")
- 2 Bolts for bed Height Adjustments
- Offset Legs enhance performance while braking
- Adjustable stabilizer strips fit bed corrugation pattern
- Lockable, extended length handle
- Not Rated for use with Reese Sidewinder™
- Only works with B&W gooseneck hitch and Reese (94XX) series heads utilizing (44XX) Series Rails
- 18K gross trailer weight / 4.5K pin weight capacity
- Limited 5 year warranty



Part No.	Description
9480	Hi-Rise™ Conversion Hitch

REPLACEMENT PARTS	
58438	Stabilizer Strips
117300	Eltie™ Fifth Wheel Head Kit

Your actual weight capacity is limited to the towing vehicle or gooseneck rail kit capacity

DRAW-TITE® GOOSENECK APPLICATION GUIDE

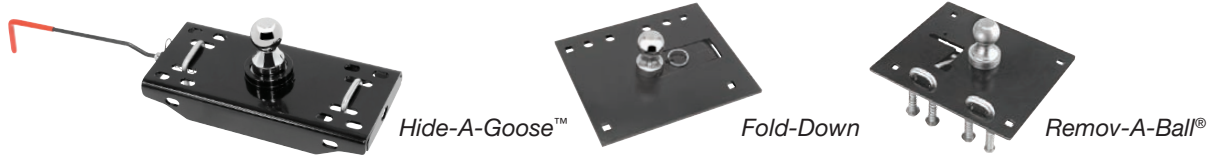

Make/Model	Style	Years	Rail#	FN	Head#	ComboKit	Fold-Down	Remov-A-Ball
Chevrolet/GMC								
C/K Series	Except Crew Cab	88-00	4440	KE	9465	9465-40	8339	6300
Silverado/Sierra 1500		99-17	4454	TV	9465	9465-54	8339	6300
Silverado/Sierra 1500 HD	(Classic)	01-07	4454		9465	9465-54	8339	6300
Silverado/Sierra 2500		99-04	4434		9465	9465-34	8339	6300
Silverado/Sierra 2500	6.6 ft. Bed	99-04	4454		9465	9465-54	8339	6300
Silverado/Sierra 2500 HD		01-10	4434		9465	9465-34	8339	6300
Silverado/Sierra 2500 HD		11-16	4456	KH	9465	9465-56	8339	6300
Silverado/Sierra 3500		01-07	4445		9465	9465-45	8339	6300
Silverado/Sierra 3500 HD		07-10	4434		9465	9465-34	8339	6300
Silverado/Sierra 3500 HD		11-16	4456	KH	9465	9465-56	8339	6300
Dodge/Ram								
Ram 1500		94-01	4439		9460	9460-39	8339	6300
Ram 1500	Except Mega Cab	02-08	4438		9464	9464-38	8339	6300
Ram 1500	Mega Cab	06-08	4435	JR	9464	9464-35	8339	6300
Ram 1500		09-10	4446		9464	9464-46	8339	6300
Ram 1500	Except w/Air Suspension	11-17	4446		9464	9464-46	8339	6300
Ram 2500		94-02	4439		9460	9460-39	8339	6300
Ram 2500		03-12	4435	JR	9464	9464-35	8339	6300
Ram 2500		10-13	4457	JR, TX	9464	9464-57	8339	6300
Ram 2500	(Gooseneck Head Does Not Require Rail Kit)	14-17			9467			
Ram 3500		94-02	4439		9460	9460-39	8339	6300
Ram 3500		03-12	4435	JR	9464	9464-35	8339	6300
Ram 3500		10-12	4457	JR, TX	9464	9464-57	8339	6300
Ram 3500	(Gooseneck Head Does Not Require Rail Kit)	13-16			9466			
Ford								
F-150		04-14	4437		9465	9465-37	8339	6300
F-150		15-15	4484†		9465	9465-84†		
F-150		15-16	4491		9465	9465-91		
F-250/350 Super Duty	Except Cab & Chassis	99-15	4448†		9460	9460-48†	8339	6300
F-250/350 Super Duty	Except Cab & Chassis	08-15	4449	JR	9460	9460-49	8339	6300
F-450 Super Duty	Except Cab & Chassis	08-15	4449	JR	9460	9460-49	8339	6300
Toyota								
Tundra		07-17	4436	JR, TV	9465	9465-36		

* Denotes Gooseneck Head Does Not Require Rail Kit
 JR = Exhaust must be temporarily lowered for installation.
 KE = Does not fit 88-91 4 Dr. Crew Cab models.
 KH = Minor heat shield modification may be required.
 † = Will not fit vehicles equipped with dual exhaust exiting below the bumper.
 TV = May require Offset Extension Ball #19308 on trucks with less than a 6' long bed.
 TX = This product has a higher load capacity.

† = Available while supplies last.



49080

Available in skid quantities of 24
(Example: 49080-024)

25K ABOVE-BED GOOSENECK

- Easy installation and removal allows for full access to truck bed
- Utilizes same base rails (#30035) as our fifth wheel hitches
- Raised safety chain locations all for easy trailer connection
- 2-5/16" high strength zinc ball
- In-truck platform rated for 25,000 lbs. gross vehicle towing weight and 6,250 lbs. vertical load
- Ball is offset 2" to accommodate 6 & 8 ft. truck beds
- Limited 5 year warranty



Part No.	Description	Capacity	Pin Capacity
49080	25K Gooseneck Hitch	25,000 lbs.	6,250 lbs.
58208	Chevrolet Composite Bed Kit for gooseneck		

Rails and installation kit must be ordered separately (#30035, 10-bolt).



GOOSENECK HITCH ACCESSORIES & REPLACEMENT PARTS

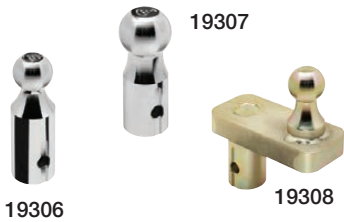

19306

19307

19308



5983



58389



58524

Part No.	Description
GOOSENECK REPLACEMENT PARTS	
6308	Replacement U-Bolt Safety Chain Kit
ABOVE-BED GOOSENECK REPLACEMENT PARTS	
19310	Replacement Gooseneck 2-5/16" Hitch Ball
UNDER-BED GOOSENECK REPLACEMENT PARTS	
19306	2-5/16" Hitch Ball w/1" Rise for 9460, 9465, and 9464 Gooseneck Heads
19307	3" Hitch Ball for 9460, 9465, and 9464 Gooseneck Heads
19308	2-5/16" Hitch Ball w/5" Offset for 9460, 9465, and 9464 Gooseneck Heads
19309	2-5/16" Hitch Ball for 9460, 9465, and 9464 Gooseneck Heads
58312	Gooseneck Head U-Bolt Kit for 946x Gooseneck Heads
58389	Round Replacement Magnetic Cover for Hide-A-Goose™
58524	Replacement Part, Cover for Hide-A-Goose™ Gooseneck (Only Works w/#9466 & #9467)
REMOV-A-BALL® HITCH HEAD REPLACEMENT PARTS	
5983	Rectangular Replacement Magnetic Cover for Remov-A-Ball®
5973	Replacement 2-5/16" Ball for Remov-A-Ball®

GOOSENECK INSTALLATION TEMPLATES

- Stainless steel cutting template for Fold Down installation

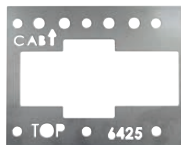

6425

Part No.	Description
6425	Fold Down Gooseneck Installation Template for #8339



58381

HOLE SAW

Part No.	Description
58381	3-1/2" Hole Saw

GOOSENECK HITCH SYSTEMS

Gooseneck Hitch Systems conveniently allow unrestricted use of the pickup bed. In-truck platforms support 2-5/16" and 3" hitch balls. All framework for Gooseneck Trailer Hitches reside under the bed of the truck with only the ball exposed above the bed of the truck. Stronger, and able to utilize the full suspension of the truck, Gooseneck Hitch Systems are rated up to full towing capacity of the vehicle as determined by the manufacturer. Draw-Tite Gooseneck Hitch Systems utilize a unique set of mounting rails, specific to each vehicle, that will accommodate any of the hitch heads.

HOW LARGE A TRAILER CAN I TOW?

Each truck has a published Gross Combined Weight Rating GCWR. This is the maximum allowable tow rating in terms of the combined vehicle and trailer weight. When the Gross Vehicle Weight GVW is subtracted, the maximum Gross Trailer Weight is revealed.

In this example, the maximum allowable trailer towing weight is 12,800 lbs. GTW. The rail kit for this vehicle has been tested to meet maximum vehicle tow capacity.

GCWR - GVW = MAX. GTW

2001 GMC Heavy Duty 2500, 4 Wheel Drive Extended Cab

Engine: Duramax 6600

Horsepower: 300 hp @ 3100 rpm

Torque: 520 ft. lbs. @ 1800 rpm

Transmission: Allison 5-speed Automatic

Axle Ratio: 3.73 to 1

GVW: 9,200 lbs.

GCWR: 22,000 lbs.

22,000 lbs. GCWR - 9,200 lbs. GVW = 12,800 lbs. GTW

COMMON TERMINOLOGY:

Base Curb Weight - The nominal weight of a vehicle with standard equipment and a full tank of fuel. It does not include passengers, cargo or optional equipment.

Commercial Towing - Any vehicle/trailer combination exceeding 26,000 lbs. Gross Combined Weight GCW.

Commercial Vehicle - Any vehicle that exceeds 10,000 lbs. GVW.

Gross Vehicle Weight (GVW) - The actual weight of the vehicle when fully loaded. It is the base curb weight plus the cargo weight.

Gross Vehicle Weight Rating (GVWR) - The maximum allowable weight of the fully loaded vehicle.

Gross Combined Weight (GCW) - The actual weight of the vehicle and trailer combined. This weight should always be obtained by weighing the vehicle and trailer together on a scale.

Gross Combined Weight Rating (GCWR) - The maximum weight of the towing vehicle and the loaded trailer - including cargo and passengers.

Gross Axle Weight (GAW) - The total weight supported by each axle (front or rear). To compute this weight for your vehicle and trailer combined, take the loaded vehicle and trailer to a scale. With the trailer attached, place the front wheels of the vehicle on the scale to obtain the front GAW. To obtain the rear GAW, weigh the towing vehicle with the trailer attached, but with just the four wheels of the vehicle on the scale. The rear GAW is determined by subtracting the front GAW from that amount.

Gross Axle Weight Rating (GAWR) - The total weight each axle is capable of carrying. The total load on each axle must not exceed its GAWR.

Gross Trailer Weight (GTW) - The weight of a trailer fully loaded.

Maximum Loaded Trailer Weight - The maximum allowable fully loaded weight of the trailer. This weight is obtained by subtracting the towing vehicle's GVW from its GCWR.

Payload - The combined maximum allowable weight of cargo, occupants and optional equipment that the vehicle is designed to carry. (Gross Vehicle Weight Rating minus the base curb weight.)

Rail Kit - The components and hardware that mount the gooseneck hitch to the vehicle frame.

THE SAE INTERNATIONAL J2638 STANDARD FOR GOOSENECK AND FIFTH WHEEL TRAILERS UNDER 30,000 LBS.



The Society of Automotive Engineers (SAE) is a non-profit educational and scientific organization dedicated to advancing mobility technology to better serve humanity. SAE has developed many standards, testing methods and procedures to measure the performance of vehicles and vehicle related products, including trailers. SAE J2638 addresses both gooseneck and 5th wheel trailers under 30,000 lbs. The testing methods for gooseneck are as follows:

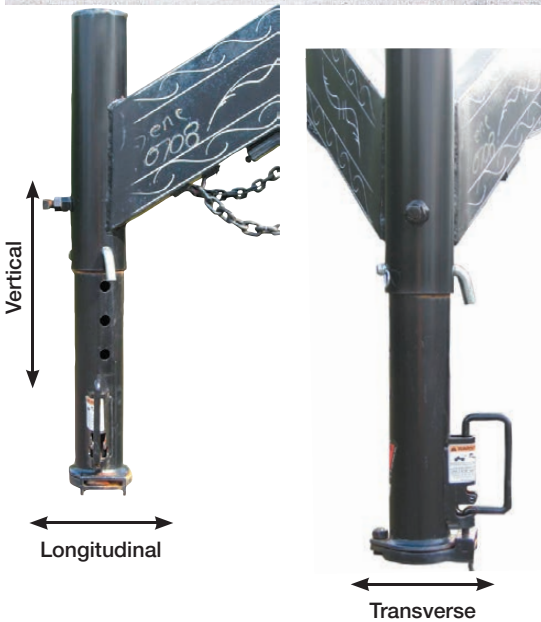

TESTING METHODS

STATIC TESTING is a one time maximum load requirement for the three test conditions.

The test is to be maintained for 5 Seconds.

- **Vertical** - tests the goosenecks ability with upward and downward pressure
 - 85% of GW Pull Out (25K lb Gooseneck = 21,250 lbs)
 - 50% of GW Down (25K lb Gooseneck = 12,500 lbs)
- **Longitudinal** - tests the goosenecks ability with front and back pressure
 - 75% of GW Front and Back (25K lb Gooseneck = 18,750 lbs)
- **Transverse** - tests the goosenecks ability with side to side pressure
 - 30% of GW Each Side (25K lb Gooseneck = 7,500 lbs)

DYNAMIC TESTING defines requirements for repetitive testing in the three test conditions.

- 300,000 Cycles in each test condition. (Vertical, Longitudinal and Transverse)
- The same unit is used for all three tests. (900,000 Cycles all together)
- The range of load requirements are based on GW and Rated Coupler Load.

In order to assure safety and accountability for the products produced, SAE J2638 also requires:

- Product Identification
 - Manufacturer's Name
 - Maximum Trailer GW
 - Rated Vertical Coupler Load
 - Ball Size
- Testing
 - Products are to be fixtured at the maximum stress conditions
 - There should be no loss of attachment during testing
 - When testing is completed, the coupler will be capable of being uncoupled and coupled



Competitor's 25K gooseneck fails longitudinal test at 11,500 lbs.

HORIZON GLOBAL COMMITMENT

As the leading manufacturer of gooseneck couplers, Horizon Global understands the importance of the new SAE standard for Goosenecks and 5th Wheels. We are committed to providing products that meet or exceed these recommendations and our commitment is evident by our investment in people and facilities dedicated to testing our products.

In addition to being one of the only manufacturers with dedicated testing facilities, Horizon Global also has over 90 years of manufacturing experience to insure our products are of the highest quality and reliability.

Because of the size of our organization we can provide the added benefits of high quality, unmatched reliability and proven strength, at a competitive price.



REESE®
THE BRAND OF CHOICE
ESTABLISHED 1952

PIN BOXES

GOOSENECK COUPLER FOR RV'S

16K Goose Box™.....	.3
20K Goose Box™.....	.3
Goose Box™ Accessory Parts.....	.3

PIN BOXES

Elite Airborne / Sidewinder™ Combo.....	.4
16K Sidewinder™.....	.5
19K Sidewinder™.....	.6
16K 5th Airborne™.....	.7
21K 5th Airborne™.....	.7

OE REPLACEMENT PIN BOX

10K Revolution Combo.....	.8
16K Revolution Combo.....	.8

PIN BOX ACCESSORIES

Custom Wedges.....	.9
--------------------	----



NEW PRODUCTS



61510

10K & 16K REVOLUTION COMBO OE REPLACEMENT PARTS

- Automatically eliminates turning and clearance headaches
- Make 90° plus turns without exiting the truck
- For OE Revolution pin boxes



31016

CUSTOM SIDEWINDER™ WEDGE KIT

- Designed to work with Sidewinder™ and Airborne / Sidewinder™
- Replacement wedge that is designed for Curt A16 Fifth Wheel

FEATURED PRODUCTS



61412

ELITE AIRBORNE / SIDEWINDER™ COMBO

- Enhances maneuverability and comfort
- 90-plus degree turning with a short bed truck
- SAE/CSA rated 16K



5AB-E1621-16K

5TH AIRBORNE™

- Premium fifth wheel air-ride pin box engineered and developed by long-time veterans of the towing industry
- One piece body design



SW19K

19K SIDEWINDER™

- Nimble and quick, worry-free turning
- Premium pin box designed specifically for short bed pickups



94622

GOOSE BOX™

- World's first OE approved gooseneck adapter, endorsed by Lippert Components, Inc
- Rated for 16K and 20K lbs. capacity

GOOSE BOX™ GOOSENECK COUPLER FOR RV'S



Step up to RV comfort and keep youR gooseneck hitch

Take the heavy equipment out of the truck bed! The Goose Box™ gooseneck coupler is specifically designed for RV trailer owners who wish to tow with their gooseneck hitch. The Reese® Goose Box™ replaces a traditional pin box so the RV works with the truck gooseneck hitch. Includes 5th Airborne™ technology for a superb ride.

- World's first OE approved gooseneck adapter, Endorsed by Lippert Components, Inc. for their frame systems
- Fits Lippert #1621 and #1716 wing sets
- 5th Airborne™ expertise reduces stress transferred to the RV frame
- Independent lab tested & proven to provide a better ride than king pin "bolt-on" adapter solutions (Bosch Automotive Proving Grounds)
- BULLDOG® gooseneck coupler technology with traditional king pin styling
- Air bag, dual shocks and hollow rubber springs provide multi-directional shock absorption for a smoother driving experience
- Air pressure relief valve prevents overfilling of air bag
- Available in bulk or individual packaging
- Rated for 16K & 20K lbs. capacity utilizing both CSA & SAE J2638 test standards
- Limited Lifetime Warranty



	OEM Part Numbers Lippert #1621 & #1716 Wing Sets	16K Rated Complete Part Number 94622	20K Rated Complete Part Number 94623	16K Rated Safety Chain 49150	20K Rated Safety Chain 49151

Fits wing set Make and Model #: - Lippert #1621 - Lippert #1621 HD - Lippert #0719 - Fabex PB-600 Series

Spacer kit (#61301) required for installation on: - Lippert #1716 - Lippert #1116 - Lippert #0115

Patent Pending.

ELITE AIRBORNE/SIDEWINDER™ COMBO



The best of both worlds

Reese® Elite™ pin boxes provide the smoothest ride of the best air-ride pin box on the market and automatically eliminates turning and clearance headaches.

- Provides all the benefits of both the Reese 5th Airborne air-ride pin box and the Reese Sidewinder pin box
- Enhances maneuverability and comfort
- Takes the worry and discomfort out of traveling with a fifth wheel trailer
- Durable, lasting design combines attractive look with optimal function
- 90-plus degree** turning with a short bed truck
- SAE/CSA rated 16K
- Limited Lifetime Warranty



***Warning: Not all vehicles and trailer combinations will allow a 90-plus degree turn.*

⚠ WARNING

Check Compatibility of Your Fifth Wheel Hitch with The Sidewinder™ or 5th Airborne Sidewinder™.

Refer to the specific product page for Sidewinder™ or 5th Airborne Sidewinder™ for up to date 5th Wheel Hitch Compatibility.

ELITE



16K Elite™ Airborne / Sidewinder™

OEM Part Numbers	Complete Part Number	Turret Part Number	Spacer Kit	Arm w/ King Pin	Rebuild Kit
Fabex 500 and 700 series Lippert 1116, 0115, 1716 RBW 7019, 7028	61412	61300	61301		
Febex 600 series M&M 663, 665 Lippert 0719, 1621 Lippert 1621 HD*	61422	61300	NA	5AS16K	94316
Venture CJ13515, CJ13517 Dexter 221-0033-00, 221-0031-00	61452	61302	NA		
Leland 7910, 7920, 7921	ST400-5AS16K	ST400	NA		

*Not to exceed 16K GTWR



16K SIDEWINDER™

Nimble and quick, worry-free turning

Reese® Sidewinder™, with a limited lifetime warranty, is the premium pin box designed specifically for short bed pickups. The nimble and quick design automatically eliminates turning and clearance headaches. Now you can make up to 90-degree plus* turns without exiting the truck. Without throwing a switch. Without pushing a button.

Sidewinder's king pin locking mechanism moves the pivot position 22" rear of the pin box's attachment point. This enables Sidewinder to handle up to a 90-degree plus turn effortlessly. By moving the pivot rearward while keeping the load centered over the axles, the trailer tracks more closely to the truck. This reduces the need for extra-wide turns and allows short bed pickups to jackknife with no fear of contact. And it's all done automatically. Sidewinder also offers faster steering wheel response, making backing up easier than ever before. The pivoting pin box makes hook up possible at any angle. And since the towing position of the pin box arm is locked in line with the truck, you can make full use of the truck bed space, giving you extra storage space for fuel tanks, toolboxes and cargo.

Don't let the slim looks fool you. Sidewinder has been built for strength. The C-channel design gives it more stability and strength than the standard pin box design. It also allows better load capacity and the ability to support heavier loads. Tested for real world conditions, Sidewinder has cleared rigorous testing by BOSCH automotive proving grounds and exceeds all SAE/CSA Standard 16K ratings requirements for RVs.



*WARNING: Not all tow vehicle and trailer combinations will allow a 90 degree turn

⚠ WARNING

Check Compatibility of Your Fifth Wheel Hitch with The Sidewinder™ or 5th Airborne Sidewinder™.

Refer to the specific product page for Sidewinder™ or 5th Airborne Sidewinder™ for up to date 5th Wheel Hitch Compatibility.



16K Sidewinder™

OEM Part Numbers	Complete Part Number	Turret Part Number	Spacer Kit	Arm w/ King Pin	Rebuild Kit
Fabex 500 and 700 series Lippert 1116, 0115, 1716 RBW 7019, 7028	61410	61300	61301		
Fabex 600 series M&M 663, 665 Lippert 0719, 1621 Lippert 1621 HD*	61420	61300	NA	SW16K	86005
Venture CJ13515, CJ13517 Dexter 221-0033-00, 221-0031-00	61450	61302	NA		
Leland 7910, 7920, 7921	ST400-SW16K	ST400	NA		

*Not to exceed 16K GTWR

19K SIDEWINDER™

Nimble and quick, worry-free turning

Reese® Sidewinder™, with a limited lifetime warranty, is the premium pin box designed specifically for short bed pickups. The nimble and quick design automatically eliminates turning and clearance headaches. Now you can make up to 90-degree plus* turns without exiting the truck. Without throwing a switch. Without pushing a button.

Sidewinder's king pin locking mechanism moves the pivot position 22" rear of the pin box's attachment point. This enables Sidewinder to handle up to a 90-degree plus turn effortlessly. By moving the pivot rearward while keeping the load centered over the axles, the trailer tracks more closely to the truck. This reduces the need for extra-wide turns and allows short bed pickups to jackknife with no fear of contact. And it's all done automatically. Sidewinder also offers faster steering wheel response, making backing up easier than ever before. The pivoting pin box makes hook up possible at any angle. And since the towing position of the pin box arm is locked in line with the truck, you can make full use of the truck bed space, giving you extra storage space for fuel tanks, toolboxes and cargo.

Don't let the slim looks fool you. Sidewinder has been built for strength. The C-channel design gives it more stability and strength than the standard pin box design. It also allows better load capacity and the ability to support heavier loads. Tested for real world conditions, Sidewinder has cleared rigorous testing by BOSCH automotive proving grounds and exceeds all SAE/CSA Standard 19K ratings requirements for RVs.



**WARNING: Not all tow vehicle and trailer combinations will allow a 90 degree turn*

⚠ WARNING

Check Compatibility of Your Fifth Wheel Hitch with The Sidewinder™ or 5th Airborne Sidewinder™.

Refer to the specific product page for Sidewinder™ or 5th Airborne Sidewinder™ for up to date 5th Wheel Hitch Compatibility.



OEM Part Numbers	Complete Part Number	Turret Part Number	Spacer Kit	Arm w/ King Pin	Rebuild Kit
Fabex 500 and 700 series Lippert 1116, 0115, 1716 RBW 7019, 7028	61411	61300	61301		
Fabex 600 series M&M 663, 665 Lippert 0719, 1621 Lippert 1621 HD* and 1621 SHD*	61421	61300	NA	SW19K	86005
Leland 7910, 7920, 7921	ST400-SW19K	ST400	NA		

**Not to exceed 19K GTWR*



5TH AIRBORNE™

Make your next getaway a breeze

Your fifth wheel takes a lot of abuse from turbulence caused by potholes, section dividers, bridge decks and heavily worn interstate highways. The 5th Airborne premium fifth wheel air-ride pin box acts as a buffer between the tow vehicle and the trailer, minimizing the challenges in the road. This significantly reduces the negative impact of vertical shock and longitudinal chocking. The 5th Airborne does more than improve your ride; it protects your investments by relieving stress on your coach's frame, cabinets, mechanicals, and support mechanisms. Furniture, appliances, TVs, computers, dishes, glassware and other fragile items stay in their places. Drivers and passengers also benefit from reduced fatigue and the improved safety provided by the 5th Airborne's smooth ride.

The 5th Airborne premium fifth wheel air-ride pin box was engineered and developed by long-time veterans of the towing industry.



**16K & 21K
5th Airborne™**



OEM Part Numbers	Complete Part Number	Complete Part Number
Lippert 1621*	5AB-E1621-16K	N/A
Fabex 500 Series STD. Lippert 1116, 0115 RBW 7019	N/A	5AB-S500-700
Leland 7910, 7920, and 7921	N/A	5AB-E7920
Fabex 500 Series EXT. and 765 Lippert 1716 RBW 7028	N/A	5AB-E510-710
Fabex 665 M&M 665 Lippert 1621, 1621 HD, 1621 SHD	N/A	5AB-E1621-610

*Excluding HD models

10K & 16K REVOLUTION COMBO



Replacement pin box for trailers with OE Revolution

Reese® Revolution, with a limited lifetime warranty, is designed specifically as a replacement for trailers mounted with OE Revolution pin boxes.

Reese® Revolution technology automatically eliminates turning and clearance headaches without the need of a slider. Now you can make up to 90-degree plus* turns without exiting the truck. Without throwing a switch. Without pushing a button.

Revolution also offers faster steering wheel response, making backing up easier than ever before. The pivoting pin box makes hook up possible at any angle. And since the towing position of the pin box arm is locked in line with the truck, you can make full use of the truck bed space, giving you extra storage space for fuel tanks, toolboxes and cargo.





**WARNING: Not all tow vehicle and trailer combinations will allow a 90 degree turn*





10K & 16K Revolution

OEM Part Numbers	Complete Part Number (No Wings)	Left Hand Wing	Right Hand Wing	Rebuild Kit
OE Trailers Mounted with 10K Reese® Revolution Pin Box	61510	61500	61501	86110
OE Trailers Mounted with 16K Reese® Revolution Pin Box	61516			86016

**Not to exceed 16K GTWR*

CUSTOM WEDGES

- Designed to work with the Sidewinder and Airborne / Sidewinder
- Replacement wedge that is designed for specific fifth wheel hitches

Part No.	Description
SWW-01	Custom Wedge for Elite™ Series & Reese® 20K Fifth Wheels
30850	Custom Wedge for Pro Series™ (Slide-Bar Style) Fifth Wheels
SWW-03	Custom Wedge for Reese® & Pro Series™ (Dual Jaw, except Titan®)16K Fifth Wheels
30865	Custom Wedge for Reese® Sidewinder Wedge Kit, Reese Titan Fifth Wheels
SWW-04	Custom Wedge for Original Husky Fifth Wheels
SWW-05	Custom Wedge for Hi-Jacker Fifth Wheels
SWW-06	Custom Wedge for B&W Fifth Wheels
SWW-07	Custom Wedge for RBW and Newer Husky Fifth Wheels
SWW-08	Custom Wedge for Colibert Fifth Wheels
SWW-09	Custom Wedge for PullRite Fifth Wheels
31016	Custom Wedge for Curt A16
30861	Custom Wedge for Curt E16



ROLA®

ADD ADVENTURE



CARGO MANAGEMENT

BIKE CARRIERS

TX™ / NV2™ Bike Carriers.	3
Q-Slot™ Bike Carriers.	4
Axis 3™ / Eclipse™ Bike Carriers.	5
Canyon™ Bike Carriers.	6
Bike Carrier Accessories.	6

CARGO CARRIERS

The Dart™ / Vortex™ Cargo Carriers.	7
Rambler™ / The Packer™ Cargo Carriers.	8
The Adventure System™.	9
Flathead™ Cargo Carriers.	9
Solo™ / Strongarm™ Cargo Carriers.	10
Vortex™ / Big Sky™ Cargo Carriers.	11
Cargo Tray Steel Hitch Mount.	11
The Bullet Box™ Cargo Carrier.	11
Cargo Carrier Lights / Accessories.	12

CARGO BAGS

Wallaroo™ Cargo Bag.	13
Amigo™ Cargo Bag.	13
The Tuffbak™ Cargo Bag.	13
Platypus™ Rooftop Cargo Bag.	13
Rainproof Rooftop Cargo Bags.	14
M.O.V.E.™ Organizers.	14

KAYAK CARRIERS

J-Rac™.	15
Hull-Hauler™ / Hull-Hugger™.	15

TRUCK RACK SYSTEMS

Truck Bed Racks.	16
V2 / V3 Van Racks.	16
Conduit Kit.	17
Top Rail Kit.	17
Load Stops / Eyebolts / Anchor Points.	18
Tool / Trimmer Racks.	18

ROOF RACKS

RBU Series Universal Roof Rack	19
Custom Roof Rack Systems.	19
Track Mount Roof Rack System.	20
Direct Mount Roof Rack Kits.	20
Roof Rack Application Guide.	21-28
Roof Rack Replacement Parts.	29

SECURING

Automotive Ratchet / Bungee Cords.	31-32
Tarp / Light Duty / Tow Straps	33
Titan Ratchet Tie Downs.	34
Marine Tie Downs.	35
Truck Nets.	36

NEW PRODUCTS

1390600



RATCHETING CARGO BAR

- Adjustable design ratchets from 40" - 70"
- Maximum hold, stops cargo from shifting

1041100



RAINPROOF, ROOFTOP CARGO BAG

- Constructed with quality rainproof material
- Easily attaches to raised side rails and/or crossbars

FEATURED PRODUCTS

59109



THE ADVENTURE SYSTEM™

- 250 lbs. maximum load capacity
- Removable cargo pod



Series 5940x

TX™ BIKE CARRIERS

- 2, 3 and 4 bike options available
- Tilts down even with bikes loaded when not in use

1394900



J-RAC™ KAYAK CARRIER

- 165 lbs. load capacity
- Foam pads cradle and protect your watercraft in the upright position

63152



THE RAMBLER™ CARGO CARRIER

- 500 lbs. capacity on 60" x 24" platform
- Rise shank design elevates cargo for improved ground clearance

TX™ BIKE CARRIERS

- Anti-sway rollers reduce bike movement during travel
- Tilts down (even with bikes loaded) for rear of vehicle access; arms fold down when not in use
- Integrated, retractable cable lock offers improved bike security
- Patented flip shank fits 1-1/4" and 2" receivers



Flip Shank
59400

Part No.	Description	Packaging
59400	TX-102, 2 Bike Carrier	Display Box
59403	TX-103, 3 Bike Carrier	Display Box
59401	TX-104, 4 Bike Carrier	Display Box

REPLACEMENT PARTS

Part No.	Description
59405	Replacement Part, TX Rubber Strap for 59400, 59403 or 59401
59406	Replacement Part, TX Cradle for 59400, 59403 or 59401
59407	Replacement Part, TX Anti Sway Cradle for 59400, 59403 or 59401



Flip Shank
59403



Fits 2"
Receivers
59401



Anti Sway Cradles



Built in Cable Lock



Tilts for Car Access

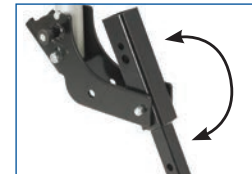

Flip Shank fits 1-1/4" and 2" Receivers

NV™ BIKE CARRIER

- Adjustable design accommodates both adult and children's bike sizes
- Designed to carry bikes by the wheels and not the frame
- Lightweight, durable aluminum support arms
- Support arms utilize multiple pivot points; stows upright for travel, extends to load bikes and folds flat for rear of vehicle access
- Foam pads protect bike frame and rims
- Carries up to two bikes
- Patented flip shank fits 1-1/4" and 2" receivers



59608

Part No.	Description	Packaging
59508	NV2™ Bike Carrier	Display Box



Adjustable Cradles

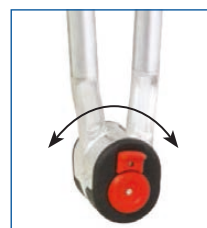

Moveable Arms



Flip Shank Fits 1-1/4" and 2" Receivers



Q-SLOT™ BIKE CARRIERS

- Adjustable design accommodates both adult and children's bike sizes
- Padded contact points secure bikes safely without damage to the frame
- Vertical stabilizer bar folds for easy storage; tilts forward, allowing rear bike access
- Rise shank – extra ground clearance for low riding cars
- Durable powder coat finish resists the elements, scratches and rust
- Versatile design fits both 1-1/4" and 2" receivers



63134
2 Bike



Post Tilts for
Bike Access

Part No.	Description	Packaging
63134	Q-Slot™ 2 Bike Carrier	Display Box
63138	Q-Slot™ 4 Bike Carrier	Display Box

REPLACEMENT PARTS

Part No.	Description
63135	Replacement Part, Bike Carrier Hook & Loop Straps for 63134 or 63138



63138
4 Bike



2 Bike Folded

4-BIKE CARRIER

- Narrow arms accommodate more bike styles and sizes
- Smart, swing-arm design tilts forward allowing rear vehicle access arms can be removed for compact storage
- Arms drop down when not in use
- Versatile design fits both 1-1/4" and 2" receivers



1393100G

Part No.	Description	Packaging
1393100G	4-Bike Carrier	Display Box



ECLIPSE™ BIKE CARRIER

- Accommodates most bike styles and sizes
- Smart, swing-arm design tilts forward allowing rear vehicle access
- Padded cradles secure bikes protecting the frame
- Smart hook and loop strap design offers superior support and promotes quick and easy loading & unloading
- Integrated rear reflector for nighttime visibility
- Fits 1-1/4" receivers (4-bike model fits 2" receivers)



63120
2 Bike

Part No.	Description	Packaging
63120	Eclipse™ 2 Bike Carrier, Fits 1-1/4" Receiver	Display Box
63123	Eclipse™ 3 Bike, Carrier Fits 1-1/4" or 2" Receiver	Display Box
63124	Eclipse™ 4 Bike, Carrier Fits 2" Receiver	Display Box

REPLACEMENT PARTS

Part No.	Description
63148	Replacement Part, Bike Carrier Cradle for 63120, 63123, 63124



63124
4 Bike



63123
3 Bike



63123 Has Flip Shank Fits 1-1/4" or 2" Receivers Patented.



1392900G

BIKE RACK TRUNK MOUNT

- Fits on most cars, mini vans and SUVs
- Lightweight aluminum frame
- Holds 2 bikes
- Six straps secure carrier to the vehicle
- High density foam pads protect vehicle

Part No.	Description	Packaging
1392900G	Bike Rack 2 Bike Trunk Mount	Display Box



1390300

AXIS 3™ TRUNK MOUNTED BIKE CARRIER

- Adjustable 3 bike trunk mount carrier
- Fits most cars ,minivans and SUVs
- Folds flat for storage when not in use
- High density foam pads and cushioned cradles you protect your bike and vehicle

Part No.	Description	Packaging
1390300	Reese Explorer Axis 3™ 3 Bike Carrier	Display Box



CANYON™ BIKE CARRIER

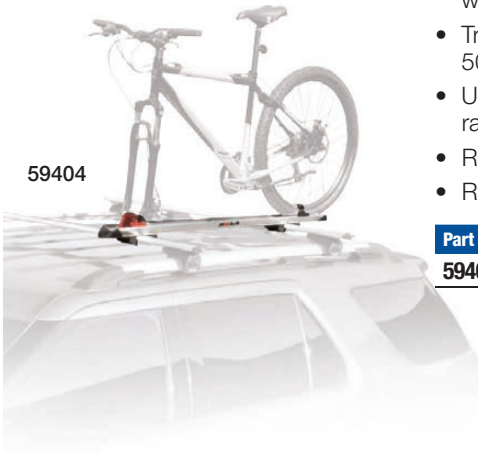

59404

- No contact to the bike frame; perfect for road bikes, mountain bikes--anything with standard fork-mount wheels
- Track design for fore/aft adjustability; works with children's and adult bikes up to 50" long from front fork to center of rear wheel
- Universal clamping design fits most ROLA®, OEM and other aftermarket roof racks
- Removable bushings accommodate small (5mm) and large (9mm) bike skewers
- Rugged, lightweight aluminum construction

Part No.	Description	Packaging
59404	Canyon™ Fork Mounted Roof Top Bike Carrier	Display Box



Quick Release Lever



Fits Wheels up to 3" Wide



Works with Disc Brakes



59904

DART™ FORK MOUNTED BIKE CLIP

- Works with your Dart™, Vortex™ or Rambler™ hitch basket
- Fork mounted bike clip
- Removable bushings accomodate small (5mm) and large (9mm) bike skewers

Part No.	Description	Packaging
59904	Dart™ Bike Mounting Adapter Kit	Display Box

PINHEAD™ HITCH PIN

- M12 Lock Pin for 59530†



59915

Part No.	Description	Packaging
59915	PinHead™ Hitch Pin	Bag w/Label



6145



BETTY BAR™ BIKE ADAPTER

- Installs to your seat post and stem to make any bike transportable

Part No.	Description	Packaging
6145	Betty Bar™ Bike Adapter	Clamshell

† = Available while supplies last.



THE DART™ CARGO CARRIER



59550

Reflector Kit Included!



59904

59531

- Robust 450 lbs. capacity 54" x 23" x 5-1/4" platform
- Ideal for bikes or extra gear
- Signature skid and side plates are constructed of rugged, high-impact abs and include built-in license plate relocation holes
- Rise shank design elevates cargo for improved ground clearance

Part No.	Description	Packaging
59550	The Dart™ Hitch Mount Basket	Display Box
59516	Waterproof LED Lights	Display Box
20174	Waterproof Incandescent Lights	Display Box
59904	Dart™ Bike Mounting Adapter Kit	Display Box
59531	Cargo Carrier Reflector Kit	Display Box



Folds Up When Not In Use



Carries Gear



Carries Bikes
(Optional bike clip 59904 not included)



Optional Brake, Turn & Running LED Light Kits 59516



Optional Brake, Turn & Running Incandescent Light Kits 20174

THE VORTEX™ CARGO CARRIER



Carries Bikes
(optional bike clip 59904 not included)

- 600 lbs. capacity (300 lbs. on 1-1/4" receiver model) on 56" x 23" platform: ideal for bikes or extra gear,
- 5-1/4" siderails keep your gear in place
- Rise shank design elevates cargo for improved ground clearance
- Convenient attachment points for relocating vehicle license plate
- Durable rough coat finish resists scratches and rust

Part No.	Description	Packaging
59502	The Vortex™ Cargo Carrier, Fits 2" Receivers, 600 lbs. Capacity	Display Box
59507	The Vortex™ Cargo Carrier, Fits 1-1/4" Receivers, 300 lbs. Capacity	Display Box
59531	Cargo Carrier Reflector Kit	Display Box

REPLACEMENT PARTS

Part No.	Description
59520	Replacement Part, hardware kit for the Vortex Hitch-Mounted Cargo Carrier



Carries Bikes
(optional bike clip 59904 not included)



THE RAMBLER™ CARGO CARRIER



- 500 lbs. capacity on 60" x 24" platform (300 lbs. capacity on 48" x 20" platform) ideal for bikes or gear
- 5.5" side rails keep cargo secure and in place
- Smart, rugged mesh floors make clean-up quick and easy
- Rise shank design elevates cargo for improved ground clearance
- Durable power coat finish resists the elements, scratches, and rust
- 1-1/4" and 2" receiver models available

Part No.	Description	Packaging
63152	The Rambler™ Cargo Carrier, 1 pc. Fits 2" Receivers, 500 lbs. Capacity, 60"x 24"	Display Box
63153	The Rambler™ Cargo Carrier, 2 pc. Fits 2" Receivers, 500 lbs. Capacity, 60"x 24"	Display Box
63154	The Rambler™ Cargo Carrier, 1 pc. Fits 1-1/4" Receivers, 300 lbs. Capacity, 48"x 20"	Display Box
63155	The Rambler™ Cargo Carrier, 2 pc. Fits 1-1/4" Receivers, 300 lbs. Capacity, 48"x 20"	Display Box
59531	Cargo Carrier Reflector Kit	Display Box

REPLACEMENT PARTS

Part No.	Description
63160	Replacement Part, Hardware Mounting Kit for Hitch-Mount Cargo Carriers (*#63152, #63153, #63154, and #63155)



59530†



6504

THE PACKER™ PRO CARGO CARRIER

- Robust 500 lbs. capacity on a 60" x 20" platform: ideal for camping, tailgating, or weekend getaways
- 3" siderails keep your coolers, bags, and other cargo secure and in place: includes holes for attaching bungee cords or cargo nets
- Smart, rugged mesh floors make clean-up quick and easy
- Durable powder coat finish resists the elements, scratches, and rust

Part No.	Description	Packaging
59530†	The Packer™ Pro Cargo Carrier, Fits 1-1/4" Receiver Mount w/2" Adapter, includes 1/2" & 5/8" pins & clips	Display Box
6504	Incandescent Light Kit	Display Box

REPLACEMENT PARTS

Part No.	Description
59915	Replacement Part, ROLA®, M12 Lock Pin for 59530†
59917	Replacement Part, ROLA®, 15MM Wrench for 59530†
59903	Replacement Part, APE Series Crossbar Hardware (Includes: (1) Hex Nut M8-1.25, (1) Clamp Block, (1) Flat Washer M8, (1) Lock Washer M8 & (1) Hex Bolt M8-1.25 x 20mm)

† = Available while supplies last.



THE ADVENTURE SYSTEM™

- Shoulders a robust 250 lbs. load capacity (150 lbs. capacity for 1-1/4" stationary model)
- Removable cargo pod fits perfectly into the hitch-mounted carrier and measures 54" x 30" x 22.5"; instantly adds over 13 cubic feet of added cargo space
- Carrier can be used without the cargo pod; ideal for coolers, bags or extra gear
- Tilt model folds upright for easy parking and maneuvering when not in use
- Swing-arm model allows rear of vehicle access without removing the carrier
- Keyed locks and weather resistant construction
- Convenient, fully-functioning taillights built in to the carrier; work with or without cargo pod in place



59108

Part No.	Description	Packaging
59108	The Adventure System™, Stationary Non-Tilt, Non-Swing, Fits 1-1/4" Hitches	Display Box
59109	The Adventure System™, Swing-Away, Fits 2" Hitches	Display Box
59110	The Adventure System™, Tilt, Fits 2" Hitches	Display Box
10184	1-1/4" Assembly for Adventure System	Boxed
10186	2" Tilt Up Assembly for Adventure System™	Boxed
10188	The Adventure System™, Includes Tray w/Lights & Pod	Boxed
10421	2" Swing Away Assembly for Adventure System™, 250 lbs. Capacity	Boxed

REPLACEMENT PARTS

Part No.	Description
59117	Adventure System® License Plate Light Kit
59510	Adventure System® Replacement Latch Kit



591109
Swing-Away Version



59110
Tilt Version

THE FLATHEAD™ CARGO CARRIER

- Constructed of feather-light, durable polypropylene and weighing a mere 35 lbs., it's one of the lightest full-size carriers on the market
- 400 lbs. capacity on a 53" x 19" platform: ideal for coolers, bags, or extra gear
- Swing-arm model allows the carrier to be folded upright for easy parking and maneuvering when not in use
- Rise shank design elevates cargo for improved ground clearance
- Convenient 2-piece construction bolts together in minutes



59500

Part No.	Description	Packaging
59500	The FlatHead™ Cargo Carrier, Fits 2" Receiver	Display Box
6504	Incandescent Light Kit	Display Box



1040100

1040200
Optional bi-fold ramp makes loading and unloading wheeled cargo a breeze!

THE SOLO™ CARGO CARRIER

- 400 lbs. capacity on a 48" x 32" platform; ideal for coolers, bags, generators, lawn equipment, or extra gear
- 3" side rails keep cargo secure and in place; includes holes for attaching bungee cords or cargo nets
- Smart, rugged mesh floors make clean-up quick and easy
- Durable powder coat finish resists the elements, scratches, and rust
- Additional accessories available – visit us online for more details
- Fits 2" square receivers
- Ramp length 4' (2' when folded)

Part No.	Description	Packaging
1040100	The Solo™ Cargo Carrier	Display Box
1040200	Ramp for Solo™ Cargo Carrier	Display Box



6502



6504

THE STRONGARM™ CARGO CARRIER

- 500 lbs. capacity on a 48" x 20" platform; ideal for coolers, bags, or anything else that can be loaded up and strapped down
- Swing-arm design allows the carrier to be folded upright for easy parking and maneuvering when not in use
- 3" side rails keep cargo secure and in place
- Powder coat finish resists the elements, scratches, and rust
- Fits 2" receivers
- Light kit #6504 available

Part No.	Description	Packaging
6502	StrongArm™ Folding Cargo Carrier for 2" Sq. Receivers, 20" x 48" Platform	Display Box
6504	Incandescent Light Kit	Display Box



1041500

CARGO TRAY STEEL HITCH MOUNT

- 300 lbs. capacity on a 60" x 20" x 2.5"
- Mesh floor makes clean up quick and easy
- Fits 1.25" or 2". receiver with included adapter

Part No.	Description	Packaging
1041500	Cargo Tray Steel Hitch Mount	Display Box
6504	Incandescent Light Kit	Display Box

1391300



THE BIG SKY™ CARGO CARRIER



- 44" x 35" x 4-1/4" (inside dimensions)
- Rugged construction with water resistant joint covers for years of gear-up-and-go
- Equipped with a custom-fit fairing to improve aerodynamics and reduce wind noise
- Universal mounting hardware accommodates round, square, and factory roof racks
- Powder coat finish resists the elements, scratches, and rust

Part No.	Description	Packaging
1391300	Reese Explorer Cargo Basket	Display Box

59504



THE VORTEX™ CARGO CARRIER

- 48" x 37-1/2" x 5" (inside dimensions)
- Rugged construction; assembles in minutes
- Custom-fit fairing to improve aerodynamics and reduce wind noise
- Universal mounting hardware accommodates round, square, and factory roof racks
- Powder coat finish resists the elements, scratches, and rust
- Weighs only 38 lbs. (including mounting hardware)
- 18-3/4" extension can maximize your rooftop cargo space (sold separately)

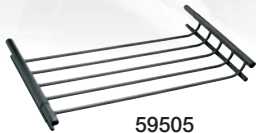

59505

Part No.	Description	Packaging
59504	The Vortex™ Cargo Carrier, Fits 1-1/4" Receivers, 300 lbs. Capacity	Display Box
59505	The Vortex™ Roof Top Cargo Carrier Extension	Display Box

REPLACEMENT PARTS

Part No.	Description
59506	Replacement Part, Hardware Mounting Kit for the Vortex Rooftop Cargo Carrier

63150



THE BULLET BOX™ CARGO CARRIER

- Instantly adds 13 cubic feet of storage to your vehicle (72" x 24" x 17"); holds up to 110 lbs. of gear
- Pebble finish resists scratches and withstands extreme temperatures and weather conditions
- Keyed lock and weather-tight protection
- Substantial 16" opening with stay-open hinges for easy loading and unloading (opens from passenger side)
- Universal mounting system works with most roof racks; fits crossbar spacing from 26-3/4" to 37-1/2"
- Ships pre-assembled

Part No.	Description	Packaging
63150	The Bullet Box™ Cargo Carrier	Display Box



59915

PINHEAD™ HITCH PIN

- M12 threaded anti-rattle pin

Part No.	Description	Packaging
59915	PinHead™ Hitch Pin	Bag w/Label

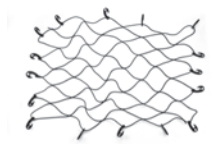

1393700

CARGO NETS

- Ideal for All Roof & Hitch Mounted Cargo Carriers

Part No.	Description	Packaging
1393700	Reese Explorer Cargo Net, 36"x48"	Display Box
59200	Cargo Net, 36" x 48"	Clamshell



59200



RATCHETING CARGO BAR

- Expands from 40" to 70"



Part No.	Description	Packaging
1390600	Ratcheting Cargo Bar 40" to 70"	Display Box



1390600



59516



20174

LIGHT KITS

- Ideal upgrade for The Dart, Vortex, And Rambler Cargo Carriers

Part No.	Description	Packaging
59516	LED Light Kit	Display Box
20174	Incandescent Light Kit	Display Box



6504

LIGHT KIT

- Deal upgrade for the Packer Pro, Axis, and Strong Arm Cargo Carriers
- Includes lighted license plate relocation bracket

Part No.	Description	Packaging
6504	Incandescent Light Kit	Display Box



WALLAROO™ CARGO BAG

- Expands from 9-1/2" to 11-1/2" cubic feet (48" x 19" x 18" to 48" x 19" x 22"); perfect for luggage, camping gear, or anything else you need to bring along for the trip
- Six-strap system keeps the bag firmly in place until you say so
- Weather-resistant construction and sonically sealed seams
- Two interior pockets for smaller items help keep you organized
- Fits hitch-mounted cargo carriers 60" x 24" and up
- Folds up for easy storage when not in use



59102

Part No.	Description	Packaging
59102	Wallaroo™ Cargo Carrier Bag	Display Box

REPLACEMENT PARTS

Part No.	Description
59560	Replacement Part, Strap Kit (6)

THE TUFFBAK™ CARGO BAG

- Adds 20 cubic feet (59" x 24" x 24") outside-the-vehicle storage; perfect for luggage, camping gear, or extra cargo
- Weather-resistant construction, concealed zipper, and sonically sealed seams
- Six-strap system keeps everything in place
- Fits hitch-mounted cargo carriers 60" x 24" and up
- Folds up for easy storage when not in use



59119

Part No.	Description	Packaging
59119	Tuffbak™ Cargo Carrier Bag	Display Box

AMIGO™ CARGO BAG

- Adds 15 cubic feet (59" x 18.5" x 24") of storage space
- Weather-resistant construction and six integrated tie-down straps
- Fits hitch-mounted cargo carriers 59" x 18.5" and up
- Folds up for easy storage when not in use



63604

Part No.	Description	Packaging
63604	Amigo™ Cargo Carrier	Display Box

PLATYPUS® ROOF TOP CARGO BAG

- Adds a maximum 15 cubic feet of cargo space up top
- Expands from 39" x 33" x 14" to 39" x 33" x 18"; from 10 to 15 cubic feet
- Weather-resistant construction
- Cinching system and 8-point strap design keep everything in place



59100

Part No.	Description	Packaging
59100	Platypus® Expandable Roof Top Cargo Bag	Display Box



1041100



RAINPROOF, ROOFTOP CARGO BAG

- Adds 15 cubic feet (38" x 18" x 18") of cargo space
- Constructed with premium quality rainproof material
- Easily attaches to permanent roof racks
- Installation straps included
- Storage bag included

Part No.	Description	Packaging
1041100	Rainproof, Rooftop Cargo Bag	Display Box



1391800

EXPANDABLE, ROOFTOP CARGO BAG

- Expands from 12 to 16 cubic feet for increases cargo space
- Constructed with quality rainproof material
- Attaches to raised side rails and/or permanent cross bars

Part No.	Description	Packaging
1391800	Expandable, Rooftop Cargo Bag	Display Box



59000

M.O.V.E.™ ORGANIZERS

- Removable trunk organizers; ideal for groceries, travel accessories, sports equipment, and more-- brings instant organization to any trunk or cargo space
- Rigid, non-slip base prevents sliding during sudden stops or fast cornering
- Moveable interior dividers, sturdy handles, and exterior mesh pockets add convenience and provide storage options
- Dimensions: 25" or 38" x 15" x 7"
- Folds flat & clips closed for easy storage



59001

Part No.	Description	Packaging
59000	M.O.V.E™ Interior Organizer, 25" x 15" x 7"	Display Box
59001	M.O.V.E™ Interior Organizer, 38" x 15" x 7"	Display Box



1394900

J-RAC™ KAYAK CARRIER

- 165 lbs. load capacity
- Powder coated steel resists rust
- Foam pads cradle and hold your kayak in an upright position
- Hardware works with ROLA and most other crossbars
- Premium heavy-duty straps and bow/stern tie-downs included

Part No.	Description
1394900	J-Rac™ J Style Kayak Carrier

REPLACEMENT PARTS

Part No.	Description
59300	Replacement Part, Boat Tie Down Kit for #59912
59301	Replacement Part, Bottom Mounting Bracket for #59912
59309	Replacement Part, 9' Foot Strap Kit for #59912
59313	Replacement Part, 13' Foot Strap Kit for #59912



59913†



HULL-HAULER™ KAYAK CARRIER

- Multi-pivot rubber saddle system adjusts and conforms to almost any kayak shape and size for a customized, secure fit every time
- Pivoting saddles make loading and unloading watercraft a total breeze
- Powder coated steel resists rust
- Hardware works with ROLA and most other crossbars
- Premium heavy-duty straps and bow/stern tie-downs included

Part No.	Description
59913†	Hull-Hauler™ Universal, Multi-Pivot Water Craft Carrier

REPLACEMENT PARTS

Part No.	Description
59300	Replacement Part, Boat Tie Down Kit for #59913†
59302	Replacement Part, Pivot Knob Assembly for #59913†
59313	Replacement Part, Bottom Mounting Bracket for #59913†
59309	Replacement Part, 9' Foot Strap Kit for #59913†
59313	Replacement Part, 13' Foot Strap Kit for #59913†



59914†

HULL-HUGGER™ GARAGE STORAGE UNIT

- 125 lbs. capacity per set
- Secures directly to any wall of your garage or shed (mounting hardware included)
- Soft foam covers gently “cradle” and protect your kayak during storage
- Smart, swing-arm design folds up and away when not in use
- Perfect for sit-on-tops, singles or tandems
- Powder coat finish to resist water, scratches, and dust; mount inside or out
- Integrated storage hooks keep paddles in their place

Part No.	Description
59914†	Hull-Hugger™ Folding Kayak Rack, Wall Mount Storage

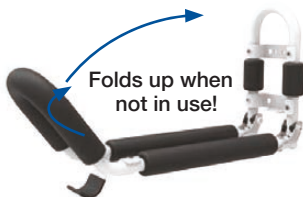

Folds up when not in use!

Integrated Paddle-Grabber



59204

SERVICE & STRAP KITS

Part No.	Description	Packaging
59204	Lashing strap design for luggage or light duty carrying & securing needs	Clamshell

† = Available while supplies last.



TRUCK BED RACK

- Kit includes crossbars w/63" maximum width, locking end caps, 2 sets of upright supports and installation hardware
- Quick & easy no-drill installation
- Rugged, lightweight aluminum construction;
- Powder coated black uprights and stainless steel hardware to resist the elements, scratches, and rust
- Adjustable fore and aft; customizable placement perfect for whatever you need to haul
- Rubber buffer strips protect load from damage
- Anti-theft features for peace of mind; lockable covers and accessory channel
- Compatible with most standard truck beds



Part No.	Description	Packaging
59742	Truck Bed Rack, Removable Rack	Box w/Label

REPLACEMENT PARTS

Part No.	Description
59850	Replacement Part, Truck Bed Rack, M8 T-Bolt

T3 TRUCK BED RACK

- Rugged, lightweight aluminum construction
- Powder coated black uprights and stainless steel hardware to resist the elements, scratches, and rust
- Anti-theft features for peace of mind; locking covers for crossbar accessory channel and locking knobs for slide feature
- Rubber buffer strips protect load from damage
- Kit includes crossbars w/63" maximum width, locking end caps, 2 sets of upright supports and installation hardware
- Designed specifically for the Nissan Titan, Toyota Tundra, and Toyota Tacoma bedrail systems



Part No.	Description	Packaging
59799	T3 Truck Bed Rack, Removable Rack	Box w/Label

REPLACEMENT PARTS

Part No.	Description
59905	Replacement Part, Locking Knob for Truck Rack 59799
59850	Replacement Part, Truck Bed Rack, M8 T-Bolt

V2 & V3 VAN RACK SYSTEMS

- Heavy gauge steel construction; perfect for heavy duty and commercial use
- 2 and 3-bar model options (additional bars available – P/N 59621)
- Fits most vans with rain gutters; telescopic bars adjust from 37" to 62" to create the perfect fit
- Powder coated, hammered finish resists the elements, scratches, and rust
- Load capacity 300 lbs. for the V2 & 450 lbs. for the V3

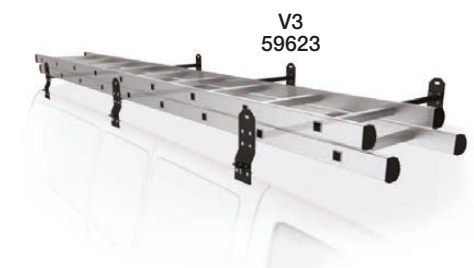

Part No.	Description	Packaging
59621	V1 Universal 1 Bar Van Rack	Box w/Label
59622	V2 Universal 2 Bar Van Rack	Box w/Label
59623	V3 Universal 3 Bar Van Rack	Box w/Label

CONDUIT KIT



- Universal design works with most other truck racks
- Rugged, lightweight powder coated aluminum door and end cap
- Stainless steel U-bolts and hardware
- For use with 6" sch 40 or 80 PVC pipe (not included)
- Door features spring-loaded latch and rubber gasket for increased weather resistance
- Simple, intuitive design for easy, no-drill assembly and installation right out of the box

Part No.	Description
59797	Conduit Kit Truck Bed Rack Accessory, (Requires 6" Diameter PVC Plastic Pipe)

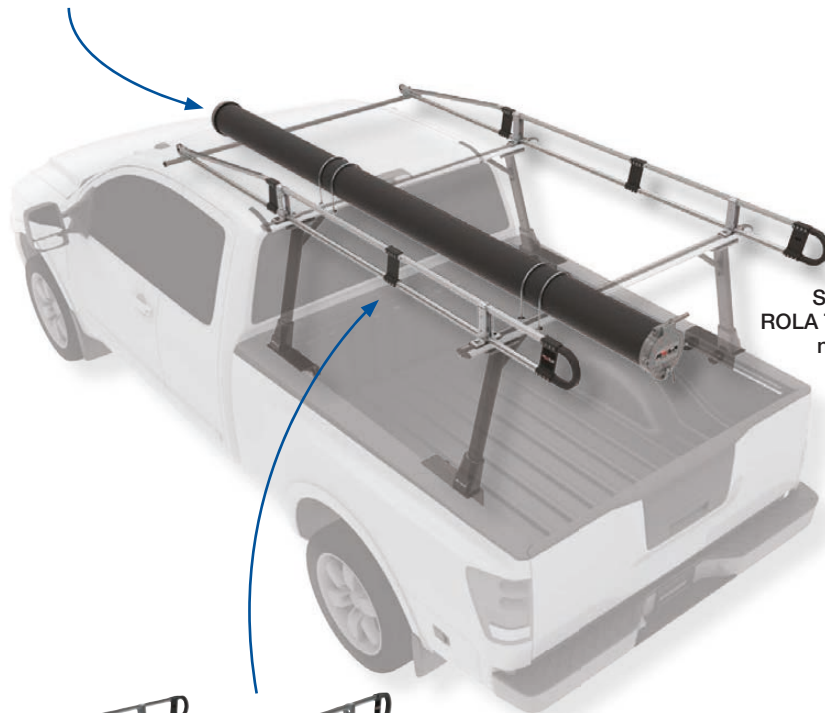

Shown with a ROLA Truck Bed Rack – not included



TOP RAIL KIT

- Universal design works with ROLA and most other truck racks
- Extends your ROLA Truck Rack over your truck's cab for hauling the extra-long stuff without damage to your roof
- Rugged, lightweight anodized aluminum construction
- Powder coat finish and stainless steel hardware to resist the elements and scratches
- Simple, intuitive design for easy, no-drill assembly and installation right out of the box

Part No.	Description
59798	Top Rail Kit Truck Bed Rack Accessory



59794

LOAD STOPS

- Constructed from rugged, lightweight anodized aluminum perfect for lumber, ladders, or anything else you need to load up and secure
- Powder coated to resist the elements
- Universal design; works with most crossbars equipped with accessory T-channel, including ROLA Truck Racks, Roof Racks, and Crossbars
- Durable lock-down knobs and stainless steel hardware included

Part No.	Description	Packaging
59794	Load Stop Kit Truck Bed Rack Accessory	Box w/Label

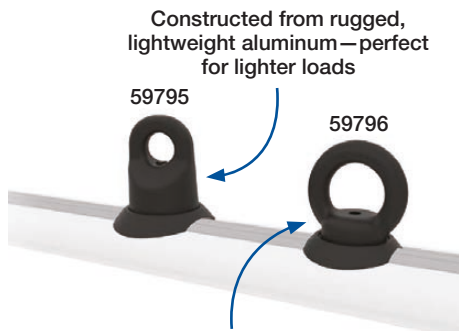

Constructed from rugged, lightweight aluminum—perfect for lighter loads

59795

59796

Constructed from tough-as-nails alloy steel—perfect for tying down the heavy stuff!

TIE-DOWN & EYEBOLT KITS

- Both kits sold as a set of 4
- Powder coated to resist the elements
- Universal design works with ROLA Truck Racks or Crossbars as well as most other crossbars - just slide 'em on and lock 'em down
- Stainless steel hardware included
- Simple, intuitive design for easy installation right out of the box

Part No.	Description
59795	Tie Down Kit Truck Bed Rack Accessory, Aluminum
59796	Tie Down Kit Truck Bed Rack Accessory, Steel



9250900

9251800

9252200

MOVABLE ANCHOR POINT

- Safe and secure tie down attachment with no drilling of truck
- Fits all trucks with or without bedliners
- Corrosion resistant

Part No.	Description
9250900	Anchor Point - Chrome
9251800	Anchor Point - Chrome
9252200	Anchor Point, fits all Chevrolet/GMC Silverado/Sierra, 1994-Current Dodge RAM



TOOL RACK

- Safely holds up to six straight-handle tools; perfect for shovels, rakes, brooms, and more
- Durable powder coated steel resists the elements
- Universal design mounts directly to most truck beds or trailers
- Works with ROLA Top Rail Kit (PN: 59798)
- Rubber grommets protect and hold tools in place during transport

Part No.	Description
59792	Tool Rack Truck Bed Rack Accessory



TRIMMER RACK

- Safely holds up to two full-size trimmers; heavy-duty bail pin closures ensure trimmers stay put during transport
- Durable powder coated steel resists the elements
- Universal design mounts directly to most truck beds or trailers
- Works with ROLA Top Rail Kit (PN: 59798)

Part No.	Description
59793	Truck Bed Rack Accessory, Trimmer Rack Kit

RBU SERIES UNIVERSAL ROOF RACK



Built from super rugged, lightweight aluminum and expertly engineered for optimal aerodynamics to cut down on drag and wind noise.

- Anodized aluminum crossbars, high strength molded nylon and stainless steel hardware ensure these crossbars will be your travel companion for years to come
- Anti-theft locking covers for peace of mind
- Lockable accessory channel for T-bolt applications
- Quick and easy installation and removal
- 5-Year Limited Warranty



Part No.	Crossbar Size	Side Rail Fit Range	Packaging
59897	43-3/8"	33.5-41" / 850 - 1040mm	Boxed
59898	47-1/4"	37.5-44.8" / 950 - 1140mm	Boxed
59899	51-1/8"	41.3-48.8" / 1050 - 1240mm	Boxed
59711	55-1/8"	45.3-52.8" / 1150 - 1340mm	Boxed

CUSTOM ROOF RACK SYSTEMS



REX Series



APE Series



RBXL Series



GTX Series



APX Series



RB Series



AP-GTX Series



TRACK-MOUNT ROOF RACK SYSTEM



Perfect for truck cabs, hard tonneau covers, camper shells, and RVs!

- Track-mount system works with sheet metal or fiberglass surfaces to instantly transform your vehicle into a bike-hauling, kayak-lugging, cargo machine
- Includes two black anodized aluminum tracks, end caps, and hardware
- Works with ROLA APE and APX crossbar systems (sold separately)

Part No.	Description	Packaging
59853	42" Track Rail for Sheet Metal	Boxed
59854	54" Track Rail for Sheet Metal	Boxed
59855	60" Track Rail for Sheet Metal	Boxed

DIRECT/TRACK MOUNT ROOF RACK KITS

Perfect for truck hard tonneau covers, and truck & van roofs!

- Includes universal ROLA® APE crossbars
- Anodized aluminum crossbars, high strength molded nylon, and stainless steel hardware for long life
- Anti-theft locking covers keep crossbar accessories in their place
- Direct mount kits - includes direct mount kit for sheet metal, including two mounting adapters, installation hardware, and covers for when crossbars are removed
- Track mount kits - black anodized aluminum tracks allow crossbar fore and aft adjustability



Direct Mount



Track Mount

Part No.	Description	Packaging
59650	Complete Direct Mounting Kit, (4) Mounting Adapters for Sheet Metal Mounting, & APE Series - Track/Direct Mount, Bar Length 51-1/4" (1300mm)	Boxed
59651	Complete Direct Mounting Kit, (4) Mounting Adapters for Sheet Metal Mounting, & APE Series - Track/Direct Mount, Bar Length 55-1/8" (1400mm)	Boxed
59652	Complete Direct Mounting Kit, (4) Mounting Adapters for Fiberglass Mounting Surface, & APE Series - Track/Direct Mount, Bar Length 51-1/4" (1300mm)	Boxed
59653	Complete Direct Mounting Kit, (4) Mounting Adapters for Fiberglass Mounting Surface, & APE Series - Track/Direct Mount, Bar Length 55-1/8" (1400mm)	Boxed
59654	Complete Direct Mounting Kit, (4) Mounting Adapters for Fiberglass Mounting Surface, & APE Series - Track/Direct Mount, Bar Length 63" (1600mm)	Boxed
59655	Complete Track Rail System, 42" Length (1070mm) for Sheet Metal Mounting Surfaces, & APE Series - Track/Direct Mount, Bar Length 51-1/4" (1300mm)	Boxed
59656	Complete Track Rail System, 42" Length (1070mm) for Sheet Metal Mounting Surfaces, & APE Series - Track/Direct Mount, Bar Length 55-1/8" (1400mm)	Boxed
59657	Complete Track Rail System, 54" Length (1370mm) for Sheet Metal Mounting Surfaces, & APE Series - Track/Direct Mount, Bar Length 51-1/4" (1300mm)	Boxed
59658	Complete Track Rail System, 54" Length (1370mm) for Sheet Metal Mounting Surfaces, & APE Series - Track/Direct Mount, Bar Length 55-1/8" (1400mm)	Boxed
59659	Complete Track Rail System, 60" Length (1520mm) for Fiberglass Mounting Surfaces, & APE Series - Track/Direct Mount, Bar Length 63" (1600mm)	Boxed

DIRECT-MOUNT KITS

- Direct-mount system works with sheet metal or fiberglass surfaces to instantly transform your vehicle into a bike-hauling, kayak-lugging, cargo machine
- Includes mounting adapters, hardware, and covers
- Works with ROLA APE and APX crossbar systems (sold separately)



Part No.	Description	Packaging
59753	Direct-Mount Kit - Fiberglass	Boxed
59754	Direct-Mount Kit - Sheet Metal	Boxed

ROOF RACK APPLICATION GUIDE



MODEL / STYLE	YEAR	PART NO.	FN	MS	WC	IN
ACURA						
MDX w/Factory Roof Rails	07-13	59711	0,LC	RBU	165	15
MDX w/Factory Roof Rails		59899	0	RBU	165	15
RDX w/Factory Roof Rails	11-16	59899	0	RBU	165	15
TSX Sport Wagon, w/Factory Roof Rails	11-14	59898	0	RBU	165	15
AUDI						
A4 Quattro Avant Wagon, w/Factory Roof Rails	98-01	59898	0	RBU	165	15
A4 Quattro Avant Wagon, w/Factory Roof Rails	02-04	59897	0	RBU	165	15
		59898	0,LA	RBU	165	15
A4 Quattro Avant Wagon, w/Factory Roof Rails	05-08	59898	0	RBU	165	15
BMW						
1 Series M	11	59761	0	APE	110	5
118i	12-13	59761	0	APE	110	5
120i	08-12	59761	0	APE	110	5
125i	09-13	59761	0	APE	110	5
128i	08-13	59761	0	APE	110	5
130i	08-10	59761	0	APE	110	5
135i	08-11	59761	0	APE	110	5
135is	13	59761	0	APE	110	5
220i	14-16	59761	0	APE	110	5
220i Active Tourer	16	59761	0	APE	110	5
228i	14-16	59761	0	APE	110	5
228i xDrive	15-16	59761	0	APE	110	5
235i	14	59761	0	APE	110	5
318i	99	59761	0	APE	110	5
		59762	0,LA	APE	110	5
318is	99	59761	0	APE	110	5
		59762	0,LA	APE	110	5
320i	01-05	59761	0	APE	110	5
		59762	0,LA	APE	110	5
320i	12-16	59762	0,LA	APE	110	5
320i xDrive	13-16	59762	0,LA	APE	110	5
323Ci 2 Dr. Coupe	00	59761	0	APE	110	5
		59762	0,LA	APE	110	5
323i	99-00	59761	0	APE	110	5
		59762	0,LA	APE	110	5
323i Sports Wagon w/Factory Roof Rails	00	59898	0	RBU	165	15
323i	06-11	59761	0	APE	110	5
		59762	0,LA	APE	110	5
		59763	0,LB	APE	110	5
323is 2 Dr. Coupe	99	59761	0	APE	110	5
		59762	0,LA	APE	110	5
325Ci 2 Dr. Coupe	01-05	59761	0	APE	110	5
		59762	0,LA	APE	110	5
325Ci 2 Dr. Coupe	06	59761	0	APE	110	5
		59762	0,LA	APE	110	5
		59763	0,LB	APE	110	5
325i	01-05	59762	0,LA	APE	110	5
325i	01-13	59761	0	APE	110	5
325i Sports Wagon w/Factory Roof Rails	01-05	59898	0	RBU	165	15
325i	06	59763	0,LB	APE	110	5
325i	06-13	59762	0,LA	APE	110	5
325xi	01-05	59762	0,LA	APE	110	5
325xi 4 Dr. Sedan	01-05	59761	0	APE	110	5
325xi Sports Wagon w/Factory Roof Rails	01-05	59898	0	RBU	165	15
325xi 4 Dr. Sedan	06	59761	0	APE	110	5
		59762	0,LA	APE	110	5
		59763	0,LB	APE	110	5
328Ci 2 Dr. Coupe	00	59761	0	APE	110	5
		59762	0,LA	APE	110	5
328d	14-16	59762	0,LA	APE	110	5
328d xDrive	14-16	59762	0,LA	APE	110	5
328i	99-00	59761	0	APE	110	5
		59762	0,LA	APE	110	5

MODEL / STYLE	YEAR	PART NO.	FN	MS	WC	IN
BMW (Continued)						
328i	07-14	59761	0	APE	110	5
		59763	0,LB	APE	110	5
328i	07-15	59762	0,LA	APE	110	5
328i Sports Wagon w/Factory Roof Rails	07-12	59898	0	RBU	165	15
328i GT xDrive	14-15	59762	0,LA	APE	110	5
328i xDrive	09-16	59761	0	APE	110	5
		59762	0,LA	APE	110	5
		59763	0,LB	APE	110	5
328is	99	59761	0	APE	110	5
		59762	0,LA	APE	110	5
328xi	07-08	59761	0	APE	110	5
		59762	0,LA	APE	110	5
		59763	0,LB	APE	110	5
328xi Sports Wagon w/Factory Roof Rails	07-08	59898	0	RBU	165	15
330Ci 2 Dr. Coupe	01-05	59761	0	APE	110	5
		59762	0,LA	APE	110	5
330Ci 2 Dr. Coupe	06	59761	0	APE	110	5
		59762	0,LA	APE	110	5
		59763	0,LB	APE	110	5
330i	01-05	59761	0	APE	110	5
		59762	0,LA	APE	110	5
330i	06	59761	0	APE	110	5
		59763	0,LB	APE	110	5
330i	06-07	59762	0,LA	APE	110	5
330i	16	59762	0,LA	APE	110	5
330xi 4 Dr. Sedan	01-05	59761	0	APE	110	5
		59762	0,LA	APE	110	5
330xi	06	59761	0	APE	110	5
		59762	0,LA	APE	110	5
		59763	0,LB	APE	110	5
335d 4 Dr. Sedan	09-11	59761	0	APE	110	5
		59762	0,LA	APE	110	5
		59763	0,LB	APE	110	5
335i	07-13	59761	0	APE	110	5
		59763	0,LB	APE	110	5
335i	07-15	59762	0,LA	APE	110	5
335i	14-16	59761	0	APE	110	5
335i GT xDrive	14-15	59762	0,LA	APE	110	5
335i xDrive	09-11	59762	0,LA	APE	110	5
335i xDrive	09-13	59761	0	APE	110	5
		59763	0,LB	APE	110	5
335i xDrive	13-15	59762	0,LA	APE	110	5
335i xDrive	14-16	59761	0	APE	110	5
335is 2 Dr. Coupe	11-13	59761	0	APE	110	5
		59762	0,LA	APE	110	5
		59763	0,LB	APE	110	5
335xi	07-08	59761	0	APE	110	5
		59763	0,LB	APE	110	5
335xi	07-10	59762	0,LA	APE	110	5
340i	16	59762	0,LA	APE	110	5
340i xDrive	16	59762	0,LA	APE	110	5
420i	16	59761	0	APE	110	5
428i	14-15	59761	0	APE	110	5
428i xDrive	14-16	59761	0	APE	110	5
435i	14-15	59761	0	APE	110	5
435i xDrive	14-16	59761	0	APE	110	5
520i	14-16	59762	0	APE	110	5
525i	01-03	59762	0	APE	110	5
525i 4 Dr. Sedan	01-03	59763	0,LB	APE	110	5
525i Sports Wagon w/Factory Roof Rails	01-03	59898	0	RBU	165	15
528i	97-00	59762	0	APE	110	5
528i 4 Dr. Sedan	97-00	59763	0,LB	APE	110	5
528i Sports Wagon w/Factory Roof Rails	00	59898	0	RBU	165	15
528i	11-16	59762	0	APE	110	5
528i xDrive	12-16	59762	0	APE	110	5

ROOF RACK APPLICATION GUIDE (CONTINUED)



MODEL / STYLE	YEAR	PART NO.	FN	MS	WC	IN
BMW (Continued)						
530i	01-03	59762	0	APE	110	5
530i 4 Dr. Sedan	01-03	59763	0, LB	APE	110	5
530i	12-13	59762	0	APE	110	5
530xi Sports Wagon w/Factory Roof Rails	06-07	59898	0	RBU	165	15
535d	14-16	59762	0	APE	110	5
535d xDrive	14-16	59762	0	APE	110	5
535i	11-16	59762	0	APE	110	5
535i xDrive	11-16	59762	0	APE	110	5
535xi Sports Wagon w/Factory Roof Rails	08	59898	0	RBU	165	15
540i	97-03	59762	0	APE	110	5
540i 4 Dr. Sedan	97-03	59763	0, LB	APE	110	5
540i Sports Wagon w/Factory Roof Rails	99-03	59898	0	RBU	165	15
550i	11-16	59762	0	APE	110	5
550i xDrive	11-16	59762	0	APE	110	5
M3 2 Dr. Coupe	01-06	59761	0	APE	110	5
		59762	0, LA	APE	110	5
M3 2 Dr. Coupe	08-13	59761	0	APE	110	5
		59762	0, LA	APE	110	5
		59763	0, LB	APE	110	5
M5 4 Dr. Sedan	00-03	59762	0	APE	110	5
		59763	0, LB	APE	110	5
X3 w/Factory Roof Rails	04-10	59827	0	RB	110	15
		59899	0	RBU	165	15
X5 w/Factory Roof Rails	00-06	59828	0	RB	110	15
		59899	0	RBU	165	15
X5 w/Factory Roof Rails	07-10	59829	0	RB	110	15
		59899	0	RBU	165	15
BUICK						
Rainier w/Factory Roof Rails	06-07	59898	0	RBU	165	15
CADILLAC						
Escalade w/Factory Roof Rails	15-16	59685	0	REX	165	15
Escalade ESV w/Factory Roof Rails	15-16	59685	0	REX	165	15
SRX w/Factory Roof Rails	04-09	59898	0	RBU	165	15
		59899	0, LB	RBU	165	15
SRX w/Factory Roof Rails	10-13	59899	0, LB	RBU	165	15
SRX w/Factory Roof Rails	10-16	59893	0	RBXL	165	5
		59898	0	RBU	165	15
CHEVROLET						
Avalanche w/Factory Roof Rails	07-13	59711	0, LC	RBU	165	15
		59899	0	RBU	165	15
Blazer Downsize, w/Factory Roof Rails	95-97	59898	0	RBU	165	15
Blazer Downsize, w/Factory Roof Rails	03-04	59898	0	RBU	165	15
Blazer Trailblazer w/Factory Roof Rails	99-01	59898	0	RBU	165	15
Captiva Sport w/Factory Roof Rails	08-15	59898	0	RBU	165	15
Colorado	04-12	59754	UG, UJ	DMS	165	45
		59853	UG, UJ	TRS	165	60
		59742	0, UJ	TBR	400	40
Colorado w/Aftermarket Fiberglass Flat Roof Cap or Tonneau	04-12	59753	UH, UJ	DMS	165	30
		59855	UH, UJ	TRS	165	40
Colorado	14-16	59754	UG, UJ	DMS	165	45
		59853	UG, UJ	TRS	165	60
		59742	0, UJ	TBR	400	40
Colorado w/Aftermarket Fiberglass Flat Roof Cap or Tonneau	14-16	59753	UH, UJ	DMS	165	30
		59855	UH, UJ	TRS	165	40
Equinox w/Factory Roof Rails	10-17	59786	0	REX	165	15
Express 1500	96-14	59754	UG, UJ	DMS	165	45
		59853	UG, UJ	TRS	165	60
		59854	UG, UJ	TRS	165	60
Express 2500	96-17	59754	UG, UJ	DMS	165	45
		59853	UG, UJ	TRS	165	60
		59854	UG, UJ	TRS	165	60
Express 3500	96-17	59754	UG, UJ	DMS	165	45
		59853	UG, UJ	TRS	165	60
		59854	UG, UJ	TRS	165	60

MODEL / STYLE	YEAR	PART NO.	FN	MS	WC	IN
CHEVROLET (Continued)						
G10	75-95	59754	UG, UJ	DMS	165	45
		59853	UG, UJ	TRS	165	60
		59854	UG, UJ	TRS	165	60
G10 Van	71-74	59754	UG, UJ	DMS	165	45
		59853	UG, UJ	TRS	165	60
		59854	UG, UJ	TRS	165	60
G20	75-95	59754	UG, UJ	DMS	165	45
		59853	UG, UJ	TRS	165	60
		59854	UG, UJ	TRS	165	60
G20 Van	71-74	59754	UG, UJ	DMS	165	45
		59853	UG, UJ	TRS	165	60
		59854	UG, UJ	TRS	165	60
G30	75-96	59754	UG, UJ	DMS	165	45
		59853	UG, UJ	TRS	165	60
		59854	UG, UJ	TRS	165	60
G30 Van	71-74	59754	UG, UJ	DMS	165	45
		59853	UG, UJ	TRS	165	60
		59854	UG, UJ	TRS	165	60
HHR w/Factory Roof Rails	06-11	59897	0	RBU	165	15
HHR SS w/Factory Roof Rails	08-10	59897	0	RBU	165	15
S10	94-04	59754	UG, UJ	DMS	165	45
		59853	UG, UJ	TRS	165	60
		59742	0, UJ	TBR	400	40
S10 w/Aftermarket Fiberglass Flat Roof Cap or Tonneau	94-04	59753	UH, UJ	DMS	165	30
		59855	UH, UJ	TRS	165	40
Silverado 1500 (Classic)	99-07	59754	UG, UJ	DMS	165	45
		59853	UG, UJ	TRS	165	60
		59742	0, UJ	TBR	400	40
Silverado 1500 (Classic), w/Aftermarket Fiberglass Flat Roof Cap or Tonneau	99-07	59753	UH, UJ	DMS	165	30
		59855	UH, UJ	TRS	165	40
Silverado 1500	07-17	59754	UG, UJ	DMS	165	45
		59853	UG, UJ	TRS	165	60
		59742	0, UJ	TBR	400	40
Silverado 1500 w/Aftermarket Fiberglass Flat Roof Cap or Tonneau	07-17	59753	UH, UJ	DMS	165	30
		59855	UH, UJ	TRS	165	40
Silverado 1500 HD (Classic)	01-07	59754	UG, UJ	DMS	165	45
		59853	UG, UJ	TRS	165	60
		59742	0, UJ	TBR	400	40
Silverado 1500 HD (Classic), w/Aftermarket Fiberglass Flat Roof Cap or Tonneau	01-07	59753	UH, UJ	DMS	165	30
		59855	UH, UJ	TRS	165	40
Silverado 2500	99-04	59754	UG, UJ	DMS	165	45
		59853	UG, UJ	TRS	165	60
		59742	0, UJ	TBR	400	40
Silverado 2500 w/Aftermarket Fiberglass Flat Roof Cap or Tonneau	99-04	59753	UH, UJ	DMS	165	30
		59855	UH, UJ	TRS	165	40
Silverado 2500 HD (Classic)	01-07	59754	UG, UJ	DMS	165	45
		59853	UG, UJ	TRS	165	60
		59742	0, UJ	TBR	400	40
Silverado 2500 HD (Classic), w/Aftermarket Fiberglass Flat Roof Cap or Tonneau	01-07	59753	UH, UJ	DMS	165	30
		59855	UH, UJ	TRS	165	40
Silverado 2500 HD	07-16	59754	UG, UJ	DMS	165	45
		59853	UG, UJ	TRS	165	60
		59742	0, UJ	TBR	400	40
Silverado 2500 HD w/Aftermarket Fiberglass Flat Roof Cap or Tonneau	07-16	59753	UH, UJ	DMS	165	30
		59855	UH, UJ	TRS	165	40
Silverado 3500 (Classic)	01-07	59754	UG, UJ	DMS	165	45
		59853	UG, UJ	TRS	165	60
		59742	0, UJ	TBR	400	40
Silverado 3500 (Classic), w/Aftermarket Fiberglass Flat Roof Cap or Tonneau	01-07	59753	UH, UJ	DMS	165	30
		59855	UH, UJ	TRS	165	40
Silverado 3500 HD	07-16	59754	UG, UJ	DMS	165	45
		59853	UG, UJ	TRS	165	60
		59742	0, UJ	TBR	400	40

ROOF RACK APPLICATION GUIDE (CONTINUED)



MODEL / STYLE	YEAR	PART NO.	FN	MS	WC	IN
CHEVROLET (Continued)						
Silverado 3500 HD w/Aftermarket Fiberglass Flat Roof Cap or Tonneau	07-16	59753	UH,UJ	DMS	165	30
		59855	UH,UJ	TRS	165	40
Spark w/Factory Roof Rails	13-16	59897	Ø	RBU	165	15
Suburban w/Factory Roof Rails	15-16	59685	Ø	REX	165	15
Suburban 1500 w/Factory Roof Rails	00-14	59711	Ø,LC	RBU	165	15
		59899	Ø	RBU	165	15
Suburban C1500 w/Factory Roof Rails	92-99	59711	Ø,LC	RBU	165	15
		59899	Ø	RBU	165	15
Suburban C2500 w/Factory Roof Rails	92-99	59711	Ø,LC	RBU	165	15
		59899	Ø	RBU	165	15
Suburban K1500 w/Factory Roof Rails	92-99	59711	Ø,LC	RBU	165	15
		59899	Ø	RBU	165	15
Suburban K2500 w/Factory Roof Rails	92-99	59711	Ø,LC	RBU	165	15
		59899	Ø	RBU	165	15
Tahoe w/Factory Roof Rails	95-00	59711	Ø,LC	RBU	165	15
		59899	Ø	RBU	165	15
Tahoe w/Factory Roof Rails	00-14	59711	Ø,LC	RBU	165	15
		59899	Ø	RBU	165	15
Tahoe w/Factory Roof Rails	15-16	59685	Ø	REX	165	15
Tracker w/Factory Roof Rails	98-04	59899	Ø	RBU	165	15
Trax w/Factory Roof Rails	13-16	59898	Ø	RBU	165	15
Uplander w/Factory Roof Rails	05-08	59899	Ø	RBU	165	15
Uplander w/Factory Roof Rails (Canada Only)	09	59899	Ø	RBU	165	15
Venture w/Factory Roof Rails	97-05	59898	Ø	RBU	165	15
		59899	Ø,LB	RBU	165	15
CHRYSLER						
Aspen w/Factory Roof Rails	07-09	59898	Ø	RBU	165	15
		59899	Ø,LB	RBU	165	15
DODGE						
Dakota	97-10	59754	UG,UJ	DMS	165	45
		59853	UG,UJ	TRS	165	60
		59742	Ø,UJ	TBR	400	40
Dakota w/Aftermarket Fiberglass Flat Roof Cap or Tonneau	97-10	59753	UH,UJ	DMS	165	30
		59855	UH,UJ	TRS	165	40
Durango w/Factory Roof Rails	04-09	59898	Ø	RBU	165	15
		59899	Ø,LB	RBU	165	15
Journey w/Factory Raised Roof Rails	09-15	59898	Ø	RBU	165	15
		59899	Ø,LB	RBU	165	15
Ram 1500	94-01	59754	UG,UJ	DMS	165	45
		59853	UG,UJ	TRS	165	60
		59742	Ø,UJ	TBR	400	40
Ram 1500 w/Aftermarket Fiberglass Flat Roof Cap or Tonneau	94-01	59753	UH,UJ	DMS	165	30
		59855	UH,UJ	TRS	165	40
Ram 1500	02-08	59754	UG,UJ	DMS	165	45
		59853	UG,UJ	TRS	165	60
		59742	Ø,UJ	TBR	400	40
Ram 1500 w/Aftermarket Fiberglass Flat Roof Cap or Tonneau	02-08	59753	UH,UJ	DMS	165	30
		59855	UH,UJ	TRS	165	40
Ram 1500	09-10	59754	UG,UJ	DMS	165	45
		59853	UG,UJ	TRS	165	60
		59742	Ø,UJ	TBR	400	40
Ram 1500 w/Aftermarket Fiberglass Flat Roof Cap or Tonneau	09-10	59753	UH,UJ	DMS	165	30
		59855	UH,UJ	TRS	165	40
Ram 2500	94-02	59754	UG,UJ	DMS	165	45
		59853	UG,UJ	TRS	165	60
		59742	Ø,UJ	TBR	400	40
Ram 2500 w/Aftermarket Fiberglass Flat Roof Cap or Tonneau	94-02	59753	UH,UJ	DMS	165	30
		59855	UH,UJ	TRS	165	40
Ram 2500	03-09	59754	UG,UJ	DMS	165	45
		59853	UG,UJ	TRS	165	60
		59742	Ø,UJ	TBR	400	40
Ram 2500 w/Aftermarket Fiberglass Flat Roof Cap or Tonneau	03-09	59753	UH,UJ	DMS	165	30
		59855	UH,UJ	TRS	165	40

MODEL / STYLE	YEAR	PART NO.	FN	MS	WC	IN
DODGE (Continued)						
Ram 2500	10	59754	UG,UJ	DMS	165	45
		59853	UG,UJ	TRS	165	60
		59742	Ø,UJ	TBR	400	40
Ram 2500 w/Aftermarket Fiberglass Flat Roof Cap or Tonneau	10	59753	UH,UJ	DMS	165	30
		59855	UH,UJ	TRS	165	40
Ram 3500	94-02	59754	UG,UJ	DMS	165	45
		59853	UG,UJ	TRS	165	60
		59742	Ø,UJ	TBR	400	40
Ram 3500 w/Aftermarket Fiberglass Flat Roof Cap or Tonneau	94-02	59753	UH,UJ	DMS	165	30
		59855	UH,UJ	TRS	165	40
Ram 3500	03-09	59754	UG,UJ	DMS	165	45
		59853	UG,UJ	TRS	165	60
		59742	Ø,UJ	TBR	400	40
Ram 3500 w/Aftermarket Fiberglass Flat Roof Cap or Tonneau	03-09	59753	UH,UJ	DMS	165	30
		59855	UH,UJ	TRS	165	40
Ram 3500	10	59754	UG,UJ	DMS	165	45
		59853	UG,UJ	TRS	165	60
		59742	Ø,UJ	TBR	400	40
Ram 3500 w/Aftermarket Fiberglass Flat Roof Cap or Tonneau	10	59753	UH,UJ	DMS	165	30
		59855	UH,UJ	TRS	165	40
FORD						
E-100 Econoline	75-83	59754	UG,UJ	DMS	165	45
		59853	UG,UJ	TRS	165	60
		59854	UG,UJ	TRS	165	60
E-150 Econoline	75-14	59754	UG,UJ	DMS	165	45
		59853	UG,UJ	TRS	165	60
		59854	UG,UJ	TRS	165	60
E-250 Econoline	75-14	59754	UG,UJ	DMS	165	45
		59853	UG,UJ	TRS	165	60
		59854	UG,UJ	TRS	165	60
E-350 Econoline	75-02	59754	UG,UJ	DMS	165	45
		59853	UG,UJ	TRS	165	60
		59854	UG,UJ	TRS	165	60
E-350 Econoline Super Duty	03-14	59754	UG,UJ	DMS	165	45
		59853	UG,UJ	TRS	165	60
		59854	UG,UJ	TRS	165	60
Edge Except w/Factory Roof Rails	07-14	59770	Ø	GTX	110	5
Edge w/Factory Roof Rails	07-14	59899	Ø	RBU	165	15
Escape w/Factory Roof Rails	08-12	59897	Ø	RBU	165	15
		59898	Ø,LA	RBU	165	15
Escape w/Factory Roof Rails	13-16	59898	Ø	RBU	165	15
		59899	Ø,LB	RBU	165	15
Explorer 2 Dr. Sport, w/Factory Roof Rails	01-03	59899	Ø	RBU	165	15
Explorer 4 Dr., w/Factory Roof Rails	02-05	59897	Ø	RBU	165	15
		59898	Ø,LA	RBU	165	15
Explorer w/Factory Roof Rails	11-15	59711	Ø	RBU	165	15
Explorer Sport Trac w/Factory Roof Rails	01-05	59899	Ø	RBU	165	15
F-150	04-17	59754	UG,UJ	DMS	165	45
		59853	UG,UJ	TRS	165	60
F-150 Except Flareside	04-17	59742	Ø,UJ	TBR	400	40
F-150 w/Aftermarket Fiberglass Flat Roof Cap or Tonneau	04-17	59753	UH,UJ	DMS	165	30
		59855	UH,UJ	TRS	165	40
Fiesta 4 Dr. Sedan	11-16	59769	Ø	GTX	110	5
Fiesta 5 Dr. Hatchback	11-16	59768	Ø	GTX	110	5
Freestar w/Factory Roof Rails	04-07	59897	Ø	RBU	165	15
		59898	Ø,LA	RBU	165	15
Freestyle w/Factory Roof Rails	05-07	59899	Ø	RBU	165	15
Ranger	01-11	59754	UG,UJ	DMS	165	45
		59853	UG,UJ	TRS	165	60
		59742	Ø,UJ	TBR	400	40
Ranger w/Aftermarket Fiberglass Flat Roof Cap or Tonneau	01-11	59753	UH,UJ	DMS	165	30
		59855	UH,UJ	TRS	165	40

ROOF RACK APPLICATION GUIDE (CONTINUED)



MODEL / STYLE	YEAR	PART NO.	FN	MS	WC	IN
FORD (Continued)						
Transit Connect	10-16	59754	UG,UJ	DMS	165	45
		59853	UG,UJ	TRS	165	60
		59854	UG,UJ	TRS	165	60
Transit Connect Except w/Factory Roof Rails, With Roof Anchor Points	10-13	59968	Ø	APE	165	15
Transit-150	14-17	59853	UG,UJ	TRS	165	60
Transit-250	14-17	59853	UG,UJ	TRS	165	60
Transit-350	14-17	59853	UG,UJ	TRS	165	60
GMC						
Acadia w/Factory Roof Rails	10-16	59680		REX	165	15
Canyon	04-12	59754	UG,UJ	DMS	165	45
		59853	UG,UJ	TRS	165	60
		59742	Ø,UJ	TBR	400	40
Canyon w/Aftermarket Fiberglass Flat Roof Cap or Tonneau	04-12	59753	UH,UJ	DMS	165	30
G15	75-78	59754	UG,UJ	DMS	165	45
		59853	UG,UJ	TRS	165	60
		59854	UG,UJ	TRS	165	60
G15/G1500 Van	71-74	59754	UG,UJ	DMS	165	45
		59853	UG,UJ	TRS	165	60
		59854	UG,UJ	TRS	165	60
G1500	79-95	59754	UG,UJ	DMS	165	45
		59853	UG,UJ	TRS	165	60
		59854	UG,UJ	TRS	165	60
G25	75-78	59754	UG,UJ	DMS	165	45
		59853	UG,UJ	TRS	165	60
		59854	UG,UJ	TRS	165	60
G25/G2500 Van	71-74	59754	UG,UJ	DMS	165	45
		59853	UG,UJ	TRS	165	60
		59854	UG,UJ	TRS	165	60
G2500	79-95	59754	UG,UJ	DMS	165	45
		59853	UG,UJ	TRS	165	60
		59854	UG,UJ	TRS	165	60
G35	75-78	59754	UG,UJ	DMS	165	45
		59853	UG,UJ	TRS	165	60
		59854	UG,UJ	TRS	165	60
G35/G3500 Van	71-74	59754	UG,UJ	DMS	165	45
		59853	UG,UJ	TRS	165	60
		59854	UG,UJ	TRS	165	60
G3500	79-96	59754	UG,UJ	DMS	165	45
		59853	UG,UJ	TRS	165	60
		59854	UG,UJ	TRS	165	60
Jimmy Downsize, w/Factory Roof Rails	02	59898	Ø	RBU	165	15
Savana 1500	96-14	59754	UG,UJ	DMS	165	45
		59853	UG,UJ	TRS	165	60
		59854	UG,UJ	TRS	165	60
Savana 2500	96-17	59754	UG,UJ	DMS	165	45
		59853	UG,UJ	TRS	165	60
		59854	UG,UJ	TRS	165	60
Savana 3500	96-17	59754	UG,UJ	DMS	165	45
		59853	UG,UJ	TRS	165	60
		59854	UG,UJ	TRS	165	60
Sierra 1500 (Classic)	99-07	59754	UG,UJ	DMS	165	45
		59853	UG,UJ	TRS	165	60
		59742	Ø,UJ	TBR	400	40
Sierra 1500 (Classic), w/Aftermarket Fiberglass Flat Roof Cap or Tonneau	99-07	59753	UH,UJ	DMS	165	30
Sierra 1500	07-17	59754	UG,UJ	DMS	165	45
		59853	UG,UJ	TRS	165	60
		59742	Ø,UJ	TBR	400	40
Sierra 1500 w/Aftermarket Fiberglass Flat Roof Cap or Tonneau	07-17	59753	UH,UJ	DMS	165	30
Sierra 1500 HD (Classic)	01-07	59754	UG,UJ	DMS	165	45
		59853	UG,UJ	TRS	165	60
		59742	Ø,UJ	TBR	400	40

MODEL / STYLE	YEAR	PART NO.	FN	MS	WC	IN
GMC (Continued)						
Sierra 1500 HD (Classic), w/Aftermarket Fiberglass Flat Roof Cap or Tonneau	01-07	59753	UH,UJ	DMS	165	30
		59855	UH,UJ	TRS	165	40
		59754	UG,UJ	DMS	165	45
Sierra 2500	99-04	59853	UG,UJ	TRS	165	60
		59742	Ø,UJ	TBR	400	40
		59753	UH,UJ	DMS	165	30
Sierra 2500 w/Aftermarket Fiberglass Flat Roof Cap or Tonneau	99-04	59855	UH,UJ	TRS	165	40
Sierra 2500 HD (Classic)	01-07	59754	UG,UJ	DMS	165	45
		59853	UG,UJ	TRS	165	60
		59742	Ø,UJ	TBR	400	40
Sierra 2500 HD (Classic), w/Aftermarket Fiberglass Flat Roof Cap or Tonneau	01-07	59753	UH,UJ	DMS	165	30
Sierra 2500 HD	07-16	59754	UG,UJ	DMS	165	45
		59853	UG,UJ	TRS	165	60
		59742	Ø,UJ	TBR	400	40
Sierra 2500 HD w/Aftermarket Fiberglass Flat Roof Cap or Tonneau	07-16	59753	UH,UJ	DMS	165	30
Sierra 3500 (Classic)	01-07	59754	UG,UJ	DMS	165	45
		59853	UG,UJ	TRS	165	60
		59742	Ø,UJ	TBR	400	40
Sierra 3500 (Classic), w/Aftermarket Fiberglass Flat Roof Cap or Tonneau	01-07	59753	UH,UJ	DMS	165	30
Sierra 3500 HD	07-16	59754	UG,UJ	DMS	165	45
		59853	UG,UJ	TRS	165	60
		59742	Ø,UJ	TBR	400	40
Sierra 3500 HD w/Aftermarket Fiberglass Flat Roof Cap or Tonneau	07-16	59753	UH,UJ	DMS	165	30
Sonoma	94-04	59754	UG,UJ	DMS	165	45
		59853	UG,UJ	TRS	165	60
		59742	Ø,UJ	TBR	400	40
Sonoma w/Aftermarket Fiberglass Flat Roof Cap or Tonneau	94-04	59753	UH,UJ	DMS	165	30
Terrain w/Factory Roof Rails	10-17	59786	Ø	REX	165	15
Yukon w/Factory Roof Rails	92-00	59711	Ø,LC	RBU	165	15
		59899	Ø	RBU	165	15
Yukon w/Amber Turn Signals	00-14	59711	Ø,LC	RBU	165	15
		59899	Ø	RBU	165	15
Yukon w/Factory Roof Rails	15-16	59685	Ø	REX	165	15
Yukon XL w/Factory Roof Rails	15-16	59685	Ø	REX	165	15
Yukon XL 1500 w/Factory Roof Rails	00-14	59711	Ø,LC	RBU	165	15
		59899	Ø	RBU	165	15
Yukon XL 2500 w/Factory Roof Rails	00-13	59711	Ø,LC	RBU	165	15
		59899	Ø	RBU	165	15
HONDA						
Accord Sedan	08-12	59757	Ø	GTX	110	5
Civic 4 Dr. Sedan	06-11	59759	Ø	GTX	110	5
Civic 4 Dr. Sedan	12-15	59758	Ø	GTX	110	5
CR-V w/Factory Roof Rails	12-16	59681	Ø	REX	165	20
Fit	07-08	59755	Ø	GTX	110	5
Fit	09-13	59756	Ø	GTX	110	5
Odyssey w/Factory Roof Rails	99-13	59898	Ø	RBU	165	15
		59899	Ø,LB	RBU	165	15
Passport w/Factory Roof Rails	98-02	59711	Ø,LC	RBU	165	15
		59899	Ø	RBU	165	15
Pilot w/Factory Roof Rails	03-08	59898	Ø	RBU	165	15
		59899	Ø,LB	RBU	165	15
Pilot Except w/Factory Roof Rails	09-15	59760	Ø	GTX	110	15
Pilot w/Factory Roof Rails	09-13	59899	Ø	RBU	165	15
Pilot w/Factory Roof Rails	09-15	59711	Ø,LC	RBU	165	15
HYUNDAI						
Accent 4 Dr. Sedan, Except w/Factory Roof Rails	12-16	59884	Ø	GTX	110	15
Accent 5 Dr. Hatchback, Except w/Factory Roof Rails	12-14	59707	Ø	APX	100	5
		59715	Ø,LB	APE	110	5

ROOF RACK APPLICATION GUIDE (CONTINUED)



MODEL / STYLE	YEAR	PART NO.	FN	MS	WC	IN
HYUNDAI (Continued)						
Accent 5 Dr. Hatchback, Except w/Factory Roof Rails	12-16	59713 59714	0 0.LA	APE APE	110 110	5 5
Elantra Wagon, w/Factory Roof Rails	96-00	59897 59898	0 0.LA	RBU RBU	165 165	15 15
Elantra 4 Dr. Sedan	07-10	59803†	0	RM	110	15
Elantra Touring 5 Dr., Except w/Factory Roof Rails	09-12	59800†	0	GTX	110	15
Elantra Touring 5 Dr., w/Factory Roof Rails	09-12	59897 59898	0 0.LA	RBU RBU	165 165	15 15
Elantra 4 Dr. Sedan, Except w/Factory Roof Rails	11-16	59867	0	GTX	110	15
Elantra 2 Dr. Coupe, Except w/Factory Roof Rails	13-16	59741	0	GTX	110	5
Elantra GT Except w/Factory Roof Rails	13-16	59740	0.LE	GTX	110	5
Santa Fe w/Factory Roof Rails	01-06	59898 59899	0 0.LB	RBU RBU	165 165	15 15
Santa Fe Except w/Factory Roof Rails, (6/7 Passenger)	13-17	59779	0	GTX	110	15
Santa Fe Sport w/Factory Roof Rails, (5 Passenger)	13-17	59766	0	REX	110	5
Santa Fe Sport, Except w/Factory Roof Rails, (5 Passenger)	13-14	59779	0	GTX	110	15
Santa Fe w/Factory Roof Rails, (6/7 Passenger)	13-17	59766	0	REX	110	5
Sonata Except w/Factory Roof Rails	11-14	59866	0	GTX	110	15
Tucson w/Factory Roof Rails	05-09	59898 59899	0 0.LB	RBU RBU	165 165	15 15
Tucson GL (US Only)	10-15	59730	0	GTX	110	5
Tucson w/Factory Roof Rails	10-15	59870 59898 59899	0 0 0.LB	RBXL RBU RBU	165 165 165	15 15 15
Veloster Except w/Factory Roof Rails	12-16	59726	0.LE	GTX	110	5
Veracruz w/Factory Roof Rails	07-12	59898 59899	0 0.LB	RBU RBU	165 165	15 15
INFINITI						
EX35 w/Factory Roof Rails	08-12	59897	0	RBU	165	15
FX35 w/Factory Roof Rails	03-12	59898	0	RBU	165	15
FX45 w/Factory Roof Rails	03-08	59898	0	RBU	165	15
FX50 w/Factory Roof Rails	09-13	59898	0	RBU	165	15
QX50 w/Factory Roof Rails	14-16	59898	0	RBU	165	15
QX56 w/Factory Roof Rails	11-13	59711	0	RBU	165	15
QX60 w/Factory Roof Rails	14-17	59898	0	RBU	165	15
QX70 w/Factory Roof Rails	14-16	59898	0	RBU	165	15
QX80 w/Factory Roof Rails	14-16	59711	0	RBU	165	15
ISUZU						
Rodeo w/Factory Roof Rails	98-04	59711 59899	0.LC 0	RBU RBU	165 165	15 15
JEEP						
Cherokee w/Factory Roof Rails	14-17	59682	0	REX	165	10
Grand Cherokee w/Factory Roof Rails	99-04	59898	0	RBU	165	15
Grand Cherokee w/Factory Roof Rails	05-10	59899	0	RBU	165	15
Grand Cherokee	11-17	59966 59967	0.LB 0	APE GTX	165 165	10 10
Liberty w/Factory Roof Rails	02-07	59898 59899	0 0.LB	RBU RBU	165 165	15 15
Liberty w/Factory Roof Rails	08-12	59711 59899	0.LC 0	RBU RBU	165 165	15 15
Patriot w/Factory Roof Rails	08-17	59711 59899	0.LC 0	RBU RBU	165 165	15 15
Renegade w/Factory Roof Rails	15-16	59686	0	REX	165	
KIA						
Borrego w/Factory Roof Rails	09-11	59898 59899	0 0.LB	RBU RBU	165 165	15 15
Forte 4 Dr. Sedan, Except w/Factory Roof Rails	10-13	59839	0	GTX	110	15

MODEL / STYLE	YEAR	PART NO.	FN	MS	WC	IN
KIA (Continued)						
Forte 5 Dr. Hatchback, Except w/Factory Roof Rails	11-13	59708	0	GTX	110	15
Forte 4 Dr. Sedan, Except w/Factory Roof Rails	14-17	59771	0	GTX	110	15
Forte 5 Dr. Hatchback, Except w/Factory Roof Rails	14-17	59788	0	GTX	110	15
Optima Except w/Factory Roof Rails	11-15	59896	0	GTX	110	15
Rio 4 Dr. Sedan	06-11	59801†	0	RM	110	15
Rio 4 Dr. Sedan	12-16	59735	0	GTX	110	5
Rio 5 Dr. Hatchback, Except w/Factory Roof Rails	12-16	59712	0	GTX	110	5
Rio5 5 Dr. Hatchback	06-11	59801†	0	RM	110	15
Sedona w/Factory Roof Rails	06-09	59898 59899	0 0.LB	RBU RBU	165 165	15 15
Sedona w/Factory Roof Rails	10-12	59871 59898 59899	0 0 0.LB	RB RBU RBU	165 165 165	15 15 15
Sedona w/Factory Roof Rails	14	59871 59898	0 0	RB RBU	165 165	15 15
Sedona Except Panoramic Sunroof	15-16	59684	0	REX	110	10
Sorento w/Factory Roof Rails	03-09	59898 59899	0 0.LB	RBU RBU	165 165	15 15
Sorento w/Factory Roof Rails	11-13	59898 59899	0 0.LB	RBU RBU	165 165	15 15
Sorento w/Factory Roof Rails & No Panoramic Sunroof	11-15	59868	0	RBXL	165	15
Sorento w/Factory Roof Rails & Panoramic Sunroof	11-13	59869	0	RBXL	165	15
Sorento w/Factory Roof Rails & Panoramic Sunroof	14-15	59784	0.LE	REX	110	5
Soul Except w/Factory Roof Rails	10-13	59842	0	GTX	110	15
Soul w/Factory Roof Rails	10-13	59818†	0	RB	110	15
Soul w/Anchor Points, Except w/Factory Roof Rails	14-16	59789	0	AP-GTX	165	15
Soul w/Factory Roof Rails (Canada Only)	14-16	59790	0	REX	110	15
Spportage w/Factory Roof Rails	05-10	59808† 59898 59899	0 0 0.LB	RB RBU RBU	110 165 165	15 15 15
Spportage w/Factory Roof Rails	11-16	59849	0	REX	110	5
LEXUS						
GX470 w/Factory Roof Rails	03-09	59898 59899	0 0.LB	RBU RBU	165 165	15 15
RX330 w/Factory Roof Rails	04-06	59898	0	RBU	165	15
RX350 w/Factory Roof Rails	07-09	59898	0	RBU	165	15
RX350 w/Factory Roof Rails	10-15	59817 59898	0 0	RBXL RBU	165 165	5 15
RX400h Hybrid, w/Factory Roof Rails	06-08	59898	0	RBU	165	15
RX450h Hybrid, w/Factory Roof Rails	10-12	59898	0	RBU	165	15
LINCOLN						
Aviator w/Factory Roof Rails	03-05	59897 59898	0 0.LA	RBU RBU	165 165	15 15
MKX Except w/Factory Roof Rails	07-15	59770	0	GTX	110	5
MKX w/Factory Roof Rails	07-15	59899	0	RBU	165	15
Navigator w/Factory Roof Rails	98-06	59898	0	RBU	165	15
MAZDA						
2	11-14	59830 59713 59714	0 0 0.LA	APX APE APE	100 110 110	5 5 5
3 4 Dr. Sedan	04-09	59714 59715	0 0.LB	APE APE	110 110	5 5
3 5 Dr. Hatchback	04-09	59714 59715	0 0.LB	APE APE	110 110	5 5
3 4 Dr. Sedan	10-13	59714 59715 59832	0 0.LB 0	APE APE AP-GTX	110 110 110	5 5 10

ROOF RACK APPLICATION GUIDE (CONTINUED)



MODEL / STYLE	YEAR	PART NO.	FN	MS	WC	IN
MAZDA (Continued)						
3 5 Dr. Hatchback	10-13	59714	0	APE	110	5
		59715	0, LB	APE	110	5
		59833	0	AP-GTX	110	10
5	06-10	59834	0	APE	110	10
5	12-16	59834	0	APE	110	10
6 Sport Wagon w/Factory Roof Rails	04-07	59711	0, LC	RBU	165	15
		59899	0	RBU	165	15
6 4 Dr. Sedan, Except w/Factory Roof Rails	09-13	59709	0	GTX	110	10
CX-5 Except w/Factory Roof Rails	13-16	59767	0	GTX	110	5
CX-7 Except w/Factory Roof Rails	07-12	59821	0	APX	100	15
		59714	0	APE	110	5
		59715	0, LB	APE	110	5
CX-9 Except w/Factory Roof Rails	07-13	59715	0	APE	110	5
CX-9 w/Factory Roof Rails	07-16	59899	0	RBU	165	15
CX-9 w/Factory Roof Rails	10-13	59711	0, LC	RBU	165	15
MPV w/Factory Roof Rails	00-06	59897	0	RBU	165	15
Tribute w/Factory Roof Rails	08-11	59711	0, LC	RBU	165	15
		59899	0	RBU	165	15
MERCEDES-BENZ						
C240 Wagon, w/Factory Roof Rails	03-05	59899	0	RBU	165	15
C320 Wagon, w/Factory Roof Rails	02-04	59899	0	RBU	165	15
E280 4 Dr. Sedan	07	59762	0	APE	110	5
		59763	0, LB	APE	110	5
E300 4 Dr. Sedan	08-09	59762	0	APE	110	5
		59763	0, LB	APE	110	5
E320 Wagon, w/Factory Roof Rails	98-05	59899	0	RBU	165	15
E320 4 Dr. Sedan	03-09	59762	0	APE	110	5
		59763	0, LB	APE	110	5
E350 4 Dr. Sedan	06-09	59762	0	APE	110	5
		59763	0, LB	APE	110	5
E350 Wagon, w/Factory Roof Rails	06-08	59899	0	RBU	165	15
E350 Wagon, w/Factory Roof Rails	11	59899	0	RBU	165	15
E500 4 Dr. Sedan	03-06	59762	0	APE	110	5
		59763	0, LB	APE	110	5
E500 Wagon, w/Factory Roof Rails	04-06	59899	0	RBU	165	15
E55 AMG 4 Dr. Sedan	03-06	59762	0	APE	110	5
		59763	0, LB	APE	110	5
E55 AMG Wagon, w/Factory Roof Rails	06	59899	0	RBU	165	15
E550 4 Dr. Sedan	07-09	59762	0	APE	110	5
		59763	0, LB	APE	110	5
E63 AMG 4 Dr. Sedan	07-09	59762	0	APE	110	5
		59763	0, LB	APE	110	5
E63 AMG Wagon, w/Factory Roof Rails	07-08	59899	0	RBU	165	15
GL320 BlueTEC 4Matic w/Factory Roof Rails	09	59899	0	RBU	165	15
GL320 CDI w/Factory Roof Rails	07-08	59899	0	RBU	165	15
GL350 BlueTEC 4Matic w/Factory Roof Rails	10-15	59899	0	RBU	165	15
GL450 w/Factory Roof Rails	07-16	59899	0	RBU	165	15
GL550 w/Factory Roof Rails	08-15	59899	0	RBU	165	15
GLK350 w/Factory Roof Rails	10-15	59898	0	RBU	165	15
		59899	0, LB	RBU	165	15
ML320 w/Factory Roof Rails	98-02	59899	0	RBU	165	15
ML320 BlueTEC 4Matic w/Factory Roof Rails	09	59812	0	RBXL	165	5
		59899	0	RBU	165	15
ML320 CDI w/Factory Roof Rails	07-08	59812	0	RBXL	165	5
		59899	0	RBU	165	15
ML350 w/Factory Roof Rails	03-05	59899	0	RBU	165	15
ML350 w/Factory Roof Rails	06-11	59812	0	RBXL	165	5
		59899	0	RBU	165	15
ML350 w/Factory Roof Rails	12-15	59899	0	RBU	165	15
ML350 BlueTEC 4Matic w/Factory Roof Rails	10-11	59812	0	RBXL	165	5
		59899	0	RBU	165	15

MODEL / STYLE	YEAR	PART NO.	FN	MS	WC	IN
MERCEDES-BENZ (Continued)						
ML350 BlueTEC 4Matic w/Factory Roof Rails	12-14	59899	0	RBU	165	15
ML430 w/Factory Roof Rails	99-01	59899	0	RBU	165	15
ML450 Hybrid, w/Factory Roof Rails	10-11	59812	0	RBXL	165	5
		59899	0	RBU	165	15
ML500 w/Factory Roof Rails	02-07	59899	0	RBU	165	15
ML500 w/Factory Roof Rails	06-07	59812	0	RBXL	165	5
ML550 w/Factory Roof Rails	08-11	59812	0	RBXL	165	5
ML550 w/Factory Roof Rails	08-15	59899	0	RBU	165	15
ML63 AMG w/Factory Roof Rails	07-11	59812	0	RBXL	165	5
ML63 AMG w/Factory Roof Rails	07-15	59899	0	RBU	165	15
MERCURY						
Mariner w/Factory Roof Rails	08-11	59897	0	RBU	165	15
		59898	0, LA	RBU	165	15
Monterey w/Factory Roof Rails	04-07	59897	0	RBU	165	15
		59898	0, LA	RBU	165	15
MINI						
Cooper Clubman w/Factory Roof Rails	08-10	59897	0	RBU	165	15
MITSUBISHI						
Lancer 5 Dr. Hatchback, Except w/Factory Roof Rails	10-17	59834	0	APE	110	10
Outlander Except w/Factory Roof Rails	07-17	59834	0	APE	110	10
Outlander w/Factory Roof Rails (Except Outlander Sport)	07-12	59899	0	RBU	165	15
Outlander Sport Except w/Factory Roof Rails	11-16	59834	0	APE	110	10
NISSAN						
Frontier w/Aftermarket Fiberglass Flat Roof Cap or Tonneau	05-13	59753	U, H, U, J	DMS	165	30
		59855	U, H, U, J	TRS	165	40
Murano w/Factory Roof Rails	03-07	59898	0	RBU	165	15
		59899	0, LB	RBU	165	15
Murano w/Factory Roof Rails	09-14	59823	0	RBXL	165	5
		59898	0	RBU	165	15
		59899	0, LB	RBU	165	15
Pathfinder w/Factory Roof Rails	13-16	59899	0	RBU	165	15
Quest w/Factory Roof Rails	04-09	59711	0, LC	RBU	165	15
Quest w/Factory Roof Rails	04-09	59899	0	RBU	165	15
		59899	0	RBU	165	15
Quest w/Factory Roof Rails	11-16	59711	0, LC	RBU	165	15
		59899	0	RBU	165	15
Rogue w/Factory Roof Rails	08-16	59824	0	RBXL	165	5
		59898	0	RBU	165	15
Titan	04-16	59754	U, G, U, J	DMS	165	45
		59853	U, G, U, J	TRS	165	60
Titan w/Aftermarket Fiberglass Flat Roof Cap or Tonneau	04-16	59753	U, H, U, J	DMS	165	30
Titan w/Factory Bed Channel System (Deck Rail System)	04-16	59855	U, H, U, J	TRS	165	40
Titan w/Factory Bed Channel System (Deck Rail System)	04-16	59799		TBR	800	40
OLDSMOBILE						
Silhouette w/Factory Roof Rails	97-04	59898	0	RBU	165	15
		59899	0, LB	RBU	165	15
PONTIAC						
Montana w/Factory Roof Rails	99-05	59898	0	RBU	165	15
		59899	0, LB	RBU	165	15
Montana SV6 w/Factory Roof Rails	05-06	59898	0	RBU	165	15
		59899	0, LB	RBU	165	15
Montana SV6 w/Factory Roof Rails (Canada Only)	07-09	59898	0	RBU	165	15
		59899	0, LB	RBU	165	15
Trans Sport w/Factory Roof Rails	97-98	59898	0	RBU	165	15
Vibe Except w/Factory Roof Rails	03-10	59721	0	APX	110	5
		59722	0	APE	110	5
Vibe w/Factory Roof Rails	03-10	59897	0	RBU	165	15
		59898	0, LA	RBU	165	15

ROOF RACK APPLICATION GUIDE (CONTINUED)



MODEL / STYLE	YEAR	PART NO.	FN	MS	WC	IN
PORSCHE						
Cayenne w/Factory Roof Rails	03-06	59898	0	RBU	165	15
Cayenne w/Factory Roof Rails	08-16	59898	0	RBU	165	15
RAM						
1500	11-17	59754	UG,UJ	DMS	165	45
		59853	UG,UJ	TRS	165	60
1500 Except w/RamBox Cargo Management System	11-17	59742	0,UJ	TBR	400	40
1500 w/Aftermarket Fiberglass Flat Roof Cap or Tonneau	11-17	59753	UH,UJ	DMS	165	30
		59855	UH,UJ	TRS	165	40
2500	11-17	59754	UG,UJ	DMS	165	45
		59853	UG,UJ	TRS	165	60
2500 Except w/RamBox Cargo Management System	11-17	59742	0,UJ	TBR	400	40
2500 w/Aftermarket Fiberglass Flat Roof Cap or Tonneau	11-17	59753	UH,UJ	DMS	165	30
		59855	UH,UJ	TRS	165	40
3500	11-17	59754	UG,UJ	DMS	165	45
		59853	UG,UJ	TRS	165	60
3500 Except w/RamBox Cargo Management System	11-16	59742	0,UJ	TBR	400	40
3500 w/Aftermarket Fiberglass Flat Roof Cap or Tonneau	11-17	59753	UH,UJ	DMS	165	30
		59855	UH,UJ	TRS	165	40
Dakota	11	59754	UG,UJ	DMS	165	45
		59853	UG,UJ	TRS	165	60
		59742	0,UJ	TBR	400	40
Dakota w/Aftermarket Fiberglass Flat Roof Cap or Tonneau	11	59753	UH,UJ	DMS	165	30
		59855	UH,UJ	TRS	165	40
ProMaster City	15-17	59631		APE	165	15
		59632		APE	165	15
		59633		APE	165	15
SAAB						
9-5 Wagon, w/Factory Roof Rails	99-09	59898	0	RBU	165	15
9-7X w/Factory Roof Rails	05-09	59898	0	RBU	165	15
SATURN						
Astra 3 Dr. Hatchback, w/Anchor Points	08-09	59761	0	APE	110	5
Astra 5 Dr. Hatchback, w/Anchor Points	08-09	59761	0	APE	110	5
LW1 Wagon, w/Factory Roof Rails	00	59898	0	RBU	165	15
		59899	0,LB	RBU	165	15
LW2 Wagon, w/Factory Roof Rails	00	59898	0	RBU	165	15
		59899	0	RBU	165	15
LW200 Wagon, w/Factory Roof Rails	01-03	59898	0	RBU	165	15
		59899	0	RBU	165	15
LW300 Wagon, w/Factory Roof Rails	01-03	59898	0	RBU	165	15
		59899	0	RBU	165	15
Vue w/Factory Roof Rails	08-09	59898	0	RBU	165	15
SUBARU						
Crosstrek Except w/Factory Roof Rails	16	59636	0	APE	165	10
Crosstrek w/Factory Roof Rails	16	59898	0	RBU	165	15
Forester Except w/Factory Roof Rails	09-16	59636	0	APE	165	10
Forester w/Factory Roof Rails	09-13	59898	0	RBU	165	15
		59899	0,LB	RBU	165	15
Impreza 4 Dr. Sedan, Except w/Factory Roof Rails	08-11	59636	0	APE	165	10
Impreza 5 Dr. Wagon, Except w/Factory Roof Rails	08-16	59636	0	APE	165	10
Legacy Wagon, w/Factory Roof Rails	95-99	59897	0	RBU	165	15
Outback Wagon, w/Factory Roof Rails, Except Sport	00-09	59897	0	RBU	165	15
Tribeca w/Factory Roof Rails	08-14	59899	0	RBU	165	15
WRX 4 Dr. Sedan, Except w/Factory Roof Rails	12-14	59636	0	APE	165	10
WRX 5 Dr. Wagon, Except w/Factory Roof Rails	12-15	59636	0	APE	165	10
XV Crosstrek Except w/Factory Roof Rails	13-15	59636	0	APE	165	10
XV Crosstrek w/Factory Roof Rails	13	59899	0,LB	RBU	165	15
XV Crosstrek w/Factory Roof Rails	13-15	59898	0	RBU	165	15

MODEL / STYLE	YEAR	PART NO.	FN	MS	WC	IN
SUZUKI						
Esteem Wagon, w/Factory Roof Rails	98-02	59897	0	RBU	165	15
Forenza Wagon, w/Factory Roof Rails	05-08	59897	0	RBU	165	15
Grand Vitara w/Factory Roof Rails	99-05	59897	0	RBU	165	15
SX4 Crossover, w/Factory Roof Rails	07-14	59897	0	RBU	165	15
		59898	0,LA	RBU	165	15
Vitara 4 Dr., w/Factory Roof Rails	99-04	59897	0	RBU	165	15
XL-7 w/Factory Roof Rails	02-06	59897	0	RBU	165	15
		59898	0,LA	RBU	165	15
TOYOTA						
4Runner w/Factory Roof Rails	03-16	59898	0	RBU	165	15
		59899	0,LB	RBU	165	15
Camry 4 Dr. Sedan	07-11	59733	0	GTX	110	5
Corolla 4 Dr. Sedan	09-13	59734	0	GTX	110	5
FJ Cruiser Except w/Factory Roof Rails	07-14	59724	0	APE	110	5
FJ Cruiser w/Factory Roof Rails	07-14	59898	0	RBU	165	15
		59899	0,LB	RBU	165	15
Highlander Except w/Factory Roof Rails	01-13	59723	0	APE	110	5
		59724	0,LC	APE	110	5
Highlander w/Factory Roof Rails	01-13	59899	0	RBU	165	15
Matrix Except w/Factory Roof Rails	03-10	59721	0	APX	110	5
		59722	0	APE	110	5
Matrix w/Factory Roof Rails	03-10	59897	0	RBU	165	15
		59898	0,LA	RBU	165	15
Prius	04-09	59728	0	GTX	110	5
Prius V	12-17	59729	0	GTX	110	5
RAV4 Except w/Factory Roof Rails	01-12	59723	0	APE	110	5
		59724	0,LC	APE	110	5
RAV4 w/Factory Roof Rails	01-12	59899	0,LB	RBU	165	15
RAV4 w/Factory Roof Rails	01-17	59898	0	RBU	165	15
Sequoia w/Factory Roof Rails	08-13	59711	0	RBU	165	15
Sienna w/Factory Roof Rails	04-10	59711	0,LC	RBU	165	15
		59899	0	RBU	165	15
Sienna w/Factory Roof Rails	11-17	59898	0	RBU	165	15
		59899	0,LB	RBU	165	15
TACOMA						
Tacoma	96-17	59754	UG,UJ	DMS	165	45
		59853	UG,UJ	TRS	165	60
Tacoma w/Aftermarket Fiberglass Flat Roof Cap or Tonneau	96-17	59753	UH,UJ	DMS	165	30
		59855	UH,UJ	TRS	165	40
Tacoma 4 Dr. Access Cab, Except w/Factory Roof Rails	05-17	59752	0	GTX	110	5
Tacoma w/Factory Bed Channel System (Deck Rail System)	05-17	59799		TBR	800	40
Tundra	00-17	59754	UG,UJ	DMS	165	45
		59853	UG,UJ	TRS	165	60
Tundra Except w/Integrated Deck Rail Systems	00-17	59742	0,UJ	TBR	400	40
Tundra w/Aftermarket Fiberglass Flat Roof Cap or Tonneau	00-17	59753	UH,UJ	DMS	165	30
		59855	UH,UJ	TRS	165	40
Tundra w/Factory Bed Channel System (Deck Rail System)	07-17	59799		TBR	800	40
Venza Except w/Factory Roof Rails	09-15	59731	0,LE	GTX	110	5
VOLKSWAGEN						
CC	09-16	59737	0	GTX	110	5
Golf 2 Dr. Hatchback	10-16	59736	0	GTX	110	5
Golf 3 Dr. Hatchback (Canada Only)	10-16	59736	0	GTX	110	5
Golf 4 Dr. Hatchback	10-16	59736	0	GTX	110	5
Golf 5 Dr. Hatchback (Canada Only)	10-16	59736	0	GTX	110	5
Golf Wagon (Canada Only), w/Factory Roof Rails	10-15	59820	0	RBLX	165	5
		59897	0	RBU	165	15
		59898	0,LA	RBU	165	15
Golf R 2 Dr. Hatchback	12-15	59736	0	GTX	110	5
Golf R 4 Dr. Hatchback	12-15	59736	0	GTX	110	5
Golf R 5 Dr. Hatchback (Canada Only)	12-15	59736	0	GTX	110	5
GTI 2 Dr. Hatchback	10-15	59736	0	GTX	110	5
GTI 3 Dr. Hatchback (Canada Only)	10-14	59736	0	GTX	110	5

ROOF RACK APPLICATION GUIDE (CONTINUED) & FOOTNOTES



MODEL / STYLE	YEAR	PART NO.	FN	MS	WC	IN
VOLKSWAGEN (Continued)						
GTI 4 Dr. Hatchback	10-15	59736	Ø	GTX	110	5
GTI 5 Dr. Hatchback (Canada Only)	10-14	59736	Ø	GTX	110	5
Jetta Wagon, w/Factory Roof Rails	01-06	59897	Ø	RBU	165	15
		59898	Ø,LA	RBU	165	15
Jetta SportWagon w/Factory Roof Rails	09-13	59820	Ø	RBXL	165	5
		59897	Ø	RBU	165	15
		59898	Ø,LA	RBU	165	15
Jetta Wagon (Canada Only), w/Factory Roof Rails	09	59820	Ø	RBXL	165	5
		59897	Ø	RBU	165	15
		59898	Ø,LA	RBU	165	15
Passat Wagon, w/Factory Roof Rails	90-05	59897	Ø	RBU	165	15
Passat Wagon, w/Factory Roof Rails	07-10	59719f	Ø	RBXL	165	10
		59897	Ø	RBU	165	15
Passat 4 Dr. Sedan	12-17	59738	Ø	GTX	110	5
Tiguan w/Factory Roof Rails	09-16	59898	Ø	RBU	165	15
Touareg w/Factory Roof Rails	04-17	59898	Ø	RBU	165	15
VOLVO						
V50 Wagon, w/Factory Roof Rails	05-11	59898	Ø	RBU	165	15
V70 Wagon, w/Factory Roof Rails	01-10	59898	Ø	RBU	165	15
XC70 Wagon, AWD, w/Factory Roof Rails	03-14	59898	Ø	RBU	165	15
XC90 w/Factory Roof Rails	03-14	59897	Ø	RBU	165	15

FOOTNOTES	
†	Available while supplies last.
LA	Optional Wider 47-1/4" (1200mm) Length Cross Bar.
LB	Optional Wider 51-1/8" (1300mm) Length Cross Bar.
LC	Optional Wider 55-1/8" (1400mm) Length Cross Bar.
LE	Vehicles sunroof is not operable on models with optional glass roof when roof rack is installed.
Ø	Uses all existing holes. No drilling required.
UG	Some track systems may require cutting shorter to fit due to various roof lengths.
UH	Some track systems may require cutting shorter to fit due to various truck bed lengths.
UI	This rack system requires access under the bed side rails to attach. Some bed sides especially those with integrated bed side rails may not work with this rack system.
UJ	Direct and Track mount systems require the use of #59772 (51-1/4" / 1300mm), #59773 (55-1/8" / 1400mm) or #59774 (63" / 1600mm) cross bars.



ROOF RACKS ACCESSORIES / REPLACEMENT PARTS / SERVICE KITS

Part No.	Description
Lock & Keys Replacements / Service Kits	
38374-*	Locks & Keys, fit ROLA lockable roof racks and other ROLA accessories. (* specify key/lock core number when ordering)
38373-*	Keys, fit ROLA lockable roof racks and other ROLA accessories (* specify key number when ordering)
59703	Quarter Turn Plugs (4 per poly bag)
Service Kits	
38371	T-27 T-Handle Torx Driver (2 per poly bag)
59847	T-27 L-Handle Torx Driver (2 per poly bag)
59846	Cross Bar Buffer Strips (2 per poly bag)
59701	M6 x 30MM Bolts (4 per poly bag)
59702	M6 x 50MM Bolts (4 per poly bag)
59710	M6-1 Cage Nuts (4 per poly bag)
GTX Series Replacements / Service Kits	
59887	Support Cover Kit (Includes: (1) Left Hand Cover, (1) Right Hand Cover, (2) Hinges & (2) Dummy Locks)
38429	Self-Adhesive Rubber Mounting Pads (4 per poly bag)
38422	Mounting Pads for #59842 roof racks (4 per box)
38423	Mounting Pads for roof racks (4 per box)
38424	Mounting Pads for roof rack (4 per box)
38425	Mounting Pads for #59800 roof rack (4 per box)
38426	Mounting Pads for #59867 roof rack (4 per box)
REX Series Replacements / Service Kits	
59750	Cross Bar T-Handle 5mm Hex Driver
59745	Cross Bar End Cap
APE Series Replacements / Service Kits	
59746	APE-RE Series Cross Bar Undercover (2 per poly bag)
59772	Roof Rack, Removable Anchor Point Extended APE Series - Track/Direct Mount, Bar Length 51-1/4" (1300mm)
59773	Roof Rack, Removable Anchor Point Extended APE Series - Track/Direct Mount, Bar Length 55-1/8" (1400mm)
59774	Roof Rack, Removable Anchor Point Extended APE Series - Track/Direct Mount, Bar Length 63" (1600mm)
RBXL Series Replacements / Service Kits	
59886	Support Locking Covers (2 per poly bag)
38428	Self-Adhesive Rubber Mounting Pads (4 per box)
RB Series Replacements / Service Kits	
38427	Self-Adhesive Rubber Mounting Pads(4 per box)
RBU Series Replacements / Service Kits	
59749	Cross Bar Buffer Strips (2 per poly bag)
59748	Cross Bar End Support
59747	Cross Bar Undercover (2 per poly bag)
59745	Cross Bar End Cap
Roof Rack Bolts	
59785	Replacement Part, Bolts (4) M6 x 55MM

AUTOMOTIVE RATCHET TIE DOWNS



1152101



1154000



1160400

Part No.	Description	Duty Rating	Load Capacity (lbs)	Break Strength (lbs)	Color	Packaging
1152101	Ratchet Tie Down w/Padded Handle - 1" x 6'	Std	600	1800	Orange	Open (2-pack)
1153500	Retractable Ratchet Tie Down - 1" x 6'	Std	400	1200	Camo	Open (2-pack)
1151801	Retractable Ratchet Tie Down - 1" x 6' (motorcycle)	Std	500	1500	Black	Open (2-pack)
1154000	Retractable Ratchet Tie Down - 2" x 10', 1100 lbs.	Heavy	1100	3300	Black	Bulk (Single)
1151601	Ratchet Tie Down w/Hooks- 1-1/4" x 10'	Heavy	1100	3300	Yellow	Open (2-pack)
1160400	Ratchet Tie Down w/Reflective Webbing (ATV) - 1" x 12'	Heavy	1100	3300	Black	Open (4-pack)
1151701	Ratchet Tie Down w/Hooks- 1-1/2" x 15'	Super	1830	5500	Yellow	Open (Single)
1152500	HD Ratchet Tie Down w/Hooks - 2" x 25', 10,000 lbs. - Break Strength	Super	3330	10000	Yellow	Open (Single)
1227000	Ratchet Tie Down - 1" x 10'	Light	300	900	Red	Open (Single)
9010500	Ratchet Tie Down - 1" x 10"	Std	500	1500	Orange	Open (4-pack)

FAT STRAP™ BUNGEE CORDS

- Won't damage or dig into your cargo
- Extra wide, strong and secure
- Coated steel hooks are stronger than conventional hooks



9412000

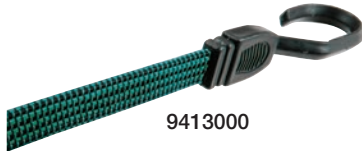

9413000



9414500

Part No.	Description	Packaging
9412000	20" Fat Strap™ Bungee	Clamshell
9413000	30" Fat Strap™ Bungee	Clamshell
9414500	45" Fat Strap™ Bungee	Clamshell
9414900	10" - 45" Adjustable Fat Strap™ Bungee	Clamshell



2902500

TRIPLE STRENGTH BUNGEE CORDS

- Coated steel hooks are 3X stronger than conventional hooks
- Won't bend, break, scratch or mar
- Color coded hooks for convenient selection
- Engineered to withstand even the harshest outdoor elements

Part No.	Description	Packaging
9528600	18" Triple Strength - Purple (2-pack)	Bulk
2902500	Triple Strength Bungee Cord Assortment (10 piece): (4) 24", (4) 32", (2) 40"	Jar
2902600	Triple Strength Bungee Cord Assortment (5 piece): (2) 18", (2) 24", (1) 32"	Jar

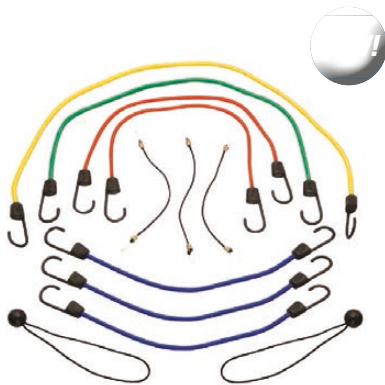

9528800

BUNGEE CORDS

- Coated steel hooks
- Won't bend, break, scratch or mar
- Color coded for convenient selection
- Engineered to withstand even the harshest outdoor elements

Part No.	Description	Packaging
9528800	Heavy Duty Bungee Cord Assortment (12 piece): (3) Mini, (3) - 18", (2) - 24", (1) - 32", (1) - 40", (2) Canopy Ties	Jar
9527300	Heavy Duty Bungee Cord Assortment (24 piece): (6) Mini, (6) - 18", (4) - 24", (2) - 32", (2) - 40", (4) Canopy Ties	Jar

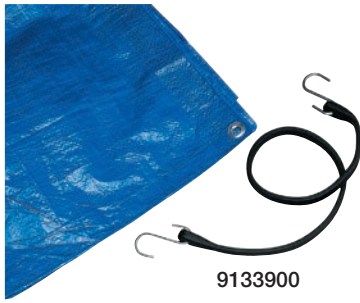

9133900

TARP STRAPS

UV-resistant EDPM rubber maintains strength and performance in all weather conditions.



Part No.	Description	Packaging
9429300	6 pc. Tarp Strap Assortment: 2 - 15", 2- 21", 2 - 31"	Jar



9514600

TRAILERING TIE DOWNS

- Safely secures many kinds of vehicles to trailers for transportation
- Constructed with heavy duty non-slip ratchets and weather resistant webbing
- Engineered for maximum tension and easy release
- Heavy duty axle strap with high tensile steel rings allows easy, secure trailering of vehicle, using vehicle axle
- Over-the-wheel tie down design, secures vehicles to trailer

Part No.	Description
9514600	1-1/2" x 7' Ratchet Tie Down, 6,000 lbs. Break Strength, 2,000 lbs. Load Capacity



9426400

9534000

TOW STRAPS

- Tow Straps are made of heavy duty, 10,000 lbs. capacity Power Web™ webbing with zinc plated forged hooks
- For recovery purposes only

Part No.	Description
9534000	2" x 20' Tow Strap w/Hooks, 10,000 lbs. Break Strength
9426400	2" x 20' Tow Strap w/Loop Ends, 17,000 lbs. Break Strength



59204

LIGHT DUTY LASHING STRAP



- Lashing strap design for luggage or light duty carrying & securing needs

Part No.	Description	Duty Rating	Load Capacity (lbs)	Break Strength (lbs)	Color	Packaging
59204	Lashing Strap - 1" x 10'	Lashing	55	165	Black	Clamshell (2-pack)



TITAN RATCHET TIE DOWNS

- Ratchet tie downs provide super strong holding power with precise tension adjustment
- Stylish cast aluminum handle with padded grip
- Curved release both for easy release



9425900



9426100

Part No.	Description	Duty Rating	Load Capacity (lbs)	Break Strength (lbs)	Color	Packaging
9425900	Titan Ratchet Tie Down, 1" x 6'	Std	600	1800	Black	Open (2-pack)
9426100	Titan Ratchet Tie Down, 1" x 10'	Std	600	1800	Black	Open (4-pack)

TITAN MAX GRIP RATCHET TIE DOWNS

- Full open grip handle, fits any sized hand comfortably
- Cast aluminum handled ratchets
- Curved release button for smooth release



9426001



9426200

Part No.	Description	Duty Rating	Load Capacity (lbs)	Break Strength (lbs)	Color	Packaging
9426001	Titan Max Grip Ratchet Tie Down, 1" x 14'	Heavy	1000	3000	Black	Open (2-pack)
9426200	Titan Max Grip Ratchet Tie Down, 1" x 14'	Heavy	1000	3000	Black	Open (4-pack)

MARINE CAMBUCKLE TIE DOWNS



2060066

Bow Cambuckles



- Vinyl coated S-hooks protect boats finish
- Provides super strong holding power
- Some models available with stainless steel housing

Transom Cambuckles



- Locks in place to eliminate slippage
- Protective housing prevents scratches
- Some models available with stainless steel housing

Part No.	Description	Duty Rating	Load Capacity (lbs)	Break Strength (lbs)	Color	Packaging
2060166	Cambuckle Tie Down w/Hooks - (Bow) 1" x 36", Stainless Steel	Light	300	900	Black	Clam Shell (2-pack)
2060066	Cambuckle Tie Down w/Hooks - (Bow) 1" x 36", Zinc	Standard	400	1200	Black	Clam Shell (2-pack)
2060466	Surelok Cambuckle Tie Down - (Transom) 2" x 24", Zinc	Heavy Duty	833	2500	Black	Open (2-pack)
2060766	Surelok Cambuckle Tie Down - (Transom) 2" x 48", Zinc	Heavy Duty	833	2500	Black	Poly Bag (Single)

MARINE RATCHET TIE DOWNS



2060266



2061566

Retractable Transom Ratchets



- Strap retracts for easy storage and no tangling
- Easy bolt on function (hardware included)
- Some models available with stainless steel housing

Gunwale Ratchets



- Vinyl coated J-hooks protect boats finish
- Provides super strong holding power
- Some models available with stainless steel housing

Part No.	Description	Duty Rating	Load Capacity (lbs)	Break Strength (lbs)	Color	Packaging
2060266	Retractable Tie Down - (Transom) 2" x 43", Stainless Steel	Standard	600	1800	Black	Open (2-pack)
2061766	Retractable Tie Down - (Transom) 2" x 43", Zinc	Heavy Duty	833	2500	Black	Poly Bag (Single)
2060366	Retractable Tie Down - (Transom) 2" x 43", Zinc	Heavy Duty	833	2500	Black	Open (2-pack)
2060866	Max Grip Ratchet - (Gunwale) 2" x 10', Stainless Steel	Light	333	1000	Black	Open (Single)
2060966	Max Grip Ratchet - (Gunwale) 2" x 13', Stainless Steel	Standard	400	1200	Black	Open (Single)
2061266	Max Grip Ratchet - (Gunwale) 2" x 10', Zinc	Heavy Duty	833	2500	Black	Open (Single)
2061366	Max Grip Ratchet - (Gunwale) 2" x 13', Zinc	Heavy Duty	833	2500	Black	Open (Single)
2061466	Max Grip Ratchet - (Gunwale) 2" x 16', Zinc	Heavy Duty	833	2500	Black	Open (Single)
2061566	Max Grip Ratchet - (Gunwale) 2" x 20', Zinc	Heavy Duty	833	2500	Black	Open (Single)



9424100

TRUCK NET

- Bungee material stretches to fit
- 60" x 78"
- Only use for light loads



Part No.	Description	Packaging
9424100	Truck Net - 60"X78" Pickup	Display Box



9424200

TRUCK NET UNIVERSAL ADJUSTABLE

- 55" x 78"
- End sections fold to fit shorter beds
- Only use for light loads

Part No.	Description	Packaging
9424200	Truck Net Universal Adjustable	Display Box



1390800

UNIVERSAL PET BARRIER

- Pet Barrier gently keeps your pet in the cargo area of your vehicle
- Sleek, modern styling
- Made with heavy gauge tubing, the Pet Barrier fits all mini-vans and SUVs
- Installs in minutes

Part No.	Description	Packaging
1390800	Universal Pet Barrier 65" x 45"	Display Box

**FULTON®
PROUD SPONSOR OF
BRENT CHAPMAN**



JACKS / COUPLERS / WINCHES

UTILITY JACKS

Round Jacks.5-10
 Square Jacks.11-14
 Heavy Duty Square Jacks.15-20
 Twin Cam Drop Leg Jack.17
 2-Speed Square Jacks.18
 Heavy Duty 2-Speed Tandem Landing Gear.21
 Fifth Wheel Landing Gear System.22
 Rack / Gear Jacks.23-24
 Jack Part Kits.25-28
 Multi-Jack.36
 Stabilizers.36

MARINE & RECREATIONAL JACKS

Marine / Recreational Jacks.29-35
 F2® Marine / Recreational Jacks.29-31
 XLT™ Marine / Recreational Jacks.32

JACKS WITH POWERED DRIVE

A-Frame Jacks with Powered Drive.3-4
 Powered Drive Kits.19
 Velocity Series™ High Speed Jacks.21

COUPLERS

Heavy Duty Collar-Lok™ Couplers.37-38
 Heavy Duty Cast Couplers.39-40
 Gooseneck Couplers.41-44
 BX1® Gooseneck Couplers.43
 Stamped Couplers.45-46
 Fold-Away™ Hinge Kits.47

HAND WINCHES

Hand Winch Selector.48
 F2® Trailer Winches.49-50
 Single Speed Trailer Winches.51-52
 Two Speed Trailer Winches.53-54
 Brake Winches.55-56

POWER WINCHES & HOISTS

Utility Winches.57-58
 Heavy Duty Winches.59-60
 Hydraulic Winches.61
 Electric Hoists.62
 Winch Accessories / Replacement Parts.63-64

NEW PRODUCTS



A-FRAME JACK WITH POWERED DRIVE

- Heavy duty 4,000 lbs. lift capacity
- Built-in level and onboard LED courtesy light

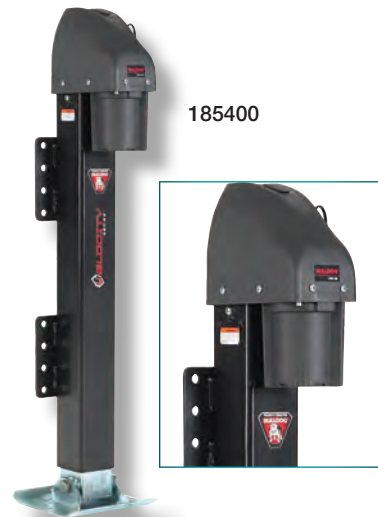

VELOCITY SERIES™ HIGH SPEED JACKS

- Fully powered - 12,000 lbs. capacity per leg
- Includes wired remote



UTILITY DUTY WINCHES

- 9,000 - 12,000 lbs. capacities
- Power in and power out for powerful retraction and rapid rope payout



XLT™ SINGLE SPEED TRAILER WINCHES

- 1,500 - 1,800 lbs capacities
- Includes stylized thermoplastic covers, solid drum gear construction & 2-way ratchet pawl with neutral feature

FEATURED PRODUCTS

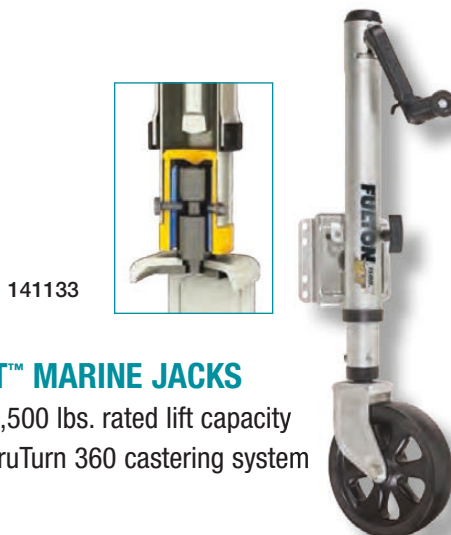

XLT™ MARINE JACKS

- 1,500 lbs. rated lift capacity
- TruTurn 360 casting system



ELECTRIC HEAVY DUTY WINCHES

- 6,000 - 18,000 lbs. rated line pull capacities
- Durable heavy duty motor delivers superior torque output and faster line speed





500200

500199

A-FRAME JACK WITH POWERED DRIVE

Tough & Trusted BULLDOG presents a Powered Jack with all the capacity and features you want.



- Heavy duty 4000 lbs. lift capacity
- Drop leg with spring loaded pull pin
- Makes setting up easier with a handy built-in level right where you need it most
- Deploys and hooks up easily at night with onboard LED courtesy light
- Works in case of power loss with emergency manual override capability, easily accessible from the top
- Lasts for years with industry-leading BULLDOG performance, known worldwide for unmatched strength, durability, and side load capacity
- Retains like-new appearance with corrosion-resistant surfaces
- 5 year limited warranty



A-FRAME JACK WITH POWERED DRIVE

Part No.	Lift Cap. (lbs.)	Travel	Measurements			Description	Pkg.	Lbs.
			Retracted	Extended	Clearance			
500199	4,000	14"	9.75"	31.75"	21.00"	Black Cover, includes Drop Leg	Ind. Pack	24
500200	4,000	14"	9.75"	31.75"	21.00"	White Cover, includes Drop Leg	Ind. Pack	24

REPLACEMENT PARTS

Part No.	Description	Packaging
500190	Drop leg and pin kit.	Ind. Pack
500191	Manual override crank bolt kit.	Polybag
500193	Level assembly and screws.	Polybag
500194	Manual override cover kit.	Polybag
500196	LED light assembly and bulbs.	Polybag
500360	Black Cover w/Mounting Screws for BULLDOG Powered Drive Tongue Jack for #500199.	Boxed
500361	White Cover w/Mounting Screws for BULLDOG Powered Drive Tongue Jack for #500200.	Boxed
500362	Light Switch for #500187, #500188, #500199 and #500200	Boxed
500363	Extend/Retract Switch for #500187, #500188, #500199 and #500200	Boxed



LED Light



Built-In Level & Emergency Manual Override



Spring-Loaded Drop Leg Pull Pin



A-FRAME JACK WITH POWERED DRIVE



Tough & Trusted BULLDOG presents a Powered Jack with all the capacity and features you want.

- Positions quickly with 22" of total travel
- 3500 lbs. lift capacity
- Integrated gearbox and motor
- Drop leg
- Deploys and hooks up easily at night with onboard LED courtesy light, angled to illuminate coupler
- Works in case of power loss with emergency manual override capability, easily accessible from the top, crank included
- Lasts for years with industry-leading BULLDOG performance, known worldwide for unmatched strength, durability, and side load capacity
- Retains like-new appearance with corrosion-resistant surfaces
- 5 year limited warranty



500187

500188

LED Courtesy Light

A-FRAME JACK WITH POWERED DRIVE

Part No.	Lift Cap. (lbs.)	Travel	Measurements			Description	Packaging	Lbs.
			Retracted	Extended	Clearance			
500187	3,500	14"	9.75"	31.50"	20.50"	Black Cover, includes Drop Leg and Manual Override Crank	Ind. Pack	20
500188	3,500	14"	9.75"	31.50"	20.50"	White Cover, includes Drop Leg and Manual Override Crank	Ind. Pack	20

REPLACEMENT PARTS

Part No.	Description	Packaging
500190	Drop leg and pin kit.	Ind. Pack
500201	Kit-Manual Override Cover	Polybag
500202	Kit-LED Light Assembly Replacement	Polybag
500203	Kit-Manual Override Crank	Boxed
500305	Kit-Replacement Cover Black	Boxed
500306	Kit-Replacement Cover White	Boxed
500362	Replacement Part, Light Switch for #500187, #500188, #500199 and #500200	Boxed
500363	Replacement Part, Extend/Retract Switch for #500187, #500188, #500199 and #500200	Boxed



500198

A-FRAME JACK WITH POWERED DRIVE

- 18" travel
- Integrated circuit breaker
- Works in case of power loss with supplied manual override crank handle
- Gloss black painted outer tube and motor assembly, clear zinc inner tube
- Limited 1 year warranty

A-FRAME JACK WITH POWERED DRIVE

Part No.	Lift Cap. (lbs.)	Travel	Measurements			Description	Pkg.	Lbs.
			Retracted	Extended	Clearance			
500198	2,500	18"	8.50"	26.50"	N/A	Powered A-Frame Jack without Footplate, Manual Override Crank Included	Ind. Pack	20

REPLACEMENT PARTS

Part No.	Description	Packaging
500204	Drive Pin & Coupling	Polybag



ROUND JACKS

BULLDOG round jacks are recognized as the industry standard by leading agricultural, commercial, horse, livestock, and other trailer manufacturers. For more than three quarters of a century, BULLDOG jacks have been demonstrated to be the most reliable, field-proven jacks on the market.

- Smooth, comfortable, ergonomic design
- Dependable vertical and side load capacity
- Proven reliability for long term use at rated loads
- Precision fitted parts for extra stability
- A-Frame models listed have grey painted outer and inner tubes - All other models have grey painted outer and clear zinc inner tubes
- Custom finishes are available upon request

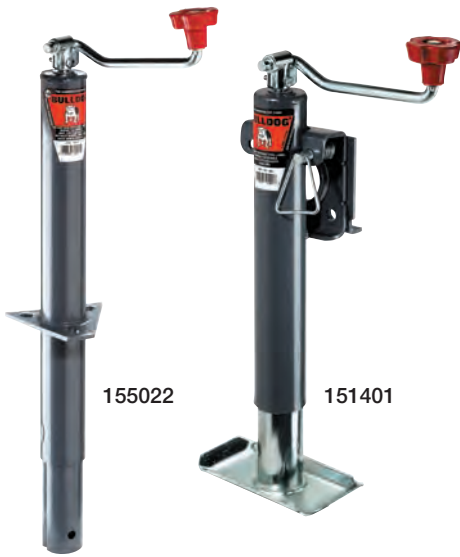

155022

151401



178201

151443

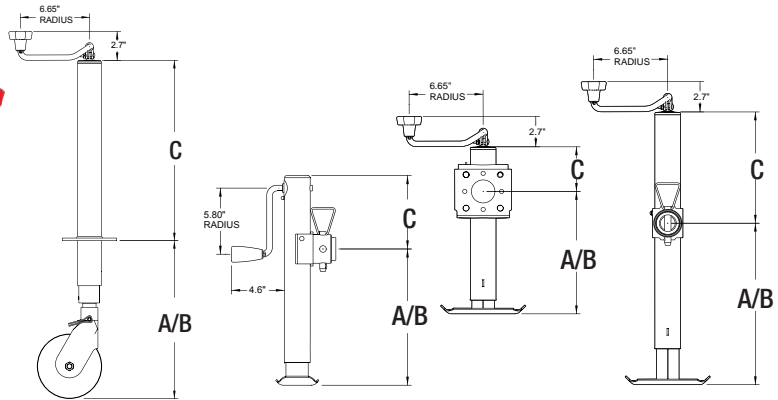

Travel and Clearance Diagram

A= Retracted B= Extended C= Clearance Height



THE CHOICE WHEN APPLICATION REQUIRES COMPLIANCE WITH ASABE S485 STANDARDS

STANDARD ROUND JACKS - TUBULAR SWIVEL - ROUND

Part No.	Model No.	Lift Cap. (lbs.)	Handle Style	Travel	Measurements			Description	Lbs.
					A Retracted	B Extended	C Clearance		
158451	TWS 158 DTSF w/P&C	2,000	Topwind	10"	11.00"	21.00"	4.00"	Weld-on tubular mount with 9/16" pin and foot plate. Male mating mount included.	13.5
1584510117	TWS 158 DTSF w/P&C	2,000	Topwind	10"	11.00"	21.00"	4.00"	Weld-on tubular mount with 9/16" pin and foot plate. Male mating mount included. Display Box.	13.5
158452	TWL 158 DTSF w/P&C	2,000	Topwind	15"	14.50"	29.50"	10.00"	Weld-on tubular mount with 9/16" pin and foot plate. Male mating mount included.	16.0
1584520117	TWL 158 DTSF w/P&C	2,000	Topwind	15"	14.50"	29.50"	10.00"	Weld-on tubular mount with 9/16" pin and foot plate. Male mating mount included. Display Box.	16.0
150441	TWS 150 DTSEFX w/P&C	2,000	Topwind	10"	11.00"	21.00"	4.00"	Weld-on tubular mount, with 9/16" pin and foot plate. Clear zinc finish. Mating mount sold separately.	10.0
158488	TWL 150 DTSEFX w/P&C	2,000	Topwind	15"	16.00"	31.00"	4.00"	Weld-on tubular mount with 9/16" pin and foot plate. Clear zinc finish. Male mating mount included.	14.2
158109	SWS 158 DTSEFX w/P&C	2,000	Sidewind	10"	10.80"	20.80"	6.40"	Weld-on tubular mount with 9/16" pin and foot plate. Male mating mount included.	14.0
1581090117	SWS 158 DTSEFX w/P&C	2,000	Sidewind	10"	10.80"	20.80"	6.40"	Weld-on tubular mount with 9/16" pin and foot plate. Male mating mount included. Display Box.	14.0

STANDARD ROUND JACKS - TUBULAR SWIVEL - ROUND (CONTINUED)

Part No.	Model No.	Lift Cap. (lbs.)	Handle Style	Travel	Measurements			Description	Lbs.
					A Retracted	B Extended	C Clearance		
158151 ♦	SWL 158 DTSF w/P&C	2,000	Sidewind	15"	14.50"	29.50"	12.20"	Weld-on tubular mount with 9/16" pin and foot plate. Male mating mount included.	16.0
1581510117	SWL 158 DTSF w/P&C	2,000	Sidewind	15"	14.50"	29.50"	12.20"	Weld-on tubular mount with 9/16" pin and foot plate. Male mating mount included. Display Box.	16.0
1581090301	N/A	2,000	Sidewind	10"	10.8"	20.8"	6.3"	Weld-on tubular mount	16.6
178101 ♦	TWS 178 DTSF w/P&C	5,000	Topwind	10"	11.25"	21.25"	4.00"	Weld-on tubular mount with 9/16" pin and foot plate. Male mating mount included.	14.5
1781010117	TWS 178 DTSF w/P&C	5,000	Topwind	10"	11.25"	21.25"	4.00"	Weld-on tubular mount with 9/16" pin and foot plate. Male mating mount included. Display Box.	14.5
178151	TWL 178 DTSF w/P&C	5,000	Topwind	15"	14.70"	29.70"	10.00"	Weld-on tubular mount with 9/16" pin and foot plate. Male mating mount included.	18.0
1781510117	TWL 178 DTSF w/P&C	5,000	Topwind	15"	14.70"	29.70"	10.00"	Weld-on tubular mount with 9/16" pin and foot plate. Male mating mount included. Display Box	18.0
178201 ♦	SWS 178 DTSF w/P&C	5,000	Sidewind	10"	10.40"	20.40"	6.40"	Weld-on tubular mount with 5/8" pin and foot plate. Male mating mount included.	15.0
1782010117	SWS 178 DTSF w/P&C	5,000	Sidewind	10"	10.40"	20.40"	6.40"	Weld-on tubular mount with 5/8" pin and foot plate. Male mating mount included. Display Box.	15.0
178203	SWL 178 DTSF w/P&C	5,000	Sidewind	15"	15.40"	30.40"	6.40"	Weld-on tubular mount with 5/8" pin and foot plate. Male mating mount included.	18.0
198100	TWS 198 DTSM w/P&C	7,000	Topwind	10"	10.80"	20.80"	4.50"	Weld-on tubular mount with 5/8" pin and foot plate. Female mating mount included.	17.0
198200	TWL 198 DTSM w/P&C	7,000	Topwind	15"	15.80"	30.80"	4.25"	Weld-on tubular mount with 5/8" pin and foot plate. Female mating mount included.	20.0
198150 ♦	SWS 198 DTSM w/P&C	7,000	Sidewind	10"	11.00"	21.00"	6.40"	Weld-on tubular mount with 5/8" pin and foot plate. Female mating mount included.	19.0
198250	SWL 198 DTSM w/P&C	7,000	Sidewind	15"	16.00"	31.00"	6.40"	Weld-on tubular mount with 5/8" pin and foot plate. Female mating mount included.	21.0

STANDARD ROUND JACKS - A-FRAME

Part No.	Model No.	Lift Cap. (lbs.)	Handle Style	Travel	Measurements			Description	Lbs.
					A Retracted	B Extended	C Clearance		
155022 ♦	TWL 155	2,000	Topwind	15"	8.80"	23.80"	12.20"	Weld-on/bolt-on bracket. Less wheel or base.	12.5
1550220117	TWL 155	2,000	Topwind	15"	8.80"	23.80"	12.20"	Weld-on/bolt-on bracket. Less wheel or base. Display Box.	12.5
155028	TWL 155	2,000	Topwind	15"	8.40"	23.40"	13.00"	Weld-on/bolt-on bracket. Less wheel or base. Clear zinc finish.	12.5
155033	TWL 155X	2,000	Topwind	15"	5.40"	20.40"	16.00"	Weld-on/bolt-on bracket. Less wheel or base.	12.5
155100	N/A	2,000	Topwind	15"	7.5"	22.5"	17"	7.5" Bracket to Ground Retracted, w/Welded Disc Foot	13.4
155157 ♦	SWL 155X (RV)	2,000	Sidewind	13"	8.60"	21.50"	13.00"	External gear box. Handle to front. Weld-on/bolt-on bracket. Less wheel or base.	14.0
1551570117	SWL 155X (RV)	2,000	Sidewind	13"	8.60"	21.50"	13.00"	External gear box. Handle to front. Weld-on/bolt-on bracket. Less wheel or base. Display Box.	14.0
1550100117	SWL 155 X	3,000	Sidewind	13"	7.00"	20.00"	14.50"	External gear box. Weld-on/bolt-on bracket. Less wheel or base. Display Box.	14.0
1550100317	SWL 155 X	3,000	Sidewind	13"	7.00"	20.00"	14.50"	External gear box. Weld-on/bolt-on bracket. Less wheel or base.	14.0
1550101344	SWL 155 X	3,000	Sidewind	13"	7.00"	20.00"	14.50"	External gear box. Weld-on/bolt-on bracket. Less wheel or base. Clear zinc finish.	14.0
155032 ♦	TWL 155 HD	5,000	Topwind	15"	10.30"	25.30"	10.20"	Weld-on/bolt-on bracket. Less wheel or base. (5000 lbs. vertical load capacity)	13.3
1550320117	TWL 155 HD	5,000	Topwind	15"	10.30"	25.30"	10.20"	Weld-on/bolt-on bracket. Less wheel or base. (5000 lbs. vertical load capacity) Display Box.	13.3

(CONTINUED ON NEXT PAGE)

NOTE: Review price list or contact customer service for package quantities and full part number. Other custom-made designs are available upon request.

♦ DENOTES MOST POPULAR

STANDARD ROUND JACKS - A-FRAME

Part No.	Model No.	Lift Cap. (lbs.)	Handle Style	Travel	Measurements			Description	Lbs.
					A Retracted	B Extended	C Clearance		
1750290317 ♦	TWL 175	5,000	Topwind	15"	10.82"	25.82"	10.70"	Weld-on/bolt-on bracket. Less wheel or base.	13.3
1750290301	TWL 175	5,000	Topwind	15"	10.82"	25.82"	10.70"	Weld-on/bolt-on bracket. Less wheel or base. Clear zinc finish.	13.3
1700100117	SWL 175	5,000	Sidewind	15"	8.60"	23.60"	12.75"	Handle to front. Weld-on/bolt-on bracket. Less wheel or base. Display Box.	15.5
1700100317	SWL 175	5,000	Sidewind	15"	8.60"	23.60"	12.75"	Handle to front. Weld-on/bolt-on bracket. Less wheel or base.	15.5
1700100301	SWL 175	5,000	Sidewind	15"	8.60"	23.60"	12.75"	Handle to front. Weld-on/bolt-on bracket. Less wheel or base. Clear zinc finish.	10.2

STANDARD ROUND JACKS - WELD-ON RETAINING RING SWIVEL

Part No.	Model No.	Lift Capacity	Handle Style	Travel	Measurements			Description	Lbs.
					A Retracted	B Extended	C Clearance		
151401 ♦	TWS 151 DS	2,000	Topwind	10"	11.00"	21.00"	4.00"	Weld-on L-bend swivel bracket assembled. 1/2" diameter plunger pin. With footplate.	13.0
1514010117	TWS 151 DS	2,000	Topwind	10"	11.00"	21.00"	4.00"	Weld-on L-bend swivel bracket assembled. 1/2" diameter plunger pin. With footplate. Display Box.	13.0
151421	TWL 151 DS	2,000	Topwind	15"	14.50"	29.50"	10.00"	Weld-on L-bend swivel bracket assembled. 1/2" diameter plunger pin. With footplate.	16.0
1514210117	TWL 151 DS	2,000	Topwind	15"	14.50"	29.50"	10.00"	Weld-on L-bend swivel bracket assembled. 1/2" diameter plunger pin. With footplate. Display Box.	16.0
151460	TWS 151 DS	2,000	Topwind	10"	11.00"	21.00"	4.00"	3/8" diameter plunger pin. With footplate. Clear zinc finish. WELD-ON L-BEND SWIVEL BRACKET SOLD SEPARATELY.	11.4
151101 ♦	SWS 151 DS	2,000	Sidewind	10"	11.00"	21.00"	6.40"	Weld-on L-bend swivel bracket assembled. 1/2" diameter plunger pin. With footplate.	13.0
1511010117	SWS 151 DS	2,000	Sidewind	10"	11.00"	21.00"	6.40"	Weld-on L-bend swivel bracket assembled. 1/2" diameter plunger pin. With footplate. Display Box.	13.0
151159	SWL 151 DS	2,000	Sidewind	15"	14.50"	29.50"	12.20"	Weld-on L-bend swivel bracket assembled. 1/2" diameter plunger pin. With footplate.	17.0
171401	TWS 171 DS	5,000	Topwind	10"	11.25"	21.25"	4.00"	Weld-on L-bend swivel bracket assembled. 1/2" diameter plunger pin. With footplate.	14.0
171412	TWL 171 DS	5,000	Topwind	15"	14.50"	29.50"	10.00"	Weld-on L-bend swivel bracket assembled. 1/2" diameter plunger pin. With footplate.	17.0

STANDARD ROUND JACKS - BOLT-ON RETAINING RING SWIVEL

Part No.	Model No.	Lift Capacity	Handle Style	Travel	Measurements			Description	Lbs.
					A Retracted	B Extended	C Clearance		
151443 ♦	TWS 159 SX	2,000	Topwind	10"	11.00"	21.00"	4.00"	Bolt-on swivel bracket assembled with mounting hardware. 1/2" diameter plunger pin. Without base. Fits tongue up to 3" x 4".	12.25

STANDARD ROUND JACKS - WITHOUT MOUNT

Part No.	Model No.	Lift Capacity	Handle Style	Travel	Measurements			Description	Lbs.
					A Retracted	B Extended	C Clearance		
150152	SWL 150	2,000	Sidewind	15"	26.60"	41.60"	N/A	No foot, no mount, painted outer tube, zinc inner tube.	13.0
150000	TWL 150	2,000	Topwind	10"	15.00"	25.00"	N/A	No foot, no mount, painted outer tube, zinc inner tube.	7.2
1701480317	TWL 170	5,000	Topwind	15"	21.00"	36.00"	N/A	No foot, no mount, painted outer tube, zinc inner tube.	11.45
170205	SWL 170	5,000	Sidewind	15"	19.20"	34.20"	N/A	No foot, no mount, painted outer tube, zinc inner tube.	12.14

NOTE: Review price list or contact Customer Service for package quantities and full part number. Other custom-made designs are available upon request.
 ♦ DENOTES MOST POPULAR



0050240300



500239

ROUND JACK MOUNTING OPTIONS

Part No.	Description	Style
P9222-00	Weld-on retaining ring swivel mount	Weld-on
0050240300	Female tubular swivel mount, 5/8" hole	Weld-on
500239	Male tubular swivel mount, 9/16" hole	Weld-on
0031350300	A-frame bottom support plate	Weld-on



500256



500105 / 500171

ROUND JACK HANDLE OPTIONS

Part No.	Description
500256	Sidewind Crank Kit, Handle, 5-51/64" Radius Assembly & Gear 2,000 lbs. Jacks
500105	Sidewind Crank Assembly for 170's w/Black Knob
500180	Topwind Crank, 6-3/4" Radius w/Red BULLDOG Knob For 750-5,000 lbs. Jacks
500148	Topwind Crank, 9" Radius w/Black "Tear Drop" Knob For 7,000 lbs. Jacks
500171	Sidewind Crank Assembly for 190's, Black



500180



500148



017125



CE555 0301

ROUND JACK WHEEL / FOOT OPTIONS

Part No.	Description
017125	Removable steel caster. Reduces overall jack capacity to 1,000 lbs.
CE555 0101	Removable polyolefin caster. Reduces overall jack capacity to 1,200 lbs. (boxed)
CE555 0301	Removable polyolefin caster. Reduces overall jack capacity to 1,200 lbs. (bulk)
500244	Detachable base, 2.1" height
018098	Detachable base, 6.2" height
500245	Removable 6" caster with pin. Fits jacks with 2" inner tube



500244

TUBE MOUNTS

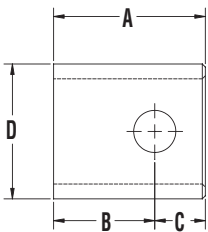

Tube Mount Diagram



0152790300

Part No.	Style	Pin Diameter	Measurements				Fits
			A	B	C	D	
0050050300	Weld-on, male	9/16"	2.25"	1.50"	0.75"	2.00"	2.50"
0152790300	Weld-on, male	5/8"	2.25"	1.50"	0.75"	2.00"	2.50"
0050240300	Weld-on, female	5/8"	2.50"	1.62"	0.88"	3.00"	2.50"
0152730300	Weld-on, male	9/16"	1.88"	1.13"	0.75"	2.00"	2.50"
0152710300	Weld-on, female	9/16"	1.62"	0.88"	0.75"	2.50"	2.00"
0031550300	Weld-on, female	3/4"	3.00"	1.59"	1.41"	3.25"	2.50"
7011800300	Weld-on, male	7/8"	3.31"	1.90"	1.41"	2.50"	3.25"
005122	Weld-on, female	7/8"	2.80"	1.58"	1.22"	4.00"	3.25"
500315	Weld-on, female	5/8"	2.50"	1.50"	1.00"	3.00" sq.	2.50" sq.
PQM19-00	Weld-on, male	5/8"	2.13"	1.25"	0.88"	2.00" sq.	2.50" sq.



ROUND JACKS

- Designed for use with trailers with A-Frame couplers
- Weld-on or Bolt-on mounting option
- A-frame models have black painted outer and inner tubes, all other models have black painted outer and clear zinc inner tubes

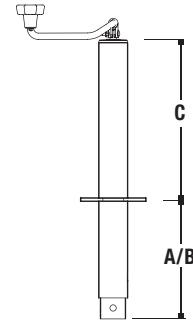

Travel and Clearance
A = Retracted
B = Extended
C = Clearance Height

Actual product may vary slightly from image shown.

STANDARD ROUND JACKS - A-FRAME WITHOUT FOOTPLATE

Part No.	Lift Capacity	Handle Style	Travel	A Retracted	Measurements B Extended	C Clearance	Description	Lbs.
RV20000103	2,000	Sidewind	14"	9.00"	23.00"	13.00"	Front Facing Handle, Boxed	12.00
RV20000303	2,000	Sidewind	14"	9.00"	23.00"	13.00"	Front Facing Handle	12.00
EA20000103	2,000	Topwind	14"	8.00"	22.00"	11.00"	Boxed	11.00
EA20000303	2,000	Topwind	14"	8.00"	22.00"	11.00"		11.00
EA20000340	2,000	Topwind	14"	8.00"	22.00"	11.00"	Clear Zinc Inner & Outer Tubes	11.00
1401000303	2,000	Topwind	15"	5.50"	20.50"	16.00"		12.50
1400600303	5,000	Topwind	15"	10.80"	25.80"	14.55"		13.00

Unless otherwise noted, A-Frame Without Footplate Jacks: 1) Finish is black painted inner and outer tubes 2) Jacks are bulk packed



1400750340



1400700340

STANDARD ROUND JACKS - A-FRAME ACCESSORIES

Part No.	Capacity	Description	Lbs.
1400700340	5,000	Removable Footplate, 2.10" Tall, Fits 2" Inner Tube, Includes Pull Pin Assembly, Clear Zinc Finish	2.50
1400750340	1,200	Removable 6" Caster, Includes Pull Pin Assembly, Clear Zinc Finish	4.00

ROUND JACKS

- Designed for use with recreational and utility trailers
- Bolt-on versions include all necessary mounting hardware
- Weld-on versions include mating mount and retaining ring
- A-frame models have black painted outer and inner tubes, all other models have black painted outer and clear zinc inner tubes

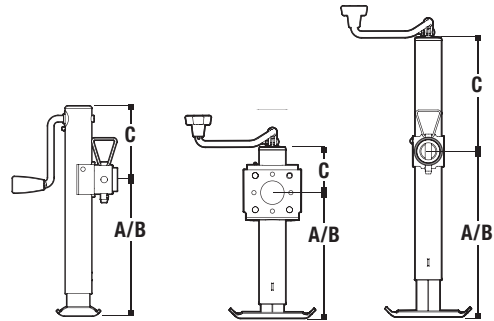

Travel and Clearance
A = Retracted
B = Extended
C = Clearance Height

Actual product may vary slightly from image shown.

STANDARD ROUND JACKS - RETAINING RING SWIVEL, BOLT-ON, WITH FOOTPLATE

Part No.	Lift Capacity	Handle Style	Travel	Measurements			Description	Lbs.
				A Retracted	B Extended	C Clearance		
1400300303	2,000	Topwind	10"	11.00"	21.00"	4.00"	Mounting Hardware Included	14.25

STANDARD ROUND JACKS - RETAINING RING SWIVEL, WELD-ON, WITH FOOTPLATE

Part No.	Lift Capacity	Handle Style	Travel	Measurements			Description	Lbs.
				A Retracted	B Extended	C Clearance		
1401140303	2,000	Topwind	10"	11.00"	21.00"	4.00"	Mating Mount & Retaining Ring Included	11.00
1401040303	2,000	Topwind	15"	14.50"	29.50"	10.00"	Mating Mount & Retaining Ring Included	15.00
1401020303	2,000	Sidewind	10"	10.40"	20.40"	6.29"	Mating Mount & Retaining Ring Included	12.00
1401030303	2,000	Sidewind	15"	14.40"	29.40"	12.25"	Mating Mount & Retaining Ring Included	16.00

STANDARD ROUND JACKS - TUBULAR SWIVEL, WELD-ON, WITH FOOTPLATE

Part No.	Lift Capacity	Handle Style	Travel	Measurements			Description	Lbs.
				A Retracted	B Extended	C Clearance		
1401060303	2,000	Sidewind	10"	11.20"	21.20"	5.45"	Mating Mount & Pull Pin Included	11.50
1401080303	2,000	Sidewind	15"	14.40"	29.40"	12.25"	Mating Mount & Pull Pin Included	15.50
1400400303	2,000	Topwind	10"	11.00"	21.00"	4.00"	Mating Mount & Pull Pin Included	11.00
1401200303	2,000	Topwind	15"	14.50"	29.50"	10.00"	Mating Mount & Pull Pin Included	15.00
1401420303	5,000	Sidewind	10"	10.50"	20.50"	6.25"	Mating Mount & Pull Pin Included	12.00
1401440303	5,000	Sidewind	15"	15.50"	30.50"	6.25"	Mating Mount & Pull Pin Included	15.00
1401460303	5,000	Topwind	10"	11.20"	21.20"	4.00"	Mating Mount & Pull Pin Included	12.50
1401480303	5,000	Topwind	15"	14.70"	29.70"	10.00"	Mating Mount & Pull Pin Included	16.50

Unless otherwise noted, A-Frame Without Footplate Jacks: 1) Finish is black painted inner and outer tubes 2) Jacks are bulk packed



SQUARE JACKS

Square Up for Side Load Strength

Compared to round jacks of similar capacities, BULLDOG's 5,000 lbs. support capacity square jack dramatically improves side load strength while maintaining the economical benefits of lower capacity jacks. The extra side load capacity you need without the costs of increasing overall capacity.

- 12-gauge square tube is 70% stronger than 12-gauge round tube for more side load and support strength with the same lift capacity
- 4.62" outer tube overlap at full extension for additional side load strength
- Weather-resistant materials and coatings. Painted outer tubes, clear zinc inner tubes
- Proven, reliable mechanical elements provide dependable strength and long-lasting, durable performance
- Mounts included in this series of jacks



THE CHOICE WHEN APPLICATION REQUIRES COMPLIANCE WITH ASABE S485 STANDARDS



195356

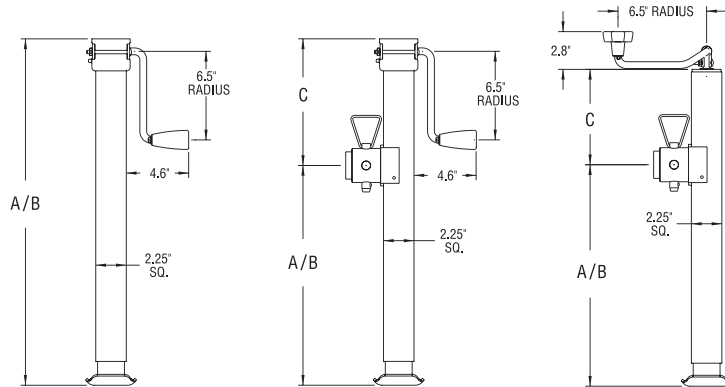

Travel and Clearance Diagram

A= Retracted B= Extended C= Clearance Height



195312



195321



SQUARE JACKS - TUBULAR SWIVEL MOUNT - ROUND

5,000 LBS. SUPPORT CAPACITY - 3,000 LBS. LIFT CAPACITY

Part No.	Model No.	Support Capacity	Handle Style	Travel	Measurements			Description	Lbs.
					A Retracted	B Extended	C Clearance		
195306 ♦	TWL 195 DTSFQ	5,000	Topwind	15"	15.20"	30.20"	7.00"	Fixed leg with base. With tubular swivel mount (includes male mating mount, pin, and chain).	17.5
195356 ♦	SWL 195 DTSFQ w/P&C	5,000	Sidewind	15"	15.10"	30.10"	9.25"	Fixed leg with base. With tubular swivel mount (includes male mating mount, pin, and chain).	18.5

Patent Pending. NOTE: Contact Price List or Customer Service for package quantities and full part number. ♦ DENOTES MOST POPULAR

SQUARE JACKS - TUBULAR SWIVEL MOUNT - SQUARE

5,000 LBS. SUPPORT CAPACITY - 3,000 LBS. LIFT CAPACITY

Part No.	Model No.	Support Capacity	Handle Style	Travel	Measurements			Description	Lbs.
					A Retracted	B Extended	C Clearance		
195312 ♦	TWL 195 DTSXFQ w/P&C	5,000	Topwind	15"	15.20"	30.20"	7.00"	Fixed leg with base. Square mount welded to outer tube (includes male mating mount, pin, and chain).	17.5
195362	SWL 195 DTSXFQ w/P&C	5,000	Sidewind	15"	15.10"	30.10"	9.25"	Fixed leg with base. Square mount welded to outer tube (includes male mating mount, pin, and chain).	18.4

Patent Pending. NOTE: Contact Price List or Customer Service for package quantities and full part number. ♦ DENOTES MOST POPULAR

SQUARE JACKS - A-FRAME

5,000 LBS. SUPPORT CAPACITY - 3,000 LBS. LIFT CAPACITY

Part No.	Model No.	Support Capacity	Handle Style	Travel	Measurements			Description	Lbs.
					A Retracted	B Extended	C Clearance		
195318	TWL 195 DL-DFXQ	5,000	Topwind	15"	7.90"	36.50"	14.70"	Drop leg with base. Drop leg offers 13.50" additional adjustment.	19.3
195321 ♦	TWL 195 FL-FXQ	5,000	Topwind	15"	7.40"	22.40"	14.70"	Fixed leg less base.	13.8

Patent Pending. NOTE: Contact Price List or Customer Service for package quantities and full part number. ♦ DENOTES MOST POPULAR

SQUARE JACKS - DIRECT WELD

5,000 LBS. SUPPORT CAPACITY - 3,000 LBS. LIFT CAPACITY

Part No.	Model No.	Support Capacity	Handle Style	Travel	Measurements			Description	Lbs.
					A Retracted	B Extended	C Clearance		
195301 ♦	TWL 195 DQ	5,000	Topwind	15"	22.20"	37.20"	N/A	Fixed leg with base.	14.1
195304 ♦	TWL 195 DL-DXQ	5,000	Topwind	15"	22.60"	51.20"	N/A	Drop leg with base. Drop leg offers 13.50" additional adjustment.	18.2
195319	TWL 195 FL-BXQ	5,000	Topwind	15"	22.30"	37.30"	N/A	Fixed leg with caster base.	14.1
195320	TWL 195 FL-XQ	5,000	Topwind	15"	22.10"	37.10"	N/A	Fixed leg less base.	12.7
195351	SWL 195 DQ	5,000	Sidewind	10"	17.70"	27.70"	N/A	Fixed leg with base.	12.4
195352	SWL 195 DQ	5,000	Sidewind	15"	24.40"	39.40"	N/A	Fixed leg with base.	16.1
195354 ♦	SWL 195 DL-DXQ	5,000	Sidewind	15"	25.50"	54.10"	N/A	Drop leg with base. Drop leg offers 13.50" additional adjustment.	20.2
195368	SWL 195 FL-XQ	5,000	Sidewind	15"	24.40"	39.40"	N/A	Fixed leg with caster base.	16.1
195369	SWL 195 FL-XQ	5,000	Sidewind	15"	24.20"	39.20"	N/A	Fixed leg less base.	14.7

Patent Pending. NOTE: Contact Price List or Customer Service for package quantities and full part number. ♦ DENOTES MOST POPULAR



SQUARE JACKS

BULLDOG's 8,000 lbs. support capacity square jack serves the agricultural, industrial, construction, horse/livestock trailer, and utility/cargo trailer markets. The compact design of these jacks makes them ideal for tight-fitting applications where 3" and 4" square tube jacks are too big!

- Use the painted outer tube as the final finish or primer
- Zinc-plated inner tube and drop leg
- 4.7" Outer / inner tube overlap - results in optimal side load performance
- 5/8" screw stem - provides insurance against screw stem twisting off
- Patented screw nut stop - prevents screw and/or nut damage when jack is fully extended
- Topwind models - bushing in top cap, eagle claw grip
- Sidewind models - 1/4" cross pin connects gear train to screw stem - guards against shearing jack pin
- Sidewind models - 1:1.33 gear ratio



THE CHOICE WHEN APPLICATION REQUIRES COMPLIANCE WITH ASABE S485 STANDARDS

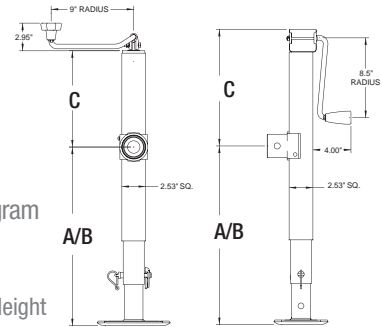

SQUARE JACKS - TUBULAR SWIVEL MOUNT

8,000 LBS. SUPPORT CAPACITY - 5,000 LBS. LIFT CAPACITY

Part No.	Model No.	Support Capacity	Handle Style	Travel	A Retracted	B Extended	C Clearance	Description	Lbs.
190705 ♦	TWS 190 FL-B TSMQ w/P&C	8,000	Topwind	10"	11.41"	21.41"	4.25"	Fixed leg with heavy-duty base. With tubular swivel mount (includes mating mount, pin and chain).	18.0
190706	TWL 190 FL-B TSMQ w/P&C	8,000	Topwind	15"	12.16"	27.16"	10.25"	Fixed leg with heavy-duty base. With tubular swivel mount (includes mating mount, pin and chain).	22.5
190708	TWL 190 DL-B TSMQ w/P&C	8,000	Topwind	15"	12.66"	41.16"	10.25"	Drop leg with heavy-duty base. Drop leg offers 13.50" additional adjustment. With tubular swivel mount (includes mating mount, pin and chain).	27.0
190724	TWL 190 FL-DTS BQ	8,000	Topwind	15"	15.10"	30.10"	7.00"	Fixed leg with heavy-duty base. With tubular swivel mount (includes pin and chain, without mating mount, use 0031550300).	23.0
190756 ♦	SWL 190 FL-B TSMQ w/P&C	8,000	Sidewind	15"	12.16"	27.16"	12.40"	Fixed leg with heavy-duty base. With tubular swivel mount (includes mating mount, pin and chain).	24.0
190758	SWL 190 DL-B TSMQ w/P&C	8,000	Sidewind	15"	12.66"	41.16"	12.40"	Drop leg with heavy-duty base. Drop leg offers 13.50" additional adjustment. With tubular swivel mount (includes mating mount, pin and chain).	28.5
190789	SWL 190 FL-BQ	8,000	Sidewind	15"	15.10"	30.10"	9.40"	Fixed leg with heavy-duty base. With tubular swivel mount (includes pin and chain, without mating mount, use 0031550300).	25.0

SQUARE JACKS - DIRECT WELD

8,000 LBS. SUPPORT CAPACITY - 5,000 LBS. LIFT CAPACITY

Part No.	Model No.	Support Capacity	Handle Style	Travel	A Retracted	B Extended	C Clearance	Description	Lbs.
190704 ♦	TWL 190 DL-BQ	8,000	Topwind	15"	22.66"	51.41"	N/A	Drop leg with heavy-duty base. Drop leg offers 13.50" additional adjustment.	23.5
1907040176	TWL 190 DL-BQ	8,000	Topwind	15"	22.66"	51.41"	N/A	Drop leg with heavy-duty base. Drop leg offers 13.50" additional adjustment. Display Box.	23.5
190754 ♦	SWL 190 DL-BQ	8,000	Sidewind	15"	25.06"	53.56"	N/A	Drop leg with heavy-duty base. Drop leg offers 13.50" additional adjustment.	25.0
1907540176	SWL 190 DL-BQ	8,000	Sidewind	15"	25.06"	53.56"	N/A	Drop leg with heavy-duty base. Drop leg offers 13.50" additional adjustment. Display Box.	25.0

Patent Pending. NOTE: Other custom-made designs are available upon request. ♦ DENOTES MOST POPULAR

SQUARE JACKS

BULLDOG 10,000 lbs. support capacity square jacks “fills the gap” between 8,000 lbs. and 12,000 lbs. square jack product offerings. If the existing 8,000 lbs. support capacity square jacks are too small or the 12,000 lbs. support capacity square jacks are too big, look no further – your application and pricing requirements have been met! This is the highest quality and best performing jack available in the marketplace today, a total balance between capacity, speed, and effort.

- Heavy-gauge 3" square tubing allows for direct weld mounting wherever the application allows – no burn through
- Use the painted outer tube as the final finish or primer
- Zinc-plated inner tube and drop leg
- Heavy-duty base, with reinforcement ribs, zero water retention
- Precision manufactured for long term reliability and smooth, easy cranking
- Grease zerk for easy lubrication as needed
- Oil-impregnated bushing for improved bearing and gear life
- Direct weld to outer tube is standard
- Sidewind models - 1:1.86 gear ratio



THE CHOICE WHEN APPLICATION REQUIRES COMPLIANCE WITH ASABE S485 STANDARDS

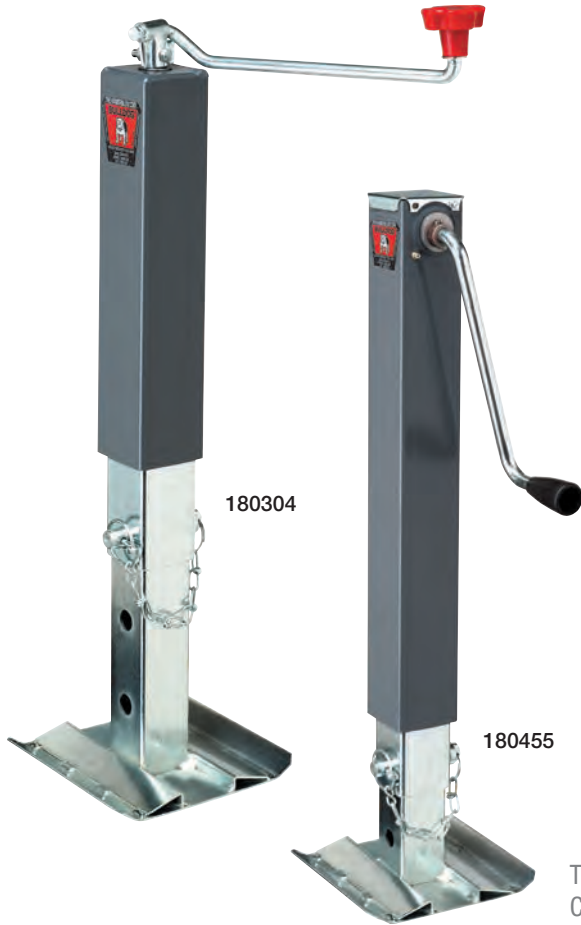

Travel and Clearance Diagram
 A= Retracted
 B= Extended
 C= Clearance Height

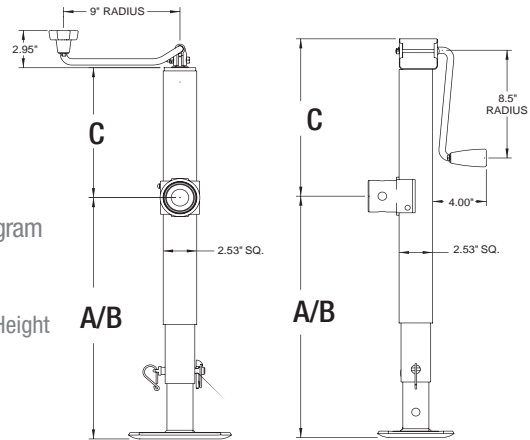

SQUARE JACKS - DIRECT WELD

10,000 LBS. SUPPORT CAPACITY - 7,200 LBS. LIFT CAPACITY

Part No.	Model No.	Support Capacity	Handle Style	Travel	Measurements		Description	Lbs.
					A Retracted	B Extended		
180304	TWS 180 DL-BQ	10,000	Topwind	10"	18.18"	38.31"	Drop leg with heavy-duty base. Drop leg offers 10.12" additional adjustment.	24.5
180354	TWL 180 DL-BQ	10,000	Topwind	15"	22.93"	51.43"	Drop leg with heavy-duty base. Drop leg offers 13.50" additional adjustment.	30.0
180405	SWS 180 DL-BQ	10,000	Sidewind	10"	19.93"	40.05"	Drop leg with heavy-duty base. Drop leg offers 10.12" additional adjustment.	26.2
180455	SWL 180 DL-BQ	10,000	Sidewind	15"	25.67"	54.17"	Drop leg with heavy-duty base. Drop leg offers 13.50" additional adjustment.	32.5

SQUARE JACKS - TUBULAR SWIVEL MOUNT - SQUARE

10,000 LBS. SUPPORT CAPACITY - 7,200 LBS. LIFT CAPACITY



Part No.	Model No.	Support Capacity	Handle Style	Travel	Measurements			Description	Lbs.
					A Retracted	B Extended	C Clearance		
180587	SWL 180 FT-BTSXQ	10,000	Sidewind	15"	12"	27"	12.8"	Fixed leg with base. Square mount welded to outer tube (includes male mating mount, pin, and chain).	15

Patent Pending. NOTE: Contact Price List or Customer Service for package quantities and full part number. Other custom-made designs are available upon request. ♦ DENOTES MOST POPULAR



Pin to Side
182800

Pin to Front
182415

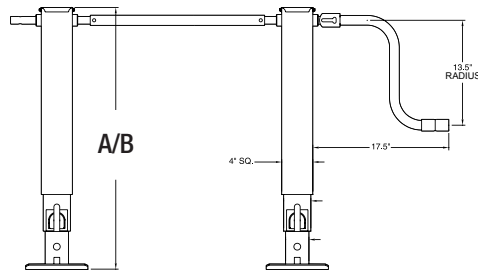

Pin to front tandem application

HEAVY DUTY SQUARE JACKS

Strong, durable, and sturdy, the BULLDOG 12,000 lbs. support capacity square jack is the BIG reason why BULLDOG has carried the load in agricultural, construction, heavy-duty utility, and horse/livestock trailer industries since 1923. All BULLDOG 4" square jacks are rated for 12,000 lbs. support capacity and 10,000 lbs. lift capacity. The strength of the product, plus the wide variety of styles, makes this jack the best choice in its product class.

- 4" square tubing, 7-gauge superior alloy steel
- Painted outer tube, inner tube, and drop leg
- Drop leg option with 5 positioning holes
- Easy-access gear box with grease fitting for routine maintenance
- Spring return drop leg or non-spring return drop leg
- 12.5" screw travel, 13.5" of additional adjustment with drop leg
- Front facing drop leg plunger pin or side facing drop leg plunger pin
- Painted (with or without labels) or powder paint optional
- Sidewind models - 1:1.5 gear ratio

Travel and Clearance Diagram

A= Retracted

B= Extended

C= Clearance Height

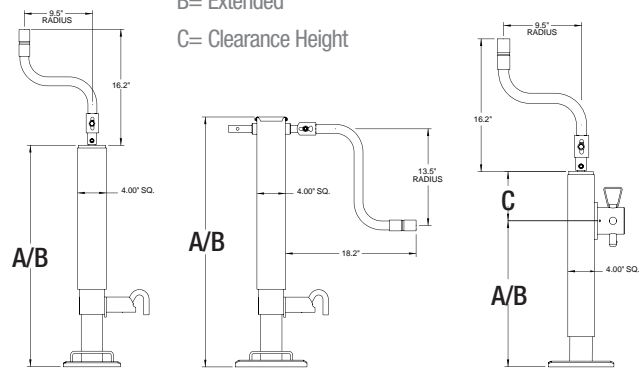

SQUARE JACKS - DIRECT WELD - NON-SPRING RETURN

12,000 LBS. SUPPORT CAPACITY - 10,000 LBS. LIFT CAPACITY

Part No.	Model No.	Support Capacity	Handle Style	Travel	Measurements			Description	Lbs.
					A Retracted	B Extended	C Clearance		
182300	TWQ 180 DL-B	12,000	Topwind	12.5"	23.4"	49.4"	N/A	Drop leg jack with standard disc foot. 13.5" of additional drop leg extension. Crank sold separately.	50.0
182304 ♦	TWQ 180 DL-BC	12,000	Topwind	12.5"	23.4"	49.4"	N/A	Drop leg jack with standard disc foot. 13.5" of additional drop leg extension. Crank included.	53.0
182400 ♦	SWQ 180 DL-B	12,000	Sidewind	12.5"	27.4"	53.3"	N/A	Drop leg jack with standard disc foot. 13.5" of additional drop leg extension. Drop leg pull pin to the SIDE. Crank sold separately.	58.0
182404	SWQ 180 DL-BC	12,000	Sidewind	12.5"	27.4"	53.3"	N/A	Drop leg jack with standard disc foot. 13.5" of additional drop leg extension. Drop leg pull pin to the SIDE. Crank included.	61.5
182411	SWQ 180 DL-B	12,000	Sidewind	12.5"	27.4"	53.5"	N/A	Drop leg jack with standard disc foot. 13.5" of additional drop leg extension. Drop leg pull pin to the SIDE. Crank sold separately. Companion jack to 182400 and 182404.	58.0
182415 ♦	SWQ 180 DL-BX	12,000	Sidewind	12.5"	28.6"	54.6"	N/A	Drop leg jack with standard disc foot. 13.5" of additional dropleg extension. Drop leg pull pin to the FRONT. Crank sold separately.	58.0
182500	SWQ 180 FL-B	12,000	Sidewind	12.5"	27.0"	39.5"	N/A	Fixed leg jack with standard disc foot. Crank sold separately.	47.0

Patent Pending. NOTE: Contact Price List or Customer Service for package quantities and full part number.

Other custom-made designs are available upon request. ♦ DENOTES MOST POPULAR



SQUARE JACKS - DIRECT WELD - SPRING RETURN

12,000 LBS. SUPPORT CAPACITY - 10,000 LBS. LIFT CAPACITY

Part No.	Model No.	Support Capacity	Handle Style	Travel	Measurements			Description	Lbs.
					A Retracted	B Extended	C Clearance		
182800 ♦	SWQ 180 DL-B-SR	12,000	Sidewind	12.5"	27.4"	53.6"	N/A	Drop leg jack with standard disc foot. 13.5" of additional drop leg extension. Drop leg pull pin to the SIDE. Crank sold separately.	57.4
182804	SWQ 180 DL-BC-SR	12,000	Sidewind	12.5"	27.4"	53.6"	N/A	Drop leg jack with standard disc foot. 13.5" of additional drop leg extension. Drop leg pull pin to the SIDE. Includes crank.	60.9
182805	SWQ 180 DL-BX RH	12,000	Sidewind	12.5"	27.4"	53.5"	N/A	Drop leg jack with standard disc foot. 13.5" of additional drop leg extension. Drop leg pull pin to the SIDE. Crank sold separately. Companion jack to 182800, 182802, and 182804	57.4
182815 ♦	SWQ 180 DL-BX	12,000	Sidewind	12.5"	28.6"	54.6"	N/A	Drop leg jack with standard disc foot. 13.5" of additional drop leg extension. Drop leg pull pin to the FRONT. Crank sold separately.	58.0

Patent Pending. NOTE: Contact Price List or Customer Service for package quantities and full part number. Other custom-made designs are available upon request. ♦ DENOTES MOST POPULAR

SQUARE JACKS - TUBULAR SWIVEL - NON-SPRING RETURN

12,000 LBS. SUPPORT CAPACITY - 10,000 LBS. LIFT CAPACITY

Part No.	Model No.	Support Capacity	Handle Style	Travel	Measurements			Description	Lbs.
					A Retracted	B Extended	C Clearance		
182524	SWQ 180 TS-FL-BCX	12,000	Sidewind	12.5"	17.0"	29.6"	10.1"	Fixed leg jack with standard disc foot. Includes crank. Includes 3.25" diameter tube mount with pin and chain. Does not include mating mount (005122).	52.0

Patent Pending. NOTE: Contact Price List or Customer Service for package quantities and full part number. Other custom-made designs are available upon request.



005122
Female Mating Mount
(Purchased separately)



701466

REMOVABLE CRANKS

Part No. 701466

- Non-slotted design for better weather resistance and 2-speed performance
- Remains firmly attached for convenience or may be removed easily for theft deterrence
- Fits 1" schedule 40 steel pipe for remote mounting

ACCESSORIES - 12,000 LBS. SUPPORT CAPACITY JACKS

Part No.	Description	Lbs.
005122	Weld-on female mount for 7/8" pull pin. 4.00" O.D., 3.375" I.D., 2.75" long.	3.0
015181	Sidewind crank assembly with 13.50" radius. Vertical clevis. Mounting hardware included. Extends 17.50" from the jack. Black primed finish.	3.5
800102	Sidewind crank assembly with 13.50" radius. Horizontal clevis. Mounting hardware included. Extends 17.50" from the jack. Black primed finish.	3.5
800075	Topwind crank assembly with 9.50" radius. Vertical clevis. Mounting hardware included. Extends 15.50" from the top of the jack. Black primed finish.	3.0
800090	Sidewind crank assembly with 13.50" radius. Horizontal clevis. Mounting hardware included. Extends 17.50" from the jack. Black primed finish.	4.5
701466	Removable sidewind crank with 13.5" offset radius. All zinc-plated crank. Dual handle grips for cranking and shifting. For use with OEM supplied out-board bushing or may be attached directly on jack gearbox. Needs 012378 adapter with traditional gearbox.	4.0
CS730300	Cross shaft extension tube 72.75" to connect jacks in tandem application	10.0
500312	Handle clip.	0.15



TWIN CAM DROP LEG JACK

The Industry's Strongest Drop Leg Jack.

The BULLDOG® Twin Cam™ features a convenient, enclosed pin mechanism with "twin cam" action that will quickly make this heavy duty, drop leg jack the industry standard.



Twin Cam Drop Leg Mechanism

- The BULLDOG® Twin Cam Drop Leg mechanism allows an increase in the vertical static capacity by using two 3/4" pins to transfer forces between the drop leg and inner tube of the jack.
- The unique Twin Cam drop leg mechanism actuates the drop leg pins in both directions, giving the operator full control over engagement and disengagement of the drop leg pins. The design does not rely on spring pressure alone to keep the pins in the locked position. Patent pending.
- The enclosed Twin Cam drop leg mechanism keeps dirt and debris from interfering with the engagement of the drop leg pins.
- The Twin Cam drop leg mechanism maintains tighter alignment between the drop leg tube and inner tube by having engagement on both sides of the drop leg tube.

Two-Speed Model (also includes)

- Convenient cranking ratios allow for fast operation under a wide range of loading conditions. Drop leg provides quick adjustment.
 - » High speed cranking ratio of 9 turns per inch is convenient for loads up to 12,500 lbs.
 - » Low speed ratio of 29.5 turns per inch allows lifting loads up to 25,000 lbs.

Features

- Easy access grease fittings allow for lubrication of internal jack gears and jack screw/nut.
- Patented screw stop prevents screw and/or nut damage when the jack is fully extended, keeping the screw in good condition for maximum screw/nut cycle life.
- Patented assembly design makes the gears, jack screw/nut, and other internal components easily serviceable. 12.5" of screw travel.
- Drop Leg features 5 positions with 13.5" of adjustment.
- 10" X 10" heavy gauge steel foot plate.
- Heavy duty 1" diameter steel input shaft.
- Spring return and non-spring return drop legs available.

Optional Accessory

- Compatible with BULLDOG® Powered Drive electric motor system (reduces lift capacity to 7,500 lbs).

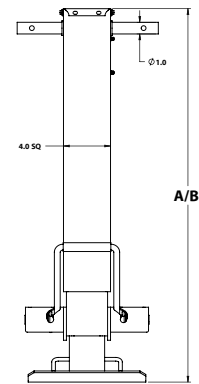

TWIN CAM DROP LEG JACK

Part No.	Handle Style	Screw Travel	Drop Leg Travel	A Retracted	B Extended	Description	Weight
182700	Sidewind	12.5"	13.5"	27.5"	53.5"	Twin Cam Drop Leg – non spring return. Crank sold separately.	62
182701	Sidewind	12.5"	13.5"	28.5"	54.5"	Twin Cam Drop Leg – spring return. Crank sold separately.	63.5
183749	Sidewind Two-speed	12.5"	13.5"	28.5"	54.5"	Twin Cam Drop Leg – non spring return. Crank sold separately.	76
183750	Sidewind Two-speed	12.5"	13.5"	29.5"	55.5"	Twin Cam Drop Leg – spring return. Crank sold separately.	77.5

TWIN CAM DROP LEG CAPACITY

Configurations	Part Number	Static Capacity	Lift Capacity
1 Single-Speed Jack	182700 or 182701	25,000 lbs.	12,500 lbs.
Pair of Single-Speed Jacks in Tandem	(2) 182700 or (2) 182701	50,000 lbs.	12,500 lbs.
1 Two-Speed Jack	183749 or 183750	25,000 lbs.	25,000 lbs.
Two-Speed and Single-Speed Jack in Tandem	182700 & 183749 or 182701 & 183750	50,000 lbs.	45,000 lbs.



Award Winning Design - 2004 ASABE AE50 Award & Wisconsin 2004 Governor's Award

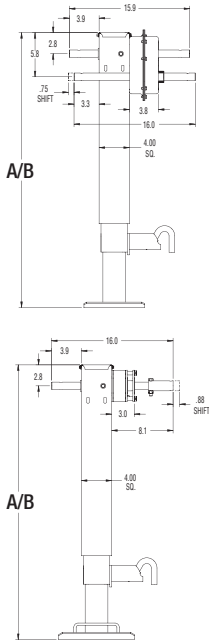

2-SPEED SQUARE JACKS

The First 2-Speed Gearbox Designed with a Drop Leg Jack in Mind.

BULLDOG's 2-speed 12,000 lbs. support capacity square jack makes cranking easier when fully loaded and faster when unloaded. In low gear, the ratio delivers full lifting power at a super-smooth, easy-lifting 27 turns per 1" (planetary) and 29 turns per 1" (traditional) of travel. In high gear, the cranking ratio is a speedy 9 turns per 1" of travel, the fastest in its weight class.

- State of the art 2 speed gearbox with power and speed for the most effective and efficient jack at all loads
- Designed for today's standard agricultural, construction and industrial trailer applications.
- User friendly design makes operation smooth and easy
- Engineered alloys for enhanced strength, stability and sideload capability
- Planetary gearbox fits within the width profile of the jack's outer tube, eliminating the need for spacers

2-SPEED SQUARE JACKS - DIRECT WELD

12,000 LBS. SUPPORT CAPACITY - 10,000 LBS. LIFT CAPACITY

Part No.	Model No.	Support Capacity	Gearbox Style	Travel	Measurements		Description	Companion	Lbs.
					A Retracted	B Extended			
NON-SPRING RETURN									
183401	SWQ 183 DL-BX	12,000	Planetary	12.5"	28.5"	54.6"	2-Speed, drop leg with standard disc foot. 13.50" additional drop leg extension. Drop leg pull pin to the SIDE. Painted outer tube, inner tube, and drop leg. Crank sold separately.	182411	67.0
183416	SWQ 183 DL-BX	12,000	Planetary	12.5"	29.5"	55.6"	2-Speed, drop leg with standard disc foot. 13.50" additional drop leg extension. Drop leg pull pin to the FRONT. Painted outer tube, inner tube, and drop leg. Crank sold separately.	182415	67.0
183900	SWQ 180 DL-B	12,000	Traditional	12.5"	28.5"	54.6"	2-Speed, drop leg with standard disc foot. 13.50" additional drop leg extension. Drop leg pull pin to the SIDE. Painted outer tube, inner tube, and drop leg. Crank sold separately.	182411	77.0
183901	SWQ 180 DL-BX T	12,000	Traditional	12.5"	29.5"	55.6"	2-Speed, drop leg with standard disc foot. 13.50" additional drop leg extension. Drop leg pull pin to the FRONT. Painted outer tube, inner tube, and drop leg. Crank sold separately.	182415	77.0
SPRING RETURN									
183816	SWQ 183 DL-BX w/SR	12,000	Planetary	12.5"	29.5"	55.6"	2-Speed, drop leg with standard disc foot. 13.50" additional drop leg extension. Drop leg pull pin to the FRONT. Painted outer tube, inner tube, and drop leg. Crank sold separately.	182815	65.0
183902	SWQ 180 DL-B w/SR T	12,000	Traditional	12.5"	28.5"	54.6"	2-Speed, drop leg with standard disc foot. 13.50" additional drop leg extension. Drop leg pull pin to the SIDE. Painted outer tube, inner tube, and drop leg. Crank sold separately.	182805	77.0
183903	SWQ 180 DL-BX w/SR T	12,000	Traditional	12.5"	29.5"	55.6"	2-Speed, drop leg with standard disc foot. 13.50" additional drop leg extension. Drop leg pull pin to the FRONT. Painted outer tube, inner tube, and drop leg. Crank sold separately.	182815	77.0
REPLACEMENT PART									
500285	Planetary 2-speed sun gear kit.								
500295	Traditional 2-speed gear kit.								
500330	Planetary gearbox kit.								

NOTE: Contact Price List or Customer Service for package quantities and full part number.



POWERED DRIVE KITS

Designed for use with BULLDOG 12,000 lbs. and Twin Cam jacks.

Lifts 50% more than competition

- Lifts 3" per minute at typical working loads
- Can be manually cranked in the event of power loss

State of the art 12VDC electric motor

- Quiet operation - 50% quieter than competitive units
- Efficient use of electrical power - 60% more efficient than competitive units
- Permanently lubricated to provide years of maintenance free use

Custom designed wiring harness & rocker switch enclosed in a weather proof box

- Utilizes a 25 amp circuit breaker with push button reset feature

Can be used in both single & tandem jack applications Kit includes all necessary components for ease of installation

- Powered drive assembly
- Torque stop tube with energy absorption device
- Terminal box, wiring harness & switch box
- Hex coupling (not shown, required when using in a tandem jack application)
- Weather resistant cover (not shown)



POWERED DRIVE KITS

Part No.	Lift Capacity	Description	Lbs.
1824200100	7,500 lbs.	Electric Powered Kit	20.5
1824180100	7,500 lbs.	Electric Powered Kit - Only Compatible with 2-Speed Square BULLDOG Planetary Jacks	19.75

REPLACEMENT PARTS	
500370	Replacement Part, Powered Single Speed Drive Motor for 1824200100 Only

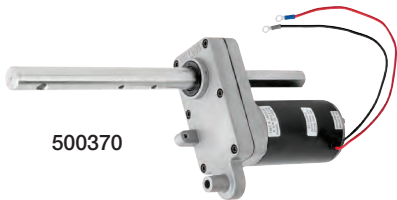

500370



SQUARE JACKS

Square Up for Side Load Strength

- Square jack dramatically improves side load strength
- Drop leg and fixed leg models available
- Tubular swivel models include mating mount and pull pin

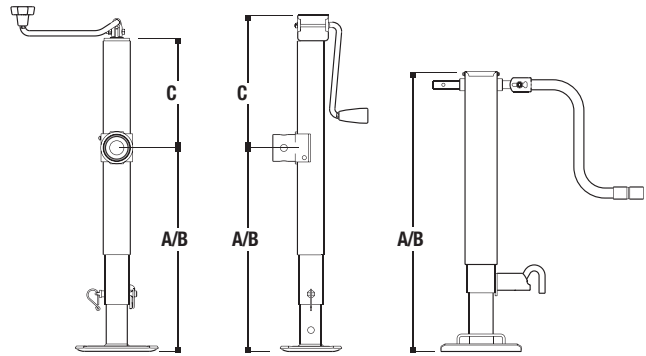

Travel and Clearance

A = Retracted B = Extended C = Clearance Height

Actual product may vary slightly from image shown.

SQUARE JACKS - WELD-ON - TUBULAR SWIVEL

Part No.	Support Capacity	Handle Style	Travel	A Retracted	B Extended	C Clearance	Description	Lbs.
1401520383	5,000	Topwind	10"	17.20"	27.20"	5.00"	Finish is black painted outer tube, clear zinc inner tube. Fixed leg.	17.00
1401610383	5,000	Sidewind	10"	17.40"	27.40"	8.00"	Finish is black painted outer tube, clear zinc inner tube. Fixed leg.	18.00
1400830383	8,000	Topwind	10"	17.20"	27.20"	5.00"	Finish is black painted outer tube, clear zinc inner tube. Fixed leg.	17.00
1400860383	8,000	Sidewind	10"	17.10"	27.10"	7.30"	Finish is black painted outer tube, clear zinc inner tube. Fixed leg.	18.00

SQUARE JACKS - DIRECT WELD

Part No.	Support Capacity	Handle Style	Travel	A Retracted	B Extended	C Clearance	Description	Lbs.
1401500383	5,000	Topwind	15"	22.60"	51.20"	N/A	Finish is black painted outer tube, clear zinc inner tube and 28" travel with drop leg.	20.00
1401600383	5,000	Sidewind	15"	25.80"	54.40"	N/A	Finish is black painted outer tube, clear zinc inner tube and 28" travel with drop leg.	21.00
1400800383	8,000	Topwind	15"	22.90"	51.50"	N/A	Finish is black painted outer and inner tube and 28" travel with drop leg.	20.00
1400850383	8,000	Sidewind	15"	25.20"	53.80"	N/A	Finish is black painted outer and inner tube and 28" travel with drop leg.	21.00
140094	12,000	Sidewind	12.5"	27.25"	53.25"	N/A	Spring return drop leg, 26" travel with drop leg, pin to side, crank included. Finish is black painted outer tube, inner tube, and drop leg.	62.00
1400950376	12,000	Sidewind	12.5"	28.25"	54.25"	N/A	Spring return drop leg, 26" travel with drop leg, pin to front, crank included. Finish is black painted outer tube, inner tube, and drop leg.	62.00
1400960376	12,000	Sidewind	12.5"	28.25"	54.25"	N/A	Spring return drop leg, 26" travel with drop leg, pin to front. Finish is black painted outer tube, inner tube, and drop leg.	59.00
1400980376	12,000	Sidewind	12.5"	28.25"	54.25"	N/A	Non spring return drop leg, 26" travel with drop leg, pin to front, crank included. Finish is black painted outer tube, inner tube, and drop leg.	61.00
1400990376	12,000	Sidewind	12.5"	28.25"	54.25"	N/A	Non spring return drop leg, 26" travel with drop leg, pin to front. Finish is black painted outer tube, inner tube, and drop leg.	58.00
1401010376	12,000	Sidewind	12.5"	28.25"	54.25"	N/A	Non spring return drop leg, 26" travel with drop leg, pin to side, crank included. Finish is black painted outer tube, inner tube, and drop leg.	61.00

ACCESSORY PART

Part No.	Description
1400920383	12K Crank, Mounting Hardware & Clip, Black Painted Finish



VELOCITY SERIES™ HIGH SPEED JACKS

- OEM and Aftermarket Industrial, Horse & Livestock, and RV Applications
- Mounts without welding and requires no hydraulic oil, hoses, or pumps
- Fully Powered – 12,000 lbs. capacity per leg with Proprietary high-speed system
- 24" of travel
- Includes wired remote
- Resists corrosion with premium powder coat finish
- Optional wireless controller available (P/N 500527)
- Manual override in case of power loss
- 5 year limited warranty



VELOCITY SERIES™ HIGH SPEED JACKS

Part No.	Capacity (TW/GTW)	Description	Lbs.
185400	12,000 lbs.	Velocity Series™ High Speed Jack (includes single remote)	102.00
185402	12,000 lbs.	Velocity Series™ High Speed Jack (less remote)	102.00

REPLACEMENT PARTS

Part No.	Description
500374	Replacement Part, Foot Plate for Velocity Series™
500375	Replacement Part, Cover Kit for Velocity Series™
500376	Replacement Part, Contactor Kit for Velocity Series™

ACCESSORIES

Part No.	Description
500527	Jack Accessory, Wireless controller, 3-pin
500372	Jack Accessory, Velocity Series™ High Speed Jack Single Remote
500379	Jack Accessory, Velocity Series™ High Speed Jack Tandem Remote
500380	Jack Accessory, Velocity Series™ High Speed Jack 3 Pin Connector
500382	Jack Accessory, Velocity Series™ High Speed Jack Channel Adapter Kit
500386	Jack Accessory, Velocity Series™ High Speed Jack Single Remote



500527



500382
(hardware included, but no shown)



500380



500372



500379



500386



Shown with standard TTMA mount, mounted to outside of frame



HEAVY DUTY 2-SPEED TANDEM LANDING GEAR

- AAR & TTMA rated (all values per pair): 45,000 lbs. lifting capacity (@ 100 ft. lbs. input torque), 90,000 lbs. static capacity
- Competitive Cranking ratios: Low speed gear 27.3 turns per inch, High speed gear 4.5 turns per inch
- 17" of Travel
- High efficiency, double lead screw
- Heavy duty, self-leveling sand shoe
- Crank included – cross shaft sold separately
- Black painted finish
- 5 year limited warranty



Ideal for horse, livestock and heavy duty trailers

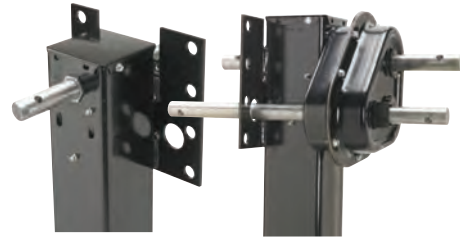

Easy-access grease fittings

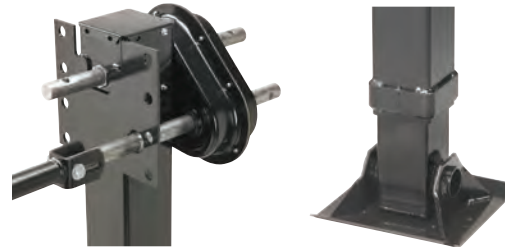

Shown with standard TTMA mount, mounted to inside of frame

Heavy duty leg band for added strength. Sand shoe designed to maximize connection strength.

HEAVY DUTY 2-SPEED TANDEM LANDING GEAR

90,000 LBS. SUPPORT CAPACITY - 45,000 LBS. LIFT CAPACITY

Part No.	Support Capacity	Description	Measurements		
			Travel	A Retracted	B Extended
500153	90,000	Tandem Non Drop Leg Landing Gear - Set includes Direct Weld 2-Speed & Single Speed Jacks & Crank. Cross Shaft not included.	17"	31.7"	48.7"
500154	90,000	Tandem Non Drop Leg Landing Gear - Set includes TTMA Bolt-On Mount 2-Speed & Single Speed Jacks & Crank. Cross Shaft not included.	17"	31.7"	48.7"
1839050383		2-Speed Jack, Direct Weld. Crank sold separately.	17"	31.7"	48.7"
1839060383		2-Speed Jack, TTMA Bolt-On Mount. Crank sold separately.	17"	31.7"	48.7"
1823050383		Single Speed Jack, Direct Weld. Crank sold separately.	17"	31.7"	48.7"
1823060383		Single Speed Jack, TTMA Bolt-On Mount. Crank sold separately.	17"	31.7"	48.7"

ACCESSORY PARTS

8001090283	Crank, Mounting hardware included.
CS730300	72.75" Cross Shaft, Slotted Ends, Hardware Included
500293	Tandem Landing Gear Jack 90K Screw & Nut Assembly (1), Retaining Pins (2), Washer (1), Bearing Bushing (1) & Thrust Bearing (1)
500294	Tandem Landing Gear Jack 90K Gear Assembly Includes: Grooved Pin (1), Spring (1), Chrome Steel Ball (1), Spur Gear 32T, Intermediate Spur Gear 32T/13T (1), Input Spur Gear 32T/13T (1), Woodruff Key (1) & 2-Speed Gearbox Gasket (1)

FIFTH WHEEL LANDING GEAR SYSTEM



FIFTH WHEEL LANDING GEAR SYSTEM



- Traditional Single Drive System
- Heavy gauge 6" x 8" self-leveling footplates with drain holes to prevent corrosion
- Spring loaded drop leg pin on 8000 lbs. support capacity model
- Includes secondary gearbox
- 36" total travel
- Includes adjustable cross shaft
- Includes 4 mounting brackets and 4 sets of mounting hardware
- Motor, switch and harness must be obtained separately
- 5 year limited warranty



FIFTH WHEEL LANDING GEAR SYSTEM

Part No.	Support Capacity	Lift Capacity	Description	Measurements	
				Total Lift	Screw Travel
500162	8,000	4,000	RV Landing Gear Assembly (Motor, Switch and Harness Must Be Obtained Separately)	36"	18"

REPLACEMENT PART

Part No.	Description
500359	Dual Output Motor for 500161
500368	Replacement Part, Control Switch for 500161, 500162



#500161 only – shown with motor assembled in alternate position

DUAL OUTPUT POWERED DRIVE FIFTH WHEEL LANDING GEAR SYSTEM

- Dual Output Powered Drives
- High speed position installation results in lifting speeds of 9"/minute
- Heavy duty integrated die-cast gearbox eliminates the need for an intermediate plastic gear box
- Spring loaded drop leg pin
- Independent leg control for leveling
- Heavy gauge 6" x 8" self-leveling footplates
- 36" total travel
- Includes motors preassembled to jacks
- Includes dual switch panel and wiring harness
- Includes 4 mounting brackets and 4 sets of mounting hardware
- 5 year limited warranty



DUAL OUTPUT POWERED DRIVE FIFTH WHEEL LANDING GEAR SYSTEM

10,000 LBS. SUPPORT CAPACITY

Part No.	Support Capacity	Lift Capacity	Description	Motor & Switches	Measurements	
					Total Lift	Screw Travel
500161	10,000	7,000	RV Landing Gear Assembly	2	36"	18"

REPLACEMENT PART

Part No.	Description
500359	Dual Output Motor for 500161 & 500170
500367	Replacement Part, Drop Leg and Foot Plate for 500161 & 500170



RACK / GEAR JACKS

750 lbs. A-Frame & BOLT-ON

BULLDOG experience and engineering know-how have produced a line of rack and gear jacks that are tough and trusted, the most preferred jacks used by trailer manufacturers in a variety of industries.

- Smooth-cranking 4 turns per inch of travel
- Strong, durable design
- All-welded steel gear box
- Proven reliability for long term use at rated loads
- Weather-resistant clear zinc-plated rack post
- Gray primer-painted steel wheel and gear box
- Custom designs available



1,200 lbs. Heavy-Duty

These heavy-duty rack jacks exemplify BULLDOG's reputation for strength, providing additional lift capacity to a full 1,200 pounds. Specially designed and manufactured to BULLDOG's unparalleled standards, they are ideal for heavier trailers and greater tongue weights.

- Smooth-cranking 4 turns per inch of travel
- Powerful heavy-duty gear box
- Special steel alloy helical gear for extra lift capacity
- Extra heavy-duty gauge post for maximum side load strength
- Specially designed gusseted caster bracket for increased stability
- Superior extension capabilities (up to 26.5" on the HD165WX model, the highest in the industry and ideal for use with big 4x4 trucks)
- Weather-resistant yellow zinc-plated rack post
- Red oxide primer-painted steel wheel and gear box
- Custom designs available

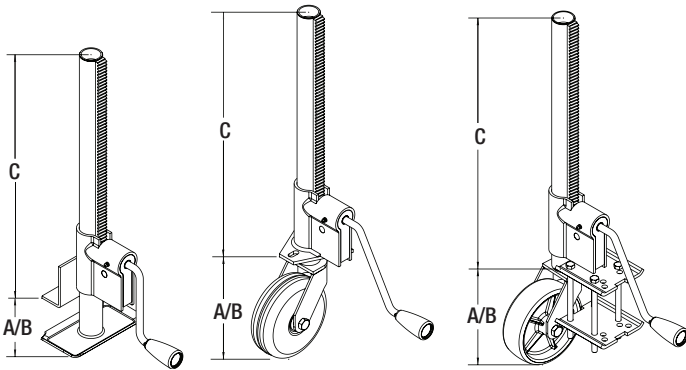

Travel and Clearance Diagram
A= Retracted B= Extended C= Clearance Height

MOUNTING OPTIONS

L-BEND BRACKET WELD-ON

Welds to side and bottom of tongue



161 Series

L-BEND BRACKET BOLT-ON

Fits up to 4" square tongue



162 Series

A-FRAME

Welds or bolts to top of A-frame coupler



165 Series

BOLT-ON

Fits up to 3" x 5" rectangular tongue



169 Series

WHEEL / FOOT OPTIONS

CASTER WHEELS

Polyolefin Wheel
750 lbs. capacity



"R" Models

STEEL WHEEL

750 lbs. capacity
1,200 lbs. capacity - heavy-duty



"W" Models

DISC FOOT

Welded to Jack Post
750 lbs. capacity



"D" Models



STANDARD RACK / GEAR JACKS - L-BEND WELD-ON – 161 SERIES

Part No.	Model No.	Lift Capacity	Includes		Travel	Measurements			Description	Lbs.
			*Gear Box	*Rack Post		A Retracted	B Extended	C Clearance		
161300 ♦	161 W	750	0181610317	0180060301	16"	6.5"	22.5"	21.2"	Weld-on L-bend bracket, with steel wheel.	13.7

STANDARD RACK / GEAR JACKS - L-BEND BOLT-ON – 162 SERIES

Part No.	Model No.	Lift Capacity	Includes		Travel	Measurements			Description	Lbs.
			*Gear Box	*Rack Post		A Retracted	B Extended	C Clearance		
162300 ♦	162 W	750	019032	0180060301	16"	6.0"	22.0"	21.8"	Bolt-on L-bend bracket, with steel wheel.	16.7

STANDARD RACK / GEAR JACKS - A-FRAME – 165 SERIES

Part No.	Model No.	Lift Capacity	Includes		Travel	Measurements			Description	Lbs.
			*Gear Box	*Rack Post		A Retracted	B Extended	C Clearance		
165111 ♦	165 D	750	0181550317	0185200301	16"	3.5"	19.5"	20.2"	A-frame weld-on/bolt-on bracket, with disc foot.	11.1
165211	165 R	750	0181550317	0180070301	16"	7.5"	23.5"	20.3"	A-frame weld-on/bolt-on bracket, with polyolefin wheel.	12.3
165311 ♦	165 W	750	0181550317	0180060301	16"	7.5"	23.5"	20.3"	A-frame weld-on/bolt-on bracket, with steel wheel.	13.4
165411 ♦	HD 165 W	1,200	0191410310	0190600324	16"	7.5"	23.5"	20.3"	Heavy-duty A-frame weld-on/bolt-on bracket, with heavy-duty 21" long 1,200 pound rack and post, with steel wheel.	14.4
165412	HD 165 WX	1,200	0191410310	0190800324	19"	7.5"	26.5"	23.3"	Heavy-duty A-frame weld-on/bolt-on bracket, with heavy-duty 24" long 1,200 pound rack and post, with steel wheel.	15.1

STANDARD RACK / GEAR JACKS - RECTANGULAR BOLT-ON – 169 SERIES

Part No.	Model No.	Lift Capacity	Includes		Travel	Measurements			Description	Lbs.
			*Gear Box	*Rack Post		A Retracted	B Extended	C Clearance		
169201 ♦	169 RB	750	0181910378	0183080301	16"	7.5"	23.5"	20.3"	Bolt-on mount, fits up to 3" x 5" tongue, with mounting kit and polyolefin wheel, black finish.	14.9

*Gear boxes and rack post also sold separately. ♦ DENOTES MOST POPULAR

NOTE: Contact Price List or Customer Service for package quantities and full part number. Other custom-made designs are available upon request.



0917501S00

CE555 0101



CP555 0301

500245



017125

018507



CA5550301



500326



0031350300

WHEELS

Part No.	Description	Pkg.
POLY WHEELS		
0917501S00	6" poly wheel only – 750 - 1,200 lbs. rated	Bulk
CE555 0101	6" caster with 2" inside diameter fitting for 2" jack tube – 1,200 lbs. rated	Boxed
CE555 0301	6" caster with 2" inside diameter fitting for 2" jack tube – 1,200 lbs. rated	Bulk
500245	6" caster with pin 2" inside diameter fitting for 2" jack tube - 1,200 lbs. rated	Clam
HEAVY-DUTY PHENOLIC WHEELS		
CP555 0301	6" caster with 2" inside diameter fitting for 2" jack tube – 1,500 lbs. rated	Bulk
STEEL WHEELS (REDUCES RATED CAPACITIES OF ANY JACK)		
017125	Caster assembly w/6" steel wheel, fits 2" inner tube – 750 - 1,000 lbs. rated	Bulk
018507	Caster assembly w/6" steel wheel for 155159 and 155300 – 1,000 lbs. rated	Poly Bag

CASTER ADAPTER PLATES

Part No.	Description	Pkg.
CASTER ADAPTER PLATES		
CA5550301	Caster adapter plate	Bulk

JACK CAP

Part No.	Description	Pkg.
JACK CAP		
500326	2K sidewind jack cap	Bulk

BOTTOM SUPPORT PLATES

Part No.	Description	Pkg.
BOTTOM SUPPORT PLATES		
0031350300	A-frame support plate, forged coupler.	Bulk
SPB50 0300	Bottom support plate with 2.29" diameter hole, cast and stamped couplers.	Bulk
SPBQ500300	Bottom support plate with 2.3" square hole	Bulk



FP20000201



500244

REMOVABLE FOOTPLATES

Part No.	Description	Pkg.
REMOVABLE FOOTPLATES		
0185640301	Removable footplate w/pin. 2.1" tall, fits 2" inner tube, 2,000-5,000 lbs. rated	Bulk
0181730324	Removable footplate 6.2"	Bulk
018098	Removable footplate w/pin. 6.2" tall, fits 2" inner tube, 2,000-5,000 lbs. rated	Bulk
FP20000201	Foot with hardware (bolt goes through 2" jack tube holes) – 2,000 lbs. rated	Poly Bag
500244	Removable footplate with pin. Fits Jacks with 2" inner tube. (2.1" tall)	Clam
F3500 0324	Removable footplate with pin. Fits Jacks with 2" SQUARE inner tube. (4.0" tall)	Bulk
F2000 0101	Footpad for 2,000/5,000 lbs. Jacks	Boxed
F2000 0301	Footpad for 2,000/5,000 lbs. Jacks	Bulk

DROP LEGS



DF35000324



500190

Part No.	Description	Pkg.
DROP LEGS		
DF35000324	For square jack, 1.71" square tube, pin included – 3,000 - 5,000 lbs. rated	Bulk
500190	For most 2,000 lbs. BULLDOG round jacks & BULLDOG powered A-Frame jacks. Pin included, 5,000 lbs. rated. Will not work with Pro Series round jacks & BULLDOG round jacks with heavy wall inner tubes.	Ind. Box
500270	For square jack, 2.0" square tube, pin included – 8,000 lbs. rated	Bulk
500329	Drop Leg & Pin	Bulk
500340	Replacement Part, Drop Leg Pull Pin Assembly, 7/8" x 2.25"	Bulk
500377	Drop Leg & Pin	4 per Master Carton

PINS



500103



500177



500178



500243

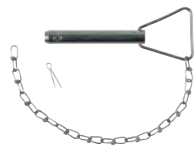

500232



500231

Part No.	Description	Pkg.
PINS		
500103	3/8" plunger pin assembly. (BULLDOG only)	Poly Bag
500310	3/4" pull pin (4.75" long) with chain without drive screw – 7,000 lbs.	Bulk
500341	Replacement Part, 7/8" Pin & Chain w/o Drive Screw	Boxed
PIN KITS		
500177	3/4" drop-leg plunger pin kit SERIES: 180	
500178	1/2" plunger pin assembly kit. SERIES: 150, 160, 170	Clam
500231	5/8" pull pin 3.5" long, with chain, and drive screw. (5,000 lbs. - Sidewind only) SERIES: Sidewind-170, Crown 2,000/3,000/5,000 lbs.	Clam
500232	5/8" pull pin, 4.25" long, with chain, and cotter pin. SERIES: 190, Crown 7,000 lbs.	Clam
500243	9/16" pull pin 3.5" long with chain and drive screw. (5,000 lbs. - Topwind only) SERIES: 150, Topwind-170	Clam
DROP LEG PINS		
500337	Replacement Part, Drop Leg Pull Pin Assembly, 3/4" x 3"	Poly Bag
500338	Replacement Part, Drop Leg Pull Pin Assembly, 9/16" x 2.75"	Poly Bag
500340	Replacement Part, Drop Leg Pull Pin Assembly, 7/8" x 2.25"	Bulk
0252010201	5/16" snapper pin, with chain	Bulk
LYNCH PIN KIT		
500219	Lynch pin kit, 0.563" diameter	Poly Bag



500239



500238

500240



500242

500315



500148



800075



500180

MOUNTS

Part No.	Description	Pkg.
MOUNTS		
500239	Trailer mount, male, weld-on, for 9/16" pin. (5,000 lbs. - Topwind only) SERIES: 150, Topwind-170	Clam
500238	Trailer mount, female, weld-on, for 5/8" pin, 3" O.D.	Clam
500240	Trailer mount, male, weld-on, for 5/8" pin, 2" O.D.	Clam
RETAINING RING MOUNTING BRACKETS		
P20520-00	Weld-on flat, retaining ring swivel plate for 3/8" diameter plunger pin.	Bulk
P9222-00	Weld-on, swivel bracket, 1/2" pin - 2,000 - 5,000 lbs. rated	Bulk
500242	Weld-on, swivel bracket, 1/2" pin - 2,000 - 5,000 lbs. rated	Clam
SWIVEL TRAILER MOUNT		
500315	Swivel trailer mount, tubular male weld-on for 5/8" pull pin. SERIES: 150, 170, 190.	Bulk
500339	Jack Accessory, Swivel Trailer Mount, Round Tube Male Weld-On U-Bracket for 5/8" Pull Pin	Poly Bag

TOPWIND CRANKS

Part No.	Description	Pkg.
TOPWIND CRANKS		
500180	Topwind crank (6.75" radius) assembly with red knob. SERIES: Topwind-150, 160, 170. 2,000 - 5,000 lbs.	Clam
500148	Topwind crank (9.00" radius) assembly with black knob. SERIES: Topwind-190 7,000 lbs. 7,000 / 8,000 lbs.	Clam
500344	Replacement Part, 12" Topwind Handle for 10K Square Jack	Ind. Box
800075	Topwind crank 1" tubing (9.50" radius) - 12,000 lbs. square	Bulk

SIDEWIND CRANKS

Part No.	Description	Pkg.
SIDEWIND CRANKS		
500256	Sidewind crank (5.80" radius) assembly and gear kit. SERIES: 150 with plastic cap. 2000 lbs.	Clam
500105	Sidewind crank (6.50" radius) assembly with black knob. SERIES: 139, 159, 170, Crown 2,000/3,000/5,000 lbs.	Clam
500171	Sidewind crank (8.50" radius) assembly with black knob. SERIES: 190 square jacks, Crown 7,000 lbs. 7,000 / 8,000 lbs.	Clam
015181	Sidewind crank, vertical clevis (13.50" radius), black primed finish, hardware included	Bulk
800102	Sidewind crank assembly with 13.50" radius. Mounting hardware not included. Extends 17.50" from the jack. Black primed finish. Horizontal clevis, Sidewind handle.	Bulk
701466	Removable sidewind crank with 13.5" offset radius. All zinc-plated crank. Dual handle grips for cranking and shifting. For use with OEM supplied outboard bushing or may be attached directly on jack gearbox.	Bulk
800090	Sidewind crank, horizontal clevis (13.50" radius), black primed finish, hardware include.	Bulk
8001090283	Sidewind crank assembly with 13.50" radius, mounting hardware included, extends 20" from the jack, black prime finish, vertical clevis.	Bulk
500312	Handle clip.	Bulk
800148	Sidewind crank, 13.5" radius w/soft touch handle grip for 12,000 lbs. jacks. w/ 13/16" hex socket.	Bulk
HDDS 0201	Shaft handle, hex drive - zinc for 800148	Bulk



500256



500105

500171

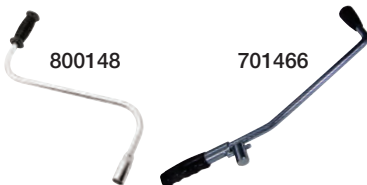

800148

701466



500106



500156



500212



500251



500248



500246

ASSEMBLY KITS

Part No.	Description	Pkg.
BEARING KITS		
500251	Bearing kit. For 2,000 lbs. capacity models. SERIES: 150	Clam
500223	Thrust bearing. For 5,000 lbs. capacity models. SERIES: 170, Crown 5,000 lbs.	Clam
500224	Thrust bearing. For 8,000 lbs. capacity models. SERIES: 190, Crown 7,000 lbs.	Clam
GEAR KITS		
500106	Sidewind gear kit. For up to and including 5,000 lbs. capacity models. SERIES: 139, 159, 170 Crown 2,000/3,000/5,000 lbs.	Clam
500156	Sidewind gear kit. For 8,000 lbs. capacity models. SERIES: 190, Crown 7,000 lbs. with 1/2" inside bottom gear	Clam
5002581360	Sidewind gear kit. SERIES: 190 Crown 7,000 lbs. with 5/8" I.D. bottom gear	Poly Bag
800144	Service kit containing the sidewind crank (10.50"), bearing, gears, pins and bushings for 10,000 lbs. capacity 180 SERIES sidewind jacks	Poly Bag
500285	Sun gear and stub shaft assembly and bushings for 12,000 lbs. capacity two speed planetary gear box	Poly Bag
500212	Gear kit including, pins and bushing – 12,000 lbs.	Poly Bag
RETAINING RING KITS		
500241	Swivel retaining ring. Fits most jack capacities. SERIES: 150, 160, 170	Clam
P9086-00	Swivel retaining ring. Fits most jack capacities. SERIES: 150, 160, 170	Bulk
ASSEMBLY KIT		
500217	Screw and nut assembly, bearing, support washer and retaining pins for 12,000 lbs. capacity BULLDOG® sidewind jacks	Poly Bag
500250	Screw and nut assembly, bearing, support washer and retaining pins for 12,000 lbs. capacity BULLDOG® topwind jacks	Poly Bag
GEAR BOX COVER		
500205	Gear box cover for 3,000 - 8,000 lbs. capacity sidewind jacks, includes hardware	Poly Bag



500223



500224



500241

KNOBS

Part No.	Description	Pkg.
KNOBS		
500248	Black knob, teardrop. SERIES: 139, 159, Sidewind-170, 90, Crown. 2,000 - 5,000 lbs.	Clam
500246	Red knob, BULLDOG. SERIES: 150, 160, Topwind-170. 2,000 - 5,000 lbs.	Clam



F2® MARINE AND RECREATIONAL JACKS

Fulton, the industry leader for high performance marine jacks, is proud to introduce a revolution in trailer jack engineering. The F2®, designed for use with marine, recreational and utility trailers, continues the Fulton heritage of innovation rethinking every feature and challenging industry conventions. The result is a reengineered high quality product that will transform the industry. It's so strong and reliable that Fulton is backing it with an unprecedented LIMITED LIFETIME WARRANTY.

- Corrosion resistant coatings cover internal and external components - will hold up in harsh environments
- Ergonomic design - crank, release pin and integrated wheel wedge are made of strong, engineered plastic for a comfortable touch
- Stylish design - compliment your boat and customize your trailer's styling
- Lifetime limited warranty
- Sealed and lubricated one-piece gearbox
- Twin track and wide track versions available
- Available in bolt-on and weld-on versions for up to 5" tongues
- Handle Hold-Up secures handle to jack tube when in stowed position



F2® MARINE AND RECREATIONAL JACKS - TWIN TRACK MODELS

Part No.	Lift Cap. (lbs.)	Handle Style	Screw Travel	Mount Travel	Pull Pin Diameter	Description	Packaging
1413020134	1,600	Sidewind	10"	8"	9/16"	Individually Boxed. Includes Handle Hold-Up & Wheel Wedge Features, & Bolt-On Mounting Hardware for 3"x3" & 3"x4" Frames.	Ind. Box
1413060334	1,600	Sidewind	10"	8"	9/16"	3"x4" Pivot Housing. Includes Handle Hold-Up Feature & Weld-On Mounting Bracket & Hardware.	Bulk
1413130334	1,600	Sidewind	10"	8"	9/16"	4"x5" Pivot Housing. Includes Handle Hold-Up Feature & Bolt-On Mounting Hardware for 3"x5" Frame.	Bulk

F2® MARINE AND RECREATIONAL JACKS - WIDE TRACK MODELS

Part No.	Lift Cap. (lbs.)	Handle Style	Screw Travel	Mount Travel	Pull Pin Diameter	Description	Packaging
1413040134	1,600	Sidewind	10"	8"	9/16"	Individually Boxed. Includes Handle Hold-Up & Wheel Wedge Features, & Bolt-On Mounting Hardware for 3"x3" & 3"x4" Frames.	Ind. Box
1413050334	1,600	Sidewind	10"	8"	9/16"	3"x4" Pivot Housing. Includes Handle Hold-Up Feature & Weld-On Mounting Bracket & Hardware.	Bulk
1413140334	1,600	Sidewind	10"	8"	9/16"	4"x5" Pivot Housing. Includes Handle Hold-Up Feature & Bolt-On Mounting Hardware for 3"x5" Frame.	Bulk

NOTE: Contact Horizon Customer Service for package quantities.
Twin Wheel US Patent D568,575 and Wide Wheel US Patent D570,072 and Handle US Patent D577,175



5" Frame Model

1413230134

F2® MARINE AND RECREATIONAL JACKS

Fulton, the industry leader for high performance jacks, is proud to introduce another addition to the F2® family of trailer jacks. Our 2,000 lbs. lift capacity adjustable swivel with footplate jacks pack all of the features of the award winning Twin Track & Wide Track models, along with the unprecedented LIMITED LIFETIME WARRANTY. The 2,000 lbs. capacity jacks possess the following unique features.

- Heavy duty articulating footplate - 7" diameter cast footplate provides superior stability. Unique ball and socket connection between jack and footplate allows for whatever articulation is required to accommodate uneven surfaces
- 13" of swivel mount height adjustment
- Handle Hold-Up secures handle to jack tube when in stowed position
- Lifetime limited warranty



F2® MARINE AND RECREATIONAL JACKS - ADJUSTABLE SWIVEL WITH FOOTPLATE

Part No.	Lift Cap. (lbs.)	Handle Style	Screw Travel	Mount Travel	Pull Pin Diameter	Description	Packaging
1413200334	2,000	Sidewind	10"	13"	9/16"	Includes Handle Hold-Up Feature & Weld-On Mounting Bracket & Hardware for up to 5" Frames.	Bulk
1413230134	2,000	Sidewind	10"	13"	9/16"	Includes Handle Hold-Up Feature & Bolt-On Mounting Hardware for 3"x4" and 3"x5" Frames.	Ind. Box

F2® MARINE AND RECREATIONAL JACK ACCESSORIES / REPLACEMENT PARTS

Part No.	Description	Packaging
ACCESSORIES / REPLACEMENT PARTS		
500134	Handle/Crank Kit, Includes Handle Grip, Groove Pin & Mounting Hardware	Bagged
500129	Handle Holdup	Bagged
500135	Gearbox Cover Replacement Kit, Includes (4) Mounting Screws	Bagged
500136	Pull Pin Replacement Kit, Includes Spring & Retaining Ring	Bagged
500137	Bearing Replacement Kit, Includes (2) Washers	Bagged
500276	Replacement Part, F2 4" x 5" Mount w/Hardware	Bagged
500277	Weld-On Mounting Bracket & Hardware for 3"x4" Pivot Housing	Bagged
500314	Gear Kit, Includes Shim Washer 5/16" (1), Straight Pin 7/32" x 3/4" (1), Groove Pin 3/16" x 1-1/4" (1) & Washer 1/2" ID x 1-1/4" OD (1)	Bagged
500320	Jack Accessory, XP to F2 Adapter Kit, For F2 Swivel Mount w/4" Frame	Ind. Box
TWIN TRACK REPLACEMENT PARTS		
500130	Twin Track Wheel Replacement Kit, Includes (2) Wheels & Mounting Hardware	Bagged
500138	Twin Track Wheel Only (1)	Bagged
500132	Twin Track Wheel Wedge Kit, Includes Mounting Hardware	Bagged
WIDE TRACK REPLACEMENT PARTS		
500131	Wide Track Wheel Replacement Kit, Includes Wheel & Mounting Hardware	Bagged
500133	Wide Track Wheel Wedge Kit, Includes Mounting Hardware	Bagged



1413250334

F2® A-FRAME JACK AND COUPLER COMBINATION

Fulton expands the F2® family of trailer jacks with the adjustable height A-Frame jack and coupler combination. In addition to all the features of the award winning F2® jacks these models include the following unique features.

- F2® Coupler, Class 4, with special cutout mounting area to accept jack
- Versatile handle orientation mounting options: front, driver side or passenger side facing
- 2,000 lbs. lift capacity
- Removable foot/wheel options (purchase separately):
 7" round articulating footplate (2,000 lbs. lift capacity)
 7" diameter twin track wheel (1,600 lbs. lift capacity)
 8" diameter wide track wheel (1,600 lbs. lift capacity)
- Lifetime limited warranty



44305F0317

F2® A-FRAME JACK AND COUPLER COMBINATION

Part No.	Lift Cap. (lbs.)	Handle Style	Screw Travel	Description	Packaging
1413250334	2,000	Sidewind	9"	Adjustable Height A-Frame Jack. NOTE: Requires F2 Coupler	Bulk
44305F0317				Coupler, Class 4, 2-5/16" Ball, 10,000 lbs. Capacity Coupler	Bulk
ACCESSORY PARTS - REMOVABLE FOOT / WHEEL OPTIONS					
500265				7" Twin Track Wheels, Includes Pull Pin Assembly	Bulk
500266				8" Wide Track Wheel, Includes Pull Pin Assembly	Bulk
500267				7" Round Articulating Footplate, Includes Pull Pin Assembly	Bulk
REPLACEMENT PARTS					
500268				Mounting Hardware, Includes: Hex Head Bolt 3/8" - 16 UNC (3) & Lock Washer 3/8" (3)	Poly Bag
500134				Handle / Crank Kit, Includes: Handle Grip, Groove Pin & Mounting Hardware	Bagged
500129				Handle Holdup	Bagged
500135				Gearbox Cover Replacement Kit, Includes: (4) Mounting Screws	Bagged
500137				Bearing Replacement Kit, Includes: (2) Washers	Bagged
500134				Gear Kit, Includes: (1) Shim Washer 5/16", (1) Straight Pin 7/32" x 3/4", (1) Groove Pin 3/16" x 1-1/4", & (1) Washer 1/2" ID x 1-1/4" OD	Bagged

Twin Wheel US Patent D568,575 and Wide Wheel US Patent D570,072 and Handle US Patent D577,175



500265



500266



500267



TruTurn 360



PREMIUM FINISH

- Environmentally friendly
- Self-healing
- Maximum corrosion resistance
- Used in salt water environments and other demanding climate applications



141133

XLT™ MARINE AND RECREATIONAL JACKS

- Patent pending TruTurn 360 system delivers best in class castering performance.
- Raises & lowers 35% faster than the competition.
- Patented inner and outer tube bushings provide a tight fit and lessen tube drag.
- Premium Sharkskin™ finish for optimum corrosion resistance.
- 20% more screw travel than conventional jacks.
- Stylized handles with soft touch grips.
- Grease fittings in key locations for easy lubrication.
- 5 year limited warranty

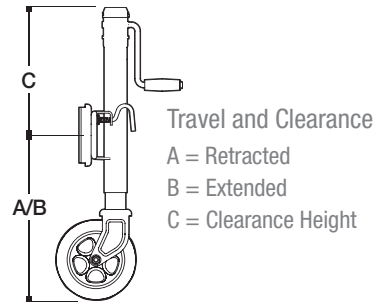

MARINE AND RECREATIONAL JACKS - PATENTED BOLT-THRU SWIVEL

Part No.	Lift Capacity (lbs.)	Handle Style	Travel	Measurements			Description	Lbs.	Pkg.
				A Retracted	B Extended	C Clearance			
141132	1,500	Sidewind	12"	14.5"	26.6"	15.9"	Swing Away, Weld-On, Patent Pending TruTurn 360 Castering System (P9012-00 Weld-On Mount & Hardware Sold Separately)	19.0	Bulk
141133	1,500	Sidewind	12"	10.5"	22.6"	15.9"	Swing Away, Bolt-On (Mounting Hardware Incl.), Patent Pending TruTurn 360 Castering System	20.5	Ind. Box
141135	1,500	Sidewind	10"	12.75"	22.75"	12.5"	Swing Away, Weld-On, Patent Pending TruTurn 360 Castering System (P9012-00 Weld-On Mount & Hardware Sold Separately)	16.5	Bulk

REPLACEMENT PART

Part No.	Description
500365	Replacement Part, Pull Pin for #141132 and #141133
0933306S00	Replacement Part, Service Kit, Includes: (2) Gears, (1) Pin, (1) Washer, (1) Spacer, & (2) Flanged Bushings



MARINE AND RECREATIONAL JACKS

Designed for use with marine and utility trailers, Fulton brand tongue jacks are time- tested and application-proven. Our bolt-on versions include all necessary mounting hardware. For weld-on applications, we offer two styles of mounts for both 1/2" and 3/8" pull pin models. The Fulton brand bolt-thru swivel mounts (U.S. PAT. 6,302,381) use 3-D formed heavy-gauge steel stampings and a proprietary bushing material for a mount with minimal deflection and maximum support. All mounts fit up to a 3" x 5" trailer frame.

- Extensive choice of popular models, Sidewind Crank with Round or Square Tubes
- Strong proprietary bushing materials
- Stable formed heavy-gauge steel construction
- Dependable design
- Lift capacity from 400 lbs. to 5,000 lbs.
- 5 year limited warranty



XP10

XP15

XPD15L

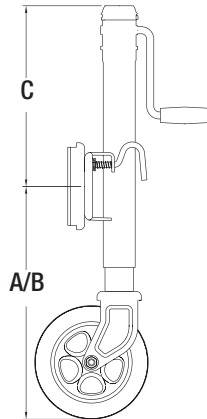

Travel and Clearance Diagram

- A= Retracted
- B= Extended
- C= Clearance Height



- 600 hour salt spray rating per ASTM B117



EJ1000

TJ1200

(1 Hour Clear Zinc Plating)



HD5000

HD2500

MARINE AND RECREATIONAL JACKS

MARINE AND RECREATIONAL JACKS - PATENTED BOLT-THRU SWIVEL

Part No.	Lift Capacity (lbs.)	Handle Style	Travel	Measurements			Description	Finish	Pull Pin Dia.	Pkg.
				A Retracted	B Extended	C Clearance				
XP10 0101	1,200	Sidewind	10"	12.5"	22.5"	10.5"	6" Diameter Wheel, Bolt-On , Mounting Hardware for up to 5" Frame Included, Handle & Wheel Unassembled	Z-Max 600 Clear Zinc	1/2"	Ind. Box
XP10 0301	1,200	Sidewind	10"	12.5"	22.5"	10.5"	6" Diameter Wheel, Bolt-On , Mounting Hardware for up to 5" Frame Included	Z-Max 600 Clear Zinc	1/2"	Bulk
XP10W 0301	1,200	Sidewind	10"	12.5"	22.5"	10.5"	6" Diameter Wheel, Weld-On , P9012-00 Weld-On Mount & Hardware SOLD SEPARATELY	Z-Max 600 Clear Zinc	1/2"	Bulk
XP100W0301	1,200	Sidewind	10"	14.8"	24.8"	10.5"	8" Diameter Spoked Wheel, Weld-On , P9012-00 Weld-On Mount & Hardware SOLD SEPARATELY	Z-Max 600 Clear Zinc	1/2"	Bulk
XP10WC0301	1,200	Sidewind	10"	12.9"	22.9"	10.5"	Improved Castering Performance - Yoke/Wheel Swivel Independent of Inner Tube, 6" Diameter Wheel, Weld-On , P9012-00 Weld-On Mount & Hardware SOLD SEPARATELY	Z-Max 600 Clear Zinc	1/2"	Bulk
XP15 0101	1,500	Sidewind	10"	13.0"	23.0"	12.4"	8" Diameter Spoked Wheel, Bolt-On , Mounting Hardware for up to 5" Frame Included, Handle & Wheel Unassembled	Z-Max 600 Clear Zinc	1/2"	Ind. Box
XP15 0301	1,500	Sidewind	10"	13.0"	23.0"	12.4"	8" Diameter Spoked Wheel, Bolt-On , Mounting Hardware for up to 5" Frame Included	Z-Max 600 Clear Zinc	1/2"	Bulk
XP15W 0301	1,500	Sidewind	10"	13.0"	23.0"	12.4"	8" Diameter Spoked Wheel, Weld-On , P9012-00 Weld-On Mount & Hardware SOLD SEPARATELY	Z-Max 600 Clear Zinc	1/2"	Bulk
XP15WC0301	1,500	Sidewind	10"	13.6"	23.6"	12.4"	Improved Castering Performance - Yoke/Wheel Swivel Independent of Inner Tube, 8" Diameter Spoked Wheel, Weld-On , P9012-00 Weld-On Mount & Hardware SOLD SEPARATELY	Z-Max 600 Clear Zinc	1/2"	Bulk
1411300301	1,500	Sidewind	10"	15.6"	25.6"	10.4"	Ideal for Torsion Axle Trailers - Mount 2" Higher, Improved Castering Performance - Yoke/Wheel Swivel Independent of Inner Tube, 8" Diameter Spoked Wheel, Weld-On , P9012-00 Weld-On Mount & Hardware SOLD SEPARATELY	Z-Max 600 Clear Zinc	1/2"	Bulk
XP15L 0101	1,500	Sidewind	12"	13.0"	25.0"	14.4"	Additional 2" of Travel, 8" Diameter Spoked Wheel, Bolt-On , Mounting Hardware for up to 5" Frame Included, Handle & Wheel Unassembled	Z-Max 600 Clear Zinc	1/2"	Ind. Box
XP15L 0301	1,500	Sidewind	12"	13.0"	25.0"	14.4"	Additional 2" of Travel, 8" Diameter Spoked Wheel, Bolt-On , Mounting Hardware for up to 5" Frame Included	Z-Max 600 Clear Zinc	1/2"	Bulk
XPD15L0101	1,500	Sidewind	12"	13.1"	25.1"	12.4"	Dual Wheel , Additional 2" of Travel, 6" Diameter Wheels, Bolt-On , Mounting Hardware for up to 5" Frame Included, Handle & Wheel Unassembled	Z-Max 600 Clear Zinc	1/2"	Ind. Box
XPD15L0301	1,500	Sidewind	12"	13.1"	25.1"	12.4"	Dual Wheel , Additional 2" of Travel, 6" Diameter Wheels, Bolt-On , Mounting Hardware for up to 5" Frame Included	Z-Max 600 Clear Zinc	1/2"	Bulk

MARINE AND RECREATIONAL JACKS - RETAINING RING SWIVEL

Part No.	Lift Capacity (lbs.)	Handle Style	Travel	Measurements			Description	Finish	Pull Pin Dia.	Pkg.
				A Retracted	B Extended	C Clearance				
1410050149*	400	N/A	N/A	14.5"	N/A	4.5"	Swiveling Trailer Stand, 6" Diameter Wheel, Bolt-On , Mounting Hardware for up to 5" Frame Included, Wheel Unassembled	Silver Powder Coat	3/8"	Ind. Box
TJ12000101	1,200	Sidewind	10"	12.7"	22.7"	11.4"	6" Diameter Wheel, Bolt-On , Mounting Hardware for up to 5" Frame Included, Handle & Wheel Unassembled	Z-Max 600 Clear Zinc	3/8"	Ind. Box
TJ120W0301	1,200	Sidewind	10"	12.7"	22.7"	11.4"	6" Diameter Wheel, Weld-On , Mount & Retaining Ring Included, Both Shipped Loose/Unassembled	Z-Max 600 Clear Zinc	3/8"	Bulk
EJ10000101*	1,000	Sidewind	10"	13.0"	23.0"	11.0"	6" Wheel, Clear Zinc Finish, Bolt-On, Fits up to 3" x 5" Trailer Frame	100 Hr. Clear Zinc	3/8"	Ind. Box
EJ10000301*	1,000	Sidewind	10"	13.0"	23.0"	11.0"	6" Wheel, Clear Zinc Finish, Bolt-On, Fits up to 3" x 5" Trailer Frame	100 Hr. Clear Zinc	3/8"	Bulk

*1 year limited warranty

MARINE AND RECREATIONAL JACKS - FIXED MOUNT

Part No.	Lift Capacity (lbs.)	Handle Style	Travel	Measurements			Description	Finish	Pkg.
				A	B	C			
TJ12220301	1,200	Sidewind	15"	9.3"	24.3"	19.5"	6" Diameter Wheel, Bolt-On , Mounting Hardware for up to 5" Frame Included	Z-Max 600 Clear Zinc	Bulk
HD25000101	2,500	Sidewind	28"	7.00"	35.5"	19.25"	Heavy Duty Square, Drop Leg Jack , 3.8" x 7.5" Footplate, Bolt-On , Mounting Hardware for up to 5" Frame Included, Handle Unassembled, Travel Includes Drop Leg	Z-Max 600 Clear Zinc	Ind. Box
35SM28FZ	2,500	Sidewind	28"	7.00"	35.5"	19.25"	Heavy Duty Square, Drop Leg Jack , 3.8" x 7.5" Footplate, Bolt-On , Mounting Hardware for up to 5" Frame Included, Travel Includes Drop Leg	Z-Max 600 Clear Zinc	Bulk
HD50000101	5,000	Sidewind	28"	6.5"	35.0"	18.5"	Heavy Duty Square, Drop Leg Jack , 6.0" x 8.0" Footplate, Bolt-On , Mounting Hardware for 4", 5", & 6" High Frames Included, Travel Includes Drop Leg	Z-Max 600 Clear Zinc	Ind. Box
HD50000301	5,000	Sidewind	28"	6.5"	35.0"	18.5"	Heavy Duty Square, Drop Leg Jack , 6.0" x 8.0" Footplate, Bolt-On , Mounting Hardware for 5" High Frame Included, Travel Includes Drop Leg	Z-Max 600 Clear Zinc	Bulk



P9012-00



500286



500349

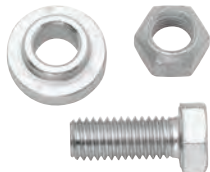

0933325S00

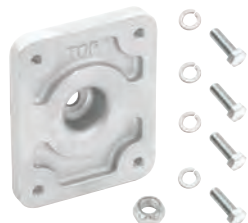

500320

MARINE AND RECREATIONAL JACK ACCESSORIES

Part No.	Description
MOUNTING KITS	
P9012-00	Weld-On Mounting Kit, for XP Series Jacks
500286	Bolt-On Mounting Hardware Kit
500349	Bolt on Mounting Kit for XP Series Jacks
0933325S00	Mounting Hardware & Bushing for XP Bolt-Thru Swivel Mount
ADAPTER KITS	
500320	Jack Accessory, XP to F2 Adapter Kit, For F2 Swivel Mount w/4" Frame

MARINE AND RECREATIONAL JACK PARTS

Part No.	Description / Application
HANDLE KITS	
0933301S00	Includes (1) Handle Assembly with Plastic Handle Roller, (1) Groove Pin, & (1) Flanged Bushing TJ503/C, TJU503, PMJ53, TJ507/C, PMJ75, CS750, GR700/TJ712, XP10/L/W/WC, XP100
0933305S00	Includes (1) Handle Assembly with Plastic Handle Roller, (1) Groove Pin, & (1) Flanged Bushing TJ1055, TJ1057, TJ1222, TJ255, TJD125, TJ122F, XP15/L/W/WC, XP15L, HD2500
BEVEL GEAR KITS	
0933302S00	Includes (2) Gears, (1) Groove Pin, (1) Pin, (1) Washer, & (1) Flanged Bushing TJ503, XP10 (all 1,200 lbs. capacity)
0933306S00	Includes (2) Gears, (1) Groove Pin, (1) Pin, (1) Washer, (1) Spacer, & (2) Flanged Bushings TJ1055, TJ1057, TJ1222, TJ1255, TJD125, TJ122F, XP15/L/W/WC, XPF15L, HD2500
PLUNGER PIN KITS	
0933307S00	Includes (1) 1/2" Plunger Pin, (1) Plunger Pin Cap, (1) Washer, (1) Cotter Pin, & (1) Spring TJ1055, TJ1057, TJ1255, TJD125, TJ122F, XP15/L/W/WC, XPF15L, XP10 (all 1,200 lbs. capacity)
WHEEL REPAIR KIT	
6811S00	All 6" models including TJ600T (excluding TJD125, TJD103)
CAPS	
500325	Cap - HD2500 Jack
500322	Cap - TJ1200 & EJ1000
500323	Cap - XP10
500324	Cap - XP15

NOTE: RED part numbers indicate discontinued items.

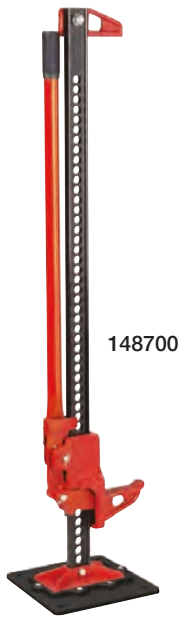

MULTI-JACK

A versatile tool for lifting, pulling, clamping, and spreading, the BULLDOG 48" Multi-Jack is always handy to have along on 4x4s and other off-road vehicles. You'll really appreciate its power when it makes backbreaking jobs like tearing out stumps and pulling up posts a breeze.



- ALL-STEEL CONSTRUCTION - Provides reliable strength
- RUGGED RATCHET DESIGN - Holds up to time and heavy use
- 36" STEEL HANDLE - Multiplies effort while keeping the operator clear
- LARGE 10" X 10" BASE - Increases ground contact surface area
- 35" OF TRAVEL - Lets you lift loads from 5" to 40" with ease
- SIMPLE DESIGN - Packs power into 30 lbs. of multipurpose equipment

MULTI-JACK

Part No.	Capacity	Travel	Extended	Description	Pkg.	Unit Wt. Lbs.
148700	Tested to 7,000 lbs. (4,660 lbs. maximum rated load at 48")	35"	48"	Multipurpose Jack	Ind. Pack	30.0

STABILIZERS



Square tube stabilizers are fabricated from high strength, structural steel tubing, and are yellow zinc-plated for excellent corrosion-resistance. Common applications include cargo trailers, industrial implements, and equipment outriggers.

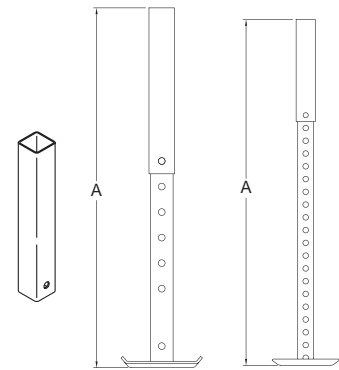

Travel and Clearance Diagram
A= Range

STABILIZERS

Part No.	Static Capacity (lbs.)	Adjustment Range (A)	Overall Length Dimension	Description	Pkg.
STABILIZER - KIT					
SJL8 0300	2,000	8" - 27"	20" drop leg, 8" outer	Assembly drop leg and 1-1/2" outer tube (includes pin)	Bulk
STABILIZER - TUBE AND DROP LEGS					
SJ1 0300	3,000	N/A	13"	2" square outer tube, oil finish (pin not included)	Bulk
SJ2 0324	3,000	25" - 37"	28.75"	Square drop leg with adjustment holes (pin not included)	Bulk
SJ4 0324	3,000	18" - 28"	20"	Square drop leg with adjustment holes (pin not included)	Bulk
STABILIZER - DROP LEG					
SJW 0324	3,000	Up to 24"	30.5"	Square drop leg with adjustment holes, foot at 30 degree angle to tube. NOTE: Will not work with SJ1 0300 tube.	Bulk



028499



HEAVY DUTY COUPLERS

Designed for utility, horse/livestock, cargo, and construction trailer applications, BULLDOG Collar-Lok™ are the strongest in the industry. The BULLDOG design features the only automatic and continuously tight ball fit in the industry. A variety of coupler styles, tongue mounts, and latches allow configurations to match virtually any trailer. Adjustable couplers assure level operation for trailers when pulled by a variety of different vehicles.

- Easiest to use
- Strong in both static and dynamic loading conditions
- Hinged ball socket for easy hook up
- Clear, visual indication of proper closure
- In compliance with SAE standard J684



028655



028630





COLLAR-LOK™ COUPLERS - TONGUE MOUNTS

	No. 2 Tongue Mount 2-1/4" outside diameter x 1-3/4" inside diameter steel tubing.
	No. 4 Tongue Mount High-strength steel for 3" square or rectangular trailer tongue.
	No. 5 Tongue Mount High-strength steel for 3-1/2" OD round trailer tongue.
	No. 6 Channel Mount Fits inside 3" wide channel.
	No. 8 Tongue Mount High-strength steel for 50-degree trailer tongue (tapped mounting holes optional for A-frame style jacks).

COLLAR-LOK™ COUPLERS - "B" STYLE COUPLERS

	2B Style 5,000 lbs. gross trailer weight for 2" ball.
	3B Style 7,000 lbs. gross trailer weight for 2" ball.
	4B Style 12,500 lbs. gross trailer weight for 2-5/16" ball.
	5B Style 15,000 lbs. gross trailer weight for 2-5/16" ball.

COLLAR-LOK™ COUPLERS - LATCHES

	L - Low Profile (No. 8 Tongue Mount only)
	H - High Profile
	M - Pin Only

028657





HEAVY DUTY COUPLERS - COLLAR-LOK™ COUPLERS

Part No.	Model No.	Gross Trailer Weight	Overall Length	Latches	Ball Size	SAE Class	Coupler Style	Description	Unit Weight Lbs.
NO. 2 ROUND TUBULAR TONGUE MOUNT									
028381	2B2H	5,000	10-3/4"	High Profile	2"	III	2B Style	2-1/4" OD x 1-3/4" ID, steel tubing	8.0
028242	2B2M	5,000	10-3/4"	Pin Style	2"	III	2B Style	2-1/4" OD x 1-3/4" ID, steel tubing	8.0
028461	4B2H	12,500	12-3/4"	High Profile	2-5/16"	N/A	4B Style	2-1/4" OD x 1-3/4" ID, steel tubing	8.0
028442	4B2M	12,500	12-3/4"	Pin Style	2-5/16"	N/A	4B Style	2-1/4" OD x 1-3/4" ID, steel tubing	8.0
NO. 4 3" SQUARE/RECTANGULAR TONGUE MOUNT									
028382 ♦	2B4H	5,000	16-1/4"	High Profile	2"	III	2B Style	High-strength steel for 3" square or rectangular trailer tongue	10.5
028244	2B4M	5,000	16-1/4"	Pin Style	2"	III	2B Style	High-strength steel for 3" square or rectangular trailer tongue	10.5
028387 ♦	3B4H	7,000	16-1/4"	High Profile	2"	IV	3B Style	High-strength steel for 3" square or rectangular trailer tongue	11.5
028243	3B4M	7,000	16-1/4"	Pin Style	2"	IV	3B Style	High-strength steel for 3" square or rectangular trailer tongue	11.5
028462 ♦	4B4H	12,500	16-1/2"	High Profile	2-5/16"	N/A	4B Style	High-strength steel for 3" square or rectangular trailer tongue	12.0
028444	4B4M	12,500	16-1/2"	Pin Style	2-5/16"	N/A	4B Style	High-strength steel for 3" square or rectangular trailer tongue	12.0
NO. 5 3" ROUND STRAIGHT TONGUE MOUNT									
028383	2B5H	5,000	16-1/4"	High Profile	2"	III	2B Style	High-strength steel for 3-1/2" OD round trailer tongue	10.5
NO. 6 ADJUSTABLE CHANNEL MOUNT									
028390 ♦	3B6M	7,000	9.5"	Pin Style	2"	IV	3B Style	Fits inside 3" wide channel	10.0
028584	3B6M	7,000	9.5"	Pin Style	2"	IV	3B Style	Rigid mount, 4-bolt design, fits inside 3" wide channel	10.0
028630 ♦	4B6M	12,500	10"	Pin Style	2-5/16"	N/A	4B Style	Fits inside 3" wide channel	11.5
028585	4B6M	12,500	10"	Pin Style	2-5/16"	N/A	4B Style	Rigid mount, 4-bolt design, fits inside 3" wide channel	11.5
028657	5B6M	15,000	10"	Pin Style	2-5/16"	N/A	5B Style	Fits inside 3" wide channel	11.7
NO. 8 A-FRAME TONGUE MOUNT									
028384	2B8H	5,000	16"	High Profile	2"	III	2B Style	High-strength steel for 50° trailer tongue	12.0
028288 ♦	2B8L	5,000	16"	Low Profile	2"	III	2B Style	High-strength steel for 50° trailer tongue	12.0
028386	3B8H	7,000	16"	High Profile	2"	IV	3B Style	High-strength steel for 50° trailer tongue	13.0
028287 ♦	3B8L	7,000	16"	Low Profile	2"	IV	3B Style	High-strength steel for 50° trailer tongue	13.0
028463	4B8H	12,500	16-1/2"	High Profile	2-5/16"	N/A	4B Style	High-strength steel for 50° trailer tongue	14.0
028499 ♦	4B8L	12,500	16-1/2"	Low Profile	2-5/16"	N/A	4B Style	High-strength steel for 50° trailer tongue	14.0
028656	5B8H	15,000	16-1/2"	High Profile	2-5/16"	N/A	5B Style	Black primed finish	16.0
028655	5B8L	15,000	16-1/2"	Low Profile	2-5/16"	N/A	5B Style	Black primed finish	16.0
REPLACEMENT PART									
024200	N/A	N/A	N/A	High Profile	N/A	N/A	N/A	Collar-Lok™ Coupler kit, includes high profile latch handle, latch wire, latch pin, push nut, and cotter pin	N/A
500354	N/A	N/A	N/A	N/A	N/A	N/A	N/A	Coupler Cap Spring	N/A

NOTE: Other custom-made designs are available upon request. ♦ DENOTES MOST POPULAR

⚠ WARNING

Failure to close coupler securely before towing or failure to use with specified ball size may result in serious injury or death.



44150W

CAST COUPLERS

Designed for utility, horse/livestock, cargo, and construction trailer applications, BULLDOG Couplers are the strongest in the industry. The patented cast head "Wedge-Latch" coupler design is offered in heavy-duty, A-frame, and convenient adjustable height models. Adjustable couplers assure level operation for trailers when pulled by a variety of different vehicles. The replaceable latching hardware allows for longer service life.

- Quick and easy to engage
- Strong and secure on the road
- Patented Wedge-Latch® ball clamp design
- Quick to hook up and disconnect
- In compliance with SAE standard J684



Wedge-Latch® A-Frame Mount, Patent Pending, Cast A-frame couplers with patented replaceable hardware for longer service life



Wedge-Latch® Flat Plate Mount



Wedge-Latch® Adjustable Height Coupler
US Patent 6,505,849



Adjustable Height Bracket

HEAVY DUTY COUPLERS - CAST COUPLERS

Part No.	Gross Trailer Weight	Overall Length	Latches	Ball Size	SAE Class	Description	Unit Weight Lbs.
WEDGE-LATCH® CAST HEAD COUPLERS							
43805W0317	8,000	18"	Wedge-Latch	2"	IV	Round jack mount, 50° A-frame	14.3
44125W0317	12,500	18"	Wedge-Latch	2-5/16"	IV	Round jack mount, 50° A-frame	18.6
44150W0317	15,000	18"	Wedge-Latch	2-5/16"	IV	Round jack mount, 50° A-frame	18.6
44150WQ317	15,000	18"	Wedge-Latch	2-5/16"	IV	Square jack mount, 50° A-frame	18.6
44150WH301	15,000	18"	Wedge-Latch	2-5/16"	IV	Round jack mount, 50° A-frame, for bolt-on applications	18.6
WEDGE-LATCH® FLAT MOUNT CAST HEAD COUPLERS							
4420000317	20,000	N/A	Wedge-Latch	2-5/16"	N/A	Cast head, 4-1/2" mount pattern, grey primer coat	14.0
4425000317	25,000	N/A	Wedge-Latch	2-5/16"	N/A	Cast head, 4-1/2" mount pattern, grey primer coat	15.0
ACCESSORY PART - WEDGE-LATCH® FLAT MOUNT CAST HEAD COUPLER							
PL4 0201		N/A	N/A	N/A	N/A	Pin/Lanyard 5/16" with 4 Link Chain & Tab	0.75
WEDGE-LATCH® ADJUSTABLE HEIGHT CAST HEAD COUPLERS							
A200C 0317	8,000	8-1/2"	Wedge-Latch	2"	IV	Cast head includes mounting hardware, adjustable height	9.5
A2003C0317	8,000	9-1/4"	Wedge-Latch	2"	IV	Cast head includes bolts and 3-position channel, adjustable height	13.7
A2005C0317	8,000	9-1/4"	Wedge-Latch	2"	IV	Cast head includes bolts and 5-position channel, adjustable height	15.8
A256C 0317	14,000	9-1/4"	Wedge-Latch	2-5/16"	IV	Cast head includes mounting hardware, adjustable height	10.1
A2563C0317	14,000	9-1/2"	Wedge-Latch	2-5/16"	IV	Cast head includes bolts and 3-position channel, adjustable height	14.3
A2565C0317	14,000	9-1/2"	Wedge-Latch	2-5/16"	IV	Cast head includes bolts and 5-position channel, adjustable height	16.4
ACCESSORY / REPLACEMENT PARTS - ADJUSTABLE HEIGHT CHANNEL BRACKET							
AC300 0300		8" Height	N/A	N/A	N/A	4-hole, 3-position bracket, with 4" of vertical adjustment, adjustable height	4.18
AC500 0300		11-3/4" Height	N/A	N/A	N/A	6-hole, 5-position bracket, with 8" of vertical adjustment, adjustable height	6.32
66 0801		N/A	N/A	2"	N/A	2" Ball size Wedge-Latch® repair kit. Includes latch lever, ball clamp, and replacement hardware	1.0
67 0801		N/A	N/A	2-5/16"	N/A	2-5/16" Ball size Wedge-Latch® repair kit. Includes latch lever, ball clamp, and replacement hardware	1.0

NOTE: Other custom-made designs are available upon request.

ADJUSTABLE HEIGHT HEAVY DUTY COUPLERS



A200S 0303

Designed for utility, horse/livestock, cargo and construction trailer applications, BULLDOG Couplers are the strongest in the industry. The patented cast head "Wedge-Latch" coupler design is offered in heavy-duty, A-frame, and convenient adjustable height models. Adjustable couplers assure level operation for trailers when pulled by a variety of different vehicles. The replaceable latching hardware allows for longer service life.

- Quick and easy to engage
- Strong and secure on the road
- Patented Wedge-Latch ball clamp design
- Quick to hook up and disconnect
- In compliance with SAE standard J684

ADJUSTABLE HEIGHT COUPLERS

Part No.	Gross Trailer Weight	Overall Length	Ball Size	Description	Unit Wt. Lbs.
A200S 0303	8,000	9.00"	2"	Black E-Coat Finish Mounting Hardware Included, Mounting Bracket Sold Separately	7.90
A256S 0303	14,000	9.50"	2-5/16"	Black E-Coat Finish, Mounting Hardware Included, Mounting Bracket Sold Separately	8.00

MOUNTING BRACKETS

Part No.	Overall Height	Description	Unit Wt. Lbs.
AC300 0300	8.00"	3 Position, Raw Finish, Mounting Hardware Sold Separately	4.20
AC500 0300	11.75"	5 Position, Raw Finish, Mounting Hardware Sold Separately	6.40
024202	n/a	Mounting Hardware, Individually Bagged	1.00



E438050303



E338050303

YOKE COUPLER

Part No.	Gross Trailer Weight	Ball Size	Description	Unit Wt. Lbs.
E338050303	5,000	2"	Class III Coupler, Round Jack Mount 50° A-Frame, Black E-Coat Finish, Weld-on	7.80
E438050303	8,000	2"	Class IV Coupler, Round Jack Mount 50° A-Frame, Black E-Coat Finish Weld-on	7.80

⚠ WARNING

Failure to close coupler securely before towing or failure to use with specified ball size may result in serious injury or death.



0289500300



0287600300

ROUND GOOSENECK COUPLERS

BULLDOG gooseneck couplers are quick and easy to engage and strong and secure on the road. Our unique, patented, extruded locking plate design and high-strength steel components make BULLDOG gooseneck couplers 65% stronger than similar products.

- Easy-grip locking handle is accessible from any position, even with a glove on
- Self-centering locking plate lets you miss the ball by more than an inch
- Tight ball fit reduces jarring when changing speeds or on rough roads
- Heavy-duty construction provides unmatched strength
- User-friendly design is simple to use
- Quick to hook up and disconnect
- Easy vertical adjustment



GN24



0289500300



028900



0289600300

SQUARE GOOSENECK COUPLERS

You won't find a coupler that's faster or easier to use than the BULLDOG square gooseneck from Horizon Global. Its user-friendly design makes hookup and release swift and secure.

- Easy-grip locking handle is accessible from any position
- Self-centering locking plate lets you miss the ball by more than an inch
- Tight ball fit reduces jarring when changing speeds or on rough roads
- Heavy-duty high-strength fabricated steel components are as strong as heavy cast iron but lighter and less brittle
- User-friendly design enables quick, easy hookup and release
- Locking handle cover protects working parts
- Cam locking pin affords easy vertical adjustment
- Pinch bolt design



0289580300



0289590300

KING PIN GOOSENECK COUPLERS

- Allows gooseneck trailer to be towed with vehicles equipped with a fifth wheel hitch
- Feature dual set bolts
- Round model features exclusive load bearing pin
- Square model features exclusive load bearing pinch bolt
- Available with or without outer tube

NOTE: All BULLDOG® Gooseneck Couplers are in compliance with the SAE standard J2638 .

WARNING

Failure to close coupler securely before towing or failure to use with specified ball size may result in serious injury or death.

ROUND GOOSENECK COUPLERS

Part No.	Capacity	Overall Height		Adjustment	Ball Size	Description	Unit Wt. Lbs.
		Retracted	Extended				
ROUND GOOSENECK FIXED COUPLER							
0287690300	20,000	33.00"		N/A	2-5/16"	Fixed base coupler.	38.0
ROUND GOOSENECK ADJUSTABLE COUPLER							
0287600300	20,000	29.20"		8.0"	2-5/16"	Adjustable gooseneck coupler.	46.0
0287610300	20,000	27.20"		8.0"	2-5/16"	Adjustable gooseneck coupler. No outer tube.	30.0
0287620300	20,000	29.30"		8.0"	2-5/16"	Adjustable gooseneck coupler with cap.	48.0
0287650300	20,000	28.60"		8.0"	2-5/16"	Adjustable gooseneck coupler. No outer tube. GN24 coupler head.	25.5
0287760300	20,000	29.50"		8.0"	2-5/16"	Adjustable gooseneck coupler. GN24 coupler head.	47.3
0289340317	25,000	28.10"		8.0"	2-5/16"	4.5" diameter outer tube, 4" diameter inner tube, with GN24 coupler head, 3/4" load bearing pin.	45.4
0289250300	25,000	29.30"		8.0"	2-5/16"	4.5" diameter outer tube, 4" diameter inner tube, with cast locking plates. 3/4" load bearing pin.	50.0
0289500300	30,000	29.30"		8.0"	2-5/16"	4.5" diameter outer tube, 4" diameter inner tube, with cast locking plates. 3/4" load bearing pin.	52.0
GOOSENECK COUPLER HEAD							
GN24 0200	24,000	N/A		N/A	2-5/16"	Cast steel gooseneck coupler designed for easy welding to 3" or 4" diameter tubing. Quick and easy latching action eliminates need to be in tow vehicle for hook-up.	5.5
GOOSENECK COUPLER OUTER TUBE							
0233010300						Outer tube only. 20" length, 4.5" round tube, with hole for 3/4" load bearing pin, (1) set bolt.	17.2
0233100300						Outer tube only. 20" length, 4.5" round tube, with hole for 3/4" load bearing pin, (2) set bolts.	17.7
REPLACEMENT PART - GOOSENECK COUPLER HEAD GN24 REPAIR KIT							
1542S01	N/A	N/A		N/A	N/A	Kit includes torsion spring, coupler locking shaft, curved handle assembly, 3/4" shaft retaining ring, centerlock nut 1/2-13	N/A
REPLACEMENT PART - GOOSENECK COUPLER KIT							
0287740300	N/A	N/A		N/A	2-5/16"	Kit includes coupler assembly, locking pin assembly, locking pin cover, BULLDOG label, and warning label.	10.0
0233060301	N/A	N/A		N/A	N/A	Replacement Pin Kit, includes cotter pin.	N/A
500296	N/A	N/A		N/A	N/A	Gooseneck couplers bolt kit. Includes jam nut (1), set screw (1), adjusting nut (1).	N/A

SQUARE GOOSENECK ADJUSTABLE COUPLERS

Part No.	Capacity	Overall Height		Adjustment	Ball Size	Description	Unit Wt. Lbs.
		Retracted	Extended				
0289600300	25,000	32"	40"	8"	2-5/16"	4.5" square outer tube, 4.0" square inner tube. (1) 3/4" diameter set screw.	57.0
0288660300	25,000	30.75"	N/A	8"	2-5/16"	4.0" square inner tube only.	42.0
028900	30,000	32"	39"	7"	2-5/16"	4.5" square outer tube with .25" wall, 4.0" square inner tube with .313" wall. Includes topwind crank.	76.0
0289800300	30,000	32"	40"	8"	2-5/16"	4.5" square outer tube with, 4.0" square inner tube. (2) 3/4" diameter set bolts.	68.0

KING PIN GOOSENECK COUPLERS

Part No.	Capacity	Overall Height		Adjustment	Ball Size	Description	Unit Wt. Lbs.
		Retracted	Extended				
0289580300	25,000	23.3"	31.3"	8"	N/A	Round tube , raw finish, labels shipped loose.	57.5
0289640300	25,000	23.3"	31.3"	8"	N/A	Round tube , raw finish, labels shipped loose. Inner tube only.	37.1
0289590300	30,000	23.3"	31.3"	8"	N/A	Square tube , raw finish, labels shipped loose.	64.1
0289650300	30,000	23.3"	31.3"	8"	N/A	Square tube , raw finish, labels shipped loose. Inner tube only.	45.8

SERVICE KIT FOR SQUARE / SQUARE KING PIN GOOSENECK ADJUSTABLE COUPLERS

Part No.	Description
0289SB0140	Adjustable gooseneck pinch bolt kit



BX1® GOOSENECK COUPLERS

The BULLDOG BX1 coupler is the result of generations of design expertise and field experience. It incorporates innovative features that revolutionize the benefits available from a gooseneck coupler.

- Offers flexible mounting options with Next Generation locking plate coupler locking mechanism
- Makes hooking up, adjusting vertical height, and disconnecting easy
- Maintains smooth operation over time with grease fittings for every important operating part
- Operates easily with one hand thanks to new locking handle design
- Continuous tight ball fit - ever-increasing cam tightening mechanism
- Protects against wear with enclosed locking pin mechanism
- Resists theft with integrated feature to allow pad-locking the coupler to the ball (lock not included)
- Guides ball into socket more easily—letting you miss by more than an inch—with bottom locking plate 50% larger than competitors
- Lengthens life of locking mechanism with oil-impregnated bushings
- Allows shorter retracted length and less wasted length for trucks with high bed height via low-profile locking mechanism
- Fits ball better and reduces jarring through contour-formed edge on bottom locking plate
- Delivers unmatched strength through heavy-duty construction
- Innovations that improve security, service life, and functionality
- New ball pocket design provides contact on both sides of the ball for substantially improved pull out strength - the only sliding-plate design that transfers part of the load to the top locking plate rather than only the bottom locking plate

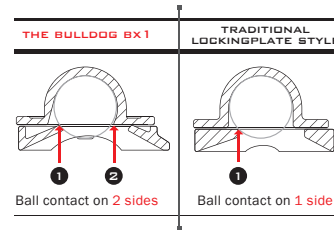

BX1® GOOSENECK COUPLERS

Part No.	Capacity	Overall Height		Adjustment	Ball Size	Description	Unit Wt. Lbs.
		Retracted	Extended				
1289030300	20,000	27.5"	35.5"	8"	2-5/16"	BX1 Coupler Round Tube	46.0
1289070300	20,000	22.6"	30.6"	8"	2-5/16"	BX1 Coupler Round Tube, Short Configuration	41.0
1289170300	20,000	N/A	N/A	8"	2-5/16"	BX1 Coupler Round Tube, Inner Tube Only	27.0
1289000300	25,000	27.5"	35.5"	8"	2-5/16"	BX1 Coupler Round Tube	48.0
1289020300	25,000	N/A	N/A	8"	2-5/16"	BX1 Coupler Round Tube, Inner Tube Only	30.4
1289080300	25,000	22.6"	30.6"	8"	2-5/16"	BX1 Coupler Round Tube, Short Configuration	44.0
1289130300	25,000	30.8"	38.8"	8"	2-5/16"	BX1 Coupler Square Tube	58.6
1289210300	25,000	N/A	N/A	8"	2-5/16"	BX1 Coupler Square, Inner Tube Only, Short Configuration	31.2
1289040300	30,000	22.6"	30.6"	8"	2-5/16"	BX1 Coupler Round Tube, Short Configuration	46.0
1289050300	30,000	N/A	N/A	8"	2-5/16"	BX1 Coupler Round Tube, Inner Tube Only, Short Configuration	29.0
1289140300	30,000	30.8"	38.8"	8"	2-5/16"	BX1 Coupler Square Tube	65.3
1289200300	40,000	22.0"	24.6"	2.6"	3"	BX1 Coupler Square Tube	58.2

ACCESSORIES

0233120300 Square Gooseneck Coupler Outer Tube, Weld On , 20" Length, 4-1/2" Tube, w/Hex Head Bolt Hole, Dual Set Bolts & Labels, 20.6 Lbs.

500356 5/16" Locking Pin for BX1 Gooseneck Couplers

SERVICE KIT

500289 Service kit for BX1 Gooseneck Coupler handle mechanism

REPLACEMENT PARTS

500353 Repair Kit (BX1, 3" Ball), Includes Handle Assembly, Locking Cam, Grease Fitting, Grooved Pin, Flanged Bushing & Torsion Spring

Patents Pending.

ROUND GOOSENECK COUPLERS

- 8" of Adjustment
- Handle hold-open feature
- Raw Finish
- 2 5/16" Ball Size

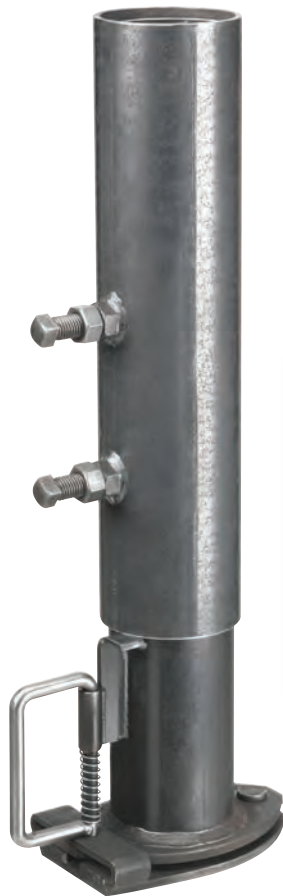

0287800300



Handle Hold-Open



0287820300



Load Bearing Pin

ROUND GOOSENECK COUPLERS

Part No.	Capacity	Overall Height Retracted	Adjustment	Ball Size	Description	Unit Wt. Lbs.
0287790300	20,000	26.70"	8.0"	2-5/16"	Raw Finish, 2 Set Screws	43.00
0287800300	25,000	26.70"	8.0"	2-5/16"	Raw Finish, 2 Set Screws	47.00
0287820300	25,000	26.70"	8.0"	2-5/16"	Raw Finish, 1 Set Screw, Load Bearing Pin	47.00



22300

STAMPED COUPLERS

The most popular coupler mechanism ever developed, the Fas-Lok® originated as a Fulton brand and is offered in a full line of SAE Class I through IV rated straight tongue stamped couplers. The Fas-Lok® latching mechanism allows quick and easy trailer hook-up, and is factory adjusted for convenience.



34300

STAMPED COUPLERS



Straight Tongue Fas-Lok®
Quick and easy trailer hook-up.



A-Frame
High-strength stamped couplers
for 50-degree frames.



44314R
US Patent
6,505,849

HANDI-GRIP COUPLER HANDLE



STAMPED COUPLERS WITH Z-MAX 600 SUPERIOR PLATING



Fulton coupler after
336 hours salt spray testing.



Competitor's coupler
after 336 hours salt spray testing.



STAMPED COUPLERS - STRAIGHT TONGUE STAMPED FAS-LOK® COUPLERS

Part No.	Gross Trailer Weight	Ball Size	SAE Class	Description	Finish	Packaging
E112000340	2,000	1-7/8"	I	2" Wide Channel, Clear Zinc Finish, No Product Label	100 Hr.	Bulk
11200 0317	2,000	1 7/8"	I	2" Wide Channel, Primed Finish, No Product Label	Primed	Bulk
11200 0101	2,000	1-7/8"	I	2" Wide Channel, Clear Zinc Finish, Labeled	100 Hr.	Ind. Labeled
E112500340	2,000	1-7/8"	I	2-1/2" Wide Channel, Clear Zinc Finish, No Product Label	100 Hr.	Bulk
11250 0317	2,000	1 7/8"	I	2 -1/2" Wide Channel, Primed Finish, No Product Label	Primed	Bulk
11250 0101	2,000	1 7/8"	I	2 -1/2" Wide Channel, Zinc Finish, Labeled	Zinc	Ind. Labeled
E113000340	2,000	1-7/8"	I	3" Wide Channel, Clear Zinc Finish, No Product Label	100 Hr.	Bulk
11300 0317	2,000	1 7/8"	I	3" Wide Channel, Primed Finish, No Product Label	Primed	Bulk
11300 0101	2,000	1-7/8"	I	3" Wide Channel, Clear Zinc Finish, Labeled	100 Hr.	Ind. Labeled
22200 0101	3,500	2"	II	2" Wide Channel, Labeled	Z-Max 600	Ind. Labeled
22200 0301	3,500	2"	II	2" Wide Channel, No Product Label	Z-Max 600	Bulk
22200 0317	3,500	2"	II	2" Wide Channel, Primed Finish, No Product Label	Primed	Bulk
22250 0101	3,500	2"	II	2-1/2" Wide Channel, Labeled	Z-Max 600	Ind. Labeled
22250 0301	3,500	2"	II	2-1/2" Wide Channel, No Product Label	Z-Max 600	Bulk
22250 0317	3,500	2"	II	2 -1/2" Wide Channel, Primed Finish, No Product Label	Primed	Bulk
22300 0101	3,500	2"	II	3" Wide Channel, Labeled	Z-Max 600	Ind. Labeled
22300 0301	3,500	2"	II	3" Wide Channel, No Product Label	Z-Max 600	Bulk
22300 0317	3,500	2"	II	3" Wide Channel, Primed Finish, No Product Label	Primed	Bulk
23300 0301	3,500	2"	II	3" Wide Channel, No Product Label, Holes on 3" Center	Z-Max 600	Bulk
34300 0301	5,000	2"	III	3" Wide Channel, No Product Label	Z-Max 600	Bulk
34300 0317	5,000	2"	III	3" Wide Channel, Primed Finish, No Product Label	Primed	Bulk
34600 0301	6,000	2"	IV	3" Wide Channel, Cast Ball Clamp, No Product Label	Z-Max 600	Bulk

STAMPED COUPLERS - A-FRAME STAMPED COUPLERS

Part No.	Gross Trailer Weight	Ball Size	SAE Class	Description	Finish	Packaging
E333050303	5,000	2"	III	50 Degree A-Frame (Weld-On)	Black E-Coat	Bulk
33305H0301	5,000	2"	III	50 Degree A-Frame (Bolt-On)	Zinc	Bulk
E443050303	10,000	2-5/16"	IV	50 Degree A-Frame (Weld-On), Low Profile Latch	Black E-Coat	Bulk
44305R0317	10,000	2-5/16"	IV	50 Degree A-Frame (Weld On), Wedge-Latch®	Primed	Bulk
44305R0500	10,000	2-5/16"	IV	50 Degree A-Frame (Weld On), Wedge-Latch®	Oily	Bulk
44311H0301	11,000	2-5/16"	IV	50 Degree A-Frame (Bolt-On), Wedge-Latch®	Zinc	Bulk
44314R0303	14,000	2-5/16"	IV	50 Degree A-Frame (Weld On), Wedge-Latch®	Black Paint	Bulk

STAMPED COUPLERS - HANDWHEEL COUPLERS

Part No.	Gross Trailer Weight	Ball Size	SAE Class	Description	Finish	Packaging
308 0217	5,000	2" - 2-1/8"	III	2-7/8" Channel, Handwheel Latch	Primed	Ind. Labeled

STAMPED COUPLERS - COUPLER ACCESSORIES / REPLACEMENT PARTS

Part No.	Description	Packaging
CH 0701	Handi-Grip Coupler Handle	Carded
52 0801	Kit, 308 repair, handwheel couplers	Display Bag
64 0801	Kit, 44305R, coupler replacement	Display Bag

*Couplers do not include hitch balls. Class III hardware couplers can be used on Class II trailers.
NOTE: Review price list or contact customer service for package quantities and full part number.*

⚠ WARNING

Failure to close coupler securely before towing or failure to use with specified ball size may result in serious injury or death.



Space Saving!



FOLD-AWAY™ HINGE KITS

Fulton High Performance Series Fold-Away™ hinge kits are ideal for boat trailers that can be just a little too long to fit inside smaller garages. These high quality, precision engineered products provide options for solving this common problem. Choose the Fold-Away™ product that fits your needs from among several varieties made to fit standard trailer tongue dimensions.

Bolt-on models feature Z-Max 600 hour clear zinc finish. Weld-on kits with raw finish are ideal for painting or galvanizing.

5 year limited warranty



• 600 hour salt spray rating per ASTM B117



FOLD-AWAY™ BOLT-ON HINGE KITS

- Converts standard trailer tongues into fold-away configurations while preserving the existing coupler
- Delivers strength at the pivot point with precisely machined heavy duty hinges made from die cast steel
- Easy to install bolt-on application with complete instruction manual
- Includes all mounting hardware
- Only recommended for trailers with steel tongues

FOLD-AWAY™ BOLT-ON HINGE KITS

Part No.	Gross Trailer Weight	Ball Size	SAE Class	Pivot Length	Description	Finish	Packaging
HDPB230101	Up To 5,000	N/A	N/A	Up to 48"	Bolt-On Hinge Kit, 2" x 3" Trailer Tongues	Z-Max 600	Display Box
HDPB330101	Up To 5,000	N/A	N/A	Up to 48"	Bolt-On Hinge Kit, 3" x 3" Trailer Tongues	Z-Max 600	Display Box
HDPB330301	Up To 5,000	N/A	N/A	Up to 48"	Bolt-On Hinge Kit, 3" x 3" Trailer Tongues	Z-Max 600	Bulk
HDPB340101	Up To 7,500	N/A	N/A	Up to 48"	Bolt-On Hinge Kit, 3" x 4" Trailer Tongues	Z-Max 600	Display Box
HDPB340301	Up To 7,500	N/A	N/A	Up to 48"	Bolt-On Hinge Kit, 3" x 4" Trailer Tongues	Z-Max 600	Bulk
HDPB350101	Up To 9,000	N/A	N/A	Up to 48"	Bolt-On Hinge Kit, 3" x 5" Trailer Tongues	Z-Max 600	Display Box

Includes Fold-Away hinges, mounting hardware, pivot bolt, pivot pin/clip. Torques bit included with retail display box packaged items.



FOLD-AWAY™ WELD-ON HINGE KITS

- Ideal for OEMs, a convenient option for custom trailers to utilize a pivot system
- Delivers strength at the pivot point with precisely machined heavy-duty hinges made from die cast steel
- Provides superior performance with unique patent pending offset design
- Works with actuators and standard coupler applications, note gross trailer weight
- Only recommended for trailers made of steel

FOLD-AWAY™ WELD-ON HINGE KITS (Consult pivot rating charts for allowed capacity.)

Part No.	Gross Trailer Weight	Ball Size	SAE Class	Pivot Length	Description	Finish	Packaging
HDPW230300	Up To 5,000	N/A	N/A	Up to 48"	Weld-On Hinge Kit, 2" x 3" Trailer Tongues	Raw Casting	Bulk
HDPW330300	Up To 5,000	N/A	N/A	Up to 48"	Weld-On Hinge Kit, 3" x 3" Trailer Tongues	Raw Casting	Bulk
HDPW340300	Up To 7,500	N/A	N/A	Up to 48"	Weld-On Hinge Kit, 3" x 4" Trailer Tongues	Raw Casting	Bulk
HDPW350300	Up To 9,000	N/A	N/A	Up to 48"	Weld-On Hinge Kit, 3" x 5" Trailer Tongues	Raw Casting	Bulk

Includes Fold-Away hinges (raw finish castings ideal for painting or galvanizing), zinc plated pivot bolt and nut, 5/8" diameter hitch pin and clip.

FOLD-AWAY™ HINGE KIT REPLACEMENT PARTS

Part No.	Description	Packaging
500334†	Pivot Pin 5/8" x 4-1/2" w/Cotter Pin & Lanyard for 3" x 3"	Poly Bag
500335†	Pivot Pin 5/8" x 5-1/2" w/Cotter Pin & Lanyard for 3" x 4"	Poly Bag
500336†	Pivot Pin 5/8" x 6-1/2" w/Cotter Pin & Lanyard for 3" x 5"	Poly Bag
500705	Pivot Rubber Bumpers (4)	Poly Bag

† = Available while supplies last.

Need a Winch? Does the application require Pulling or Lifting?

PULLING - SELECT A FULTON TRAILER WINCH

To Select Winch Capacity:

Minimum Winch Capacity = Maximum Weight of Boat, Including Motor, Fuel, Gear ÷ 2

Example:

Boat, Motor, Fuel, Gear Weight = 2,800 lbs.
 $2,800 \div 2 = 1,400$ lbs.

Select 142200 Winch, rated at 1,500 lbs.



142314



142430

COMMON PULLING APPLICATION



If shallow water or steep inclined launches are expected to be used ÷ Maximum Weight by 1.5

Example:

Boat, Motor, Fuel, Gear Weight = 3,100 lbs.
 $3,100 \div 1.5 = 2,067$ lbs.

Select 142410 Winch, rated at 2,600 lbs.

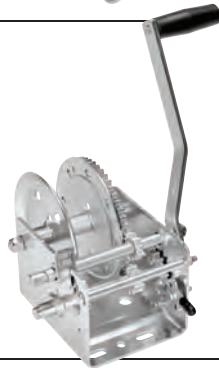

LIFTING - SELECT A FULTON BRAKE WINCH

To Select Winch Capacity:

Minimum Winch Capacity = Maximum Line Load,

Example: Maximum Line Load = 1,450 lbs.

Select 143100 Winch, rated at 1,500 lbs.



143200

COMMON LIFTING APPLICATIONS



NOTES

1. Fulton Winches are not designed to be human hoists and should never be operated when there are persons on or under the load being moved.
2. Fulton Winches are rated on the first layer of recommended line on the drum. For maximum efficiency use only the amount of line required. Derate the capacity 10% per additional layer of rope, strap, or cable.



PREMIUM FINISH

- Environmentally friendly
- Self-healing
- Maximum corrosion resistance
- Used in salt water environments and other demanding climate applications

F2® TRAILER WINCH

The F2® Winch addresses the need for attractive design in every element of a marine trailer. It complements the look of even high end boat and trailer combinations and continues the industry changing improvements in both performance and style of the Fulton F2® series of products.

- Models available with 1600, 2000 and 3200 lbs. capacity
- Attractive design to compliment the F2 jack series for a custom look
- Enclosed frame design for a sleek, strong stylish look to compliment your boat and customize your trailer
- Soft ergonomic adjustable handle
- Handle switches from left to right hand drive configuration - 1600 and 2000 lbs. models only
- Features E.I.S. - "Easy Install System"
- Patents pending
- Lifetime limited warranty



2-SPEED FEATURES



2 Speed Gear System



Low Speed



High Speed



FW16000101



FW20000101



FW32000101



F2® 1,600 LBS. SINGLE SPEED TRAILER WINCH

- Two piece corrosion resistant aluminum frame
- One piece corrosion resistant aluminum handle
- Dual gear drum operates smoothly
- Left or Right handed handle attachment
- 2-position handle adjusts from 6" to 7"
- Models available with or without 20' strap



E.I.S. - Easy Install System

F2® 2,000 LBS. SINGLE SPEED TRAILER WINCH

- One piece corrosion resistant aluminum frame
- One piece corrosion resistant aluminum handle
- Dual gear drum operates smoothly
- Center drive enclosed ratchet system
- User-friendly pull-turn knob to engage ratchet plunger pin
- Left or Right handed handle attachment
- 4-position handle adjusts from 6" to 9"
- Includes 20' strap with hook



Adjustable Handle

F2® 3,200 LBS. TWO SPEED TRAILER WINCH

- One piece corrosion resistant aluminum frame
- One piece corrosion resistant aluminum handle
- Dual gear drum operates smoothly
- Center drive enclosed ratchet
- Self-engaging one-handed system shifts from high to low speed
- User-friendly pull-turn knob to engage ratchet plunger pin
- 4-position handle adjusts from 6" to 9"
- Includes strap guide and 20' heavy duty strap with hook

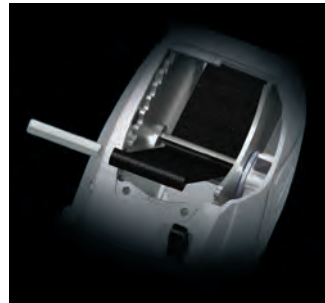

Hub Mounted Strap

F2® TRAILER WINCHES

Part No.	Capacity	Gear Ratio	Handle Length	Strap	Strap Included	Mounting Hardware Included	Finish	Packaging	Unit Wt. Lbs.
F2® SINGLE SPEED TRAILER WINCHES									
FW16000101	1,600	4.1:1	2 Position 6", 7"	20' x 2" w/Hook	YES	YES	Sharkskin™	Display Box	9.25
FW1600Z0301	1,600	4.1:1	2 Position 6", 7"	20' x 2" w/Hook	YES	YES	Sharkskin™	Bulk	8.7
FW20000101	2,000	5.1:1	4 Position 6", 7", 8", 9"	20' x 2" w/Hook	YES	YES	Sharkskin™	Display Box	6.7
FW20000301	2,000	5.1:1	4 Position 6", 7", 8", 9"	20' x 2" w/Hook	YES	YES	Sharkskin™	Bulk	6.7
F2® TWO SPEED TRAILER WINCHES									
FW32000101	3,200	5.1:1, 3.17:1	4 Position 6", 7", 8", 9"	20' x 2" Heavy Duty w/Hook	YES	YES	Sharkskin™	Display Box	15.7
FW32000301	3,200	5.1:1, 3.17:1	4 Position 6", 7", 8", 9"	20' x 2" Heavy Duty w/Hook	YES	YES	Sharkskin™	Bulk	15.7
REPLACEMENT PARTS									
FW3200S01	F2 Two Speed Replacement Sun Gear Kit								
500350	Top Cover for F2 FW1600, FW2000 & FW3200 Winches								
500351	Back Cover for F2 FW2000 & FW3200 Winches								
0133313S00	Winch Handle for F2 FW1600								
1596S01	Ratchet Repair Kit for F2 FW1600								

Patent Pending.



SINGLE SPEED TRAILER WINCHES

Our full line of Fulton single speed winches are designed to meet your toughest pulling demands. Our winches solid drum gear construction delivers smooth cranking & durability, and also feature a 2-way ratchet pawl with neutral feature, and ZMAX 600 clear zinc finish for superior corrosion resistance. For end user convenience, models are available with the strap and hook included. Our XLT® Series include stylized thermoplastic covers and come standard with the strap and hook included.



5 year limited warranty

CE Compliant



2-Way Ratchet Pawl

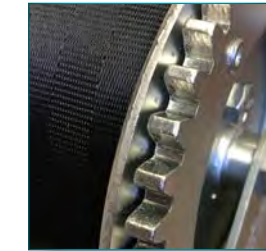

Solid Drum Gear Construction



• 600 hour salt spray rating per ASTM B117

SINGLE SPEED TRAILER WINCHES

Part No.	Capacity	Handle Length	Max. Mech. Adv**	Drum Storage			Recommended Strap Bolt Sizes	Strap Included	Packaging
				Rope	Cable	Strap			
142001	900	7"	39:1	36' x 1/4"	N/A	15' x 2"	1/4" x 2-1/2" Grade 5	NO	Litho Box
142002	900	7"	39:1	36' x 1/4"	N/A	15' x 2"	1/4" x 2-1/2" Grade 5	NO	Bulk
142003	900	7"	39:1	36' x 1/4"	N/A	15' x 2"	1/4" x 2-1/2" Grade 5	YES	Bulk
142006	900	6"	39:1	36' x 1/4"	N/A	12' x 2"	1/4" x 2-1/2" Grade 5	YES	Litho Box
142007	900	6"	39:1	36' x 1/4"	N/A	12' x 2"	1/4" x 2-1/2" Grade 5	YES	Bulk
142100	1,100	7"	43:1	30' x 5/16"	N/A	20' x 2"	1/4" x 2-1/2" Grade 5	NO	Litho Box
142101	1,100	7"	43:1	30' x 5/16"	N/A	20' x 2"	1/4" x 2-1/2" Grade 5	NO	Bulk
142102	1,100	7"	43:1	30' x 5/16"	N/A	20' x 2"	1/4" x 2-1/2" Grade 5	YES	Litho Box
142103	1,300	8"	49:1	30' x 5/16"	N/A	20' x 2"	1/4" x 2-1/2" Grade 5	NO	Litho Box
142104	1,300	8"	49:1	30' x 5/16"	N/A	20' x 2"	1/4" x 2-1/2" Grade 5	NO	Bulk
142320 (XLT)	1,400	8"	43:1	N/A	N/A	20' x 2"	5/16" x 2-1/2" Grade 5	YES	Bulk
142311	1,500	8"	43:1	N/A	N/A	20' x 2"	5/16" x 2-1/2" Grade 5	YES	Litho Box
142320 (XLT)	1,500	8"	43:1	N/A	N/A	20' x 2"	5/16" x 2-1/2" Grade 5	YES	Bulk
142200 (XLT)	1,500	8"	49:1	20' x 5/16"	N/A	20' x 2"	1/4" x 2-1/2" Grade 5	NO	Litho Box
142201	1,500	8"	49:1	20' x 5/16"	N/A	20' x 2"	1/4" x 2-1/2" Grade 5	NO	Bulk
142203	1,500	8"	49:1	20' x 5/16"	N/A	20' x 2"	1/4" x 2-1/2" Grade 5	YES	Litho Box
142204	1,500	8"	49:1	20' x 5/16"	N/A	20' x 2"	1/4" x 2-1/2" Grade 5	YES	Bulk
142208	1,500	8"	56:1	20' x 5/16"	N/A	20' x 2"	1/4" x 2-1/2" Grade 5	YES	Litho Box
142300	1,800	10"	62:1	20' x 7/16"	N/A	20' x 2"	3/8" x 2-3/4" Grade 5	NO	Litho Box
142301	1,800	10"	62:1	20' x 7/16"	N/A	20' x 2"	3/8" x 2-3/4" Grade 5	NO	Bulk
142305	1,800	10"	62:1	20' x 7/16"	N/A	20' x 2"	3/8" x 2-3/4" Grade 5	YES	Litho Box
142306	1,800	8"	62:1	20' x 7/16"	N/A	20' x 2"	3/8" x 2-3/4" Grade 5	YES	Bulk
142314 (XLT)	1,800	10"	62:1	N/A	N/A	20' x 2"	3/8" x 2-3/4" Grade 5	YES	Litho Box
142315 (XLT)	1,800	10"	62:1	N/A	N/A	20' x 2"	3/8" x 2-3/4" Grade 5	YES	Bulk

CE All Horizon Global single speed trailer winches are CE compliant. **Maximum Mechanical Advance - Based on first layer of recommended line on the drum. For maximum efficiency, use only the amount of line required.

SINGLE SPEED WINCH ACCESSORIES



501103



501207



WS20HD0200

Part No.	Description	Packaging
501103	Winch Handle, 6" Offset Packaged	Carded
501107	Winch Handle, 7" Offset Packaged	Carded
501106	Winch Handle, 8" Offset Packaged	Carded
501109	Winch Handle, 9" Offset Packaged	Bulk
501108	Winch Handle, 10" Offset Packaged	Carded
501110	Winch Handle, 10" Dogleg Packaged	Carded
501101	Winch Handle, 11" Offset Packaged	Carded
501201	Winch Strap and Hook - Nylon Web Winch Strap with Hook, 2" x 20', 2,600 lbs. Maximum Working Load	Bulk
501202	Winch Strap and Hook - Nylon Web Winch Strap with Hook, 2" x 20', 2,600 lbs. Maximum Working Load	Clam
501205	Winch Strap and Hook - Nylon Web Winch Strap with Hook, 2" x 20', 2,600 lbs. Maximum Working Load	Counter Display Box
501207	Winch Strap and Hook, 1.88" x 20'	Clam
501208	Personal Watercraft Winch Strap with Hook and Loop - Includes Loop Nylon Web Winch Strap with Hook, 2" x 12', 1,800 lbs. Maximum Working Load	Clam
501209	Personal Watercraft Winch Strap with Hook and Loop - Includes Loop Nylon Web Winch Strap with Hook, 2" x 12', 1,800 lbs. Maximum Working Load	Bulk
WS20HD0200	Heavy Duty Winch Strap with Hook - 2" x 20', 10,000 lbs. Minimum Breaking Strength, 4,000 lbs. Maximum Working Load	Bulk
WS20HD0600	Heavy Duty Winch Strap with Hook - 2" x 20', 10,000 lbs. Minimum Breaking Strength, 4,000 lbs. Maximum Working Load	Clam

TWO SPEED TRAILER WINCHES

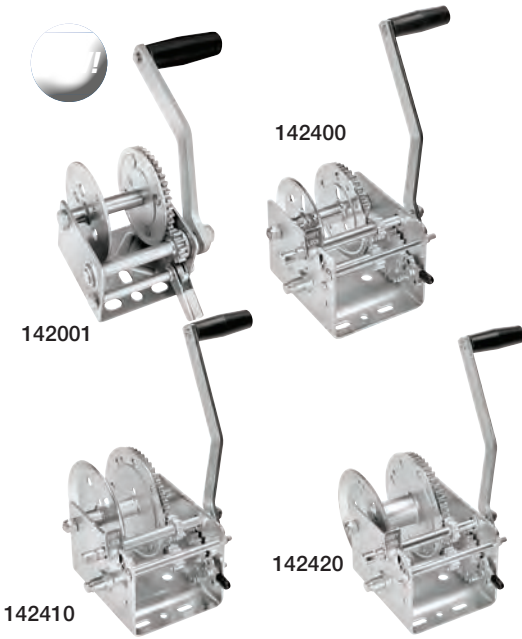

TWO SPEED TRAILER WINCHES



Make light work of heavy loads with Fulton brand two-speed winches. One fast speed for quick pull-in, a second low speed for increased mechanical advantage. Our shift lock design allows changing gears without moving the crank handle from shaft to shaft. Just lift the shift lock and slide the shaft into the desired gear position. Shift lock holds the shaft in gear. Neutral, free-wheel position allows quick line pay out without spinning the handle. Optional handbrake kit no. 501201 purchased separately and available for all two-speed winches and can be installed after the winch is mounted.

Our XLT® Series include stylized thermoplastic covers and come standard with the strap and hook included.

5 year limited warranty



• 600 hour salt spray rating per ASTM B117

CE Compliant

TWO SPEED TRAILER WINCHES

Part No.	Cap.	Handle Length	Max. Mech. Adv**	Drum Storage		Recommended Strap Bolt Sizes	Hub Size	Hand Brake	Strap Includ.	Cable Includ.	Pkg.
				Cable	Strap						
142400	2,000	10"	87:1	N/A	20' x 2"	N/A	1"	501210***	NO	N/A	Litho Box
142401	2,000	10"	87:1	N/A	20' x 2"	3/8" x 2-3/4" grade 5	1"	501210***	NO	N/A	Bulk
142403	2,000	10"	87:1	N/A	20' x 2"	3/8" x 2-3/4" grade 5	1"	501210***	YES	N/A	Bulk
142410	2,600	10"	108:1	N/A	20' x 2"	N/A	1"	501210***	NO	N/A	Litho Box
142412	2,600	10"	108:1	N/A	20' x 2"	N/A	1"	501210***	NO	N/A	Bulk
142415	2,600	10"	108:1	N/A	20' x 2"	3/8" x 2-3/4" grade 5	1"	501210***	YES	N/A	Litho Box
142416	2,600	10"	108:1	N/A	20' x 2"	3/8" x 2-3/4" grade 5	1"	501210***	YES	N/A	Bulk
142418 (XLT)	2,600	10"	108:1	N/A	20' x 2"	3/8" x 2-3/4" grade 5	1"	501210***	YES	N/A	Bulk
142419	2,600	6-1/4"	108:1	N/A	20' x 2"	3/8" x 2-3/4" grade 5	1"	501210***	YES	N/A	Bulk
142411	2,600	10"	108:1	N/A	20' x 2"	N/A	1"	Installed	NO	N/A	Litho Box
142414	2,600	10"	108:1	N/A	N/A	3/8" x 2-3/4" grade 5	1"	501210***	NO	N/A	Bulk
142420	3,200	10"	79:1	100' x 7/32"	N/A	Cable only	1-3/4"	501210***	N/A	NO	Litho Box
142421	3,200	10"	79:1	100' x 7/32"	N/A	Cable only	1-3/4"	501210***	N/A	NO	Bulk
142425 (XLT)	3,200	10"	79:1	N/A	20' x 2"	3/8" x 2-3/4" grade 5	1"	501210***	YES	N/A	Bulk
142423	3,200	10"	108:1	N/A	20' x 2"	3/8" x 2-3/4" grade 5	1"	No	YES	N/A	Bulk
142430	3,700	10"	102:1	90' x 7/32"	N/A	Cable only	1-3/4"	Included	N/A	NO	Litho Box

CE All Horizon Global single speed trailer winches are CE compliant. **Maximum Mechanical Advance - Based on first layer of recommended line on the drum. For maximum efficiency, use only the amount of line required. ***Brake Kit 501210 available as option not furnished. Only winches that are shown to accommodate steel cable should be used with steel cable. Cable keeper kits are included with the winches specifying steel cable. Winches rated for steel cable have a larger drum hub to reduce or lessen chance of kinking or fraying.



TWO SPEED WINCH ACCESSORIES



501108



WC325 0100



WS20HD0600

Part No.	Description	Packaging
501108	Winch Handle, 10" Offset Packaged	Carded
501110	Winch Handle, 10" Dogleg Packaged	Carded
501201	Winch Strap and Hook - Nylon Web Winch Strap with Hook, 2" x 20', 2,600 lbs. Maximum Working Load	Bulk
501202	Winch Strap and Hook - Nylon Web Winch Strap with Hook, 2" x 20', 2,600 lbs. Maximum Working Load	Clam
501205	Winch Strap and Hook - Nylon Web Winch Strap with Hook, 2" x 20', 2,600 lbs. Maximum Working Load	Counter Display Box
501207	Winch Strap and Hook, 1.88" x 20'	Clam
WS20HD0200	Heavy Duty Winch Strap with Hook - 2" x 20', 10,000 lbs. Minimum Breaking Strength, 4,000 lbs. Maximum Working Load	Bulk
WS20HD0600	Heavy Duty Winch Strap with Hook - 2" x 20', 10,000 lbs. Minimum Breaking Strength, 4,000 lbs. Maximum Working Load	Clam
WC325 0100	Winch Cable and Hook - 3/16" x 25' Galvanized Cable, 4,200 lbs. Breaking Strength	Clam
WC750 0100	Winch Cable and Hook - 7/32" x 50' Galvanized Cable, 5,600 lbs. Breaking Strength	Bagged

REPLACEMENT PARTS



501132



501133

Part No.	Description	Packaging
501132	Replacement Part, Ratchet Repair, 2-Speed - 142400, 142410, 142420	Bagged
501134	Replacement Part, Input Shaft / Bearing - 142400, 142410, 142420	Bagged
501210	Replacement Part, 2-Speed Hand Brake Kit, Includes Mounting Hardware	Bagged
501133	Replacement Part, Ratchet Repair - 142430	Bagged
501135	Replacement Part, Ratchet Spring, 2-Speed	Bagged



501135

Notes:

1. Winch mounting hardware sold separately. Refer to instruction sheet for recommended bolt size and grade.
2. Fulton brand two-speed winches are designed for boat trailer and other pulling applications, which require the freewheeling feature of ratchet type winches. If moving loads requiring vertical lifting, or positive load control in both directions, choose a Fulton brake winch.
3. All Fulton brand winches are rated on the first layer of recommended rope, strap, or cable. The winch load capacity must be derated as additional layers are used. Derate the capacity 10% per additional layer of rope, strap, or cable.
4. Fulton brand winches are NOT designed to be human hoists and should never be operated when there are persons on, around, or under the load being moved.

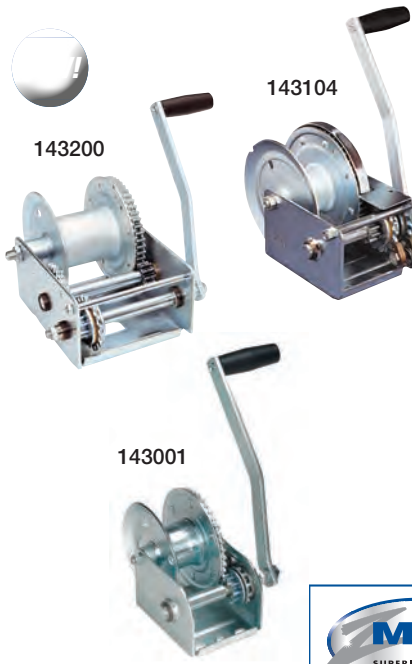

CE Compliant



INDUSTRY LEADING CORROSION PROTECTION

• 600 hour salt spray rating per ASTM B117

BRAKE WINCHES

Fulton self-activating automatic brake winches hold the load securely when the crank handle is released. Popular applications include construction light towers, grain augers, manual fork lifts, and boat lifts. Drum hubs are 10 times the recommended cable size to maximize cable life.

For especially demanding applications select models feature covered drums and gear trains, along with a dual ratchet system. 5 year limited warranty

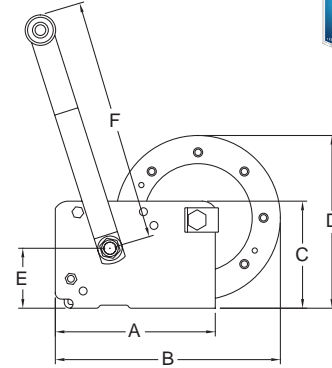

Capacity	A	B	C	D	E	F
1,000 lbs.	5.25"	7.46"	3.69"	5.89"	1.90"	11.00"
1,500 lbs.	6.56"	9.23"	4.39"	7.08"	2.46"	11.00"
2,500 lbs.	8.63"	11.13"	5.60"	7.13"	2.08"	11.00"

Contact Horizon Representative for mounting hole information.

BRAKE WINCHES

Part No.	Max. Rated Line Pull		Max. Cable Size Data (7 x 19 Galvanized Aircraft Cable)			Mechanical Data					
	1st Layer	Full Drum	Diameter	Drum Storage	Test Strength	Gear Ratio	Handle Length	Drum Hub Dia.	Covered Gears	Cable Included	Packaging
143001	1,000 lbs. 454 kg	500 lbs. 227 kg	7/32" (5.5 mm)	50 ft. 15 m	5,600 lbs. 2540 kg	4.1:1	11" 27.9 cm	2-1/4" 57 mm	NO	NO	Litho Box
143002	1,000 lbs. 454 kg	500 lbs. 227 kg	7/32" (5.5 mm)	50 ft. 15 m	5,600 lbs. 2540 kg	4.1:1	11" 27.9 cm	2-1/4" 57 mm	NO	NO	Bulk
143005	1,000 lbs. 454 kg	500 lbs. 227 kg	7/32" (5.5 mm)	50 ft. 15 m	5,600 lbs. 2540 kg	4.1:1	11" 27.9 cm	2-1/4" 57 mm	YES	NO	Ind. Box
143006	1,000 lbs. 454 kg	500 lbs. 227 kg	7/32" (5.5 mm)	50 ft. 15 m	5,600 lbs. 2540 kg	4.1:1	11" 27.9 cm	2-1/4" 57 mm	YES	NO	Bulk
143100	1,500 lbs. 680 kg	700 lbs. 318 kg	1/4" (6 mm)	70 ft. 21 m	7,000 lbs. 3175 kg	5.1:1	11" 27.9 cm	2-1/2" 63 mm	NO	NO	Litho Box
143101	1,500 lbs. 680 kg	700 lbs. 318 kg	1/4" (6 mm)	70 ft. 21 m	7,000 lbs. 3175 kg	5.1:1	11" 27.9 cm	2-1/2" 63 mm	NO	NO	Bulk
143104	1,500 lbs. 680 kg	700 lbs. 318 kg	1/4" (6 mm)	70 ft. 21 m	7,000 lbs. 3175 kg	5.1:1	11" 27.9 cm	2-1/2" 63 mm	YES	NO	Ind. Box
143105	1,500 lbs. 680 kg	700 lbs. 318 kg	1/4" (6 mm)	70 ft. 21 m	7,000 lbs. 3175 kg	5.1:1	11" 27.9 cm	2-1/2" 63 mm	YES	NO	Bulk
143200	2,500 lbs. 1134 kg	1,500 lbs. 680 kg	5/16" (8 mm)	70 ft. 21 m	9,800 lbs. 4445 kg	15.8:1	11" 27.9 cm	3-1/8" 79 mm	NO	NO	Litho Box
143201	2,500 lbs. 1134 kg	1,500 lbs. 680 kg	5/16" (8 mm)	70 ft. 21 m	9,800 lbs. 4445 kg	15.8:1	11" 27.9 cm	3-1/8" 79 mm	NO	NO	Bulk

Only winches that are shown to accommodate steel cable should be used with steel cable. Cable keeper kits are included with the winches specifying steel cable. Winches rated for steel cable have a larger drum hub to reduce or lessen chance of kinking or fraying.

CE All Horizon Global brake winches are CE compliant.

Notes:

1. Fulton brand brake winches meet ASAE S361:3 standards.
2. Winch mounting hardware sold separately. Refer to instruction sheet for recommended bolt size and grade.
3. All Fulton brand winches are rated on the first layer of recommended rope, strap, or cable. The winch must be derated as additional layers are used. Derate the capacity 10% per additional layer of rope, strap, or cable.
4. Fulton brand winches are NOT designed to be human hoists and should never be operated when there are persons on, around, or under the load being moved.



BRAKE WINCHES



- Self Activating Automatic Brake
- Passes all applicable SAE and ASAE standards
- Enlarged drum size to extend cable life
- Solid Gear construction
- Covered Braking System
- CE Compliant

BRAKE WINCHES

Part No.	Capacity	Gear Ratio	Cable Capacity	Cable included	Packaging
KR10000301	1,000 lbs.	3.5:1	50 ft., 7/32" Dia.	NO	Boxed
KR15000301	1,500 lbs.	5.1:1	50 ft., 7/32" Dia.	NO	Boxed



BRAKE WINCH ACCESSORIES

Part No.	Description	Packaging
501101	Winch Handle, 11" Offset Packaged	Carded
WC325 0100	Winch Cable and Hook - 3/16" x 25' Galvanized Cable, 4,200 lbs. Breaking Strength	Clam
WC750 0100	Winch Cable and Hook - 7/32" x 50' Galvanized Cable, 5,600 lbs. Breaking Strength	Bagged



REPLACEMENT PARTS

Part No.	Description	Packaging
501130	Replacement Part, Winch Cover Kit - 143104, 143105	Bagged
501115	Replacement Part, Friction Disc - 143100, 143101, 143104, 143105	Bagged
501118	Replacement Part, Pinion Shaft - 143100, 143101, 143104, 143105	Bagged
501116	Replacement Part, Pinion Shaft - 143005, 143006, 143104, 143105	Bagged
501121	Replacement Part, Pinion Shaft / Gear - 143200, 143201	Bagged
501131	Replacement Part, Inter Shaft - 143200, 143201	Bagged
501122	Replacement Part, Friction / Brake Disc - 143001, 143002, 143005, 143006	Bagged
500357	Replacement Part, Handle Kit - KR10000301, KR15000301	Bagged
500366	Replacement Part, Cable Keeper - KR10000301, KR15000301	Boxed
501001	Replacement Part, Cable Keeper - 143001, 143002, 143005, 143006, 143100, 143101, 143104, 143105, 143200, 143201	Clam Shell
501117	Replacement Part, Ratchet Repair - 143100, 143101, 143104, 143105	Bagged
501125	Replacement Part, Ratchet Repair - 143001, 143002, 143005, 143006	Bagged
501124	Replacement Part, Winch Cover Kit - 143005, 143006	Bagged





500600

UTILITY DUTY WINCHES

- 9,000 lbs. - 12,000 lbs. capacities
- Power in and power out for powerful retraction and rapid rope payout
- High-torque motor for a higher pull at a lower amp
- 3-stage planetary gearbox for reliable performance in tough conditions
- Clutch lever, easy transition between gear engagement & free spooling
- Dual brakes include both automatic load-holding mechanical brake and slip-free motor dynamic brake for sure, confident control without slippage
- Integrated contactor assembly
- Circuit breakers automatically shut off the winch to prevent motor overheating (2500, 3500, 4500)
- Standard compliance with **CE** Machinery Directive 2006/42/EC and **CE** Electromagnetic Compatibility Directive 2004/108/EC

UTILITY DUTY WINCHES

Part No.	Motor	Rated Line Pull	Rope Dia.	Winch Weight	Gross Weight	Rope Included	Remote Included
500600	12V, 4.63 KW, 5.8 HP	9,000 lbs. (4082 kg)	21/64" (8.3 mm)	84.4 lb (38.3 kg)	88.85 lb (40.3 kg)	Yes	Yes
500601	12V, 5.4 KW, 7.2 HP	12,00 lbs. (5443 kg)	13/32" (10.2mm)	96.6 lb (43.8 kg)	101 lb (45.8 kg)	Yes	Yes

DC12.0 12,000 LB.

12000_{lb}
LIFT CAPACITY

LIMITED 1 YEAR WARRANTY

500601	
MOTOR	12V, 5.4 KW, 7.2 HP
ROPE DIAMETER	13/32" (10.2 mm)
WINCH WEIGHT WITH ROPE	96.6 lb. (43.8 kg)
GROSS WEIGHT WITH ROPE	101 lb. (45.8 kg)
INCLUDED ROPE	13/32" x 83.7' (10.2 mm x 25.5 m)

DC9.0 9,000 LB.

9000_{lb}
LIFT CAPACITY

LIMITED 1 YEAR WARRANTY

500600	
MOTOR	12V, 4.63 kw, 5.8 HP
ROPE DIAMETER	21/64" (8.3 mm)
WINCH WEIGHT WITH ROPE	84.4 lb. (38.3 kg)
GROSS WEIGHT WITH ROPE	88.85 lb. (40.3 kg)
INCLUDED ROPE	21.64" x 95' (8.3 mm x 29 m)

*Limited lifetime warranty on mechanical parts. One year warranty on electrical components.



500402



UTILITY DUTY WINCHES

- 2,500 lbs. - 4,500 lbs. capacities
- Power in and power out for powerful retraction and rapid rope payout
- High-torque motor for a higher pull at a lower amp
- 3-stage planetary gearbox for reliable performance in tough conditions
- Clutch lever, easy transition between gear engagement & free spooling
- Dual brakes include both automatic load-holding mechanical brake and slip-free motor dynamic brake for sure, confident control without slippage
- Integrated contactor assembly
- Circuit breakers automatically shut off the winch to prevent motor overheating (2500, 3500, 4500)
- Standard compliance with **CE** Machinery Directive 2006/42/EC and **CE** Electromagnetic Compatibility Directive 2004/108/EC

UTILITY DUTY WINCHES

Part No.	Motor	Rated Line Pull	Rope Dia.	Winch Weight	Gross Weight	Rope Included	Remote Included
500400	12V DC, 600 W, 0.8 HP	2,500 lbs. (1133 kg)	3/16" (4.8mm)	27.44 lbs. (12 kg)	37.2 lbs. (16 kg)	Yes	Yes
500401	12V DC, 900 W, 1.2 HP	3,500 lbs. (1587 kg)	7/32" (5.5mm)	27.44 lbs. (12 kg)	37.2 lbs. (16 kg)	Yes	Yes
500402	12V DC, 1200 W, 1.6 HP	4,500 lbs. (2041 kg)	1/4" (6.3mm)	27.44 lbs. (12 kg)	37.2 lbs. (16 kg)	Yes	Yes

DC4.5 4,500 LB.

4500 lb
LIFT CAPACITY

LIMITED LIFETIME WARRANTY

500402	
MOTOR	12V DC, 1200 W, 1.6 HP
ROPE DIAMETER	1/4" (6.3 mm)
WINCH WEIGHT WITH ROPE	27.44 lb. (12 kg)
GROSS WEIGHT WITH ROPE	37.2 lb. (16 kg)
INCLUDED ROPE	3/16" x 50' (4.8 mm x 15.24 m)

DC3.5 3,500 LB.

3500 lb
LIFT CAPACITY

LIMITED LIFETIME WARRANTY

500401	
MOTOR	12V DC, 900 W, 1.2 HP
ROPE DIAMETER	7/32" (5.5 mm)
WINCH WEIGHT WITH ROPE	27.44 lb. (12 kg)
GROSS WEIGHT WITH ROPE	37.2 lb. (16 kg)
INCLUDED ROPE	7/32" x 50' (5.5 mm x 15.24 m)

DC2.5 2,500 LB.

2500 lb
LIFT CAPACITY

LIMITED LIFETIME WARRANTY

500400	
MOTOR	12V DC, 600 W, 0.8 HP
ROPE DIAMETER	3/16" (4.8 mm)
WINCH WEIGHT WITH ROPE	27.44 lb. (12 kg)
GROSS WEIGHT WITH ROPE	37.2 lb. (16 kg)
INCLUDED ROPE	1/4" x 50' (6.3 mm x 15.25 m)

*Limited lifetime warranty on mechanical parts. One year warranty on electrical components.



500403



500423

HEAVY DUTY WINCHES

- 6,000 lbs. - 18,000 lbs. capacities
- Patented automatic, full load Cone Brake Structure (CBS) uses “brake outside the drum” technology to rapidly disperse heat, protecting the winch and the rope.
- Rugged, quiet, hardened steel 3-stage planetary gear train for reliable, durable performance in tough conditions and maximum mechanical efficiency
- Heavy duty sealed contactor for sound, waterproof protection
- Durable heavy duty motor delivers superior torque output & faster line speed
- Thermometric sensor provides overheating indication
- Industrial grade waterproof remote includes LED overheating indicator
- Pull-and-turn T-handle clutch lever for easy transition between gear engagement & free spooling
- Standard compliance with **CE** Machinery Directive 2006/42/EC and **CE** Electromagnetic Compatibility Directive 2004/108/EC
- SAE J706 Compliant



(with rope)



(without rope)

HEAVY DUTY WINCHES (WITH ROPE)

Part No.	Motor	Rated Line Pull	Gear Ratio	Drum Size	Rope Dia.	Winch Weight	Gross Weight	Rope Included	Remote Included
500423	12V DC, 2390 W, 3.2 HP	6,000 lbs. (2722 kg)	216:1	2.5" x 4.9" (63.5mm x 125.5mm)	9/32" (7.1mm)	33.2 lbs. (15.1 kg)	44 lbs. (20kg)	Yes	No
500424	12V DC, 3430 W, 4.6 HP	9,000 lbs. (4082 kg)	156:1	2.5" x 9" (63.5mm x 229mm)	3/8" (9.5mm)	53 lbs. (24.1 kg)	78 lbs. (35.5 kg)	Yes	No
500426	12V DC, 3430 W, 4.6 HP	12,000 lbs. (5443 kg)	211:1	2.5" x 9" (63.5mm x 229mm)	3/8" (9.5mm)	59 lbs. (26.8 kg)	88 lbs. (40 kg)	Yes	No

HEAVY DUTY WINCHES (WITHOUT ROPE)

Part No.	Motor	Rated Line Pull	Gear Ratio	Drum Size	Rope Dia.	Winch Weight	Gross Weight	Rope Included	Remote Included
500403	12V DC, 2390 W, 3.2 HP	6,000 lbs. (2722 kg)	216:1	2.5" x 4.9" (63.5mm x 125.5mm)	9/32" (7.1mm)	33.2 lbs. (15.1 kg)	44 lbs. (20kg)	No	No
500404	12V DC, 3430 W, 4.6 HP	9,000 lbs. (4082 kg)	156:1	2.5" x 9" (63.5mm x 229mm)	3/8" (9.5mm)	53 lbs. (24.1 kg)	78 lbs. (35.5 kg)	No	No
500405	12V DC, 3430 W, 4.6 HP	12,000 lbs. (5443 kg)	211:1	2.5" x 9" (63.5mm x 229mm)	3/8" (9.5mm)	59 lbs. (26.8 kg)	88 lbs. (40 kg)	No	No
500406	12V DC, 4180 W, 5.6 HP	12,000 lbs. (5443 kg)	261:1	3.5" x 8.1" (89mm x 206mm)	3/8" (9.5mm)	88 lbs. (40 kg)	118 lbs. (53.6 kg)	No	No
500407	12V DC, 4180 W, 5.6 HP	15,000 lbs. (6804 kg)	315:1	3.5" x 8.1" (89mm x 206mm)	7/16" (11.1mm)	90 lbs. (41 kg)	120 lbs. (54.5 kg)	No	No
500408	24V DC, 4474 W, 6.0 HP	18,000 lbs. (8181 kg)	315:1	3.5" x 7.6" (89mm x 192mm)	1/2" (12.7mm)	93 lbs. (42.3 kg)	124 lbs. (56.4 kg)	No	No

HEAVY DUTY WINCHES

DC6000 6,000 LB.

6000^{lb}
LIFT CAPACITY

LIMITED LIFETIME WARRANTY



500403	
MOTOR	12V DC, 2390 W, 3.2 HP
RATED LINE PULL	6,000 lb (2,722 kg)
GEAR RATIO	216:1
DRUM SIZE	2.5" x 4.9" (63.5 x 125.5 mm)
RECOMMENDED ROPE SIZE x LENGTH	9/32" x 80' (7.1 mm x 24 m)
RECOMMENDED ROPE TYPE	Galvanized aircraft A7 x 19
WINCH WEIGHT	33.2 lb (15.1 kg)
GROSS WEIGHT	44 lb (20 kg)

DC9000 9,000 LB.

9000^{lb}
LIFT CAPACITY

LIMITED LIFETIME WARRANTY



500404	
MOTOR	12V DC, 3,430 W, 4.6 HP
RATED LINE PULL	9,000 lb (4,082 kg)
GEAR RATIO	156:1
DRUM SIZE	2.5" x 9" (63.5 x 229 mm)
RECOMMENDED ROPE SIZE x LENGTH	3/8" x 82' (9.5 mm x 25 m)
RECOMMENDED ROPE TYPE	Galvanized aircraft A7 x 19
WINCH WEIGHT	53 lb (24.1 kg)
GROSS WEIGHT	78 lb (35.5 kg)

DC1200L 12,000 LB.

12000^{lb}
LIFT CAPACITY

LIMITED LIFETIME WARRANTY



50405	
MOTOR	12V DC, 3,430 W, 4.6 HP
RATED LINE PULL	12,000 lb (5,443 kg)
GEAR RATIO	211:1
DRUM SIZE	2.5" x 9" (63.5 x 229 mm)
RECOMMENDED ROPE SIZE x LENGTH	3/8" x 82' (9.5 mm x 25 m)
RECOMMENDED ROPE TYPE	Galvanized aircraft A7 x 19
WINCH WEIGHT	59 lb (26.8 kg)
GROSS WEIGHT	88 lb (40 kg)

DC12000 12,000 LB.

12000^{lb}
LIFT CAPACITY

LIMITED LIFETIME WARRANTY



500406	
MOTOR	12V DC, 4,180 W, 5.6 HP
RATED LINE PULL	12,000 lb (5,443 kg)
GEAR RATIO	261:1
DRUM SIZE	3.5" x 8.1" (89 x 206 mm)
RECOMMENDED ROPE SIZE x LENGTH	3/8" x 125' (9.5 mm x 38 m)
RECOMMENDED ROPE TYPE	Galvanized aircraft A7 x 19
WINCH WEIGHT	88 lb (40 kg)
GROSS WEIGHT	118 lb (53.6 kg)

DC15000 15,000 LB.

15000^{lb}
LIFT CAPACITY

LIMITED LIFETIME WARRANTY



500407	
MOTOR	12V DC, 4,180 W, 5.6 HP
RATED LINE PULL	15,000 lb (6,804 kg)
GEAR RATIO	315:1
DRUM SIZE	3.5" x 8.1" (89 x 206 mm)
RECOMMENDED ROPE SIZE x LENGTH	7/16" x 90' (11.1 mm x 27 m)
RECOMMENDED ROPE TYPE	6 x 29 IWRC
WINCH WEIGHT	90 lb (41 kg)
GROSS WEIGHT	120 lb (54.5 kg)

DC18000 18,000 LB.

18000^{lb}
LIFT CAPACITY

LIMITED LIFETIME WARRANTY



500408	
MOTOR	24V DC, 4,474 W, 6.0 HP
RATED LINE PULL	18,000 lb (8,188 kg)
GEAR RATIO	315:1
DRUM SIZE	3.5" x 7.6" (89 x 192 mm)
RECOMMENDED ROPE SIZE x LENGTH	1/2" x 82' (12.7 mm x 25 m)
RECOMMENDED ROPE TYPE	6 x 29 IWRC
WINCH WEIGHT	93 lb (42.3 kg)
GROSS WEIGHT	124 lb (56.4 kg)

*Limited lifetime warranty on mechanical parts. One year warranty on electrical components.



500415

HYDRAULIC WINCHES

BULLDOG™ Hydraulic Winches are cost effective, extremely powerful, reliable, lightweight, and flexible winches designed for professional and commercial use. They're hard-working winches ready for rescue and recovery operations in tough situations.

- 8,000 lbs. - 15,000 lbs. capacities
- Fast and variable recovery speeds save time
- Efficient, high-torque motor provides consistent power
- 2-stage planetary gear train delivers greater pulling force
- Ergonomic pull-and-turn T-handle clutch lever for easy transition between gear engagement and free spooling
- Dual brakes include both drag brake and over-center valve for sure, confident control
- EN 14492-1 supported: 10:1 D/d ratio and 2:1 wire rope strength for high-demand use
- Meets SAE J706 (revised 8/2003), CE Machinery Directive 2006/42/EC, and EN 14492-1:2006 Power Driven Winches

HYDRAULIC WINCHES

Part No.	Motor	Rated Line Pull	Gear Ratio	Drum Size	Rope Dia.	Winch Weight	Gross Weight	Strap Included	Remote Included
500413	4.7 in3 / rev (77.8 cm3 / rev)	8,000 lbs. (3630 kg)	16:1	3.5" (90mm)	3/8" (9.5mm)	82.7 lbs. (37.5 kg)	99.9 lbs. (45.3 kg)	No	No
500414	7.6 in3 / rev (125 cm3 / rev)	12,000 lbs. (5440 kg)	16:1	4" (102mm)	1/2" (12.7mm)	81.4 lbs. (37 kg)	102.5 lbs. (72 kg)	No	No
500415	7.6 in3 / rev (125 cm3 / rev)	15,000 lbs. (6800 kg)	19.4:1	4" (102mm)	1/2" (12.7mm)	158.7 lbs. (72 kg)	194 lbs. (88 kg)	No	No

HW15000 15,000 LB.



15000lb
LIFT
CAPACITY

LIMITED
LIFETIME
WARRANTY

500415

OPERATION PRESSURE	2,175 psi / 150 bar
MAX OIL FLOW	15.9 g / min (60 L / min)
HYDRAULIC MOTOR	7.6 in ³ / rev (125 cm ³ / rev)
GEAR RATIO	19.4:1
DRUM BARREL DIAMETER	4" (102 mm)
DRUM FLANGE DIAMETER	9.9" (252 mm)
DISTANCE BETWEEN FLANGES	10" (255 mm)
WIRE ROPE RECOMMENDED**	1/2" x 165' (12.7 mm x 50.3 m), 1,960 N / mm ² (EIPS) grade
WINCH WEIGHT WITHOUT ROPE	158.7 lb / 72 kg
GROSS WEIGHT	194 lb / 88 kg

HW12000 12,000 LB.



12000lb
LIFT
CAPACITY

LIMITED
LIFETIME
WARRANTY

500414

OPERATION PRESSURE	2,175 psi / 150 bar
MAX OIL FLOW	15.9 g / min (60 L / min)
HYDRAULIC MOTOR	7.6 in ³ / rev (125 cm ³ / rev)
GEAR RATIO	16:1
DRUM BARREL DIAMETER	4" (102 mm)
DRUM FLANGE DIAMETER	7.9" (201.5 mm)
DISTANCE BETWEEN FLANGES	10" (255 mm)
WIRE ROPE RECOMMENDED**	1/2" x 82' (12.7 mm x 25), 1,960 N / mm ² (EIPS) grade
WINCH WEIGHT WITHOUT ROPE	81.4 lb / 37 kg
GROSS WEIGHT	102.5 lb / 46.6 kg

HW8000 8,000 LB.



8000lb
LIFT
CAPACITY

LIMITED
LIFETIME
WARRANTY

500413

OPERATION PRESSURE	2,175 psi / 150 bar
MAX OIL FLOW	15.9 g / min (60 L / min)
HYDRAULIC MOTOR	4.7 in ³ / rev (77.8 cm ³ / rev)
GEAR RATIO	16:1
DRUM BARREL DIAMETER	3.5" (90 mm)
DRUM FLANGE DIAMETER	7.9" (201.5 mm)
DISTANCE BETWEEN FLANGES	10" (255 mm)
WIRE ROPE RECOMMENDED**	3/8" x 131' (9.5 mm x 40 m) 1,960 N / mm ² (EIPS) grade
WINCH WEIGHT WITHOUT ROPE	82.7 lb / 37.5 kg
GROSS WEIGHT	99.9 lb / 45.3 kg

*Limited lifetime warranty on mechanical parts. One year warranty on electrical components.



500412



ELECTRIC HOISTS

- 650 lbs. - 1,200 lbs. capacities
- Lightweight and compact design
- Sealed permanent magnet motor
- Equipped with patented mechanical cone brake with permanent dynamic motor brakes for controlled lowering and lifting
- Full metal 3-stage planetary gear train
- Submersible sealed contactor handles high amps and allows for longer duty cycle
- CE Compliant
- Complies with SAE J706
- Limited Lifetime on Mechanical and 1 Year Warranty on Electrical Components

ELECTRIC HOISTS

Part No.	Motor	Rated Line Pull	Gear Ratio	Drum Size	Rope Dia.	Winch Weight	Gross Weight	Strap Included	Remote Included
500410	12V DC, 800 W, 1.0 HP	650 lbs. (295 kg)	138.5:1	2.4" x 3.0" (61mm x 76mm)	9/64" (3.6mm)	17 lbs. (7.7 kg)	25.6 lbs. (11.6 kg)	No	Switch
500411	12V DC, 800 W, 1.0 HP	800 lbs. (362 kg)	191:1	2.7" x 4.7" (69mm x 119mm)	5/32" (4mm)	18.3 lbs. (8.3 kg)	26.9 lbs. (12.2 kg)	No	Switch
500412	12V DC, 900 W, 1.2 HP	1200 lbs. (544 kg)	216:1	3.5" x 2.9" (89mm x 74mm)	3/16" (4.8mm)	33.7 lbs. (15.3 kg)	44.5 lbs. (20.2 kg)	No	Switch

DCH1200 1,200 LB.

1200^{lb}
LIFT
CAPACITY

LIMITED
LIFETIME
WARRANTY

500412	
MOTOR	900 w / 1.2 hp 12V
RATED LINE LIFT	1,200 lb / 544 kg
GEAR RATIO	216:1
DRUM SIZE	3.5" x 2.9" (89mm x 74mm)
HOIST WEIGHT	33.7 lb / 15.3 kg
GROSS WEIGHT	44.5 lb / 20.2 kg
WIRE ROPE**	3/16" x 60' (4.8mm x 18.3m) A7 x 19 Galvanized Aircraft Cable
BRAKE	Both mechanical cone brake and permanent motor dynamic brakes
CONTROL	Handheld pendant switch

DCH800 800 LB.

800^{lb}
LIFT
CAPACITY

LIMITED
LIFETIME
WARRANTY

500411	
MOTOR	800 w / 1.0 hp 12V
RATED LINE LIFT	800 lb / 362 kg
GEAR RATIO	191:1
DRUM SIZE	2.7" x 4.7" (69mm x 119mm)
HOIST WEIGHT	18.3 lb / 8.3 kg
GROSS WEIGHT	26.9 lb / 12.2 kg
WIRE ROPE**	5/32" x 60' (4mm x 18.3m) A7 x 19 Galvanized Aircraft Cable
BRAKE	Mechanical spring applied and permanent motor dynamic brake together
CONTROL	Handheld pendant switch

DCH650 650 LB.

650^{lb}
LIFT
CAPACITY

LIMITED
LIFETIME
WARRANTY

500410	
MOTOR	800 w / 1.0 hp 12V
RATED LINE LIFT	650 lb / 295 kg
GEAR RATIO	138.5:1
DRUM SIZE	2.4" x 3.0" (61mm x 76mm)
HOIST WEIGHT	17 lb / 7.7 kg
GROSS WEIGHT	25.6 lb / 11.6 kg
WIRE ROPE**	9/64" x 60' (3.6mm x 18.3m) A7 x 19 Galvanized Aircraft Cable
BRAKE	Mechanical spring applied and permanent motor dynamic brakes together
CONTROL	Handheld pendant switch

*Limited lifetime warranty on mechanical parts. One year warranty on electrical components.



500526 / 500527



500528 / 500529



500530

WINCH REMOTES

Part No.	Description	Packaging
500526	Electric Winch Wireless Remote, 6 Pin	Carton
500527	Electric Winch Wireless controller, 3-pin	Carton
500528	3-Pin Wired Remote	Carton
500529	3-Pin Utility Wired Remote	Carton
500530	6-Pin Wired Remote	Carton



6495



6985

WINCH ACCESSORIES

Part No.	Description
6495	Winch Mounting Plate, for 9K Winches only
6985	Handle Grip for #6980 Handle Kit
500516	<input type="radio"/> Electric Winch Accessory, 9/32" x 80' Wire Rope
500520	<input type="radio"/> Electric Winch Accessory, Galvanized Aircraft A7x19, 3/8" x 82'
500522	<input type="radio"/> Electric Winch Accessory, Galvanized Aircraft A7x19, 3/8" x 125' Wire Rope



500524 / 500525



500534



500532 / 500533



500536



500539 / 500540



500538

WINCH REPLACEMENT PARTS

Part No.	Description	Packaging
500524	<input type="radio"/> Replacement Part, Hawse Fairlead 112MM for 6K Electric Winches	Boxed
500525	<input type="radio"/> Replacement Part, Hawse Fairlead 184MM for 9K & 12K Electric Winches	Boxed
500532	<input type="radio"/> Replacement Part, Tie Rod Kit for 6K Electric Winches	Bagged
500533	<input type="radio"/> Replacement Part, Tie Rod Kit for 9K & 12K Electric Winches	Bagged
500534	<input type="radio"/> Replacement Part, Tie Rod Kit for 12K - 18K Electric Winches	Bagged
500536	<input type="radio"/> Replacement Part, Cable Tensioner for 12K - 15K Electric Winches	Bagged
500537	<input type="radio"/> Replacement Part, Cable Tensioner for 18k Electric Winches	Bagged
500538	<input type="radio"/> Replacement Part, Cable Tensioner for 8K - 15K Hydraulic Winches	Bagged
500539	<input type="radio"/> Replacement Part, Roller Fairlead 63mm	Boxed
500540	<input type="radio"/> Replacement Part, Roller Fairlead 190mm	Boxed
500541	<input type="radio"/> Replacement Part, Roller Fairlead 210mm	Boxed
500542	<input type="radio"/> Replacement Part, Roller Fairlead 180mm	Boxed
500544	<input type="radio"/> Replacement Part, Roller Fairlead 245mm for Hydraulic Winches	Boxed
500545	<input type="radio"/> Replacement Part, Electric Contactor Kit for 6K Electric Winches	Boxed
500546	<input type="radio"/> Replacement Part, Electric Contactor Kit for 9K-15K Electric Winches	Boxed
500547	<input type="radio"/> Replacement Part, Electric Contactor Kit for 12K-18K Electric Winches	Boxed
500549	<input type="radio"/> Recovery Damper for Hydraulic Winches	Boxed
500550	<input type="radio"/> Replacement Part, Wire Rope Kit, 3/16"X50' for Electric Winches	Boxed
500551	<input type="radio"/> Replacement Part, Wire Rope Kit 7/32" x 50' for #500401	Boxed
500552	<input type="radio"/> Replacement Part, Wire Rope Kit 1/4" x 50' for #500402	Boxed



500541 / 500542



500544



500545



500546



500549

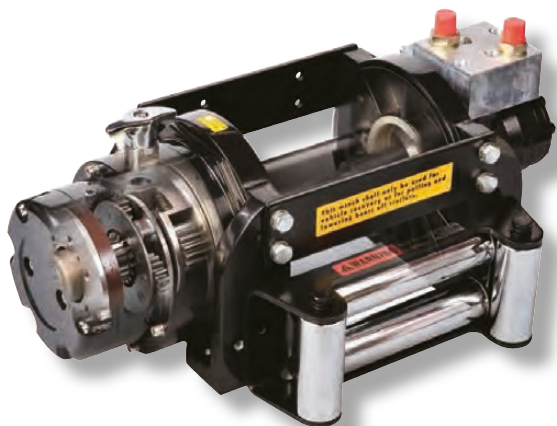

ACCESSORY & REPLACEMENT PART SELECTION CHART

PN	PRODUCT																	
		6 Pin Wireless Remote	3 Pin Wireless Remote	3 Pin Wired Remote Replacement	3 Pin Wired Remote Replacement	6 Pin Wired Remote Replacement	Heavse Fairlead	Heavse Fairlead	Replacement Tie Rod Kit	Replacement Tie Rod Kit	Replacement Tie Rod Kit	Cable Tensioner	Roller Fairlead	Roller Fairlead	Roller Fairlead	Roller Fairlead	Replacement Contactor	Replacement Contactor
		PN 500526	PN 500527	PN 500528	PN 500529	PN 500530	PN 500524	PN 500525	PN 500532	PN 500533	PN 500534	PN 500536	PN 500539	PN 500540	PN 500541	PN 500542	PN 500545	PN 500546
500400	DC2.5		•		•								•					
500401	DC3.5		•		•								•					
500402	DC4.5		•		•								•					
500403	DC6000 without rope		•	•			•		•					•			•	
500404	DC9000 without rope	•					•		•						•			•
500405	DC12000FFM without rope	•					•		•						•			•
500406	DC12000 without rope	•					•				•	•				•		•
500407	DC15000 without rope	•					•				•	•				•		•
500408	DC18000 without rope	•					•				•	•				•		•
500423	DC6000 with rope		•	•			•		•					•			•	
500424	DC9000 with rope	•					•		•						•			•
500426	DC12000 with rope	•					•				•	•			•			•
500410	DCH650		•														•	
500411	DCH800		•														•	
500412	DCH1200		•														•	

WESBAR® LIGHT UP YOUR LIFESTYLE



VEHICLE ILLUMINATION

LED TRAILER TAIL LIGHTS

LED Module Kits.	3
LED Single / Narrow Tail Lights.	4
LED Surface Mount Tail Lights.	5
LED Recessed Tail Lights.	5-6
Waterproof LED Tail Lights.	7-10
Submersible LED Tail Lights.	10

INCANDESCENT TRAILER TAIL LIGHTS

Single Tail Lights.	11
Wrap-Around Clearance / Side Marker Lights.	11
Recessed Double Tail Lights.	12
Recessed Triple Tail Lights.	12-13
Surface Mount Tail Lights.	14
Combination Tail Lights.	15
Tow Light Kit / Pedestal Mount Tail Lights	16
Sealed Recessed Tail Lights.	17
Waterproof Tail Lights.	17-18
Submersible Tail Lights.	19-20

AUXILIARY LIGHTING

LED Work Lights.	21
Waterproof Launch Lights.	22
Waterproof Courtesy Lights.	22
Waterproof LED Courtesy Lights.	22

CLEARANCE / SIDE MARKER LIGHTS

Waterproof LED Clearance / Side Marker Lights.	23-26
LED Clearance / Side Marker Lights.	27-28
Waterproof Clearance / Side Marker Lights.	29-31
Clearance / Side Marker Lights.	32-35
LED Light Strips / Strobe Lights.	36

IDENTIFICATION LIGHT BARS

Waterproof LED ID Light Bars.	37
LED ID Light Bars.	37
Waterproof ID Light Bars.	38

LIGHTING ACCESSORIES

License Plate Lights / Brackets	39-40
Reflectors.	41
Porch / Utility / Security Lights.	42-43
Interior Lights.	43

LIGHTING STANDARDS / INFORMATION

Bulb Specification.	44
Lighting Tips.	45
Lighting FAQs.	45
Lighting Terminology.	46
Lighting Required Equipment	46

NEW PRODUCTS



WATERPROOF LED OVER 80" WRAP-AROUND TAIL LIGHTS

- Stainless steel mounting hardware included
- Designed for 2' or 4' wide x 4' high areas



WATERPROOF LED 4" ROUND TAIL LIGHT

- Flush mount with clear lens
- 24 LED's and perimeter reflex ring

FEATURED PRODUCTS



SURFACE MOUNT LED DOUBLE TAIL LIGHTS #84 SERIES / #85 SERIES

- Vertical or horizontal mounting applications
- Black or chrome plated finish

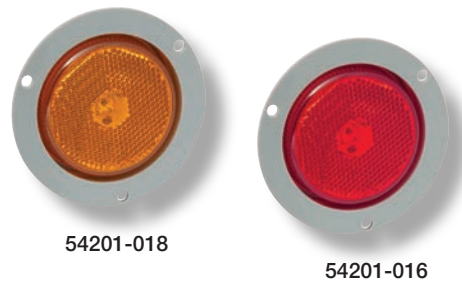

LED CLEARANCE/SIDE MARKER LIGHT 2 1/2" ROUND

- Surface mount design
- Two wire construction simplifies grounding



WATERPROOF LED ID LIGHT BAR

- Stainless steel base with stud mounting
- Designed for 2' or 4' wide x 4' high areas
- Waterproof



WATERPROOF LED LOW PROFILE TAIL LIGHT KIT

- Over 80", 3 x 8
- Includes 25' harness

LED MODULE KITS #84/85/86 SERIES TAIL LIGHTS

Quick and simple LED module kit for existing #84 series tail lights. Remove the bulb and lens, replace with new LED module and instantly have LED red stop/tail/turn lights, amber turn lights, clear backup lights or clear backup w/reflex lights. Installation can be completed in minutes with only a screwdriver required.



Part No.	Description	Packaging
42-84-410	LED Stop/Tail/Turn Light Lens Module Red w/Bulb Socket Plug	Bargman Clam
47-84-410	LED Stop/Tail/Turn Light Lens Module Red w/Bulb Socket Plug	Bargman Bagged
42-84-412	LED Turn Light Lens Module Amber w/Bulb Socket Plug	Bargman Clam
47-84-412	LED Turn Light Lens Module Amber w/Bulb Socket Plug	Bargman Bagged
47-84-026	LED Backup Light Lens Module Clear w/Bulb Socket Plug - Lens Mounted Vertical	Bargman/Wesbar Bulk

ENHANCED HEIGHT INCANDESCENT LENS #84/85/86 SERIES TAIL LIGHTS - BACKUP (OR RED W/RED INSERT) LENS ONLY

Part No.	Description	Packaging
47-84-711	Enhanced Height Incandescent Backup Lens Only - Red Reflex w/Clear Center - Red Border	Bargman/Wesbar Bulk
48-84-711	Enhanced Height Incandescent Backup Lens Only - Red Reflex w/Clear Center - Red Border	Bargman Bagged
47-85-711	Enhanced Height Incandescent Backup Lens Only - Red Reflex w/Clear Center - Chrome Border	Bargman/Wesbar Bulk
48-85-711	Enhanced Height Incandescent Backup Lens Only - Red Reflex w/Clear Center - Chrome Border	Bargman Bagged
47-84-712	Enhanced Height Incandescent Lens Only - Red Reflex w/Red Center - Red Border	Bargman/Wesbar Bulk
48-84-712	Enhanced Height Incandescent Lens Only - Red Reflex w/Red Center - Red Border	Bargman Bagged

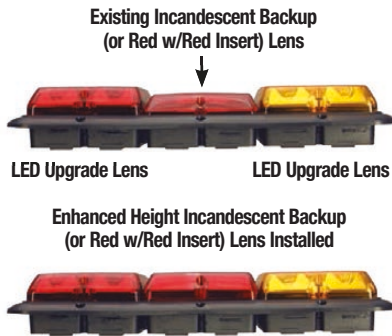

LED MODULE KIT #86 SERIES WRAP-AROUND CLEARANCE/SIDE MARKER LIGHTS

Quick and simple LED module kit for existing #86 series wrap-around clearance/side marker lights. Remove and discard only the wedge base socket and bulb, replace with a new LED module and instantly have LED clearance/side marker lights.



Part No.	Description	Packaging
42-86-410	LED Wrap-Around Clearance Light Module Red	Bargman Clam
47-86-410	LED Wrap-Around Clearance Light Module Red	Bargman Bagged
42-86-412	LED Wrap-Around Clearance Light Module Amber	Bargman Clam
47-86-412	LED Wrap-Around Clearance Light Module Amber	Bargman Bagged

BARGMAN #84/85/86 LED LIGHTS

LED Tail Lights and Module Kit for the most popular RV Tail Light in the World! Purchase as fully-assembled complete tail lights for installation or purchase a LED Upgrade Module. The Module Kit will allow you to quickly and easily field upgrade your installed Bargman Model #84/85/86 Tail Lights or Model #86 Wrap-Around Marker/Clearance lights from Incandescent to LED.

HOW TO ORDER

Fully assembled units:

Fully assembled LED versions of the Bargman #84/85/86 tail lights and #86 wrap-around clearance/side marker lights are listed. For convenience and consistency, we have listed them in the same manner that we list the incandescent models. Please note that the part numbers for all LED versions begin with 42/47/48-.

Module Kits:

These kits are designed to allow RV and Trailer owners to upgrade their Bargman #84/ 85/86 Tail Lights or #86 Wrap-Around Marker/Clearance lights from Incandescent to LED - quickly and safely. Due to the many configurations of these Bargman light models, upgrade modules are sold to upgrade only one module at a time.

WARNING: All Bargman #84/85/86 Tail Lights and #86 Wrap-Around Marker/Clearance lights meet FMVSS/CMVSS 108 requirements. **WHEN UPGRADING EXISTING LIGHTS FROM INCANDESCENT TO LED, TO RETAIN FMVSS/CMVSS 108 REQUIREMENTS, SPECIAL CARE MUST BE GIVEN TO REPLACE EXISTING LENS (OR TO ASSEMBLE MODULE) WITH A LED MODULE THAT WILL PERFORM THE EXACT SAME FUNCTION.**

NOTE: For regulatory purposes, installation of any competitive LED Upgrade Module designed for the Bargman #84/85/86 Tail Lights will immediately void all warranty on the entire Bargman tail light.

#84 Series Tail Lights LED Upgrade Modules

The end-user will simply count the number of red stop/tail/turn lights, amber turn lights or backup lights on the vehicle and order the appropriate number of the desired LED upgrade modules. The end user will simply remove the incandescent lens and bulb and plug the LED module (LED circuit board with connector and lens) into the existing bulb socket and mount, with the existing screws, to the holes in the existing light base.

#86 Series Marker Light LED Upgrade Module

The end-user will simply count the number of wrap-around clearance/side marker lights on the vehicle and order the appropriate number of the desired LED upgrade kits. The end user will simply remove the lens and bulb and plug the LED module (LED circuit board) into the existing bulb socket and re-install the existing lens.



LED SINGLE TAIL LIGHTS #86 SERIES

These LED lights meet FMVSS/CMVSS 108 requirements. Bases are available in either white or black. All include 16 gauge supply and ground wiring.

5 13/16" X 4 3/8" X 2 7/8"

Part No.	Description	Packaging
47-86-101	LED Stop/Tail/Turn w/Black Base	Bargman/Wesbar Bulk
42-86-101	LED Stop/Tail/Turn w/Black Base	Bargman Clam
48-86-101	LED Stop/Tail/Turn w/Black Base	Bargman Bagged

REPLACEMENT PARTS

Part No.	Description
47-84-420	LED Stop/Tail/Turn Light Lens Module Red w/Wires

LED NARROW TAIL LIGHT #54 SERIES

This LED tail light with 3 diodes is designed for a narrow rail surface mounting. Features include built-in reflex reflectors and mounting holes with stainless steel grommets. This light meets FMVSS/CMVSS 108 requirements. Prewired (supply and ground) for easy installation.

15.84" x 2.29" - Mounting holes on 14.49" centers



Part No.	Description	Packaging
47-54-001	Red Stop/Tail/Turn	Bargman/Wesbar Bulk

LED NARROW RED LED TAIL LAMP

Featuring LED Technology, ,meets FMVSS/ CMVSS 108 requirements.

14.1" x 1"



Part No.	Description	Packaging
54200-015	Narrow Red LED low and high function tail light	Wesbar Box
54200-016	Chrome Bezel for #54200-015	Wesbar Box

NOTE: Tail Lights, Clearance/Side Marker Lights and ID Light Bars approved for trailer accessory and towing application use. Contact your Horizon Global Representative for details.



LED SURFACE MOUNT DOUBLE TAIL LIGHTS #84 SERIES / #85 SERIES

These LED double lights are available for surface mounting in vertical or horizontal applications. Stylish bases with radius corners come in either black or chrome plated finish. All lenses meet FMVSS/CMVSS 108 requirements. Reflex is included on backup lens. Prewired (supply and ground) for easy installation.

10 1/4" x 7 1/4" x 1 7/8".

Part No.	Description	Packaging
47-84-610	LED Red Stop/Tail/Turn, LED Red Stop/Tail/Turn w/Black Base	Bargman/Wesbar Bulk
47-85-611	LED Red Stop/Tail/Turn, LED Red Stop/Tail/Turn w/Chrome Base	Bargman/Wesbar Bulk

REPLACEMENT PARTS

Part No.	Description
47-84-420	LED Stop/Tail/Turn Light Lens Module Red w/Wires



LED RECESSED DOUBLE TAIL LIGHTS #84 SERIES / #85 SERIES

LED double lights for either vertical or horizontal mounting. Radius corners. Black, white and colonial white bases. Clear LED or incandescent backup light lenses are surrounded by a Class "A" red reflex lens. Incandescent lens, red w/red insert, is for clearance/side marker application only. All lenses meet FMVSS/CMVSS 108 requirements. Prewired (supply and ground) for easy installation.

Cutout: 8 7/16" X 5 1/2", Overall: 9 13/16" X 6 15/16" X 1 1/4" w/ 1" depth

Part No.	Description	Packaging
47-84-527	LED Red Stop/Tail/Turn, LED Red Stop/Tail/Turn w/Black Base	Bargman/Wesbar Bulk
48-84-527	LED Red Stop/Tail/Turn, LED Red Stop/Tail/Turn w/Black Base	Bargman Bagged
47-84-001	LED Red Stop/Tail/Turn, Incandescent Backup w/Colonial White Base	Bargman/Wesbar Bulk
47-84-540	LED Red Stop/Tail/Turn, Incandescent Backup w/White Base	Bargman/Wesbar Bulk
47-84-008	LED Red Stop/Tail/Turn, Incandescent Backup w/Black Base	Bargman/Wesbar Bulk
48-84-008	LED Red Stop/Tail/Turn, Incandescent Backup w/Black Base	Bargman Bagged
47-84-529	LED Red Stop/Tail/Turn, Incandescent Red w/Red Insert (Clearance/Side Marker Application Only) w/Black Base	Bargman/Wesbar Bulk
48-84-529	LED Red Stop/Tail/Turn, Incandescent Red w/Red Insert (Clearance/Side Marker Application Only) w/Black Base	Bargman Bagged
47-84-808	LED Red Stop/Tail/Turn, Incandescent Backup w/Black Base, 12" 4/Conductor Cord w/4-Way Square Connector	Bargman/Wesbar Bulk

REPLACEMENT PARTS

Part No.	Description	Packaging
47-84-420	LED Stop/Tail/Turn Light Lens Module Red w/Wires	Bargman Bagged
47-84-711	Enhanced Height Incandescent Backup Lens Only - Red Reflex w/ Clear Center - Red Border	Bargman/Wesbar Bulk
48-84-711	Enhanced Height Incandescent Backup Lens Only - Red Reflex w/ Clear Center - Red Border	Bargman Bagged
47-84-712	Enhanced Height Incandescent Lens Only - Red Reflex w/Red Center - Red Border	Bargman/Wesbar Bulk
48-84-712	Enhanced Height Incandescent Lens Only - Red Reflex w/Red Center - Red Border	Bargman Bagged

NOTE: Tail Lights, Clearance/Side Marker Lights and ID Light Bars approved for trailer accessory and towing application use. Contact your Horizon Global Representative for details.



LED RECESSED TRIPLE TAIL LIGHTS #84 SERIES/#85 SERIES

LED triple lights for either vertical or horizontal mounting. Radius corners. Bases in black, white, colonial white and chrome plated finish. Clear LED or incandescent backup light lenses surrounded by a Class "A" red reflex lens. Incandescent lens, red w/red insert, for clearance/side marker application only. Lenses meet FMVSS/CMVSS 108 requirements. Prewired (supply and ground) for easy installation.

Cutout: 12 11/16" X 5 1/2", Overall: 14 1/16" X 6 15/16" X 1 1/4" w/ 1" depth

Part No.	Description	Packaging
47-84-530	LED Red, LED Red Stop/Tail/Turn, Incandescent Backup w/White Base	Bargman/Wesbar Bulk
47-84-009	LED Red, LED Red Stop/Tail/Turn, Incandescent Backup w/Black Base	Bargman/Wesbar Bulk
48-84-009	LED Red, LED Red Stop/Tail/Turn, Incandescent Backup w/Black Base	Bargman Bagged
47-85-002	LED Red, LED Red Stop/Tail/Turn, Incandescent Backup w/Chrome Base	Bargman/Wesbar Bulk
47-84-005	LED Red Stop/Tail/Turn, LED Amber Turn, Incandescent Backup w/Black Base	Bargman/Wesbar Bulk
47-85-004	LED Red Stop/Tail/Turn, LED Amber Turn, Incandescent Backup w/Chrome Base	Bargman/Wesbar Bulk

REPLACEMENT PARTS

Part No.	Description	Packaging
47-84-420	LED Stop/Tail/Turn Light Lens Module Red w/Wires	Bargman Bagged
47-84-711	Enhanced Height Incandescent Backup Lens Only - Red Reflex w/ Clear Center - Red Border	Bargman/Wesbar Bulk
48-84-711	Enhanced Height Incandescent Backup Lens Only - Red Reflex w/ Clear Center - Red Border	Bargman Bagged
47-84-712	Enhanced Height Incandescent Lens Only - Red Reflex w/Red Center - Red Border	Bargman/Wesbar Bulk
48-84-712	Enhanced Height Incandescent Lens Only - Red Reflex w/Red Center - Red Border	Bargman Bagged



LED RECESSED TRIPLE LONG TAIL LIGHTS #84 SERIES / #85 SERIES

This series of LED triple tail lights incorporates all of the features of the LED Recessed Triple Tail Light #84 Series/ #85 Series with a special lens placement that allows the light to be utilized for a narrow mounting.

Cutout: 16 1/8" X 3 5/8", Overall: 18" X 5 5/16" X 1 1/4" w/ 1" depth

Part No.	Description	Packaging
47-84-103	LED Red Stop/Tail/Turn, Incandescent Backup, LED Red Stop/Tail/Turn w/Black Base	Bargman/Wesbar Bulk
47-84-104	LED Red Stop/Tail/Turn, Incandescent Backup, LED Amber Turn w/Black Base	Bargman/Wesbar Bulk

REPLACEMENT PARTS

Part No.	Description	Packaging
47-84-420	LED Stop/Tail/Turn Light Lens Module Red w/Wires	Bargman Bagged
47-84-711	Enhanced Height Incandescent Backup Lens Only - Red Reflex w/ Clear Center - Red Border	Bargman/Wesbar Bulk
48-84-711	Enhanced Height Incandescent Backup Lens Only - Red Reflex w/ Clear Center - Red Border	Bargman Bagged
47-84-712	Enhanced Height Incandescent Lens Only - Red Reflex w/Red Center - Red Border	Bargman/Wesbar Bulk
48-84-712	Enhanced Height Incandescent Lens Only - Red Reflex w/Red Center - Red Border	Bargman Bagged

NOTE: Tail Lights, Clearance/Side Marker Lights and ID Light Bars approved for trailer accessory and towing application use. Contact your Horizon Global Representative for details.

WATERPROOF LED OVER 80" 3X8 LOW PROFILE TAIL LIGHTS 

These waterproof lights meet FMVSS/CMVSS 108 requirements for trailers over 80" wide when properly mounted. Includes stainless steel mounting hardware. Includes 3-wire plug-in harness with 12" wire leads and 7" ring terminal ground. 8" x 3.5" x 3"



Part No.	Description	Packaging
271574	7-Function, Right/Curbside	Bargman/Wesbar Bulk
407530	7-Function, Right/Curbside	Wesbar Packaging
271575	8-Function, Left/Roadside	Bargman/Wesbar Bulk
407535	8-Function, Left/Roadside	Wesbar Packaging

Kit comes complete with two low profile tail lights, 25' trailer wiring harness cable with molded 4-way plug, 4' four wire car wiring harness cable with molded 4-way plug and license plate bracket.

Part No.	Description	Packaging
31-407540	Trailer Light Kit	Bargman Clam
407540	Trailer Light Kit	Wesbar Packaging

REPLACEMENT PARTS

Part No.	Description	Packaging
40-00-004	3 Wire 90° Pigtail w/12" Wire Lead	Bargman/Wesbar Bulk
719063	3 Wire 90° Pigtail w/12" Wire Lead	Wesbar Packaging
003201	License Plate Bracket	Bargman/Wesbar Bulk
003211	License Plate Bracket	Wesbar Packaging
54504-001	Protective Tail Light Bracket	Wesbar Packaging
54504-003	Protective Tail Light Bracket - Pair	Wesbar Packaging
002301	4' Wiring Harness w/4-Way Flat Car End	Bargman/Wesbar Bulk
707275	4' Wiring Harness w/4-Way Flat Car End	Wesbar Packaging
108825	25' Wiring Harness w/4-Way Flat Trailer End	Bargman/Wesbar Bulk
707261	25' Wiring Harness w/4-Way Flat Trailer End	Wesbar Packaging

WATERPROOF LED OVER 80" WRAP-AROUND TAIL LIGHTS 

Waterproof surface mount tail lights. Wrap-around design eliminates the need for rear side marker/reflector. These lights meet FMVSS/CMVSS 108 requirements. Plug-in 12" harness with 2-way flat connector and ring terminal ground wire. Stainless steel mounting hardware included.

7.53" x 3.48" x 3.13"



Part No.	Description	Packaging
271594	7-Function, Right/Curbside	Bargman/Wesbar Bulk
281594	7-Function, Right/Curbside	Wesbar Packaging
271595	8-Function, Left/Roadside	Bargman/Wesbar Bulk
281595	8-Function, Left/Roadside	Wesbar Packaging

REPLACEMENT PARTS

Part No.	Description	Packaging
54504-001	Protective Tail Light Bracket	Wesbar Packaging
54504-003	Protective Tail Light Bracket - Pair	Wesbar Packaging

NOTE: Tail Lights, Clearance/Side Marker Lights and ID Light Bars approved for trailer accessory and towing application use. Contact your Horizon Global Representative for details.





WATERPROOF LED OVER 80" 4X6 LOW PROFILE TAIL LIGHTS



Unique, compact size and shape allows these waterproof lights to fit where space is limited. Meets FMVSS/CMVSS 108 requirements for trailers over 80" wide when properly mounted. Includes stainless steel mounting hardware.

6" x 3 1/2" x 2 1/4"

Part No.	Description	Packaging
271584	7-Function, Right/Curbside	Bargman/Wesbar Bulk
271584-01	7-Function, Right/Curbside w/3 Wire Pigtail	Bargman/Wesbar Bulk
407550	7-Function, Right/Curbside w/3 Wire 90° Pigtail	Wesbar Packaging
271585	8-Function, Left/Roadside	Bargman/Wesbar Bulk
34-271585	8-Function, Left/Roadside	Bargman/Wesbar Bulk
271585-01	8-Function, Left/Roadside w/3 Wire Pigtail	Bargman/Wesbar Bulk
407555	8-Function, Left/Roadside w/3 Wire 90° Pigtail	Wesbar Packaging

Kit comes complete with two low profile tail lights, 25' trailer wiring harness cable with molded 4-way plug, 4' car wiring harness cable with molded 4-way plug and license plate bracket.

Part No.	Description	Packaging
31-407560	Trailer Light Kit	Bargman Clam
407560	Trailer Light Kit	Wesbar Packaging

REPLACEMENT PARTS

Part No.	Description	Packaging
40-00-003	3 Wire Pigtail w/12" Wire Lead	Bargman/Wesbar Bulk
44-00-003	3 Wire Pigtail w/12" Wire Lead	Bargman Bagged
40-00-004	3 Wire 90° Pigtail w/12" Wire Lead	Bargman/Wesbar Bulk
719063	3 Wire 90° Pigtail w/12" Wire Lead	Wesbar Packaging
003201	License Plate Bracket	Bargman/Wesbar Bulk
003211	License Plate Bracket	Wesbar Packaging
54504-001	Protective Tail Light Bracket	Wesbar Packaging
54504-003	Protective Tail Light Bracket - Pair	Wesbar Packaging
002301	4' Wiring Harness w/4-Way Flat Car End	Bargman/Wesbar Bulk
707275	4' Wiring Harness w/4-Way Flat Car End	Wesbar Packaging
108825	25' Wiring Harness w/4-Way Flat Trailer End	Bargman/Wesbar Bulk
707261	25' Wiring Harness w/4-Way Flat Trailer End	Wesbar Packaging

WATERPROOF LED 4" ROUND TAIL LIGHT



Featuring LED Technology, this grommet light is waterproof and meets FMVSS/CMVSS 108 requirements.

Part No.	Description	Packaging
47-01-031	Red Stop/Tail/Turn Light w/Grommet w/Pigtail	Bargman Bagged
54200-012	Clear Lens LED Tail Lamp with Mounting Flange	Bargman Bulk
54200-013	Clear Lens LED Tail Lamp with Mounting Flange	Bargman Clam
54200-018	Amber Lens LED Turn Lamp	Wesbar Bulk

REPLACEMENT PARTS

Part No.	Description	Packaging
47-01-001	Stop/Tail/Turn Light 4" Round Red	Bargman/Wesbar Bulk
40-00-006	Pigtail	Bargman/Wesbar Bulk
40-01-020	4" Round Grommet	Wesbar Packaging
44-01-020	4" Round Grommet	Bargman Bagged

NOTE: Tail Lights, Clearance/Side Marker Lights and ID Light Bars approved for trailer accessory and towing application use. Contact your Horizon Global Representative for details.





WATERPROOF LED 6" OVAL GROMMET MOUNT TAIL LIGHTS 

Featuring LED Technology, these grommet mount lights are waterproof and meet FMVSS/CMVSS 108 requirements. Lights are mounting-orientation specific. Mounting bracket of 11 ga. steel available separately. 6 1/2" x 2 5/16" x 7/8"

Part No.	Description	Packaging
47-06-034	Red Stop/Tail/Turn Light Horizontal Mount w/Grommet w/90° Pigtail	Bargman Bagged

REPLACEMENT PARTS

Part No.	Description	Packaging
47-06-004	Red Stop/Tail/Turn Light Horizontal Mount	Bargman/Wesbar Bulk
47-06-404	Red Stop/Tail/Turn Light Horizontal Mount	Bargman Bagged
401584	Red Stop/Tail/Turn Light Horizontal Mount	Wesbar Packaging
40-00-003	3 Wire Pigtail w/12" Wire Lead	Bargman/Wesbar Bulk
44-00-003	3 Wire Pigtail w/12" Wire Lead	Bargman Bagged
40-00-004	3 Wire 90° Pigtail w/12" Wire Lead	Bargman/Wesbar Bulk
719063	3 Wire 90° Pigtail w/12" Wire Lead	Wesbar Packaging
40-06-020	6" Oval Grommet	Bargman/Wesbar Bulk
44-06-020	6" Oval Grommet	Bargman Bagged
416088	6" Oval Grommet	Wesbar Packaging
108119	6" Oval Mounting Bracket	Bargman/Wesbar Bulk
34-108119	6" Oval Mounting Bracket	Bargman Bagged
106873	6" Oval Mounting Bracket	Wesbar Packaging
401591	6" Oval Grommet & 3 Wire 90° Pigtail	Wesbar Packaging



WATERPROOF LED 6" OVAL GROMMET MOUNT TAIL LIGHTS 

Featuring LED Technology, these grommet mount lights with 10 diodes are waterproof and meet FMVSS/CMVSS 108 requirements. Approved for vertical or horizontal mounting. Grommet, 3 prong wiring pigtail and 11 ga. steel mounting bracket available separately. 6.42" x 2.28" x 1"

Part No.	Description	Packaging
54006	Red Stop/Tail/Turn Light w/Grommet w/3 Wire 90° Pigtail	Wesbar Packaging
273561	Red Stop/Tail/Turn Light	Bargman/Wesbar Bulk
283561	Red Stop/Tail/Turn Light	Wesbar Packaging
273564	Amber Turn Light	Bargman/Wesbar Bulk
283564	Amber Turn Light	Wesbar Packaging
273565	White Backup Light	Bargman/Wesbar Bulk
283565	White Backup Light	Wesbar Packaging

ACCESSORY PARTS

Part No.	Description	Packaging
40-00-003	3 Wire Pigtail w/12" Wire Lead	Bargman/Wesbar Bulk
44-00-003	3 Wire Pigtail w/12" Wire Lead	Bargman Bagged
40-00-004	3 Wire 90° Pigtail w/12" Wire Lead	Bargman/Wesbar Bulk
719063	3 Wire 90° Pigtail w/12" Wire Lead	Wesbar Packaging
44-06-020	6" Oval Grommet	Bargman/Wesbar Bulk
44-06-020	6" Oval Grommet	Bargman Bagged
416088	6" Oval Grommet	Wesbar Packaging
108119	6" Oval Mounting Bracket	Bargman/Wesbar Bulk
34-108119	6" Oval Mounting Bracket	Bargman Bagged
106873	6" Oval Mounting Bracket	Wesbar Packaging
401591	6" Oval Grommet & 3 Wire 90° Pigtail	Wesbar Packaging

NOTE: Tail Lights, Clearance/Side Marker Lights and ID Light Bars approved for trailer accessory and towing application use. Contact your Horizon Global Representative for details.





WATERPROOF LED 6" OVAL SURFACE FLANGE MOUNT TAIL LIGHTS 

Featuring LED Technology, these flange mount lights are waterproof and meet FMVSS/CMVSS 108 requirements. Surface mounting with prewired supply and ring terminal ground for easy installation.

7.5" x 3.28" x .82"

Part No.	Description	Packaging
54004	Red Stop/Tail/Turn w/Black Flange w/Chrome Trim Snap Ring	Wesbar Packaging
50-767751	Red Stop/Tail/Turn w/Black Flange	Bargman/Wesbar Bulk
50-767752	Red Stop/Tail/Turn w/Black Flange	Bargman/Wesbar Bulk
40-767758	Amber Turn w/Black Flange	Bargman/Wesbar Bulk

ACCESSORY PARTS

Part No.	Description	Packaging
85-767010	Chrome Trim Snap Ring	Bargman/Wesbar Bulk



SUBMERSIBLE LED UNDER 80" COMBINATION TAIL LIGHTS 

These lights are ideal for boat and PWC trailers less than 80" wide and meet FMVSS/CMVSS 108 requirements. Stud mounted using 2" O.C. industry standard stud configuration. Prewired (supply and ground) for easy installation.

5.12" x 4.50" x 1.85" w/.86" depth

Part No.	Description	Packaging
273006	7-Function, Left/Roadside	Bargman/Wesbar Bulk
283006	7-Function, Left/Roadside	Wesbar Packaging
273056	6-Function, Right/Curbside	Bargman/Wesbar Bulk
283056	6-Function, Right/Curbside	Wesbar Packaging

Complete kit with two tail lights, 25' trailer wiring harness cable with molded 4-way flat prong plug, 4' car harness cable with molded 4-way flat prong plug and license plate bracket.

Part No.	Description	Packaging
287512	Trailer Light Kit w/25' Wire Harness	Wesbar Packaging

REPLACEMENT PARTS

Part No.	Description	Packaging
54504-001	Protective Tail Light Bracket	Wesbar Packaging
54504-003	Protective Tail Light Bracket - Pair	Wesbar Packaging



SUBMERSIBLE LED OVER 80" COMBINATION TAIL LIGHTS 

These lights are ideal for boat and PWC trailers and meet FMVSS/CMVSS 108 requirements for trailers over 80" wide when properly mounted. Stud mounted using 2" O.C. industry standard stud configuration. Prewired (supply and ground) for easy installation.

5.48" x 4.50" x 1.85" w/.86" depth

Part No.	Description	Packaging
273008	8 Function Left/Roadside	Bargman/Wesbar Bulk
273058	7 Function Right/Curbside	Bargman/Wesbar Bulk

REPLACEMENT PARTS

Part No.	Description	Packaging
54504-001	Protective Tail Light Bracket	Wesbar Packaging
54504-003	Protective Tail Light Bracket - Pair	Wesbar Packaging

NOTE: Tail Lights, Clearance/Side Marker Lights and ID Light Bars approved for trailer accessory and towing application use. Contact your Horizon Global Representative for details.





SINGLE TAIL LIGHTS #86 SERIES

These lights meet FMVSS/CMVSS 108 requirements. Backup light has a clear lens surrounded by a Class "A" reflector. Bases are available in either white or black. All include J-slot bayonet sockets for dependable flicker-free operation and 16 gauge supply and ground wiring.

5 13/16" X 4 3/8" X 2 7/8", Cutout: 5 7/8" X 5 1/2"

Part No.	Description	Packaging
30-86-101	Red Stop/Tail/Turn w/Black Base	Bargman/Wesbar Bulk
31-86-101	Red Stop/Tail/Turn w/Black Base	Bargman Clam
34-86-101	Red Stop/Tail/Turn w/Black Base	Bargman Bagged
30-86-103	Backup Vertical Mount w/Black Base	Bargman/Wesbar Bulk
31-86-103	Backup Vertical Mount w/Black Base	Bargman Clam
34-86-103	Backup Vertical Mount w/Black Base	Bargman Bagged
30-86-107	Amber Turn w/Black Base	Bargman Bulk

REPLACEMENT PARTS

Part No.	Description	Packaging
30-90-156	Bulb #1156, Single Filament	Bargman/Wesbar Bulk
30-84-057	Bulb #2057, Double Filament	Bargman/Wesbar Bulk
31-84-010	Lens Red	Bargman Clam
34-84-010	Lens Red	Bargman Bagged
31-84-016	Lens Amber	Bargman Clam
34-84-016	Lens Amber	Bargman Bagged
31-84-700	Lens Backup - Lens Mounted Vertical	Bargman Clam
34-84-700	Lens Backup - Lens Mounted Vertical	Bargman Bagged
31-84-711	Lens Backup - Lens Mounted Horizontal	Bargman Clam
34-84-711	Lens Backup - Lens Mounted Horizontal	Bargman Bagged
30-84-075	Tail Light Lens Screw	Bargman/Wesbar Bulk



WRAP-AROUND CLEARANCE/SIDE MARKER LIGHTS #86 SERIES

This 90 degree wrap-around light meets lighting requirements for side markers and clearance lights and doubles as a Class "A" side-reflex reflector. The light meets FMVSS/CMVSS 108 requirements. Bases are available in either white or black. The molded socket with two wires protects bulb from road shock and the molded grommet protects the wiring.

5 3/4" X 4 3/8" X 2 3/16"

Part No.	Description	Packaging
30-86-005	Red w/Colonial White Base	Bargman/Wesbar Bulk
30-86-202	Red w/Black Base	Bargman/Wesbar Bulk
34-86-202	Red w/Black Base	Bargman Bagged
30-86-203	Amber w/Black Base	Bargman/Wesbar Bulk
34-86-203	Amber w/Black Base	Bargman Bagged

REPLACEMENT PARTS

Part No.	Description	Packaging
30-86-711	Lens #86 Red Wrap Around	Bargman/Wesbar Bulk
34-86-711	Lens #86 Red Wrap Around	Bargman Bagged
30-86-712	Lens #86 Amber Wrap Around	Bargman/Wesbar Bulk
34-86-712	Lens #86 Amber Wrap Around	Bargman Bagged
30-84-075	Marker Light Lens Screw	Bargman/Wesbar Bulk

NOTE: Tail Lights, Clearance/Side Marker Lights and ID Light Bars approved for trailer accessory and towing application use. Contact your Horizon Global Representative for details.



RECESSED DOUBLE TAIL LIGHTS #84 SERIES

These double lights are available for vertical or horizontal mounting. These stylish units with their radius corners come in black, white and colonial white. Clear backup light lenses are surrounded by a Class "A" red reflex lens. All lenses meet FMVSS/CMVSS 108 requirements. All include J-slot bayonet sockets for dependable flicker-free operation and 16 gauge supply and ground wiring.

Cutout: 8 7/16" X 5 1/2", Overall: 9 13/16" X 6 15/16" X 1 1/4" w/ 1" depth

Part No.	Description	Packaging
30-84-001	Horizontal Mount w/Red Stop/Tail/Turn, Backup Lens w/Colonial White Base	Bargman/Wesbar Bulk
30-84-540	Horizontal Mount w/Red Stop/Tail/Turn, Backup Lens w/White Base	Bargman/Wesbar Bulk
30-84-008	Horizontal Mount w/Red Stop/Tail/Turn, Backup Lens w/Black Base	Bargman/Wesbar Bulk
34-84-008	Horizontal Mount w/Red Stop/Tail/Turn, Backup Lens w/Black Base	Bargman Bagged
30-84-508	Vertical Mount w/Red Stop/Tail/Turn, Backup Lens w/Black Base	Bargman/Wesbar Bulk
30-84-547	Red/Red Stop/Tail/Turn w/White Base	Bargman/Wesbar Bulk
30-84-527	Red/Red Stop/Tail/Turn w/Black Base	Bargman/Wesbar Bulk
34-84-527	Red/Red Stop/Tail/Turn w/Black Base	Bargman Bagged
30-84-529	Red Stop/Tail/Turn, w/Red Insert (Clearance/Side Marker Application Only) w/Black Base	Bargman/Wesbar Bulk
34-84-529	Red Stop/Tail/Turn, w/Red Insert (Clearance/Side Marker Application Only) w/Black Base	Bargman Bagged

REPLACEMENT PARTS

Part No.	Description	Packaging
30-90-156	Bulb #1156, Single Filament	Bargman/Wesbar Bulk
30-84-057	Bulb #2057, Double Filament	Bargman/Wesbar Bulk
31-84-010	Lens Red	Bargman Clam
34-84-010	Lens Red	Bargman Bagged
31-84-016	Lens Amber	Bargman Clam
34-84-016	Lens Amber	Bargman Bagged
31-84-700	Lens Backup - Lens Mounted Vertical	Bargman Clam
34-84-700	Lens Backup - Lens Mounted Vertical	Bargman Bagged
31-84-711	Lens Backup - Lens Mounted Horizontal	Bargman Clam
34-84-711	Lens Backup - Lens Mounted Horizontal	Bargman Bagged
34-85-750	Lens Red w/Red Insert (Clearance/Side Marker Application Only)	Bargman Bagged
30-84-075	Tail Light Lens Screw	Bargman/Wesbar Bulk

NOTE: Tail Lights, Clearance/Side Marker Lights and ID Light Bars approved for trailer accessory and towing application use. Contact your Horizon Global Representative for details.

RECESSED TRIPLE LONG TAIL LIGHTS #84 SERIES

These triple tail lights incorporate all the features of the Recessed Triple Tail Light #84 Series with lens placement that allows a narrow mounting.

Cutout: 16 1/8" X 3 5/8", Overall: 18" X 5 5/16" X 1 1/4" w/ 1" depth"



Part No.	Description	Packaging
30-84-103	Horizontal Mount w/Red Stop/Tail/Turn, Center Backup, Red Stop/Tail/Turn w/Black Base	Bargman/Wesbar Bulk
30-84-104	Horizontal Mount w/Red Stop/Tail/Turn, Center Backup, Amber Turn w/Black Base	Bargman/Wesbar Bulk
30-84-554	Vertical Mount w/Red Stop/Tail/Turn, Center Backup, Amber Turn w/Black Base	Bargman/Wesbar Bulk

REPLACEMENT PARTS

Part No.	Description	Packaging
30-90-156	Bulb #1156, Single Filament	Bargman/Wesbar Bulk
30-84-057	Bulb #2057, Double Filament	Bargman/Wesbar Bulk
31-84-010	Lens Red	Bargman Clam
34-84-010	Lens Red	Bargman Bagged
31-84-016	Lens Amber	Bargman Clam
34-84-016	Lens Amber	Bargman Bagged
31-84-700	Lens Backup - Lens Mounted Vertical	Bargman Clam
34-84-700	Lens Backup - Lens Mounted Vertical	Bargman Bagged
31-84-711	Lens Backup - Lens Mounted Horizontal	Bargman Clam
34-84-711	Lens Backup - Lens Mounted Horizontal	Bargman Bagged
34-85-750	Lens Red w/Red Insert (Clearance/Side Marker Application Only)	Bargman Bagged
30-84-075	Tail Light Lens Screw	Bargman/Wesbar Bulk

RECESSED TRIPLE TAIL LIGHTS #84 SERIES/#85 SERIES

These triple lights are available for either vertical or horizontal mounting. These stylish units with their radius corners have bases available in either black, white, colonial white or chrome plated finish. Clear backup light lenses are surrounded by a Class "A" red reflex lens. All lenses meet FMVSS/CMVSS 108 requirements. All include J-slot bayonet sockets for dependable flicker-free operation and 16 gauge supply and ground wiring.

Cutout: 12 11/16" X 5 1/2", Overall: 14 1/16" X 6 15/16" X 1 1/4" w/ 1" depth



Part No.	Description	Packaging
30-84-002	Horizontal Mount w/Red, Red Stop/Tail/Turn, Backup w/Colonial White Base	Bargman/Wesbar Bulk
30-84-009	Horizontal Mount w/Red, Red Stop/Tail/Turn, Backup w/Black Base	Bargman/Wesbar Bulk
34-84-009	Horizontal Mount w/Red, Red Stop/Tail/Turn, Backup w/Black Base	Bargman Bagged
30-85-002	Horizontal Mount w/Red, Red Stop/Tail/Turn, Backup w/Chrome Base	Bargman/Wesbar Bulk
30-84-523	Vertical Mount w/Red/Red Stop/Tail/Turn, Backup w/White Base	Bargman/Wesbar Bulk
30-84-509	Vertical Mount w/Red/Red Stop/Tail/Turn, Backup w/Black Base	Bargman/Wesbar Bulk

REPLACEMENT PARTS

Part No.	Description	Packaging
30-90-156	Bulb #1156, Single Filament	Bargman/Wesbar Bulk
30-84-057	Bulb #2057, Double Filament	Bargman/Wesbar Bulk
31-84-010	Lens Red	Bargman Clam
34-84-010	Lens Red	Bargman Bagged
31-84-016	Lens Amber	Bargman Clam
34-84-016	Lens Amber	Bargman Bagged
31-84-700	Lens Backup - Lens Mounted Vertical	Bargman Clam
34-84-700	Lens Backup - Lens Mounted Vertical	Bargman Bagged
31-84-711	Lens Backup - Lens Mounted Horizontal	Bargman Clam
34-84-711	Lens Backup - Lens Mounted Horizontal	Bargman Bagged
34-85-750	Lens Red w/Red Insert (Clearance/Side Marker Application Only)	Bargman Bagged
30-84-075	Tail Light Lens Screw	Bargman/Wesbar Bulk

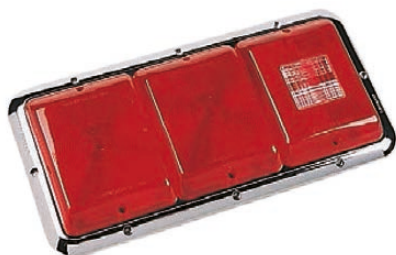

NOTE: Tail Lights, Clearance/Side Marker Lights and ID Light Bars approved for trailer accessory and towing application use. Contact your Horizon Global Representative for details.

SURFACE MOUNT TAIL LIGHTS #92 SERIES

Radius styling is the key to the smooth flowing design used in the #92 series tail light. Available with or without backup lenses, in red, these tail lights offer maximum design and replacement flexibility. Clean white or rich black bases. All include automotive corrosion resistant bulb sockets and 16 gauge supply and ground wiring. These lights meet FMVSS/CMVSS 108 requirements and are designed for long life and easy installation. These units are designed for horizontal, surface mounting only.

8 9/16" X 4 9/16" X 2 1/8"



54200-003-100



NOTE: Tail Lights, Clearance/Side Marker Lights and ID Light Bars approved for trailer accessory and towing application use. Contact your Horizon Global Representative for details.

Part No.	Description	Packaging
30-92-001	Stop/Tail/Turn Light Surface Mount #92 w/White Base	Bargman/Wesbar Bulk
31-92-001	Stop/Tail/Turn Light Surface Mount #92 w/White Base	Bargman Clam
34-92-001	Stop/Tail/Turn Light Surface Mount #92 w/White Base	Bargman Bagged
30-92-106	Stop/Tail/Turn Light Surface Mount #92 w/Black Base	Bargman/Wesbar Bulk
30-92-003	Stop/Tail/Turn Light Surface Mount #92 w/License Light & Bracket w/White Base	Bargman/Wesbar Bulk
31-92-003	Stop/Tail/Turn Light Surface Mount #92 w/License Light & Bracket w/White Base	Bargman Clam
34-92-003	Stop/Tail/Turn Light Surface Mount #92 w/License Light & Bracket w/White Base	Bargman Bagged
30-92-108	Stop/Tail/Turn Light Surface Mount #92 w/License Light & Bracket w/Black Base	Bargman/Wesbar Bulk
30-92-002	Stop/Tail/Turn Light Surface Mount #92 w/Backup w/White Base	Bargman/Wesbar Bulk
34-92-002	Stop/Tail/Turn Light Surface Mount #92 w/Backup w/White Base	Bargman Bagged
30-92-107	Stop/Tail/Turn Light Surface Mount #92 w/Backup w/Black Base	
30-92-004	Stop/Tail/Turn Light Surface Mount #92 w/Backup w/License Light & Bracket w/White Base	Bargman/Wesbar Bulk
34-92-004	Stop/Tail/Turn Light Surface Mount #92 w/Backup w/License Light & Bracket w/White Base	Bargman Bagged
30-92-109	Stop/Tail/Turn Light Surface Mount #92 w/Backup w/License Light & Bracket w/Black Base	Bargman/Wesbar Bulk

REPLACEMENT PARTS

Part No.	Description	Packaging
30-90-156	Bulb #1156, Single Filament	Bargman/Wesbar Bulk
30-90-157	Bulb #1157, Double Filament	Bargman/Wesbar Bulk
30-92-012	Lens for 30-92-001, 106	Bargman/Wesbar Bulk
34-92-012	Lens for 30-92-001, 106	Bargman Bagged
30-92-704	Lens for 30-92-002, 107	Bargman/Wesbar Bulk
34-92-704	Lens for 30-92-002, 107	Bargman Bagged
30-92-708	Lens for 30-92-003, 108	Bargman/Wesbar Bulk
34-92-708	Lens for 30-92-003, 108	Bargman Bagged
30-92-713	Lens for 30-92-004, 109	Bargman/Wesbar Bulk
34-92-713	Lens for 30-92-004, 109	Bargman Bagged
54200-003-100	Gasket (Foam) for #92 Series Tail Light (100 pack)	Bargman/Wesbar Bulk

WEDGE BASE FOR #92 SERIES TAIL LIGHTS

With the correct wedge, legal photometric function can be attained for the #92 Series tail lights which are mounted on surface angles as much as 15 degrees off the perpendicular.

Part No.	Description	Packaging
30-92-044	Tail Light 15 Degree Wedge Base for #92 Series, White #7, 9" x 5 1/8" x 1 1/2"	Bargman/Wesbar Bulk

COMBINATION UNDER 80" TAIL LIGHTS #80 SERIES

Universal 2" on center stud mounting. Screw-on main and side marker lens allow for easy bulb replacement. This tail light is designed for a variety of under 80" light-duty trailers. Wiring uses the quick connect and disconnect feature. These tail lights meet FMVSS/CMVSS 108 requirements.

4 3/4" x 4 1/2" x 2 9/16"



Part No.	Description	Packaging
2423283	7-Function, Left/Roadside	Bargman/Wesbar Bulk
2823283	7-Function, Left/Roadside	Wesbar Packaging
2423284	6-Function, Right/Curbside	Bargman/Wesbar Bulk
2823284	6-Function, Right/Curbside	Wesbar Packaging



Complete kit with two tail lights, two amber clearance/side marker lights with reflex lens, 20' or 25' trailer wiring harness cable with molded 4-way flat prong plug, 4' car wiring harness cable with molded 4-way flat prong plug plus license plate bracket.

Part No.	Description	Packaging
31-2823285	Trailer Light Kit w/25' Wire Harness, w/ Rectangular Clearance/Side Marker Lights	Bargman Clam
2823285	Trailer Light Kit w/25' Wire Harness, w/ Rectangular Clearance/Side Marker Lights	Wesbar Packaging
407500	Trailer Light Kit w/20' Wire Harness, w/o Clearance/Side Marker Lights	Wesbar Packaging

REPLACEMENT PARTS

Part No.	Description	Packaging
108891	Bulb #193	Bargman/Wesbar Bulk
30-90-157	Bulb #1157, Double Filament	Bargman/Wesbar Bulk
2423286	Lens, Tail Light	Bargman/Wesbar Bulk
2423287	Lens, Red, Clearance/Side Marker	Bargman/Wesbar Bulk
003201	License Plate Bracket	Bargman/Wesbar Bulk
003211	License Plate Bracket	Wesbar Packaging
54504-001	Protective Tail Light Bracket	Wesbar Packaging
54504-003	Protective Tail Light Bracket - Pair	Wesbar Packaging
002301	4' Wiring Harness w/4-Way Flat Car End	Bargman/Wesbar Bulk
707275	4' Wiring Harness w/4-Way Flat Car End	Wesbar Packaging
002220	20' Wiring Harness w/4-Way Flat Trailer End	Bargman/Wesbar Bulk

COMBINATION OVER 80" TAIL LIGHTS #80 SERIES

Universal 2" on center stud mounting. Screw-on main and side marker lens allow for easy bulb replacement. These tail lights meet FMVSS/CMVSS 108 requirements for trailers over 80" wide when properly mounted. Wiring uses the quick connect and disconnect feature.

6.09" x 4.59" x 2.87"



Part No.	Description	Packaging
2423293	8-Function, Left/Roadside	Bargman/Wesbar Bulk
2823293	8-Function, Left/Roadside	Wesbar Packaging
2423294	7-Function, Right/Curbside	Bargman/Wesbar Bulk
2823294	7-Function, Right/Curbside	Wesbar Packaging

REPLACEMENT PARTS

Part No.	Description	Packaging
108891	Bulb #193	Bargman/Wesbar Bulk
30-90-157	Bulb #1157, Double Filament	Bargman/Wesbar Bulk
2423286	Lens, Tail Light	Bargman/Wesbar Bulk
2423297	Lens, Red, Clearance/Side Marker	Bargman/Wesbar Bulk
54504-001	Protective Tail Light Bracket	Wesbar Packaging
54504-003	Protective Tail Light Bracket - Pair	Wesbar Packaging



MAGNETIC TOW LIGHT KIT

- 4-Flat hookup
- Mounts in any position vertically or horizontally
- Sealed, watertight housing
- 26' connector
- Plastic carrying case included

Part No.	Description	Packaging
18148	Magnetic Tow Light Kit (Plastic Carrying Case)	Tow Ready Bulk

PEDESTAL MOUNT TAIL LIGHTS

This combination signal light requires a 1/2" hole for stud mounting. All mounting hardware included. For easy installation the lights feature prewired supply wires and are self-grounding. Red or amber snap-on acrylic lens and black acrylic cover. Meets FMVSS/CMVSS 108 requirements and meets ASABE 4 Candle Power to the side amber light requirements.

4.28" dia. x 2.16"



Part No.	Description	Packaging
2423273	Double Face: Amber Marker/Turn - Amber Marker/Turn	Bargman/Wesbar Bulk
2423274	Double Face: Red Stop/Tail/Turn - Amber Marker/Turn	Bargman/Wesbar Bulk
2423275	Single Face: Red Stop/Tail/Turn - Black	Bargman/Wesbar Bulk

REPLACEMENT PARTS

Part No.	Description	Packaging
30-90-156	Bulb #1156, Single Filament	Bargman/Wesbar Bulk
30-90-157	Bulb #1157, Double Filament	Bargman/Wesbar Bulk

NOTE: Tail Lights, Clearance/Side Marker Lights and ID Light Bars approved for trailer accessory and towing application use. Contact your Horizon Global Representative for details.

WATERPROOF/SEALED RECESSED TAIL LIGHTS #01 SERIES



Hermetically sealed lens prevents corrosion contributed by salt and rain. Structurally immune to extreme heat and cold. Lenses meet FMVSS/CMVSS 108 requirements. Rubber grommet and three wire pigtail can be purchased separately or as a kit.

4 1/4" dia. x 2 1/16" depth; Cutout: 1) 4 9/16" +/- 1/32" w/grommet when using steel 16 ga. or thicker, 2) 4 1/2" +/- 1/32" w/grommet when using fiberglass or 18 ga. or thinner steel.

Part No.	Description	Packaging
44-01-031	Red Stop/Tail/Turn Light w/Grommet w/Standard Pigtail	Bargman Bagged

REPLACEMENT PARTS

Part No.	Description	Packaging
40-01-001	Red Stop/Tail/Turn Light	Bargman/Wesbar Bulk
44-01-001	Red Stop/Tail/Turn Light	Bargman Bagged
40-01-003	Clear Backup Light	Bargman/Wesbar Bulk
40-00-003	3 Wire Pigtail w/12" Wire Lead	Bargman/Wesbar Bulk
44-00-003	3 Wire Pigtail w/12" Wire Lead	Bargman Bagged
40-00-004	3 Wire 90° Pigtail w/12" Wire Lead	Bargman/Wesbar Bulk
719063	3 Wire 90° Pigtail w/12" Wire Lead	Wesbar Packaging
40-01-020	4" Round Grommet	Bargman/Wesbar Bulk
44-01-020	4" Round Grommet	Bargman Bagged

WATERPROOF/SEALED RECESSED TAIL LIGHTS #06 SERIES



Oval design allows for installation in narrower channels. Hermetically sealed lens prevents corrosion contributed by salt and rain. Structurally immune to extreme heat and cold. Lenses meet FMVSS/CMVSS 108 requirements. Rubber grommet and three wire pigtail can be purchased separately or as a kit. Mounting bracket of 11 ga. steel available separately.

6 1/2" x 2 1/4" x 2 3/8" depth, Cutout: 6 3/4" x 2 1/2"

Part No.	Description	Packaging
413560	Red Stop/Tail/Turn Light w/Grommet w/Standard Pigtail	Bargman/Wesbar Bulk
44-06-031	Red Stop/Tail/Turn Light w/Grommet w/Standard Pigtail	Bargman Bagged
403080	Red Stop/Tail/Turn Light w/Grommet w/Standard Pigtail	Wesbar Packaging
44-06-041	Red Stop/Tail/Turn Light w/Grommet w/90° Pigtail	Bargman Bagged
44-06-032	Amber Turn Light w/Grommet w/Standard Pigtail	Bargman Bagged
44-06-042	Amber Turn Light w/Grommet w/90° Pigtail	Bargman Bagged

REPLACEMENT PARTS

Part No.	Description	Packaging
40-06-001	Red Stop/Tail/Turn Light	Bargman/Wesbar Bulk
44-06-001	Red Stop/Tail/Turn Light	Bargman Bagged
403085	Red Stop/Tail/Turn Light	Wesbar Packaging
40-06-002	Amber Turn Light	Bargman/Wesbar Bulk
44-06-002	Amber Turn Light	Bargman Bagged
40-00-003	3 Wire Pigtail w/12" Wire Lead	Bargman/Wesbar Bulk
44-00-003	3 Wire Pigtail w/12" Wire Lead	Bargman Bagged
40-00-004	3 Wire 90° Pigtail w/12" Wire Lead	Bargman/Wesbar Bulk
719063	3 Wire 90° Pigtail w/12" Wire Lead	Wesbar Packaging
40-06-020	6" Oval Grommet	Bargman/Wesbar Bulk
44-06-020	6" Oval Grommet	Bargman Bagged
416088	6" Oval Grommet	Wesbar Packaging
108119	6" Oval Mounting Bracket	Bargman/Wesbar Bulk
34-108119	6" Oval Mounting Bracket	Bargman Bagged
106873	6" Oval Mounting Bracket	Wesbar Packaging
401591	6" Oval Grommet and 3 Wire 90° Pigtail	Wesbar Packaging

NOTE: Tail Lights, Clearance/Side Marker Lights and ID Light Bars approved for trailer accessory and towing application use. Contact your Horizon Global Representative for details.





WATERPROOF OVER 80" 3X8 LOW PROFILE TAIL LIGHTS 

Featuring a reliable waterproof design, these lights have a bulb replaceable capsule that protects the bulbs from corrosion and thermal shock but still allows for easy access for bulb replacement. These lights meet FMVSS/CMVSS 108 requirements for trailers over 80" wide when properly mounted.

8.03" x 2.94" x 2.83"

Part No.	Description	Packaging
006554	7-Function, Right/Curbside, Two Supply Wires and Ring Terminal Ground	Bargman/Wesbar Bulk
403076	7-Function, Right/Curbside, Two Supply Wires and Ring Terminal Ground	Wesbar Packaging
006504	8-Function, Left/Roadside, Two Supply Wires and Ring Terminal Ground	Bargman/Wesbar Bulk
403026	8-Function, Left/Roadside, Two Supply Wires and Ring Terminal Ground	Wesbar Packaging
106411	7-Function, Right/Curbside, Trailer Ground Connection w/ Molded 2-Way Plug and Ring Terminal Ground	Bargman/Wesbar Bulk
106410	8-Function, Left/Roadside, Trailer Ground Connection w/ Molded 2-Way Plug and Ring Terminal Ground	Bargman/Wesbar Bulk



The kit comes complete with two tail lights, two sealed amber surface mount clearance/side marker lights with reflex lens, 25' trailer wiring harness cable with molded four prong plug, 4' four wire car wiring harness cable with molded 4-way plug plus license plate bracket.

Part No.	Description	Packaging
007539	Trailer Light Kit w/25' Wire Harness	Bargman/Wesbar Bulk
007509	Trailer Light Kit w/25' Wire Harness	Wesbar Packaging

REPLACEMENT PARTS

Part No.	Description	Packaging
108891	Bulb #193	Bargman/Wesbar Bulk
30-84-057	Bulb #2057, Double Filament	Bargman/Wesbar Bulk
102641	Lens Red, Tail Light	Bargman/Wesbar Bulk
102639	Lens Red, Clearance/Side Marker	Bargman/Wesbar Bulk
90-03-336	Lens Set Red, (2) Tail Light and (2) Clearance/Side Marker w/ Screws	Bargman Bagged
403336	Lens Set Red, (2) Tail Light and (2) Clearance/Side Marker w/ Screws	Wesbar Packaging
003101	Clearance Light Amber w/Black Stud Mount Base	Bargman/Wesbar Bulk
203111	Clearance Light Amber w/Black Stud Mount Base	Wesbar Packaging
003201	License Plate Bracket	Bargman/Wesbar Bulk
003211	License Plate Bracket	Wesbar Packaging
002301	4' Wiring Harness w/4-Way Flat Car End	Bargman/Wesbar Bulk
707275	4' Wiring Harness w/4-Way Flat Car End	Wesbar Packaging
108825	25' Wiring Harness w/4-Way Flat Trailer End	Bargman/Wesbar Bulk
707261	25' Wiring Harness w/4-Way Flat Trailer End	Wesbar Packaging

BULB CAPSULE 

Capsule protects bulbs from corrosion, thermoshock and environmental failure. Replacement for capsules used on a variety of Wesbar marine over 80" low profile and wrap-around tail lights. Available in permanently sealed or bulb replaceable version.

Part No.	Description	Packaging
403356*	Bulb Capsule - Bulb Replaceable	Wesbar Packaging

**Note: This product is only applicable for Wesbar lamps produced prior to 2010.*

NOTE: Tail Lights, Clearance/Side Marker Lights and ID Light Bars approved for trailer accessory and towing application use. Contact your Horizon Global Representative for details.





SUBMERSIBLE UNDER 80" TAIL LIGHTS 

These lights are ideal for boat and PWC trailers less than 80" wide. Fully gasketed, screw on main and side marker lens allow for easy bulb replacement. Universal 2" on-center stud mount.

5.25" x 4.66" x 3.76" overall height

Part No.	Description	Packaging
2423056	6-Function, Right/Curbside	Bargman/Wesbar Bulk
2523073	6-Function, Right/Curbside	Wesbar Packaging
2423006	7-Function, Left/Roadside	Bargman/Wesbar Bulk
2523023	7-Function, Left/Roadside	Wesbar Packaging



This kit comes complete with two pre-wired tail lights, 25' trailer wiring harness cable with molded four prong plug, 4' four wire car wiring harness cable with molded 4-way plug plus license plate bracket.

Part No.	Description	Packaging
2527511	Trailer Light Kit w/25' Wire Harness	Wesbar Packaging

REPLACEMENT PARTS

Part No.	Description	Packaging
108891	Bulb #193	Bargman/Wesbar Bulk
30-90-157	Bulb #2057, Double Filament	Bargman/Wesbar Bulk
2423286	Lens Red, Tail Light	Bargman/Wesbar Bulk
54001	Lens Red, Tail Light w/Screws (Bagged)	Bargman/Wesbar Bulk
2423287	Lens Red, Clearance/Side Marker	Bargman/Wesbar Bulk
54002	Lens Red, Clearance/Side Marker w/Screws (Bagged)	Bargman/Wesbar Bulk

SUBMERSIBLE OVER 80" TAIL LIGHTS 



These lights are ideal for boat and PWC trailers over 80" wide. Fully gasketed, screw on main and side marker lenses allow for easy bulb replacement. Universal 2" on-center stud mount. These lights meet FMVSS/CMVSS 108 requirements for trailers over 80" wide when properly mounted. Prewired for easy installation.

6.29" x 4.66" x 3.76" overall height

Part No.	Description	Packaging
2423058	7-Function, Right/Curbside	Bargman/Wesbar Bulk
2523074	7-Function, Right/Curbside	Wesbar Packaging
2423008	8-Function, Left/Roadside	Bargman/Wesbar Bulk
2523024	8-Function, Left/Roadside	Wesbar Packaging

REPLACEMENT PARTS

Part No.	Description	Packaging
108891	Bulb #193	Bargman/Wesbar Bulk
30-90-157	Bulb #1157, Double Filament	Bargman/Wesbar Bulk
2423286	Lens Red, Tail Light	Bargman/Wesbar Bulk
54001	Lens Red, Tail Light w/Screws (Bagged)	Bargman/Wesbar Bulk
2423297	Lens Red, Clearance/Side Marker	Bargman/Wesbar Bulk
54003	Lens Red, Clearance/Side Marker w/Screws (Bagged)	Bargman/Wesbar Bulk

NOTE: Tail Lights, Clearance/Side Marker Lights and ID Light Bars approved for trailer accessory and towing application use. Contact your Horizon Global Representative for details.





SUBMERSIBLE OVER 80" 4X6 LOW PROFILE TAIL LIGHTS 

Unique, compact size and shape allows these lights to fit where space is limited. The lens is sonically-sealed to the base providing a "bell jar," making this lamp fully submersible with easily replaceable bulbs. These lights meet FMVSS/CMVSS 108 requirements for trailers over 80" wide when properly mounted. Pre-wired with 2-way molded plugs and ring terminal ground for easy installation.
6" x 3 1/2" x 2 1/4"

Part No.	Description	Packaging
423075	6-Function, Right/Curbside	Bargman/Wesbar Bulk
403075	6-Function, Right/Curbside	Wesbar Packaging
423025	7-Function, Left/Roadside	Bargman/Wesbar Bulk
403025	7-Function, Left/Roadside	Wesbar Packaging

The kit comes complete with two tail lights, two amber clearance/side marker lights with reflex lens, 20' trailer wiring harness cable with molded four prong plug, 4' four wire car wiring harness cable with molded 4-way plug plus license plate bracket.

Part No.	Description	Packaging
417515	Trailer Light Kit w/20' Wire Harness	Bargman/Wesbar Bulk
407515	Trailer Light Kit w/20' Wire Harness	Wesbar Packaging

REPLACEMENT PARTS

Part No.	Description	Packaging
108891	Bulb #193	Bargman/Wesbar Bulk
30-90-157	Bulb #1157, Double Filament	Bargman/Wesbar Bulk
223117	Clearance/Side Marker, Amber, Stud Mount w/Reflex	Bargman/Wesbar Bulk
203117	Clearance/Side Marker, Amber, Stud Mount w/Reflex	Wesbar Packaging
003328	Lens Amber, Clearance/Side Marker	Bargman/Wesbar Bulk
90-03-328	Lens Amber, Clearance/Side Marker w/Screw	Bargman Bagged
003338	Lens Amber, Clearance/Side Marker w/Screw	Wesbar Packaging
003201	License Plate Bracket	Bargman/Wesbar Bulk
003211	License Plate Bracket	Wesbar Packaging
002301	4' Wiring Harness w/4-Way Flat Car End	Bargman/Wesbar Bulk
707275	4' Wiring Harness w/4-Way Flat Car End	Wesbar Packaging
002220	20' Wiring Harness w/4-Way Flat Trailer End	Bargman/Wesbar Bulk

NOTE: Tail Lights, Clearance/Side Marker Lights and ID Light Bars approved for trailer accessory and towing application use. Contact your Horizon Global Representative for details.



LED WORK LIGHTS

LED work lights perfect for exterior use in AG, horse, livestock, RV, industrial and racing applications. Environmentally sealed design with aluminum housing and stainless steel mounting stud. High power, true white 9-36V, 10W light emission. Rectangular version with 10 LED diodes, circular model has 8 LED diodes.

Circular: 4.5" dia. x 1.5" depth
 Rectangular: 4" x 4" x 1.5" depth



Part No.	Description	Packaging
54209-001	Circular LED Light, 8 Diodes	Bargman/Wesbar Bulk
54209-002	Rectangular LED Light, 10 Diodes	Bargman/Wesbar Bulk
54209-025	Rectangular LED Light, 10 Diodes w/Molded 2-Way Plug	Bargman/Wesbar Bulk

LED WORK LIGHTS WITH COILED CORD & MAGNETIC BASE

LED work lights perfect for exterior use in AG, horse, livestock, RV, industrial and racing applications. Environmentally sealed design with 19' extended coiled cord. Magnetic base, with protective film, secures in high vibration conditions in a vertical or horizontal position. Power adapter for 12V outlet with separate on/off switch. High power, true white 9-36V, 10W light emission. Rectangular version with 10 LED diodes, circular model has 8 LED diodes.

Circular: 4.5" dia. x 1.875" depth
 Rectangular: 4" x 4" x 1.75" depth



Part No.	Description	Packaging
54209-017	Circular LED Light, w/Cord, Magnetic Base, 8 Diodes	Wesbar Packaging
54209-018	Rectangular LED Light, w/Cord, Magnetic Base, 10 Diodes	Wesbar Packaging

NOTE: Tail Lights, Clearance/Side Marker Lights and ID Light Bars approved for trailer accessory and towing application use. Contact your Horizon Global Representative for details.

WATERPROOF LAUNCH LIGHTS 

Designed to illuminate the back or side of trailers, these lights help to launch and load under low light conditions (requires five-wire trailer harness). Lights are powerful, yet small enough to fit in tight areas and can be either grommet or snap-lock base-mounted. Lens and base are constructed of extra-tough polycarbonate to resist damage.



REPLACEMENT PARTS

Part No.	Description	Packaging
40-37-020	Black 2" Snap-Lock Base, Self Grounding w/ Single Black Wire	Bargman/Wesbar Bulk
44-37-020	Black 2" Snap-Lock Base, Self Grounding w/ Single Black Wire	Bargman/Wesbar Bulk
106289	Black 2" Snap-Lock Base, Self Grounding	Bargman/Wesbar Bulk
108297	Black 2" Snap-Lock Base, Open Back	Wesbar Packaging
106293	Chrome 2" Snap-Lock Base, Self-Grounding	Bargman/Wesbar Bulk
34-106293	Chrome 2" Snap-Lock Base, Self-Grounding	Bargman Bagged
221588	Grommet, Rectangular	Bargman/Wesbar Bulk
40-00-002	2 Wire Pigtail w/6" Wire Lead	Wesbar Packaging
44-00-002	2 Wire Pigtail w/6" Wire Lead	Bargman/Wesbar Bulk
108663	2 Wire Pigtail w/18" Wire Lead	Wesbar Packaging
34-108663	2 Wire Pigtail w/18" Wire Lead	Bargman/Wesbar Bulk

WATERPROOF COURTESY LIGHTS 

Sealed lights with #193 bulbs are ideal for a variety of interior and exterior applications. Lens and base are constructed of extra-tough polycarbonate to resist damage.



2.15" x 1.125" x 1.035" w/.7" depth

Part No.	Description	Packaging
003232	Courtesy Light w/Self-Grounding Stud Mount, Single Wire w/ Molded Barrel	Bargman/Wesbar Bulk

WATERPROOF LED 6" OVAL GROMMET MOUNT COURTESY LIGHT 

Waterproof 10 diode courtesy/utility light. Horizontal and vertical mount applications. LED provides longer life, brighter more focused illumination and less current draw than incandescent lamps. Grommet and 3 prong wiring pigtail available separately.



6.42" x 2.25" x 1.00 w/.77" depth

Part No.	Description	Packaging
54005	LED Oval Courtesy Light Clear w/Grommet w/3 Wire 90° Pigtail	Bargman/Wesbar Bulk
273560	LED Oval Courtesy Light Clear	Wesbar Packaging

ACCESSORY PARTS

Part No.	Description	Packaging
40-00-003	3 Wire Pigtail w/12" Wire Lead	Bargman/Wesbar Bulk
44-00-003	3 Wire Pigtail w/12" Wire Lead	Bargman Bagged
40-00-004	3 Wire 90° Pigtail w/12" Wire Lead	Bargman/Wesbar Bulk
719063	3 Wire 90° Pigtail w/12" Wire Lead	Wesbar Packaging
40-06-020	6" Oval Grommet	Bargman/Wesbar Bulk
44-06-020	6" Oval Grommet	Bargman Bagged
416088	6" Oval Grommet	Wesbar Packaging
108119	6" Oval Mounting Bracket	Bargman/Wesbar Bulk
34-108119	6" Oval Mounting Bracket	Bargman Bagged
106873	6" Oval Mounting Bracket	Wesbar Packaging
401591	6" Oval Grommet & 3 Wire 90° Pigtail	Wesbar Packaging





40-00-002
44-00-002

WATERPROOF LED 2" ROUND CLEARANCE/SIDE MARKER LIGHTS #30 SERIES - REPLACEMENT PARTS

Waterproof LED clearance/side marker light with grommet designed for quick and easy installation. Flush mount rubber grommet and two wire pigtail.

Module only: 2" dia. x .97" height

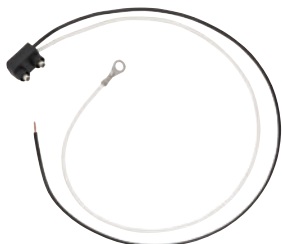

108663
34-108663

Part No.	Description	Packaging
40-00-002	2 Wire Pigtail w/6" Wire Lead	Bargman/Wesbar Bulk
44-00-002	2 Wire Pigtail w/6" Wire Lead	Bargman Bagged
108663	2 Wire Pigtail w/18" Wire Lead	Bargman/Wesbar Bulk
34-108663	2 Wire Pigtail w/18" Wire Lead	Bargman Bagged
40-30-020	2" Round Grommet	Bargman/Wesbar Bulk
44-30-020	2" Round Grommet	Bargman Bagged
401589	2" Round Grommet and 2 Wire Pigtail w/6" Wire Lead	Wesbar Packaging



40-30-020
44-30-020

WATERPROOF LED 2 1/2" ROUND CLEARANCE/SIDE MARKER LIGHTS #31 SERIES WITH/ WITHOUT REFLEX LENS - REPLACEMENT PARTS

Waterproof LED clearance/side marker light with grommet designed for quick and easy installation. Flush mount rubber grommet and two wire pigtail. Available with and without reflex lens.

Module only: 2.5" x .98" height



401589

Part No.	Description	Packaging
40-00-002	2 Wire Pigtail w/6" Wire Lead	Bargman/Wesbar Bulk
44-00-002	2 Wire Pigtail w/6" Wire Lead	Bargman Bagged
108663	2 Wire Pigtail w/18" Wire Lead	Bargman/Wesbar Bulk
34-108663	2 Wire Pigtail w/18" Wire Lead	Bargman Bagged
221088	2 1/2" Round Open Back Heavy Duty Grommet	Bargman/Wesbar Bulk



221088

NOTE: Tail Lights, Clearance/Side Marker Lights and ID Light Bars approved for trailer accessory and towing application use. Contact your Horizon Global Representative for details.





WATERPROOF LED HI INTENSITY MICRO CLEARANCE/SIDE MARKER LIGHTS 

Waterproof Hi Intensity LED clear, red and amber micro clearance/side marker light. The red and amber lights are FMVSS-108 PC rated. The clear style is ideal for auxiliary and decorative lighting. Self contained grommet and pre-wired with sealed 12" wire pigtail.

.75" light dia. x .5" height, 1" dia. w/grommet

Note: Recommended hole size is .75" and the recommended material thickness is between .0625" and .125".

Part No.	Description	Packaging
54201-006	Hi Intensity Micro Clearance Light LED Amber	Bargman/Wesbar Bulk
54201-003	Hi Intensity Micro Clearance Light LED Amber	Bargman Bagged
54201-007	Hi Intensity Micro Clearance Light LED Red	Bargman/Wesbar Bulk
54201-004	Hi Intensity Micro Clearance Light LED Red	Bargman Bagged
54201-008	Hi Intensity Micro Light LED Clear	Bargman/Wesbar Bulk
54201-005	Hi Intensity Micro Light LED Clear	Bargman Bagged

WATERPROOF LED CLEARANCE/SIDE MARKER LIGHTS #37 SERIES 

Waterproof LED clearance/side marker light designed for easy installation. Snap lock base mount. Tested and certified to FMVSS/CMVSS 108 side marker/clearance light requirements. P2 rated.

Module Only: 2.60" x 1.20" x 1.03" overall height

Module w/Base: 2-7/8" x 1-1/2" x 1"

Part No.	Description	Packaging
47-37-031	Clearance Light LED #37 Red w/Black Base	Bargman Bagged
401581	Clearance Light LED #37 Red w/Black Base	Wesbar Packaging
47-37-032	Clearance Light LED #37 Amber w/Black Base	Bargman Bagged
401580	Clearance Light LED #37 Amber w/Black Base	Wesbar Packaging
47-37-005	Clearance Light Module LED #37 Red, PC Rated When Properly Mounted	Bargman/Wesbar Bulk
47-37-006	Clearance Light Module LED #37 Amber, PC Rated When Properly Mounted	Bargman/Wesbar Bulk

ACCESSORY/REPLACEMENT PARTS



Part No.	Description	Packaging
47-37-001	Clearance Light Module LED #37 Red	Bargman/Wesbar Bulk
42-37-401	Clearance Light Module LED #37 Red	Bargman Clam
47-37-401	Clearance Light Module LED #37 Red	Bargman Bagged
47-37-002	Clearance Light Module LED #37 Amber	Bargman/Wesbar Bulk
42-37-402	Clearance Light Module LED #37 Amber	Bargman Clam
47-37-402	Clearance Light Module LED #37 Amber	Bargman Bagged
40-37-020	Black 2" Snap-Lock Base, Self-Grounding w/Single Black Wire	Bargman/Wesbar Bulk
44-37-020	Black 2" Snap-Lock Base, Self-Grounding w/Single Black Wire	Bargman Bagged
106289	Black 2" Snap-Lock Base, Self-Grounding	Bargman/Wesbar Bulk
108297	Black 2" Snap-Lock Base, Open Back	Bargman/Wesbar Bulk
106293	Chrome 2" Snap-Lock Base, Self-Grounding	Bargman/Wesbar Bulk
34-106293	Chrome 2" Snap-Lock Base, Self-Grounding	Bargman Bagged
106294	Chrome 2" Snap-Lock Base, Open Back	Bargman/Wesbar Bulk
221588	Grommet Rectangular	Bargman/Wesbar Bulk
40-00-002	2 Wire Pigtail w/6" Wire Lead	Bargman/Wesbar Bulk
44-00-002	2 Wire Pigtail w/6" Wire Lead	Bargman Bagged
108663	2 Wire Pigtail w/18" Wire Lead	Bargman/Wesbar Bulk
34-108663	2 Wire Pigtail w/18" Wire Lead	Bargman Bagged





WATERPROOF LED CLEARANCE/SIDE MARKER LIGHT WITH REFLEX LENS

Waterproof LED clearance/side marker "tongue" lights. Excellent for boat trailer tongue lighting. Snap-on lens with black or white bases. Two wire construction with either notched wires or molded single bullet and barrel. Tested to FMVSS/CMVSS 108 requirements. P2 rated.

2.62" x 1.83" x .83"

Part No.	Description	Packaging
47-222012	Clearance Light LED Amber w/Reflex w/Black Base - BULLET SUPPLY, BARREL GROUND	Bargman/Wesbar Bulk
47-222014	Clearance Light 1 Diode LED Red w/Reflex w/White Base - NOTCHED SUPPLY & GROUND WIRES	Bargman/Wesbar Bulk
47-222015	Clearance Light 1 Diode LED Amber w/Reflex w/White Base - NOTCHED SUPPLY & GROUND WIRES	Bargman/Wesbar Bulk

REPLACEMENT PARTS

Part No.	Description	Packaging
222012*	Lens Amber	Bargman/Wesbar Bulk

*Note: Replacement lens will increase the dimension of existing unit by 1/4".



WATERPROOF LED CLEARANCE/SIDE MARKER LIGHTS

FMVSS/CMVSS 108 compliant waterproof LED clearance/side marker lights with 2 diodes. One piece design with thru-lens mounting holes. 18" two wire construction. P2/P3 rated.

2.6" x 1.1" x .75" height (mounting: (2) .25" dia. hole - 1.9" centers)

Part No.	Description	Packaging
47-106853	Clearance Light LED Amber	Bargman/Wesbar Bulk
54201-001	Clearance Light LED Amber w/Chrome Bezel	Bargman Bagged
47-106854	Clearance Light LED Clear Lens w/Amber Diodes	Bargman/Wesbar Bulk
47-107047	Clearance Light LED Red	Bargman/Wesbar Bulk
54201-002	Clearance Light LED Red w/Chrome Bezel	Bargman Bagged
47-107048	Clearance Light LED Clear Lens w/Red Diodes	Bargman/Wesbar Bulk

ACCESSORY PARTS

Part No.	Description	Packaging
47-106020	Chrome Bezel (3.23" x 1.73" x .47" height)	Bargman/Wesbar Bulk

NOTE: Tail Lights, Clearance/Side Marker Lights and ID Light Bars approved for trailer accessory and towing application use. Contact your Horizon Global Representative for details.



WATERPROOF LED CLEARANCE/SIDE MARKER LIGHTS



Waterproof LED clearance/side marker lights. One piece design with thru-lens mounting holes. Single stud on base, 1/4" hole required, provides self-ground. Features wire harness with either one or two wire configurations that includes notched wires or molded single bullets and/or barrels. P2/P3 rated.

2.64" x 1.14" x .97" w/.43" depth (mounting: (2) .25 dia. hole - 1.9" centers)



42-99-402

Part No.	Description	Packaging
47-106851	Clearance Light LED Amber w/Self-Ground Stud, 12" Brown Wire	Bargman/Wesbar Bulk
42-99-402	Clearance Light LED Amber w/Self-Ground Stud, 12" Brown Wire	Bargman Clam
47-99-402	Clearance Light LED Amber w/Self-Ground Stud, 12" Brown Wire	Bargman Bagged
47-107043	Clearance Light LED Red w/Self-Ground Stud, 12" Brown Wire	Bargman/Wesbar Bulk
42-99-401	Clearance Light LED Red w/Self-Ground Stud, 12" Brown Wire	Bargman Clam
47-99-401	Clearance Light LED Red w/Self-Ground Stud, 12" Brown Wire	Bargman Bagged
47-106852	Clearance Light LED Amber w/Self-Ground Stud, 162" Brown Bullet Pigtail	Bargman/Wesbar Bulk
47-106857	Clearance Light LED Amber w/Self-Ground Stud, 162" Brown Bullet/White Barrel Pigtail	Bargman/Wesbar Bulk
47-107044	Clearance Light LED Red w/Self-Ground Stud, 96" Brown Bullet/Brown Barrel Pigtail	Bargman/Wesbar Bulk
47-107046	Clearance Light LED Red w/Self-Ground Stud, 96" Brown Bullet & Barrel/White Bullet & Barrel Pigtail	Bargman/Wesbar Bulk

WATERPROOF LED CLEARANCE/SIDE MARKER LIGHTS



One piece waterproof LED clearance/side marker lights designed for grommet mounting. Two wire pigtail features 6" or 18" wire leads with supply wire and ring terminal ground. Pigtail and grommet available separately. P2 rated.

2.61" x 1.22" x .79"



Part No.	Description	Packaging
47-203667	Clearance Light Module LED Amber	Bargman/Wesbar Bulk
47-203668	Clearance Light Module LED Red	Bargman/Wesbar Bulk

ACCESSORY PARTS

Part No.	Description	Packaging
221588	Grommet, Rectangular	Bargman/Wesbar Bulk
40-00-002	2 Wire Pigtail w/6" Wire Lead	Bargman/Wesbar Bulk
44-00-002	2 Wire Pigtail w/6" Wire Lead	Bargman Bagged
108663	2 Wire Pigtail w/18" Wire Lead	Bargman/Wesbar Bulk
34-108663	2 Wire Pigtail w/18" Wire Lead	Bargman Bagged

WATERPROOF LED CLEARANCE/SIDE MARKER LIGHTS #99 SERIES



Waterproof mini LED clearance/side marker light with single wire, 12" minimum. Self-grounding stud mounting with 1/4" required hole. Includes type 302 stainless steel hardware. Meets FMVSS/CMVSS 108 requirements. PC rated when properly mounted.

2.16" x 1.16" x 1.03" w/.72" depth



Part No.	Description	Packaging
47-99-005	Clearance Light LED #99 Red	Bargman/Wesbar Bulk
401566	Clearance Light LED #99 Red	Wesbar Packaging
47-99-006	Clearance Light LED #99 Amber	Bargman/Wesbar Bulk
401565	Clearance Light LED #99 Amber	Wesbar Packaging

NOTE: Tail Lights, Clearance/Side Marker Lights and ID Light Bars approved for trailer accessory and towing application use. Contact your Horizon Global Representative for details.





LED CLEARANCE/SIDE MARKER LIGHTS #59 SERIES WITH REFLEX LENS

Rugged ABS base with LED light engine assembled directly into reflectorized acrylic lens. LED light engine consists of 2 LED lights that are mounted into a circuit board that is then potted and sealed to protect against water and other elements. 4" x 2" x 1 1/32" w/5/8" depth

Part No.	Description	Packaging
47-59-001	Clearance Light LED #59 Red w/White Base w/Pigtail	Bargman/Wesbar Bulk
42-59-401	Clearance Light LED #59 Red w/White Base w/Pigtail	Bargman Clam
47-59-401	Clearance Light LED #59 Red w/White Base w/Pigtail	Bargman Bagged
47-59-002	Clearance Light LED #59 Amber w/White Base w/Pigtail	Bargman/Wesbar Bulk
42-59-402	Clearance Light LED #59 Amber w/White Base w/Pigtail	Bargman Clam
47-59-402	Clearance Light LED #59 Amber w/White Base w/Pigtail	Bargman/Wesbar Bulk

REPLACEMENT PARTS

Part No.	Description	Packaging
47-59-010	Lens Module LED #59 Red	Bargman/Wesbar Bulk
42-59-410	Lens Module LED #59 Red	Bargman Clam
47-59-410	Lens Module LED #59 Red	Bargman Bagged
47-59-012	Lens Module LED #59 Amber	Bargman/Wesbar Bulk
42-59-412	Lens Module LED #59 Amber	Bargman Clam
47-59-412	Lens Module LED #59 Amber	Bargman/Wesbar Bulk



LED MODULE KITS CLEARANCE/SIDE MARKER LIGHTS #59 SERIES WITH REFLEX LENS

#59 Series LED Upgrade Kits are designed to convert Bargman #59 Incandescent Clearance/Side Marker Lights to LED WITHOUT having to remove the base. Simply remove the lens and the incandescent bulb and plug in the LED light engine (lens and LED lights).

Part No.	Description	Packaging
47-59-010	Upgrade Kit LED #59 Red	Bargman/Wesbar Bulk
42-59-410	Upgrade Kit LED #59 Red	Bargman Clam
47-59-410	Upgrade Kit LED #59 Red	Bargman Bagged
47-59-012	Upgrade Kit LED #59 Amber	Bargman/Wesbar Bulk
42-59-412	Upgrade Kit LED #59 Amber	Bargman Clam
47-59-412	Upgrade Kit LED #59 Amber	Bargman/Wesbar Bulk

LED CLEARANCE/SIDE MARKER LIGHT KITS #58 SERIES

LED oblong clearance/side marker light with snap lock base mount. 4" x 2" x 1"

Part No.	Description	Packaging
47-58-031	Clearance Light LED #58 Red w/Pigtail, w/ White Base	Bargman Bagged
47-58-032	Clearance Light LED #58 Amber w/Pigtail, w/ White Base	Bargman Bagged
47-58-001	Clearance Light LED #58 Red w/ White Base	Bargman/Wesbar Bulk
401586	Clearance Light LED #58 Red w/ White Base	Wesbar Packaging
47-58-002	Clearance Light LED #58 Amber w/ White Base	Bargman/Wesbar Bulk
401585	Clearance Light LED #58 Amber w/ White Base	Wesbar Packaging

REPLACEMENT PARTS

Part No.	Description	Packaging
40-00-005	Pigtail	Bargman/Wesbar Bulk

NOTE: Tail Lights, Clearance/Side Marker Lights and ID Light Bars approved for trailer accessory and towing application use. Contact your Horizon Global Representative for details.

LED CLEARANCE/SIDE MARKER LIGHTS #38 SERIES

LED clearance/side marker light designed for easy installation. Snap lock base mount. Fully tested and certified to FMVSS/CMVSS 108 side marker/clearance light requirements. P2 rated.

Module Only: 3.93" x 1.22" x 1.02" overall height

Fender Mount Module Only: 3.95" x 1.24" x 1.038" overall height



Part No.	Description	Packaging
42-38-033	Clearance Light LED #38 Red w/Black Base w/Pigtail	Bargman Clam
47-38-033	Clearance Light LED #38 Red w/Black Base w/Pigtail	Bargman Bagged
401583	Clearance Light LED #38 Red w/Black Base w/Pigtail	Wesbar Packaging
42-38-034	Clearance Light LED #38 Amber w/Black Base w/Pigtail	Bargman Clam
47-38-034	Clearance Light LED #38 Amber w/Black Base w/Pigtail	Bargman Bagged
42-38-035	Clearance Light LED #38 Red w/Black Base, Self-Grounding	Bargman Clam
401582	Clearance Light LED #38 Amber w/Black Base w/Pigtail	Wesbar Packaging
47-38-004	Clearance Light LED #59 Amber w/White Base w/Pigtail	Bargman/Wesbar Bulk

REPLACEMENT PARTS

Part No.	Description	Packaging
47-38-001	Clearance Light Module LED #38 Red	Bargman/Wesbar Bulk
47-38-401	Clearance Light Module LED #38 Red	Bargman Bagged
47-38-002	Clearance Light Module LED #38 Amber	Bargman/Wesbar Bulk
47-38-402	Clearance Light Module LED #38 Amber	Bargman Bagged
40-38-020	Black Base w/Wire Assembly, Self-Grounding w/Single Black Wire	Bargman/Wesbar Bulk
40-38-025	Black Base w/2 Wires	Bargman/Wesbar Bulk

LED CLEARANCE/SIDE MARKER LIGHT 2 1/2" ROUND

Round clearance/side marker light with surface mount design. Two wire construction simplifies grounding. These lights meet FMVSS-108 and CMVSS-108 requirements for P2 and PC side marker clearance functions when properly mounted.

2 3/4" Round



Part No.	Description	Packaging
54201-015	LED Red Clearance Light with Mounting Flange	Bargman Bulk
54201-016	LED Red Clearance Light with Mounting Flange	Bargman Clam
54201-017	LED Amber Clearance Light with Mounting Flange	Bargman Bulk
54201-018	LED Amber Clearance Light with Mounting Flange	Bargman Clam

LED WRAP-AROUND CLEARANCE/SIDE MARKER LIGHTS #86 SERIES

This 90 degree LED wrap-around light meets lighting requirements for side markers and clearance lights and doubles as a Class "A" side-reflex reflector. The light meets FMVSS/CMVSS 108 requirements.

5 3/4" X 4 3/8" X 2 3/16"



Part No.	Description	Packaging
47-86-202	LED Stop/Tail/Turn Light Lens Module Red w/Bulb Socket Plug	Bargman Clam
48-86-202	LED Stop/Tail/Turn Light Lens Module Red w/Bulb Socket Plug	Bargman Bagged

REPLACEMENT PARTS

Part No.	Description	Packaging
42-86-410	LED Wrap-Around Clearance Light Module Red	Bargman Clam
47-86-410	LED Wrap-Around Clearance Light Module Red	Bargman Bagged
42-86-412	LED Wrap-Around Clearance Light Module Amber	Bargman Clam
47-86-412	LED Wrap-Around Clearance Light Module Amber	Bargman Bagged
30-86-711	Lens #86 Red Wrap-Around	Bargman/Wesbar Bulk
34-86-711	Lens #86 Red Wrap-Around	Bargman Bagged
30-86-712	Lens #86 Amber Wrap-Around	Bargman/Wesbar Bulk
34-86-712	Lens #86 Amber Wrap-Around	Bargman Bagged
30-84-075	Marker Light Lens Screw	Bargman/Wesbar Bulk

NOTE: Tail Lights, Clearance/Side Marker Lights and ID Light Bars approved for trailer accessory and towing application use. Contact your Horizon Global Representative for details.

WATERPROOF/SEALED CLEARANCE/SIDE MARKER LIGHTS #37 SERIES

Compact rectangular light with the polycarbonate lens sonic welded to the base. Offers easy installation with self grounding base on metallic surfaces. Snaplock tabs on the lens housing secures light to base to complete the fast installation. The light complies with FMVSS/CMVSS 108 requirements for combination clearance/marker light when mounted properly. 2 1/2" x 1 1/4"



Part No.	Description	Packaging
41-37-031	Clearance Lens #37 Red w/Black Base w/Wire	Bargman Clam
44-37-031	Clearance Lens #37 Red w/Black Base w/Wire	Bargman Bagged
203293	Clearance Lens #37 Red w/Black Base w/Wire	Wesbar Packaging
41-37-032	Clearance Lens #37 Amber w/Black Base w/Wire	Bargman Clam
44-37-032	Clearance Lens #37 Amber w/Black Base w/Wire	Bargman Bagged
203292	Clearance Lens #37 Amber w/Black Base w/Wire	Wesbar Packaging
203294	Clearance Lens #37 Amber w/Chrome Base w/Wire	Wesbar Packaging
203295	Clearance Lens #37 Red w/Chrome Base w/Wire	Wesbar Packaging

REPLACEMENT PARTS

Part No.	Description	Packaging
40-37-001	Clearance Light Module #37 Red	Bargman/Wesbar Bulk
40-37-401	Clearance Light Module #37 Red	Bargman Bagged
203396	Clearance Light Module #37 Red	Wesbar Packaging
40-37-002	Clearance Light Module #37 Amber	Bargman/Wesbar Bulk
40-37-402	Clearance Light Module #37 Amber	Bargman Bagged
203395	Clearance Light Module #37 Amber	Wesbar Packaging
40-37-020	Black 2" Snap-Lock Base, Self-Grounding w/Single Black Wire	Bargman/Wesbar Bulk
44-37-020	Black 2" Snap-Lock Base, Self-Grounding w/Single Black Wire	Bargman Bagged
106289	Black 2" Snap-Lock Base Self-Grounding	Bargman/Wesbar Bulk
108297	Black 2" Snap-Lock Base Open Back	Bargman/Wesbar Bulk
106293	Chrome 2" Snap-Lock Base Self-Grounding w/Wire	Bargman/Wesbar Bulk
34-106293	Chrome 2" Snap-Lock Base Self-Grounding w/Wire	Bargman Bagged
106294	Chrome 2" Snap-Lock Base Open Back	Bargman/Wesbar Bulk
221588	Grommet Rectangular	Bargman/Wesbar Bulk
106334	Single Plug for Snap-Lock Base	Bargman/Wesbar Bulk
40-00-002	2 Wire Pigtail w/6" Wire Lead	Bargman/Wesbar Bulk
44-00-002	2 Wire Pigtail w/6" Wire Lead	Bargman Bagged
108663	2 Wire Pigtail w/18" Wire Lead	Bargman/Wesbar Bulk
34-108663	2 Wire Pigtail w/18" Wire Lead	Bargman Bagged

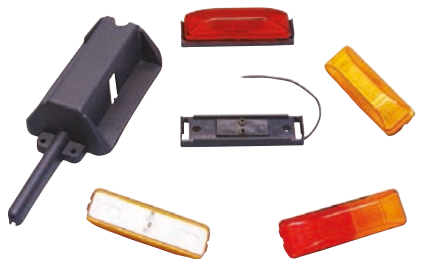

WATERPROOF/SEALED CLEARANCE/SIDE MARKER LIGHTS #38 SERIES

Double bulb rectangular light with the polycarbonate lens sonic welded to the base. This light offers easy installation with self grounding base on metallic surfaces. Snap-lock tabs on the lens housing secures light to base to complete the fast installation. The light complies with FMVSS/CMVSS 108 requirements for combination clearance/marker light when mounted properly. P2 rated. 3 13/16" x 1 1/4"

Part No.	Description	Packaging
41-38-031	Clearance Lens #38 Red w/Black Base w/Wire Assembly	Bargman Clam
44-38-031	Clearance Lens #38 Red w/Black Base w/Wire Assembly	Bargman Bagged
41-38-032	Clearance Lens #38 Amber w/Black Base w/Wire Assembly	Bargman Clam
44-38-032	Clearance Lens #38 Amber w/Black Base w/Wire Assembly	Bargman Bagged
40-38-004	Fender Mount Clearance Light Module #38 Red/Amber	Bargman/Wesbar Bulk

ACCESSORY PARTS

Part No.	Description	Packaging
40-40-120	Fender Mount Black Base for Two Lights	Bargman/Wesbar Bulk

REPLACEMENT PARTS

Part No.	Description	Packaging
40-38-001	Clearance Light Module #38 Red	Bargman/Wesbar Bulk
40-38-002	Clearance Light Module #38 Amber	Bargman/Wesbar Bulk
40-38-020	Black Base w/Wire Assembly, Self-Grounding w/Single Black Wire	Bargman/Wesbar Bulk
40-38-025	Black Base w/2 Wires	Bargman/Wesbar Bulk

NOTE: Tail Lights, Clearance/Side Marker Lights and ID Light Bars approved for trailer accessory and towing application use. Contact your Horizon Global Representative for details.





40-30-001
41-30-001
44-30-001
203381



40-30-002
41-30-002
44-30-002
203380



40-30-020
44-30-020



221088



401589



40-00-002
44-00-002



108663
34-108663

NOTE: Tail Lights, Clearance/Side Marker Lights and ID Light Bars approved for trailer accessory and towing application use. Contact your Horizon Global Representative for details.



WATERPROOF/SEALED CLEARANCE/SIDE MARKER LIGHTS #30 SERIES

Clearance/side marker light with grommet designed for quick and easy installation. Rugged ABS base that has the acrylic lens sonic welded to the base. Flush mount rubber grommet and two wire pigtail can be purchased separately or as a kit. 2" dia. x 3/4", 2 3/4" dia. w/grommet, Cutout: 2 5/16" dia

Part No.	Description	Packaging
44-30-031	Clearance Light #30 Red w/Grommet w/6" Pigtail	Bargman Bagged
44-30-032	Clearance Light #30 Amber w/Grommet w/6" Pigtail	Bargman Bagged

REPLACEMENT PARTS

Part No.	Description	Packaging
40-30-001	Clearance Light Module #30 Red	Bargman/Wesbar Bulk
41-30-001	Clearance Light Module #30 Red	Bargman Clam
44-30-001	Clearance Light Module #30 Red	Bargman Bagged
203381	Clearance Light Module #30 Red	Wesbar Packaging
40-30-002	Clearance Light Module #30 Amber	Bargman/Wesbar Bulk
41-30-002	Clearance Light Module #30 Amber	Bargman Clam
44-30-002	Clearance Light Module #30 Amber	Bargman Bagged
203380	Clearance Light Module #30 Amber	Wesbar Packaging
40-00-002	2 Wire Pigtail w/6" Wire Lead	Bargman/Wesbar Bulk
44-00-002	2 Wire Pigtail w/6" Wire Lead	Bargman Bagged
108663	2 Wire Pigtail w/18" Wire Lead	Bargman/Wesbar Bulk
34-108663	2 Wire Pigtail w/18" Wire Lead	Bargman Bagged
40-30-020	2" Round Grommet	Bargman/Wesbar Bulk
44-30-020	2" Round Grommet	Bargman Bagged
401589	2" Round Grommet and 2 Wire Pigtail w/6" Wire Lead	Wesbar Packaging

WATERPROOF/SEALED CLEARANCE/SIDE MARKER LIGHTS #31 SERIES - REPLACEMENT PARTS

Clearance/side marker light with grommet designed for quick and easy installation. Rugged ABS base that has the acrylic lens sonic welded to the base. Flush mount rubber grommet and two wire pigtail can be purchased separately or as a kit. 2 1/2" dia. x 3/4", 3 1/4" dia. w/grommet, Cutout: 2 25/32" dia.

REPLACEMENT PARTS

Part No.	Description	Packaging
40-00-002	2 Wire Pigtail w/6" Wire Lead	Bargman/Wesbar Bulk
44-00-002	2 Wire Pigtail w/6" Wire Lead	Bargman Bagged
108663	2 Wire Pigtail w/18" Wire Lead	Bargman/Wesbar Bulk
34-108663	2 Wire Pigtail w/18" Wire Lead	Bargman Bagged
221088	2 1/2" Round Open Back Heavy Duty Grommet	Bargman/Wesbar Bulk

WATERPROOF/SEALED CLEARANCE/SIDE MARKER LIGHTS 2 1/2" ROUND W/REFLEX LENS - REPLACEMENT PARTS

Clearance/side marker light with grommet designed for quick and easy installation. Rugged ABS base that has the acrylic reflex lens sonic welded to the base. Flush mount rubber grommet and two wire pigtail can be purchased separately. 2 1/2" dia. x 3/4", 3 1/4" dia. w/grommet, Cutout: 2 25/32" dia.

REPLACEMENT PARTS

Part No.	Description	Packaging
40-00-002	2 Wire Pigtail w/6" Wire Lead	Bargman/Wesbar Bulk
44-00-002	2 Wire Pigtail w/6" Wire Lead	Bargman Bagged
108663	2 Wire Pigtail w/18" Wire Lead	Bargman/Wesbar Bulk
34-108663	2 Wire Pigtail w/18" Wire Lead	Bargman Bagged
221088	2 1/2" Round Open Back Heavy Duty Grommet	Bargman/Wesbar Bulk

WATERPROOF CLEARANCE/SIDE MARKER LIGHTS 

Sonically-sealed waterproof clearance/side marker lights with break-resistant polycarbonate lens. Available in either stud-mount or ear-mount styling. Features a pre-installed 15" pigtail. Meets FMVSS/CMVSS 108 requirements for clearance/ marker lights when properly mounted.

Stud: 2 1/8" x 1 1/8" x 1 1/16"
Ear: 3 5/16" x 1 5/16" x 1"



Wet Location Lighting Products

Part No.	Description	Packaging
003273	Clearance Light Red w/White Ear-Mount Base	Bargman/Wesbar Bulk
203286	Clearance Light Red w/White Ear-Mount Base	Wesbar Packaging
003231	Clearance Light Red w/White Stud-Mount Base	Bargman/Wesbar Bulk
203234	Clearance Light Red w/White Stud-Mount Base	Wesbar Packaging
003239	Clearance Light Red w/Black Stud-Mount Base	Bargman/Wesbar Bulk
003272	Clearance Light Amber w/White Ear-Mount Base	Bargman/Wesbar Bulk
203285	Clearance Light Amber w/White Ear-Mount Base	Wesbar Packaging
003230	Clearance Light Amber w/White Stud-Mount Base	Bargman/Wesbar Bulk
203233	Clearance Light Amber w/White Stud-Mount Base	Wesbar Packaging
003238	Clearance Light Amber w/Black Stud-Mount Base	Bargman/Wesbar Bulk

CLEARANCE/SIDE MARKER LIGHTS #58 SERIES

Clearance/side marker light has a rugged ABS base and acrylic snap-on lens. The molded socket protects bulb from road shock and has two wires to eliminate surface ground. The molded grommet extends through the skin to protect the wiring.

4" x 2" x 1 1/32" w/5/8" depth



Part No.	Description	Packaging
30-58-001	Clearance Light #58 Red w/White Base	Bargman/Wesbar Bulk
34-58-001	Clearance Light #58 Red w/White Base	Bargman Bagged
30-58-002	Clearance Light #58 Amber w/White Base	Bargman/Wesbar Bulk
34-58-002	Clearance Light #58 Amber w/White Base	Bargman Bargman
54201-010	Clearance Light #58 Amber w/Black Base	Bargman/Wesbar Bulk
30-58-007	Utility Light #58 Clear w/White Base	Bargman/Wesbar Bulk

REPLACEMENT PARTS

Part No.	Description	Packaging
30-58-702	Wedge Base Socket w/#194 Bulb	Bargman/Wesbar Bulk
34-58-702	Wedge Base Socket w/#194 Bulb	Bargman Bagged
30-58-010	Lens #58 Red	Bargman/Wesbar Bulk
34-58-010	Lens #58 Red	Bargman Bagged
30-58-012	Lens #58 Amber	Bargman/Wesbar Bulk
34-58-012	Lens #58 Amber	Bargman Bagged
30-58-024	White Base	Bargman/Wesbar Bulk
30-59-054	Gasket-Foam	Bargman Bagged
34-59-054	Gasket-Foam	Bargman/Wesbar Bulk

CLEARANCE/SIDE MARKER LIGHT 2 3/4" ROUND

Round clearance/side marker light with surface mount design. Two wire construction simplifies grounding. These lights meet FMVSS-108 and CMVSS-108 requirements for P2 and PC side marker clearance functions when properly mounted.

2 3/4" Round



Part No.	Description	Packaging
30-073833	Clearance Light Red Round w/Two Wire Construction	Bargman/Wesbar Bulk
34-073833	Clearance Light Red Round w/Two Wire Construction	Bargman Bagged
30-073834	Clearance Light Amber Round w/Two Wire Construction	Bargman/Wesbar Bulk
34-073834	Clearance Light Amber Round w/Two Wire Construction	Bargman Bagged

REPLACEMENT PARTS

Part No.	Description	Packaging
108891	Bulb #193	Bargman/Wesbar Bulk

NOTE: Tail Lights, Clearance/Side Marker Lights and ID Light Bars approved for trailer accessory and towing application use. Contact your Horizon Global Representative for details.



CLEARANCE/SIDE MARKER LIGHTS #59 SERIES WITH REFLEX LENS

Clearance/side marker light has a rugged ABS base and acrylic snap-on reflex lens. The molded socket protects bulb from road shock and has two wires to eliminate surface ground. The molded grommet extends through the skin to protect the wiring.

4" x 2" x 1 1/32" w/5/8" depth

Part No.	Description	Packaging
30-59-001	Clearance Light #59 Red w/White Base	Bargman/Wesbar Bulk
31-59-001	Clearance Light #59 Red w/White Base	Bargman Clam
34-59-001	Clearance Light #59 Red w/White Base	Bargman Bagged
30-59-003	Clearance Light #59 Red w/Black Base	Bargman/Wesbar Bulk
30-59-002	Clearance Light #59 Amber w/White Base	Bargman/Wesbar Bulk
31-59-002	Clearance Light #59 Amber w/White Base	Bargman Clam
34-59-002	Clearance Light #59 Amber w/White Base	Bargman Bagged
30-59-004	Clearance Light #59 Amber w/Black Base	Bargman/Wesbar Bulk

REPLACEMENT PARTS

Part No.	Description	Packaging
30-58-702	Wedge Base Socket w/#194 Bulb	Bargman/Wesbar Bulk
34-58-702	Wedge Base Socket w/#194 Bulb	Bargman Bagged
30-59-010	Lens #59 Red	Bargman/Wesbar Bulk
31-59-010	Lens #59 Red	Bargman Clam
34-59-010	Lens #59 Red	Bargman Bagged
30-59-012	Lens #59 Amber	Bargman/Wesbar Bulk
31-59-012	Lens #59 Amber	Bargman Clam
34-59-012	Lens #59 Amber	Bargman Bagged
30-58-024	White Base	Bargman/Wesbar Bulk
30-59-054	Gasket-Foam	Bargman Bagged
34-59-054	Gasket-Foam	Bargman Bagged



CLEARANCE/SIDE MARKER LIGHTS #178 SERIES WEATHERTIGHT WITH REFLEX LENS

Clearance/side marker light has a low profile, one-piece construction with radius styling, ABS base and an acrylic reflex lens. The two wire design eliminates surface ground.

3 7/8" x 1 7/8" x 3/4" w/3/4" depth

Part No.	Description	Packaging
30-17-814	Clearance Light #178 Red w/White Base w/14" Wires	Bargman/Wesbar Bulk
34-17-808	Clearance Light #178 Red w/White Base w/14" Wires	Bargman Bagged
30-17-815	Clearance Light #178 Amber w/White Base w/14" Wires	Bargman/Wesbar Bulk
34-17-809	Clearance Light #178 Amber w/White Base w/14" Wires	Bargman Bagged

REPLACEMENT PARTS

Part No.	Description	Packaging
30-58-702	Wedge Base Socket w/#194 Bulb	Bargman/Wesbar Bulk
34-58-702	Wedge Base Socket w/#194 Bulb	Bargman Bagged
30-17-034	Gasket-Foam	Bargman/Wesbar Bulk
34-17-034	Gasket-Foam	Bargman Bagged

NOTE: Tail Lights, Clearance/Side Marker Lights and ID Light Bars approved for trailer accessory and towing application use. Contact your Horizon Global Representative for details.



CLEARANCE/SIDE MARKER LIGHTS WITH REFLEX LENS

Stud mount clearance/side marker light with reflex lens and 18" wire lead. Includes a tapered base for easy installation.

2 3/4" x 2" x 1"

Part No.	Description	Packaging
203116	Clearance Light Red	Wesbar Packaging
223117	Clearance Light Amber	Wesbar Packaging
203117	Clearance Light Amber	Bargman/Wesbar Bulk

REPLACEMENT PARTS

Part No.	Description	Packaging
108891	Bulb #193	Bargman/Wesbar Bulk
003327	Lens Red, Clearance Light	Bargman/Wesbar Bulk
90-03-327	Lens Red, Clearance Light w/Screws	Bargman Bagged
003337	Lens Red, Clearance Light w/Screws	Wesbar Packaging
003328	Lens Amber, Clearance Light	Bargman/Wesbar Bulk
90-03-328	Lens Amber, Clearance Light w/Screws	Bargman Bagged
003338	Lens Amber, Clearance Light w/Screws	Wesbar Packaging



CLEARANCE/SIDE MARKER LIGHTS WITH REFLEX LENS

Featuring reflex lens and quick connect wiring installation, these lights are available with stud-mount or ear-mount styling.

3 1/8" x 2 3/8" x 1"

Part No.	Description	Packaging
003103	Clearance Light Red w/Black Stud-Mount Base	Bargman/Wesbar Bulk
203113	Clearance Light Red w/Black Stud-Mount Base	Wesbar Packaging
003123	Clearance Light Red w/Black Ear-Mount Base	Bargman/Wesbar Bulk
203133	Clearance Light Red w/Black Ear-Mount Base	Wesbar Packaging
003101	Clearance Light Amber w/Black Stud-Mount Base	Bargman/Wesbar Bulk
203111	Clearance Light Amber w/Black Stud-Mount Base	Wesbar Packaging
003121	Clearance Light Amber w/Black Ear-Mount Base	Bargman/Wesbar Bulk
203131	Clearance Light Amber w/Black Ear-Mount Base	Wesbar Packaging

REPLACEMENT PARTS

Part No.	Description	Packaging
003327	Lens Red, Clearance Light	Bargman/Wesbar Bulk
90-03-327	Lens Red, Clearance Light w/Screws	Bargman Bagged
003337	Lens Red, Clearance Light w/Screws	Wesbar Packaging
003328	Lens Amber, Clearance Light	Bargman/Wesbar Bulk
90-03-328	Lens Amber, Clearance Light w/Screws	Bargman Bagged
003338	Lens Amber, Clearance Light w/Screws	Wesbar Packaging

NOTE: Tail Lights, Clearance/Side Marker Lights and ID Light Bars approved for trailer accessory and towing application use. Contact your Horizon Global Representative for details.

CLEARANCE/SIDE MARKER LIGHTS #99 SERIES WITH REFLEX LENS



Clearance/side marker light has an acrylic snap-on reflex lens. This unit is ready for mounting on a flat surface with quick connect wiring installation for supply and ground wires.

4 1/16" x 1 3/8" x 1"

Part No.	Description	Packaging
30-99-001	Clearance Light #99 Red	Bargman/Wesbar Bulk
31-99-001	Clearance Light #99 Red	Bargman Clam
34-99-001	Clearance Light #99 Red	Bargman Bagged
30-99-002	Clearance Light #99 Amber	Bargman/Wesbar Bulk
31-99-002	Clearance Light #99 Amber	Bargman Clam
34-99-002	Clearance Light #99 Amber	Bargman Bagged

ACCESSORY PARTS

Part No.	Description	Packaging
40-40-120	Two Light Fender Mount Bezel	Bargman/Wesbar Bulk

REPLACEMENT PARTS

Part No.	Description	Packaging
30-99-010	Lens #99 Red, Clearance Light	Bargman/Wesbar Bulk
34-99-010	Lens #99 Red, Clearance Light	Bargman Bagged
30-99-012	Lens #99 Amber, Clearance Light	Bargman/Wesbar Bulk
34-99-012	Lens #99 Amber, Clearance Light	Bargman Bagged

CLEARANCE/SIDE MARKER LIGHTS FENDER MOUNT #40 SERIES



Dual function red/amber light for use on fender mount applications. The bulb is protected by the lens on all sides. Two wire design (24" supply and ground) eliminates surface ground. Light w/black base, stainless steel mounting screws: 3.65" x 1.25" x 1.45" w/.5" depth

Light only: 2.75" x 1" x .85" w/.5" depth

Fender mount bezel only: 7.20" x 4.85" x .85"

Part No.	Description	Packaging
40-40-004	Fender Mount Clearance Light #40 Red/Amber w/Lexan® Black Base, Includes Stainless Steel Mounting Screws	Bargman/Wesbar Bulk
44-40-004	Fender Mount Clearance Light #40 Red/Amber w/Lexan® Black Base, Includes Stainless Steel Mounting Screws	Bargman Bagged
40-40-104	Fender Mount Clearance Light Red/Amber	Bargman/Wesbar Bulk

ACCESSORY PARTS

Part No.	Description	Packaging
40-40-115	Fender Mount Bezel	Bargman/Wesbar Bulk

CLEARANCE/SIDE MARKER LIGHT



Clearance/side marker light featuring quick connect wiring installation with stud mounting. Meets FMVSS/CMVSS 108 requirements for clearance/marker lights when properly mounted ("PC" rated).

2 1/4" x 2 1/4" x 1 1/4"

Part No.	Description	Packaging
003225	Clearance Light Amber	Bargman Bagged
203235	Clearance Light Amber	Wesbar Packaging

REPLACEMENT PARTS

Part No.	Description	Packaging
003330	Lens Amber, Clearance Light	Bargman Bagged
003340	Lens Amber, Clearance Light	Wesbar Packaging

NOTE: Tail Lights, Clearance/Side Marker Lights and ID Light Bars approved for trailer accessory and towing application use. Contact your Horizon Global Representative for details.



LED 6" OVAL MID-TURN LIGHT

Standard 6" grommet mount oval LED mid-turn light. Certified to SAE J914 for side turn signal. Meets FMVSS/CMVSS 108 requirements for intermediate side marker and side reflex on vehicles over 30 ft. long. Grommet and pigtail available separately.

6.48" x 2.30" x 2.71" overall height (2" depth w/pigtail, 1.35" height)



Part No.	Description	Packaging
47-06-005	6" Oval Mid-Turn Amber Light	Bargman/Wesbar Bulk

REPLACEMENT PARTS

Part No.	Description	Packaging
40-00-003	3 Wire Pigtail w/12" Wire Lead	Bargman/Wesbar Bulk
44-00-003	3 Wire Pigtail w/12" Wire Lead	Bargman Bagged
40-00-004	3 Wire 90° Pigtail w/12" Wire Lead	Bargman/Wesbar Bulk
719063	3 Wire 90° Pigtail w/12" Wire Lead	Wesbar Packaging
40-06-020	6" Oval Grommet	Bargman/Wesbar Bulk
44-06-020	6" Oval Grommet	Bargman Bagged
416088	6" Oval Grommet	Wesbar Packaging
108119	6" Oval Mounting Bracket	Bargman/Wesbar Bulk
34-108119	6" Oval Mounting Bracket	Bargman Bagged
106873	6" Oval Mounting Bracket	Wesbar Packaging
401591	6" Oval Grommet & 3 Wire 90° Pigtail	Wesbar Packaging



LED FENDER CLEARANCE LIGHTS

Compact and waterproof. Durable Polycarbonate construction with rubber gasket. European marketplace approved. P2 Rated. 11.8" wire leads.

Dimensions: 1 1/2" tall x 5 1/4" long

Part No.	Description	Packaging
54201-011	LED Fender Clearance Light Left Side	Carton
54201-013	LED Fender Clearance Light Right Side	Carton
54201-014	LED Fender Clearance Light Kit	Clam Shell

DUAL BULB CLEARANCE/SIDE MARKER LIGHTS

Lights specifically designed for heavy-duty and industrial use. Features a polycarbonate lens. Pre-wired with a 6" supply lead and are self-grounding. 4" x 2" x 1 1/8"



Part No.	Description	Packaging
003441	Clearance Light Red	Bargman/Wesbar Bulk
32-003441	Clearance Light Red	Bargman Clam
003440	Clearance Light Amber	Bargman/Wesbar Bulk
32-003440	Clearance Light Amber	Bargman Clam

REPLACEMENT PARTS

Part No.	Description	Packaging
108891	Bulb #193	Bargman/Wesbar Bulk
108844	Lens Red, Clearance Light	Bargman/Wesbar Bulk
003495	Lens Red, Clearance Light	Wesbar Packaging
108843	Lens Amber, Clearance Light	Bargman/Wesbar Bulk
003494	Lens Amber, Clearance Light	Bargman Clam

NOTE: Tail Lights, Clearance/Side Marker Lights and ID Light Bars approved for trailer accessory and towing application use. Contact your Horizon Global Representative for details.

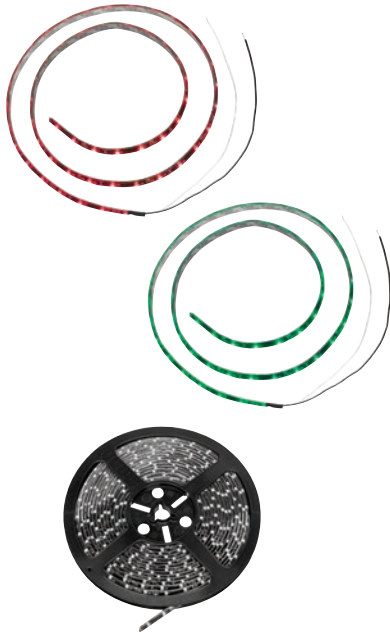

LED LIGHT STRIPS

Three foot strip, with 54 Diodes per strip. Pre-wired with a 12" supply lead and are self-grounding.

36" length

Part No.	Description	Packaging
54205-010	LED Light Strip Red - 36" w/54 Diodes Per Strip	Wesbar Packaging
54205-011	LED Light Strip Blue - 36" w/54 Diodes Per Strip	Wesbar Packaging
54205-012	LED Light Strip Amber - 36" w/54 Diodes Per Strip	Wesbar Packaging
54205-013	LED Light Strip Green - 36" w/54 Diodes Per Strip	Wesbar Packaging
54205-014	LED Light Strip Clear - 36" w/54 Diodes Per Strip	Wesbar Packaging

LED light strip on reel.

16' length

Part No.	Description	Packaging
54205-015	LED Light Strip Red - 16' Per Reel	Bargman/Wesbar Bulk
54205-016	LED Light Strip Blue - 16' Per Reel	Bargman/Wesbar Bulk
54205-017	LED Light Strip Amber - 16' Per Reel	Bargman/Wesbar Bulk
54205-018	LED Light Strip Green - 16' Per Reel	Bargman/Wesbar Bulk
54205-019	LED Light Strip Clear - 16' Per Reel	Bargman/Wesbar Bulk



LED MULTI-FUNCTIONAL STROBE LIGHTS

Has 7 optional flashing modes. Available in amber or clear. Dirt and moisture resistant. Suitable for multiple OE wiring applications.

Part No.	Description	Packaging
54205-020	LED Multi-Functional Strobe Light - Amber	Carton
54205-021	LED Multi-Functional Strobe Light - Clear	Carton



LED STROBE LIGHTS W/ 13' CORD & MAGNETIC BASE

Dirt and moisture resistant. Single mode only.

Part No.	Description	Packaging
54205-022	LED Strobe Light - Amber	Clam Shell
54205-023	LED Strobe Light - Clear	Clam Shell
54205-024	LED Strobe Light - Purple	Clam Shell



WATERPROOF LED ID LIGHT BAR

Light bar with three waterproof red lights. Stainless steel base with stud mounting. 14 1/4" x 1 3/16" x 1 1/16"

Part No.	Description	Packaging
47-99-004	Light Bar LED w/Red Lens	Bargman/Wesbar Bulk
47-99-034	Light Bar LED w/Red Lens	Bargman Bagged
401567	Light Bar LED w/Red Lens	Wesbar Packaging

REPLACEMENT PARTS

Part No.	Description	Packaging
47-99-005	Clearance Light LED #99 Red	Bargman/Wesbar Bulk
401566	Clearance Light LED #99 Red	Bargman/Wesbar Bulk



WATERPROOF LED ID LIGHT BAR

Waterproof LED low profile red light bar. This light meets FMVSS/CMVSS 108 requirements for vehicles 80" wide or wider. Prewired, single bullet supply and ring terminal ground, with 60" harness for easy installation. P2 rated.

13.54" x 1.313" x .787

Part No.	Description	Packaging
47-106858	Light Bar LED w/Red Lens	Bargman/Wesbar Bulk
42-106858	Light Bar LED w/Red Lens	Wesbar Packaging



WATERPROOF LED ID LIGHT BAR

Submersible design with black poly-carbonate base incorporates LED #37 series clearance/marker modules. Prewired (supply and ring terminal ground) for easy installation. FMVSS/CMVSS 108 P2 compliant for use to meet over 80" rear clearance marking requirements.

17" x 1.46" x 1.69"

Part No.	Description	Packaging
47-99-215	Light Bar LED w/Red Lens	Bargman/Wesbar Bulk
42-99-215	Light Bar LED w/Red Lens	Bargman Clam

REPLACEMENT PARTS

Part No.	Description	Packaging
47-37-001	Clearance Light Module LED #37 Red	Bargman/Wesbar Bulk
42-37-401	Clearance Light Module LED #37 Red	Bargman Clam
47-37-401	Clearance Light Module LED #37 Red	Bargman Bagged





LED ID LIGHT BAR WITH REFLEX LENS

This LED light bar with 3 diodes is designed for a narrow rail surface mounting. Features include built-in reflex reflectors and stainless steel grommets mounting holes. Prewired (supply and ground) for easy installation.

15.84" x 2.29" - Mounting holes on 14.49" centers

Part No.	Description	Packaging
47-54-002	Light Bar LED w/Red Lens	Bargman/Wesbar Bulk
47-54-003	Light Bar LED w/Amber Lens	Bargman/Wesbar Bulk



WATERPROOF ID LIGHT BAR

Submersible design with black poly-carbonate base incorporates incandescent #37 series clearance/marker modules. FMVSS/CMVSS 108 P2 compliant for use to meet over 80" rear clearance marking requirements.

17" x 1.46" x 1.69"

Part No.	Description	Packaging
31-99-215	Red ID Bar Incandescent, mounting holes on ends	Bargman Clam

REPLACEMENT PARTS

Part No.	Description	Packaging
40-37-001	Clearance Light Module #37 Red	Bargman/Wesbar Bulk
40-37-401	Clearance Light Module #37 Red	Bargman Bagged
203396	Clearance Light Module #37 Red	Wesbar Packaging



WATERPROOF ID LIGHT BARS

Sonically-sealed, impact-resistant polycarbonate lens and housing ensure a waterproof module. Meet or exceed all applicable state and federal regulations specified for vehicles 80" wide or wider. Three sealed polycarbonate lamps on 6" centers lead to a stainless steel base completing the best line up of waterproof light bars available today. #003305 and #003306 are pre-wired with 60" leads and can be mounted in protected areas because of their low profile.

14-1/2" x 1-1/8" x 1"

Part No.	Description	Packaging
003305	Light Bar w/Red Waterproof Modules (White Bases)	Bargman/Wesbar Bulk
203315	Light Bar w/Red Waterproof Modules (White Bases)	Wesbar Packaging
003306	Light Bar w/Red Waterproof Modules (Black Bases)	Bargman/Wesbar Bulk

NOTE: Tail Lights, Clearance/Side Marker Lights and ID Light Bars approved for trailer accessory and towing application use. Contact your Horizon Global Representative for details.





LICENSE PLATE LIGHTS #62 SERIES

License plate light with ABS body construction. The light is available in black or white. Can be purchased with or without the separate 18 gauge galvanized steel license bracket. The molded socket protects bulb from road shock and has two wires to eliminate surface ground.

4" x 1 1/2" x 2 5/8"

Part No.	Description	Packaging
30-62-003	License Light w/Bracket White	Bargman/Wesbar Bulk
34-62-003	License Light w/Bracket White	Bargman Bagged
30-62-103	License Light Less Bracket White	Bargman/Wesbar Bulk
34-62-103	License Light Less Bracket White	Bargman Bagged
30-62-002	License Light w/Bracket Black	Bargman/Wesbar Bulk
34-62-002	License Light w/Bracket Black	Bargman Bagged
30-62-102	License Light Less Bracket Black	Bargman/Wesbar Bulk
34-62-102	License Light Less Bracket Black	Bargman Bagged

REPLACEMENT PARTS

Part No.	Description	Packaging
30-62-030	License Plate Bracket	Bargman/Wesbar Bulk
34-62-030	License Plate Bracket	Bargman Bagged



LICENSE PLATE LIGHTS

Durable license plate illuminators that are dirt and moisture resistant. Housing is chrome plated steel with half shaded white lens. Mini Compact lights feature two wire construction, mounting gasket and screw. Bullet Snap-in light with self-grounding single wire construction.

2 5/8" x 1 1/4" x 1" - Mini Compact / LED Mini Compact
1" cutout - Bullet Snap-in

Part No.	Description	Packaging
30-62-000	Mini Compact Light	Bargman/Wesbar Bulk
34-62-000	Mini Compact Light	Bargman Bagged
54206-001	LED Mini Compact Light	Wesbar Packaging

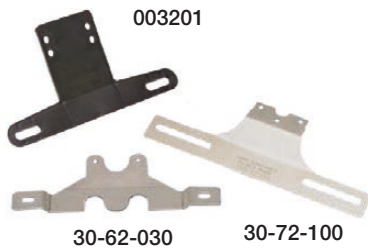

LICENSE PLATE BRACKETS

Part No.	Description	Packaging
30-62-030	License Plate Bracket 18 Gauge, Galvanized Steel	Bargman/Wesbar Bulk
34-62-030	License Plate Bracket 18 Gauge, Galvanized Steel	Bargman Bagged
30-72-100	License Plate Bracket 16 Gauge, Zinc Plated	Bargman/Wesbar Bulk
34-72-100	License Plate Bracket 16 Gauge, Zinc Plated	Bargman Bagged
003201	License Plate Bracket Plastic, Black	Bargman/Wesbar Bulk
003211	License Plate Bracket Plastic, Black	Wesbar Packaging
003213	License Plate Bracket Plastic, White	Wesbar Packaging

NOTE: Tail Lights, Clearance/Side Marker Lights and ID Light Bars approved for trailer accessory and towing application use. Contact your Horizon Global Representative for details.





BRACKET

Dark brown thermo-plastic corner bracket. .20" dia. mounting holes accept up to #10 screws.
1" X 1" X 1" - 45° angled

Part No.	Description	Packaging
60-50-001	Support Mounting Bracket	Bargman/Wesbar Bulk
64-50-001	Support Mounting Bracket	Bargman Bagged



WATERPROOF LICENSE LIGHT

Waterproof, sealed license plate light with #193 bulb for a variety of mounting applications. Pigtail available separately. Meets FMVSS/CMVSS 108 requirements.

Part No.	Description	Packaging
223210	License Plate Light and Bracket Assembly (requires 2 Wire Pigtail)	Bargman/Wesbar Bulk

ACCESSORY PARTS

Part No.	Description	Packaging
40-00-002	2 Wire Pigtail w/6" Wire Lead	Bargman/Wesbar Bulk
44-00-002	2 Wire Pigtail w/6" Wire Lead	Bargman Bagged
108663	2 Wire Pigtail w/18" Wire Lead	Bargman/Wesbar Bulk
34-108663	2 Wire Pigtail w/18" Wire Lead	Bargman Bagged

REPLACEMENT PARTS

Part No.	Description	Packaging
106310	License Light Module Clear	Bargman/Wesbar Bulk

NOTE: Tail Lights, Clearance/Side Marker Lights and ID Light Bars approved for trailer accessory and towing application use. Contact your Horizon Global Representative for details.



OBLONG/RECTANGULAR REFLECTORS

Oblong: Class “A” acrylic reflector, hermetically sealed, with two mounting holes. Optional adhesive fiber back.
4 3/8" X 1 7/8"



Part No.	Description	Packaging
70-78-010	Red w/Mounting Holes & Adhesive Back	Bargman/Wesbar Bulk
71-78-010	Red w/Mounting Holes & Adhesive Back	Bargman Clam
74-78-010	Red w/Mounting Holes & Adhesive Back	Bargman Bagged
70-78-050	Red w/Mounting Holes Only	Bargman/Wesbar Bulk
70-78-020	Amber w/Mounting Holes & Adhesive Back	Bargman/Wesbar Bulk
71-78-020	Amber w/Mounting Holes & Adhesive Back	Bargman Clam
74-78-020	Amber w/Mounting Holes & Adhesive Back	Bargman Bagged
70-78-060	Amber w/Mounting Holes Only	Bargman/Wesbar Bulk

Rectangular: Class “A” acrylic reflector, hermetically sealed, with an adhesive fiber back for instant mounting.
3 1/4" X 1 1/2"

Part No.	Description	Packaging
70-71-180	Red w/Adhesive Back	Bargman/Wesbar Bulk
74-71-180	Red w/Adhesive Back	Bargman Bagged
003358	Red w/Adhesive Back	Wesbar Packaging
70-71-181	Amber w/Adhesive Back	Bargman/Wesbar Bulk
74-71-181	Amber w/Adhesive Back	Bargman Bagged
003357	Amber w/Adhesive Back	Wesbar Packaging
323357	Amber w/Adhesive Back, w/Mounting Holes (4 3/8" X 1 1/4")	Bargman/Wesbar Bulk
323356	Red w/Adhesive Back, w/Mounting Holes (4 3/8" X 1 1/4")	Bargman/Wesbar Bulk

CONSPICUITY REFLECTORS/TAPE

Reflectors meet or exceed DOT-C and SAE J5941 for reflectivity marking on trucks and trailers. Reflectors are comparable in light return to the 2" x 12" reflective tape and hermetically sealed.

CONSPICUITY REFLECTORS - 1.1" X 12"



Part No.	Description	Packaging
74-72-040	Clear & Red w/Adhesive Back	Bargman Bagged
70-72-020	Clear w/Adhesive Back	Bargman/Wesbar Bulk
74-72-020	Clear w/Adhesive Back	Bargman Bagged
003387	Clear w/Adhesive Back	Wesbar Packaging
70-72-030	Red w/Adhesive Back	Bargman/Wesbar Bulk
74-72-030	Red w/Adhesive Back	Bargman Bagged
003388	Red w/Adhesive Back	Wesbar Packaging

ROUND REFLECTORS

Class “A” acrylic reflector, hermetically sealed. Center mounting hole or adhesive fiber back.

3 3/16" & 2 3/16"



Part No.	Description	Packaging
70-68-010	3 3/16" Red w/Center Mounting Hole	Bargman/Wesbar Bulk
74-68-010	3 3/16" Red w/Center Mounting Hole	Bargman Bagged
70-71-170	2 3/16" Red w/Center Mounting Hole	Bargman/Wesbar Bulk
74-71-170	2 3/16" Red w/Center Mounting Hole	Bargman Bagged
70-68-020	3 3/16" Amber w/Center Mounting Hole	Bargman/Wesbar Bulk
74-68-020	3 3/16" Amber w/Center Mounting Hole	Bargman Bagged
70-71-175	2 3/16" Amber w/Center Mounting Hole	Bargman/Wesbar Bulk
74-71-175	2 3/16" Amber w/Center Mounting Hole	Bargman Bagged
70-38-010	3 3/16" Red w/Adhesive Back	Bargman/Wesbar Bulk
74-38-010	3 3/16" Red w/Adhesive Back	Bargman Bagged
70-55-010	2 3/16" Red w/Adhesive Back	Bargman/Wesbar Bulk
71-55-010	2 3/16" Red w/Adhesive Back	Bargman Clam
74-55-010	2 3/16" Red w/Adhesive Back	Bargman Bagged
70-38-020	3 3/16" Amber w/Adhesive Back	Bargman/Wesbar Bulk
74-38-020	3 3/16" Amber w/Adhesive Back	Bargman Bagged
70-55-020	2 3/16" Amber w/Adhesive Back	Bargman/Wesbar Bulk
71-55-020	2 3/16" Amber w/Adhesive Back	Bargman Clam
74-55-020	2 3/16" Amber w/Adhesive Back	Bargman Bagged

NOTE: Tail Lights, Clearance/Side Marker Lights and ID Light Bars approved for trailer accessory and towing application use. Contact your Horizon Global Representative for details.



PORCH/UTILITY LIGHTS #78 SERIES

This compact design is surface mounted with either polypropylene or chrome plated ABS base and either a clear or amber snap-in lens. A remote switch is required. Two wire construction, supply and ground. CSA approved.

5 15/16" x 3 1/2" x 2"

Part No.	Description	Packaging
30-78-515	White w/Clear Lens	Bargman/Wesbar Bulk
31-78-531	White w/Clear Lens	Bargman Clam
34-78-515	White w/Clear Lens	Bargman Bagged
30-78-522	Black w/Clear Lens	Bargman/Wesbar Bulk
30-78-600	Chrome w/Clear Lens	Bargman/Wesbar Bulk
30-78-516	White w/Amber Lens	Bargman/Wesbar Bulk
31-78-532	White w/Amber Lens	Bargman Clam
34-78-516	White w/Amber Lens	Bargman Bagged
30-78-523	Black w/Amber Lens	Bargman/Wesbar Bulk

REPLACEMENT PARTS

Part No.	Description	Packaging
30-78-021	Lens #78 Clear	Bargman/Wesbar Bulk
34-78-021	Lens #78 Clear	Bargman Bagged
30-78-022	Lens #78 Amber	Bargman/Wesbar Bulk
34-78-022	Lens #78 Amber	Bargman Bagged



PORCH/UTILITY LIGHTS #78 SERIES WITH SWITCH

This compact exterior light with black rocker switch is designed for surface mounting. Polypropylene base has a lens that is snap-in and is available in either clear or amber. Two wire construction, supply and ground. CSA approved.

5 15/16" x 3 1/2" x 2"

Part No.	Description	Packaging
30-78-517	White w/Switch w/Clear Lens	Bargman/Wesbar Bulk
34-78-517	White w/Switch w/Clear Lens	Bargman Bagged
30-78-524	Black w/ Switch w/Clear lens	Bargman/Wesbar Bulk
30-78-518	White w/Switch w/Amber Lens	Bargman/Wesbar Bulk
34-78-518	White w/Switch w/Amber Lens	Bargman Bagged
30-78-525	Black w/Switch w/Amber Lens	Bargman/Wesbar Bulk

REPLACEMENT PARTS

Part No.	Description	Packaging
30-78-021	Lens #78 Clear	Bargman/Wesbar Bulk
34-78-021	Lens #78 Clear	Bargman Bagged
30-78-022	Lens #78 Amber	Bargman/Wesbar Bulk
34-78-022	Lens #78 Amber	Bargman Bagged

NOTE: Tail Lights, Clearance/Side Marker Lights and ID Light Bars approved for trailer accessory and towing application use. Contact your Horizon Global Representative for details.

SECURITY/UTILITY LIGHTS



This 12 volt surface mounted light is designed to flood light in all directions. The light adds the benefit of increased security features to any unit. Features a 7" polycarbonate lens, two wire construction and stainless steel base to resist corrosion. Designed for years of trouble-free service featuring a gasket between the lens and base, as well as a gasket for mounting.

8 3/4" dia.

Part No.	Description	Packaging
40-60-001	Security/Utility Light	Bargman/Wesbar Bulk
40-60-004	Security/Utility Light-White Painted Base	Bargman/Wesbar Bulk

REPLACEMENT PARTS

Part No.	Description	Packaging
30-90-156	Bulb #1156, Single Filament	Bargman/Wesbar Bulk

INTERIOR LIGHTS #76 SERIES



Single or double 12 volt interior light with diffused lens optics. Double light is available with single or dual switch. Two wire construction, supply and ground. Features a polypropylene base. CSA listed/ approved for ceiling mount and specific wall mounts. Contact your Horizon Global Representative for the specific wall mount applications.

7.28" x 4.33" x 1.78"

11.02" x 4.33" x 1.78"

Part No.	Description	Packaging
30-76-123	Single Light #76 w/Switch	Bargman/Wesbar Bulk
3176123	Single Light #76 w/Switch	Bargman Clam
34-76-123	Single Light #76 w/Switch	Bargman Bagged
30-76-223	Double Light #76 w/Switch	Bargman/Wesbar Bulk
34-76-223	Double Light #76 w/Switch	Bargman Bagged
30-76-243	Double Light #76 w/Dual Switch	Bargman/Wesbar Bulk
34-76-243	Double Light #76 w/Dual Switch	Bargman Bagged

REPLACEMENT PARTS

Part No.	Description	Packaging
30-90-021	Bulb #921	Bargman/Wesbar Bulk
34-90-021	Bulb #921	Bargman Bagged
30-76-028	Lens #76	Bargman/Wesbar Bulk
34-76-028	Lens #76	Bargman Bagged

INTERIOR DOME LIGHT 5" ROUND W/CHROME BASE



Chrome plated steel base with clear polycarbonate lens. Two wire construction (supply and ground) for easy installation. **Non UL/CSA, suitable for utility use in cargo trailers.**

6.43" dia. x 1.65"

Part No.	Description	Packaging
30-60-004	Interior Dome Light 5" Round w/Chrome Base	Bargman/Wesbar Bulk
30-60-005	Interior Dome Light 5" Round w/Chrome Base w/Switch	Bargman/Wesbar Bulk

REPLACEMENT PARTS

Part No.	Description	Packaging
30-90-156	Bulb #1156	Bargman/Wesbar Bulk

NOTE: Tail Lights, Clearance/Side Marker Lights and ID Light Bars approved for trailer accessory and towing application use. Contact your Horizon Global Representative for details.



30-90-156



30-90-157



30-84-057



30-90-021
34-90-021

BULB SPECIFICATION

Bulb Type	Part #	Packaging	Mean Spherical	Rated Amps Candle Power	Watts
1156	30-90-156	Bulk	32	2.10	26.880
1157	30-90-157	Bulk	32/3	2.10/0.59	26.880/8.260
193	108891	Bulk	2	0.33	4.620
2057	30-84-057	Bulk	32/2	2.10/0.48	26.880/6.720
921	30-90-021 34-90-021	Bulk Bagged	21	1.40	17.920

NOTE: Tail Lights, Clearance/Side Marker Lights and ID Light Bars approved for trailer accessory and towing application use. Contact your Horizon Global Representative for details.

LIGHTING TIPS and FAQ's

Do I have to use a light or can I use a reflector instead? Lighting and conspicuity requirements are governed by FMVSS & CMVSS 108. Their use is determined by safety and identification requirements.

Why use LED and not Incandescent? The key difference is the way both technologies operate. While both technologies are an acceptable means for vehicle lighting, LED is the stronger technology in Energy Efficiency, Light Output, Reliability, Safety and Life Expectancy.

Do LED lights have to be mounted differently than Incandescent? No, the FMVSS/CMVSS 108 mounting requirements are the same.

When retrofitting a Bargman 59 or 84/85/86 Series Incandescent light with LED can the old lenses be reused? No, Bargman® 59 & 84/85/86 Series LED module kits come with pre-assembled lenses and a simple "plug & play" replacement design.

What does stop/tail/turn mean? How many lights do I need to use to achieve it? Are they the same as "Tail Lights"? Stop/Tail/Turn is a combination rating meaning a specific light or grouping of lights in an assembly meet the requirements for this named combination. This rating can be achieved using 1 light alone as long as the light source meets the requirements for the specific application.

Why does Horizon Global offer so many different types & styles of lights for a vehicle? Horizon Global is never satisfied with the status quo and is continually striving to design lights that will meet the designated federal requirements and fit our customer's specific application needs.

When using a Multi-Function Stop/Tail/Turn Light, is a Backup Light function required and does it matter where the Backup Light is located? The requirement for and location of the Backup Light is determined by vehicle type and FMVSS/CMVSS 108 requirements.

Why are some Turn Signal Lights Red and others Amber, does it matter which color I use? Yes, the color does matter. While both colors are acceptable for turn signals, the color use is primarily driven by the "Stop" Function. When using a multi-function Stop/Turn light, the color must be Red as required by FMVSS/CMVSS 108 requirements.

What does "Over" or "Under" 80 refer to? This is a reference to a vehicles width in inches. There are differing FMVSS/CMVSS 108 requirements covering this dimensional reference point.

What are "Over 80" Combination Tail Lights?

These units meet seven or eight lighting requirements as defined by FMVSS/CMVSS 108.

What are "Under 80" Combination Tail Lights? These units meet six or seven lighting requirements as defined by FMVSS/CMVSS 108.

What is the difference between Side Marker & Clearance Lights? Side Marker Lights are mounted on the side of a vehicle and are used to define its length. Clearance Lights are mounted on the front and rear of a vehicle and are used to define its width.

What are "PC" Side Marker/Clearance Lights?

These lights meet the FMVSS/CMVSS 108 requirements for photometric certification as both Clearance and Side Marker Lights when properly mounted.

The  symbol is for Wet Location Lights. What does it mean?

Wet Location Lighting products in this catalog are either: "Waterproof/Sealed" or "Submersible" and are safe to use on marine and other trailers that will be in and around the water or UL listed as suitable for wet location use.

What are Submersible Lights? Submersible lights purposely allow water to enter the light assembly, however a cushion of air forms when water enters the light and will protect the bulbs and electrical connectivity from damage. This natural phenomenon is known as the "Bell Jar Principle". These lights are ideal for boat trailers and utility trailers that will be submersed in water.

What are Waterproof/Sealed Lights? "Waterproof" and "sealed" mean exactly the same - these lights are completely sealed and will not allow water to enter the inside of the light assembly. Many of our new LED Side/Marker and Tail Lights are completely sealed as to prevent water from damaging the circuit board and components associated with LED Technology.

Why are vehicle lights grounded? Vehicle lights are grounded in order to complete the electrical circuit. There are differing ways to ground them to meet various applications.

What is an ID Bar, and can one be used as a multi-function Stop/Tail/Turn as well? An ID Bar is an identification Bar. It consists of 3 lights and is required in order to identify the rear center location on over 80" vehicles. They May Not be used as Multi-Function Lights.

LIGHTING TERMINOLOGY AND REQUIRED EQUIPMENT

LIGHTING TERMINOLOGY

"Over 80" Combination Tail Lights

These units meet seven or eight DOT-108 lighting requirements when properly mounted. Seven function units meet tail light, stop light, rear turn signal light, rear reflex reflector, rear side marker light, rear side reflex reflector and rear clearance light. The eighth function met is license plate light. Trailers over 80 inches wide require the addition of front Clearance Lights and Rear Identification (ID) Lights. Consult Title 49 – Code of Federal Regulations-Section 571.108 (USA) or Section 108 of the Motor Vehicle Safety Regulations (Canada) for additional compliance requirements.

"Under 80" Combination Tail Lights

These units meet six or seven DOT-108 lighting requirements when properly mounted. Six function units meet tail light, stop light, rear turn signal light, rear reflex reflector, rear side marker light and rear side reflex reflector. The seventh function met is license plate light. Consult Title 49 – Code of Federal Regulations-Section 571.108 (USA) or Section 108 of the Motor Vehicle Safety Regulations (Canada) for additional compliance requirements.

"PC" Rated Clearance/Side Marker Lights

A single unit meets DOT-108 lighting requirements and has been photometrically certified at a specific installation angle to provide both clearance light and side marker light. In most cases, the light will have to be mounted on a 45° angle, Consult Title 49 – Code of Federal Regulations-Section 571.108 (USA) or Section 108 of the Motor Vehicle Safety Regulations (Canada) for additional compliance requirements to meet both functions' requirements with just one unit.

BASIC EQUIPMENT REQUIRED ON ALL TRAILERS, TRUCKS, BUSES & MPVS

Federal Motor Vehicle Safety Standards and Regulations

The tables summarize lighting equipment requirements contained in Federal/Canada Motor Vehicle Safety Standard 108.

While Horizon Global, Inc. believes this to be an accurate summary of the latest printed information, the actual standard should be consulted for design or other such purposes.

For complete compliance requirements consult Title 49 - Code of Federal Regulations-Section 571.108 (USA) or Section 108 of the Motor Vehicle Safety Regulations (Canada). State or Provincial regulations, where they may apply, have not been included.

TECHNICAL INFORMATION IS CURRENT AS OF THE PRINTING OF THIS CATALOG. CONTACT TECHNICAL SERVICE FOR PERIODIC UPDATES.

BULLDOG®
THE TRUSTED BRAND FOR
HEAVY DUTY TOWING



AGRICULTURAL

AG LED LIGHTING

Heavy-Duty AG LED Lights3
 Economy AG LED Lights.....3
 Transport AG LED Lights.....3
 Pedestal Mount AG LED Lights.....3

AG LIGHTING

Heavy-Duty AG Lights.....4
 Economy AG Lights.....4
 Transport AG Lights.....5
 Work Lights.....5

AG WIRING & ACCESSORIES

7-Way Pin Connectors.....6
 7-Way Plug Holders.....6
 Repair Harnesses.....6
 7-Way Molded Trailer Connectors.....6
 Magnet Kit.....7
 Tandem Haul Adapter.....7
 Enhanced Lighting Modules.....7
 Extension Harnesses.....7

AG JACKS

Multi-Jack.....8
 Stabilizers.....8

AG HEAVY DUTY COUPLERS

Heavy Duty Collar-Lok™ Couplers.....9-10
 Heavy Duty Cast Couplers.....11
 Heavy Duty Adjustable Couplers.....10-12
 Heavy Duty Yoke Couplers.....12

AG GOOSENECK COUPLERS

Round Gooseneck Couplers.....13-16
 Square Gooseneck Couplers.....13-14
 King Pin Gooseneck Couplers.....13-14
 BX1® Gooseneck Couplers.....15

FEATURED PRODUCTS



PEDESTAL MOUNT AG LED LIGHTS

- Left and right hand amber & red pedestal units
- Waterproof with 16 gage wire



ECONOMY AG LED LIGHT KIT

- Variety of horizontal mounting options and uses
- High-impact thermoplastic housing and recessed



AG TRANSPORT LIGHT KITS

- Featuring left and right hand dual light units with brake function
- Includes 46 ft. round wishbone, magnets and either a 7-pin or 6-pin round plug



7-WAY MOLDED CONNECTOR WITH CABLE

- 7-way plastic connector molded to heavy duty 7-way insulated cable using trailer clocking



MULTI-JACK

- Lifting, pulling, clamping, and spreading
- All-steel construction, tested at 7,000 lbs



RIGID MOUNT ADJUSTABLE COUPLER

- Anti-rattle design using 4 bolts
- 12,500 lbs



LED HEAVY-DUTY AG LIGHTS

Available in single and dual units, these lights meet all ASABE S279.15 lighting requirements including 4cp to side on amber lens. Dual lights designed for right hand and left hand horizontal mounting. Rugged external housing and lens design. Same mounting foot print hardware and electrical connections as incandescent equivalent. Brake functions wired with SQ-4 plug.

6" x 5 1/2" x 3", 10 1/2" x 5 1/2" x 3"



NOTE: As of June 22, 2017 all agricultural equipment operated on public roads needs to conform to ASABE 279.14 per government regulation found in 49 CFR Part 562. Please review these documents to make sure your equipment is up to date.

Part No.	Description
54209-009	Single LED AG Light w/2 Wire Leads - Lens: Rear-Red, Front-Blank
54209-011	Single LED AG Light w/2 Wire Leads - Lens: Rear-Amber, Front-Amber
54209-010	Single LED AG Light w/2-Way Plug - Lens: Rear-Red, Front-Blank
54209-012	Single LED AG Light w/2-Way Plug - Lens: Rear-Amber, Front-Amber
54209-013	Single LED AG Light w/3 Wire Leads - Lens: Rear-Red, Front-Blank
54209-015	Single LED AG Light w/3 Wire Leads - Lens: Rear-Amber, Front-Amber
54209-014	Single LED AG Light w/3-Way Plug - Lens: Rear-Red, Front-Blank
54209-016	Single LED AG Light w/3-Way Plug - Lens: Rear-Amber, Front-Amber
54209-019	Dual RH LED AG Light w/3 Wire Leads - Lens: Rear-Red/Amber, Front-Amber/Blank
54209-005	Dual LH LED AG Light w/3 Wire Leads - Lens: Rear-Amber/Red, Front-Blank/Amber
54209-020	Dual RH LED AG Light w/3-Way Plug - Lens: Rear-Red/Amber, Front-Amber/Blank
54209-006	Dual LH LED AG Light w/3-Way Plug - Lens: Rear-Amber/Red, Front-Blank/Amber
54209-021	Dual RH LED AG Light w/4 Wire Leads - Lens: Rear-Red/Amber, Front-Amber/Blank
54209-007	Dual LH LED AG Light w/4 Wire Leads - Lens: Rear-Amber/Red, Front-Blank/Amber
54209-022	Dual RH LED AG Light w/4-Way Square Plug - Lens: Rear-Red/Amber, Front-Amber/Blank
54209-008	Dual LH LED AG Light w/4-Way Square Plug - Lens: Rear-Amber/Red, Front-Blank/Amber

Note: Reference AG Lighting - Technical for mounting applications.

LED ECONOMY AG LIGHT KIT

Featuring left hand and right hand dual light units, this kit include a 35 ft. wishbone wire harness, 7-pin AG plug and tri-plugs. For protection in critical areas, 5' of convoluted tubing is included.



Part No.	Description
54003-040	Economy AG LED Light Kit

REPLACEMENT PARTS

54209-006	Dual LH LED AG Light w/3-Way Plug - Lens: Rear-Amber/Red, Front-Amber/Blank
54209-020	Dual RH LED AG Light w/3-Way Plug - Lens: Rear-Red/Amber, Front-Amber/Blank

US Patent D347,903/5,335,155

NOTE: Reference AG Lighting - Technical for mounting applications.

LED AG TRANSPORT LIGHT KITS

Featuring left and right hand dual light units with brake function, these kits include a 46 ft. round wishbone cable, four 90 lb. magnets and a 7-pin round plug.



Part No.	Description
54003-041	Deluxe AG LED Transport Kit w/Brake Light Function, 7-Pin

REPLACEMENT PARTS

54209-008	Dual LH LED AG Light w/4-Way Square Plug - Lens: Rear-Amber/Red, Front-Amber/Blank
54209-022	Dual RH LED AG Light w/4-Way Square Plug - Lens: Rear-Red/Amber, Front-Amber/Blank
002590	Magnet Kit, 90 lb. Pull

US Patent D347,903/5,335,155

NOTE: Reference AG Lighting - Technical for mounting applications.

NOTE: Custom AG lighting and wiring kits are available. Contact your Horizon Global Representative for requirements and minimum annual quantities.



PEDESTAL MOUNT AG LED LIGHTS



Meets ASABE S279, FMVSS-108DOT, & EC requirements. AMECA certified. Custom connector options available. Amber lamps meet 4cp sidelight requirements in horizontal and vertical mounting options. Lamps are Waterproof with 16 wire gage. Dia. 4-3/4" x Height 5" x Cable Length 12"

NOTE: As of June 22, 2017 all agricultural equipment operated on public roads needs to conform to ASABE 279.14 per government regulation found in 49 CFR Part 562. Please review these documents to make sure your equipment is up to date.

Part No.	Description
54209-031	Pedestal Mount Single AG LED Light w/Amber/Amber
54209-032	Pedestal Mount Single AG LED Light w/Red
54209-047	Pedestal Mount AG LED Light w/Amber
54209-048	Pedestal Mount Single AG LED Light w/Red
54003-137	Economy AG LED Light Kit, 7-Pin, w/ Pedestal Mount Amber/Amber/Red, Tri-Mold w/35' Wishbone Harness
54003-138	Deluxe AG LED Transport Kit w/Brake Light Function, 7-Pin, Amber/Amber/Red, w/46' Wishbone Harness

HEAVY-DUTY AG LIGHTS

Available in single and dual units, these lights meet all ASABE S279.13 lighting requirements including 4cp to side on amber lens. Dual lights designed for right hand-horizontal/vertical mounting or left hand-horizontal/vertical mounting. Rugged external housing and lens design with vibration dampening bulb holder. Brake functions wired with SQ-4 plug.

6" x 5 1/2" x 3", 10 1/2" x 5 1/2" x 3"



Part No.	Description
8260501	Single AG Light 2 Wire w/3-Way Plug - Lens: Rear-Red, Front-Blank
8260601	Single AG Light 2 Wire w/3-Way Plug - Lens: Rear-Amber, Front-Amber
8261001	Single AG Light 3 Wire w/3-Way Plug - Lens: Rear-Red, Front-Blank
8260502	Single AG Light 2 Wire w/2-Way Weatherpack Plug - Lens: Rear-Red, Front-Blank
8260602	Single AG Light 2 Wire w/2-Way Weatherpack Plug - Lens: Rear-Amber, Front-Amber
8261002	Single AG Light 3 Wire w/3-Way Weatherpack Plug - Lens: Rear-Red, Front-Blank
8260001	Dual LH AG Light 3 Wire w/3-Way Plug - Lens: Rear-Amber/Red, Front-Blank/Amber
8260101	Dual RH AG Light 3 Wire w/3-Way Plug - Lens: Rear-Red/Amber, Front-Amber/Blank
8261501	Dual LH AG Light 4 Wire w/4-Way Square Plug-Lens: Rear-Amber/Red, Front-Blank/Amber
8261601	Dual RH AG Light 4 Wire w/4-Way Square Plug-Lens: Rear-Red/Amber, Front-Amber/Blank
8261605	Dual RH AG Light 4 Wire w/4-Way Weatherpack Plug-Lens: Rear-Red/Amber, Front-Amber/Blank

REPLACEMENT PARTS

30-90-157	Bulb #1157, Double Filament
802650	Lens Amber, AG Lamp
802651	Lens Red, AG Lamp
802652	Insert Black, AG Lamp

Note: Reference AG Lighting - Technical for mounting applications.

Note: Custom AG lighting and wiring kits are available. Contact your Horizon Global Representative for requirements and minimum annual quantities.

ECONOMY AG LIGHT KIT

Featuring left hand and right hand dual light units, this kit include a 35 ft. wishbone wire harness, 7-pin AG plug and tri-plugs. For protection in critical areas, 5' of convoluted tubing is included.



Part No.	Description
002670	Economy AG Light Kit

REPLACEMENT PARTS

8260001	Dual AG Light w/Amber/Red
8260101	Dual AG Light w/Red/Amber

US Patent D347,903/5,335,155

NOTE: Reference AG Lighting - Technical for mounting applications.

NOTE: Tail Lights, Clearance/Side Marker Lights and ID Light Bars approved for trailer accessory and towing application use. Contact your Horizon Global Representative for details.



AG TRANSPORT LIGHT KITS

Featuring left and right hand dual light units with brake function, these kits include a 46 ft. round wishbone cable, four 90 lb. magnets and either a 7-pin or 6-pin round plug.

Part No.	Description
002675	Deluxe AG Transport Kit w/Brake Light Function, 6-Pin
002676	Deluxe AG Transport Kit w/Brake Light Function, 7-Pin

REPLACEMENT PARTS

8261501	Dual AG Light w/Amber/Red w/Brake Light Function
8261601	Dual AG Light w/Red/Amber w/Brake Light Function
002590	Magnet Kit, 90 lb. Pull

US Patent D347,903/5,335,155
 Note: Reference AG Lighting - Technical for mounting applications.

NOTE: As of June 22, 2017 all agricultural equipment operated on public roads needs to conform to ASABE 279.14 per government regulation found in 49 CFR Part 562. Please review these documents to make sure your equipment is up to date.



LED WORK LIGHTS

LED work lights perfect for exterior use in AG, horse, livestock, RV, industrial and racing applications. Environmentally sealed design with aluminum housing and stainless steel mounting stud. High power, true white 9-36V, 10W light emission. Rectangular version with 10 LED diodes, circular model has 8 LED diodes.

Circular: 4.5" dia. x 1.5" depth
 Rectangular: 4" x 4" x 1.5" depth

Part No.	Description	Packaging
54209-001	Circular LED Light, 8 Diodes	Bargman/Wesbar Bulk
54209-002	Rectangular LED Light, 10 Diodes	Bargman/Wesbar Bulk
54209-025	Rectangular LED Light, 10 Diodes w/Molded 2-Way Plug	Bargman/Wesbar Bulk



LED WORK LIGHTS WITH COILED CORD & MAGNETIC BASE

LED work lights perfect for exterior use in AG, horse, livestock, RV, industrial and racing applications. Environmentally sealed design with 19' extended coiled cord. Magnetic base, with protective film, secures in high vibration conditions in a vertical or horizontal position. Power adapter for 12V outlet with separate on/off switch. High power, true white 9-36V, 10W light emission. Rectangular version with 10 LED diodes, circular model has 8 LED diodes.

Circular: 4.5" dia. x 1.875" depth
 Rectangular: 4" x 4" x 1.75" depth

Part No.	Description	Packaging
54209-017	Circular LED Light, w/Cord, Magnetic Base, 8 Diodes	Wesbar Packaging
54209-018	Rectangular LED Light, w/Cord, Magnetic Base, 10 Diodes	Wesbar Packaging

7-WAY ROUND PIN AG CONNECTORS

A discrete round pin 7-way vehicle and implement connector for AG OEM and aftermarket use. Vehicle side connector includes a mountable storage box. Implement side connector includes a metal spring cable relief.



Part No.	Description	Packaging
787305	7-Way Round Pin AG Vehicle Connector	Bulk
787303	7-Way Round Pin AG Vehicle Connector	Clam - Wesbar
787304	7-Way Round Pin AG Trailer Connector	Bulk
787302	7-Way Round Pin AG Trailer Connector	Clam - Wesbar

7-WAY AG PLUG HOLDER



Part No.	Description	Packaging
105728	AG 7-Way Plug Holder	Clam - Wesbar



AG REPAIR HARNESSSES

Part No.	Description	Packaging
54003-017	AG Repair Harness, 4 Wire w/4-Way Square Connector	Bulk
54003-018	AG Repair Harness, 4 Wire w/4-Way Square Connector	Bulk
54003-020	AG Repair Harness, 4 Wire w/4-Way Weatherpack Connector	Bulk

7-WAY MOLDED TRAILER CONNECTORS WITH CABLE - TRAILER CLOCKING

7-way plastic connector molded to heavy duty 7-way insulated cable using trailer clocking*. Provides 7-way connector contact color coding more conducive to horse and livestock trailers verses RV trailers. Made with self-cleaning contacts and molded to encapsulate terminals and wires to form one weather resistant, non-corrosive assembly. Permits the trailer to have the clean appearance and environmental advantages of a sealed, molded 7-way cord. Primary wire gauges within the insulated cable are: Black and White-10 gauge, Blue-12 gauge, Brown-Red-Green-Yellow-14 gauge.



Part No.	Description	Packaging
50-67-614	7-Way Molded Trailer Cord w/4' Cable	Bulk
50-67-616	7-Way Molded Trailer Cord w/6' Cable	Bulk
50-67-618	7-Way Molded Trailer Cord w/8' Cable	Bulk
50-67-620	7-Way Molded Trailer Cord w/10' Cable	Bulk

*NOTE: Reference Wiring Diagrams for pin locations.

NOTE: Various length and combinations available. Crimped junction box terminals can be added. Contact your Horizon Global Representative for details.



MAGNET KIT

Use of this magnet kit allows for temporary installation of single or dual lights. Set of four with hardware.

Part No.	Description	Packaging
002590	Magnet Kit, 90 lb. Pull	Bulk



TANDEM HAUL ADAPTER

The Tandem Haul Adapter allows implements to be towed in tandem, providing versatility and economy.

Part No.	Description	Packaging
002500	Tandem Haul Adapter	Bulk
002625	Tandem Haul Kit	Bulk



AG LIGHT ENHANCED LIGHTING MODULES

Install to meet the enhanced lighting standard and have a dramatic safety feature to better signal turns by tractors and implements. Contact your Horizon Global Representative for additional information.

Part No.	Description	Packaging
108060	Module w/Wire Leads	Bulk
108318	Module w/Molded Plugs	Bulk
108319†	Module w/Weatherproof Plugs	Bulk
109992	Module w/Brake Light Signal Function w/Wire Leads	Bulk

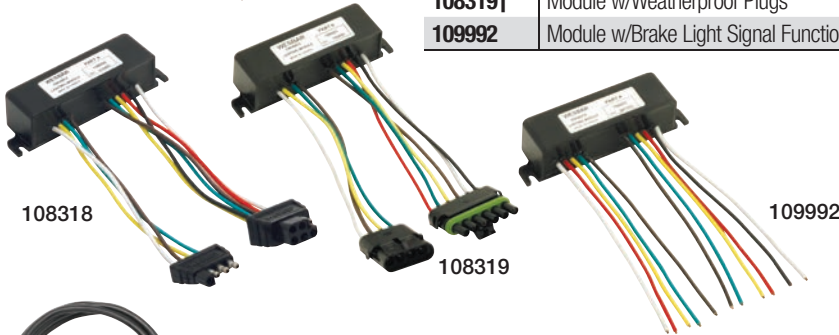

AG EXTENSION HARNESES

Install on towable field implements to bring power from the tractor to AG Lights. Full length ground assures reliable and continuous operation. Custom configurations and lengths available.

Part No.	Description	Packaging
002510	10' Heavy-Duty Wishbone Harness	Bulk
002408	5' Economy Extension Harness	Bulk
002410	10' Economy Extension Harness	Bulk
002415	15' Straight Section Harness w/7-Pin AG Plug and Flat 4-Way	Bulk
002425	25' Straight Section Harness w/7-Pin AG Plug and Flat 4-Way	Bulk
002430	30' Straight Section Harness w/7-Pin AG Plug and Flat 4-Way	Bulk
002435	35' Extension Harness	Bulk
002504	10' Economy Rear Wishbone Harness	Bulk
002505	15' Economy Rear Wishbone Harness	Bulk
002515	15' Heavy-Duty Rear Wishbone Harness	Bulk
54003-145	Ag Heavy-Duty Wishbone Harness, 1' Long for #108318	Bulk
54003-146	Ag Extension Harness, 11'6" Long Left Side, for use with #108318	Bulk
54003-147	Ag Extension Harness, 10'3" Long Right Side, for use with #108318	Bulk



† = Available while supplies last.

MULTI-JACK

A versatile tool for lifting, pulling, clamping, and spreading, the BULLDOG 48" Multi-Jack is always handy to have along on 4x4s and other off-road vehicles. You'll really appreciate its power when it makes backbreaking jobs like tearing out stumps and pulling up posts a breeze.

- ALL-STEEL CONSTRUCTION - Provides reliable strength
- RUGGED RATCHET DESIGN - Holds up to time and heavy use
- 36" STEEL HANDLE - Multiplies effort while keeping the operator clear
- LARGE 10" X 10" BASE - Increases ground contact surface area
- 35" OF TRAVEL - Lets you lift loads from 5" to 40" with ease
- SIMPLE DESIGN - Packs power into 30 lbs. of multipurpose equipment

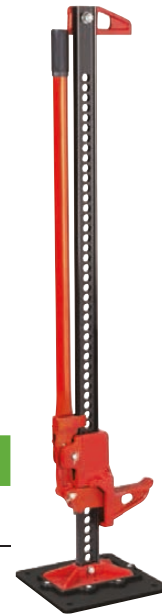

MULTI-JACK

Part No.	Capacity	Travel	Extended	Description	Pkg.	Unit Wt. Lbs.
148700	Tested to 7,000 lbs. (4,660 lbs. maximum rated load at 48")	35"	48"	Multipurpose Jack	Ind. Pack	30.0

STABILIZERS

Square tube stabilizers are fabricated from high strength, structural steel tubing, and are yellow zinc-plated for excellent corrosion-resistance. Common applications include cargo trailers, industrial implements, and equipment outriggers.



STABILIZERS

Part No.	Static Capacity (lbs.)	Adjustment Range (A)	Overall Length Dimension	Description	Pkg.
STABILIZER - KIT					
SJL8 0300	2,000	8" - 27"	20" drop leg, 8" outer	Assembly drop leg and 1-1/2" outer tube (includes pin)	Bulk
STABILIZER - TUBE AND DROP LEGS					
SJ1 0300	3,000	N/A	13"	2" square outer tube, oil finish (pin not included)	Bulk
SJ2 0324	3,000	25" - 37"	28.75"	Square drop leg with adjustment holes (pin not included)	Bulk
SJ4 0324	3,000	18" - 28"	20"	Square drop leg with adjustment holes (pin not included)	Bulk
STABILIZER - DROP LEG					
SJW 0324	3,000	Up to 24"	30.5"	Square drop leg with adjustment holes, foot at 30 degree angle to tube. NOTE: Will not work with SJ1 0300 tube.	Bulk



028499



HEAVY DUTY COUPLERS

Designed for utility, horse/livestock, cargo, and construction trailer applications, BULLDOG Collar-Lok™ are the strongest in the industry. The BULLDOG design features the only automatic and continuously tight ball fit in the industry. A variety of coupler styles, tongue mounts, and latches allow configurations to match virtually any trailer. Adjustable couplers assure level operation for trailers when pulled by a variety of different vehicles.

- Easiest to use
- Strong in both static and dynamic loading conditions
- Hinged ball socket for easy hook up
- Clear, visual indication of proper closure
- In compliance with SAE standard J684





028655



028630





COLLAR-LOK™ COUPLERS - TONGUE MOUNTS

	No. 2 Tongue Mount 2-1/4" outside diameter x 1-3/4" inside diameter steel tubing.
	No. 4 Tongue Mount High-strength steel for 3" square or rectangular trailer tongue.
	No. 5 Tongue Mount High-strength steel for 3-1/2" OD round trailer tongue.
	No. 6 Channel Mount Fits inside 3" wide channel.
	No. 8 Tongue Mount High-strength steel for 50-degree trailer tongue (tapped mounting holes optional for A-frame style jacks).

COLLAR-LOK™ COUPLERS - "B" STYLE COUPLERS

	2B Style 5,000 lbs. gross trailer weight for 2" ball.
	3B Style 7,000 lbs. gross trailer weight for 2" ball.
	4B Style 12,500 lbs. gross trailer weight for 2-5/16" ball.
	5B Style 15,000 lbs. gross trailer weight for 2-5/16" ball.

COLLAR-LOK™ COUPLERS - LATCHES

	L - Low Profile (No. 8 Tongue Mount only)
	H - High Profile
	M - Pin Only

028657





HEAVY DUTY COUPLERS - COLLAR-LOK™ COUPLERS

Part No.	Model No.	Gross Trailer Weight	Overall Length	Latches	Ball Size	SAE Class	Coupler Style	Description	Unit Weight Lbs.
NO. 2 ROUND TUBULAR TONGUE MOUNT									
028381	2B2H	5,000	10-3/4"	High Profile	2"	III	2B Style	2-1/4" OD x 1-3/4" ID, steel tubing	8.0
028242	2B2M	5,000	10-3/4"	Pin Style	2"	III	2B Style	2-1/4" OD x 1-3/4" ID, steel tubing	8.0
028461	4B2H	12,500	12-3/4"	High Profile	2-5/16"	N/A	4B Style	2-1/4" OD x 1-3/4" ID, steel tubing	8.0
028442	4B2M	12,500	12-3/4"	Pin Style	2-5/16"	N/A	4B Style	2-1/4" OD x 1-3/4" ID, steel tubing	8.0
NO. 4 3" SQUARE/RECTANGULAR TONGUE MOUNT									
028382 ◊	2B4H	5,000	16-1/4"	High Profile	2"	III	2B Style	High-strength steel for 3" square or rectangular trailer tongue	10.5
028244	2B4M	5,000	16-1/4"	Pin Style	2"	III	2B Style	High-strength steel for 3" square or rectangular trailer tongue	10.5
028387 ◊	3B4H	7,000	16-1/4"	High Profile	2"	IV	3B Style	High-strength steel for 3" square or rectangular trailer tongue	11.5
028243	3B4M	7,000	16-1/4"	Pin Style	2"	IV	3B Style	High-strength steel for 3" square or rectangular trailer tongue	11.5
028462 ◊	4B4H	12,500	16-1/2"	High Profile	2-5/16"	N/A	4B Style	High-strength steel for 3" square or rectangular trailer tongue	12.0
028444	4B4M	12,500	16-1/2"	Pin Style	2-5/16"	N/A	4B Style	High-strength steel for 3" square or rectangular trailer tongue	12.0
NO. 5 3" ROUND STRAIGHT TONGUE MOUNT									
028383	2B5H	5,000	16-1/4"	High Profile	2"	III	2B Style	High-strength steel for 3-1/2" OD round trailer tongue	10.5
NO. 6 ADJUSTABLE CHANNEL MOUNT									
028390 ◊	3B6M	7,000	9.5"	Pin Style	2"	IV	3B Style	Fits inside 3" wide channel	10.0
028584	3B6M	7,000	9.5"	Pin Style	2"	IV	3B Style	Rigid mount, 4-bolt design, fits inside 3" wide channel	10.0
028630 ◊	4B6M	12,500	10"	Pin Style	2-5/16"	N/A	4B Style	Fits inside 3" wide channel	11.5
028585	4B6M	12,500	10"	Pin Style	2-5/16"	N/A	4B Style	Rigid mount, 4-bolt design, fits inside 3" wide channel	11.5
028657	5B6M	15,000	10"	Pin Style	2-5/16"	N/A	5B Style	Fits inside 3" wide channel	11.7
NO. 8 A-FRAME TONGUE MOUNT									
028384	2B8H	5,000	16"	High Profile	2"	III	2B Style	High-strength steel for 50° trailer tongue	12.0
028288 ◊	2B8L	5,000	16"	Low Profile	2"	III	2B Style	High-strength steel for 50° trailer tongue	12.0
028386	3B8H	7,000	16"	High Profile	2"	IV	3B Style	High-strength steel for 50° trailer tongue	13.0
028287 ◊	3B8L	7,000	16"	Low Profile	2"	IV	3B Style	High-strength steel for 50° trailer tongue	13.0
028463	4B8H	12,500	16-1/2"	High Profile	2-5/16"	N/A	4B Style	High-strength steel for 50° trailer tongue	14.0
028499 ◊	4B8L	12,500	16-1/2"	Low Profile	2-5/16"	N/A	4B Style	High-strength steel for 50° trailer tongue	14.0
028656	5B8H	15,000	16-1/2"	High Profile	2-5/16"	N/A	5B Style	Black primed finish	16.0
028655	5B8L	15,000	16-1/2"	Low Profile	2-5/16"	N/A	5B Style	Black primed finish	16.0
REPLACEMENT PART									
024200	N/A	N/A	N/A	High Profile	N/A	N/A	N/A	Collar-Lok™ Coupler kit, includes high profile latch handle, latch wire, latch pin, push nut, and cotter pin	N/A
500354	N/A	N/A	N/A	N/A	N/A	N/A	N/A	Coupler Cap Spring	N/A

NOTE: Other custom-made designs are available upon request. ◊ DENOTES MOST POPULAR

⚠ WARNING

Failure to close coupler securely before towing or failure to use with specified ball size may result in serious injury or death.



44150W

CAST COUPLERS

Designed for utility, horse/livestock, cargo, and construction trailer applications, BULLDOG Couplers are the strongest in the industry. The patented cast head "Wedge-Latch" coupler design is offered in heavy-duty, A-frame, and convenient adjustable height models. Adjustable couplers assure level operation for trailers when pulled by a variety of different vehicles. The replaceable latching hardware allows for longer service life.

- Quick and easy to engage
- Strong and secure on the road
- Patented Wedge-Latch® ball clamp design
- Quick to hook up and disconnect
- In compliance with SAE standard J684



Wedge-Latch® A-Frame Mount, Patent Pending, Cast A-frame couplers with patented replaceable hardware for longer service life



Wedge-Latch® Flat Plate Mount



Wedge-Latch® Adjustable Height Coupler
US Patent 6,505,849



Adjustable Height Bracket

HEAVY DUTY COUPLERS - CAST COUPLERS

Part No.	Gross Trailer Weight	Overall Length	Latches	Ball Size	SAE Class	Description	
WEDGE-LATCH® CAST HEAD COUPLERS							
43805W0317	8,000	18"	Wedge-Latch	2"	IV	Round jack mount, 50° A-frame	14.3
44125W0317	12,500	18"	Wedge-Latch	2-5/16"	IV	Round jack mount, 50° A-frame	18.6
44150W0317	15,000	18"	Wedge-Latch	2-5/16"	IV	Round jack mount, 50° A-frame	18.6
44150WQ317	15,000	18"	Wedge-Latch	2-5/16"	IV	Square jack mount, 50° A-frame	18.6
44150WH301	15,000	18"	Wedge-Latch	2-5/16"	IV	Round jack mount, 50° A-frame, for bolt-on applications	18.6
WEDGE-LATCH® FLAT MOUNT CAST HEAD COUPLERS							
4420000317	20,000	N/A	Wedge-Latch	2-5/16"	N/A	Cast head, 4-1/2" mount pattern, grey primer coat	14.0
4425000317	25,000	N/A	Wedge-Latch	2-5/16"	N/A	Cast head, 4-1/2" mount pattern, grey primer coat	15.0
ACCESSORY PART - WEDGE-LATCH® FLAT MOUNT CAST HEAD COUPLER							
PL4 0201		N/A	N/A	N/A	N/A	Pin/Lanyard 5/16" with 4 Link Chain & Tab	0.75
WEDGE-LATCH® ADJUSTABLE HEIGHT CAST HEAD COUPLERS							
A200C 0317	8,000	8-1/2"	Wedge-Latch	2"	IV	Cast head includes mounting hardware, adjustable height	9.5
A2003C0317	8,000	9-1/4"	Wedge-Latch	2"	IV	Cast head includes bolts and 3-position channel, adjustable height	13.7
A2005C0317	8,000	9-1/4"	Wedge-Latch	2"	IV	Cast head includes bolts and 5-position channel, adjustable height	15.8
A256C 0317	14,000	9-1/4"	Wedge-Latch	2-5/16"	IV	Cast head includes mounting hardware, adjustable height	10.1
A2563C0317	14,000	9-1/2"	Wedge-Latch	2-5/16"	IV	Cast head includes bolts and 3-position channel, adjustable height	14.3
A2565C0317	14,000	9-1/2"	Wedge-Latch	2-5/16"	IV	Cast head includes bolts and 5-position channel, adjustable height	16.4
ACCESSORY / REPLACEMENT PARTS - ADJUSTABLE HEIGHT CHANNEL BRACKET							
AC300 0300		8" Height	N/A	N/A	N/A	4-hole, 3-position bracket, with 4" of vertical adjustment, adjustable height	4.18
AC500 0300		11-3/4" Height	N/A	N/A	N/A	6-hole, 5-position bracket, with 8" of vertical adjustment, adjustable height	6.32
66 0801		N/A	N/A	2"	N/A	2" Ball size Wedge-Latch® repair kit. Includes latch lever, ball clamp, and replacement hardware	1.0
67 0801		N/A	N/A	2-5/16"	N/A	2-5/16" Ball size Wedge-Latch® repair kit. Includes latch lever, ball clamp, and replacement hardware	1.0

NOTE: Other custom-made designs are available upon request.



A200S 0303

ADJUSTABLE HEIGHT HEAVY DUTY COUPLERS

Designed for utility, horse/livestock, cargo and construction trailer applications, BULLDOG Couplers are the strongest in the industry. The patented cast head "Wedge-Latch" coupler design is offered in heavy-duty, A-frame, and convenient adjustable height models. Adjustable couplers assure level operation for trailers when pulled by a variety of different vehicles. The replaceable latching hardware allows for longer service life.

- Quick and easy to engage
- Strong and secure on the road
- Patented Wedge-Latch ball clamp design
- Quick to hook up and disconnect
- In compliance with SAE standard J684

ADJUSTABLE HEIGHT COUPLERS

Part No.	Gross Trailer Weight	Overall Length	Ball Size	Description	Unit Wt. Lbs.
A200S 0303	8,000	9.00"	2"	Black E-Coat Finish Mounting Hardware Included, Mounting Bracket Sold Separately	7.90
A256S 0303	14,000	9.50"	2-5/16"	Black E-Coat Finish, Mounting Hardware Included, Mounting Bracket Sold Separately	8.00

MOUNTING BRACKETS

Part No.	Overall Height	Description	Unit Wt. Lbs.
AC300 0300	8.00"	3 Position, Raw Finish, Mounting Hardware Sold Separately	4.20
AC500 0300	11.75"	5 Position, Raw Finish, Mounting Hardware Sold Separately	6.40
024202	n/a	Mounting Hardware, Individually Bagged	1.00



E338050303



E438050303

YOKE COUPLER

Part No.	Gross Trailer Weight	Ball Size	Description	Unit Wt. Lbs.
E338050303	5,000	2"	Class III Coupler, Round Jack Mount 50° A-Frame, Black E-Coat Finish, Weld-on	7.80
E438050303	8,000	2"	Class IV Coupler, Round Jack Mount 50° A-Frame, Black E-Coat Finish Weld-on	7.80

⚠ WARNING

Failure to close coupler securely before towing or failure to use with specified ball size may result in serious injury or death.



0289500300



0287600300

ROUND GOOSENECK COUPLERS

BULLDOG gooseneck couplers are quick and easy to engage and strong and secure on the road. Our unique, patented, extruded locking plate design and high-strength steel components make BULLDOG gooseneck couplers 65% stronger than similar products.

- Easy-grip locking handle is accessible from any position, even with a glove on
- Self-centering locking plate lets you miss the ball by more than an inch
- Tight ball fit reduces jarring when changing speeds or on rough roads
- Heavy-duty construction provides unmatched strength
- User-friendly design is simple to use
- Quick to hook up and disconnect
- Easy vertical adjustment



GN24



0289500300



028900



0289600300

SQUARE GOOSENECK COUPLERS

You won't find a coupler that's faster or easier to use than the BULLDOG square gooseneck from Horizon Global. Its user-friendly design makes hookup and release swift and secure.

- Easy-grip locking handle is accessible from any position
- Self-centering locking plate lets you miss the ball by more than an inch
- Tight ball fit reduces jarring when changing speeds or on rough roads
- Heavy-duty high-strength fabricated steel components are as strong as heavy cast iron but lighter and less brittle
- User-friendly design enables quick, easy hookup and release
- Locking handle cover protects working parts
- Cam locking pin affords easy vertical adjustment
- Pinch bolt design



0289580300



0289590300

KING PIN GOOSENECK COUPLERS

- Allows gooseneck trailer to be towed with vehicles equipped with a fifth wheel hitch
- Feature dual set bolts
- Round model features exclusive load bearing pin
- Square model features exclusive load bearing pinch bolt
- Available with or without outer tube

NOTE: All BULLDOG® Gooseneck Couplers are in compliance with the SAE standard J2638 .

WARNING

Failure to close coupler securely before towing or failure to use with specified ball size may result in serious injury or death.

ROUND GOOSENECK COUPLERS

Part No.	Capacity	Overall Height		Adjustment	Ball Size	Description	Unit Wt. Lbs.
		Retracted	Extended				
ROUND GOOSENECK FIXED COUPLER							
0287690300	20,000	33.00"	N/A		2-5/16"	Fixed base coupler.	38.0
ROUND GOOSENECK ADJUSTABLE COUPLER							
0287600300	20,000	29.20"	8.0"		2-5/16"	Adjustable gooseneck coupler.	46.0
0287610300	20,000	27.20"	8.0"		2-5/16"	Adjustable gooseneck coupler. No outer tube.	30.0
0287620300	20,000	29.30"	8.0"		2-5/16"	Adjustable gooseneck coupler with cap.	48.0
0287650300	20,000	28.60"	8.0"		2-5/16"	Adjustable gooseneck coupler. No outer tube. GN24 coupler head.	25.5
0287760300	20,000	29.50"	8.0"		2-5/16"	Adjustable gooseneck coupler. GN24 coupler head.	47.3
0289340317	25,000	28.10"	8.0"		2-5/16"	4.5" diameter outer tube, 4" diameter inner tube, with GN24 coupler head, 3/4" load bearing pin.	45.4
0289250300	25,000	29.30"	8.0"		2-5/16"	4.5" diameter outer tube, 4" diameter inner tube, with cast locking plates. 3/4" load bearing pin.	50.0
0289500300	30,000	29.30"	8.0"		2-5/16"	4.5" diameter outer tube, 4" diameter inner tube, with cast locking plates. 3/4" load bearing pin.	52.0
GOOSENECK COUPLER HEAD							
GN24 0200	24,000	N/A	N/A		2-5/16"	Cast steel gooseneck coupler designed for easy welding to 3" or 4" diameter tubing. Quick and easy latching action eliminates need to be in tow vehicle for hook-up.	5.5
GOOSENECK COUPLER OUTER TUBE							
0233010300						Outer tube only. 20" length, 4.5" round tube, with hole for 3/4" load bearing pin, (1) set bolt.	17.2
0233100300						Outer tube only. 20" length, 4.5" round tube, with hole for 3/4" load bearing pin, (2) set bolts.	17.7
REPLACEMENT PART - GOOSENECK COUPLER HEAD GN24 REPAIR KIT							
1542S01	N/A	N/A	N/A		N/A	Kit includes torsion spring, coupler locking shaft, curved handle assembly, 3/4" shaft retaining ring, centerlock nut 1/2-13	N/A
REPLACEMENT PART - GOOSENECK COUPLER KIT							
0287740300	N/A	N/A	N/A		2-5/16"	Kit includes coupler assembly, locking pin assembly, locking pin cover, BULLDOG label, and warning label.	10.0
0233060301	N/A	N/A	N/A		N/A	Replacement Pin Kit, includes cotter pin.	N/A
500296	N/A	N/A	N/A		N/A	Gooseneck couplers bolt kit. Includes jam nut (1), set screw (1), adjusting nut (1).	N/A

SQUARE GOOSENECK ADJUSTABLE COUPLERS

Part No.	Capacity	Overall Height		Adjustment	Ball Size	Description	Unit Wt. Lbs.
		Retracted	Extended				
0289600300	25,000	32"	40"	8"	2-5/16"	4.5" square outer tube, 4.0" square inner tube. (1) 3/4" diameter set screw.	57.0
0288660300	25,000	30.75"	N/A	8"	2-5/16"	4.0" square inner tube only.	42.0
028900	30,000	32"	39"	7"	2-5/16"	4.5" square outer tube with .25" wall, 4.0" square inner tube with .313" wall. Includes topwind crank.	76.0
0289800300	30,000	32"	40"	8"	2-5/16"	4.5" square outer tube with, 4.0" square inner tube. (2) 3/4" diameter set bolts.	68.0

KING PIN GOOSENECK COUPLERS

Part No.	Capacity	Overall Height		Adjustment	Ball Size	Description	Unit Wt. Lbs.
		Retracted	Extended				
0289580300	25,000	23.3"	31.3"	8"	N/A	Round tube , raw finish, labels shipped loose.	57.5
0289640300	25,000	23.3"	31.3"	8"	N/A	Round tube , raw finish, labels shipped loose. Inner tube only.	37.1
0289590300	30,000	23.3"	31.3"	8"	N/A	Square tube , raw finish, labels shipped loose.	64.1
0289650300	30,000	23.3"	31.3"	8"	N/A	Square tube , raw finish, labels shipped loose. Inner tube only.	45.8

SERVICE KIT FOR SQUARE / SQUARE KING PIN GOOSENECK ADJUSTABLE COUPLERS

Part No.	Description
0289SB0140	Adjustable gooseneck pinch bolt kit



BX1® GOOSENECK COUPLERS

The BULLDOG BX1 coupler is the result of generations of design expertise and field experience. It incorporates innovative features that revolutionize the benefits available from a gooseneck coupler.

- Offers flexible mounting options with Next Generation locking plate coupler locking mechanism
- Makes hooking up, adjusting vertical height, and disconnecting easy
- Maintains smooth operation over time with grease fittings for every important operating part
- Operates easily with one hand thanks to new locking handle design
- Continuous tight ball fit - ever-increasing cam tightening mechanism
- Protects against wear with enclosed locking pin mechanism
- Resists theft with integrated feature to allow pad-locking the coupler to the ball (lock not included)
- Guides ball into socket more easily—letting you miss by more than an inch—with bottom locking plate 50% larger than competitors
- Lengthens life of locking mechanism with oil-impregnated bushings
- Allows shorter retracted length and less wasted length for trucks with high bed height via low-profile locking mechanism
- Fits ball better and reduces jarring through contour-formed edge on bottom locking plate
- Delivers unmatched strength through heavy-duty construction
- Innovations that improve security, service life, and functionality
- New ball pocket design provides contact on both sides of the ball for substantially improved pull out strength - the only sliding-plate design that transfers part of the load to the top locking plate rather than only the bottom locking plate

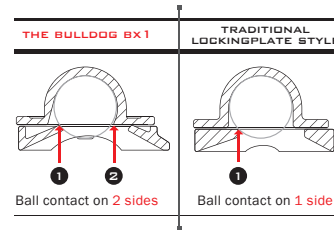

BX1® GOOSENECK COUPLERS

Part No.	Capacity	Overall Height		Adjustment	Ball Size	Description	Unit Wt. Lbs.
		Retracted	Extended				
1289030300	20,000	27.5"	35.5"	8"	2-5/16"	BX1 Coupler Round Tube	46.0
1289070300	20,000	22.6"	30.6"	8"	2-5/16"	BX1 Coupler Round Tube, Short Configuration	41.0
1289170300	20,000	N/A	N/A	8"	2-5/16"	BX1 Coupler Round Tube, Inner Tube Only	27.0
1289000300	25,000	27.5"	35.5"	8"	2-5/16"	BX1 Coupler Round Tube	48.0
1289020300	25,000	N/A	N/A	8"	2-5/16"	BX1 Coupler Round Tube, Inner Tube Only	30.4
1289080300	25,000	22.6"	30.6"	8"	2-5/16"	BX1 Coupler Round Tube, Short Configuration	44.0
1289130300	25,000	30.8"	38.8"	8"	2-5/16"	BX1 Coupler Square Tube	58.6
1289210300	25,000	N/A	N/A	8"	2-5/16"	BX1 Coupler Square, Inner Tube Only, Short Configuration	31.2
1289040300	30,000	22.6"	30.6"	8"	2-5/16"	BX1 Coupler Round Tube, Short Configuration	46.0
1289050300	30,000	N/A	N/A	8"	2-5/16"	BX1 Coupler Round Tube, Inner Tube Only, Short Configuration	29.0
1289140300	30,000	30.8"	38.8"	8"	2-5/16"	BX1 Coupler Square Tube	65.3
1289200300	40,000	22.0"	24.6"	2.6"	3"	BX1 Coupler Square Tube	58.2

ACCESSORIES

0233120300	Square Gooseneck Coupler Outer Tube, Weld On , 20" Length, 4-1/2" Tube, w/Hex Head Bolt Hole, Dual Set Bolts & Labels, 20.6 Lbs.
500356	5/16" Locking Pin for BX1 Gooseneck Couplers

SERVICE KIT

500289	Service kit for BX1 Gooseneck Coupler handle mechanism
--------	--

REPLACEMENT PARTS

500353	Repair Kit (BX1, 3" Ball), Includes Handle Assembly, Locking Cam, Grease Fitting, Grooved Pin, Flanged Bushing & Torsion Spring
--------	---

Patents Pending.

ROUND GOOSENECK COUPLERS

- 8" of Adjustment
- Handle hold-open feature
- Raw Finish
- 2 5/16" Ball Size
- P/N 0287820300 includes loading bearing pin

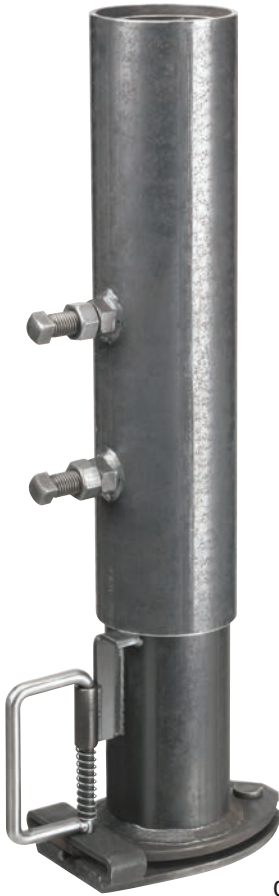

Handle Hold-Open

0287800300



Load Bearing Pin

0287820300

ROUND GOOSENECK COUPLERS

Part No.	Capacity	Overall Height Retracted	Adjustment	Ball Size	Description	Unit Wt. Lbs.
0287790300	20,000	26.70"	8.0"	2-5/16"	Raw Finish, 2 Set Screws	43.00
0287800300	25,000	26.70"	8.0"	2-5/16"	Raw Finish, 2 Set Screws	47.00
0287820300	25,000	26.70"	8.0"	2-5/16"	Raw Finish, 1 Set Screw, Load Bearing Pin	47.00

DRAW-TITE®

THE BRAND OF CHOICE

EST. 1946



TRAILER & VEHICLE ACCESSORIES

BREAKAWAY SYSTEMS

Push to Test Breakaway Systems.....	3
Breakaway Systems.....	4-5
Breakaway Switches.....	6
Sealed Lead Acid Batteries.....	6
Battery Chargers.....	6
Battery Cases.....	6

ELECTRIC TRAILER BRAKE PARTS

Electric Trailer Brake Assemblies.....	7
Self-Adjusting Electric Trailer Brake Assemblies.....	7
Spindle Nut Kits.....	8
Wheel Nuts & Bolts.....	8
Brake Assembly Mounting Bolts.....	8
Bearing Sets.....	8
Electric Trailer Brake Replacement Parts.....	9-15
Magnet Set Replacement Parts.....	16
Replacement Part Reference Guide.....	17-18

WHEEL PROTECTION

Wheel Bearing Kits.....	19
Bearing Protectors.....	19
Grease Caps.....	20
Plastic Fenders.....	21

TRAILER ACCESSORIES

Boat Guides.....	22
Marine Grade Carpeting.....	22
Waterwick™.....	23
Wheel Chocks.....	23
Hitch & Trailer Alignment Tool.....	23
Safety Chains.....	24
D-Rings / Tow Hooks.....	25
Chain Accessories.....	25
Spare Tire Carriers.....	26
Spare Tire Lock.....	26
Outboard Motor Lock.....	27

VEHICLE ACCESSORIES

Adjustable Tow Bars.....	27
Transmission Coolers.....	28
OEM Custom Fitting Kits.....	28

FEATURED PRODUCTS



PUSH TO TEST BREAKAWAY SYSTEM

- LED's indicate fully charged, charging or recharge
- Activates trailer brakes upon separation of trailer and tow vehicle

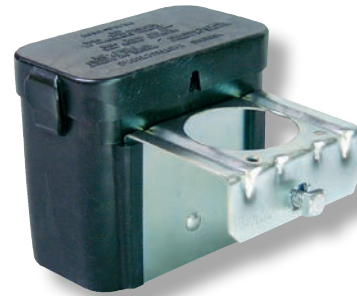

SHUR-SET III® BREAKAWAY SYSTEM

- For use on 1,2,3 and 4 axles trailers equipped with electric brakes
- Breakaway switch included



WHEEL CHOCK

- Made from high impact polymer
- Reduces the risk of trailer roll



SPARE TIRE CARRIER

- » Fits most 4, 5 and 6 lug wheels - up to 16.5"
- » Zinc plated to resist corrosion



OUTBOARD MOTOR LOCK

- Heavy-duty barrel key lock mechanism for maximum security
- Foam filler insert reduces noise and vibration
- Mounts on most outboard motors



WHEEL BEARING KITS

- Designed to fit most hubs used on boats, utility, snowmobile, and RV trailers
- Kit includes 2 bearing cones, 2 bearing cups, grease seal, and cotter pin



PUSH TO TEST BREAKAWAY SYSTEM



50-85-325

- Push to Test: LED's indicate fully charged, charging or recharge
- Multi-Stage Integrated Charger provides a fast recharge up to 12.8 volts. Once battery is fully charged, the automatic float mode is designed to provide a continuous charge without overcharging.
- Activates trailer brakes upon separation of trailer and tow vehicle
- For use on 1, 2 or 3 axle trailers equipped with electric brakes
- Weather/corrosion resistant, heavy-duty polymer case to protect battery & charger
- Quick and easy to install
- Tekonsha Breakaway Switch w/48" lead wires
- 5 Amp/hr Battery
- Battery Box, dimensions – 4.25" x 6.25" x 4.125"
- **3 mounting options!** (Note: third mounting requires optional post mount bracket 5085115)
- Limited 1 year warranty

Note: Make sure battery is fully charged prior to towing.

Part No.	Description	Packaging
50-85-313	Push to Test Breakaway System for 1 to 3 Axle Trailers w/Electric Brakes, Includes Battery Box, 5 Amp Battery w/Push to Test LED Test Meter, Integrated Multi-Stage Charger and Breakaway Switch	Display Box
50-85-325	Push to Test Breakaway System for 1 to 3 Axle Trailers w/Electric Brakes, Includes Battery Box, 5 Amp Battery w/Push to Test LED Test Meter, Integrated Multi-Stage Charger and 48" Tekonsha Breakaway Switch	Display Box



5085115
(Bracket Sold Separately)

ACCESSORY PART

Part No.	Description	Packaging
5085115	Post Mount Bracket	Bulk

PUSH TO TEST BREAKAWAY SYSTEM



50-85-320

- Push to Test: LED's indicate fully charged or recharge
- Built in battery charger charges battery when plugged into the tow vehicle
- Breakaway Switch w/48" lead wires
- 5 Amp/hr Battery
- Activates trailer brakes upon separation of trailer and tow vehicle
- For use on 1, 2, or 3 axle trailers equipped with electric brakes
- **3 mounting options!** (Note: third mounting requires optional post mount bracket 5085115)
- Limited 1 year warranty

Note: Make sure battery is fully charged prior to towing.

Part No.	Description	Packaging
50-85-315	Push to Test Breakaway System for 1 to 3 Axle Trailers w/Electric Brakes, Includes Battery Box, 5 Amp Battery w/Push to Test LED Test Meter and Breakaway Switch	Display Box
50-85-320	Push to Test Breakaway System w/ABCD charger for 1 to 3 Axle Trailers w/Electric Brakes, Includes Battery Box, 5 Amp Battery w/Push to Test LED Test Meter, and 48" Breakaway Switch	Display Box

Accessory Part

Part No.	Description	Packaging
5085115	Post Mount Bracket	Bulk

3 and 4 axle trailers require minimum 5 Amp-hr battery.

For optimal performance, replacement of breakaway electrical components is recommended every 3 to 5 years.



50-85-302



50-85-312



5085115
(Bracket Sold Separately)

BREAKAWAY SYSTEMS

- Activates trailer brakes upon separation of trailer and tow vehicle
- For use on 1, 2 or 3 axle trailers equipped with electric brakes
- Weather/corrosion resistant, heavy-duty polymer case to protect battery and charger
- **P/N 50-85-312 contains battery charger**
- Quick and easy to install
- Breakaway Switch w/7.5" lead wires
- 5 Amp/hr Battery
- Battery Box, dimensions – 5" x 4.125" x 4"
- Flat Surface Mounting (Note: optional post mount bracket available)
- Limited 1 year warranty

Note: Make sure battery is fully charged prior to towing.

Part No.	Description	Packaging
50-85-302	Breakaway System	Boxed
50-85-312	Breakaway System with Charger	Boxed

Accessory Parts

Part No.	Description	Packaging
5085115	Post Mount Bracket	Bulk

3 and 4 axle trailers require minimum 5 Amp-hr battery.

For optimal performance, replacement of breakaway electrical components is recommended every 3 to 5 years.



BREAKAWAY SYSTEMS

For use on 1, 2, 3 and 4 axle trailers equipped with electric brakes. These complete systems incorporate the highest quality components in trailer breakaway systems. Meet or exceed Department of Transportation (DOT) specifications regarding trailer breakaway and holding requirements. If a breakaway occurs between your tow vehicle and your trailer, the breakaway systems will automatically apply consistent braking power to your trailer brakes. Quick and easy to install, the systems comes with a weather/corrosion resistant, heavy-duty polymer case to protect the battery and charger.



1026 / 1028 / 2026 / 2028 Systems & 2018 Case

BREAKAWAY SYSTEM - FOR USE ON 1 & 2 AXLE TRAILERS WITH ELECTRIC BRAKES.

Part No.	Description	Packaging
1026	Includes 2018 Polymer Battery Case w/A-Frame or Post Mounting Bracket; 2023 Rechargeable Sealed 12v 5 Amp-hr Lead Acid Battery & Terminals; 2005-P Breakaway Switch.	Display Box



20005 / 20015 Systems & 2051 Case

BREAKAWAY SYSTEM - FOR USE ON 1, 2, 3 & 4 AXLE TRAILERS WITH ELECTRIC BRAKES.

Part No.	Description	Packaging
2026	Includes 2018 Polymer Battery Case w/A-Frame or Post Mounting Bracket; 2023 Rechargeable Sealed 12v 5 Amp-hr Lead Acid Battery & Terminals; 2010-P Breakaway Switch.	Display Box
20005	Includes 2051 Lockable All Polymer Battery Case w/Flat Surface Mounting; 2023 Rechargeable Sealed 12v 5 Amp-hr Lead Acid Battery & Terminals; 2010-P Breakaway Switch.	Display Box
20010	Includes 20000 Lockable Polymer Battery Case w/Weldable Flat Surface Mounting; 2023 Rechargeable Sealed 12v 5 Amp-hr Lead Acid Battery & Terminals; 2010-P Breakaway Switch.	Display Box

BREAKAWAY SYSTEM WITH CHARGER - FOR USE ON 1, & 2 AXLE TRAILERS WITH ELECTRIC BRAKES.

Part No.	Description	Packaging
1028	Includes 2018 Polymer Battery Case w/A-Frame or Post Mounting Bracket; 2023 Rechargeable Sealed 12v 5 Amp-hr Lead Acid Battery & Terminals; 2005-P Breakaway Switch; 1024 DC-to-DC Accelerated Battery Charging Device (ABCD).	Display Box



20010 / 20020 Systems & 20000 Case

BREAKAWAY SYSTEM WITH MULTI-STAGE INTEGRATED CHARGER - FOR USE ON 1, 2, 3 & 4 AXLE TRAILERS WITH ELECTRIC BRAKES.

Part No.	Description	Packaging
2028	Includes 2018 Polymer Battery Case w/A-Frame or Post Mounting Bracket; 2023 Rechargeable Sealed 12v 5 Amp-hr Lead Acid Battery & Terminals; 2010-P Breakaway Switch; 2024-07 DC-to-DC Heavy Duty Quick/Maintenance (Multi Stage) Battery Charger.	Display Box
20015	Includes 2051 Lockable All Polymer Battery Case w/Flat Surface Mounting; 2023 Rechargeable Sealed 12v 5 Amp-hr Lead Acid Battery & Terminals; 2010-P Breakaway Switch; 2024-07 DC-to-DC Heavy Duty Quick/Maintenance (Multi Stage) Battery Charger.	Display Box
20020	Includes 20000 Lockable Polymer Battery Case w/Weldable Flat Surface Mounting; 2023 Rechargeable Sealed 12v 5 Amp-hr Lead Acid Battery & Terminals; 2010-P Breakaway Switch; 2024-07 DC-to-DC Heavy Duty Quick/Maintenance (Multi Stage) Battery Charger.	Display Box



Battery Terminals Included in systems

3 and 4 axle trailers require minimum 5 Amp-hr battery.

For optimal performance, replacement of breakaway electrical components is recommended every 3 to 5 years.



50-85-007 Switch



2010 Switch



2005 Switch



2009 Switch



2023 Battery

Most states require breakaway switch with separate power supply when towing a trailer.



2024-07 Charger



2025-09 Charger



1024/50-85-104 Charger

BREAKAWAY SWITCHES

Completely sealed breakaway switches to automatically set trailer brakes in case of accidental trailer breakaway. Required by law in some states. Emergency use only, not to be used to lock brakes when parked or stored. 2010, 50-85-007 and 2005 have reinforced nylon case, weldable metal tab, nylon pin assembly and are rust and corrosion free. 2009 has all metal parts and a brass pin assembly.

Part No.	Description	Packaging
50-85-007	Breakaway Switch w/ 48" wires w/Cable & Nylon Pin Assembly	Bulk
54-85-007	Breakaway Switch w/ 48" wires w/Cable & Nylon Pin Assembly	Bagged
2010-B125	Breakaway Switch w/ 48" wires w/Cable & Nylon Pin Assembly	Bulk
2010-P	Breakaway Switch w/ 48" wires w/Cable & Nylon Pin Assembly	Clam
2005-B120	Breakaway Switch w/ 48" wires w/Cable & Nylon Pin Assembly (for use with 1-3 axle trailers)	Bulk
2005-P	Breakaway Switch w/ 48" wires w/Cable & Nylon Pin Assembly (for use with 1-3 axle trailers)	Clam
2009-B60	Breakaway Switch w/ 48" wires w/Cable & Brass Pin Assembly	Bulk
2009-P	Breakaway Switch w/ 48" wires w/Cable & Brass Pin Assembly	Clam

REPLACEMENT PARTS

Part No.	Description	Packaging
50-85-002	48" Replacement Cable & Nylon Pin Assembly (for 50-85-007 Switch)	Bulk
54-85-002	48" Replacement Cable & Nylon Pin Assembly (for 50-85-007 Switch)	Bagged
2010-A	48" Replacement Cable & Nylon Pin Assembly (for 2010 Switch)	Bulk
2010-A-P	48" Replacement Cable & Nylon Pin Assembly (for 2010 Switch)	Clam
2005-A	48" Replacement Cable & Nylon Pin Assembly (for 2005 Switch)	Bulk
2009-A	48" Replacement Cable & Brass Pin Assembly (for 2009 Switch)	Bulk
2009-A-P	48" Replacement Cable & Brass Pin Assembly (for 2009 Switch)	Clam

SEALED LEAD ACID BATTERY

12v, sealed lead acid battery for use with Breakaway Systems on single, tandem and tri-axle trailers equipped with electric brakes. Battery requires periodic recharging to maintain optimum performance.

Part No.	Description	Packaging
2023	5 Amp-hr Sealed Battery	Bulk
2023-X	5 Amp-hr Sealed Battery	Display Box

BATTERY CHARGERS

For all 12v battery systems with a 4 Amp-hr minimum output. 2024-07 is designed to fit securely into the Breakaway Battery Cases. Temperature compensated design provides continuous recharge with automatic float mode feature to prevent overcharging. 1024/50-85-104 will return trailer breakaway system batteries to their maximum potential. Patent pending. 2025-09 features an automatic float mode to prevent overcharging. Ideal for seasonal storage and maintenance of recreational vehicles, motorcycles, snowmobiles, lawn tractors, and more.

Part No.	Description	Packaging
50-85-104	DC-to-DC Accelerated Battery Charging Device (ABCD)	Bulk
1024	DC-to-DC Accelerated Battery Charging Device (ABCD)	Clam
2024-07	DC-to-DC Heavy Duty Multi Stage/Maintenance Charger	Bulk
2024-07-S	DC-to-DC Heavy Duty Multi Stage/Maintenance Charger	Clam
2025-09	AC-to-DC Multi Stage Maintenance Charger	Clam

BATTERY CASES

Rust-proof heavy duty polymer cases protect battery and charger from elements and corrosion. Featuring U-shaped clamp style fastener on #2018 to mount over most trailer tongues, #2051/5085102 is a lockable case, and #20000 features a galvanized metal mounting bracket with locking bar for secure battery protection.

Part No.	Description	Packaging
2018	Battery Case - One-Bolt Installation on Jackpost or A-Frame	Bulk
2051	Battery Case - Four-Bolt Installation on Flat Surface	Bulk
50-85-102	Battery Case - Four-Bolt Installation on Flat Surface	Bulk
20000	Battery Case - Two-Bolt or Weldable Installation on Flat Surface	Bulk



ELECTRIC TRAILER BRAKE ASSEMBLIES

- Units are assembled
- Assemblies include: Backing Plate, Shoe and Linings, Magnets, Actuating Lever, Adjusting Screw and Spring Hardware.

Part No.	Description	Packaging
5707	10" x 2 1/4" L.H. Dexter Assembly	Boxed
5708	10" x 2 1/4" R.H. Dexter Assembly	Boxed
5711	12" x 2" L.H. Dexter Assembly	Boxed
5712	12" x 2" R.H. Dexter Assembly	Boxed
5713-HA	12" x 2" L.H. Hayes Assembly (Replace in Pairs)	Boxed
5714-HA	12" x 2" R.H. Hayes Assembly (Replace in Pairs)	Boxed
6709TEK	10" x 2 1/4" L.H. AL-KO Assembly	Boxed
6710	10" x 2 1/4" R.H. AL-KO Assembly	Boxed
6713	12" x 2" L.H. AL-KO Assembly	Boxed
6714	12" x 2" R.H. AL-KO Assembly	Boxed

SELF-ADJUSTING ELECTRIC TRAILER BRAKE ASSEMBLIES

- Replaces Dexter Electric Trailer Brake Assemblies
- Self Adjusting
- Units are assembled
- Replace in pairs
- Assemblies include: Backing Plate, Shoe and Linings, Magnets, Actuating Lever and Spring Hardware.

Part No.	Description	Packaging
54801-005	10 x 2 1/4 Right Hand Brake Assembly - Self-Adjusting	Boxed
54801-006	10 x 2 1/4 Left Hand Brake Assembly - Self-Adjusting	Boxed
54801-007	12 x 2 Right Hand Brake Assembly - Self-Adjusting	Boxed
54801-008	12 x 2 Left Hand Brake Assembly - Self-Adjusting	Boxed

ELECTRIC TRAILER BRAKE ASSEMBLIES

- Replaces Dexter Electric Trailer Brake Assemblies
- Units are assembled
- Assemblies include: Backing Plate, Shoe and Linings, Magnets, Actuating Lever, Adjusting Screw and Spring Hardware.

Part No.	Description	Packaging
54801-001	10 x 2 1/4 Right Hand Brake Assembly	Boxed
54801-002	10 x 2 1/4 Left Hand Brake Assembly	Boxed
54801-003	12 x 2 Right Hand Brake Assembly	Boxed
54801-004	12 x 2 Left Hand Brake Assembly	Boxed
54801-023	10 x 2 1/4 Right Hand Brake Assembly	Bulk
54801-024	10 x 2 1/4 Left Hand Brake Assembly	Bulk
54801-025	12 x 2 Right Hand Brake Assembly	Bulk
54801-026	12 x 2 Left Hand Brake Assembly	Bulk

SKID QUANTITIES

54801-126R	12 x 2 Right Hand Brake Assembly	126 per skid
54801-126L	12 x 2 Left Hand Brake Assembly	126 per skid
54801-156R	10 x 2-1/4 Right Hand Brake Assembly	156 per skid
54801-156L	10 x 2-1/4 Left Hand Brake Assembly	156 per skid





Spindle Nuts Kits - Standard Washer



Spindle Nuts Kits - D Type Washer

SPINDLE NUT KITS

Secures brake hardware on spindle axles.

Part No.	Description	Packaging
5774	Spindle Nut Kit - Standard Washer - (1" - 14 Spindle)	Clam Shell
5775	Spindle Nut Kit - D Type Washer - (1" - 14 Spindle)	Clam Shell



Wheel Nuts



Wheel Bolts

WHEEL NUTS/BOLTS

Secures wheel to brake drum.

Part No.	Description	Packaging
5780TEK	13/16 Wheel Nut - (1/2 - 20) - Set of 5	Clam Shell
5787	Wheel Bolt - (1/2 - 20) - Set of 5	Clam Shell



BRAKE ASSEMBLY MOUNTING BOLTS

Part No.	Description	Packaging
5720	3/8" Brake Assembly Mounting Bolt (Used on 5 bolt mounting patterns)	Clam Shell
5721	7/16" Brake Assembly Mounting Bolt (Used on 4 bolt mounting patterns)	Clam Shell



BEARING SETS

Part No.	Cup	Cone	Packaging
5508	14276	14125A	Clam Shell
5509	15245	15123	Clam Shell
5503	25520	25580	Clam Shell
5502	L44610	L44649	Clam Shell
5506	LM48510	LM48548	Clam Shell
5507	LM67010	LM67048	Clam Shell
5505	L68111	L68149	Clam Shell



ALKO 10" x 2 1/4"

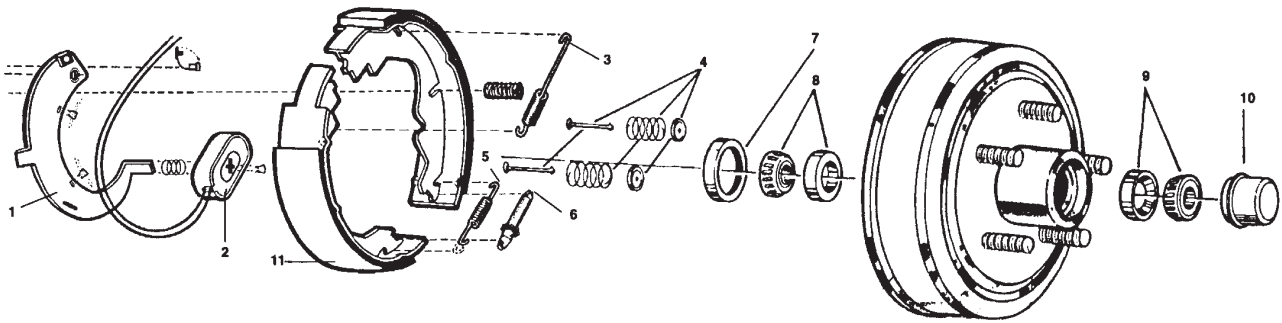

Tekonsha Part No.	Illustration No.	Description
Hardware		
6106	2	Magnet Kit
5304	3	Return Spring Set (Axle Set)
5353	4	Hold Down Kit (Axle Set)
5404	5,6	Adjusting Screw Kit (Spring & Screw Assembly)

Tekonsha Part No.	Illustration No.	Description
Grease Seal & Cap		
6604/5604	7	Seal (Axle Set)
5651	10	Grease Cap (Axle Set)
Bearing Sets		
5505	8	Bearing Set - Inner
5502	9	Bearing Set - Outer
Brake Shoes		
6004	11	Shoe and Lining Kit (Wheel Set)
Brake Assembly		
6709TEK		Complete Assembly - L.H.
6710		Complete Assembly - R.H.

ALKO 12" x 2"

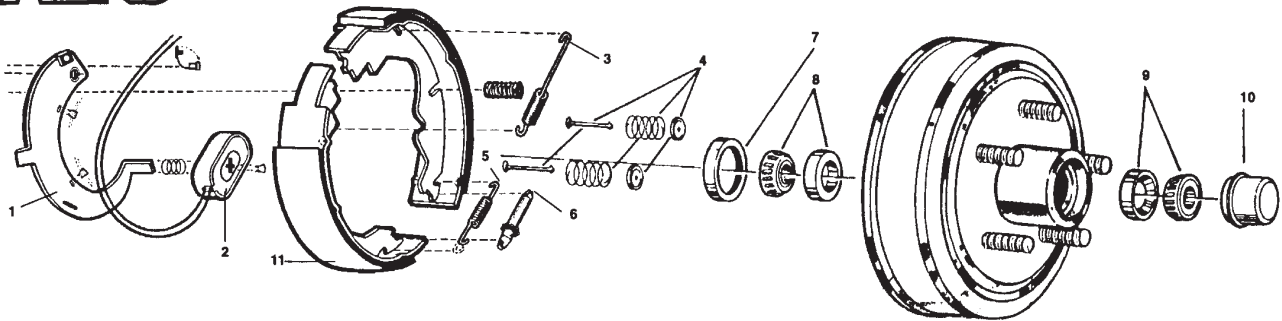

Tekonsha Part No.	Illustration No.	Description
Hardware		
6109	2	Magnet Kit 6K & 7K
5307	3	Return Spring Set (Axle Set)
5353	4	Hold Down Kit (Axle Set)
5404	5,6	Adjusting Screw Kit (Spring & Screw Assembly)

Tekonsha Part No.	Illustration No.	Description
Grease Seal & Cap		
6605/5605	7	Seal (Axle Set) (Replace in Pairs)
6658	10	Grease Cap (Axle Set) for 5508
5652	10	Grease Cap (Axle Set) for 5509
Bearing Sets		
5503	8	Bearing Set - Inner
5508	9	Bearing Set - Outer - 865 Large Bore
5509	9	Bearing Set - Outer - Small Bore
Brake Shoes		
6005	11	Shoe and Lining Kit (Wheel Set)
Brake Assembly		
6713		Complete Assembly - L.H.
6714		Complete Assembly - R.H.

Dexter 7" x 1 1/4"

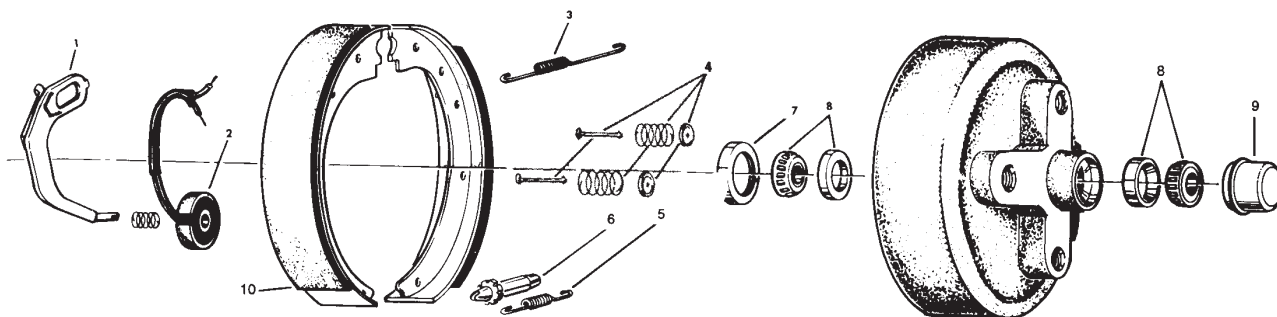

Tekonsha Part No.	Illustration No.	Description
Hardware		
(N/A)	1	Actuating Lever - R.H.
(N/A)	1	Actuating Lever - L.H.
(N/A)	2	Magnet Kit
5113***	2	Magnet Kit
Hardware (Axle Set)		
5320*	3	Return Spring
5320*	4	Hold Down Clips
5320*	5	Adjusting Screw Spring
5320*	6	Adjusting Screw Assembly

Tekonsha Part No.	Illustration No.	Description
Grease Seal & Cap		
5603	7	Seal - BTR (Axle Set)
5651	9	Grease Cap (Axle Set)
Bearing Sets		
5502	8	Bearing Set - Inner & Outer
Brake Shoes		
5002	10	Shoe and Lining Kit (Wheel Set)

*Contained in Hardware Kit (Axle Kit)

***5113 After 4-1990

(N/A) - No Longer Available

Dexter 10" x 1 1/2"

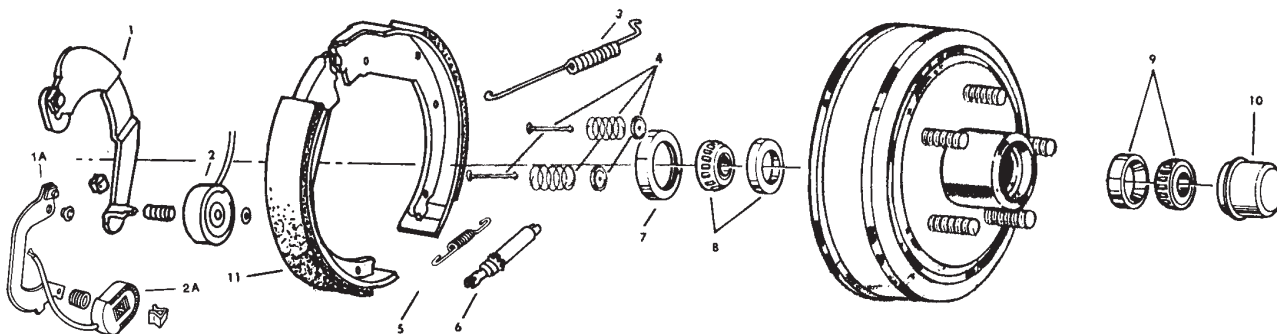

Tekonsha Part No.	Illustration No.	Description
Hardware		
(N/A)	1	Actuating Lever - R.H.
(N/A)	1A	Actuating Lever - R.H.
(N/A)	1	Actuating Lever - L.H.
(N/A)	1A	Actuating Lever - L.H.
5113*	2	Magnet Kit
5118**	2A	Magnet Kit
5306	3	Return Spring Set (Axle Set)
(N/A)	4	Hold Down Kit (Axle Set)
5404	5,6	Adjusting Screw Kit (Spring & Screw Assembly)

Tekonsha Part No.	Illustration No.	Description
Grease Seal & Cap		
5607	7	Seal (Axle Set)
5651	10	Grease Cap (Axle Set)
Bearing Sets		
5507	8	Bearing Set - Inner
5502	9	Bearing Set - Outer
Brake Shoes		
5009	11	Shoe and Lining Kit (Wheel Set)

*Prior to Mid 1988

**After Mid 1988

(N/A) - No Longer Available



Dexter 10" x 2 1/4"

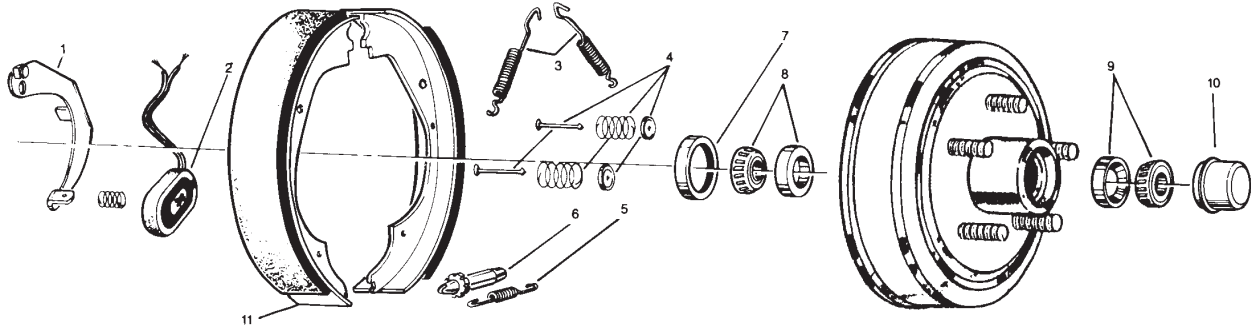

Tekonsha Part No.	Illustration No.	Description
Hardware		
5106	2	Magnet Kit
5305	3	Return Spring Set (Axle Set)
5353	4	Hold Down Kit (Axle Set)
5404	5,6	Adjusting Screw Kit (Spring & Screw Assembly)

Tekonsha Part No.	Illustration No.	Description
Grease Seal & Cap		
5604	7	Seal (Axle Set)
5651	10	Grease Cap (Axle Set)
Bearing Sets		
5506	8	Bearing Set - Inner (Prior to Dec. 1983)
5505	8	Bearing Set - Inner (After Dec. 1983)
5502	9	Bearing Set - Outer
Brake Shoes		
5003	11	Shoe and Lining Kit (Wheel Set)
Brake Assembly		
5707		Complete Assembly - L.H.
5708		Complete Assembly - R.H.

Dexter 12" x 2"

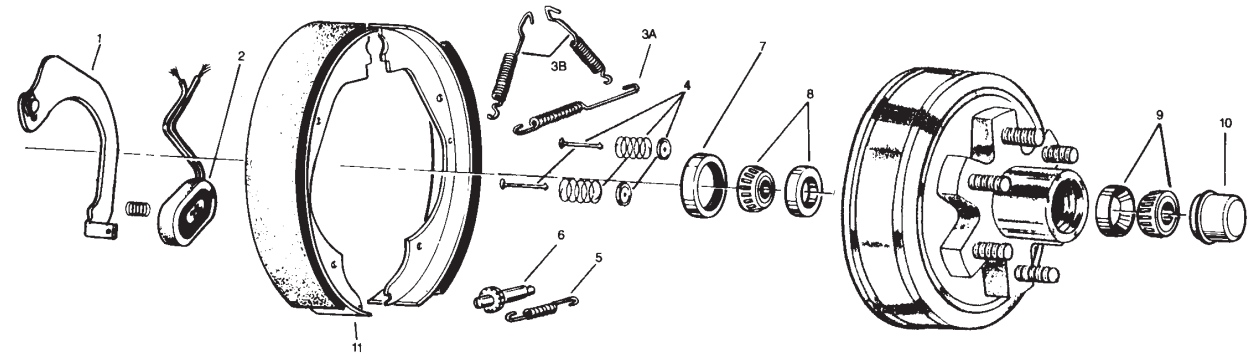

Tekonsha Part No.	Illustration No.	Description
Hardware		
5109	2	Magnet Kit
Return Spring Set (Axle Set)		
5307	3A	Single Retractor
5305	3B	Dual Retractor
5353*	4	Hold Down Kit (Axle Set)
5404	5,6	Adjusting Screw Kit (Spring & Screw Assembly)

Tekonsha Part No.	Illustration No.	Description
Grease Seal & Cap		
5606**	7	Seal (Axle Set)
5608***	7	Seal (Axle Set)
5652	10	Grease Cap (Axle Set)
Bearing Sets		
5503	8	Bearing Set - Inner
5507	9	Bearing Set - Outer
Brake Shoes		
5000-DX	11	Shoe and Lining Kit (Wheel Set)
Brake Assembly		
5711		Complete Assembly - L.H.
5712		Complete Assembly - R.H.

*Replacement Kit Uses Coil Springs
 **Prior to 1997
 ***After 1997 (A Series Only)

Dexter 12" x 2" 7K

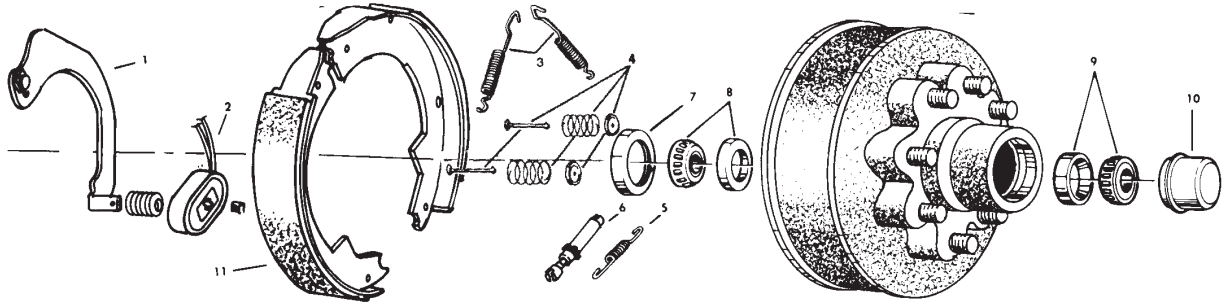

Tekonsha Part No.	Illustration No.	Description
Hardware		
5114	2	Magnet Kit
5305	3	Return Spring Set (Axle Set)
5353	4	Hold Down Kit (Axle Set)
5404	5,6	Adjusting Screw Kit (Spring & Screw Assembly)

Tekonsha Part No.	Illustration No.	Description
Grease Seal & Cap		
5606*	7	Seal (Axle Set)
5608**	7	Seal (Axle Set)
5652	10	Grease Cap (Axle Set)
Bearing Sets		
5503	8	Bearing Set - Inner
5508	9	Bearing Set - Outer (865 HUB)
5509	9	Bearing Set - Outer (UTG Hub)
Brake Shoes		
5010	11	Shoe and Lining Kit (Wheel Set)

*Prior to 1997

**After 1997 (A Series Only)

Hayes 10" x 1 5/8"

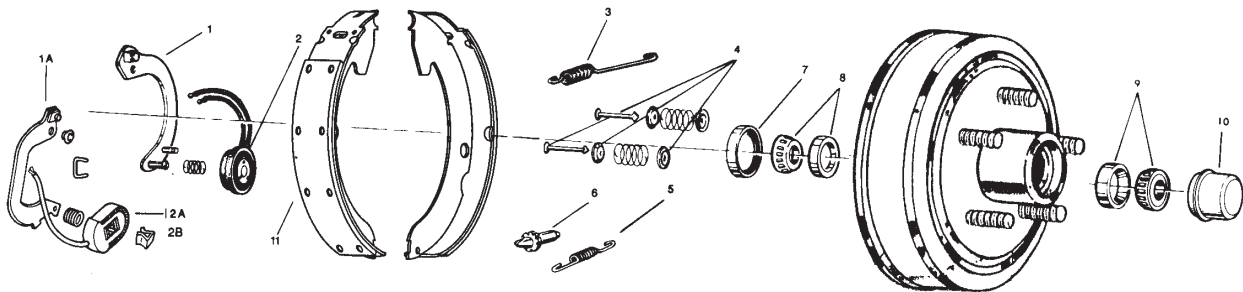

Tekonsha Part No.	Illustration No.	Description
Hardware		
(N/A)	1	Actuating Lever - R.H.
(N/A)	1A	Actuating Lever - R.H.
(N/A)	1	Actuating Lever - L.H.
(N/A)	1A	Actuating Lever - L.H.
5106**	2A	Magnet Kit (6K & 7K Axles)
5101-HA***	2B	Magnet Kit - White Wire
5304	3	Return Spring Set (Axle Set)
(N/A)	4	Hold Down Kit (Axle Set)
5404	5,6	Adjusting Screw Kit (Spring & Screw Assembly)

Tekonsha Part No.	Illustration No.	Description
Grease Seal & Cap		
5604	7	Seal (Axle Set)
5651	10	Grease Cap (Axle Set)
Bearing Sets		
5507	8	Bearing Set - Inner
5502	9	Bearing Set - Outer
Brake Shoes		
(N/A)	11	Shoe and Lining Kit (Wheel Set)

*Prior to Mid 1987

**After Mid 1987

***After Late 1994 (Replace in Pairs)

(N/A) - No Longer Available

TRAILER BRAKES REPLACEMENT PARTS



Hayes 10" x 2 1/4"

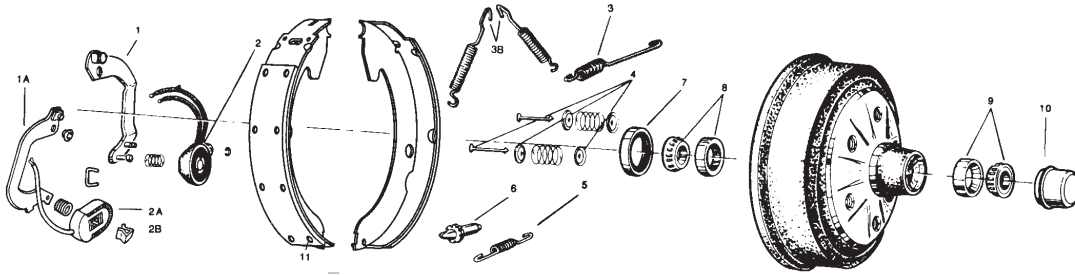

Tekonsha Part No.	Illustration No.	Description
Hardware		
(N/A)	1	Actuating Lever - R.H.
(N/A)	1A	Actuating Lever - R.H.
(N/A)	1	Actuating Lever - L.H.
(N/A)	1A	Actuating Lever - L.H.
5106**	2A	Magnet Kit
5101-HA	2B	Magnet Kit-White Wire After Late 1994 (Replace in Pairs)
Return Spring Set (Axle Set)		
5304	3A	Single Retractor
5305****	3B	Dual Retractor
5353	4	Hold Down Kit (Axle Set)
5404	5,6	Adjusting Screw Kit (Spring & Screw Assembly)

Tekonsha Part No.	Illustration No.	Description
Grease Seal & Cap		
5604	7	Seal (Axle Set)
5651	10	Grease Cap (Axle Set)
Bearing Sets		
5505***	8	Bearing Set - Inner
5502	9	Bearing Set - Outer
Brake Shoes		
6004	11	Shoe and Lining Kit (Wheel Set)
Brake Assembly		
(N/A)		Complete Assembly - L.H. (Replace in Pairs)
(N/A)		Complete Assembly - R.H. (Replace in Pairs)

*Prior to Mid 1987
 **After Mid 1987
 ***After 1972
 ****Prior to May 1977
 (N/A) - No Longer Available

Hayes 12" x 2"

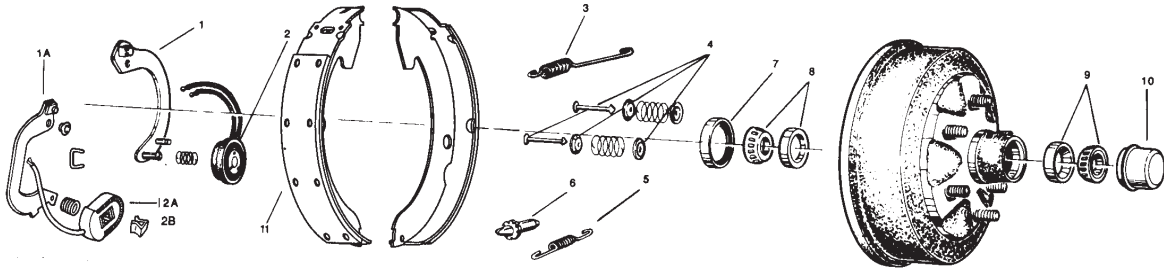

Tekonsha Part No.	Illustration No.	Description
Hardware		
(N/A)	1	Actuating Lever - R.H.
(N/A)	1	Actuating Lever - L.H.
(N/A)	2	Magnet Kit
5109**	2A	Magnet Kit
5101-HA	2B	Magnet Kit-White Wire After Late 1994 (Replace in Pairs)
5307	3	Return Spring Set (Axle Set)
5353	4	Hold Down Kit (Axle Set)
5404	5,6	Adjusting Screw Kit (Spring & Screw Assembly)

Tekonsha Part No.	Illustration No.	Description
Grease Seal & Cap		
5605	7	Seal (Axle Set)
5652	10	Grease Cap (Axle Set)
Bearing Sets		
5503	8	Bearing Set - Inner
5507	9	Bearing Set - Outer
Brake Shoes		
(N/A)	11	Shoe and Lining Kit (Wheel Set)
Brake Assembly		
5713-HA		Complete Assembly - L.H. (Replace in Pairs)
5714-HA		Complete Assembly - R.H. (Replace in Pairs)

**After Late 1987
 (N/A) - No Longer Available

Hayes 12" x 2" Centerline

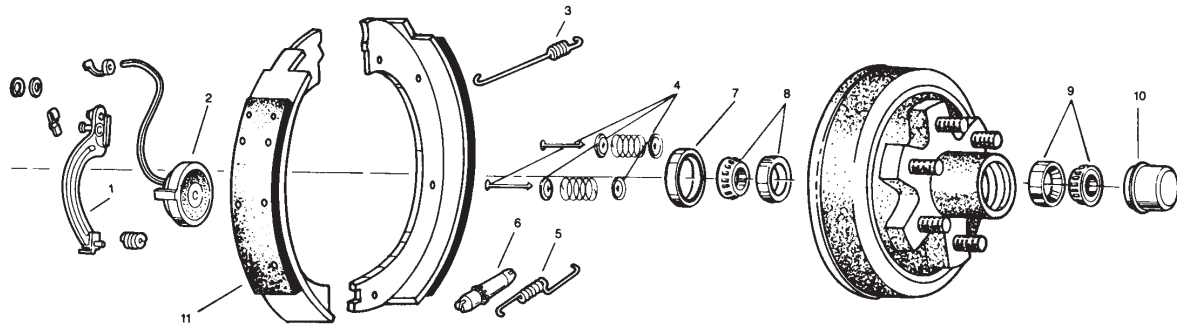

Tekonsha Part No.	Illustration No.	Description
Hardware		
(N/A)	1	Actuating Lever - R.H.
(N/A)	1	Actuating Lever - L.H.
(N/A)	1	Actuating Lever - R.H.
(N/A)	1	Actuating Lever - L.H.
(N/A)	2	Magnet Kit (4.5K Axles)
(N/A)	2	Magnet Kit (6K & 7K Axles)
(N/A)	3	Return Spring Set (Axle Set)
5353	4	Hold Down Kit (Axle Set)
5404	5,6	Adjusting Screw Kit (Spring & Screw Assembly)

Tekonsha Part No.	Illustration No.	Description
Grease Seal & Cap		
5605	7	Seal (Axle Set)
5652	10	Grease Cap (Axle Set)
Bearing Sets		
5503	8	Bearing Set - Inner
5507	9	Bearing Set - Outer
Brake Shoes		
(N/A)	11	Shoe and Lining Kit (Wheel Set) (4.5K and 6K Axles)
(N/A)	11	Shoe and Lining Kit (Wheel Set) (7K Axles)

(N/A) - No Longer Available

Fayette 10" x 2 1/4"

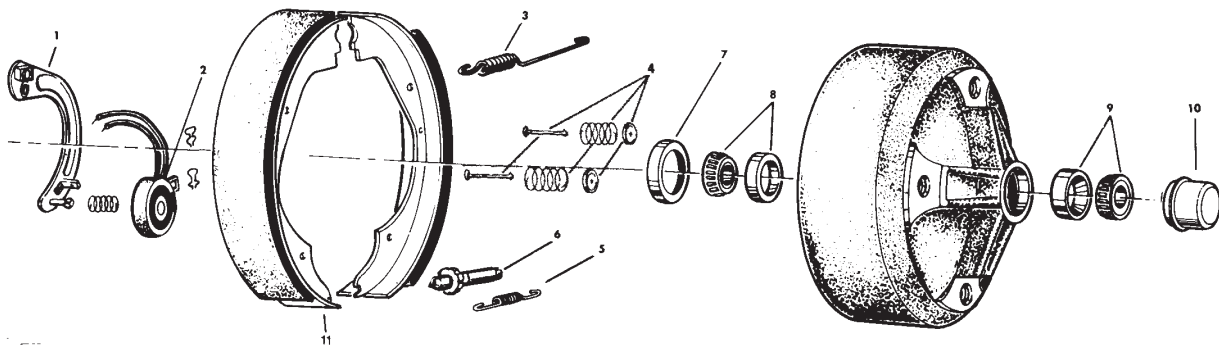

Tekonsha Part No.	Illustration No.	Description
Hardware		
(N/A)	1	Actuating Lever - R.H.
(N/A)	1	Actuating Lever - L.H.
(N/A)	2	Magnet Kit
5304	3	Return Spring Set (Axle Set)
5353*	4	Hold Down Kit (Axle Set)
5404	5,6	Adjusting Screw Kit (Spring & Screw Assembly)

Tekonsha Part No.	Illustration No.	Description
Grease Seal & Cap		
5604	7	Seal (Axle Set)
5651	10	Grease Cap (Axle Set)
Bearing Sets		
5505***	8	Bearing Set - Inner
5502	9	Bearing Set - Outer
Brake Shoes		
(N/A)	11	Shoe and Lining Kit (Wheel Set)

*Contained in Hardware Kit (Axle Kit)

***After 1972

(N/A) - No Longer Available



Fayette 12" x 2"

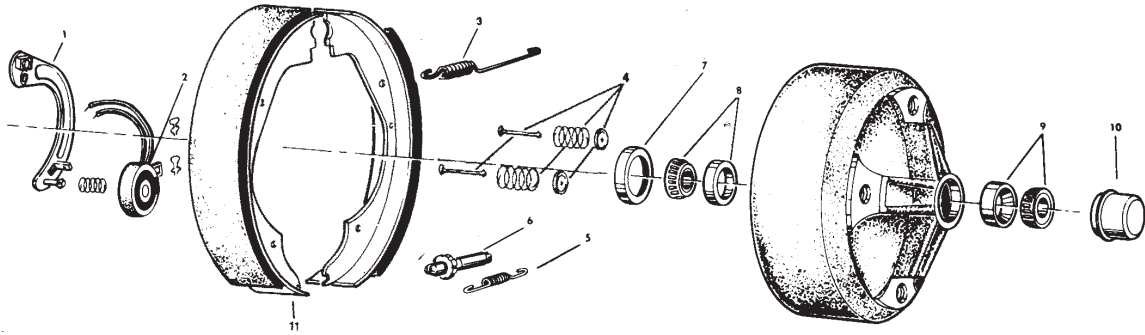

Tekonsha Part No.	Illustration No.	Description
Hardware		
(N/A)	1	Actuating Lever - R.H.
(N/A)	1	Actuating Lever - L.H.
(N/A)	2	Magnet Kit
5307	3	Return Spring Set (Axle Set)
5353*	4	Hold Down Kit (Axle Set)
5404	5,6	Adjusting Screw Kit (Spring & Screw Assembly)

*Replacement Kit Uses Coil Springs

**Bonded Shoes

(N/A) - No Longer Available

Tekonsha Part No.	Illustration No.	Description
Grease Seal & Cap		
5605	7	Seal (Axle Set)
5652	10	Grease Cap (Axle Set)
Bearing Sets		
5503	8	Bearing Set - Inner
5507	9	Bearing Set - Outer
Brake Shoes		
5000-DX**	11	Shoe and Lining Kit (Wheel Set)



5101-HA – White Wires

Length 3 1/8
 Width 2
 Thickness 15/16
 Fits or Replaces
 Hayes 10 x 1 5/8
 10 x 2 1/4
 12 x 2



(All - Replaces in pairs)
 (All - After Late 1994)

5106 – Green Wires

Length 3 1/8
 Width 2
 Thickness 15/16
 Fits or Replaces
 Dexter 10 x 2 1/4
 Hayes 10 x 2 1/4
 (After Mid 1987)
 Hayes 10 x 1 5/8
 (After Mid 1987)
 Trailer Pac 102
 Tow Craft 1103-100-017



5109 – White Wires

Length 3 1/8
 Width 2
 Thickness 15/16
 Fits or Replaces
 Dexter 12 x 2
 Hayes 12 x 2
 (After Late 1987)
 Trailer Pac 103
 Tow Craft 1103-100-018



5113 – White Wires

Length 2 1/16
 Width 1 15/16
 Thickness 3/4
 Fits or Replaces
 Dexter 10 x 1 1/2
 (Prior to Mid 1988)
 Dexter 7 x 1 1/4
 (After April 1990)



5114 – Black Wires

Length 3 1/8
 Width 2
 Thickness 15/16
 Fits or Replaces
 Dexter 12 x 2 - 7K Axles



5118 – Yellow Wires

Length 3 1/8
 Width 2
 Thickness 15/16
 Fits or Replaces
 Dexter 10 x 1 1/2
 (After Mid 1988)



6106 – Light Green Wires

Length 3 1/8
 Width 2
 Thickness 15/16
 Fits or Replaces
 AL-KO Kober 10 x 2 1/4



6109 – White Wires

Length 3 1/8
 Width 2
 Thickness 15/16
 Fits or Replaces
 AL-KO Kober 12 x 2 6K & 7K





Brake Assembly

Part No.	Description	Packaging
5707	10 x 2 1/4 Dexter (L.H.)	Boxed
5708	10 x 2 1/4 Dexter (R.H.)	Boxed
5711	12 x 2 Dexter (L.H.)	Boxed
5712	12 x 2 Dexter (R.H.)	Boxed
*5713-HA	12 x 2 Hayes (L.H.)	Boxed
*5714-HA	12 x 2 Hayes (R.H.)	Boxed
6709TEK	10 x 2 1/4 AL-KO (L.H.)	Boxed
6710	10 x 2 1/4 AL-KO (R.H.)	Boxed
6713	12 x 2 AL-KO (L.H.)	Boxed
6714	12 x 2 AL-KO (R.H.)	Boxed

Brake Assembly Mounting Bolts

Part No.	Description	Packaging
5720	3/8" 5 Bolt Mounting Pattern	Clam Shell
5721	7/16" 4 Bolt Mounting Pattern	Clam Shell

Magnet Kit

Part No.	Description	Packaging
*5101-HA	10 x 1 5/8 Hayes (After late 1994) 10 x 2 1/4 Hayes (After late 1994) 10 x 2 1/4 Hayes (After late 1994)	Boxed
5106	10 x 2 1/4 Dexter 10 x 2 1/4 Hayes (After Mid 1987) 10 x 1 5/8 Hayes (6K&7K Axles) (After Mid 1987)	Boxed
5109	12 x 2 Dexter 12 x 2 Hayes (After Late 1987)	Boxed
5113	10 x 1 1/2 Dexter (Prior to Mid 1988) 7 x 1 1/4 Dexter (After April 1990)	Boxed
5114	12 x 2 Dexter 7K	Boxed
5118	10 x 1 1/2 Dexter (After Mid 1988)	Boxed
6106	10 x 2 1/4 AL-KO	Boxed
6109	12 x 2 AL-KO 6K & 7K	Boxed

Magnet Retaining Ring (Not Pictured)

Part No.	Description	Packaging
5120TEK	10 x 1 5/8 Hayes 10 x 2 1/4 Hayes (Old Style) 12 x 2 Hayes (Old Style)	Clam Shell

Magnet Retaining Clip (Not Pictured)

Part No.	Description	Packaging
5121TEK	10 x 2 1/4 Dexter 12 x 2 Dexter 12 x 2 Dexter 7K 10 x 2 1/4 Hayes (New Style) 12 x 2 Hayes (New Style)	Clam Shell

Wire Clip (Not Pictured)

Part No.	Description	Packaging
5122	10 x 1 1/2 Dexter 10 x 2 1/4 Dexter 12 x 2 Dexter	Clam Shell

Grease Cap (Axle Set)

Part No.	Description	Packaging
5651	7 x 1 1/4 Dexter 10 x 2 1/4 AL-KO 10 x 1 5/8 Hayes 10 x 1 1/2 Dexter 10 x 2 1/4 Hayes 10 x 2 1/4 Dexter 10 x 2 1/4 Fayette 10 x 2 1/4 Foreman	Clam Shell
5652	12 x 2 AL-KO (Small Bore) 12 x 2 Hayes & 12 x 2 Hayes Centerline 12 x 2 Dexter & 12 x 2 Dexter 7K 12 x 2 Fayette 12 x 2 Foreman	Clam Shell
6658	12 x 2 AL-KO (Large Bore)	Clam Shell

Grease Seal (Axle Set)

Part No.	Description	Packaging
5602	7 1/4 x 1 1/4 Hayes	Clam Shell
5603	7 x 1 1/4 Dexter (BTR)	Clam Shell
5604	10 x 1 5/8 Hayes 10 x 2 1/4 AL-KO 10 x 2 1/4 Hayes 10 x 2 1/4 Dexter 10 x 2 1/4 Fayette	Clam Shell
5605	12 x 2 Hayes & 12 x 2 Hayes Centerline 12 x 2 Fayette 12 x 2 AL-KO*	Clam Shell
5606	12 x 2 Dexter (Prior 1997) & 12 x 2 Dexter 7K (Prior 1997)	Clam Shell
5607	10 x 1 1/2 Dexter	Clam Shell
5608	12 x 2 Dexter (After 1997 - A Series Only) & 12 x 2 Dexter 7K (After 1997 - A Series Only)	Clam Shell
6604/5604	10 x 2 1/4 AL-KO	Clam Shell
6605/5605	12 x 2 AL-KO*	Clam Shell

Shoe and Lining Kits (Wheel Set)

Part No.	Description	Packaging
5000-DX	12 x 2 Dexter 12 x 2 Fayette (Bonded Shoes) 12 x 2 Aimco 12 x 2 Foreman	Boxed
5002	7 x 1 1/4 Dexter	Boxed
5003	10 x 2 1/4 Dexter	Boxed
5009	10 x 1 1/2 Dexter	Boxed
5010	12 x 2 Dexter 7K	Boxed
6004	10 x 2 1/4 AL-KO 10 x 2 1/4 Hayes	Boxed
6005	12 x 2 AL-KO	Boxed

* (Replace in pairs)



Bearing Set (L44610 Cup L44649 Cone)

Part No.	Description	Packaging
5502	7 1/4 x 1 1/4 Hayes (In & Out)	Clam Shell
	7 1/4 x 1 1/4 Foreman (In & Out)	
	7 x 1 1/4 Dexter BTL (In & Out)	
	7 x 1 1/4 Dexter BTR (In & Out)	
	7 1/4 x 1 1/4 Fayette (In & Out)	
	7 1/4 x 1 1/4 Foreman (In & Out)	
	10 x 1 5/8 Hayes (Out)	
	10 x 1 1/2 Dexter (Out)	
	10 x 2 1/4 AL-KO (Out)	
	10 x 2 1/4 Hayes (Out)	
	10 x 2 1/4 Dexter (Out)	
10 x 2 1/4 Fayette (Out)		
10 x 2 1/4 Foreman (Out)		

Bearing Set (25520 Cup 25580 Cone)

Part No.	Description	Packaging
5503	12 x 2 AL-KO (In)	Clam Shell
	12 x 2 Hayes (In) & 12 x 2 Hayes Centerline (In)	
	12 x 2 Dexter (In) & 12 x 2 Dexter 7K (In)	
	12 x 2 Fayette (In)	
	12 x 2 Foreman (In)	
	12 x 2 AL-KO (In) 6 & 8 Hole	

Bearing Set (L68111 Cup L68149 Cone)

Part No.	Description	Packaging
5505	10 x 2 1/4 AL-KO (In)	Clam Shell
	10 x 2 1/4 Fayette (In) (After 1972)	
	10 x 2 1/4 Hayes (In) (After 1972)	
	10 x 2 1/4 Dexter (In) (After Dec. 1983)	
	12 x 2 Foreman (In)	
	12 x 2 AL-KO (In) 6 & 8 Hole	

Bearing Set (LM48510 Cup LM48548 Cone)

Part No.	Description	Packaging
5506	10 x 2 1/4 Dexter (In) (Prior Dec. 1983)	Clam Shell
	10 x 2 1/4 Foreman (In)	
	10 x 2 1/4 Fayette (In) (Prior 1972)	

Bearing Set (L44610 Cup L44649 Cone)

Part No.	Description	Packaging
5507	10 x 1 5/8 Hayes (In)	Clam Shell
	10 x 1 1/2 Dexter (In)	
	12 x 2 Hayes (Out) & 12 x 2 Hayes Centerline (Out)	
	12 x 2 Dexter (Out)	
	12 x 2 Fayette (Out)	
	12 x 2 Foreman (Out)	

Bearing Set (14276 Cup 14125A Cone)

Part No.	Description	Packaging
5508	12 x 2 Dexter 6K & 7K 865 Hub (Out)	Clam Shell
	12 x 2 AL-KO 8 Hole 865 Hub (Out)	

Bearing Set (15245 Cup 15123 Cone)

Part No.	Description	Packaging
5509	12 x 2 Dexter 6K & 7K UTG Hub (Out)	Clam Shell
	12 x 2 AL-KO 6 & 8 Hole (865 Small)	

Return Spring Set (Axle Set)

Part No.	Description	Packaging
5304	10 x 2 1/4 AL-KO	Clam Shell
	10 x 1 5/8 Hayes	
	10 x 2 1/4 Hayes (Single Retractor)	
	10 x 2 1/4 Fayette	
5305	10 x 2 1/4 Hayes (Dual Retractor - Prior to May 1977)	Clam Shell
	10 x 2 1/4 Dexter	
	10 x 2 1/4 Aimco	
	10 x 2 1/4 Foreman	
	12 x 2 Aimco	
	12 x 2 Dexter (Dual Retractor) & 12 x 2 Dexter 7K	
5306	10 x 1 1/2 Dexter	Clam Shell
	12 x 2 AL-KO	
5307	12 x 2 Hayes	Clam Shell
	12 x 2 Dexter (Single Retractor)	
	12 x 2 Fayette	
	12 x 2 Fayette	

Hardware Kit (Axle Set)

Part No.	Description	Packaging
5320	7 x 1 1/4 Dexter	Clam Shell

Hold Down Kit (Axle Set)

Part No.	Description	Packaging
5353	10 x 2 1/4 AL-KO	Clam Shell
	10 x 2 1/4 Hayes	
	10 x 2 1/4 Dexter	
	10 x 2 1/4 Fayette	
	10 x 2 1/4 Aimco	
	12 x 2 AL-KO	
	12 x 2 Hayes & 12 x 2 Hayes Centerline	
	12 x 2 Dexter & 12 x 2 Dexter 7K	
	12 x 2 Fayette	
	12 x 2 Fayette	

Adjusting Screw Kit (Spring & Screw Assembly)

Part No.	Description	Packaging
5404	10 x 2 1/4 AL-KO	Clam Shell
	10 x 1 5/8 Hayes	
	10 x 1 1/2 Dexter	
	10 x 2 1/4 Hayes	
	10 x 2 1/4 Dexter	
	10 x 2 1/4 Fayette	
	10 x 2 1/4 Aimco	
	12 x 2 AL-KO	
	12 x 2 Hayes & 12 x 2 Hayes Centerline	
	12 x 2 Dexter & 12 x 2 Dexter 7K	
	12 x 2 Fayette	
	12 x 2 Aimco	
	12 x 2 Foreman	
	12 x 2 Foreman	

Adjusting Screw Spring Set (Not Pictured)

Part No.	Description	Packaging
5407	10 x 1 5/8 Hayes	Clam Shell
	10 x 1 1/2 Dexter	
	10 x 2 1/4 Hayes	
	10 x 2 1/4 Dexter	
	10 x 2 1/4 Fayette	
	10 x 2 1/4 Aimco	
	12 x 2 Hayes	
	12 x 2 Dexter	
	12 x 2 Fayette	
	12 x 2 Fayette	



WHEEL BEARING KITS

- Designed to fit most hubs used on boat, utility, snowmobile, and RV trailers
- Kit includes 2 bearing cones, 2 bearing cups, grease seal, and cotter pin

Part No.	Spindle Outer Diameter	Hub Diameter
WB100 0700	1"	1.980"
WB106 0700	1-1/16"	1.980"
WB138T0700*	1-3/8" x 1-1/16"	1.980"

Minimum order quantities may apply. *T applies to tapered axle applications.



BEARING PROTECTORS

- Protects wheel bearings from the elements during all trailer operations
- Automatically maintains the correct internal pressure – cannot damage seals
- Chrome-plated steel construction
- Sold in pairs and are available in bulk or full color display packages
- Some models include vinyl cover (see chart)

Part No.	Description	Hub Diameter	Packaging
BPC1780604*	Bearing Protector with Covers	1.781"	Clam Shell
BPC1980604*	Bearing Protector with Covers	1.980"	Clam Shell
BP232S0604	Bearing Protector	2.328"	Clam Shell
BP244S0604	Bearing Protector	2.441"	Clam Shell
BP198S0304	Bearing Protector	1.980"	Bulk
BP232S0304	Bearing Protector	2.328"	Bulk
BP244S0304	Bearing Protector	2.441"	Bulk
BB17810112*	Bearing Protector Covers - 2 pack	1.781"	Bag w/Header Card
BB19800112	Bearing Protector Cover - 2 pack	1.980"	Bag w/Header Card
BB24410112	Bearing Protector Cover - 2 pack	2.328" and 2.441"	Bag w/Header Card
BB19800312	Bearing Protector Cover	1.980"	Bulk
BB24410312	Bearing Protector Cover	2.328" and 2.441"	Bulk
000612	Bearing Protector	2"	Bulk

Minimum order quantities may apply.

*Bulk versions also available. Contact your sales representative.

GREASE CAPS



1500 Series

1600 Series

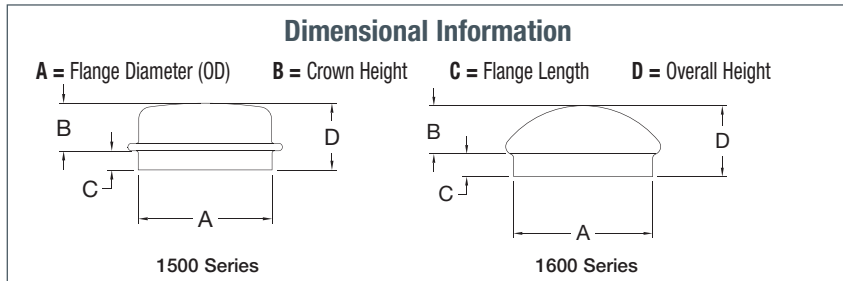

GREASE CAPS 1500 SERIES

Part No.	Mat. Gauge	Measurements (See Diagram)				Weight / 100 Pcs.
		A	B	C	D	
001501*	22	1.786"	0.63"	0.27"	0.89"	7.0 lbs.
-	22	1.786"	0.88"	0.28"	1.16"	7.3 lbs.
001503*	22	1.786"	1.16"	0.375"	1.535"	9.6 lbs.
001523	20	1.943"	0.69"	0.31"	1"	8.5 lbs.
001524	20	1.943"	1.04"	0.34"	1.38"	10.5 lbs.
001505*	22	1.968"	0.78"	0.375"	1.156"	9.5 lbs.
001521	20	1.988"	0.75"	0.220"	1.03"	10 lbs.
001520*	22	2.446"	1.03"	0.313"	1.34"	12.8 lbs.
001515*	20	2.567"	1.08"	0.281"	1.36"	15.0 lbs.
001526	20	2.722"	1.13"	0.312"	1.44"	15.6 lbs.
001531	16	3.155"	1.43"	0.37"	1.8"	46.0 lbs.
001528	20	3.358"	1.06"	0.56"	1.62"	26.8 lbs.

1600 SERIES

Part No.	Mat. Gauge	Measurements (See Diagram)				Weight / 100 Pcs.
		A	B	C	D	
100235*	16	2.333"	0.84"	0.37"	1.21"	15.4 lbs.
001601	16	2.333"	0.91"	0.37"	1.281"	18.0 lbs.
001604	16	2.446"	0.88"	0.28"	1.16"	18.8 lbs.
001606†	16	2.503"	0.53"	0.41"	0.94"	18.3 lbs.
001605	16	2.722"	1.03"	0.31"	1.34"	22.6 lbs.
001609	16	3.125"	1.01"	0.296"	1.31"	28.4 lbs.
001607	16	3.155"	1.16"	0.218"	1.375"	28.4 lbs.
001602	16	3.255"	0.61"	0.53"	1.145"	32.6 lbs.
001603	16	3.882"	0.44"	0.63"	1.07"	40.8 lbs.

All shown standards. *Zinc-plated for corrosion resistance. Minimum order quantities may apply.

† = Available while supplies last.



PLASTIC FENDERS

- High density polyethylene (HDPE) fenders
- Injection molded
- Corrosion proof
- Impact resistant, 300 lbs. capacity
- Molded-in color is "scratch proof"
- Built-in fender skirt
- Optional integral step pad
- Handles temperature extremes
- Mounting slots

Note: Lights not included.

Dimensional Information

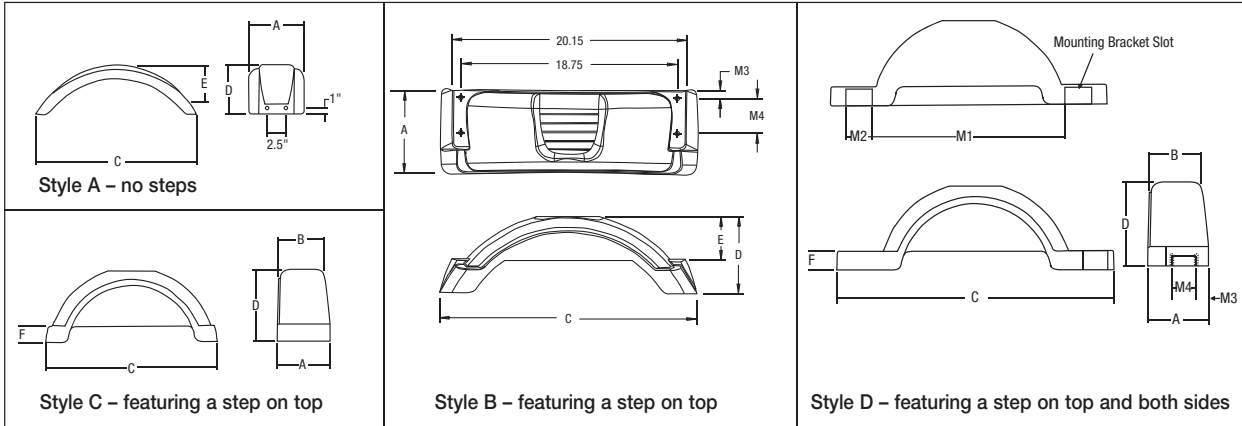

PLASTIC FENDERS

Style A

Part No. Bulk White	Part No. Bulk Black	Part No. Bulk Silver	Tire Size	Measurements (See Diagram)										Unit Wt. Lbs.
A	B	C	D	E	F	M (1)	M (2)	M (3)	M (4)					
008540*	008550*	—	8"-12"	7.00"	—	20.25"	6.25"	4.62"	—	—	—	2.25"	2.50"	1

Style B

Part No. Bulk White	Part No. Bulk Black	Part No. Bulk Silver	Tire Size	Measurements (See Diagram)										Unit Wt. Lbs.
A	B	C	D	E	F	M (1)	M (2)	M (3)	M (4)					
008549	008559	008569	8"-12"	7.35"	—	22.30"	6.50"	3.75"	2.18"	—	—	.075"	3.00"	1-1/4

Style C

Part No. Bulk White	Part No. Bulk Black	Part No. Bulk Silver	Tire Size	Measurements (See Diagram)										Unit Wt. Lbs.
A	B	C	D	E	F	M (1)	M (2)	M (3)	M (4)					
008541*	008551*	008561	8"-12"	7.35"	7.35"	21.80"	6.50"	3.75"	2.18"	—	—	2.43"	2.50"	1
008542	—	—	12"	7.51"	23.91"	8.77"	2.50"	—	2.75"	—	—	—	—	2
008543	008553	008563	13"	9.00"	7.70"	29.25"	12.00"	—	2.75"	—	—	—	—	3
—	008554	008564	14"	9.70"	8.00"	31.30"	12.75"	—	3.00"	—	—	—	—	3-3/4

Style D (US Patent D385, 512)

Part No. Bulk White	Part No. Bulk Black	Part No. Bulk Silver	Tire Size	Measurements (See Diagram)										Unit Wt. Lbs.
A	B	C	D	E	F	M (1)	M (2)	M (3)	M (4)					
008572	008582	008592	12"	7.50"	6.90"	33.50"	8.75"	—	2.50"	22.70"	4.00"	1.50"	3.00"	2-1/2
508572	—	—	12"	7.50"	6.90"	33.50"	8.75"	—	2.50"	22.70"	4.00"	1.50"	3.00"	2-1/2
008573	008583	008593	13"	9.00"	7.70"	40.00"	12.00"	—	2.75"	28.00"	4.00"	2.12"	3.75"	3-3/4
508573	—	—	13"	9.00"	7.70"	40.00"	12.00"	—	2.75"	28.00"	4.00"	2.12"	3.75"	3-3/4
008574	008584	008594	14"	9.70"	8.00"	43.40"	12.75"	—	3.00"	30.00"	4.00"	2.12"	3.75"	4-3/4
508574	—	—	14"	9.70"	8.00"	43.40"	12.75"	—	3.00"	30.00"	4.00"	2.12"	3.75"	4-3/4
008575	008585	008595	15"	10.25"	6.70"	45.00"	14.85"	—	3.00"	34.00"	4.00"	2.12"	3.75"	5-3/4

* Minimum order quantities may apply.



BOAT GUIDES

Boat guides help you visually guide your boat onto your trailer. High-strength super gripper mounting brackets attach firmly above and below the trailer frame. Easy bolt-on mounting fits trailer frames up to 3" x 5" high. Adjustable to provide optimum fit to any hull design.



BGR20

Part No.	Description	Upright Height
GB44 0101	Non-marring, marine grade PVC tubing, 1 pair	44"
GB150 0100	Non-marring, marine grade PVC tubing, 1 pair	50"
BGR20 0101	Steel construction with non-marring, cushioned rollers, 1 pair	20"

ACCESSORY PART

Part No.	Description
500358	Cap for BGR20 0101



GB150

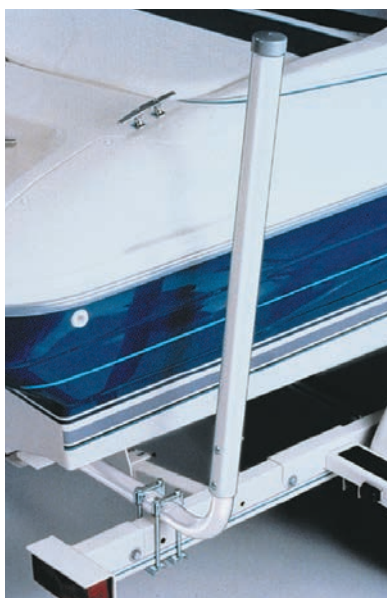

GB44



Replacement Bunk Carpeting

MARINE GRADE CARPETING

Marine Grade carpeting allows the do-it-yourselfer to replace worn and dirty carpet on bunk trailers. The carpet protects your boat investment by reducing scratching on the hull and keeps it in like-new condition. Individual rolls are shrink-wrapped for shelf display.

Part No.	Description
CR8008	Bunk carpeting, Black, 8" x 144"
CR8012	Bunk carpeting, Black, 12" x 144"



WaterWick

- Absorbs moisture from the air
- Helps control mold and mildew
- Contains 1.65 lbs/750 grams of Calcium Chloride (salt) that can absorb up to 1/4 gallon of moisture
- 32" long (with hook extended), 1.88 lbs.
- Designed for use in RVs, Trailers, Boats

Part No.	Description
1000750	WaterWick™

US Patent 6.273.942. B1

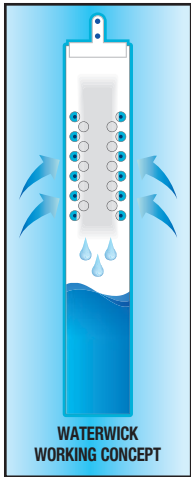

WATERWICK RECOMMENDED USAGE

Square Feet	Humidity	# of Units
Up to 30	Low	1-2
	High	2-3
Over 30	Low	2-3
	High	3-4

General guidelines only. Number of units needed may vary depending on your specific needs.

NOTE: Contains Calcium Chloride (salt). Possible adverse effects in case of contact with eyes.



7000100

WHEEL CHOCK

- Made from high impact polymer
- Reduces the risk of trailer roll
- Fits most trailer wheels
- Counter display box

Part No.	Description
7000100	Wheel Chock - must be ordered in multiples of 6 pairs



63300



HITCH & TRAILER ALIGNMENT TOOL

- Convenient one person hitch alignment system
- Magnetic base for fast and easy location
- Telescoping rods adjust up to 42"
- Easy to use the first time

Part No.	Description
63300	Hitch & Trailer Alignment Tool

SAFETY CHAINS



CHA0010340



CHA0040324

SAFETY CHAINS

- Safety chains are required by law in most states
- Cross chains when towing for added safety
- All chains conform to J684.6.3.4 SAE standards

Part No.	Grade	Size	Hook	Finish	Capacity	Description	Packaging
CHA0010140	30	1/4 x 24"	7/16" Safety Hook	Clear Zinc	5,000 lbs.	Proof coil chain. 1/4" chain interior dimension is sized so a 1/2" bolt shank can pass through. (2-pack)	Clam Shell
CHA0010340	30	1/4 x 24"	7/16" Safety Hook	Clear Zinc	5,000 lbs.	Proof coil chain. 1/4" chain interior dimension is sized so a 1/2" bolt shank can pass through.	Bulk
CHA0020324	70	1/4" x 36"	1/4" Forged Clevis Hook	Yellow Zinc	12,600 lbs.	Transport chain. 1/4" chain interior dimension is sized so a 1/2" bolt shank can pass through.	Bulk
CHA0030140	43	1/4 x 24"	7/16" Safety Hook	Clear Zinc	7,800 lbs.	Test chain. 1/4" chain interior dimension is sized so a 1/2" bolt shank can pass through. (2-pack)	Clam Shell
CHA0030340	43	1/4 x 24"	7/16" Safety Hook	Clear Zinc	7,800 lbs.	Test chain. 1/4" chain interior dimension is sized so a 1/2" bolt shank can pass through.	Bulk
CHA0040324	70	5/16" x 36"	5/16" Forged Clevis Hook	Yellow Zinc	18,800 lbs.	Transport chain.	Bulk
CHA0050324	70	5/16" x 42"	5/16" Forged Clevis Hook	Yellow Zinc	18,800 lbs.	Transport chain.	Bulk
CHA0060324	70	3/8" x 36"	3/8" Forged Clevis Hook	Yellow Zinc	26,400 lbs.	Transport chain.	Bulk
CHA0070324	70	1/2" x 42"	1/2" Forged Clevis Hook	Yellow Zinc	45,200 lbs.	Transport chain.	Bulk



63035



5592



49138



49137



40604



49147



34141



4234



1962

SAFETY CHAIN KIT

Part No.	Max GTW	Description
63034	2,000	6' Class I - S-Hooks on Both Ends (1pc)
63035	5,000	6' Class III - Quick Links on Both Ends (1pc)

SAFETY CHAIN KIT (BULK PACKAGED)

Part No.	Max GTW	Description
5592	3,500	6' Class II - 1/4" Proof Coil Chain.
2489	5,000	30" Class III - Straight Link Machine Chain

CLASS I-III CHAIN WITH S-HOOK, ONE END

Part No.	Description
49138	Class II GVWR 3,500 lbs. 24", 1/4" Proof Coil Grade 30, with S-Hook at One End (836)
49141	Class III GVWR 5,000 Lbs. 30", 1/4" Proof Coil Grade 30, with S-Hook at One End (839)

CLASS I-III SAFETY CHAIN WITH S-HOOK, BOTH ENDS

Part No.	Description
49137	Class I GVWR 2,000 Lbs. 48", 3/16" Proof Coil Grade 30, S-Hook, Both Ends (835)
44140	Class III GVWR 5,000 Lbs. 48", 1/4" Proof Coil Grade 30, S-Hook, Both Ends (839)

CLASS III SAFETY CHAIN WITH QUICK LINKS

Part No.	Description
40604	Class III 30" with Quick Links, Heavy Duty Safety Chain Kit for Tow Bars (5,000 lbs. GTW)

CLASS IV SAFETY CHAIN WITH CLEVIS HOOK

Part No.	Description
49148	Class IV 32", 5/16" Proof Coil Grade 30 5/16" Clevis Slip Hook, One End (7,600 lbs. GVW)
49149	Class IV 36", 1/2" proof Coil Grade 30 3/8" Clevis Slip Hook, One End (10,600 lbs. GVW)
49147	Class IV 35", 3/8" High Test 43 Clevis Slip & Latch Hook (16,200 lbs. GVW)

SAFETY CHAIN LOOPS

Part No.	Description
4234	2,000 lbs. Class I Safety Chain Loop
1962	5,000 lbs. Class II/III Safety Chain Loop
34141	10,000 lbs. Class IV Safety Chain Loop



FORGED D-RINGS, FORGED LASHING RINGS & BRACKETS



Part No.	Description	Work Load (lbs.)	Max Load (lbs.)
63024	Forged D Ring Yellow Zinc, 1/2" Forged D-Ring with Mounting Bracket, Measures 2-1/2" X 2-3/8" ID	4,000	12,000
63025	Forged Lashing Ring 18,000 lbs. 3/8" C1045 Material 5/8" Forged D-Ring with Weld Mounting Bracket	6,000	18,000
63026	Forged Lashing Ring 26,500 lbs. 3/8" Thick, C1045 Material 3/4" Forged D-Ring with Weld Mounting Bracket	8,833	26,500
63027	1" Forged D-Ring with Weld On Mounting Bracket, 3/8" Thick	15,587	46,760
63028	1x5x6 Forged Lashing Ring 46,760 lbs. C1045 Material 5/8" Forged D-Ring with Weld Mounting Bracket	15,587	46,760
44200	Recessed Rope Ring for 3/8" Plywood	400	1,200
44201	Rope Ring, Zinc 10 gauge	400	1,200
44202	Recessed Rope Ring & Trim Ring Zinc 16 gauge Steel for 1/4" Plywood	333	1,000

TOW HOOKS (BULK PACKAGED)



Part No.	Description	Max. GTW (lbs.)
63029	Tow Hook with Mounting Bolts (Chrome)	10,000
63030	Tow Hook with Mounting Bolts (Black)	10,000

S-HOOKS/J-CLIP FOR TRAILER SAFETY CHAIN

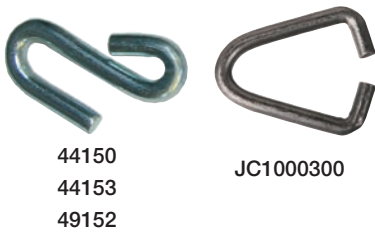

Part No.	Description
44150	S-hook for Trailer Safety Chain, Class I, Break Strength 2,000 lbs.
44153	S-hook for Trailer Safety Chain, Class II/III, Break Strength 5,000 lbs.
49152	S-hook for Trailer Safety Chain, Class IV, Break Strength 7,600 lbs.
JC1000300	J-Clip for Safety Chain

QUICK LINKS (BULK PACKAGED)

- Use to connect safety chains to tow vehicle or trailer



Part No.	Max GTW	Description
49132	3,500	1/4" Quick Link
49131	3,500	5/16" Quick Link
44133	3,500	3/8" Quick Link
49134	5,000	7/16" Quick Link
49135	10,000	1/2" Quick Link
74700	7,000	5/16" Quick-Link, Class III

CLEVIS SLIP HOOKS W/ LATCH FOR TRAILER SAFETY CHAIN



Part No.	Description
44154	Grade 43, Clevis Slip with Latch, 1/4"
44155	Grade 43, Clevis Slip with Latch, 5/16"
44156	Grade 43, Clevis Slip with Latch, 3/8"
44157	Grade 43, Clevis Slip with Latch, 1/2"
44163	Grade 70, Clevis Hook with Latch, 1/4"
44159	Grade 70, Clevis Hook with Latch, 5/16"
44164	Grade 70, Clevis Hook with Latch, 3/8"

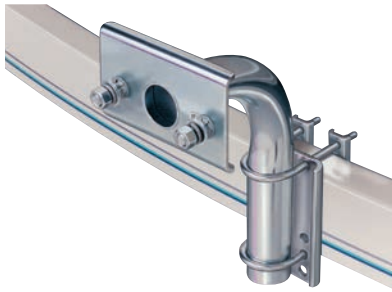

SPARE TIRE CARRIER

- Fits most 4, 5 and 6 lug wheels - up to 16-1/2"
- Provides 4-3/4" lift and over 7" of offset to mount tire up and out of the way
- Zinc-plated to resist corrosion
- Easy bolt-on installation, no cutting or drilling required
- Fits trailer tongue up to 3" wide by 5" high
- All mounting hardware and instructions included

Part No.	Description	Packaging
HDSTC 0101	Spare tire carrier	Bulk

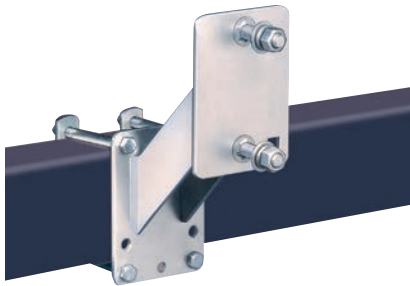

HI-MOUNT SPARE TIRE CARRIER

- Heavy-duty, welded and reinforced steel plate construction
- Zinc-plated to resist corrosion
- Adjustable bolt circle to fit both 4 and 5 lug wheels
- Fits all trailer tongues up to 3" wide by 4" high
- Includes zinc-plated mounting hardware and instructions
- Security locking hole to lock wheel and bracket to trailer using a security cable and lock (cable and lock sold separately).

Part No.	Description	Packaging
STC1000101	Hi-mount spare tire carrier	Ind. Box
STC1000301	Hi-mount spare tire carrier	Bulk

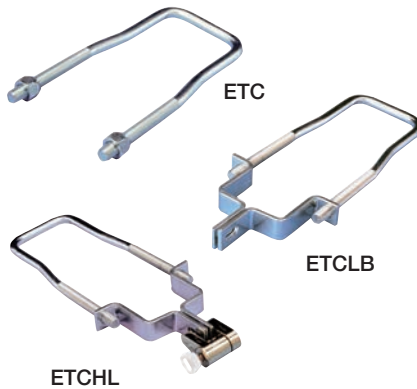

ECONOMY SPARE TIRE CARRIER

- Fits 8", 9", 12", 13", 14", and 15" wheels with 4 or 5 lug rims
- Easy to install
- Includes lug nuts to secure wheel to frame
- Heavy-duty 1/2" diameter construction
- Zinc-plated to resist corrosion

Part No.	Description	Packaging
ETC 0101	Economy spare tire carrier	Clam Shell
ETCLB 0700	Economy spare tire carrier with locking levers	Clam Shell
ETCHL 0700	Economy spare tire carrier with locking levers and HLO lock	Clam Shell



ECONOMY ETC & SPARE TIRE LOCK

- Tested tough
- Theft-resistant locking cap
- Fits over wheel studs (up to 9/16" diameter) to deter spare tire theft
- Removable plug allows longer wheel studs to protrude through cap
- Locking tab provides positive locking feature to prevent lock from turning

Part No.	Description	Packaging
ETCSTL0701	Economy spare tire carrier with STL spare tire lock	Clam Shell
STL 0603	Spare tire lock	Box



OUTBOARD MOTOR LOCK

- Heavy-duty barrel key lock mechanism for maximum security
- Foam filler insert reduces noise and vibration
- Mounts on most outboard motors

Part No.	Description	Packaging
OML 0127	Outboard motor lock	Clam Shell



40604

5,000 LBS. ADJUSTABLE TOW BARS

- Light-weight, only 31 lbs.
- Arms adjust from 26" to 41" for universal fit
- Tow bar mounting brackets bolt securely to vehicle bumper - (almost all applications will require a custom fabricated bracket due to bumper design)
- Heavy-Duty quick latch A-Frame coupler fits 2" ball
- Tow bar comes assembled, complete with installation instructions
- Some states require the use of double safety chains
- Black powder coat finish



40602

Part No.	Description
63180	Adjustable Tow Bar, 5,000 lbs. GVW, incl. mounting brackets
63181	Adjustable Tow Bar, 5,000 lbs. GVW, incl. mounting brackets w/Bolt together 2-piece adjustment arms
40604	Safety Chain Kit, Class III chains rated at 5,000 lbs. GTW
40602	Replacement Bumper Bracket Kit (Qty 2)
2471	Wire Lock Pin

NOTE: Total weight of towed vehicle must not exceed 5,000 lbs., or must not exceed the weight of the towing vehicle.



63180



63181

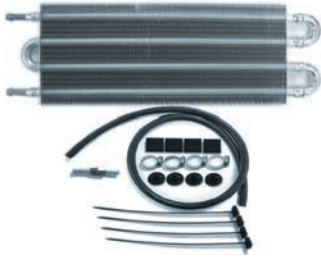

TUBE AND FIN TRANSMISSION COOLERS

- Ultrasonically soldered for reliability
- 100% pressure tested at 150 psi for quality assurance
- High efficiency turbulators for maximum heat dissipation
- 3/8" push-on fittings for quick and easy installation

Part No.	Towing Class	Application	Thickness	Width	Length
41010†	Light duty	Compact to mid-size cars (light duty)	3/4"	5"	12-3/4"
41011	Medium duty	Full-Size cars, mini-vans & SUVs towing up to 2,500 lbs. (med. duty)	3/4"	7-1/2"	12-3/4"
41013	Heavy duty	SUVs, vans and pick-up trucks, towing up to 5,000 lbs.	3/4"	7-1/2"	15-1/2"
41014	X-heavy duty	Pick-up trucks and motorhomes, towing over 5,000 lbs.	3/4"	10"	15-1/2"



PLATE AND FIN TRANSMISSION COOLERS

- Durable brazed aluminum construction
- Easy to install - simple instructions included
- 33% smaller than comparable tube and fin designs

Part No.	Towing Class	Application	Thickness	Width	Length
41019†	Class I	Compact to mid-size cars towing under 2000 lbs.	3/4"	4"	11"
41020	Class II	Full-size cars, mini-vans & SUVs towing 2,000-3,500 lbs.	3/4"	5-3/4"	11"
41310	Class III	SUVs, vans and pick-up trucks towing 3,500-5,000 lbs.	3/4"	7-1/4"	11"
41311	Class III	Pick-up trucks and motorhomes, towing over 5,000 lbs.	3/4"	12"	11"
41312	Class V	Pick-up trucks towing fifth wheels and gooseneck trailers	1-1/2"	11"	11"



3132

TRANSMISSION COOLER ACCESSORIES

Part No.	Description
3132	Transmission Oil Cooler Hose, 1-1/32" i.d., 25' long
41103†	Metal Strap Mounting Kit
41405	Nylon Tie Mount Kit (4 per bag)



41103†



41405

OEM CUSTOM FITTING KITS

Part No.	Description
41412	1987 and newer Jeep adapter kit for 5/8"-18, 45° S.A.E. flare
41410†	1983 and newer Ford, Lincoln & Mercury cars adapter kit for duckbill style line fittings
41415†	1983 and newer Ford, Lincoln & Mercury Cars and Ford trucks & vans, adapter kit for deep-thread style
41416†	1999 and later Dodge Trucks Adapter Kit for 9/16"-18 JIC 37° Flare
41418†	1996-up GMC snap-in transmission cooler fitting



41412



41410†



41415†



41416†



41418†

† = Available while supplies last.

DRAW-TITE® PROUD SPONSOR OF BRAD KESELOWSKI RACING



MERCHANDISING

PRODUCT DISPLAYS

Trailer Hitch Displays.	2
Weight Distribution Displays.	3
Fifth Wheel Hitch Displays.	4
Pin Box Displays.	5
Goosebox™ Displays.	5
Gooseneck Hitch Displays.	6
Electric Winch Display.	6
Velocity Series™ Jack Display.	6
Marine Jack Displays.	7
RV Jack Displays.	7
Brake Control Displays.	8
Mini Light Display.	8
Roof Rack Display.	8
Bike / Cargo Carrier Displays.	8
Gondola Displays.	9
Out Of Stock Displays.	9

MARKETING MATERIAL

Gondola Wallpaper.	9
Header Cards.	10
Showroom Signs	10
Counter Mats.	11
Window Clings.	11
Pennants.	11
Banners.	12
Outdoor Signs.	12
Product Catalogs.	13
Clip Art Disks.	13
Product DVDs.	13

MKG0221

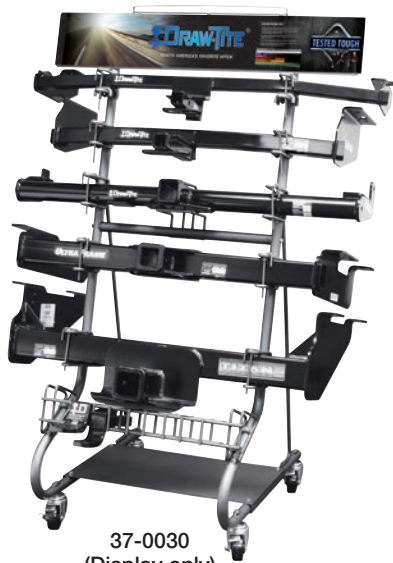

37-0030
(Display only)

HITCH DISPLAYS

Hitch Display Racks promote the products you install. Turn your hitch display into an add-on sales tool by attaching the Accessory Display Kit. It is designed to help promote the sale of hitch balls, tow vehicle wiring and other towing accessories.

*PRODUCT MUST BE ORDERED SEPARATELY - CASTERS NOT INCLUDED**

Part No.	Description
37-0030	5-Hitch, 4-Ball Mount Display w/Flip Chart Attachment
37-5638†	4-Hitch Display
MKG0221†	Draw-Tite® Flip Chart for Hitch Display 37-0030
MKG0218	Draw-Tite® logo sign (41-1/2" x 10")

Note: See HEADER CARDS / SIGNS for hitch display graphics.



MKG0221†



MKG0218

SUGGESTED PRODUCTS

Display Part No.	Brand/ Description	Parts to Order
37-0030	Draw-Tite®	24899, 36423, 75193, 41946, 45519



VIDEO LIBRARY

Need help with an installation? This collection of training sessions provides you information and a step-by-step guide on how to properly install our line of products.

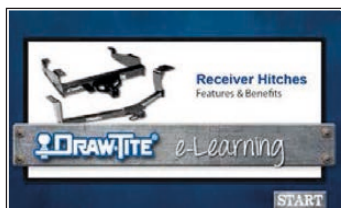

* **NOTE:** Casters may not be included with these displays, but will accept 3", 4" or 5" casters, with coarse thread 1/2" wide stem.

There may be charges for display items. Contact your sales representative for ordering information.

† = Available while supplies last.

WEIGHT DISTRIBUTING DISPLAYS

Great for showroom display of weight-distributing hitches.

*PRODUCT MUST BE ORDERED SEPARATELY - CASTERS ARE NOT INCLUDED**



37-2109
(Display only)

Part No.	Description
37-2109	Weight Distributing Stand (2-5/16" coupler) – 2" receiver tube built-in (2-5/16" ball not included)
MKG0629	Reese® SC Display Signage for 37-2109 (includes sign attachment brackets, brochure pocket) (French)
MKG0995	Reese® SC Display Signage for 37-2109 (includes sign attachment brackets, brochure pocket)
MKG1281	Reese® Weight Distribution/Sway Control Display Signage for 37-2109 (includes sign attachment brackets, brochure pocket)



37-2109 &
MKG0995



MKG0995



MKG0629



MKG1281

SUGGESTED PRODUCTS

Display Part No.	Brand/ Description	Parts to Order
37-2109	Reese® Trunnion WD	66540 or 66541 or 66542, 63835
	Reese® Round Bar WD	65509 or 67509 or 61009, 63835
	Reese® SC	66151 or 66153 or 66155 or 66157, 63835
	Reese® Dual Cam	26002
	Reese® Friction Sway Control	26660
	Reese® Strait Line® Trunnion	66082 or 66083 or 66084, 63835
	Reese® Strait Line® Round Bar	66086 or 66087 or 66088, 63835



VIDEO LIBRARY

Need help with an installation? This collection of training sessions provides you information and a step-by-step guide on how to properly install our line of products.



* **NOTE:** Casters are not included with these displays, but will accept 3", 4" or 5" casters, with coarse thread 1/2" wide stem.

There may be charges for display items. Contact your sales representative for ordering information.



37-2103

FIFTH WHEEL DISPLAYS

Fifth wheel hitch displays promote the products you install. Stand will display one fifth wheel hitch and rail kit. 37-2103 adjusts from 38" to 42" in width and includes signage posts.

*PRODUCT MUST BE ORDERED SEPARATELY - CASTERS ARE NOT INCLUDED**

Part No.	Description
37-2103	Heavy Duty Fifth Wheel Hitch Display with bolt-on signage posts (order signage separately)
MKG0346	Reese® logo sign (41-1/2" x 10")
MKG0466	Reese® Titan® 16K/20K merchandising sign for 37-2103
MKG0255	Reese® Elite™ Series merchandising sign for 37-2103



MKG0466



MKG0346

SUGGESTED PRODUCTS

Display Part No.	Brand/ Description	Parts to Order
	Reese® Elite™ Fifth Wheel	30142 or 30143
	Reese® Elite™ Fifth Wheel w/Slider	30144
	Reese® Fifth Wheel	30047 or 30033 or 30081 or 30083 or 30084
	Reese® Titan® 16K or 20K Fifth Wheel	30866 or 30867
	Reese® Elite™ 26.5K Fifth Wheel	30871
Rails and Mounting Bracket Required for Mounting Hitch to Display Description		
	Reese® Elite™ Fifth Wheel Rail	30126 (Ford) or 30868 (GM)
	Fifth Wheel Rails and Brackets	30035 and 50081
	Reese® Outboard Rails	30153



MKG0255

MKG0346

37-2103



VIDEO LIBRARY

Need help with an installation? This collection of training sessions provides you information and a step-by-step guide on how to properly install our line of products.



* **NOTE:** Casters may not be included with these displays, but will accept 3", 4" or 5" casters, with coarse thread 1/2" wide stem.

There may be charges for display items. Contact your sales representative for ordering information.

PIN BOX DISPLAYS

Fifth wheel trailer pin box displays promote the pin boxes you install. Stand will display one of the custom pin boxes. Reese 16K head, signage and brochures are included with display.

*PRODUCT MUST BE ORDERED SEPARATELY - CASTERS NOT INCLUDED**

Part No.	Description
37-2130	Reese® Pin Box Display (includes Reese 16K head, signage and brochures)

**NOTE: Casters may not be included with these displays, but will accept 3," 4" or 5" casters, with coarse thread 1/2" wide stem.*



Shown with Sidewinder™

37-2130
INCLUDES: Signage, Brochures



Shown with 5th Airborne™

37-2130
INCLUDES: Signage, Brochures



Shown with Elite Airborne/Sidewinder™

37-2130
INCLUDES: Signage, Brochures

SUGGESTED PRODUCTS

Display Part No.	Brand/ Description	Parts to Order
37-2130*	Reese®	61420 (Sidewinder™)
	Reese®	5AB-E1621-16K (5th Airborne™)
	Reese® Elite™	61422 (Airborne/Sidewinder™ Combo)

**NOTE: Includes signage and brochures.*

GOOSE BOX™ & PIN BOX DISPLAY STAND

Fifth wheel trailer pin box displays promote the pin boxes you install. Stand will display one of the custom pin boxes. Reese 16K head, signage and brochures are included with display.

*PRODUCT MUST BE ORDERED SEPARATELY - CASTERS NOT INCLUDED**

Part No.	Description
MKG1780	Reese® Goose Box & Pin Box Display Stand
MKG1778	Reese Goose Box Display Sign - ONLY FOR USE w/MKG1780 stand
MKG1779	Reese Pin Box Display Sign - ONLY FOR USE w/MKG1780 stand
MKG1781	Literature Holder-ONLY FOR USE w/MKG1780 Goose Box/Pin Box Display Stand (order 1 for each sign/side)
MKG0275	Reese Advanced Fifth Wheel Pin Box Brochure
MKG0656	Reese Goose Box Brochure

**NOTE: Casters may not be included with these displays, but will accept 3," 4" or 5" casters, with coarse thread 1/2" wide stem.*



MKG1780

MKG1778



MKG1779



There may be charges for display items. Contact your sales representative for ordering information.



37-2118
Draw-Tite®

INCLUDES: Signage, Brochures

GOOSENECK HITCH DISPLAYS

Gooseneck displays promote the gooseneck trailer towing systems you install. Stand will display hitch system and platform heads.

PRODUCT MUST BE ORDERED SEPARATELY - NOT CASTER READY

Part No.	Description
37-2118*	Draw-Tite® Hide-A-Goose™ System Display (includes signage and brochures)
116437	Draw-Tite® Signage
116448	Display Stand Assembly

**NOTE: Displays Under-Bed Gooseneck, Remov-A-Ball® and Fold-Down Gooseneck Hitches*

SUGGESTED PRODUCTS

Display Part No.	Brand/ Description	Parts to Order
37-2118*	Draw-Tite®	6300, 8339, 9460-48

**NOTE: Includes signage and brochures.*



37-3016

ELECTRIC WINCH DISPLAY

Display stands increase end-user visibility to Electric Winches. Using a minimal amount of floor space these stands provide easy access to customers.

PRODUCT MUST BE ORDERED SEPARATELY - NOT CASTER READY

Part No.	Description
37-3016	BULLDOG® Electric Winch Display
37-2075	BULLDOG® Electric Winch Aluminum Sign



37-2075



VELOCITY SERIES™ JACK DISPLAY STAND

Display stands increase end-user visibility to Velocity Series™ Jacks.

Stand will display jack and remote.

PRODUCT MUST BE ORDERED SEPARATELY - NOT CASTER READY

Part No.	Description
MKG2097	BULLDOG® Velocity Series™ Display Signage
37-0023	BULLDOG® Velocity Series™ Display Stand



MKG2097



37-0023 (stand only)

There may be charges for display items. Contact your sales representative for ordering information.

MARINE JACK DISPLAYS

Display stands increase end-user visibility to Jacks and Winches. Using a minimal amount of floor space these stands provide easy access to customers.

PRODUCT MUST BE ORDERED SEPARATELY - NOT CASTER READY



37-2125†
 INCLUDES: Marine Jack Adaptors & Fold-Away Bolt-on Hinge Kit

Part No.	Description
37-2125†	Display Stand – Marine Jacks, Includes(3) Jack Display Adaptors #117399, (1) Fold-Away™ Bolt-on Hinge Kit
117398	Jack Display Stand Only
117399	Marine Jack Display End Caps – Jack Adapter Only

SUGGESTED PRODUCTS

Display Part No.	Brand/ Description	Parts to Order
37-2125†	Fulton® Jacks (4)	XP10 0101, XPD15L0101, 1413040134, 141133
	Fulton® F2™ Winch (1)	FW16000101
	Fulton® Fold-Away Hinge Kit	Included with display: HDPB330101

RV JACK DISPLAYS

Display stands increase end-user visibility to A-frame Jacks. Using a minimal amount of floor space these stands provide easy access to a variety of jacks.

PRODUCT MUST BE ORDERED SEPARATELY - NOT CASTER READY



37-2126†
 INCLUDES: A-Frame Jack Adaptors

Part No.	Description
600051	Display Stand – Jacks, Includes: Integrated Center A-Frame Mount, (4) A-Frame Jack Display Adaptors
37-2126	Display Stand – RV Jacks, Includes (4) Jack Display Adaptors #117400
37-2134	A-Frame Jack Mount System for Lozier Gondola - includes (1) 37-2131 Crossbar, (5) 37-2132 Brackets, (1) 37-2133 Bracket Support
117398	Jack Display Stand Only
117400	RV Jack Display End Caps – Jack Adapter Only

SUGGESTED PRODUCTS

Display Part No.	Brand/ Description	Parts to Order
37-2126	BULLDOG® Manual Jacks (4)	1551570117, 1550220117, 1550320117, 1750290317
	Pro Series™ Manual Jacks (4)	EA20000103, RV20000103, 1400600303, EA20000340
Rails and Mounting Bracket Required for Mounting Hitch to Display Description		
600051	BULLDOG® Electric Jack (1)	500185 or 500186 or 500187 or 500188
	BULLDOG® Manual Jacks (4)	1551570117, 1550220117, 1550320117, 1750290317
	Pro Series™ Electric Jack (1)	500198
	Pro Series™ Manual Jacks (4)	EA20000103, RV20000103, 1400600303, EA20000340



600051
 INCLUDES: A-Frame Mount Adaptors



37-2134
 For 4' gondola displays

There may be charges for display items. Contact your sales representative for ordering information.

† = Available while supplies last.



MKG2358
(Display only)

COUNTER TOP BRAKE CONTROL DISPLAYS

Counter top brake control displays with interchangeable insert cards. Cards are easily removed to change display as often as needed. Insert cards sold separately. *PRODUCT MUST BE ORDERED SEPARATELY*

Part No.	Description
37-2110†	Brake Control Counter Top Display Only
37-2115†	Draw-Tite® Brake Control Counter Top Display w/Activator® III Graphic Package
37-2116†	Reese® Brake Control Counter Top Display w/Brakeman® Ultra Graphic Package
MKG0916	Draw-Tite® Brake Control Display Decal Set for 37-2110
MKG0917	Tekonsha® Brake Control Display Decal Set for 37-2110
MKG0918	Reese® Brake Control Display Decal Set for 37-2110
MKG0919	Pro Series™ Brake Control Display Decal Set for 37-2110
MKG2358	Tekonsha® ZCI™ Display



37-2048†

37-2049†

MINI LIGHT DISPLAY

Light display mounts to gondola using peg hooks. Includes incandescent and LED tail lights, clearance lights, and AMP meter to show the draw of each type of light. No internal power source, includes 6' wiring for battery use. 20" L x 9" H x 5" D.

Part No.	Description
37-2048†	Bargman® Mini Light Display includes Lights & AMP Meter
37-2049†	Wesbar® Mini Light Display includes Lights and AMP Meter



37-2135

ROOF RACK DISPLAY

Attach the signage and this unit makes an engaging countertop display. Versatile tool! For a vertical display, the base unit is easily mounted on standard slat wall material. Simply attach two included brackets to the lower unit and slip into your slat wall. Shows five varieties of mounting feet: APE, APX, GTX REX and the universal fit RBU. 29.5" x 15.5" x 23.5"

Part No.	Description
37-2135	Roof Rack Display



37-2046

37-6475†

37-6297

PRODUCT MUST BE ORDERED SEPARATELY

BIKE / CARGO CARRIER DISPLAYS

Hitches aren't just for towing any longer. From bike and cargo carriers to the wide range of front mounted receiver accessories, these displays illustrate all the options available to your customer with the purchase of their new receiver. Load up the carriers in your showroom to illustrate the features and benefits of these great hitch mounted accessories.

PRODUCT MUST BE ORDERED SEPARATELY

Part No.	Description
37-2046	4-Bike Carrier Display
37-6297	2-Cargo/Bike Carrier Display (Bottom half)
37-6475 †	Roof Top Carrier Display for use with 37-6297 (Top half)
37-6299	Adventure System Display (with counterweight)

There may be charges for display items. Contact your sales representative for ordering information.

† = Available while supplies last.

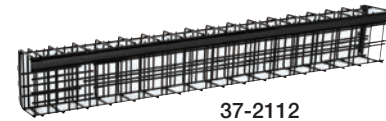

37-2112



37-2127



37-2114



37-2134

GONDOLA DISPLAY ACCESSORIES

Gondola display accessories offer your customers a complete line of towing and vehicle accessories.

PRODUCT MUST BE ORDERED SEPARATELY

Part No.	Description
37-2112	Rack 4' - Ball Mount for Lozier Gondola
37-2114	Rack 4' - Hitch Ball for Lozier Gondola
37-2127	Rack 4' - One Half Hitch Ball / One Half Ball Mount for Lozier Gondola
37-2131	Crossbar 4' for Lozier Gondola (mount up to 5 brackets, 37-2132)
37-2132	Bracket (each) - A-Frame Jack Mounting on 37-2131 Crossbar (mount up to 3 jacks / ea bracket)
37-2133	Bracket Support 4' (each) - A-Frame Jack Mounting on 37-2131 Crossbar (use w/37-2132)
37-2134	A-Frame Jack Mount System for Lozier Gondola - includes (1) 37-2131 Crossbar, (5) 37-2132 Brackets, (1) 37-2133 Bracket Support

DISPLAY – OUT OF STOCK TAGS

Part No.	Description
MKG0269	Draw-Tite® “Out of Stock” Tags, 50 pcs.
MKG0271	Reese® “Out of Stock” Tags, 50 pcs.

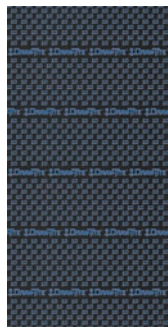

MKG0225



MKG0191



MKG0210

GONDOLA WALLPAPER

Ideal for drawing attention to gondolas displaying products. Wallpaper is 2'x4' and ideal for covering multiple colored pegboards on the display floor. Wallpaper is heavy-duty vinyl, pre-perforated for peg hooks and includes mounting pins to attached to peg board.

GONDOLA WALLPAPER, 2' X 4'

Part No.	Description
MKG0210	BULLDOG® Logo Design
MKG0225	Draw-Tite® Logo Design
MKG0191	Fulton® Logo Design

There may be charges for display items. Contact your sales representative for ordering information.



MKG0209



MKG0218



MKG0219



MKG0182



MKG0346



MKG0255



MKG0466

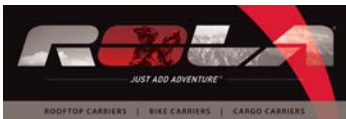

MKG0236 MKG0237

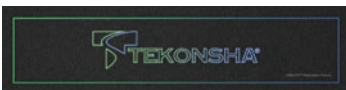

MKG0188 MKG0189

HEADER CARDS / SIGNS

Merchandising headers in a wide range of sizes for use on displays or any showroom application.

Part No.	Description	Size
MKG0209	BULLDOG® The Choice of America's Military & Manufacturers Merchandising Sign	14" x 48"
MKG0218	Draw-Tite® Logo Merchandising Sign	10" x 41-1/2"
MKG0219	Draw-Tite® Merchandising Sign	14" x 42"
MKG0182	Reese® Pioneering Performance Merchandising Sign	15" x 39"
MKG0205	Reese® Merchandising Sign	14" x 42"
MKG0255	Reese® Elite™ Series Fifth Wheel Hitches Merchandising Sign	20" x 41-1/2"
MKG0346	Reese® Logo Merchandising Sign	10" x 41-1/2"
MKG0466	Reese® Titan® Series Fifth Wheel Hitches Merchandising Sign	20" x 41-1/2"
MKG0236	ROLA® Merchandising Sign	14" x 42"
MKG0237	ROLA® Merchandising Sign	9" x 16"
MKG0239	ROLA® Cargo Basket/Adventure Merchandising Sign	9" x 34"
MKG0188	Tekonsha® Logo Merchandising Sign	6" x 24"
MKG0189	Tekonsha® Logo Merchandising Sign	6" x 48"

SHOWROOM SIGNS HOURS OF OPERATION

Part No.	Description
MKG0198	Reese® Hours of Operation Indoor Sign
MKG0216	Draw-Tite® Hours of Operation Indoor Sign
MKG0252	Hidden Hitch® Hours of Operation Indoor Sign

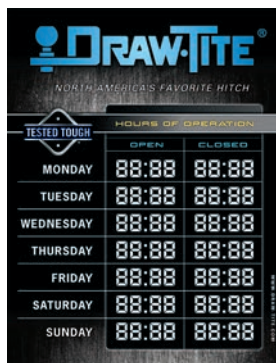

MKG0216

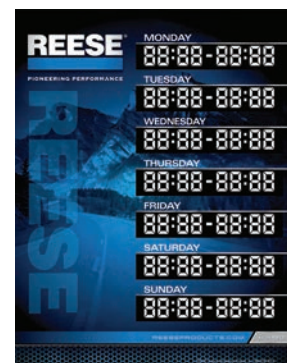

MKG0198

There may be charges for display items. Contact your sales representative for ordering information.



MKG0190



MKG0257



MKG1081



MKG0811†



MKG1549

COUNTER MATS

Part No.	Description
MKG0224	Draw-Tite® Gooseneck Hitch Systems
MKG0811†	Draw-Tite® / Tow Ready® America's Favorite Hitch
MKG0257	Powerful Brands Reese®, Tekonsha®, BULLDOG®
MKG0190	Tekonsha® Brake Controls
MKG1081	Reese® Weight Distribution / Fifth Wheel Systems
MKG1549	Fulton® Brent Chapman/Fulton Effect Counter Mats

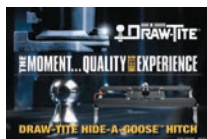

MKG0223



MKG1929

WINDOW CLINGS

Part No.	Description
MKG0223	Draw-Tite® Hide-A-Goose™ Hitch, 4" x 6", two sided
MKG1929	Draw-Tite® QSP Window Cling, 8" x 6", two sided

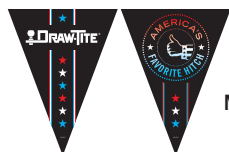

MKG0607

PENNANTS

Stringed pennant flags, 25 ft.

Part No.	Description
MKG0463	Draw-Tite® Tested Tough
MKG0607	Draw-Tite® America's Favorite Hitch
MKG0117	Fulton® 100 Years of Performance



MKG0117

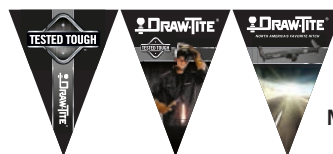

MKG0463

† = Available while supplies last.



MKG0196



MKG0202



MKG1276

BANNERS

Attract potential customs with branded durable, indoor/outdoor banners.

Part No.	Description
MKG0196	Draw-Tite® Tested Tough®, 5' x 3' w/four grommets
MKG0311	Fulton® 100 Year, 6' x 2' w/four grommets
MKG0202	Reese® Pioneering Performance, 5' x 3' w/four grommets
MKG0183†	Tow Ready®, 5' x 3' w/four grommets
MKG1276	BULLDOG® The Choice of America's Military & Manufacturers, 5' x 3'
MKG2090	Reese® We Sell, Secure Your Passion Banner, w/four grommets - French, 6' x 3'



MKG0311



MKG2090

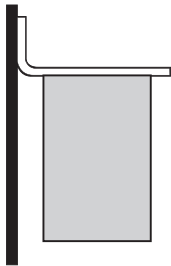

2859

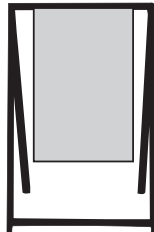

2860

OUTDOOR SIGNS

Outdoor metal signs with two different mounting systems. Purchase sign and mountings separately. Curbside A-Frame stand, with extra wide stance, folds for easy storage. Durable metal bracket for either wall or pole mounting includes hardware for installation.

Part No.	Description
2859	Wall or pole mounting bracket only
2860	Curbside stand only
2858	Draw-Tite® aluminum sign only, 24" w x 30" h
37-5652	Reese® aluminum sign only, 24" w x 30" h, two sided
37-2075	BULLDOG® Electric Winch aluminum sign
37-2027	Draw-Tite® aluminum sign



37-5652



2858



37-2027
(Available February 2017)



37-2075

There may be charges for display items. Contact your sales representative for ordering information.

† = Available while supplies last.

REESE® BUILT FOR LIFE



REPLACEMENT PARTS

WEIGHT DISTRIBUTION SYSTEMS

Reese® SC Weight Distributing.	2
Reese® Heavy Duty Trunnion Bar Weight Distributing.	3
Reese® Heavy Duty Round Bar Weight Distributing.	4
Reese® Steadi-Flex™ Light Duty Weight Distributing.	5
Reese® RB2 Weight Distributing.	6
Reese® Trunnion Bar Weight Distributing.	7

FIFTH WHEEL HITCHES

Reese® Elite™ 18K Fifth Wheel Hitch.	10
Reese® Elite™ 25K Fifth Wheel Hitch.	11
Reese® Elite™ 26.5K Fifth Wheel Hitch.	12
Reese® 16K Fifth Wheel Hitch.	13-14
Reese® 20K Fifth Wheel Hitch.	15-16
Reese® 22K Fifth Wheel Hitch.	17
Reese® Fifth Wheel Rail Kits.	18

SWAY CONTROL

Reese® Friction Sway Control.	8
Reese® Dual Cam HP Sway Control.	9



REESE SC WEIGHT DISTRIBUTING



Reese #'s: 66151†, 66153†, 66155†, 66156, 66157†

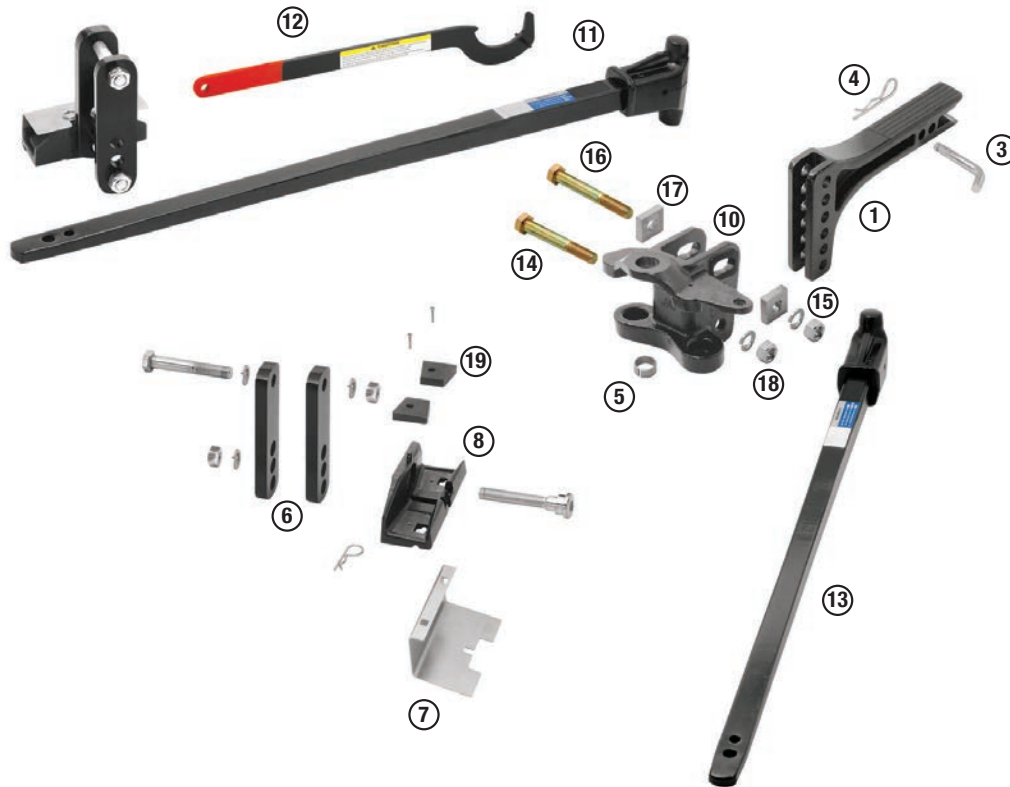

Ref.	Part No.	Qty.	Description
3	55010	1	Pull pin
4	55515	1	Spring clip
6	58518	1	600 lbs. & 800 lbs. Frame Bracket Assembly
	58519	1	1200 lbs. Frame Bracket Assembly
	58352	1	1500 lbs. Frame Bracket Assembly
7	58349	1	Cover for pad hanger
8	58350	1	Pad hanger
10	58167	1	Ball mount assembly
5		1	Reducer bushing 1-1/4" to 1"
16		1	HH cap screw (3/4"x 5.5")
17		2	Hex nuts (3/4")
18		2	Adjusting washers
14		1	HH cap screw (3/4" x 4.5")
15		2	Split lock washer (3/4")

Ref.	Part No.	Qty.	Description
1	54970	1	Adjustable hitch bar (12")
5	58184	1	Reducer bushing: 1-1/4" to 1"
12	58351	1	Lift handle for frame bracket
13	58356		600 lbs. spring bar
	58357		800 lbs. spring bar
	58358		1200 lbs. spring Bar
	58359		1500 lbs. spring bar
11	58098		600 & 800 lbs. trunnion & pin
11	58097		1200 & 1500 lbs. trunnion & pin
15	58133	2	Lock washers
16		1	HHC screw (3/4"x 5.5")
14		1	HHC screw (3/4"x 4.5")
17		2	Adj. serrated washers
18		2	Hex nuts
19	58512	1	Friction pads with screws
		2	Friction pads right side
		2	Friction pads left side
		4	Machine screws (M-6)

† = Available while supplies last.

HEAVY DUTY TRUNNION BAR WEIGHT DISTRIBUTING



Reese #'s: 66540, 66541, 66542, 66020, 66021, 66022, 66131, 66006



Ref.	Part No.	Qty.	Description
3	55010	1	Pull pin
4	55515	1	Spring clip
23	21501	1	Snap-up bracket
17		1	Set screw
24		1	Safety pin
	58392	1	Snap-up bracket w/set screw & safety pin (for use w/weight distribution systems w/tongue weight 800 lbs. and over)
3	66014	1	Pull pin
4		1	Spring clip
5		1	Reducer bushing 1-1/4" to 1"
17		2	Square head set screw (1/2"-13 x 3-1/2")
24		2	Safety pins
19		2	U-bolts (3/8" attaches chain to spring bar)
18		2	Chains: 11 link (8/0)
20		4	Lock nuts (3/8"-16)
21		4	Flat washers (3/8")
19	55630	1	U-bolts (3/8" attaches chain to spring bar)
18		1	Chains: 11 link (8/0)
20		2	Lock nuts (3/8"-16)
21		2	Flat washers (3/8")
33	58024	2	Replacement adjusting washers
24	55180	2	Safety pins (1 per Box)
17	58033	2	Square head bolt (1/2"-13 x 3-1/2")
19	58032	2	U-bolts (3/8" attaches chain to spring bar)
20		4	Lock nuts (3/8"-16)
21		4	Flat washers (3/8")

Ref.	Part No.	Qty.	Description
36	58167	1	Ball mount assembly (Reese only)
5		1	Reducer bushing 1-1/4" to 1"
31		1	HH cap screw (3/4"x 5.5")
32		2	Hex nuts (3/4")
33		2	Adjusting washers
34		1	HH cap screw (3/4" x 4.5")
35		2	Split lock washer (3/4")
1	54970	1	Adjustable hitch bar (12"), 1500 lb. rating
1	54977	1	Adjustable hitch bar for #66006, 15" 1700 lb. rating
5	58184	1	Reducer bushing: 1-1/4" to 1"
25	58162	1	Handle for snap-up bracket
	58369	1	1500 lbs. Spring bar & trunnion
30	23227	1	600 lbs. Spring bar & trunnion
	22225	1	800 lbs. Spring bar & trunnion
	66009	1	1200 lbs. Spring bar & trunnion
	66010	1	1700 lbs. Spring bar & trunnion
11	58097	1	1-3/8" trunnion & pin
11	58098	1	1-1/8" trunnion & pin
35	58133	2	Lock washers
31		1	HHC screw (3/4"x 5.5")
34		1	HHC screw (3/4"x 4.5")
33		2	Adj. serrated washers
32		2	Hex nuts
	58459	1	Threaded screw service kit, under mount couplers only
19	58032	2	U-bolts (3/8" attaches chain to spring bar)

HEAVY DUTY ROUND BAR WEIGHT DISTRIBUTING



Reese #'s: 65509, 67509, 61009



Ref.	Part No.	Qty.	Description
3	55010	1	Pull pin
4	55515	1	Spring clip
23	21501	1	Snap-up bracket
17		1	Set screw
24		1	Safety pin
	58392	1	Snap-up bracket w/set screw & safety pin (for use w/weight distribution systems w/tongue weight 800 lbs. and over)
3	66014	1	Pull pin
4		1	Spring clip
5		1	Reducer bushing 1-1/4" to 1"
17		2	Square head set screw (1/2"-13 x 3-1/2")
24		2	Safety pins
19		2	U-bolts (3/8" attaches chain to spring bar)
18		2	Chains: 11 link (8/0)
20		4	Lock nuts (3/8"-16)
21		4	Flat washers (3/8")
19	55630	1	U-bolts (3/8" attaches chain to spring bar)
18		1	Chains: 11 link (8/0)
20		2	Lock nuts (3/8"-16)
21		2	Flat washers (3/8")
24	55180	2	Safety pins (1 per Box)
19	58032	2	U-bolts (3/8" attaches chain to spring bar)
20		4	Lock nuts (3/8"-16)
21		4	Flat washers (3/8")

Ref.	Part No.	Qty.	Description
1	54970	1	Adjustable hitch bar (12")
5	58184	1	Reducer bushing 1-1/4" to 1"
25	58162	1	Handle for snap-up bracket
2	58112	1	Ball mount (Reese only)
5		1	Reducer bushing 1-1/4" to 1"
10		2	Split lock washers
6		2	HHC screws (3/4"-10 x 5")
9		2	Flat washers (3/4"-hardened)
7		2	Hex nuts (3/4"-10)
8		2	Adjustment washers
		1	Installation instructions
28	58114	1	800 lbs. Spring bar
	58115	1	1200 lbs. Spring bar

STEADI-FLEX™ LIGHT DUTY WEIGHT DISTRIBUTING

Reese #'s: 66557, 66558



STEADi-FLEX®

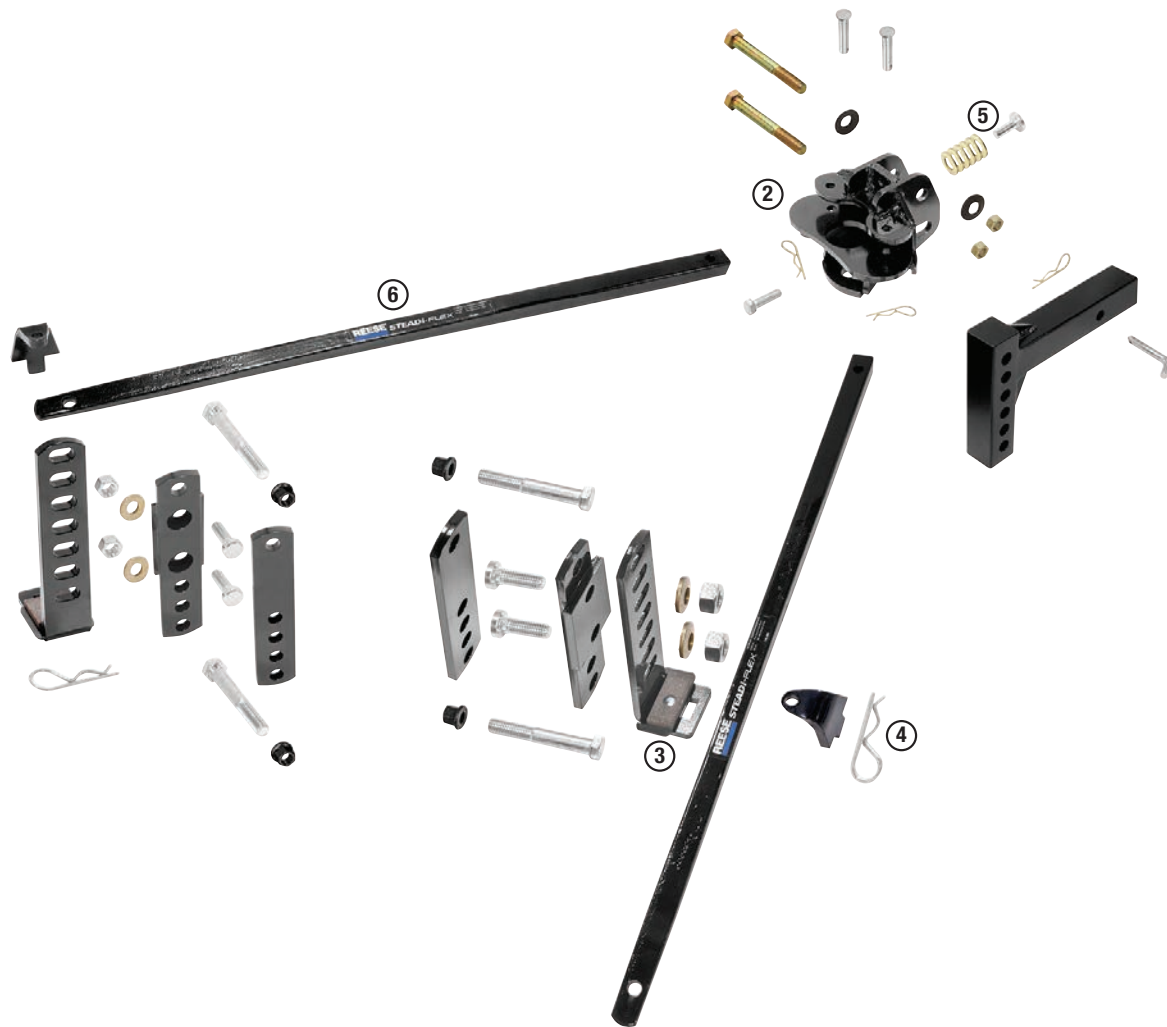

Ref.	Part No.	Qty.	Description
2	58513	1	Ball mount w/hardware
4	58497	2	Friction pads w/hardware
4	58498	1	Retention Bracket w/clip
5	58499	1	Ball mount adjustment washers and pin
6	58500	1	Spring bar w/pin and clip 400 LB
	58501	1	Spring bar w/pin and clip 600 LB

RB2 WEIGHT DISTRIBUTING



Reese #'s : 49568, 49569, 49570



Ref.	Part No.	Qty	Description
3	55010	1	Pull pin
4	55515	1	Spring clip
23	58362	1	Frame bracket assembly (snap-up)
17		1	Square head bolt (1/2"-13 x 3-1/2")
24		1	Safety pin
19	58364	1	U-bolt (3/8" attaches chain to spring bar)
18		1	Chain – 9 link (8/0)
20		2	Lock nuts (3/8"-16)
21		2	Flat washers (3/8")
24	55180	2	Safety pins (1 per Box)
1	54970	1	Adjustable hitch bar (12")

Ref.	Part No.	Qty	Description
5	55030	1	Reducer bushing 1-1/4" to 1"
25	58162	1	Handle for snap-up bracket
2	58333	1	Ball mount
5		1	Reducer bushing 1-1/4" to 1"
10		2	Split lock washers
6		2	HHC screws (3/4"-10 x 5")
9		2	Flat washers (3/4"-hardened)
7		2	Hex nuts (3/4"-10)
8		2	Adjustment washers
		1	Installation instructions
28	58336	1	600 lbs Spring bar
	58337	1	800 lbs. Spring bar
	58338	1	1200 lbs. Spring bar
5-10	58339	1	Hardware bag for ball mount



TRUNNION WEIGHT DISTRIBUTING

Reese #'s: 49585†, 49586†, 49587†

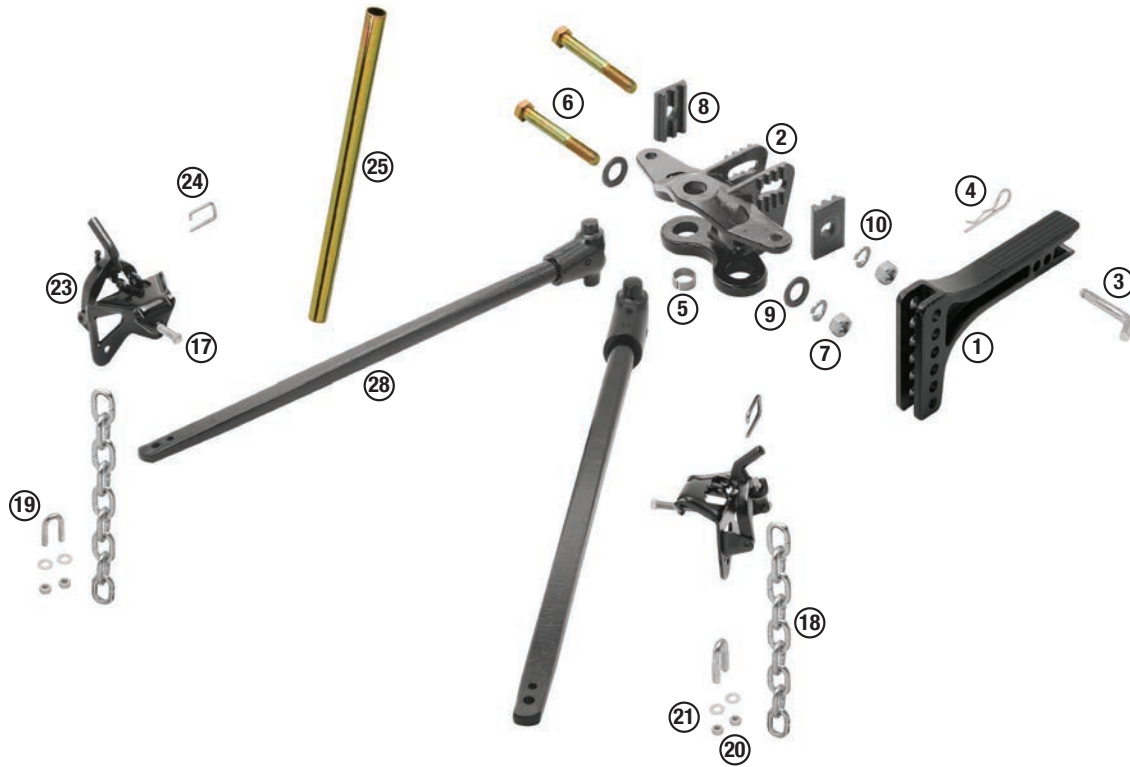

Ref.	Part No.	Qty.	Description
3	55010	1	Pull pin
4	55515	1	Spring clip
23	58362	1	Frame bracket assembly (snap-up)
17		1	Square head bolt (1/2"-13 x 3-1/2")
24		1	Safety pin
19	58364	1	U-bolt (3/8" attaches chain to spring bar)
18		1	Chain – 9 link (8/0)
20		2	Lock nuts (3/8"-16)
21		2	Flat washers (3/8")
24	55180	2	Safety pins (1 per Box)
1	54970	1	Adjustable hitch bar (12")

Ref.	Part No.	Qty.	Description
5	58184	1	Reducer bushing 1-1/4" to 1"
25	58162	1	Handle for snap-up bracket
2	58333	1	Ball mount
5		1	Reducer bushing 1-1/4" to 1"
10		2	Split lock washers
6		2	HHC screws (3/4"-10 x 5")
9		2	Flat washers (3/4"-hardened)
7		2	Hex nuts (3/4"-10)
8		2	Adjustment washers
		1	Installation instructions
28	58344	1	600 lbs Spring bar
	58345	1	800 lbs. Spring bar
	58346	1	1200 lbs. Spring bar
5-10	58339	1	Hardware bag for ball mount

FRICION SWAY CONTROL



Reese #: 26660†, 83660

③ (Spring Clip Only)



②

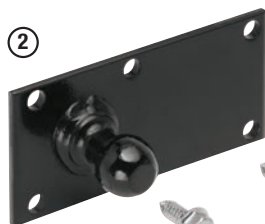

①



Ref.	Part No.	Qty.	Description
1	58060	1	Ball assembly (includes ball, washer, & nut)
2	58062	1	Ball plate & mounting screws
3	55515	2	Spring clip

† = Available while supplies last.

DUAL CAM HP SWAY CONTROL



Reese #: 26002

Dual Cam **HP**



Ref.	Part No.	Qty	Description
1	58435	2	Service kit - cam arm with (2) 1-14" adjustable hex nuts and washers
2	58192	2	Chain hanger bracket
3	58437	8	1/2"-13 thread forming screw
4	58033	2	Service kit - snap-up

ELITE™ 18K FIFTH WHEEL HITCH

Reese #: 30142



ELITE

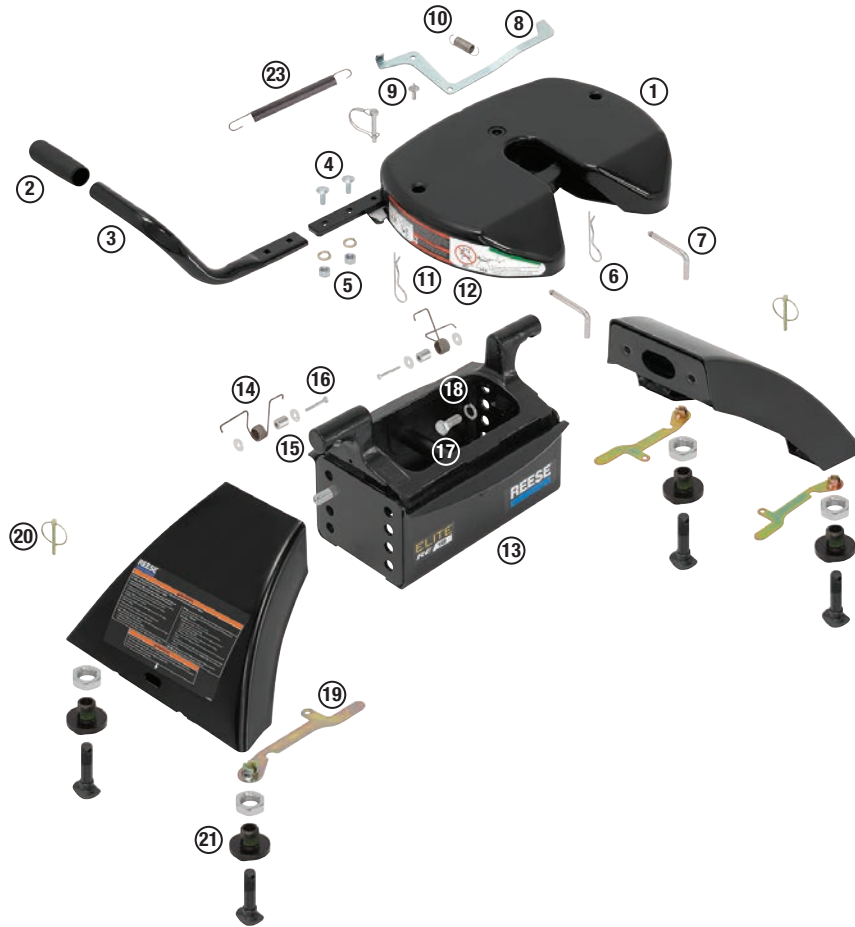

Ref.	Part No.	Qty.	Description
	117300		18K Head Kit
1		1	18K Head
2		2	Grip, Vinyl
3		1	Handle Tube
4		2	3/8 Carriage Bolt
5		2	Nut, 3/8
8		1	Indicator Flag
9		1	Drive Rivet
10		1	Spring, 1.75"
11		1	Label, Op. Warning
12		1	Label, Pinch Pt.
	58215		Handle Kit
2		1	Grip, Vinyl
3		1	Handle Tube
4		2	Carriage Bolt, 3/8
5		2	Nut, 3/8
	58240		Pull Pin Kit (90 Deg)
6		2	Clip
7		2	Pull Pin, 90 Deg
	58216		Indicator Flag Kit
8		1	Indicator Flag
9		1	Drive Rivet
10		1	Spring, 1.75"

Ref.	Part No.	Qty.	Description
13	58225	1	18K Center Section with Bumpers
	58229		Head Pivot Springs
14		2	Torsion Spring
15		2	Tube Spacer
16		2	Thumb Screw
20	111428	1	Linch Pins
	58419		Foot Assembly Kit
21		4	Foot Assembly, A&B
23	58230	1	Jaw Spring
17	58255†	1	Pointed Bolt Kit
19	58276	1	Wrench
18	58514	1	Center Section Shim Kit

ELITE™ 25K FIFTH WHEEL HITCH



Reese #: 30143

ELITE

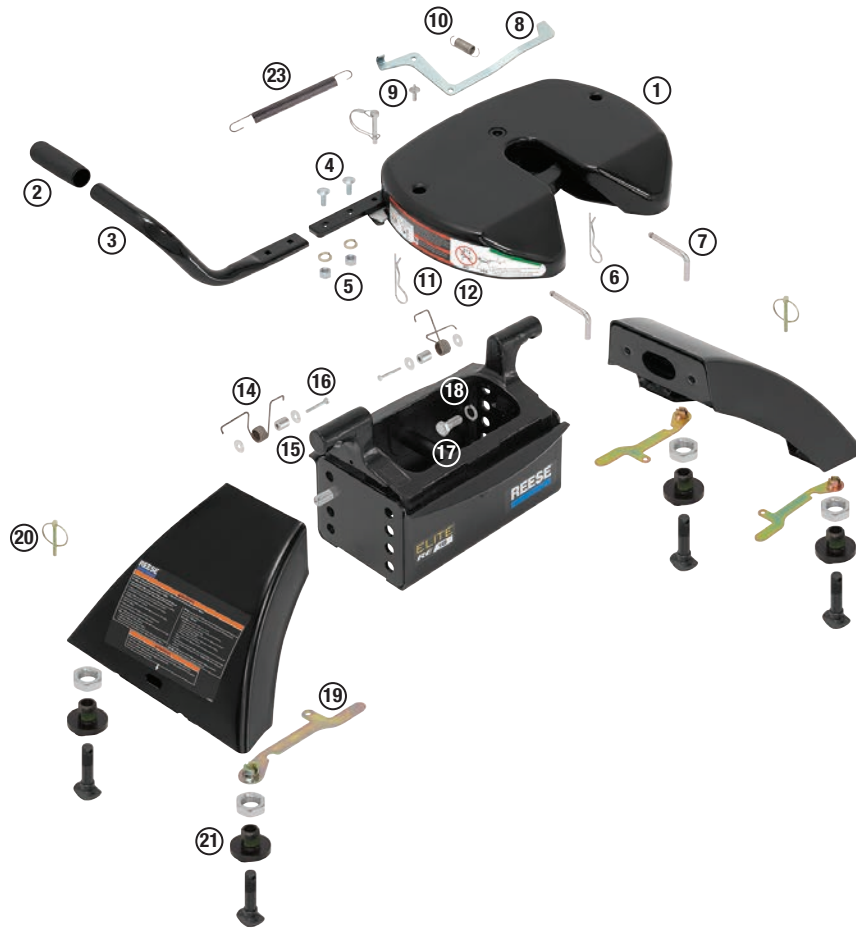

Ref.	Part No.	Qty.	Description
	117300		25K Head Kit
1		1	25K Head
2		2	Grip, Vinyl
3		1	Handle Tube
4		2	3/8 Carriage Bolt
5		2	Nut, 3/8
8		1	Indicator Flag
9		1	Drive Rivet
10		1	Spring, 1.75"
11		1	Label, Op. Warning
12		1	Label, Pinch Pt.
	58215		Handle Kit
2		1	Grip, Vinyl
3		1	Handle Tube
4		2	Carriage Bolt, 3/8
5		2	Nut, 3/8
	58240		Pull Pin Kit (90 Deg)
6		2	Clip
7		2	Pull Pin, 90 Deg
	58216		Indicator Flag Kit
8		1	Indicator Flag
9		1	Drive Rivet
10		1	Spring, 1.75"

Ref.	Part No.	Qty.	Description
	58229		Head Pivot Springs
14		2	Torsion Spring
15		2	Tube Spacer
16		2	Thumb Screw
20	111428	1	Linch Pins
	58419		Foot Assembly Kit
21		4	Foot Assembly, A&B
23	58230	1	Jaw Spring
17	58255†	1	Pointed Bolt Kit
19	58276	1	Wrench
18	58514	1	Center Section Shim Kit

ELITE™ 26.5K FIFTH WHEEL HITCH



Reese #: 30871

ELITE

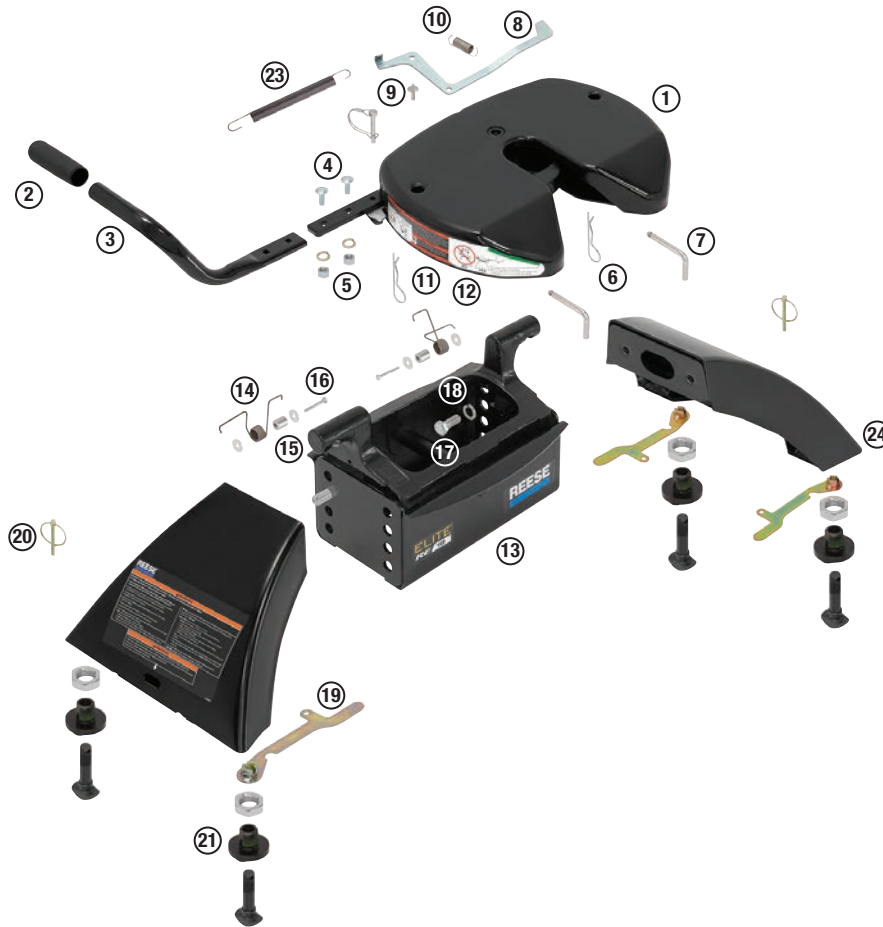

Ref.	Part No.	Qty.	Description
	117300		18K Head Kit
1		1	18K Head
2		2	Grip, Vinyl
3		1	Handle Tube
4		2	3/8 Carriage Bolt
5		2	Nut, 3/8
8		1	Indicator Flag
9		1	Drive Rivet
10		1	Spring, 1.75"
11		1	Label, Op. Warning
12		1	Label, Pinch Pt.
	58215		Handle Kit
2		1	Grip, Vinyl
3		1	Handle Tube
4		2	Carriage Bolt, 3/8
5		2	Nut, 3/8
	58240		Pull Pin Kit (90 Deg)
6		2	Clip
7		2	Pull Pin, 90 Deg
	58216		Indicator Flag Kit
8		1	Indicator Flag
9		1	Drive Rivet
10		1	Spring, 1.75"

Ref.	Part No.	Qty.	Description
13	58541	1	26.5K Center Section with Bumpers
	58229		Head Pivot Springs
14		2	Torsion Spring
15		2	Tube Spacer
16		2	Thumb Screw
20	111428	1	Linch Pins
	58419		Foot Assembly Kit
21		4	Foot Assembly, A&B
23	58230	1	Jaw Spring
17	58542	1	Pointed Bolt Kit
19	58276	1	Wrench
18	58514	1	Center Section Shim Kit
24	58543	2	26.5K Wheel Base Arch



16K FIFTH WHEEL HITCH

Reese #: 30866†

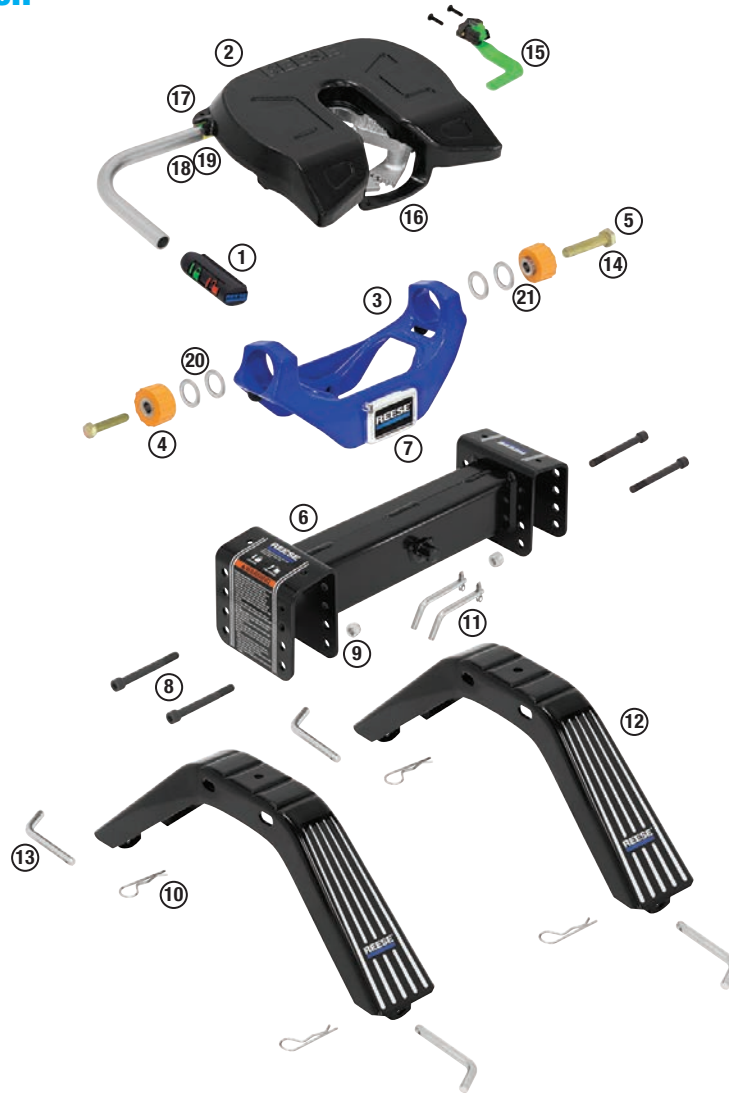

Ref.	Part No.	Qty.	Description
6	58445	1	16K Fifth Wheel Head Support
2	58446	1	16K Fifth Wheel Head
	58447		Pivot Beam Kit
3		1	16K Pivot Beam
4		2	16k Isolator
5		2	Bolt,5/8" GR8
14		2	Washer 5/8"
12	58449	2	Mounting Legs
1	58450	1	Grip, Rubber Handle
7	58451	1	Logo Plate with Hardware
	58467		Hole Style Pins
10		4	Clip,Spring
13		4	Pin,Pull
15	58489	1	Kingpin Indicator with hardware

Ref.	Part No.	Qty.	Description
	58490		Fastener Kit 16K
8		4	Socket Head Bolt, 1/2"
9		4	Nylock,Nut 1/2"
10		4	Clip,Spring
11		2	Pin,Locking
13		4	Pin,Pull
	58491		Linkage,Jaw and Bushing
16	58491	1	Jaw Linkage and bushing
	58492		Bushing,Handle with hardware
17		1	Handle Bushing
18		2	Bolt,.250
19		2	Nylock,Nut .250
	58515		16k Isolator kit
4		2	Isolator,16K
20		4	Snubbers
21		2	Inner bushing
5		2	Bolt,5/8" GR8
14		2	Washer 5/8"

† = Available while supplies last.

16K FIFTH WHEEL HITCH

Reese #: 30047

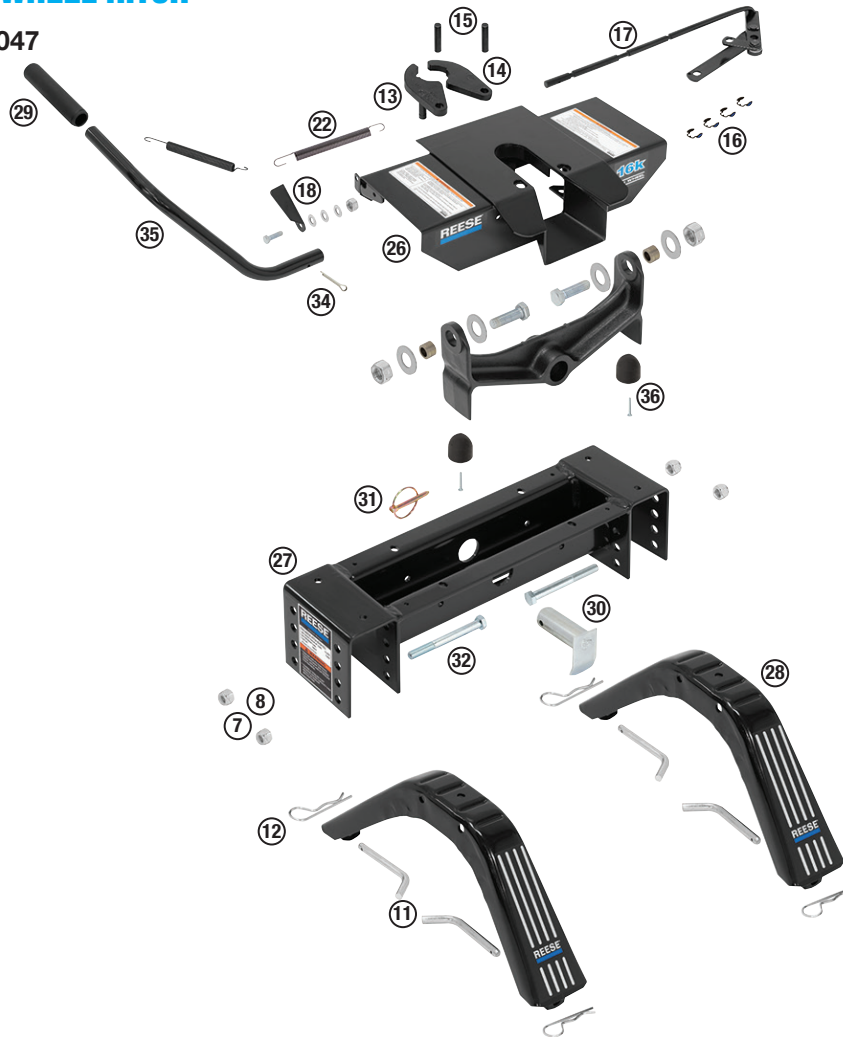

Ref.	Part No.	Qty	Description
26	58146	1	16K head assembly
27	58147	1	16K head support
	58053		Pull pin kit
11		4	Pull pins
12		4	Spring cotter pins
	58056		Jaw kit
13		1	Jaw LH (weldment)
14		1	Jaw RH (weldment)
15		2	Jaw pivot pins
16		4	Klip rings
	58055		Handle kit
29		1	Cushion grip
34		1	Cotter pin
35		1	Handle tube

Ref.	Part No.	Qty	Description
29	58094	1	Cushion grip
17	30579	1	Actuating rod
	58054		Klip ring kit
16		10	Klip rings
	30776		Spring kit
22		1	Spring
	58521		16K Head assembly hardware
7		4	1/2" nut
8		1	1/2" lock washer
11		4	Pull pins, long
12		4	Spring cotter pins
26		1	Head assembly
27		1	Head support
32		4	1/2"-13 x4.5" HNCS
30	58484	1	Pivot pin
31	55478	1	Klik pin
18	30416	1	Locking latch
28	30727	2	Legs only
36	58089		Bumper Kit
		2	8-32x1 screw
		2	8-32 nut
		2	Bumpers

20K FIFTH WHEEL HITCH

Reese #: 30867†

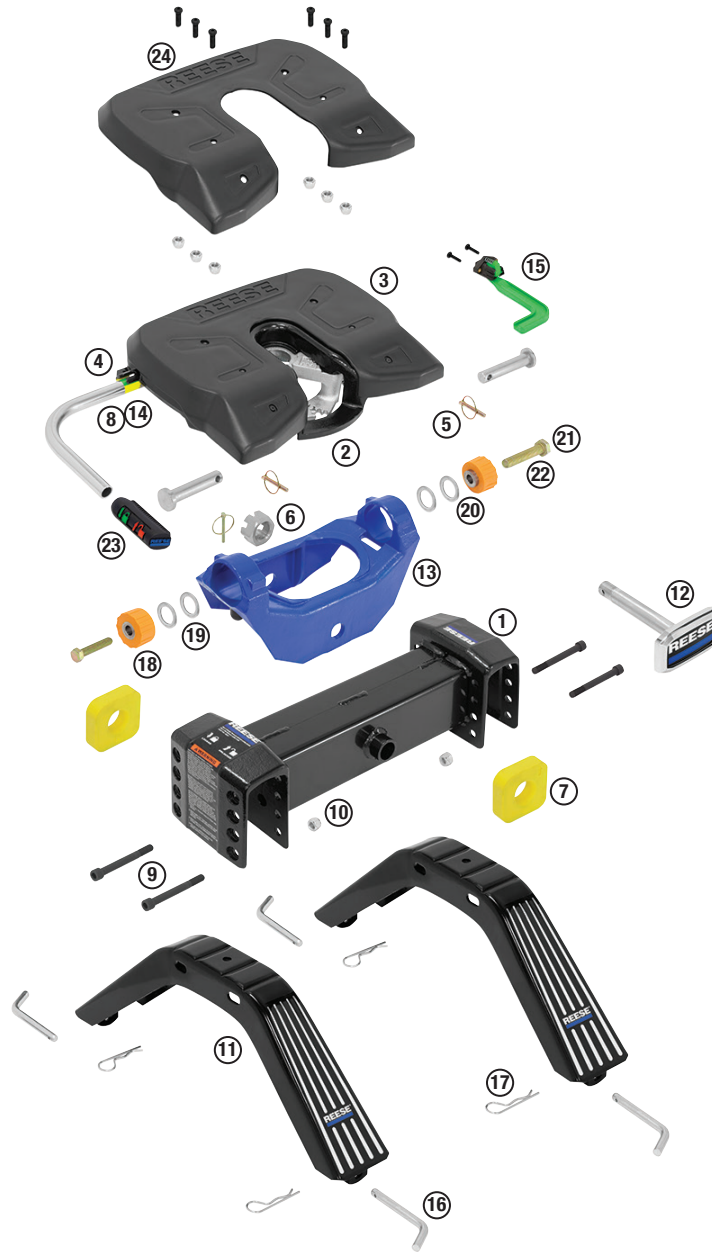

Ref.	Part No.	Qty.	Description
11	58449	2	Mounting Legs
1	58452	1	20K Head Support
3	58453	1	20K Head Kit
13	58454	1	20K Pivot Beam with Isolators
7	58455	2	Fore/Aft Isolator Kit
	58456		20K Pivot Pin w/Logo Kit
12		1	Pivot Pin w/Logo & Hardware
5		1	Klik Pin
6		1	Castle Nut
2	58491	1	Jaw Linkage and Busing
23	58450	1	Grip, Rubber Handle
	58492		Bushing, Handle w/Hardware Kit
4		1	Handle Bushing
8		2	Bolt, .250
14		2	Nylock, Nut, .250

Ref.	Part No.	Qty.	Description
15	58502	1	20K Kingpin Indicator w/Hardware
24	58457	1	Lube Plate w/Mounting Hardware
	58511		20K Fastener Kit
9		4	1/2-13 x 4 1/4" Allen Head Bolt
10		4	1/2"-13 Nylock Nut
16		4	Pull Pins with Holes
17		4	Spring Clips
	58516		20K Isolator Kit
18		2	Isolator, 20K
19		4	Snubbers
20		2	Inner Bushing
21		2	Bolt, 5/8" GR8
22		2	Washer, 5/8"

† = Available while supplies last.

20K FIFTH WHEEL HITCH

Reese #: 30081

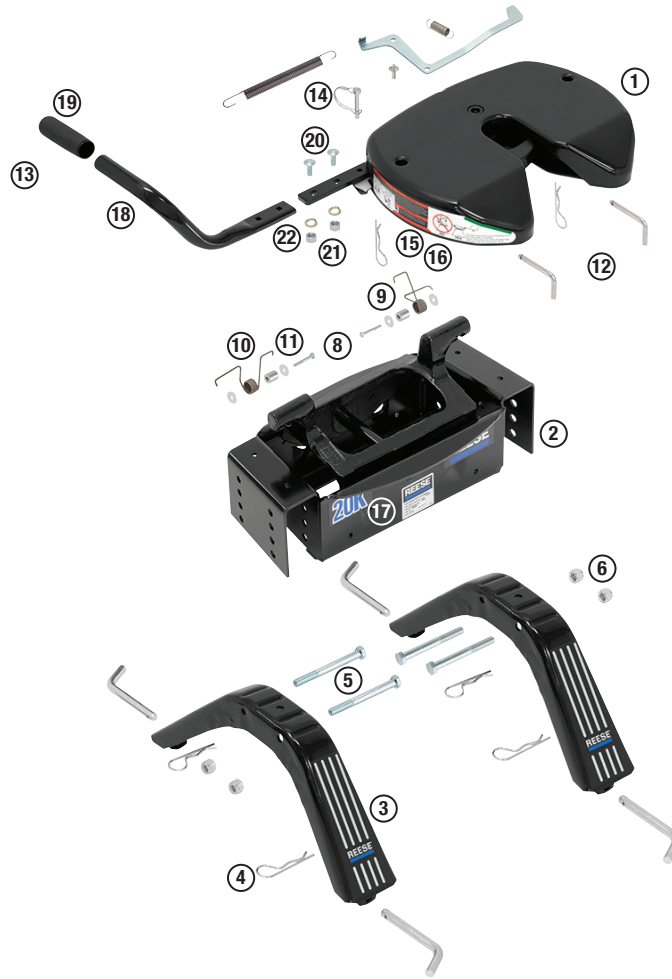

Ref.	Part No.	Qty.	Description
3	30727	2	Service Kit Arches (2x legs) Arches
18	58215	1	Handle Kit
19		1	Handle Tube
20		2	Carriage Bolt 3/8"
21		2	Nut 3/8"
22		2	Lockwasher 3/8"
	58216		Indicator Flag Kit
	58229		Head Pivot Springs
8		2	1/4" - 20 x 1.5 Hex Head Bolt
9		2	Tube Spacer
10		4	LH & RH Torsion Spring
11		4	1/4" Washer
	58230		Jaw Springs
	58240		Pull Pin Kit (90 degree) Head -Pull Pin Service Kit
4		2	Clip
12		2	Pull Pin (90 degree)

Ref.	Part No.	Qty.	Description
2	58293		20K Service Kit Center Section Weldment, 20K Center
17		2	Label, 20K 5th Wheel
	58296		Center Section Bolt Kit
5		4	1/2-13 x 4.5 Grade 5 Bolt
6		4	1/2-13 Lock Nut
	117300		20K Head Service Kit
1			20K Head Assembly
13			Hang Tag
14			Bail Pin with Lanyard
15			Warning Label
16			Head Warning Label
18			Handle Tube
19			Handle Grip
20			Carriage Bolts
21		2	3/8 Nut
22		2	3/8 Lockwasher



22K FIFTH WHEEL HITCH

Reese #: 30033

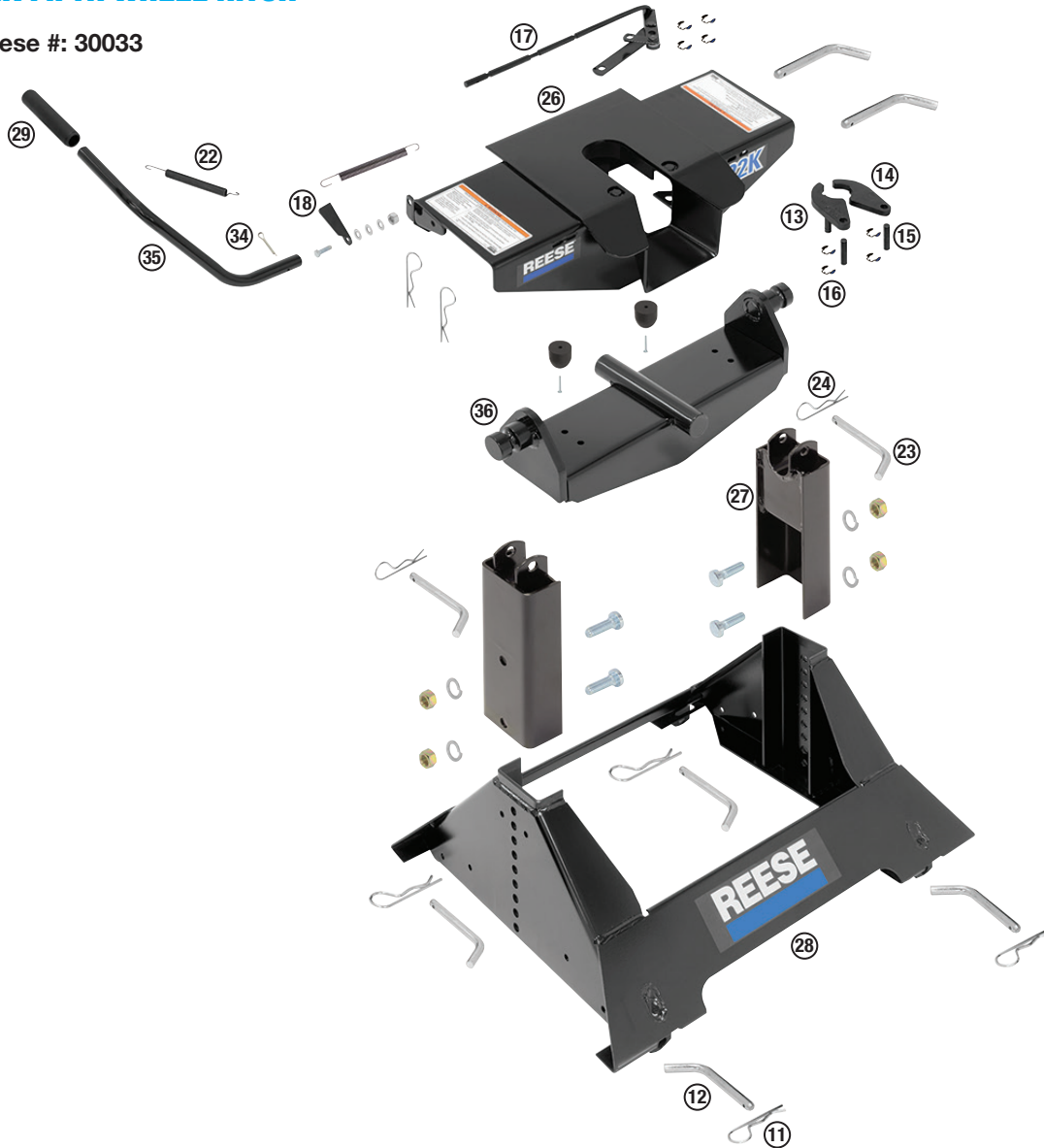

Ref.	Part No.	Qty.	Description
	6020		Pull pin kit
23		1	Pull pin
24		1	Spring clip
18	30416	1	Locking latch
17	30579	1	Actuating rod
	30730		Base with adjustment brackets
27		2	Adjustment brackets
28		1	Base Assembly
	30776		Spring kit
22		1	Spring
	58053		Pull pin kit
12		4	Pull pins
11		4	Spring cotter pins
16	58054		Klip ring kit
		10	Klip rings

Ref.	Part No.	Qty.	Description
	58055		Handle kit
29		1	Cushion grip
34		1	Cotter pin
35		1	Handle tube
	58056		Jaw kit
13		1	Jaw LH (weldment)
14		1	Jaw RH (weldment)
15		2	Jaw pivot pins
16		4	Klip rings
29	58094	1	Cushion grip
26	58099	1	22K head
36		1	Pivot beam

FIFTH WHEEL RAIL KIT



Part #: 30035

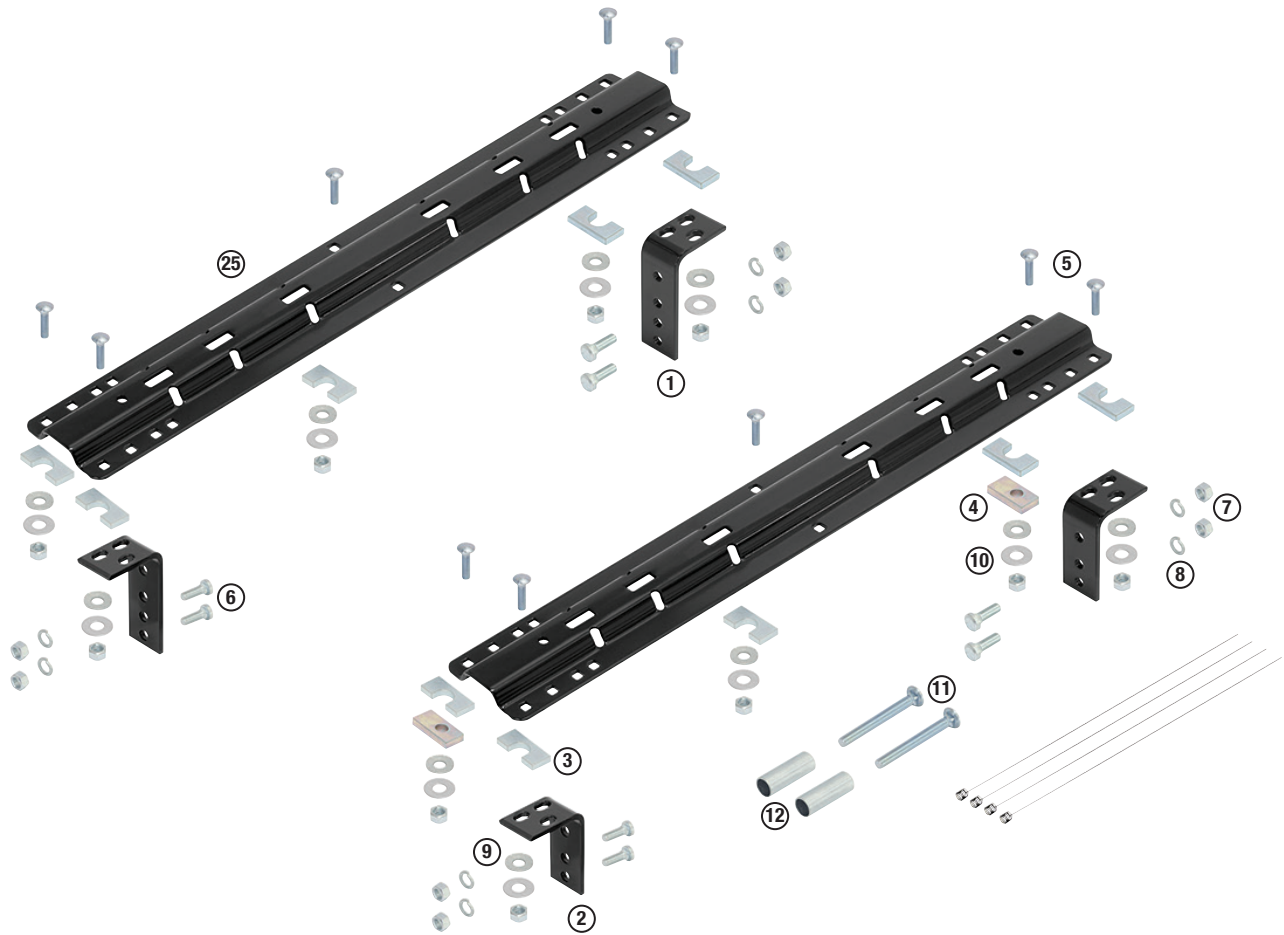

Ref.	Part No.	Qty.	Description
	30439		Mounting kit – less rails
1		2	Brackets – long
2		2	Brackets – short
3		10	Spacer
4		2	Spacers
5		10	Carriage bolts (1/2" -13 x 2")
6		8	Knurl bolts (1/2"-13 x 1-1/2")
7		18	Hex nut heads (1/2"-13)
8		18	Lock washers (1/2")
9		6	Conical washers (1/2")
10		4	Flat washers (1/2")
11		2	Carriage bolts (1/2"-13 x 4")
12		2	Bushings

Ref.	Part No.	Qty.	Description
25	58058	2	Base rail kit – less mounting kit
	58166		Dodge hardware upgrade kit (2002 half-ton only)
11		2	Carriage bolts (1/2"-13 x 4")
12		2	Bushings
	58164	1	Rail kit hardware (minus mounting brackets)
	58314	1	Mounting brackets (minus hardware)
6	55055	1	Knurl bolt (1/2"-13 x 1-1/2")

BULLDOG® TOUGH & TRUSTED



TECHNICAL

ELECTRICAL WIRING

Trailer Wiring Diagram.	2
4-Way Round Pin/Flat Connector Wiring Diagram.	3
5-Way Flat Connector Wiring Diagram.	3
6-Way Round Pin Connector Wiring Diagram.	3
7-Way RV Blade Connector Wiring Diagram.	4
7-Way Molded Trailer Connectors.	4

BRAKE CONTROLS

Electric Brake Control Wiring Instructions.	5
Brake Control Wiring Harness Chart.	7-8
Trailer Emulator Reference Guide.	9-10

JACKS

F2 Jack - Weld-On Bracket Mounting Positions.	11
F2 Jack - Adjusting the Swivel Mount Height.	12
Jack Replacement Reference Guide.	13-14
Jack Assembly Reference Guide.	15

POWER WINCHES

Electric Winch Performance Data & Dimensions.	17-19
Hydraulic Winch Performance Data & Dimensions.	20
Electric Hoist Performance Data & Dimensions.	21-22

LIGHTING

Trailer Lighting Federal Equipment Requirements.	23-24
Truck Lighting Federal Equipment Requirements.	25-26
AG Lighting Wiring Diagrams.	27
AG Lighting Wiring Diagram with Brake.	28
AG Lighting Information.	29

TRAILER ACCESSORIES

Breakaway Switch Installation Instructions.	30
ABCD Instruction and Installation.	31
Tow Charger Instructions and Installation.	32
12 Volt Battery Instruction and Installation.	32
Trailer Brake Troubleshooting / Adjustment.	33
Electric Trailer Brake Part Identification.	34

TOOLS / TESTERS

Bench Tester Instructions.	35
Current Monitor Instructions.	35
Trailer Tester Instructions.	36

WIRING DIAGRAM FOR TYPICAL 4-WAY CONNECTOR

(5-WAY CONNECTOR WOULD INCLUDE BLUE WIRE FOR AUXILIARY)

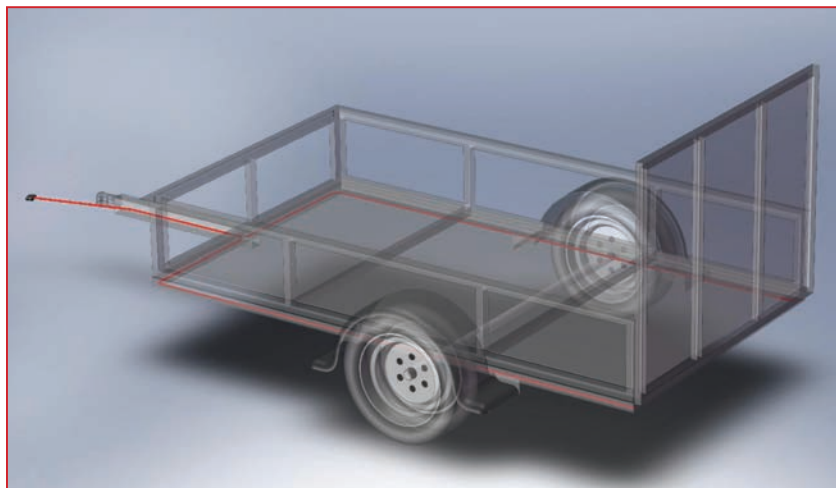
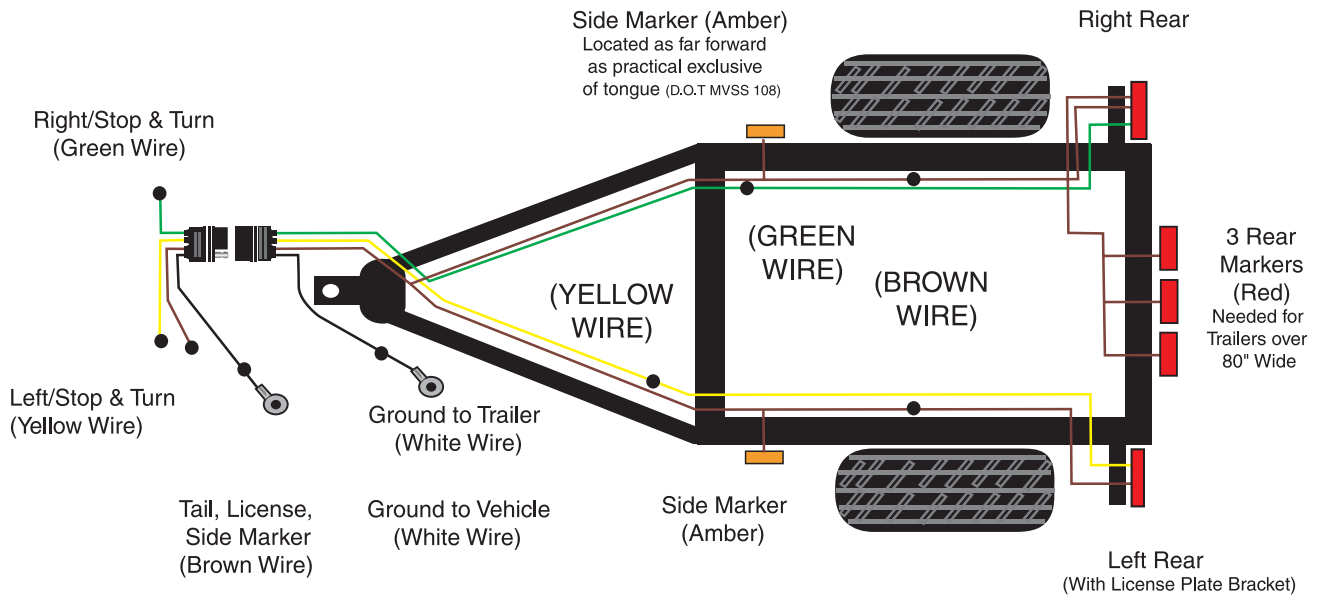

6-WAY ROUND PIN CONNECTOR WIRING DIAGRAM

6-WAY MOLDED TRAILER/ SEALED CAR CONNECTOR & CABLE

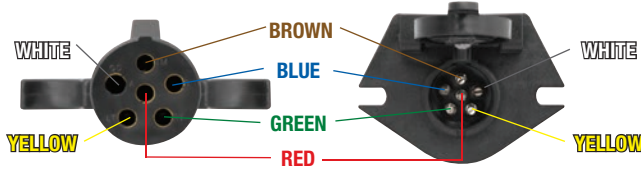

TRAILER END
As viewed from front face of 6-way connector with molded on cable.

CAR END
As viewed from front face of 6-way connector with sealed cable.

6-WAY ZINC DIE-CAST CONNECTOR



TRAILER END
As viewed from core back side where wires are attached with screws.

CAR END
As viewed from core back side where wires are attached with screws.

6 - WAY WIRING INDEX

Wire Color & Gauge	Molded Trailer/Sealed Car Connector Terminal	Zinc Die-Cast Connector Terminal
White / 10/14 gauge	Common Ground	GD - Common Ground
Blue / 10/14 gauge	Electric Brake	S - Electric Brake
Green / 14 gauge	Right Stop & Turn	TM - Tail & License
Red / 10/14 gauge	Auxiliary	LT - Left Stop & Turn
Brown / 14 gauge	Tail & License	RT - Right Stop & Turn
Yellow / 14 gauge	Left Stop & Turn	A - Auxiliary

4-WAY ROUND PIN / FLAT CONNECTOR WIRING DIAGRAM

4-WAY ROUND PIN CONNECTOR

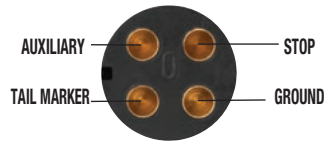

TRAILER END
As viewed from core back side where wires are attached with screws.

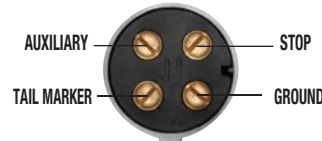

CAR END
As viewed from core back side where wires are attached with screws.

4-WAY FLAT CONNECTOR

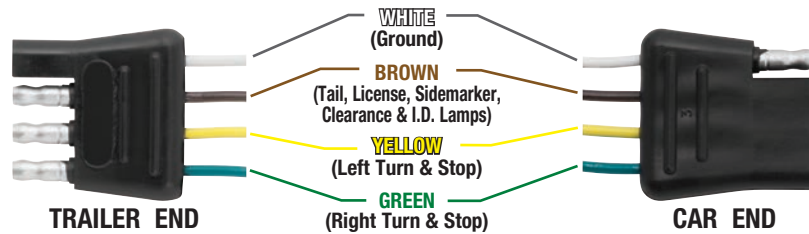

5-WAY FLAT CONNECTOR WIRING DIAGRAM

5-WAY FLAT CONNECTOR

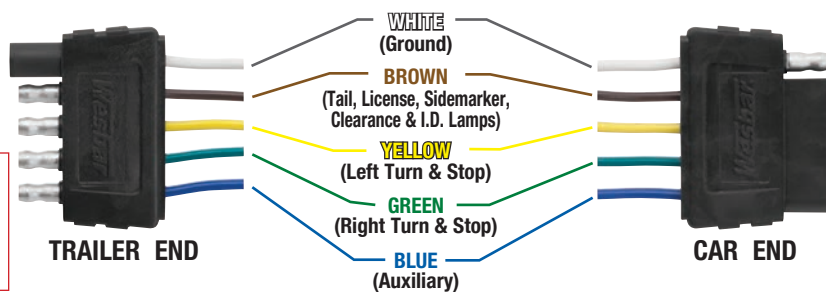

TECHNICAL INFORMATION IS CURRENT AS OF THE PRINTING OF THIS CATALOG. CONTACT TECHNICAL SERVICE FOR PERIODIC UPDATES.

7-WAY RV BLADE CONNECTOR WIRING DIAGRAM

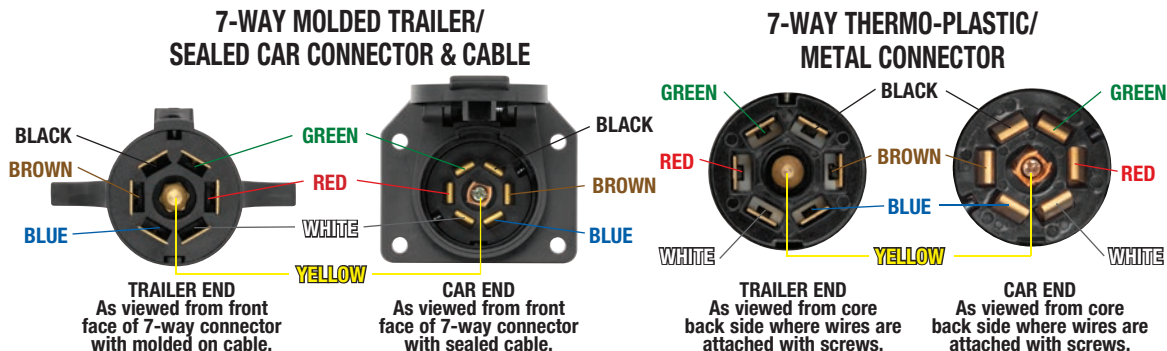

7 - WAY W I R I N G I N D E X

Wire Color & Gauge	Molded Trailer/Sealed Car Connector Terminal	Thermo-Plastic/Metal Connector Terminal
White / 10 gauge	Common Ground	#1 Common Ground
Blue / 12 gauge	Electric Brake	#2 Electric Brake
Green / 14 gauge	Tail & License	#3 Tail & License
Black / 10 gauge	Battery Charge	#4 Battery Charge
Red / 14 gauge	Left Stop & Turn	#5 Left Stop & Turn
Brown / 14 gauge	Right Stop & Turn	#6 Right Stop & Turn
Yellow / 14 gauge	Center Auxiliary	#7 Center Auxiliary

7-WAY MOLDED TRAILER CONNECTORS

PIN CLOCKING

Cold Weather RV - Gauge 2/10, 1/12, 4/14

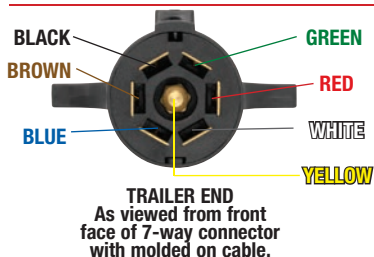

WIRE COLOR, GAUGE & FUNCTION
White / 10 gauge / Common Ground
Blue / 12 gauge / Electric Brake
Green / 14 gauge / Tail & License
Black / 10 gauge / Battery Charge
Red / 14 gauge / Left Stop & Turn
Brown / 14 gauge / Right Stop & Turn
Yellow / 14 gauge / Center Auxiliary

Heavy Duty Trailer - Gauge 2/10, 1/12, 4/14

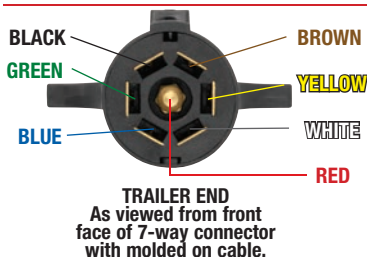

WIRE COLOR & GAUGE
White / 10 gauge
Blue / 12 gauge
Green / 14 gauge
Black / 10 gauge
Red / 14 gauge
Brown / 14 gauge
Yellow / 14 gauge

Cold Weather - Gauge 3/10, 4/14

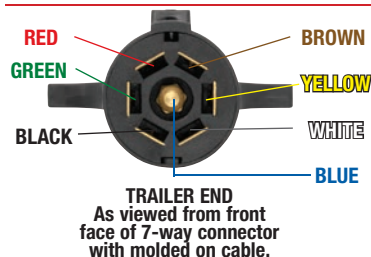

WIRE COLOR & GAUGE
White / 10 gauge
Blue / 14 gauge
Green / 14 gauge
Black / 10 gauge
Red / 10 gauge
Brown / 14 gauge
Yellow / 14 gauge

TECHNICAL INFORMATION IS CURRENT AS OF THE PRINTING OF THIS CATALOG. CONTACT TECHNICAL SERVICE FOR PERIODIC UPDATES.

NOTE: 7-Way Heavy Duty and Cold Weather trailer wiring diagrams represent wire location and color but are NOT supplied to represent any wire or color functions. Please contact your trailer manufacturer for further details.

WIRE INSTRUCTIONS FOR ELECTRONIC BRAKE CONTROLS

Generic Wiring Diagram

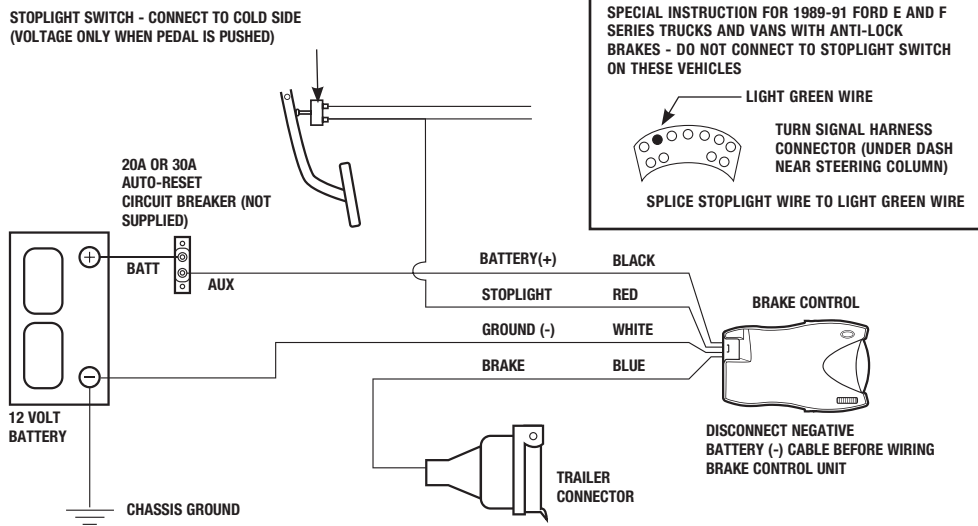

READ THIS FIRST:

Read and follow all instructions carefully before wiring brake control. Keep these instructions with the brake control for future reference.

Important Facts to Remember

1. The brake control must be installed with a 12 volt negative ground system. (To install with a positive ground system use Tekonsha® P/N 3191.)
2. **WARNING** Reversing BLACK and WHITE wires or improper wiring will damage or destroy brake control.
3. **WARNING** Be sure to solidly connect all four wires or brake control will not function properly.
4. Soldering is recommended or crimp-on butt connectors are a suitable substitution.
5. Route all wires as far from the radio antenna as possible to reduce AM interference.

6. **CAUTION** Use of proper gauge wire when installing the brake control is CRITICAL; smaller gauge wire may result in less than efficient braking. Minimum wire gauges are as follows:
 - 1-2 axle applications – 14 GA.
 - 3-4 axle applications – 12 GA.
7. Collection of water inside the trailer connector mounted on the tow vehicle will reduce the life of the connector.

Wiring Legend

- BLACK Wire (Positive Battery)
- WHITE Wire (Negative Battery)
- RED Wire (cold side of stoplight switch)
- BLUE Wire (brake output to trailer)

1. The WHITE (-) wire must be connected to a known ground.
2. **CAUTION** Inadequate grounding may cause intermittent braking or lack of sufficient voltage to trailer brakes. The WHITE wire must be connected to a suitable ground location. The negative terminal of the battery is a suitable ground location in the absence of a Trailer Tow Package connection.
3. Connect BLACK (+) wire through an automatic reset circuit breaker (20 amp for 1-2 axles, 30 amp for 3-4 axles) to the POSITIVE (+) terminal of the battery. The BLACK wire is the power supply line to the brake control.
4. The RED (stoplight) wire must be connected to the cold side of the brake pedal stoplight switch. Splice down line from the switch; DO NOT disturb the position of the switch.
5. The BLUE (brake output) wire must be connected to the trailer connector's brake wire.

TECHNICAL INFORMATION IS CURRENT AS OF THE PRINTING OF THIS CATALOG. CONTACT TECHNICAL SERVICE FOR PERIODIC UPDATES.

BRAKE CONTROL WIRING HARNESS CHART

⚠ WARNING When using a wiring harness supplied by your vehicle's Manufacturer (OE Harness), DO NOT MATCH COLORS. Please follow wiring chart below.

OE HARNESS	BRAKE CONTROL WIRE	FUNCTION
CHEVROLET		
RED	BLACK	12 VOLT
LIGHT BLUE	RED	STOPLIGHT
BLACK	WHITE	GROUND
DARK BLUE	BLUE	TRAILER BRAKES
BROWN	N/A	ILLUMINATION
GM 2007 AND NEWER (NEW BODY STYLE)		
RED / BLACK TRACER	BLACK	12 VOLT
LIGHT BLUE / WHITE TRACER	RED	STOPLIGHT
WHITE	WHITE	GROUND
DARK BLUE	BLUE	TRAILER BRAKES
ORANGE	N/A	STOPLIGHT
DODGE (GREEN WIRE)		
WHITE W/ RED TRACER	BLACK	12 VOLT
BLUE W/ WHITE TRACER	RED	STOPLIGHT
GREEN W/ BLACK TRACER	WHITE	GROUND
BLUE	BLUE	TRAILER BRAKES
DODGE		
RED W/ BLACK TRACER	BLACK	12 VOLT
WHITE W/ TAN TRACER	RED	STOPLIGHT
BLACK	WHITE	GROUND
BLUE	BLUE	TRAILER BRAKES
2010 & NEWER DODGE		
YELLOW W/ GREEN TRACER	BLACK	12 VOLT
WHITE	RED	STOPLIGHT
BLACK W/ GREEN TRACER	WHITE	GROUND
GREEN	BLUE	TRAILER BRAKES
2010 & NEWER DODGE		
YELLOW W/ RED TRACER	BLACK	12 VOLT
WHITE	RED	STOPLIGHT
BLACK W/ GREEN TRACER	WHITE	GROUND
GREEN	BLUE	TRAILER BRAKES
FORD (PINK WIRE)		
PINK	BLACK	12 VOLT
RED	RED	STOPLIGHT
WHITE	WHITE	GROUND
BLUE	BLUE	TRAILER BRAKES
BROWN	N/A	ILLUMINATION
FORD		
RED	BLACK	12 VOLT
LIGHT GREEN	RED	STOPLIGHT
WHITE	WHITE	GROUND
DARK BLUE	BLUE	TRAILER BRAKES
BROWN	N/A	ILLUMINATION
FORD (PURPLE WIRE)		
RED	BLACK	12 VOLT
PURPLE W/ WHITE TRACER	RED	STOPLIGHT
BLACK W/ WHITE TRACER	WHITE	GROUND
BLUE	BLUE	TRAILER BRAKES
BROWN	N/A	ILLUMINATION
FORD 2008 SUPER DUTY		
RED	BLACK	12 VOLT
YELLOW W/ GREEN TRACER	RED	STOPLIGHT
BLACK W/ GRAY TRACER	WHITE	GROUND
BLUE	BLUE	TRAILER BRAKES

BRAKE CONTROL WIRING HARNESS CHART (CONTINUED)

▲ WARNING When using a wiring harness supplied by your vehicle's Manufacturer (OE Harness), DO NOT MATCH COLORS. Please follow wiring chart below.

OE HARNESS	BRAKE CONTROL WIRE	FUNCTION
FORD		
RED	BLACK	12 VOLT
GREEN	RED	STOPLIGHT
WHITE	WHITE	GROUND
BLUE	BLUE	TRAILER BRAKES
FORD		
BROWN W/ RED TRACER	BLACK	12 VOLT
BLUE W/ ORANGE TRACER	RED	STOPLIGHT
GRAY W/ BLACK TRACER	WHITE	GROUND
BLUE	BLUE	TRAILER BRAKES
TOYOTA		
BLACK W/ RED TRACER	BLACK	12 VOLT
GREEN	N/A	ILLUMINATION
GREEN W/ WHITE TRACER	RED	STOPLIGHT
BROWN	WHITE	GROUND
RED	BLUE	TRAILER BRAKES
TOYOTA / LEXUS		
BLACK	BLACK	12 VOLT
GREEN W/ YELLOW TRACER	RED	STOPLIGHT
WHITE W/ BLACK TRACER	WHITE	GROUND
YELLOW	BLUE	TRAILER BRAKES
GREEN	N/A	ILLUMINATION
NISSAN / INFINITY		
RED	BLACK	12 VOLT
RED W/ GREEN TRACER	RED	STOPLIGHT
BLACK	WHITE	GROUND
BROWN W/ WHITE TRACER	BLUE	TRAILER BRAKES
RED W/ BLUE TRACER	N/A	ILLUMINATION
VOLKSWAGEN / PORSCHE		
CAVITY #2 (RED W/ YELLOW TRACER)	BLACK	12 VOLT
CAVITY #3 (BLACK W/ RED TRACER)	RED	STOPLIGHT
CAVITY #1 (BROWN)	WHITE	GROUND
CAVITY #4 (BLUE)	BLUE	TRAILER BRAKES
HONDA		
BLUE	BLACK	12 VOLT
WHITE W/ BLACK TRACER	RED	STOPLIGHT
BLACK	WHITE	GROUND
BROWN W/ WHITE TRACER	BLUE	TRAILER BRAKES
HONDA		
BLUE	BLACK	12 VOLT
LIGHT BLUE	RED	STOPLIGHT
BLACK	WHITE	GROUND
BROWN W/ WHITE TRACER	BLUE	TRAILER BRAKES
FREIGHTLINER		
RED	BLACK	12 VOLT
SMALL RED W/ WHITE TRACER	RED	STOPLIGHT
BLACK	WHITE	GROUND
LARGE RED W/ WHITE TRACER	BLUE	TRAILER BRAKES
BROWN	N/A	ILLUMINATION
ACADIA / ENCLAVE / OUTLOOK		
RED W/ BLACK TRACER	BLACK	12 VOLT
WHITE	RED	STOPLIGHT
BLACK	WHITE	GROUND
BLUE	BLUE	TRAILER BRAKES
GREY	N/A	ILLUMINATION

TECHNICAL INFORMATION IS CURRENT AS OF THE PRINTING OF THIS CATALOG. CONTACT TECHNICAL SERVICE FOR PERIODIC UPDATES.

TRAILER EMULATOR REFERENCE GUIDE

Trailer Emulator

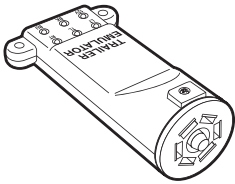

- LT – Left turn signal, Red Light
- TL – Tail / running lights, Red Light
- RT – Right turn signal, Red Light
- 12V – 12 volt battery supply line, Red Light
- BK – Electric trailer brakes, Red Light
- BU – Backup lights, Red Light

User's Guide

The Trailer Emulator requires the ground and 12 volt battery line to be properly connected in order to check the electric brake circuit.

- 12 volt light on the emulator will be lit as soon as the emulator is connected to the tow vehicle's plug. If this does not happen see Troubleshooting Chart.
 - The RT, LT, TL and BU lights will light on the emulator as those functions are activated on the tow vehicle. If this does not happen see Troubleshooting Chart.
 - The BK light on the emulator should be off until the brake control is activated. (May see a flicker but not on steady)
- NOTE:** The trailer emulator *is not an exact trailer load* so the light displays on various brake controls will respond differently.

Brake Controls with LCD Display

90195 – P3®

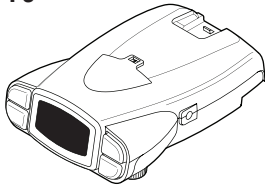

Brake Control's display should show:



- With trailer emulator connected and no manual slide activation.
- Varying voltage displayed from 0-13 as manual is activated with the power knob full on.

Brake Controls with Digital Display

90250 – Prodigy RF®

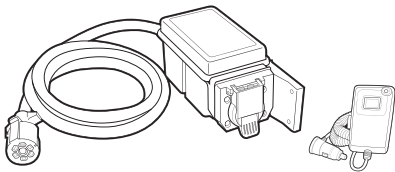

90185 – Prodigy® / 90885 – Prodigy® P2

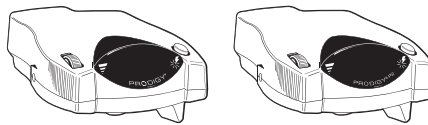

90160 – Primus™ IQ

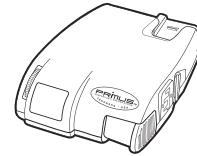

5535 – I-Command™

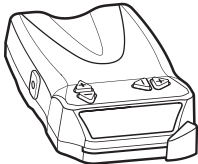

80550 – Pilot®



Brake Control's display should show:

- .c - With trailer emulator connected and no manual slide activation ("c" indicates connection to the trailer).
- Varying voltage displayed from 0-13 as manual is activated with the power knob full on.

Brake Controls with LED Display

9030 – Voyager®

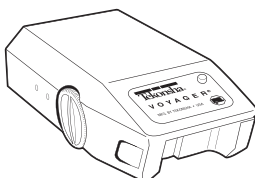

90160 – POD™

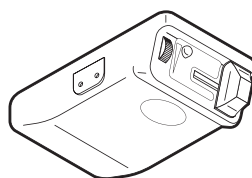

Brake Control's display should show:

- GREEN - with trailer emulator connected with no manual slide activation.
- GREEN to varying colors of RED - trailer emulator connected and manual slide activated.

TECHNICAL INFORMATION IS CURRENT AS OF THE PRINTING OF THIS CATALOG. CONTACT TECHNICAL SERVICE FOR PERIODIC UPDATES.

TRAILER EMULATOR REFERENCE GUIDE (CONTINUED)

Troubleshooting Chart

Condition	Probable Cause
<u>Trailer Emulator connected to tow vehicle:</u>	
- 12V LED is NOT lit on Trailer Emulator.	1) Bad ground or incorrect wiring in tow vehicle connector. 2) No 12 volt battery power supplied to connector.
- LT LED is NOT lit on Trailer Emulator NOTE: Applies for LT, RT, TL and BU LEDs.	1)Bad ground or incorrect wiring in tow vehicle connector. 2)Loose or poor connection in circuit under test.
- BK is NOT lit on Trailer Emulator when <u>manual slide / touch pad</u> is activated, but 12V LED is lit.	1)Bad ground or incorrect wiring in tow vehicle connector. 2)Poor ground on Brake Control. Brake Control goes into a limit mode. 3)Gain adjustment on Brake Control is set to minimum, adjust gain to maximum and retest using manual.
- BK is <u>NOT</u> lit on Trailer Emulator when <u>Brake Pedal</u> is depressed, but 12V LED is lit.	1)If using brake pedal, Tekonsha's inertia activated controls require vehicle movement to activate sensor. Apply the manual switch and see if BK LED lights. (SEE NOTE)

Note:

The following two methods are available to test the Automatic response of the Tekonsha brake control with the Trailer Emulator.

1. Vehicle in Motion Method
 - Connect Trailer Emulator to vehicle.
 - Properly adjust the Level of the brake control.
 - Drive vehicle and apply brake pedal, the brake control's light should indicate a braking event.

2. Aggressive Level Method
 - Connect Trailer Emulator to vehicle.
 - Properly adjust the Level of the brake control.
 - Adjust Level setting toward Aggressive.
 - The brake control's light should indicate a braking event.
 - When finished with test remember to adjust the brake control's level back to desired tow setting.

TECHNICAL INFORMATION IS CURRENT AS OF THE PRINTING OF THIS CATALOG. CONTACT TECHNICAL SERVICE FOR PERIODIC UPDATES.

WELD-ON BRACKET MOUNTING POSITIONS, F2[®] JACK

3x3 Tube With 3x4 Plate

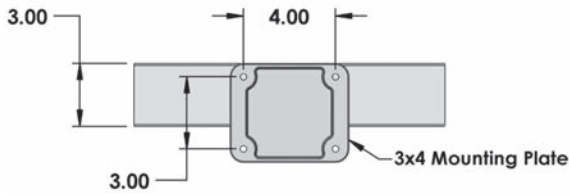

3x4 Tube With 3x4 Plate

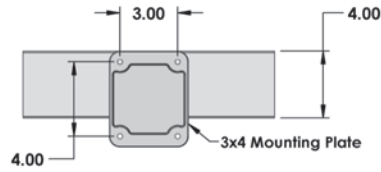

P/N	F2 MARINE AND RECREATIONAL JACKS
1413060334	F2 Twin Track Model 3" x 4" Pivot Housing. Includes Handle Hold-up Feature & Weld-on Mounting Bracket & Hardware.
1413050334	F2 Wide Track Model 3" x 4" Pivot Housing. Includes Handle Hold-up Feature & Weld-on Mounting Bracket & Hardware.
500277	Pivot Housing.

P/N	F2 MARINE AND RECREATIONAL JACKS
1413060334	F2 Twin Track Model 3" x 4" Pivot Housing. Includes Handle Hold-up Feature & Weld-on Mounting Bracket & Hardware.
1413050334	F2 Wide Track Model 3" x 4" Pivot Housing. Includes Handle Hold-up Feature & Weld-on Mounting Bracket & Hardware.
500277	Pivot Housing.

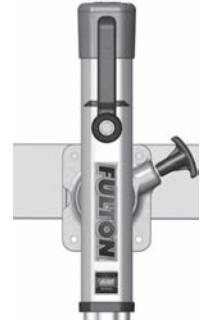

3x5 Tube With 4x5 Plate

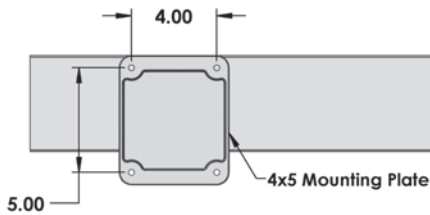

3x5 Tube With 3x4 Plate

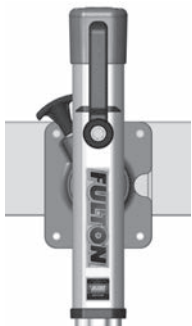
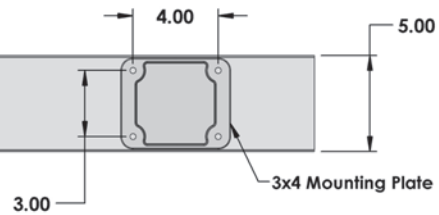

P/N	F2 MARINE AND RECREATIONAL JACKS
1413200334	Adjustable Swivel w/ Footplate Includes Handle Hold-up Feature & Weld-on Mounting Bracket & Hardware for up to 5" Frames.
500276	Pivot Housing.

P/N	F2 MARINE AND RECREATIONAL JACKS
1413060334	F2 Twin Track Model 3" x 4" Pivot Housing. Includes Handle Hold-up Feature & Weld-on Mounting Bracket & Hardware.
1413050334	F2 Wide Track Model 3" x 4" Pivot Housing. Includes Handle Hold-up Feature & Weld-on Mounting Bracket & Hardware.
500277	Pivot Housing.



ADJUSTING THE SWIVEL MOUNT HEIGHT, F2[®] JACK

Required Tools:

3/4 Socket, Ratchet Wrench, Torque wrench.

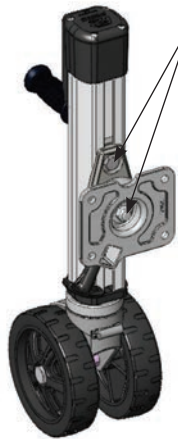

Adjusting Swivel Mount Height (If Necessary):

With jack removed from trailer, loosen the two swivel fasteners until the slide block moves freely along outer tube. To access the upper bolt be sure the swivel bracket is rotated in the horizontal (3" mounting) position as shown. Adjust swivel mount to desired location and re-torque to 60-70 ft-lbs. After adjustment, check for proper swivel and pin engagement.

Loosening factory torqued nuts and bolts on your swivel mount:

1. Cover your work area with a piece of cardboard or a towel to protect the finish on your jack.
2. Position the jack firmly on a bench at waist level.
3. Turn mounting bracket so that the pull pin is toward the caster(s).
4. Brace the gearbox against your hip and firmly grip the caster.
5. Loosen the half inch nut inside the swivel mount by pulling toward your body.

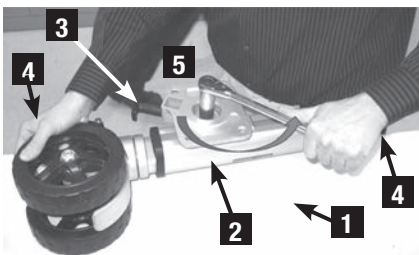

6. Remove the nut from the back of the swivel mount.

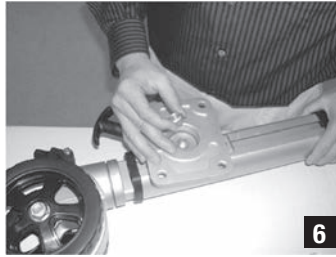

7. Pull the pull pin and remove the swivel mount.

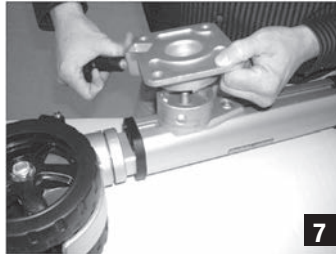

8. Loosen the standard hex bolt with the 5/16 hex wrench.

9. Adjust the mount height.

10. Re-torque the nut on the slide block to 60 ft-lbs.

Final Steps:

11. Replace the swivel mount making sure that the washer is still in place.



12. Replace the nut on the back of the swivel mount.

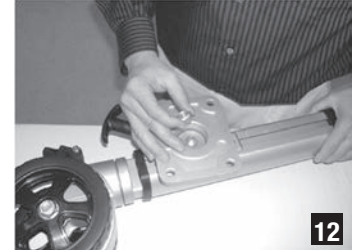

13. Re-torque the nut on the back of the swivel mount to 60 ft-lbs.

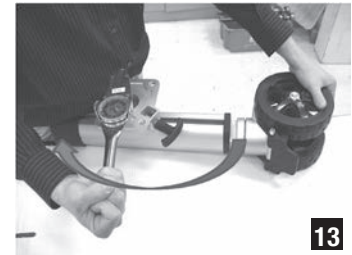

14. You are now ready to enjoy your Fulton F2 Jack.



JACK REPLACEMENT QUICK-REFERENCE GUIDE

NOTES: This Quick Reference Guide is not intended to supplement your original jack instruction sheet. This guide is only intended to help identify your jack for purposes of service and part replacement.

While servicing your jack, make sure it is not under load.

Replacement parts are intended for worn jack parts. If your jack has been damaged, replace it to prevent unsafe conditions.

Help us help you!

To ensure you receive the most accurate, prompt service possible, collect as much of the following information as possible before calling. If more than one item in a group seems to fit your jack, note all that apply and what about your jack that makes it fit that category. Some helpful pictures are shown at the bottom of the next page.

Jack Series and Capacity (Available on product label or in stamped marking)

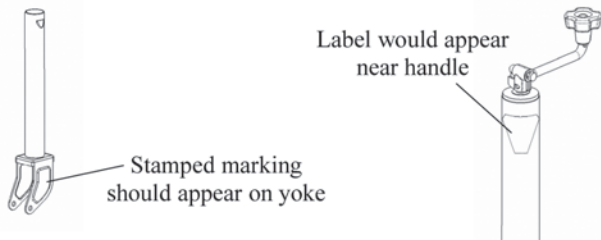

Handle Style (Available by inspection)

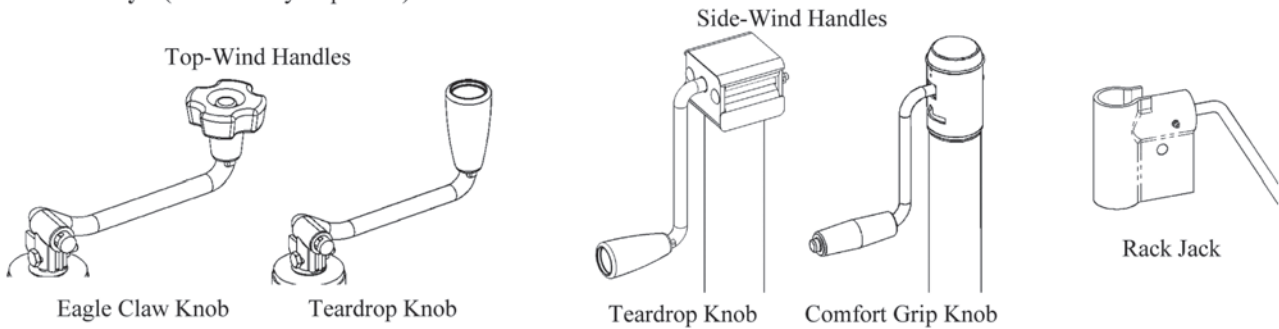

Plunger Pin Size (Available by inspection, not a feature on all jack models)

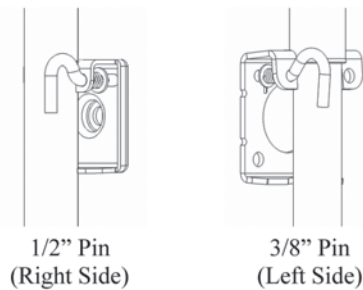

Mount Type (Available by inspection. Note if your mount is welded or bolted to your trailer tongue.)

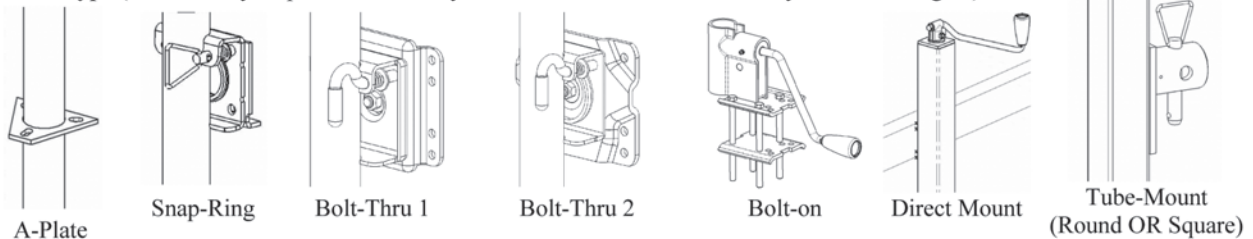

WHOLE JACK EXAMPLES

Foot/Wheel Type (Available by inspection)

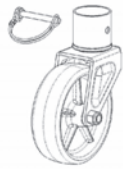

Removable Wheel
(Wheels may also be fixed to the jack)



Removable Foot
(Feet may also be fixed to the jack)



No Foot

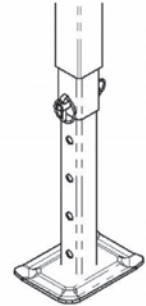

Drop Leg

Some Examples of whole jacks are below

Top-Wind,
Eagle Claw Knob,
1/2" Plunger Pin,
Snap-Ring Mount,
Fixed Regular Foot



Side-Wind,
Teardrop Knob,
Internal Gearbox,
1/2" Plunger Pin,
Bolt-Thru I Mount,
No Foot

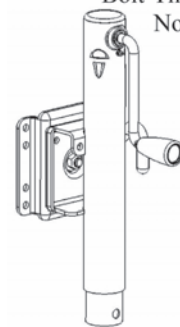

Rack Jack,
Teardrop Knob,
Bolt-on

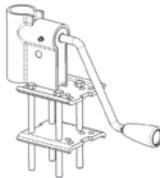

Top-Wind,
Eagle Claw Knob,
A-Plate,
Removable Wheel



Side-Wind,
Teardrop Knob,
External Gearbox,
Tube Mount,
Fixed Large Foot

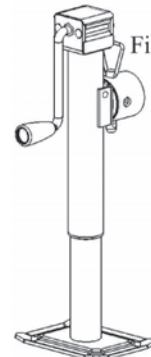

JACK ASSEMBLY REFERENCE GUIDE

Assembly Quick-Reference Guide

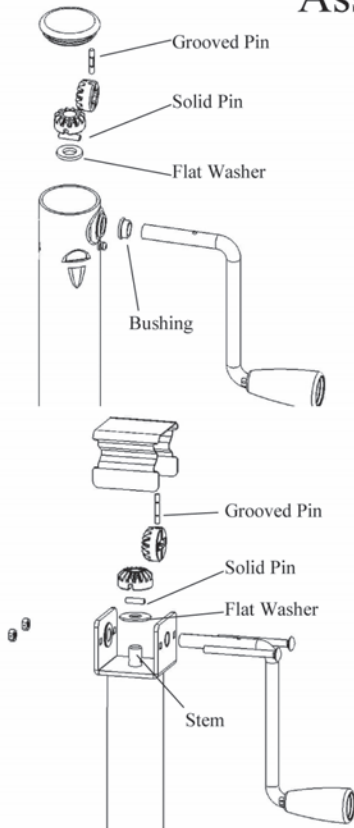

Side-Wind Jack Assembly:

- 1) Carefully remove all parts from the gearbox. The grooved pin is very secure in place and you may need to rotate the jack handle to reveal and remove it.
- 2) Place the flat washer over stem at the bottom of the gearbox.
- 3) Place the solid pin through the hole in the stem and place the gear over the solid pin so that the solid pin rests in the slot on the gear that does NOT go across the entire gear. The lower gear should be the larger of the two gears if the gears are a different size.
- 4) If you have an internal gearbox, install the bushing from inside the jack tube.
- 5) Insert the handle through the bushing and the second gear. Be sure the gear teeth are fully engaged and the handle is sticking out the far side of the jack after this step.
- 6) The grooved pin must now be inserted through the second gear and the handle. It may be necessary to rotate the handle 1/4 turn to expose the hole in the handle. The groove pin will fit very tightly and should be installed carefully to avoid damage to the jack body. Make sure the pin is centered in the handle to ensure smooth cranking.
- 7) Re-install the cap with even pressure, or with the bolts and nuts as it was removed.
- 8) Be sure the jack is assembled properly and functions as new before using it to support a load.

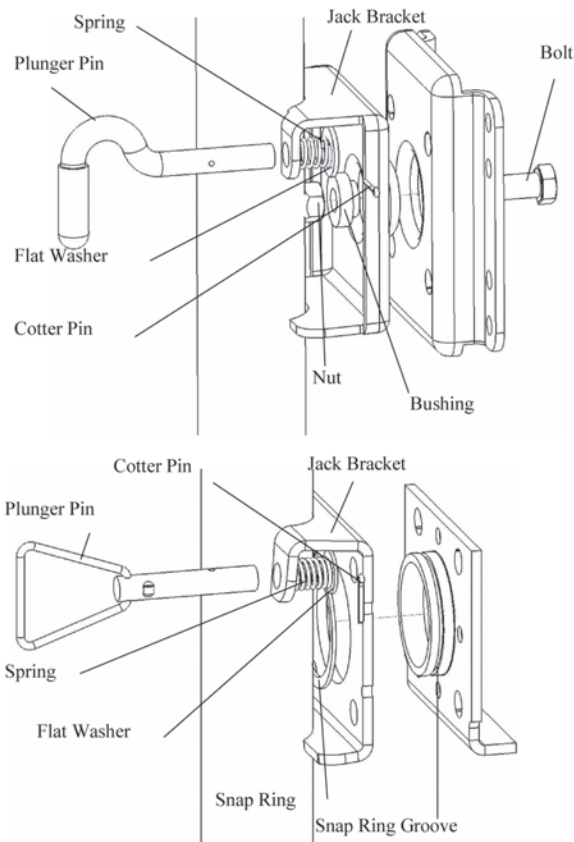
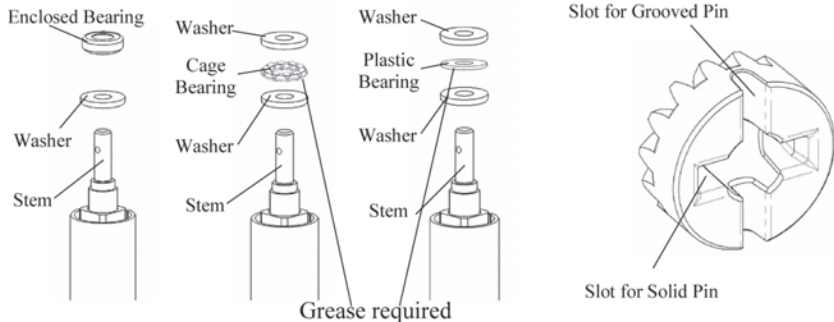

Bolt-Thru Assembly:

Place the jack bracket into the recessed opening of the mount. Place the small end of the bushing into the jack bracket and onto the bolt. Tighten until there is little movement in the bushing.

Snap Ring Assembly:

Place the jack bracket over the mount so that the snap ring groove is reachable on the inside of the jack bracket. Insert the snap ring into the groove. Be sure the snap ring is fully seated in the groove.

Plunger Pin Assembly:

First select the appropriate hole for the plunger pin. When viewing the jack from the crank side, 3/8" pins fit into the left hole, 1/2" plunger pins fit into the right hole. Also check that the mating bracket has the correct size holes in it.

- 1) Start the plunger pin through the jack bracket and place the spring and washer on the plunger pin before fully inserting the plunger pin through the jack bracket.
- 2) The spring and washer must be compressed to allow the cotter pin to be properly inserted into the plunger pin.
- 3) Be sure the jack is assembled properly and functions as new before bending the cotter pin to secure the plunger pin assembly and before using it to support a load.

ELECTRIC WINCH PERFORMANCE DATA AND DIMENSIONS

DC6000 - 6,000 LBS.

>>> PERFORMANCE DATA

LINE SPEED AND AMP. DRAW

LINE PULL LB / KG	SPEED FPM / MPM	12V AMPS
NO LOAD	26.2 / 8.0	60
2,000 / 907	17 / 5.2	150
4,000 / 1,814	10.2 / 3.1	240
6,000 / 2,722	6.5 / 2	300

LINE PULL AND ROPE CAPACITY

LAYER OF ROPE	PULL BY LAYER LB / KG	TOTAL ROPE ON DRUM FT / M
1st	6,000 / 2,722	12.5 / 3.8
2nd	4,995 / 2,266	27.5 / 8.4
3rd	4,279 / 1,941	45 / 13.7
4th	3,742 / 1,698	65.1 / 19.8

>>> DIMENSIONS

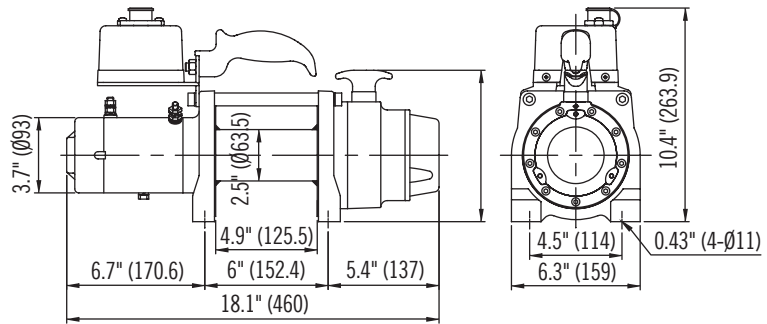

DC9000 - 9,000 LBS.

>>> PERFORMANCE DATA

LINE SPEED AND AMP. DRAW

LINE PULL LB / KG	SPEED FPM / MPM	12V AMPS
NO LOAD	44 / 13.4	55
2,000 / 907	15 / 4.6	110
4,000 / 1,814	11 / 3.4	200
6,000 / 2,722	9 / 2.7	230
9,000 / 4,082	6.4 / 2	350

LINE PULL AND ROPE CAPACITY

LAYER OF ROPE	PULL BY LAYER LB / KG	TOTAL ROPE ON DRUM FT / M
1st	9,000 / 4,083	17.7 / 5.4
2nd	7,310 / 3,316	40 / 12.2
3rd	6,154 / 2,792	67.3 / 20.5
4th	5,314 / 2,410	82 / 25

>>> DIMENSIONS

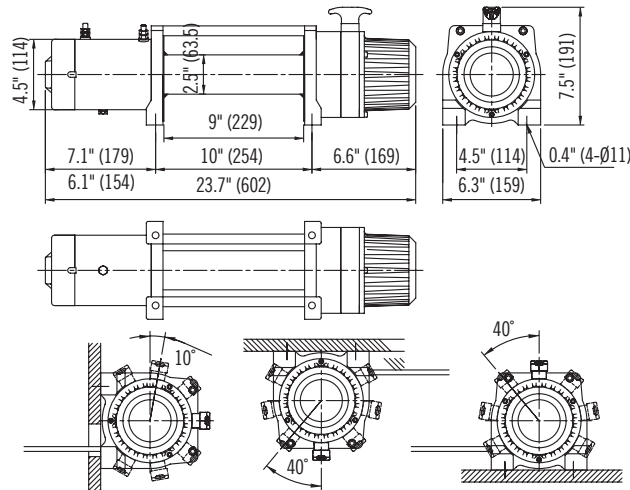

DC12000L - 12,000 LBS. LIGHT

>>> PERFORMANCE DATA

LINE SPEED AND AMP. DRAW

LINE PULL LB / KG	SPEED FPM / MPM	12V AMPS
NO LOAD	26.2 / 8	50
4,000 / 1,814	9.8 / 3	120
8,000 / 3,629	5 / 1.5	230
10,000 / 4,536	4 / 1.2	290
12,000 / 5,443	3.3 / 1	350

LINE PULL AND ROPE CAPACITY

LAYER OF ROPE	PULL BY LAYER LB / KG	TOTAL ROPE ON DRUM FT / M
1st	12,000 / 5,443	17.7 / 5.4
2nd	9,522 / 4,319	40 / 12.2
3rd	7,893 / 3,580	67.3 / 20.5
4th	6,737 / 3,055	82 / 25

>>> DIMENSIONS

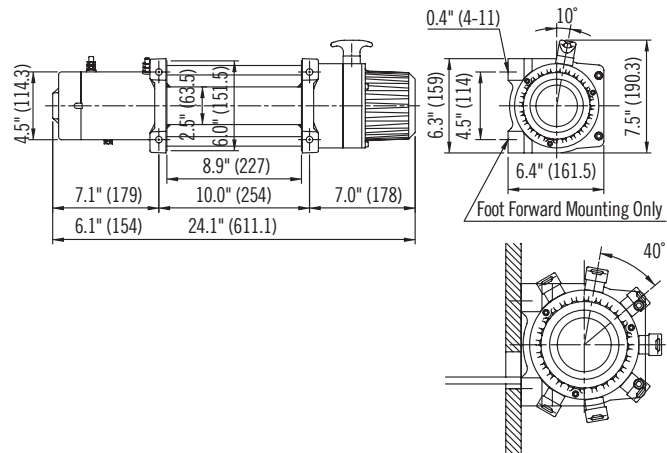

DC12000 - 12,000 LBS.

>>> PERFORMANCE DATA

LINE SPEED AND AMP. DRAW

LINE PULL LB / KG	SPEED FPM / MPM	12V AMPS
NO LOAD	27 / 8.3	60
4,000 / 1,814	8.6 / 2.6	200
8,000 / 3,629	5.8 / 1.7	310
10,000 / 4,536	4.4 / 1.4	370
12,000 / 5,443	4 / 1.2	440

LINE PULL AND ROPE CAPACITY

LAYER OF ROPE	PULL BY LAYER LB / KG	TOTAL ROPE ON DRUM FT / M
1st	12,000 / 5,443	21.5 / 6.6
2nd	10,060 / 4,563	47.2 / 14.4
3rd	8,659 / 3,928	77 / 23.5
4th	7,601 / 3,448	110.9 / 33.8
5th	6,774 / 3,073	125 / 58

>>> DIMENSIONS

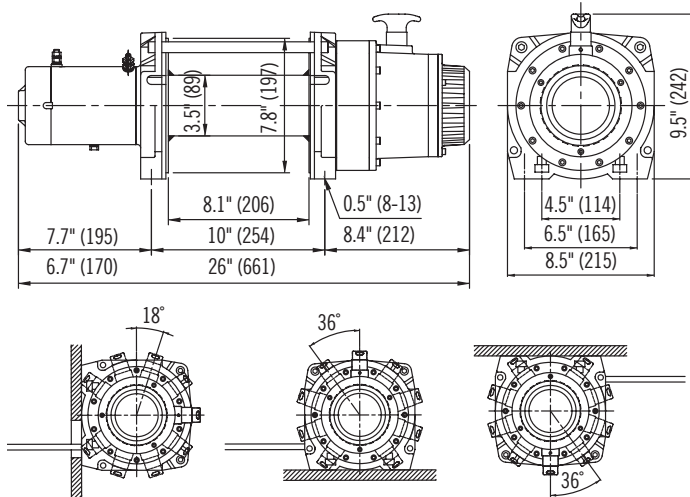

DC15000 - 15,000 LBS.

>>> PERFORMANCE DATA

LINE SPEED AND AMP. DRAW

LINE PULL LB / KG	SPEED FPM / MPM	12V AMPS
NO LOAD	22 / 6.9	60
4,000 / 1,814	5.4 / 1.6	180
8,000 / 3,629	3.8 / 1.2	280
12,000 / 5,443	2.9 / 0.9	385
15,000 / 6,803	2.5 / 0.8	460

LINE PULL AND ROPE CAPACITY

LAYER OF ROPE	PULL BY LAYER LB / KG	TOTAL ROPE ON DRUM FT / M
1st	15,000 / 6,804	18.6 / 5.7
2nd	12,277 / 5,569	41.4 / 12.6
3rd	10,391 / 4,713	68.3 / 20.8
4th	9,007 / 4,086	89 / 27

>>> DIMENSIONS

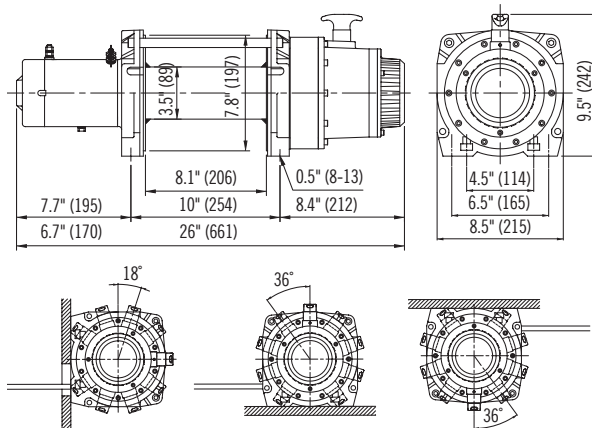

DC18000 - 18,000 LBS.

>>> PERFORMANCE DATA

LINE SPEED AND AMP. DRAW

LINE PULL LB / KG	SPEED FPM / MPM	24V AMPS
NO LOAD	28.2 / 8.6	40
8,000 / 3,629	12.0 / 3.6	140
12,000 / 5,443	9.3 / 2.8	210
15,000 / 6,803	7.5 / 2.3	260
18,000 / 8,164	3.3 / 1	320

LINE PULL AND ROPE CAPACITY

LAYER OF ROPE	PULL BY LAYER LB / KG	TOTAL ROPE ON DRUM FT / M
1st	18,000 / 8,165	15.4 / 4.7
2nd	14,431 / 6,546	34.4 / 10.5
3rd	12,028 / 5,455	57.4 / 17.5
4th	10,311 / 4,677	82 / 25

>>> DIMENSIONS

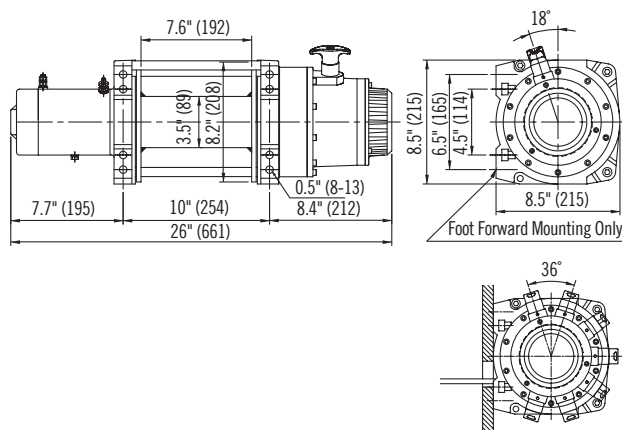

DC2500 - 2,500 LBS.

>>> PERFORMANCE DATA

LINE SPEED AND AMP DRAW

LINE PULL LB / KG	LINE SPEED FPM / MPM	AMP DRAW
NO LOAD	16.4 / 5	30
1,000 / 454	11 / 3.5	80
2,000 / 907	7.5 / 2.3	150
2,500 / 1,134	4.2 / 1.3	200

LINE PULL AND ROPE CAPACITY

LAYER OF ROPE	PULL BY LAYER LB / KG	TOTAL ROPE ON DRUM FT / M
1st	2,500 / 1,134	10.2 / 3.1
2nd	2,149 / 975	22 / 6.7
3rd	1,885 / 855	35.5 / 10.8
4th	1,678 / 761	50 / 15.2

>>> DIMENSIONS

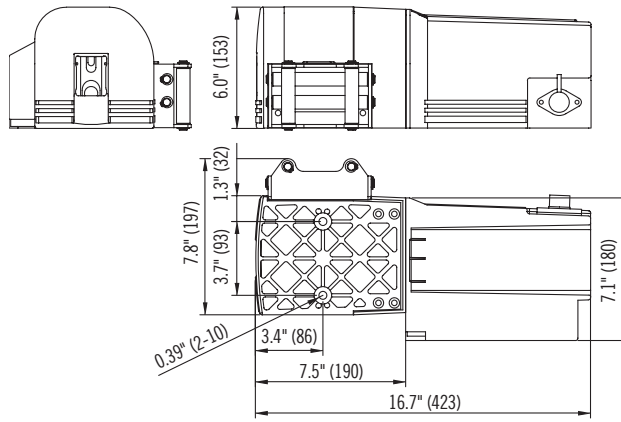

DC3500 - 3,500 LBS.

>>> PERFORMANCE DATA

LINE SPEED AND AMP DRAW

LINE PULL LB / KG	LINE SPEED FPM / MPM	AMP DRAW
NO LOAD	21.3 / 6.5	25
1,000 / 454	16.4 / 5	110
2,000 / 907	11.8 / 3.6	200
2,500 / 1,134	10.5 / 3.2	230
3,000 / 1,361	8.2 / 2.5	260
3,500 / 1,588	5.9 / 1.8	300

LINE PULL AND ROPE CAPACITY

LAYER OF ROPE	PULL BY LAYER LB / KG	TOTAL ROPE ON DRUM FT / M
1st	3,500 / 1,588	8.9 / 2.7
2nd	2,954 / 1,340	19.6 / 6
3rd	2,555 / 1,159	31.8 / 9.7
4th	2,251 / 1,021	45.7 / 13.9
5th	2,012 / 913	50 / 15.2

>>> DIMENSIONS

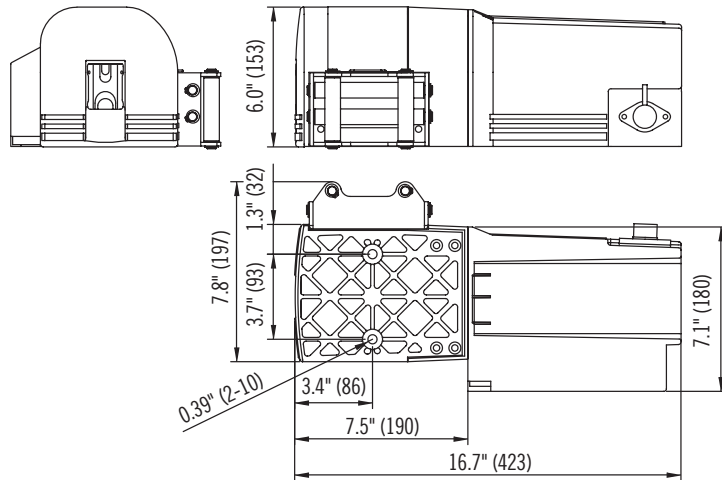

DC4500 - 4,500 LBS.

>>> PERFORMANCE DATA

LINE SPEED AND AMP DRAW

LINE PULL LB / KG	LINE SPEED FPM / MPM	AMP DRAW
NO LOAD	21.3 / 6.5	25
1,000 / 454	16.4 / 5	110
2,000 / 907	11.8 / 3.6	210
2,500 / 1,134	10.5 / 3.2	240
3,000 / 1,361	8.2 / 2.5	270
3,500 / 1,588	5.9 / 1.8	290
4,000 / 1,814	4.6 / 1.4	310
4,500 / 2,041	1.3 / .4	330

LINE PULL AND ROPE CAPACITY

LAYER OF ROPE	PULL BY LAYER LB / KG	TOTAL ROPE ON DRUM FT / M
1st	4,500 / 2,041	7.9 / 2.4
2nd	3,722 / 1,688	17.4 / 5.3
3rd	3,174 / 1,440	28.6 / 8.7
4th	2,766 / 1,255	41.4 / 12.6
5th	2,451 / 1,112	50 / 15.2

>>> DIMENSIONS

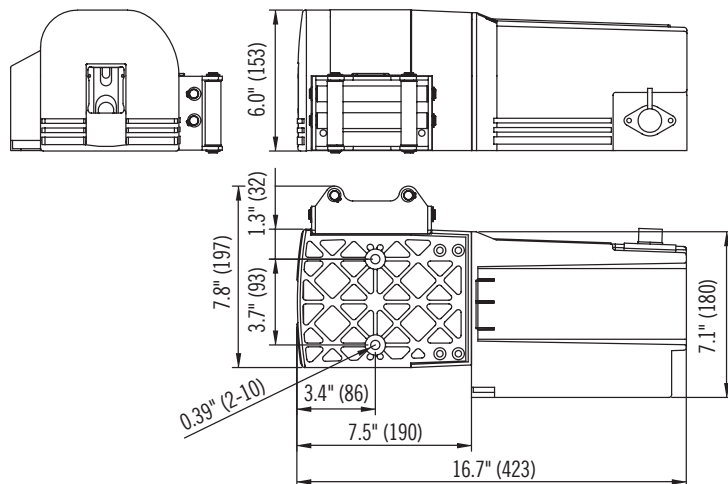

HYDRAULIC WINCH PERFORMANCE DATA AND DIMENSIONS

HW8000 - 8,000 LBS.

>>> PERFORMANCE DATA

LINE PULL AND ROPE CAPACITY			LINE SPEED
LAYER OF ROPE	PULL BY LAYER LB / KG	TOTAL ROPE ON DRUM FT / M	15.9 G / MIN (60 L/MIN) FPM/MPM
1st	8,000 / 3,630	25.6 / 7.8	49 / 15
2nd	6,669 / 3,025	56.1 / 17.1	59.7 / 18.2
3rd	5,717 / 2,593	91.9 / 28	69.8 / 21.2
4th	5,002 / 2,269	131 / 40	79.4 / 24.2

>>> DIMENSIONS

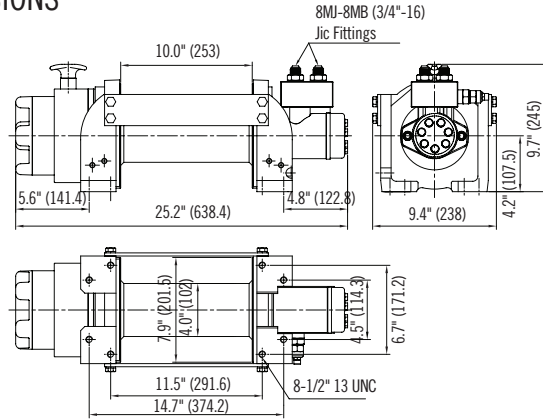

HW12000 - 12,000 LBS.

>>> PERFORMANCE DATA

LINE PULL AND ROPE CAPACITY			LINE SPEED
LAYER OF ROPE	PULL BY LAYER LB / KG	TOTAL ROPE ON DRUM FT / M	15.9 G / MIN (60 L/MIN) FPM/MPM
1st	12,000 / 5,440	23 / 7	36 / 11
2nd	10,075 / 4,570	50.9 / 15.5	43.3 / 13.2
3rd	8,684 / 3,939	25 / 82	51.2 / 15.6

>>> DIMENSIONS

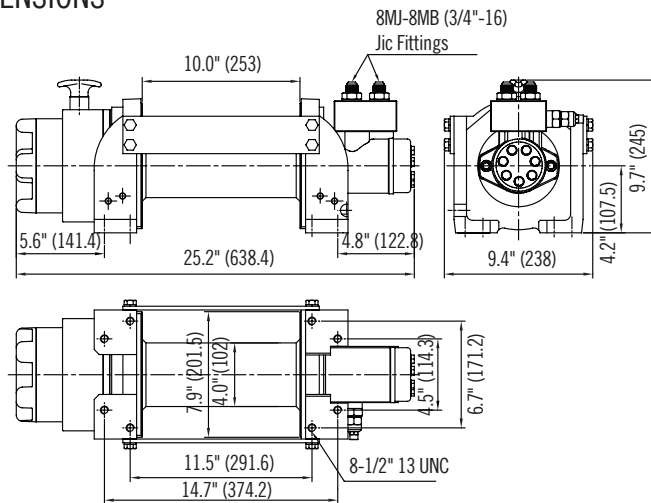

HW15000 - 15,000 LBS.

>>> PERFORMANCE DATA

LINE PULL AND ROPE CAPACITY			LINE SPEED
LAYER OF ROPE	PULL BY LAYER LB / KG	TOTAL ROPE ON DRUM FT / M	15.9 G / MIN (60 L/MIN) FPM/MPM
1st	15,000 / 6,800	23.3 / 7.1	30 / 9
2nd	12,273 / 5,567	51.5 / 15.7	35.8 / 10.9
3rd	10,390 / 4,713	25.9 / 85	42 / 12.8
4th	9,008 / 4,086	123.4 / 37.6	48.6 / 14.8
5th	7,950 / 3,606	165 / 50.3	55 / 16.8

>>> DIMENSIONS

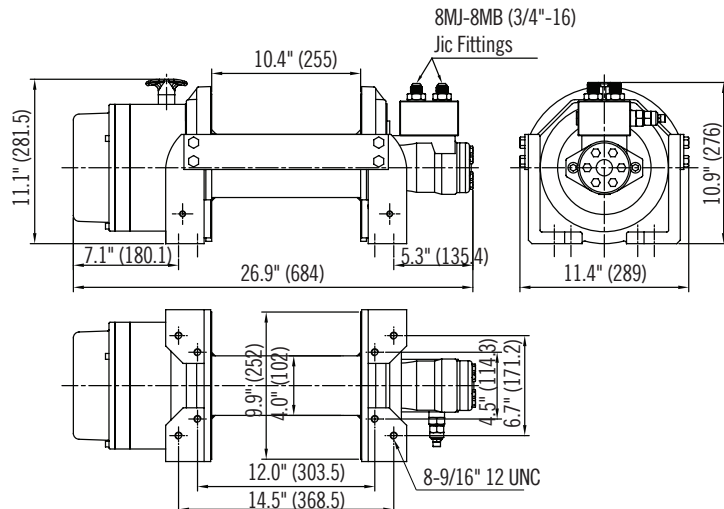

ELECTRIC HOIST PERFORMANCE DATA AND DIMENSIONS

DCH650 - 650 LBS.

>>> PERFORMANCE DATA

LINE SPEED AND AMP DRAW (first layer of wire rope on the drum)

1ST LAYER LINE PULL LB / KG	LINE SPEED FPM / MPM 12V	AMP DRAW 12V	% DUTY CYCLE MIN / 10 MIN
No Load	14.1 / 4.3	25	3.0
320 / 147	13.8 / 4.2	45	2.0
650 / 295	13.1 / 4.0	55	1.5

HOIST CAPACITY

ROPE LAYER	CAPACITY LB / KG	LINE SPEED FPM / MPM	LENGTH OF ROPE ON DRUM FT / M
1 ST	650 / 295	13.1 / 4.0	13.5 / 4.1
2 ND	586 / 266	14.8 / 4.5	28.5 / 8.7
3 RD	531 / 241	16 / 4.9	45.3 / 13.8
4 TH	487 / 221	17.7 / 5.4	60 / 18.3

>>> DIMENSIONS

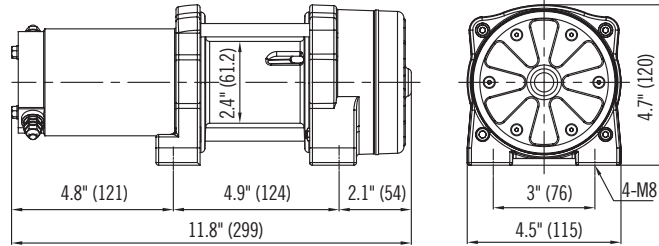

DCH800 - 800 LBS.

>>> PERFORMANCE DATA

LINE SPEED AND AMP DRAW (first layer of wire rope on the drum)

1ST LAYER LINE PULL LB / KG	LINE SPEED FPM / MPM 12V	AMP DRAW 12V	% DUTY CYCLE MIN / 10 MIN
No Load	11.8 / 3.6	20	3.0
400 / 184	11.2 / 3.4	40	2.0
800 / 362	10.5 / 3.2	55	1.5

HOIST CAPACITY

ROPE LAYER	CAPACITY LB / KG	LINE SPEED FPM / MPM	LENGTH OF ROPE ON DRUM FT / M
1 ST	800 / 362	10.5 / 3.2	21.7 / 6.6
2 ND	721 / 327	11.8 / 3.6	45.9 / 14
3 RD	655 / 297	12.8 / 3.9	60 / 18.3

>>> DIMENSIONS

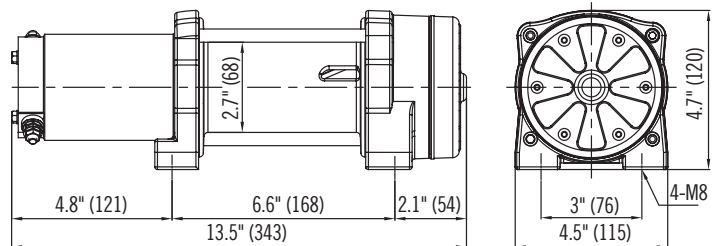

DCH1200 - 1,200 LBS.

>>> PERFORMANCE DATA

LINE SPEED AND AMP DRAW (first layer of wire rope on the drum)

1ST LAYER LINE PULL LB / KG	LINE SPEED FPM / MPM 12V	AMP DRAW 12V	% DUTY CYCLE MIN / 10 MIN
No Load	24.3 / 7.4	30	2.5
300 / 136	22.6 / 6.9	55	2.3
600 / 272	21 / 6.4	75	2.0
900 / 408	19.4 / 5.9	95	1.8
1,200 / 544	18 / 5.5	130	1.5

HOIST CAPACITY

ROPE LAYER	CAPACITY LB / KG	LINE SPEED FPM / MPM	LENGTH OF ROPE ON DRUM FT / M
1 ST	1,200 / 544	5.5 / 1.7	13.8 / 4.2
2 ND	1,089 / 494	19.9 / 6.1	28.9 / 8.8
3 RD	996 / 452	21.7 / 6.6	45.3 / 13.8
4 TH	917 / 416	23.6 / 7.2	60 / 18.3

>>> DIMENSIONS

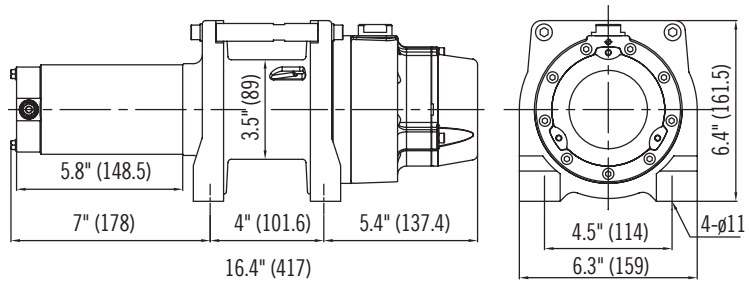

TRAILERS: FEDERAL LIGHTING EQUIPMENT LOCATION REQUIREMENTS

IMPORTANT NOTE: Every lamp, reflex reflector, and conspicuity treatment must be permanently attached in the location specified below and must comply with all applicable requirements prescribed for it by FMVSS/CMVSS 108. The face of any device on the front/rear and sides should be, respectively perpendicular and parallel to the vehicle's centerline, unless it is photometrically certified at installa-

tion angle. No part of the vehicle shall prevent any device from meeting its prescribed requirements unless an auxiliary device meeting all prescribed requirements is installed. In Canada: Manufacturers and importers of vehicles must have the proper certification test records demonstrating compliance of lighting components with all prescribed requirements.

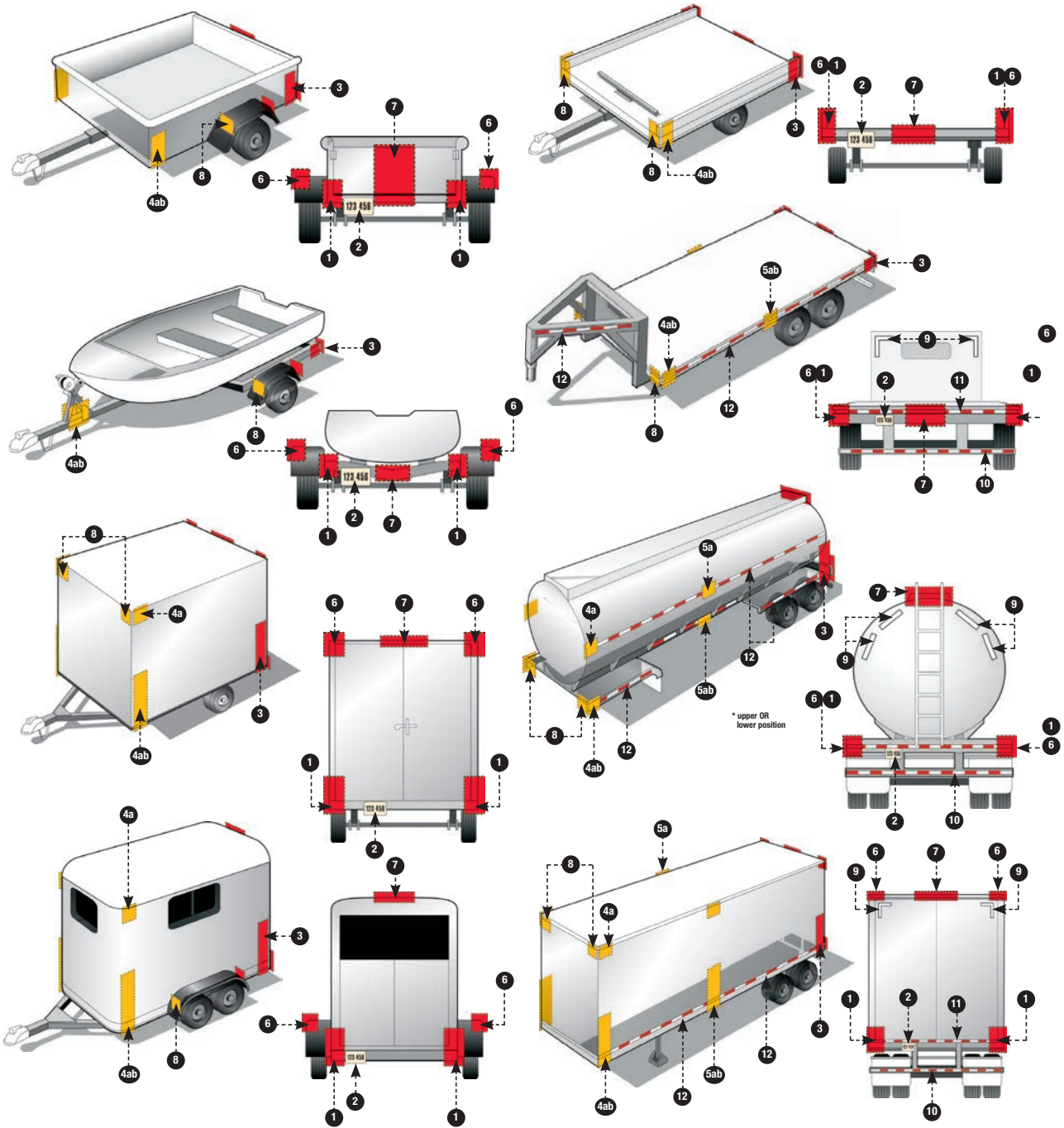

This table summarizes lighting equipment requirements contained in Federal/Canada Motor Vehicle Safety Standard 108. While Horizon Global believes this to be an accurate summary of the latest printed information, the actual standard should be consulted for design or other such purposes. For complete compliance requirements consult Title 49 - Code of Federal Regulations-Section 571.108 (USA) or Section 108 of the Motor Vehicle Safety Regulations (Canada). State or Provincial regulations, where they may apply, have not been included.

TRAILERS: FEDERAL LIGHTING EQUIPMENT LOCATION REQUIREMENTS (CONTINUED)

BASIC EQUIPMENT REQUIRED ON ALL TRAILERS

DESCRIPTION				MANDATORY REQUIREMENTS			
Area	Equipment	SAE Lens Coding	Functional Purpose	Quantity	Color	Location	Height mm(in.) from the ground
1	Tail Lamps	(T)	Indicate vehicle's presence and width	Minimum 2	Red	On the rear - symmetrical as far apart as practicable	380-1830 (15-72)
	Stop Lamps	(S)	Indicate braking	Minimum 2	Red	On the rear - symmetrical as far apart as practicable	380-1830 (15-72)
	Rear Turn Signal Lamps	(I)	Indicate direction of turn	Minimum 2	Red or Yellow	On the rear - symmetrical as far apart as practicable	380-2110 (15-83)
	Rear Reflex Reflectors	(A)	Indicate vehicle's presence and width	Minimum 2	Red	On the rear - symmetrical as far apart as practicable facing rearward	380-1530 (15-60)
2	License Plate Lamp(s)	(L)	Illuminates license plate	Minimum 1	White	On the rear - above or at the sides of license plate	No requirement
3	Rear Side Marker Lamps <small>*photometrically certified at installation angle</small>	(P2, PC* or P3, PC2*)	Front and rear side marker lamps / side reflex reflectors indicate vehicle's presence and length	Minimum 2	Red	Each side at rear as far back as practicable	380-1530 (15-60) no max. for veh. under 2032mm (80") wide
	Rear Side Reflex Reflectors	(A)		Minimum 2	Red facing sideward	Each side at rear as far back as practicable	380-1530 (15-60)
4	a Front Side Marker Lamps <small>*photometrically certified at installation angle</small>	(P2, PC* or P3, PC2*)	Front and rear side marker lamps / side reflex reflectors indicate vehicle's presence and length	Minimum 2	Yellow	Each side at front as far forward as practicable	380 (15) minimum
	b Front Side Reflex Reflectors	(A)		Minimum 2	Yellow	Each side at front as far forward as practicable facing sideward	380-1530 (15-60)

ADDITIONAL EQUIPMENT FOR TRAILERS EXCEEDING THE FOLLOWING PARAMETERS

Length 9.1m (30 ft.) or longer

DESCRIPTION				MANDATORY REQUIREMENTS			
Area	Equipment	SAE Lens Coding	Functional Purpose	Quantity	Color	Location	Height mm(in.) from the ground
5	a Intermediate Side Marker Lamps	(P2 or P3)	Indicate presence of a long vehicle	Minimum 2	Yellow	Each side near center facing sideward	380 (15) minimum
	b Intermediate Side Reflex Reflectors	(A)	Indicate presence of a long vehicle	Minimum 2	Yellow	Each side near center facing sideward	380-1530 (15-60)

Width 2032mm (80 in.) or wider

DESCRIPTION			MANDATORY REQUIREMENTS				
Area	Equipment	SAE Lens Coding	Functional Purpose	Quantity	Color	Location	Height
6	Rear Clearance Lamps <small>*photometrically certified at installation angle with tail lamps</small>	(P2, PC* or P3, PC2*)	Show vehicle's width MAY NOT be combined	Minimum 2	Red	At widest point - symmetrical on the rear or near the rear ID lamps are at the top facing rearward	As high as practicable may be lower only if
7	Rear Identification (ID) Lamps	(P2 or P3)	Indicate presence of a wide vehicle	Exactly 3	Red	On the rear - center horizontally spaced 150mm (6 in.) to 300mm (12 in.) apart facing rearward	At the top - may be lower if door header narrower than 25mm
8	Front Clearance Lamps <small>*photometrically certified at installation angle</small>	(P2, PC* or P3, PC2*)	Show vehicle's width	Minimum 2	Yellow	At widest point - symmetrical on the front or near the front facing forward	As high as practicable

Width 2032mm (80 in.) or wider AND GVWR 4536 kg (10,000 lb.) or more

DESCRIPTION			MANDATORY REQUIREMENTS				
Area	Conspicuity Treatment	DOT Coding	Quantity	Color	Location	Height	Options
9	Rear Upper Body Markings		Exactly 2 pairs of 300mm long strips	White	On the rear upper corners facing rearward	At the top	
10	Bumper Bar Marking	DOT-C DOT-C2 DOT-C3 DOT-C4	Continuous	Red/White	On the rear bumper bar's horizontal element full width - facing rearward	No requirement	
11	Rear Lower Body Marking		Continuous	Red/White (see options)	On the rear full width of the vehicle facing rearward	As horizontal as practicable and as close as practicable to the range of 375 to 1525mm from the ground	
12	Side Marking		(see location)	Red/White (see options)	Each side - facing sideward continuous, or evenly spaced over minimum of 50% of length starts and ends as close to the front and rear of the vehicle as practicable	As horizontal as practicable and as close as practicable to the range of 375 to 1525mm from the ground	

NOTE: The edge of red conspicuity tape shall not be closer than 75 mm to the edge of any amber lamp and the edge of white conspicuity tape shall not be closer than 75 mm to the edge of any lamp

TRUCKS: FEDERAL LIGHTING EQUIPMENT LOCATION REQUIREMENTS

IMPORTANT NOTE: Every lamp, reflex reflector, and conspicuity treatment must be permanently attached in the location specified below and must comply with all applicable requirements prescribed for it by FMVSS/CMVSS 108. The face of any device on the front/rear and sides should be, respectively perpendicular and parallel to the vehicle's centerline, unless it is photometrically

certified at installation angle. No part of the vehicle shall prevent any device from meeting its prescribed requirements unless an auxiliary device meeting all prescribed requirements is installed. In Canada: Manufacturers and importers of vehicles must have the proper certification test records demonstrating compliance of lighting components with all prescribed requirements.

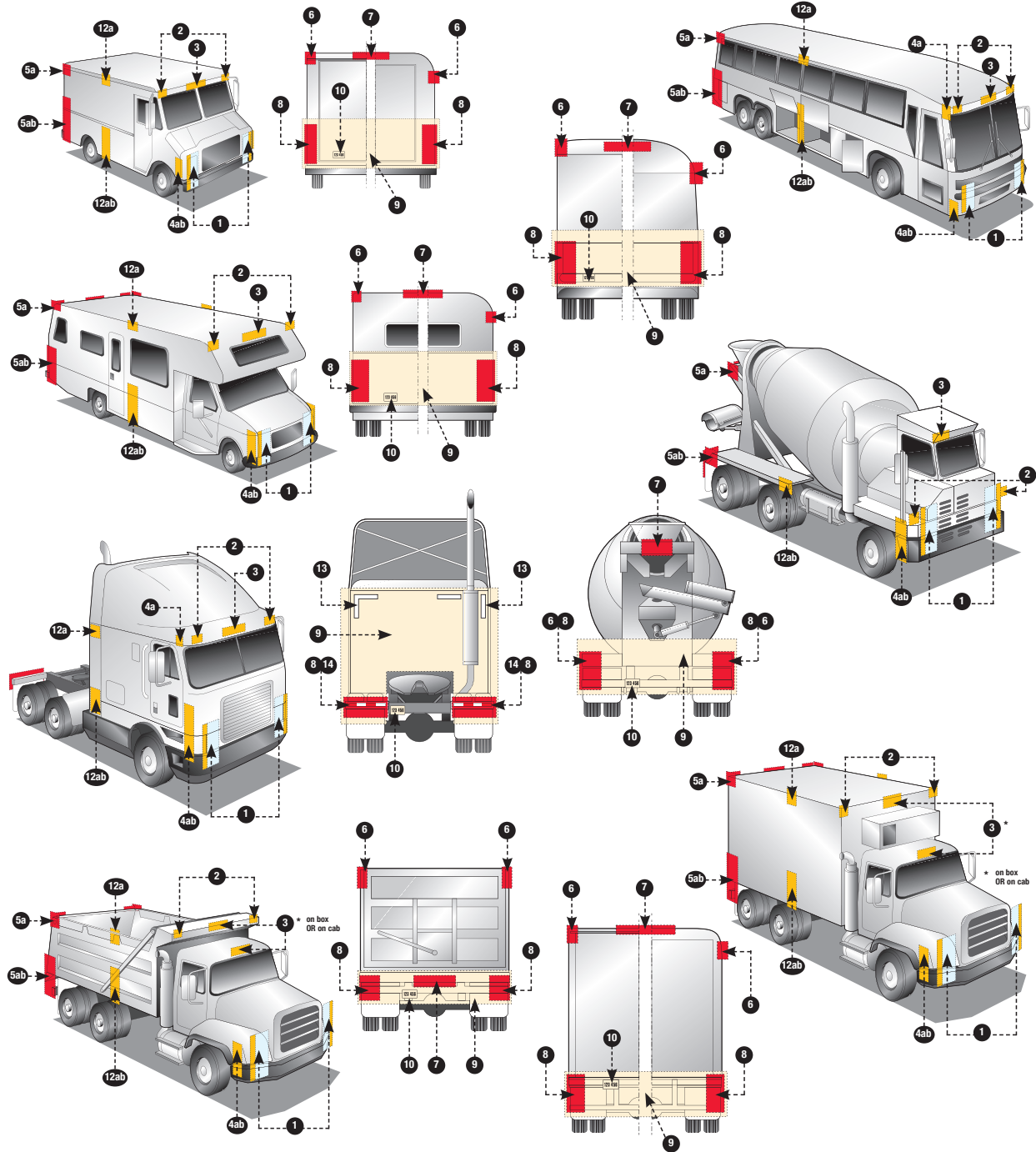

This table summarizes lighting equipment requirements contained in Federal/Canada Motor Vehicle Safety Standard 108. While Horizon Global believes this to be an accurate summary of the latest printed information, the actual standard should be consulted for design or other such purposes. For complete compliance requirements consult Title 49 - Code of Federal Regulations-Section 571.108 (USA) or Section 108 of the Motor Vehicle Safety Regulations (Canada). State or Provincial regulations, where they may apply, have not been included.

TRUCKS: FEDERAL LIGHTING EQUIPMENT LOCATION REQUIREMENTS (CONTINUED)

BASIC EQUIPMENT REQUIRED ON ALL TRUCKS, BUSES & MPVs

DESCRIPTION				MANDATORY REQUIREMENTS			
Area	Equipment	SAE Lens Coding	Functional Purpose	Quantity	Color	Location	Height mm(in.) from the ground
1	Headlamps - Lower Beam US requires "DOT" lettering on lens US&Canada - light source code required on lens	(H, HR)	Forward road illumination	Minimum 2	White	On the front - symmetrical as far apart as practicable If 4 lamp system - outboard or above upper beams	560-1370 (22-54)
	Headlamps - Upper Beam US requires "DOT" lettering on lens US&Canada - light source code required on lens	(H, HR)	Forward road illumination	Minimum 2	White	On the front - symmetrical If 4 lamp system - inboard or below lower beams	560-1370 (22-54)
	Parking Lamps Vehicles less than 2032mm wide	(P)	Indicate parked vehicle	Minimum 2	White or Yellow	On the front - symmetrical as far apart as practicable	380-1830 (15-72)
	Daytime Running Lamps (DRL) Canada - required / US - option US requires "DRL" lettering on lens if not headlamp	(Y2)	Indicate in use vehicle	Minimum 2	White or Yellow	On the front - symmetrical as far apart as practicable on type of DRL	380 (15) min. Max. depends
	Front Turn Signal/Hazard Warning Lamps	(I)	Indicate direction of turn/identify disabled vehicle	Minimum 2	Yellow	On the front - symmetrical as far apart as practicable	380-2110 (15-83)
2	Front Clearance Lamps Vehicles 2032mm wide or wider *photometrically certified at installation angle	(P2, PC* or P3, PC2*)	Show vehicle's width	Minimum 2	Yellow	At widest point - symmetrical on the front or near the front facing forward	As high as practicable
3	Front Identification Lamps (ID) Vehicles 2032mm wide or wider	(P2 or P3)	Indicate presence of a wide vehicle	Exactly 3	Yellow	On the front - center horizontally spaced 150 mm (6 in.) to 300 mm (12 in.) apart	As high as practicable or on top of the cab
4	a Front Side Marker Lamps *photometrically certified at installation angle	(P2, PC* P3, PC2*)	Front and rear side marker lamps / side reflex reflector indicate vehicle's presence and length	Minimum 2	Yellow	Each side at front as far forward as practicable	380 (15) minimum
	b Front Side Reflex Reflectors	(A)		Minimum 2	Yellow	Each side at front as far forward as practicable facing sideward	380-1530 (15-60)
5	a Rear Side Marker Lamps ** *photometrically certified at installation angle	(P2, PC* or P3, PC2*)		Minimum 2	Red	Each side at rear as far back as practicable	380 (15) minimum
	b Rear Side Reflex Reflectors ** **not required on Truck Tractors	(A)		Minimum 2	Red	Each side at rear as far back as practicable facing sideward	380-1530 (15-60)
6	Rear Clearance Lamps Vehicles 2032mm wide or wider Not required on Truck Tractors *photometrically certified at installation angle	(P2, PC* or P3, PC2*)	Show vehicle's width MAY NOT be combined with tail lamps	Minimum 2	Red	At widest point - symmetrical on the rear or near the rear facing rearward	As high as practicable may be lower only if rear ID lamps are at the top
7	Rear Identification (ID) Lamps Vehicles 2032mm wide or wider Not required on Truck Tractors	(P2 or P3)	Indicate presence of a wide vehicle	Exactly 3	Red	On the rear - center horizontally spaced 150mm (6 in.) to 300mm (12 in.) apart facing rearward	At the top may be lower if doo narrower than 25mm
8	Tail Lamps	(T)	Indicate vehicle's presence and width	Minimum 2	Red	On the rear - symmetrical as far apart as practicable	380-1830 (15-72)
	Stop Lamps	(S)	Indicate braking	Minimum 2	Red	On the rear - symmetrical as far apart as practicable	380-1830 (15-72)
	Rear Turn Signal/Hazard Warning Lamps	(I)	Indicate direction of turn/identify disabled vehicle	Minimum 2	Red or yellow	On the rear - symmetrical as far apart as practicable	380-2110 (15-83)
	Rear Reflex Reflectors	(A)	Show vehicle's presence and width	Minimum 2	Red	On the rear - symmetrical as far apart as practicable	380-1530 (15-60)
9	Backup Lamp	(R)	Illuminates ground behind the vehicle and alert road users	Minimum 1	White	Rear	No requirement
10	License Plate Lamp(s)	(L)	Illuminates license plate	Minimum 1	White	On the rear - above or at the sides of license plate	No requirement
11	Center High Mounted Stop Lamp Vehicles less than 2032mm wide and 4536kg	(U3)	Indicates braking	1	Red	On the rear - centerline of the vehicle	860 (34) minimum

ADDITIONAL EQUIPMENT FOR SPECIFIC VEHICLES VEHICLES 9.1m (30 ft.) LONG OR LONGER

DESCRIPTION				MANDATORY REQUIREMENTS			
Area	Equipment	SAE Lens Coding	Functional Purpose	Quantity	Color	Location	Height mm(in.) from the ground
12	a Intermediate Side Marker Lamps	(P2 or P3)	Indicate presence of a long vehicle	Minimum 2	Yellow	Each side near center	380 (15) minimum
	b Intermediate Side Reflex Reflectors	(A)	Indicate presence of a long vehicle	Minimum 2	Yellow	Each side near center facing sideward	380-1530 (15-60)

Truck Tractors

DESCRIPTION		MANDATORY REQUIREMENTS					
Area	Conspicuity Treatment	DOT Coding	Quantity	Color	Location	Height	Options
13	Rear Upper Body Markings	DOT-C DOT-C2 DOT-C3 DOT-C4	Exactly 2 pairs of 300mm long strips	White	Rear upper corners of cab facing rearward	As high as practicable excluding fairings	
14	Rear Marking		Exactly 2 sections of min. 600mm each	Red/White	Rear - facing rearward - on fenders, on mud flap brackets, or within 300mm below the top of mud flaps	As horizontal as practicable and not higher than 1525mm from the ground	If mud flaps not used - on the cab or frame mounted brackets

NOTE: The edge of red conspicuity tape shall not be closer than 75 mm to the edge of any amber lamp and the edge of white conspicuity tape shall not be closer than 75 mm to the edge of any lamp

STANDARD AG IMPLEMENT ENHANCED LIGHTING SCHEME

Under both the standard and enhanced lighting schemes, when traveling straight forward, the amber (outside) lights flash in unison with the tractor's amber lights on the high intensity at approximately 100 pulses per minute, and the low intensity of the red (inside) lights are on constantly.

With the standard wire harness in place, when a turn is being signaled, the amber light signaling the turn will increase flashing to approximately 120 pulses per minute with the amber light on the opposite side changing to a constant high intensity light. This mirrors the amber light on the tractor. Both red lights, however, remain on a constant low intensity.

To meet the enhanced lighting standard, introduce Electronic AG Light Enhanced Module to the implement's wire harness, and simply add red lights that have an active high intensity along with an additional RH and LH wire to these red lights. With this enhanced AG lighting system, during a turn the red light next to the amber turn side light will rapidly flash on the high intensity in unison with the amber light, and the red light on the opposite side will remain constant on the high intensity. This is a dramatic safety feature to better signal (to everyone) turns by tractors and implements.

AG LIGHTING WIRING DIAGRAM

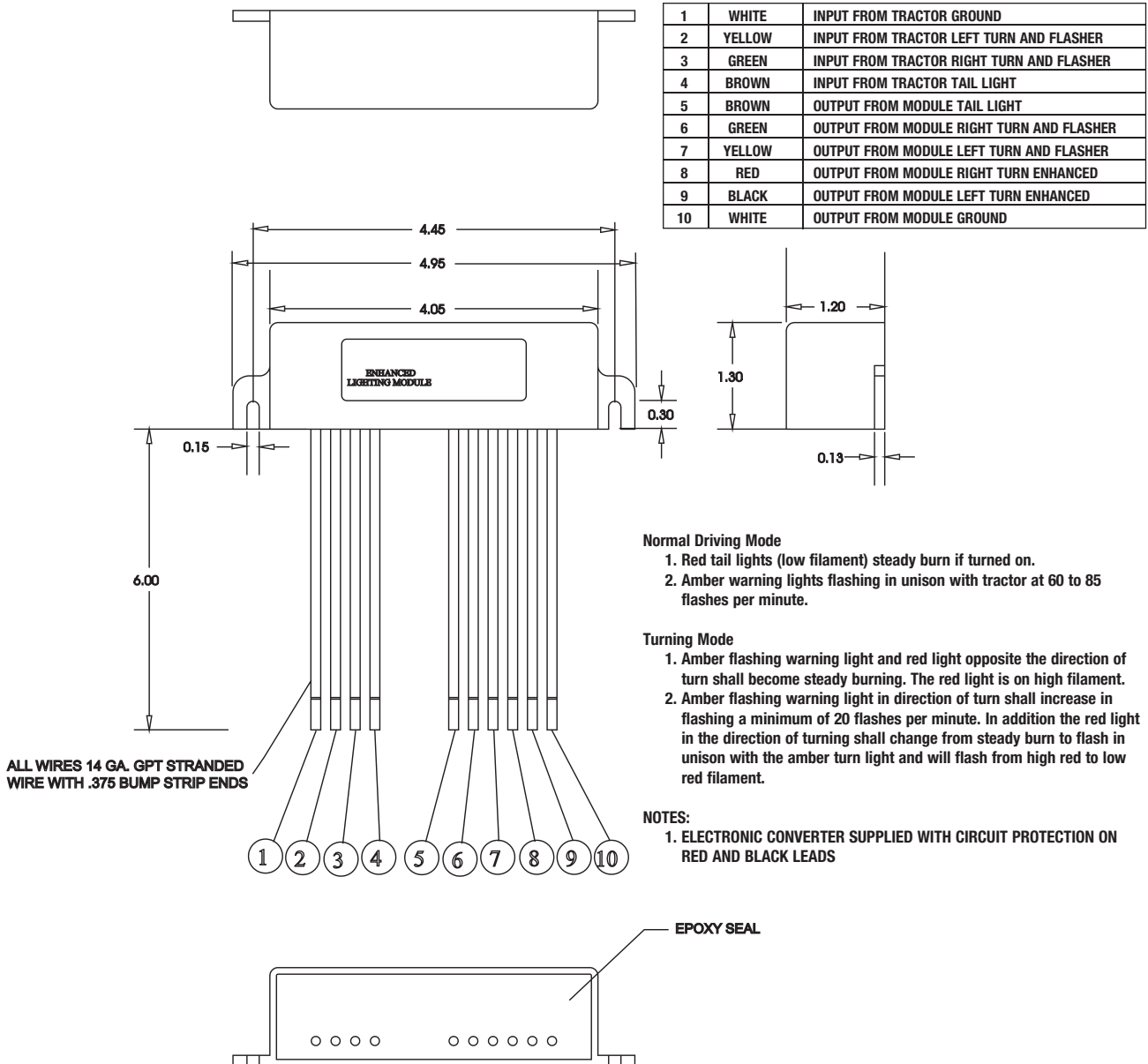

AG LIGHTING WIRING DIAGRAM WITH BRAKE

1	WHITE	INPUT FROM TRACTOR GROUND
2	RED	INPUT FROM TRACTOR BRAKE SIGNAL
3	YELLOW	INPUT FROM TRACTOR LEFT TURN AND FLASHER
4	GREEN	INPUT FROM TRACTOR RIGHT TURN AND FLASHER
5	BROWN	INPUT FROM TRACTOR TAIL LIGHT
6	BROWN	OUTPUT FROM MODULE TAIL LIGHT
7	GREEN	OUTPUT FROM MODULE RIGHT TURN AND FLASHER
8	YELLOW	OUTPUT FROM MODULE LEFT TURN AND FLASHER
9	RED	OUTPUT FROM MODULE RIGHT TURN ENHANCED & BRAKE SIGNAL
10	BLACK	OUTPUT FROM MODULE LEFT TURN ENHANCED & BRAKE SIGNAL
11	WHITE	OUTPUT FROM MODULE GROUND

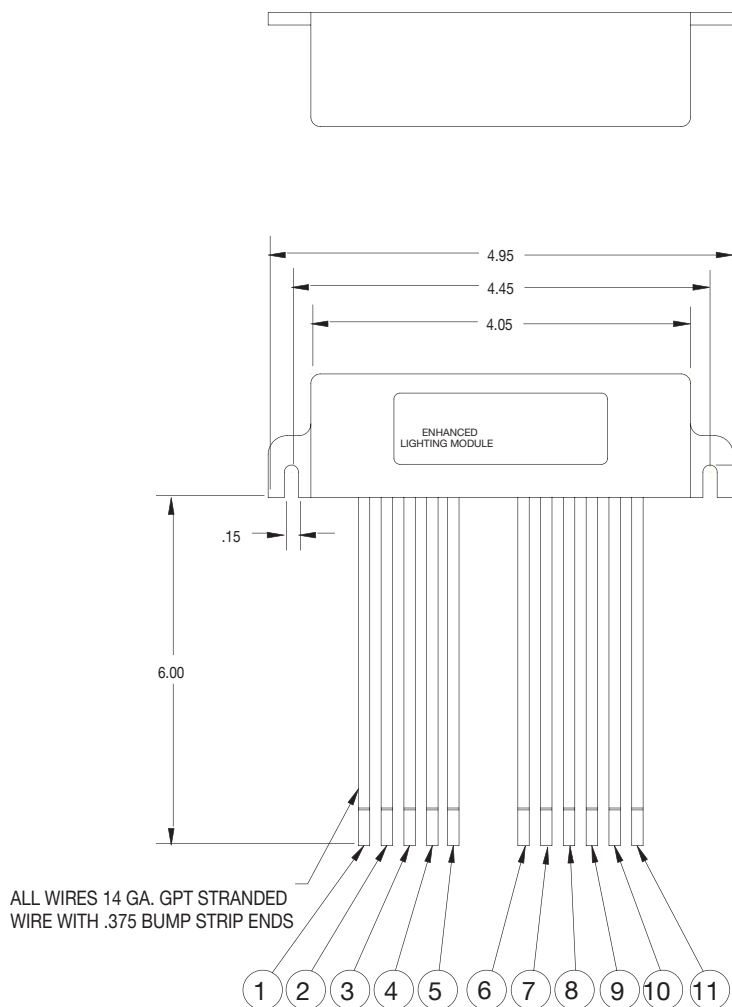

Normal Driving Mode

1. Red tail lights (low filament) steady burn if turned on.
2. Amber warning lights flashing in unison with tractor at 60 to 85 flashes per minute, controlled by flasher in tractor.
3. Red stop lights (High Filament) steady burn if the brake is applied.

Turning Mode

1. Amber flashing warning light and red light opposite the direction of turn shall become steady burning. The red light is on high filament.
2. Amber flashing warning light in direction of turn shall increase in flashing a minimum of 20 flashes per minute. In addition the red lamp in the direction of turning shall change from steady burn to flash in unison with the amber turn light and will flash from high red to low red filament.
3. If brake is applied during turning mode there will be no change in the state of the light; hence turning mode overrides brake signal.

NOTES:

1. ELECTRONIC CONVERTER SUPPLIED WITH CIRCUIT PROTECTION ON RED AND BLACK LEADS

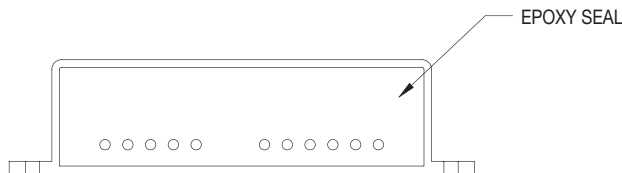

TECHNICAL INFORMATION IS CURRENT AS OF THE PRINTING OF THIS CATALOG. CONTACT TECHNICAL SERVICE FOR PERIODIC UPDATES.

AGRICULTURAL LIGHTING INFORMATION



TECHNICAL INFORMATION IS CURRENT AS OF THE PRINTING OF THIS CATALOG. CONTACT TECHNICAL SERVICE FOR PERIODIC UPDATES.

AG LIGHTS

Meet lighting standards for agricultural field equipment and improve highway operating safety easily and cost effectively with AG Lights by Cequent™. No other lighting package offers you the quality and dependability of AG Lights by Cequent. Designed specifically for the agricultural industry, AG Lights by Horizon Global withstand the most rigorous field and environmental conditions for long life and wear without repair. A variety of mounts enable easy and quick placement on all towable field equipment – harvesters, field cultivators, tillage equipment, forage boxes, and more.

SAFETY IS KEY

Meet ASAE lighting recommendations for agricultural equipment and improve safety, while operating on highways easily and cost effectively, with AG Lights by Cequent. No other lighting package offers you the quality, durability, and reliability of AG Lights by Cequent. Designed specifically for the agricultural industry, these Heavy-Duty AG Lights, when combined with Cequent's AG Wiring, withstand the most rigorous field and environmental conditions for long life and wear.

DURABLE, DEPENDABLE CONSTRUCTION OF HEAVY-DUTY AG LIGHTS

- High-impact, glass-filled thermoplastic housings deflect objects away from the lens area and prevent them from damaging or dislodging the lights assembly.
- Acrylic lenses.
- All fasteners provided are coated to resist rust.
- Bulb replacement, if ever needed, is simple – uses readily available standard automotive #1157 bulbs.

USER-FRIENDLY DESIGN

- AG Harnesses are designed with a full-length ground circuit, from tractor to AG Lamp, assuring reliable and continuous operation.
- Each light's wiring is routed through a center port area, helping facilitate a variety of light placement.
- AG Lights by Horizon Global are available with a variety of connector options.
- Choose from mounting screws, bolts, or heavy-duty magnets to meet your mounting needs.

- All lighting units are designed for easy customer repairs... right in the field. Pry out lenses with flat screwdriver for easy access to, and replacement of, the #1157 bulb.
- Five distinctly different light styles to meet your performance and styling requirements.

ELECTRONIC ENHANCED AG LIGHTING MODULE

Cequent, known for innovation and product reliability, presents an electronic module to deliver the ASAE recommended "enhanced turn signal lighting" with conventional AG lights and a standard wiring scheme. This unit may be hard-wired into the AG lighting harness or coupled-in by use of a variety of plug assemblies.

Use of Cequent's electronic enhanced AG lighting module helps to meet the new ASAE standard cost effectively. It eliminates the need for special wedge-based bulbs and non-standard wire schemes to deliver the enhanced turn signal lighting called for by this ASAE standard.

Refer to the Standard AG Implement Enhanced Lighting Guide.

MULTIPLE MOUNTING OPTIONS

A variety of mounts enable suitable placement on tractors and all towable field equipment – harvesters, cultivators, tillage equipment, fertilizers, forage boxes, and more. Heavy-Duty AG Lights by Horizon Global have a patented design incorporating multiple mounting options and lighting combinations. Dual AG Light models provide amber flashing and turn indicators plus red tail light functions. Amber or red single lights provide maximum mount flexibility (vertically or horizontally) to meet applicable lighting requirements. All AG Lights by Cequent, except the grommated series, are equipped with an exclusive molded weather-resistant low profile tri-plug. Custom plug configurations are also available.

Additionally, an optional brake light function is available for dual light or single red-lensed models. This optional function is also needed on lights used with enhanced turn light systems. The brake light option is recommended when implements are to be towed by non-farm vehicles or tractors with brakes (brake lights).

AG SAFETY LIGHTING SYSTEMS

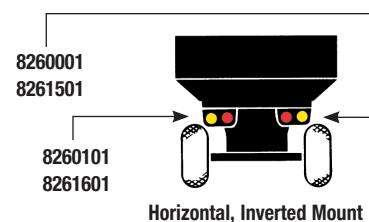
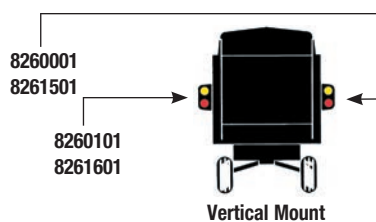
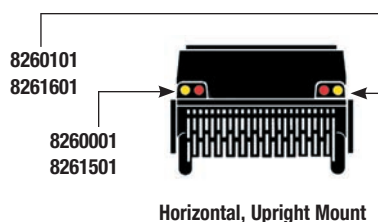

7-WAY AG ROUND PIN WIRING DIAGRAM

**7-WAY MOLDED TRAILER/
SEALED CAR CONNECTOR & CABLE**

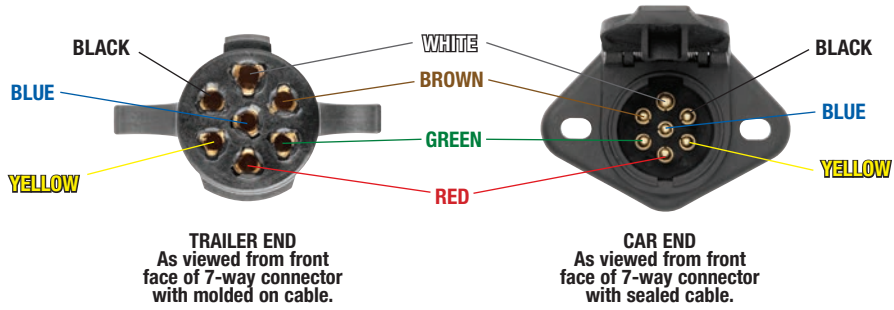

7 - W A Y W I R I N G I N D E X

Wire Color	Molded Trailer/Sealed Car Connector Terminal	Thermo-Plastic/Metal Connector Terminal
White	Common Ground	Common Ground
Black	Work Lamps	Work Lamps
Yellow	Left-Hand Flashing & Turn Indicators	Left-Hand Flashing & Turn Indicators
Red	Stop Lamps	Stop Lamps
Green	Right-Hand Flashing & Turn Indicators	Right-Hand Flashing & Turn Indicators
Brown	Tail Lamps	Tail Lamps
Blue	Switched Power (12 volt)	Switched Power (12 volt)

BREAKAWAY SWITCH INSTALLATION INSTRUCTIONS

READ THIS FIRST:

Read and follow all instructions carefully before installing or operating the breakaway Switch. Keep these instructions for future reference.

Important Facts to Remember

1. **ATTENTION INSTALLER:** Please give this sheet to consumer upon completion of installation.
2. **SAFETY ITEM:** Solder all wire connections.
3. Check condition of battery prior to each trip.
4. **⚠ WARNING** Disconnect trailer plug before testing breakaway unit. Failure to do so will result in severe damage to electronic brake control.
5. **⚠ WARNING** Check your breakaway system periodically to insure that wiring and connections are secure. A short or an open circuit can result in a no-brake condition.
6. For optimal performance, it is recommended that breakaway devices be replaced every 3-5 years.

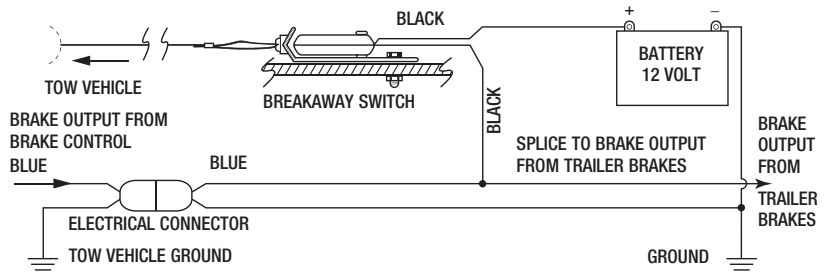

Installation Guide

1. Mount Battery Case securely to frame, jack post or other suitable location on trailer with Breakaway Switch Cable towards tow vehicle.
2. **⚠ WARNING** Switch location should be selected to ensure unobstructed line of pull in event of vehicle separation.
3. Bolt breakaway switch bracket to frame of trailer or battery case bracket using 1/4" bolt and lock nut or (2) 1/4" jam nuts. (Bolt and nuts not included in kit.)
4. **⚠ WARNING** Do not over tighten bolt. Switch must be able to pivot.
5. Disconnect trailer from tow vehicle. Check and install battery.
6. Wire per schematic. Properly insulate all connections.
7. Attaching to tow vehicle: Attach Breakaway Switch Cable to tow vehicle frame being certain the cable does not drag on the ground and no strain or restriction is placed on the cable.
8. **⚠ WARNING** Do not hook cable to safety chain loop or hitch ball.

ABCD/TOW CHARGER/12 VOLT LEAD-ACID BATTERY INSTRUCTIONS AND INSTALLATION

READ THIS FIRST:
Check condition of battery prior to installation and prior to each trip.

1. Remove Charger and Battery from the battery case.
2. Mount battery case securely to frame, jack post or other suitable location on trailer.
3. Bolt Breakaway Switch\ to frame of trailer or battery case bracket.
4. Disconnect trailer from tow vehicle. Install battery and charger into the battery case. Feed wires out the back, then close the top.
5. Wire per schematic diagram. Properly insulate all connections.

6. Provide adequate air circulation when charging battery. Do not charge battery in any other container besides the supplied battery box.
7. **CAUTION** Do not place batteries in close proximity to objects which can produce sparks or flames.
8. Do not expose battery case to organic solvents or adhesives.
9. **CAUTION** Do not attempt to disassemble batteries. Contact with sulfuric acid may cause harm.
10. **CAUTION** Fasten batteries tightly and make provisions for shock absorption if exposure to shock or vibration is likely.
11. **WARNING** Do not throw batteries into fire; batteries so disposed may rupture or explode.

Battery Data Chart

- 12 VOLT
- Maximum charge current must be limited to 1.2 amps
- Length = 3.54" Width = 2.76" Height = 4.13" Terminals: Fasten Tab .187" x .032"
- Service Life:
Under normal operating conditions, 4-5 years in standby applications or 200-1000 charge/discharge cycles depending upon depth of discharge and rate of charge.

Important Facts to Remember

1. **CAUTION** Improper installation of the breakaway battery will destroy the brake control. The negative (-) terminal must attach to ground and positive (+) terminal must attach to the breakaway switch.
2. **WARNING** Check your Breakaway System\ periodically to insure that wiring and connections are secure. A short or an open circuit can result in a no-brake condition.
3. If excessive discharging of the breakaway battery occurs, check battery and recharge using a Heavy Duty Multi Stage/Maintenance Charger. Tekonsha charger 2024-07 is recommended for proper charging.
4. If the secondary battery needs charging, current will be drawn from the tow vehicle's battery at anytime the tow vehicle is connected to the trailer. Tekonsha charger 2024-07 is recommended for proper charging.
5. To only charge the breakaway battery when vehicle is running, a battery isolator may be installed in the 12 volt supply line (RED wire for tow charger).

HEAVY DUTY QUICK/MAINTENANCE MULTI STAGE CHARGER

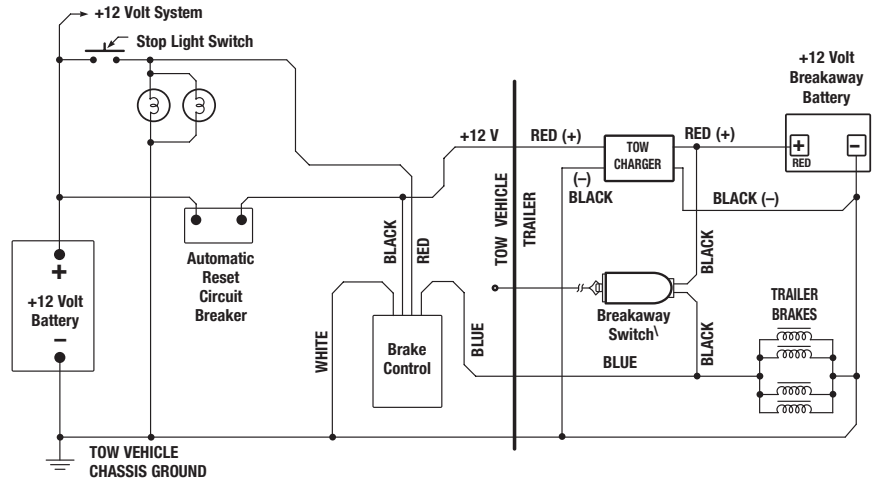

ABCD (Accelerated Battery Charging Device)

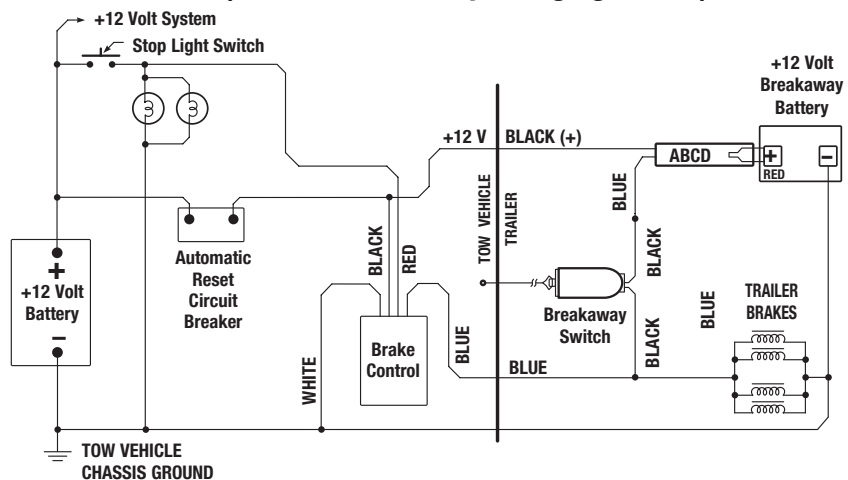

12 Volt Sealed Lead-Acid Battery

To maximize the life of the battery the following conditions should be met:

1. Avoid over or undercharge. This is the single worst enemy of lead-acid batteries.
2. Batteries should not be stored in a discharged state or at elevated ambient temperatures.
3. Avoid exposing batteries to heat! Service life is shortened considerably at ambient above 30°C (86°F).
4. Due to the characteristics of this battery, after six to nine months of storage, the battery should be recharged.
5. Charge the battery at the proper rate. Current should be limited to 1.2 amps or less.

* Refer to Breakaway Switch Installation Instructions for complete operating instructions and cautionary statements.

TRAILER BRAKE TROUBLESHOOTING

NO BRAKES

- Check for defective circuit breaker.
- Check for open or shorted circuit.
- Check for properly wired system, including a good ground between towing vehicle and trailer, not through trailer hitch.
- Check for defective controller or loose wiring at controller.
- Check brake adjustment.
- Check for defective resistor or loose wiring at resistor (hydraulic units only).
- Check for defective or worn magnet(s).
- Check for damaged or worn connector between towing vehicle and trailer.
- Ensure correct controller is installed.

INTERMITTENT OR SURGING BRAKES

- Check for defective circuit breaker.
- Check for out-of-round brake drums.
- Check for properly wired system, including a good ground between towing vehicle and trailer, not through trailer hitch.
- Check for defective magnets or magnet wiring.
- Check for loose or worn wheel bearings.

INEFFECTIVE OR WEAK BRAKES

- Insure trailer is not overloaded.
- Check for loose or corroded connections.
- Check for properly wired system, including a good ground between towing vehicle and trailer, not through trailer hitch.
- Check for shorted circuit.
- Check for proper variable resistor resistance (external resistor or controller) to trailer (for hydraulic units only).
- Worn or defective magnet.
- Check brake adjustment. Check for bent backing plate flange.
- Check for contaminated brake linings.
- Check brake system wiring to ensure proper gauge wiring is used. Ensure wiring is not connected through the stop light circuit.
- Check for worn, damaged or improper brake linings.
- Check for weak or broken brake shoe return spring.
- Check for defective or worn brake drums.
- Check for loose axle.
- Check that correct controller is installed.
- Improper controller installed or settings (level or gain).

GRABBING OR LOCKING BRAKES

- Check for improperly installed flanges.
- Check for contaminated brake linings (grease on linings).
- Check for weak or broken brake shoe return spring.
- Check for out-of-round brake drums.
- Ensure a variable resistor is installed (if necessary) (hydraulic units only).
- Check for variable resistor for proper resistance (hydraulic units only).

GRABBING OR LOCKING BRAKES (Continued)

- Check that correct controller is installed.
- Rust on armature plate or brake drum.
- Check for loose or worn wheel bearings.
- Improper controller installed position.
- Check for improper gain setting.
- Check for improper boost setting.

DRAGGING BRAKES

- Check brake adjustment.
- Check for defective controller.
- Check for improperly installed flange.
- Check for corroded brake assembly.
- Check for weak or broken brake shoe return spring.
- Check for worn or damaged lever arm between magnet and brake shoe.
- Improper controller installed position.

NOISY BRAKES

- Check brake adjustment.
- Check for worn brake shoes.
- Check for contaminated brake linings.
- Check for weak or broken shoe return springs.
- Check for bent backing plate.
- Check for improperly installed flange.
- Check wheel bearing adjustment.
- Check for worn or damaged wheel bearings.
- Check for worn or damaged magnets.

BRAKES LOCKED, BRAKE PEDAL NOT DEPRESSED

- Check stoplight switch adjustment.
- Check for short between stoplight switch circuit and power supply circuit.
- If brakes are locked when 4-way flashers are operated, check for Pulse Preventer installed in circuit.
- Check breakaway switch (pulled).

UNEVEN TIRE WEAR

Possibly due to: A bent or misaligned axle, improper tire inflation. On tandem axle trailers, check voltage at front axle and rear axle with brakes applied. At times, the front axle will "lift" allowing front wheel to lock and slide. Correction can be made installing magnets with even resistance.

INOPERATIVE BREAKAWAY SWITCH

- Check for dead or weak 12-volt battery, on trailer.
- Check all wiring and connections.
- Check breakaway switch.
- If only one brake is operating, check other magnets.

TRAILER BRAKE ADJUSTMENT**

Brakes should be adjusted after the first 200 miles of operation when the brake shoes and drums have "seated" and at 3000 mile intervals, or as use and performance requires. The brakes should be adjusted in the following manner:

1. Jack up trailer and secure on adequate capacity jack stands. Follow trailer manufacturers recommendations for lifting and supporting the unit. Check that the wheel and drum rotate freely.

⚠ WARNING Do not lift or support trailer on any part of the axle or the suspension system.

2. Remove the adjusting hole cover from the adjusting slot on the bottom of the brake backing plate.
3. With a screwdriver or standard adjusting tool, rotate the starwheel of the adjuster assembly to expand the brake shoes. Adjust the brake shoes out until the pressure of the linings against the drum makes the wheel very difficult to turn.

Note: With drop spindle axles, a modified adjusting tool with about an 80 degree angle should be used.

4. Then rotate the starwheel in the opposite direction until the wheel turns freely with a slight lining drag.

5. Replace the adjusting hole cover and lower the wheel to the ground.

6. Repeat the above procedure on all brakes.

⚠ WARNING Never crawl under your trailer unless it is resting on properly placed jack stands.

Follow the trailer manufacturers recommendations for lifting and supporting the unit. Do not lift or place supports on any part of the suspension system.

**Note: Trailer Brake Adjustment procedures courtesy Dexter Axle.

ELECTRIC TRAILER BRAKE PART IDENTIFICATION

Manufacturer Identification

AL-KO	AL-KO levers are very flat. The brake shoes do not have anything unusual about them. AL-KO uses only one return spring at the top on both 10 and 12-inch units. With the drum off, you can tell what size the system is if the magnets have never been replaced. The 10-inch brake will have a magnet with light green wires and the 12-inch brake will have white wires.
Dexter	Dexter uses a stamp on the back of the backing plate that identifies the size of the brake. Looking on the back side you will see a triangle. Around the triangle you will see Dexter and the size (i.e. 10" X 2 1/2" or 12" X 2"). Dexter uses 2 return springs on all late model brakes; some early 12-inch brakes used a single return spring.
Hayes	Hayes brake shoe webs have a tooth that hangs down at the top and use a single return spring. Early 12-inch brakes used a dual return spring. Hayes axle is owned by AL-KO. AL-KO backing plates have been seen on some of the new Hayes axles. It looks as if they are still using the Hayes name and are starting to use AL-KO parts.
Fayette	Fayette axles are obsolete. If you find a Fayette axle tag and the trailer is worth keeping you should consider changing the axles to AL-KO or Dexter. At that time it is recommended that the spring hangers and bushings also be replaced.

Brake Size Identification

Axle Identification	Axles generally have an ID tag located on the axle crossbar that gives you the axle capacity. Check there first. This would give you a starting reference point.
Brake Drum / Shoe Size	Measuring is the same for all brands. Using a tape measure you can do a random measurement as to the diameter by measuring across the drum. If it is a 10-inch drum you will measure approximately 11 inches across for an outside measurement. The 12-inch brake will measure approximately 13 inches for an outside measurement. The drum would need to be removed to get the correct diameter and width.

Magnet Identification

Magnets can be identified by the color of the wire used

Dexter 7" X 1 1/4"	The magnets are round. Prior to April 1990 they had yellow wires, after 1990 the magnet has white wires. Replacement of magnets will need to be done in pairs and updated to the new magnet along with the lever. The early levers are weak and will bend and hang up as they wear.
Dexter 10" X 1 1/2"	The magnet wires for the early model round magnets are white and the late model oval magnets are yellow.
Hayes 10" X 1 5/8"	The magnet wires for the early model round magnets are red and the late model oval magnets are green.
AL-KO 10" X 2 1/4"	It will have light green wires.
Hayes 10" X 2 1/4"	The early model round will have red wires and the late model will have oval green wires.
Dexter 10" X 2 1/4"	It uses green wires.
Fayette 10" X 2 1/4"	The round magnets will have white wires (obsolete).
AL-KO 12" X 2"	It will have white wires.
Hayes 12" X 2"	The early model round magnet will have red wires, the late model will be an oval magnet with white wires.
Dexter 12" X 2"	It will have white wires.
Dexter Centerline 12" X 2"	The 4.5K axles will have red orange wires, the 6/7K axles will have red wires (obsolete for both sizes).

TECHNICAL INFORMATION IS CURRENT AS OF THE PRINTING OF THIS CATALOG. CONTACT TECHNICAL SERVICE FOR PERIODIC UPDATES.

INSTRUCTIONS FOR THE BENCH TESTER

Many apparent brake control “failures” are the result of either faulty wiring or improper setup. The Tekonsha® Bench Tester is a test device designed to assist in determining if a brake control is working properly. This unit allows you to check a brake control for output, independent of vehicle wiring. The Bench Tester can simulate many fault conditions including open ground, short circuit, open load, and more.

To Use Bench Tester:

1. Turn off the power of the Bench Tester.
2. Disconnect the brake control from the tow vehicle.
3. Strip the insulation from the brake control’s wires to about 1/4 inch and clip the matching color/function alligator clip of its corresponding stripped wire. **DO NOT REVERSE THE GROUND AND POWER WIRES AS YOU MAY PERMANENTLY DAMAGE THE BRAKE CONTROL**
4. Turn on the power of the Bench Tester.

If the control being tested is manufactured by Tekonsha:

1. The brake control’s LED should glow green if it has a bi-colored LED. The display should show a “.c” if it has a digital readout. If you have the P3 brake control, you will see the Tekonsha logo. These conditions indicate a normal load connection.
2. Now set the brake control’s power setting to maximum and actuate the control’s manual override lever. The output voltage on the Bench Tester’s voltmeter should read about 12 volts and the brake control LED display should glow bright red or show either 12 or 13. Release the manual lever. Lay the control on a flat surface and follow the directions for leveling the sensor per manufacturer’s instructions.
3. Depress and hold the Bench Tester’s brake switch.
 - A. If you are testing a proportional control, tilt the brake control by moving the front of the control up to about 30-45 degrees to fully activate the accelerometer. The voltage on the tester’s meter should again read approximately 12V.

- B. If the control being tested is a time-actuated device, you will see the voltage progressively “ramp-up” to the control’s maximum output.

NOTE: If the brake control works normally on the Bench Tester then the problem is likely in the vehicle wiring or the control setup. If you check the vehicle/trailer wiring and it appears to be normal you can refer to our product catalog or visit our web site for control setup and / or additional troubleshooting assistance.

CAUTION Tekonsha controls are built to withstand many electrical fault conditions without damage to their ultimate performance. Please be aware that some competitive products may not be capable of surviving the same punishment so care should be exercised when testing these units.

INSTRUCTIONS FOR THE CURRENT MONITOR

The Current Monitor is a testing device designed to assist in determining whether a tow vehicle’s trailer connector has been wired properly. This unit is also an excellent diagnostic tool for the installation, setup and troubleshooting of electric trailer brake controls and may be used to level and pre-set a brake control when a trailer is not available.

To Use Current Monitor:

1. Simply plug the tester into the vehicle’s trailer connector.
2. Sitting in the driver’s seat, position the switch (located between the amp meter & voltmeter gauges) to the “Trailer Brakes” position.
3. Then position the switch labeled “Number of Axles” to the appropriate position for the trailer that is expected to be towed.
4. Now, activate each function indicated by the four LED lights across the front of the test unit. Once it has been determined that all lighting connections are working properly, test the output of the vehicle’s trailer brake control.

NOTE: Be sure the brake control has been properly leveled per manufacturer’s instructions.

5. Depress the vehicle’s brake pedal and/or engage the brake control’s manual override.
 Brake Voltage must register at least 10 Volts. Brake Control Current Output should register at least:
 12 Amps for two (2) axle trailers, or 18 Amps for three (3) axle trailers.

NOTE: If the brake control will not generate 18 or more amps when used with three or more axle trailers BE SURE that you are using a brake control designed to deliver this performance.

If you discover a performance or wiring problem, look for one or more of the following fault conditions:

1. Improper wiring of the brake control to the vehicle’s power and/or battery ground. (As with any electronic device, Cequent™ Electrical Products recommends grounding all brake controls directly to the vehicle battery to ensure the proper performance of the control’s advanced circuitry.)
2. Defective or improper wiring of the trailer connector.
3. Broken, dirty or corroded trailer connector pins.
4. Open brake magnets, or open,

broken or shorted wiring.

5. Defective brake control.

WARNING This unit contains magnets, which may become hot if the unit is left connected to an energized brake control for more than a few minutes.

SB0029 REV 5.0

TECHNICAL INFORMATION IS CURRENT AS OF THE PRINTING OF THIS CATALOG. CONTACT TECHNICAL SERVICE FOR PERIODIC UPDATES.

INSTRUCTIONS FOR TRAILER TESTER

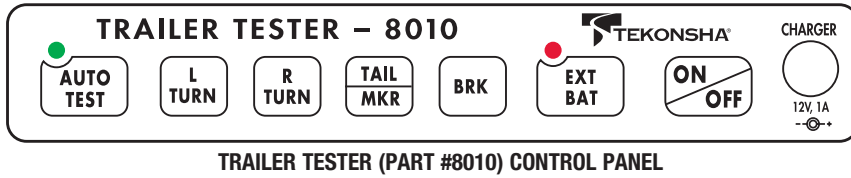

TRAILER TESTER (PART #8010) CONTROL PANEL

The Trailer Tester (Part #8010) is designed to help you quickly identify problems in the wiring of the trailer such as opens, shorts, incorrect wiring, etc. This is done by testing the Left Turn, Right Turn, Tail/Marker, Brake and Back Up circuits on the trailer, by indicating the approximate amount of current used in each circuit. It will also test the voltage of the external battery connected to the trailer charge circuit (i.e. trailer battery).

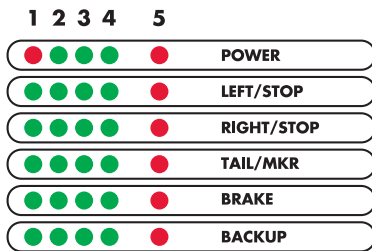

NOTE: The above LED light reference numbers are used in the following instructions for all rows.

READ THIS FIRST:

Read and follow all trailer warnings and installation instructions before continuing.

- Check to see that the mating surfaces of the trailer wiring connector matches the Trailer Tester connector. All connector surfaces should be clean and free of dirt. For proper operation, make sure the trailer tester battery is fully charged. Plug the trailer connector firmly into the Trailer Tester. Be sure that the connector is fully inserted.
- Turn the tester ON by pressing the ON button. All LEDs will cycle in order from top to bottom and left to right and will flash once. The tester is ready for use.
- INDICATOR "LED" LIGHTS – POWER ROW ONLY (Measuring the internal battery of the tester – LED will remain lit after power has been turned on)
 - Green LEDs 2, 3 and 4 mean that the internal battery is OK to perform tests.
 - Red LED 1 flashing means that the internal battery needs to be charged (see "Charging the Internal Battery" instructions below) or may need to be replaced.
 - Red LED 5 indicates that the battery is faulty or overcharged. Battery may need to be replaced.

4. CHARGING THE INTERNAL BATTERY

CAUTION

ONLY USE THE CHARGER (part no. 8008) PROVIDED WITH THE 8010 TESTER

- When the charger is plugged into the charger socket, Red LED 5 on the Power Row flashes if the unit is ON.
- If the unit is OFF, no LEDs will be lit, but the battery will still charge.
- The LED on the charger is RED while charging.
- The LED on the charger will turn GREEN when the battery is fully charged.

NOTE: The trailer tester will not function while the internal battery is being charged.

5. MANUAL AND AUTO TEST – LEFT/STOP, RIGHT/STOP, TAIL, BRAKE, BACKUP CHANNELS

AUTO TESTING (measuring the amount of load on each channel):

- Press the AUTO TEST button. When pressed, its indicator Green LED begins to flash.
- Each channel will be tested from top to bottom
- Red LED 5 will flash as its channel is tested
- Green LED(s) will remain ON to indicate the amount of load. (See Step 6 for LED display load readouts)
- See Step 7 for LED fault indication readouts.
- MANUAL TESTING (visual test of trailer lighting)
 - Depressing any manual button will cause that same channel to flash 11 times. This will allow you to walk around the trailer and confirm that lights are functioning properly.
 - The Trailer Tester will automatically shut down after three minutes to conserve the battery.
 - See Step 7 for LED fault indication readouts.

NOTE: To CLEAR THE DISPLAY or TURN OFF AUTO TEST, simply press the auto test button. Then you are ready to test again.

6. HOW TO READ THE LED DISPLAY (for approximate load readouts)

LEFT/STOP, RIGHT/STOP and BACKUP Load Readouts:

- Green LED 1 represents .25 amps
- Green LED 2 represents 2 amps
- Green LED 3 represents 3 amps
- Green LED 4 represents 4 amps

TAIL Load Readout:

- Green LED 1 represents .25 amps
- Green LED 2 represents 4 amps
- Green LED 3 represents 6 amps
- Green LED 4 represents 8 amps

BRAKE Load Readout:

- Green LED 1 represents 1 axle
- Green LED 2 represents 2 axles
- Green LED 3 represents 3 axles
- Green LED 4 represents 4 axles

NOTE: All current measurements are standard to RV.

7. FAULT INDICATION (See graph below)

- Red LED(s) 5 flashing on the affected channel represents: INTERCHANNEL SHORT OR REVERSED WIRES
- Red LED 5 solid on the affected channel represents: NO LOAD/OPEN CIRCUIT
- Green LEDs 1-4 and Red LED 5 all solid on the affected channel represents: OVERLOAD
- Green LEDs 1-4 and Red LED 5 flashing on the affected channel represents: SHORT CIRCUIT TO GROUND

8. EXTERNAL BATTERY (Measures the trailer battery's (if present) open circuit voltage)

- Press the EXT BAT button. When pressed, its indicator Red LED will light.
- Voltage will be displayed by lit LEDs in the Power Row only.
- Green LED's 2 and 3 mean that the external battery has normal voltage.
- Red LED 1 flashing means that the external battery needs to be charged or may need replacement.
- Red LED 5 indicates that the battery is faulty or overcharged. Battery may need replacement.

NOTE: This test will automatically stop after a few seconds and the red light will go out.

NOTE: This test does not indicate the amount of charge left in the trailer battery. (Excludes breakaway battery)

FAULT INDICATION GRAPH

DISPLAY	HOW TO READ THE FAULT ON AN AFFECTED CHANNEL
● ● ● ● ●	INTER-CHANNEL SHORT BETWEEN THE FLASHING CHANNELS OR REVERSED WIRES
● ● ● ● ●	NO LOAD OPEN CIRCUIT
● ● ● ● ●	OVERLOAD
● ● ● ● ●	SHORT CIRCUIT TO GROUND
● ● ● ● ●	LOW BATTERY, CHARGE OR REPLACE (POWER ROW ONLY)

LEGEND	
●	CONSTANT ON
⚡	RED LED FLASHING
○	RED LED OFF
●	GREEN LED ON
⚡	GREEN LED FLASHING
○	GREEN LED IS OFF



HORIZON GLOBAL **THE HIGHEST QUALITY OF** **CUSTOM ENGINEERING**

INDEMNIFICATION / WARRANTIES / NUMERICAL

INDEMNIFICATION PROGRAM

Installation Indemnification Program.....2

WARRANTIES

Limited Lifetime Warranty.....3

Limited Year Warranty.....3

APPLICATION PRODUCT NUMERICAL

Class I Receiver Hitches.....4-6

Class II Receiver Hitches.....6-9

Class III/IV Receiver Hitches.....9-16

Class III/IV Multi-Fit Receiver Hitches.....16-17

Class V Receiver Hitches.....17-19

Class V (2-1/2") Receiver Hitches.....19

Front Mount Receiver Hitches.....19-21

1-Plug Adapters.....21-22

2-Plug Adapters.....22-24

T-One Connectors.....24-30

Tow Harnesses.....30-31

Fifth Wheel Harnesses.....31-34

6 / 7-Way Connectors.....34-35

Fifth Wheel Rail Kits.....35-37

Elite™ Series Fifth Wheel Rail Kits.....37

Elite™ Series Gooseneck.....37

Under-Bed Gooseneck.....37-38

Above-Bed Gooseneck.....38

Roofs Racks.....38-43

Truck Bed Racks.....43

PRODUCT NUMERICAL

Product Numerical.....44-64



How would you like to reduce the cost of your hitch installation liability insurance and get **ADDITIONAL PROTECTION FREE?**



INSTALLED

Install Cequent Performance Products, Inc branded applicable products properly, according to the instructions included.



INFORMED

Before installation begins, present the towing safety form to the customer and have them read and sign it.

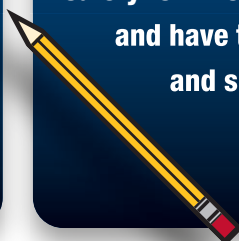

INSURED

A: Give the copy of the signed towing safety form to the customer.
B: Retain the original signed towing safety form for your records.

DEALER SUPPORT

In the interest of safe towing, Draw-Tite®, Hidden Hitch®, and Reese® offer this Dealer Installation Indemnification Program. We're committed to designing and building the industry's highest quality trailer hitches and towing accessories. We also back our equipment with an extraordinary level of support for our customers. Once enrolled in the Dealer Installation Indemnification Program, when you sell and properly install complete Draw-Tite®, Hidden Hitch®, or Reese® applicable products according to written instructions and provide your customers with the required information for safe and proper towing, you are indemnified on any claim over USD \$2,000 arising from your installation of Horizon branded products. *(For conditions and limitation see Dealer Agreement.)*

INDEPENDENT OF THIS AGREEMENT, THE HORIZON GLOBAL, INC LIMITED LIFETIME WARRANTY REMAINS IN EFFECT WITH RESPECT TO PRODUCT CLAIMS.

To enroll in the program, contact your Sales Representative

DEALER BENEFITS

What you receive is the potential of significant cost savings by reducing your installation liability coverage for Horizon branded products. We design and build safety into everything we produce, so we have the confidence to back Horizon branded products with this comprehensive program. Therefore you'll be able to serve your customers with a new level of confidence, knowing Horizon backs your work. However, Horizon recommends you determine your base liability coverage requirements with your local insurance professional.

ELIGIBILITY

To qualify for the Dealer Installation Indemnification Program, you must be a qualified Draw-Tite® or Reese® Installer. If you install other manufacturers' products, you will need to maintain liability insurance to cover non Horizon branded products.

PROGRAM COST

There is no charge to the participating Dealer.



LIMITED LIFETIME WARRANTY

- 1. Limited Lifetime Warranty (“Warranty”). Horizon Global, Inc. (“We” or “Us”) warrants to the original consumer purchaser only (“You”) that the product will be free from material defects in both material and workmanship, ordinary wear and tear excepted; provided that installation and use of the product is in accordance with product instructions. There are no other warranties, express or implied, including the warranty of merchantability or fitness for a particular purpose. This warranty is not transferable.
- 2. Limitations on the Warranty. This Warranty does not cover: (a) normal wear and tear; (b) damage through abuse, neglect, misuse, or as a result of any accident or in any other manner; (c) damage from misapplication, overloading, or improper installation; (d) improper maintenance and repair; and (e) product alteration in any manner by anyone other than Us, with the sole exception of alterations made pursuant to product instructions and in a workmanlike manner.
- 3. Obligations of Purchaser. To make a Warranty claim, contact Us, identify the product by model number, and follow the claim instructions that will be provided. Any returned product that is replaced by Us becomes our property. You will be responsible for return shipping costs. Please retain your purchase receipt to verify date of purchase and that You are the original consumer purchaser. The product and the purchase receipt must be provided to Us in order to process Your Warranty claim.
- 4. Remedy Limits. Product replacement is Your sole remedy under this Warranty. We shall not be liable for service or labor charges incurred in removing or replacing a product or any incidental or consequential damages of any kind.
- 5. Assumption of Risk. You acknowledge and agree that any use of the product for any purpose other than the specified use(s) stated in the product instructions is at Your own risk.
- 6. Governing Law. This Warranty gives You specific legal rights, and You also may have other rights which vary from state to state. This Warranty is governed by the laws of the State of Michigan, without regard to rules pertaining to conflicts of law. The state courts located in Oakland County, Michigan shall have exclusive jurisdiction for any disputes relating to this Warranty.

LIMITED 1/3/5/7/10/15 YEAR WARRANTY

- 1. Limited Warranty. Horizon Global, Inc. (“We” or “Us”) warrants to the original consumer purchaser only (“You”) that the product will be free from material defects in both material and workmanship for a specific period*, ordinary wear and tear excepted; provided that installation and use of the product is in accordance with product instructions. There are no other warranties, express or implied, including the warranty of merchantability or fitness for a particular purpose. If the product does not comply with this period specific limited warranty*, Your sole and exclusive remedy is that We will replace the product without charge to You and within a reasonable time or, at our option, refund the purchase price. This warranty is not transferable.
- 2. Limitations on the Warranty. This limited warranty does not cover: (a) normal wear and tear; (b) damage through abuse, neglect, misuse, or as a result of any accident or in any other manner; (c) damage from misapplication, overloading, or improper installation, including welds; (d) improper maintenance and repair; and (e) product alteration in any manner by anyone other than Us, with the sole exception of alterations made pursuant to product instructions and in a workmanlike manner.
- 3. Obligations of Purchaser. To make a warranty claim, contact Us, identify the product by model number, and follow the claim instructions that will be provided. Any returned product that is replaced or refunded by Us becomes our property. You will be responsible for return shipping costs. Please retain your purchase receipt to verify date of purchase and that You are the original consumer purchaser. The product and the purchase receipt must be provided to Us in order to process Your warranty claim.
- 4. Remedy Limits. Repair or replacement is Your sole remedy under this limited warranty or any other warranty related to the product. We shall not be liable for service or labor charges incurred in removing or replacing a product or any incidental or consequential damages of any kind.
- 5. Assumption of Risk. You acknowledge and agree that any use of the product for any purpose other than the specified use(s) stated in the product instructions is at Your own risk.
- 6. Governing Law. This limited warranty gives You specific legal rights, and You also may have other rights which vary from state to state. This limited warranty is governed by the laws of the State of Michigan, without regard to rules pertaining to conflicts of law. The state courts located in Oakland County, Michigan shall have exclusive jurisdiction for any disputes relating to this warranty.

RECEIVER HITCH APPLICATION NUMERICAL

PC	PART NO.	YEARS	MAKE/MODEL	WGT LBS	IN
CLASS 1: 1-1/4" HITCH					
36	24526	92-09 79-82 83-86 83-91 83-91 80-83 81-02 87-91 83-11 83-86 03-04 79-82 79-82	Ford Crown Victoria Ford LTD Ford LTD Country Squire Wagon Ford LTD Crown Victoria Ford LTD Crown Victoria Wagon Lincoln Mark VI Lincoln Town Car Mercury Colony Park Wagon Mercury Grand Marquis Mercury Grand Marquis Colony Park Wagon Mercury Marauder Mercury Marquis Sedan Mercury Marquis Wagon	31	25 25 25 25 25 25 25 25 25 25 25 25
17	24534f	90-91 87-91 87-91	Lexus ES250 FWD Toyota Camry 4 Dr. Sedan Toyota Camry Wagon	10	40 40 40
36	24557	87-95 87-95	Jeep Wrangler Jeep YJ (Canada Only)	21	30 30
36	24563	92-01 92-96	Lexus ES300 4 Dr. Toyota Camry	27	30 30
25	24579	98-02 93-97 93-02	Chevrolet Prizm GEO Prizm Toyota Corolla Sedan	20	30 30 30
45	24586f	93-02	Chevrolet Camaro Except w/Dual Exhaust Pipes On Drivers Side	31	40
22	24589	94-01	Acura Integra	17	40
35	24594	94-98	Volkswagen Jetta Jetta III	30	30
31	24606	91-98	Toyota Tercel Sedan	19	30
39	24613	03-05 95-02 03-05 00-02 95-99	Chevrolet Cavalier LS Sport Chevrolet Cavalier Z-24 Chevrolet Cavalier Z-24 (Canada Only) Pontiac Sunfire Pontiac Sunfire GT	29	40 40 40 40 40
45	24616	94-97	Honda Accord	29	30
33	24620	91-92 93-02 93-02 91-02 91-02 91-02 93-99 93-01	Saturn SC 2 Dr. Coupe Saturn SC1 2 Dr. Coupe Saturn SC2 2 Dr. Coupe Saturn SL 4 Dr. Sedan Saturn SL1 4 Dr. Sedan Saturn SL2 4 Dr. Sedan Saturn SW1 Wagon Saturn SW2 Wagon	25	40 40 40 40 40 40 40 40
25	24622	98 89-97 89-95 96-98 96-98	Chevrolet Tracker GEO Tracker Suzuki Sidekick Suzuki Sidekick Except Sport Model Suzuki X-90	18	20 20 20 20 20
23	24628	95-00 95-99	Chevrolet Lumina Chevrolet Monte Carlo	20	30 30
27	24631	97-06 97-06	Jeep TJ (Canada Only) Jeep Wrangler	19	15 15
45	24639	90-93	Honda Accord	26	20
27	24646	96-00	Hyundai Elantra	13	30
34	24656	97-05 97-99	Chevrolet Malibu 4 Dr. Oldsmobile Cutlass 4 Dr., FWD	22	15 15
24	24659	97-05 98-02 97-03	Buick Century Sedan Oldsmobile Intrigue Pontiac Grand Prix SE Sedan	13	30 30 30
27	24660	97-04 97-08	Buick Regal (App. starts with 97-1/2) Pontiac Grand Prix	13	20 20
29	24673	99-04 99-05 99-04 02-06	Chevrolet Tracker Suzuki Grand Vitara Suzuki Vitara Suzuki XL-7	18	15 15 15 15
25	24675	99-03	Mazda Protege	26	20
29	24677	97-01 92-00	Acura EL (Canada Only) Honda Civic	19	15 15
39	24679	98-01 02-10 99-06 07-10	Volkswagen Beetle Volkswagen Beetle Except Turbo S Volkswagen Golf Volkswagen Golf City (Canada Only)	31	30 30 30 30
25	24681	00-05	Chevrolet Impala	16	20
33	24682	03-07 00-03	Ford Focus Wagon (Built After 11/2002) Ford Focus Wagon (Built Before 11/2002)	27	20 20
14	24685	01-02 01-02 01-02	Saturn I100 Saturn L200 Saturn L300	14	35 35 35

PC	PART NO.	YEARS	MAKE/MODEL	WGT LBS	IN
14	24685	00 00 00 03 03	Saturn LS Saturn LS1 Saturn LS2 Saturn LW200 Wagon Saturn LW300 Wagon	14	35 35 35 35 35
34	24686	96-01 02-04 95-03	Infiniti I30 Infiniti I35 Nissan Maxima Sedan	18	30 30 30
29	24687	94-98 99-04	Ford Mustang Ford Mustang Except Cobra SVT	27	20 20
39	24690	93-01	Nissan Altima	22	20
24	24692	00-04 05-07 00-06	Ford Focus Sedan Ford Focus Sedan, Except w/Street Appearance Pkg. Ford Focus ZX3 3 Dr. Hatchback, Except SVT & w/Street Appearance Pkg.	15	20 20 20
20	24698	99-05 99-05	Volkswagen Passat 4 Dr. Sedan, Except 4 Motion & W8 Engine Volkswagen Passat Wagon, Except 4 Motion & W8 Engine	19	40 40
35	24699	86-03 96-99 86-03 88-02 86-03 86-03	Ford Taurus 4 Dr. Sedan Ford Taurus 4 Dr. Sedan, Except SHO Ford Taurus Wagon Lincoln Continental Mercury Sable Sedan Mercury Sable Wagon	29	20 20 20 20 20 20
42	24701	00-05 00-01	Dodge Neon Plymouth Neon	30	20 20
25	24702	96-03 04-07 01-03 96-03 04-07 96-03 04-07 96-00 96-00	Chrysler Town & Country Chrysler Town & Country Except w/Stow & Go Seats Chrysler Voyager Dodge Caravan Dodge Caravan Except w/Stow & Go Seats Dodge Grand Caravan Dodge Grand Caravan Except w/Stow & Go Seats Plymouth Grand Voyager Plymouth Voyager	28	30 30 30 30 30 30 30 30 30
33	24703	01-06	Hyundai Elantra	19	15
31	24704	96-05	Toyota RAV4	21	15
31	24706	01-05	Honda Civic	19	15
44	24709	01-04 01-06	KIA Magentis (Canada Only) KIA Optima	18	15 15
25	24710	93-01 02-07	Subaru Impreza Subaru Impreza Except WRX STi	20	30 30
29	24711	01-06	Chrysler Sebring Convertible	20	15
31	24713	02-05	Hyundai Sonata	21	15
36	24714	02-03	Mazda Protege5	28	15
35	24715	97-04 99-03	Toyota Camry 4 Dr. Sedan Toyota Solara	26	15 15
20	24719	02-06 02-05	Acura RSX Honda Civic Si	12	30 30
19	24720	03-04 05-11	Honda Element Honda Element Except SC	10	25 25
27	24721	97-05 97-04 99-05 97-98	Chevrolet Venture Oldsmobile Silhouette Pontiac Montana Pontiac Trans Sport	20	30 30 30 30
25	24726	03-08	Hyundai Tiburon	26	45
33	24727	02-05	KIA Rio	14	20
30	24732	03-06	Mitsubishi Outlander	22	40
31	24733	00-01 03-05 95-02 03-05 95-99	Chevrolet Cavalier Chevrolet Cavalier Except LS Sport Chevrolet Cavalier Except Z-24 Pontiac Sunfire Pontiac Sunfire Except GT	31	40 40 40 40 40
31	24734	03-07	Saturn Ion Except Redline & w/2.4 Liter Engine	38	35
39	24735	03-06	Subaru Baja	27	20
36	24736	00-05	Hyundai Accent	19	20
35	24740	05-06	Nissan X-Trail (Canada Only)	24	45
20	24741	04-11 09 09 05-07 08 04-09	Chevrolet Aveo 5 Dr. Hatchback Pontiac G3 5 Dr. Pontiac G3 Wave 5 Dr. (Canada Only) Pontiac Wave 5 Dr. (Canada Only) Pontiac Wave5 (Canada Only) Suzuki Swift+ 5 Dr. (Canada Only)	13	30 30 30 30 30 30
31	24743	05-09	KIA Spectra Except Spectra5	25	20
20	24745	05-10 05-10	Chevrolet Cobalt 2 Dr., Except SS Chevrolet Cobalt 4 Dr., Except SS	18	40 40

RECEIVER HITCH APPLICATION NUMERICAL

PC	PART NO.	YEARS	MAKE/MODEL	WGT LBS	IN
20	24745	07-09 05-06 05-06	Pontiac G5 Except GT Pontiac Pursuit 2 Dr. (Canada Only) Pontiac Pursuit 4 Dr. (Canada Only)	18	40 40 40
22	24747	05-09	Ford Mustang Except GT/CS (California Special)/Shelby GT/GT500	18	45
29	24748	07-09 99-05	Volkswagen Jetta City Sedan (Canada Only) Volkswagen Jetta Sedan, Except Gas Turbo & Wagon	23	30 30
31	24750	00-06	Nissan Sentra	26	20
24	24754	06-12	Mitsubishi Eclipse	13	30
18	24755	04-08	Acura TL	10	35
30	24756	08 08 05-10 05-10 06-11 08-10 07-09 05-07 04-06	Chevrolet Cobalt Sport 2 Dr. Chevrolet Cobalt Sport 4 Dr. Chevrolet Cobalt SS 2 Dr. Chevrolet Cobalt SS 4 Dr. Chevrolet HHR Chevrolet HHR SS Pontiac G5 GT Saturn Ion 3 w/2.4 Liter Engine Saturn Ion Red Line	40	25 25 25 25 25 35 25 25 25
24	24757	06-10	Hyundai Sonata	21	20
31	24759	01-10 05-09	Chrysler PT Cruiser Chrysler PT Cruiser Convertible	19	30 30
32	24760	06-11 06-11	Hyundai Accent 4 Dr. Sedan KIA Rio 4 Dr. Sedan	20	20 20
27	24763	06-15 06-15 06-15 06-15 06-11 06-11	Honda Civic 2 Dr. Coupe, Except Si Honda Civic 4 Dr. Sedan, Except Hybrid & Si Honda Civic Hybrid Honda Civic Hybrid Honda Civic Si, 2 Dr. Coupe Honda Civic Si, 4 Dr. Sedan	22	30 30 30 35 30 30
24	24764	06-13	Suzuki Grand Vitara	21	20
33	24767	03-07 08-13 04-07 09-13 05-11	Cadillac CTS Cadillac CTS 4 Dr. Sedan Cadillac CTS V Cadillac CTS V 4 Dr. Sedan Cadillac STS	27	45 45 45 45 45
25	24768	06-08	Acura TSX 4 Dr. Sedan	28	40
23	24769	07 08-12	Dodge Caliber Dodge Caliber Except SRT-4	19	15 15
32	24771	06-11	Hyundai Azera	30	20
27	24772	02-06	Honda CR-V	21	20
20	24773	06-10	Mazda 5	17	25
39	24775	06-09 07-09 06 03-08 04-08 06-09	Ford Fusion Lincoln MKZ Lincoln Zephyr Mazda 6 4 Dr. Sedan Mazda 6 5 Dr. Hatchback Mercury Milan	18	45 45 45 45 45 45
18	24776	07-08	Honda Fit	18	25
29	24778	06-10 09-10 06-08	KIA Magentis (Canada Only) KIA Optima KIA Optima (App. starts with 2006-1/2)	19	20 20 20
27	24781	04-11 05-11	Volvo S40 Sedan (App. starts with 2004-1/2) Volvo V50 Wagon, Except T5 R-Design	20	25 25
16	24785	04-07	Mazda 6 Sport Wagon	19	25
31	24787	03-07 03-07	Honda Accord Coupe Honda Accord Sedan	17	25 25
31	24788	02-06 04-08	Nissan Altima Nissan Maxima	26	30 30
18	24790	97-01	Honda CR-V	16	20
18	24791	01-03 99-03 98-02	Acura CL 3.2 Acura TL 3.2 Honda Accord Sedan	18	15 15 15
12	24792	07-11	Honda CR-V	17	20
22	24794	07-12	Nissan Sentra	17	30
28	24795	07-11 07-10 06-11	Hyundai Accent 3 Dr. Hatchback Hyundai Elantra 4 Dr. Sedan KIA Rio5 5 Dr. Hatchback	21	25 25 25
15	24796	07-16 09-17	Nissan Altima Sedan Nissan Maxima	19	45 45
27	24797	07-10 11-12	KIA Rondo KIA Rondo (Canada Only)	18	30 30
35	24798	07-11 07-12	Nissan Versa 4 Dr. Sedan Nissan Versa 5 Dr. Hatchback	25	25 25
28	24801	08-13	Nissan Altima Coupe, Except SR Models	17	30
33	24805	08-11	Ford Focus	23	30
28	24807	09-13	Subaru Forester	29	35

PC	PART NO.	YEARS	MAKE/MODEL	WGT LBS	IN
28	24807	08-11	Subaru Impreza 4 Dr. Sedan	29	35
24	24808	04-09	Toyota Prius	23	30
34	24809	08-09	Saturn Astra Hatchback	24	25
23	24810	06-11	Chevrolet Aveo 4 Dr. Sedan	19	20
28	24811	08-10	Volvo C30	26	45
15	24812	03-08 09-10 03-13 14	Pontiac Vibe Pontiac Vibe Except GT Toyota Matrix Toyota Matrix (Canada Only)	21	15 15 15 15
33	24813	00-05	Toyota Echo Except Hatchback	27	15
22	24814f	03-13	Toyota Corolla	20	20
13	24815	11-13 08-13	Scion tC Scion xB Except Release Series	18	15 15
27	24816	04-09 06-09 04-09 06-09	Mazda 3 4 Dr. Sedan, Except w/Grand Touring LED Taillights Mazda 3 4 Dr. Sedan, w/Grand Touring LED Taillights Mazda 3 5 Dr. Hatchback, Except w/Grand Touring LED Taillights Mazda 3 5 Dr. Hatchback, w/Grand Touring LED Taillights	20	35 35 35 35
18	24817	07-11	Suzuki SX4 Crossover	20	40
11	24819	07-11 07-11 09-11	Toyota Yaris 3 Dr. Liftback Toyota Yaris 4 Dr. Sedan Toyota Yaris 5 Dr. Liftback	14	20 20 20
31	24821	08-09	Pontiac G8	33	45
11	24822	96-00	Honda Civic 3 Dr. Hatchback	7	20
25	24824	07-13	Volkswagen Eos	29	40
19	24825	10-13 10-14 10-13 06-09 07-09 06-09	Volkswagen Golf 2 Dr. Hatchback, Except R Volkswagen Golf 4 Dr. Hatchback, Except R Volkswagen Golf Hatchback (Canada Only), Except R Volkswagen GTI 2 Dr. Hatchback Volkswagen GTI 4 Dr. Hatchback Volkswagen Rabbit	23	15 15 15 15 15 15
21	24826	09-13	Honda Fit	27	25
11	24827	05-10	Scion tC	14	30
14	24828	08-10	Scion xD	19	20
29	24830	09-16	Audi A4 4 Dr. Sedan	25	25
11	24831	07-08 09-13	Infiniti G35 4 Dr. Sedan Infiniti G37 4 Dr. Sedan	16	45 45
25	24832	09-13	Mazda 6 4 Dr. Sedan	30	30
21	24833	06-09 06-09 07-09 07-09 07-09	Pontiac Solstice Pontiac Solstice Pontiac Solstice GXP Pontiac Solstice GXP Saturn Sky	26	35 40 35 40 35
19	24835	07-12	Mitsubishi Galant	16	30
25	24836	05-11 06-10	Audi A6 4 Dr. Sedan Audi A6 Quattro Avant Wagon	16	25 25
13	24839	10-13 10-13	KIA Soul Except w/LED Taillights KIA Soul w/LED Taillights	20	40 40
23	24840f	10	Ford Mustang Except GT/CS (California Special)/Shelby GT/GT500	27	45
25	24842	10-13 10-13	Mazda 3 4 Dr. Sedan, Except w/Grand Touring LED Taillights Mazda 3 4 Dr. Sedan, w/Grand Touring LED Taillights	25	20 20
20	24843	10-13 10-13	Mazda 3 5 Dr. Hatchback, Except w/Grand Touring LED Taillights Mazda 3 5 Dr. Hatchback, w/Grand Touring LED Taillights	17	15 15
14	24844	09-12	Hyundai Elantra Touring, 5 Dr.	21	25
20	24845	09-13	Nissan Cube	27	45
27	24846	10-13	KIA Forte 4 Dr. Sedan	24	20
18	24847	10-15 12-17	Toyota Prius Except w/Plug-In Model Toyota Prius V	18	25 25
22	24848	09-16 06-10 07-10	Volkswagen CC Except 4 Motion Volkswagen Passat 4 Dr. Sedan, Except 4 Motion Volkswagen Passat Wagon, Except 4 Motion	18	35 35 35
31	24850	10-15	Chevrolet Camaro Except Convertible & w/Dealer Installed Ground Effects	21	15
31	24852	10-11 12-15	Honda Accord Crosstour Honda Crosstour	26	40 40
20	24853	11-17 11-15 11-15	Hyundai Sonata Except Hybrid Hyundai Sonata Hybrid KIA Optima	34	30 30 30
27	24854	10-13	Acura ZDX	19	25
25	24855	11-16	Ford Fiesta 5 Dr. Hatchback	26	30
37	24856	11-13	Ford Fiesta 4 Dr. Sedan	21	15
43	24857	07-11 07-08	BMW 328i Sedan BMW 328xi Sedan	29	45 45
23	24860f	10-12	Lexus HS250h Hybrid	20	25
27	24861	06-11	Acura CSX (Canada Only)	21	30

RECEIVER HITCH APPLICATION NUMERICAL

PC	PART NO.	YEARS	MAKE/MODEL	WGT LBS	IN
27	24861	13-17	Acura ILX Except Hybrid	21	35
24	24863	11-14	Ford Mustang V6 Models	19	40
		11-14	Ford Mustang V8 Models		40
25	24865	10-12	Ford Fusion	28	20
		10-12	Lincoln MKZ		20
		10-11	Mercury Milan		20
23	24866	10-14	Volkswagen Golf Wagon (Canada Only)	25	40
		05-14	Volkswagen Jetta 4 Dr. Sedan		40
		09-14	Volkswagen Jetta SportWagon		40
27	24867	11-16	Nissan JUKE AWD, Except Nismo & Nismo RS	23	40
28	24869	11-14	Mazda 2	27	30
52	24870	05-12	Toyota Avalon	32	40
28	24871	11-14	Chrysler 200 4 Dr. Sedan	25	15
		11-14	Chrysler 200 Convertible		15
		07-10	Chrysler Sebring Convertible		15
		07-10	Chrysler Sebring Except Convertible		15
		08-14	Dodge Avenger		15
18	24872	12-14	Ford Focus 5 Dr. Hatchback, Except ST w/Center Exhaust	23	25
		15-16	Ford Focus 5 Dr. Hatchback, Except ST w/Center Exhaust & RS Models		25
		12-16	Ford Focus Sedan		25
28	24873	12-16	FIAT 500 Except Abarth	20	30
24	24874	12-16	Mazda 5	26	25
20	24876	12-15	Chevrolet Sonic 4 Dr. Sedan	20	20
28	24877	12-13	Volkswagen Beetle Except Convertible & Gas Turbo	25	20
25	24878	12-16	Chevrolet Sonic 5 Dr. Hatchback	28	20
29	24879	12-13	Volkswagen Beetle Gas Turbo, Except Convertible	29	30
34	24880	12-17	Volkswagen Passat 4 Dr. Sedan	30	30
27	24881	12-13	Chevrolet Orlando (Canada Only)	35	35
18	24882	12-16	Buick Verano Except Turbo or w/Dual Exhaust	24	40
		11-15	Chevrolet Cruze		15
		16	Chevrolet Cruze Limited Only (Old Body Style)		15
28	24883	12-16	KIA Rio 5 Dr. Hatchback	23	30
30	24884	12-16	Hyundai Accent 4 Dr. Sedan	26	15
		12-16	Hyundai Accent 5 Dr. Hatchback		15
		12-16	KIA Rio 4 Dr. Sedan		15
27	24885	08-16	Mitsubishi Lancer 4 Dr. Sedan, Except Evolution, Ralliart & w/Dual Exhaust	20	25
		10-14	Mitsubishi Lancer 5 Dr. Hatchback, Except Ralliart & w/Dual Exhaust		25
19	24886	08-16	Subaru Impreza 5 Dr. Wagon, Except WRX STI & w/Quad Exhaust Outlets	23	45
		13-15	Subaru XV Crosstrek Except Hybrid		45
		13-15	Subaru XV Crosstrek Hybrid		45
29	24887	12-17	Nissan Versa 4 Dr. Sedan	28	30
25	24888	12-16	Subaru Impreza 4 Dr. Sedan, Except WRX & WRX STI	31	30
23	24889	12-15	Toyota Prius C	14	20
30	24890	13-16	Dodge Dart	28	20
30	24892	11-16	Nissan JUKE FWD, Except Nismo & Nismo RS	25	25
24	24893	13-15	Chevrolet Spark Except w/Ground Effects	10	25
24	24894	13-15	Chevrolet Spark LT w/Ground Effects	20	25
29	24896	13-16	Ford C-MAX	19	25
19	24897	13-17	Ford Fusion Except Sport	23	20
		13-17	Lincoln MKZ		20
19	24899	09-14	Acura TL	14	45
		09-14	Acura TSX 4 Dr. Sedan		45
		08-16	Honda Accord Coupe		30
		08-16	Honda Accord Coupe		45
		13-15	Honda Accord Coupe, Except w/LED Taillights		30
		13-15	Honda Accord Coupe, w/LED Taillights		45
		08-17	Honda Accord Sedan		30
		13-15	Honda Accord Sedan, Except w/LED Taillights		45
		13-15	Honda Accord Sedan, w/LED Taillights		45
17	24902	13-15	Hyundai Elantra 2 Dr. Coupe	24	25
		11-16	Hyundai Elantra 4 Dr. Sedan		25
24	24903	14-17	KIA Forte 4 Dr. Sedan	14	20
28	24904	10-14	Volkswagen GTI Hatchback	14	40
		10-12	Volkswagen GTI Hatchback (Canada Only)		40
25	24905	13-16	Hyundai Elantra GT Except for Korean Manufactured Vehicles	18	25
28	24907	13-16	Nissan Sentra Except SR	21	35
25	24908	14-17	Mazda 6 4 Dr. Sedan	28	30
16	24909	14-16	Nissan Versa Note	20	30
31	24910	14-16	Ford Fiesta 4 Dr. Sedan	25	15
14	24911	07-14	Toyota Yaris 3 Dr. Liftback	18	20
		07-14	Toyota Yaris 5 Dr. Liftback, Except SE		20
25	24912	14-15	Mazda 3 4 Dr. Sedan	19	15
24	24913	03-17	Toyota Corolla	22	20

PC	PART NO.	YEARS	MAKE/MODEL	WGT LBS	IN
25	24914	14-17	Mazda 3 5 Dr. Hatchback	25	30
19	24915	14-16	KIA Soul Except w/LED Taillights	21	40
		14-16	KIA Soul w/LED Taillights		40
27	24916	14-15	Mitsubishi Mirage	20	20
		17	Mitsubishi Mirage Except Mirage G4		20
27	24919	15-16	Chrysler 200 4 Dr. Sedan	22	20
16	24920	15-16	Honda Fit	27	25
13	24921	14-16	Scion iC	19	15
28	24922	14-16	Volkswagen Beetle Except R-Line & GSR	25	20
25	24923	14-15	Lexus IS250	29	35
		14-16	Lexus IS350		35
29	24924	13-17	Cadillac ATS Except ATS-V	24	30
25	24925	15-16	Volkswagen Golf Except GTI & Sportwagen Models	15	60
33	24926	15-16	Volkswagen Jetta 4 Dr. Sedan, Except Hybrid & TDI	28	40
30	24927	14-15	Cadillac CTS 4 Dr. Sedan	17	60
		16-17	Cadillac CTS 4 Dr. Sedan, Except CTS-V		60
43	24928	15-17	Ford Mustang	36	30
16	24929	15-17	Toyota Yaris Except SE	19	25
27	24930	15-16	Audi A3 Except Sportback e-tron	22	20
27	24931	14-17	Infiniti Q50	25	40
18	24932	16-17	Honda HR-V	18	35
35	24933	16-17	Mazda CX-3	30	25
37	24934	11-16	MINI Cooper Countryman Except John Cooper Works Model	34	70
30	24935	13-16	Scion FR-S	25	75
		13-16	Subaru BRZ		75
		17	Toyota 86		75
32	24936	15-16	BMW 528i	25	50
		15-16	BMW 528i xDrive		50
		15-16	BMW 535d		50
		15-16	BMW 535d xDrive		50
		15-16	BMW 535i		50
		15-16	BMW 535i GT		50
		15-16	BMW 535i GT xDrive		50
		15-16	BMW 535i xDrive		50
		15-16	BMW 550i		50
		15-16	BMW 550i GT		50
		15-16	BMW 550i GT xDrive		50
		15-16	BMW 550i xDrive		50
24	24937	16	Honda Civic Sedan	24	65
23	24938	16-17	Chevrolet Camaro	21	50
15	24939	17	Hyundai Elantra	21	50
19	24940	11-17	Hyundai Sonata Except Hybrid	34	40
		11-16	Hyundai Sonata Hybrid		40
		11-16	KIA Optima		40
18	24941	16-17	Chevrolet Spark	21	45
29	24942	16-17	Acura TLX	16	60
18	24943	16	Chevrolet Cruze (New Body Style)	21	80
16	24944	16-17	Toyota Prius	20	45
24	24945	12-16	BMW 320i	21	50
		12-16	BMW 320i xDrive		50
		12-16	BMW 328d		50
		12-16	BMW 328d xDrive Sedan		50
		12-16	BMW 328d xDrive Sparts Wagon		50
		12-16	BMW 328i Sedan		50
		12-16	BMW 335i xDrive Sedan		50
24	24946	16	Honda Civic Coupe	24	65
		16	Honda Civic Sedan		65
18	24947	16-17	Chevrolet Volt	21	60
32	24948	16	Scion iA	26	30
		17	Toyota Yaris iA		30
19	24949	15-17	Volkswagen Golf SportWagen	20	60
24	24950	09-17	Audi A4 4 Dr. Sedan	32	25
18	24951	17	Chevrolet Cruze Hatchback	21	60
27	24953	15-17	Mercedes-Benz C300		75
CLASS I: INVISI-HITCH					
22	28501	04-06	Scion xB	21	25
CLASS II: 1-1/4" HITCH					
47	36105	77-83	Buick Estate Wagon	35	30
		77-90	Buick LeSabre Wagon		30
		91-95	Buick Roadmaster Estate Wagon		30
		77-96	Chevrolet Caprice Wagon		30
		77-92	Oldsmobile Custom Cruiser Wagon		30
		83-86	Pontiac Parisienne Wagon		30
		87-89	Pontiac Safari Wagon		30
39	36116	92-09	Ford Crown Victoria	33	30
		79-82	Ford LTD		30
		83-86	Ford LTD Country Squire Wagon		30

RECEIVER HITCH APPLICATION NUMERICAL

PC	PART NO.	YEARS	MAKE/MODEL	WGT LBS	IN				
39	36116	83-91	Ford LTD Crown Victoria	33	30				
		83-91	Ford LTD Crown Victoria Wagon						
		80-83	Lincoln Mark VI						
		81-11	Lincoln Town Car						
		87-91	Mercury Colony Park Wagon						
		83-11	Mercury Grand Marquis						
		83-86	Mercury Grand Marquis Colony Park Wagon						
		03-04	Mercury Marauder						
		79-82	Mercury Marquis Sedan						
		79-82	Mercury Marquis Wagon						
		45	36124			88-94	Buick Regal 2 Dr.	38	60
91-94	Buick Regal 4 Dr., Except GS/Limited								
90-94	Chevrolet Lumina Except Z-34								
88-93	Oldsmobile Cutlass Supreme 2 Dr. FWD								
92-97	Oldsmobile Cutlass Supreme 4 Dr. FWD								
88-90	Pontiac Grand Prix Except SE & Turbo								
91-93	Pontiac Grand Prix Except Turbo								
90-93	Chrysler Imperial			45	40				
87-95	Chrysler LeBaron 2 Dr. Coupe								
90-94	Chrysler LeBaron 4 Dr.								
86-88	Chrysler New Yorker								
90-93	Chrysler New Yorker Fifth Ave. FWD								
88-90	Chrysler New Yorker FWD Sedan								
90-93	Chrysler New Yorker Salon								
88-93	Dodge Dynasty								
89-95	Dodge Spirit								
89-95	Plymouth Acclaim								
40	36152†	87-95	Nissan Pathfinder			30	40		
43	36170	93-97	Chrysler Concorde	40	40				
		93-97	Chrysler Intrepid (Canada Only)						
		94-97	Chrysler LHS						
		94-96	Chrysler New Yorker						
		93-97	Dodge Intrepid						
93-97	Eagle Vision								
60	36173	89-93	Cadillac DeVille	43	40				
		89-93	Cadillac Fleetwood Coupe & Sedan, FWD						
41	36179	96-97	Ford Thunderbird	25	40				
		89-95	Ford Thunderbird Except SC						
		93-98	Lincoln Mark VIII						
		89-97	Mercury Cougar						
44	36183†	84-90	Dodge Caravan	30	30				
		91-93	Dodge Caravan C/V Long Wheelbase, 2 WD						
		94-95	Dodge Caravan C/V Long Wheelbase, 2 WD, Except LE						
		91-95	Dodge Caravan C/V Short Wheelbase						
		91-95	Dodge Caravan Short Wheelbase						
		87-93	Dodge Grand Caravan Long Wheelbase, 2 WD						
		94-95	Dodge Grand Caravan Long Wheelbase, 2 WD, Except LE						
		84-88	Dodge Mini Ram						
		87-90	Plymouth Grand Voyager						
		91-95	Plymouth Grand Voyager Long Wheelbase, 2 WD						
		84-90	Plymouth Voyager						
		91-95	Plymouth Voyager Short Wheelbase						
		43	36184†			94-96	Chevrolet Lumina APV	32	40
						94-96	Pontiac Trans Sport		
51	36185	94-96	Cadillac DeVille	37	40				
41	36188	85-96	Oldsmobile Cutlass Ciera FWD	32	40				
		85-91	Pontiac 6000 Except AWD						
30	36189	95-98	Ford Windstar	25	30				
		03	Ford Windstar (Built After 11/2002)						
		99-03	Ford Windstar (Built Before 11/2002)						
48	36193	95-00	Chevrolet Lumina	40	60				
		95-99	Chevrolet Monte Carlo						
33	36197	90-05	Chevrolet Astro Extended Body	38	30				
		85-94	Chevrolet Astro Standard Body						
		90-05	GMC Safari Extended Body						
		85-94	GMC Safari Standard Body						
34	36198	90-05	Chevrolet Astro Extended Body	32	30				
		85-94	Chevrolet Astro Standard Body						
		90-05	GMC Safari Extended Body						
		85-94	GMC Safari Standard Body						
35	36204	95-98	Honda Odyssey	28	30				
		96-99	Isuzu Oasis						
34	36206	96-14	Chevrolet Express 1500	25	15				
		96-17	Chevrolet Express 2500						
		96-17	Chevrolet Express 3500						
		96-14	GMC Savana 1500						
		96-17	GMC Savana 2500						

PC	PART NO.	YEARS	MAKE/MODEL	WGT LBS	IN				
34	36206	96-17	GMC Savana 3500	25	15				
		50	36211			96-99	Oldsmobile 88	34	30
						96-99	Oldsmobile LSS		
						97-98	Oldsmobile Regency		
96-99	Pontiac Bonneville Except SLE/SSE/SSEi								
43	36216	92-99	Buick LeSabre FWD	25	40				
		92-95	Oldsmobile 88						
		92-95	Pontiac Bonneville Except SSE & SSEi						
39	36222	97-03	Infiniti QX4	28	20				
		96-04	Nissan Pathfinder						
41	36226	96-04	Acura RL 3.5	28	30				
41	36233	97-05	Chevrolet Malibu 4 Dr.	34	20				
		97-99	Oldsmobile Cutlass 4 Dr., FWD						
48	36234	90-99	Subaru Legacy Coupe & Sedan	36	25				
		90-95	Subaru Legacy Wagon						
		96-99	Subaru Legacy Wagon, Except Outback						
		96-99	Subaru Legacy Wagon, Outback						
29	36238	97-06	Jeep TJ (Canada Only)	24	15				
		97-06	Jeep Wrangler						
51	36241	97-04	Buick Regal (App. starts with 97-1/2)	29	35				
		97-08	Pontiac Grand Prix						
40	36243	98-04	Cadillac Seville	24	35				
32	36244	95-05	Chevrolet Blazer Downsize	25	15				
		99-01	Chevrolet Blazer Trailblazer						
		95-05	GMC Jimmy Downsize						
		96-01	Oldsmobile Bravada						
47	36245	97-04	Buick Park Avenue	35	40				
32	36246	91-00	Ford Explorer	27	15				
		01-02	Ford Explorer 2 Dr. Sport						
		01	Ford Explorer 4 Dr.						
		91-94	Mazda Navajo						
		97-01	Mercury Mountaineer						
29	36247	98-01	Honda Passport w/Door Mounted Spare	26	15				
		98-00	Isuzu Amigo w/Door Mounted Spare						
		01-03	Isuzu Rodeo Sport 2 Dr., w/Door Mounted Spare						
		98-01	Isuzu Rodeo w/Door Mounted Spare						
34	36248	98-04	Chevrolet S10	25	35				
		83-97	Chevrolet S10 w/Standard Bed & Step Bumper						
		83-90	GMC S15 w/Standard Bed & Step Bumper						
		98-04	GMC Sonoma						
		96-00	Isuzu Hombre w/Step Bumper						
		86-03	Ford Taurus 4 Dr. Sedan			34	20		
96-99	Ford Taurus 4 Dr. Sedan, Except SHO								
96-99	Ford Taurus SHO	20	20						
86-03	Ford Taurus Wagon								
88-02	Lincoln Continental								
86-03	Mercury Sable Sedan								
86-03	Mercury Sable Wagon								
34	36260	84-01	Jeep Cherokee	23	30				
		84-90	Jeep Wagoneer						
41	36261	93-98	Mercury Villager	27	15				
		93-98	Nissan Quest						
29	36262	93-97	Volvo 850 Sedan	20	20				
		94-97	Volvo 850 Wagon						
		98-04	Volvo C70 Convertible						
		98-02	Volvo C70 Coupe						
		98-00	Volvo S70 Sedan						
		98-00	Volvo V70 Wagon						
		95-02	KIA Sportage			25	20		
50	36267	97-99	Cadillac DeVille	38	20				
37	36268	98-04	Chrysler Intrepid (Canada Only)	24	30				
		98-04	Dodge Intrepid						
42	36270†	98-01	Chrysler Concorde	33	35				
39	36271	99-03	Lexus RX300	34	15				
		01-03	Toyota Highlander						
36	36274	02-04	Chrysler Concorde	28	30				
		99-01	Chrysler LHS						
37	36275	99-01	Chrysler 300M	31	30				
		02-04	Chrysler 300M Except Special						
37	36276	99-04	Jeep Grand Cherokee	38	15				
39	36277	99-02	Mercury Villager	27	15				
		99-02	Nissan Quest						
34	36280	99-02	Saab 9-3	30	30				
		03	Saab 9-3 Convertible						
35	36282	00-06	Lincoln LS	27	30				
46	36284	00-04	Subaru Legacy Sedan, Except Outback	36	20				
		00-04	Subaru Legacy Wagon, Except Outback						

† = Available while supplies last.

RECEIVER HITCH APPLICATION NUMERICAL

PC	PART NO.	YEARS	MAKE/MODEL	WGT LBS	IN
46	36284	00-04	Subaru Outback Sedan, Except Sport	36	20
		00-04	Subaru Outback Wagon, Except Sport	20	20
41	36286	99-05	Saab 9-5	29	30
33	36287	00-05	Cadillac DeVille	30	20
		06-11	Cadillac DTS	20	20
42	36288	99-04	Oldsmobile Alero	33	20
		99-05	Pontiac Grand Am	20	20
45	36292	00-07	Chevrolet Monte Carlo Except SS Sport Appearance Pkg.	32	30
43	36293	00-04	Toyota Avalon	28	20
23	36296	96-03	Chrysler Town & Country	27	30
		04-07	Chrysler Town & Country Except w/Stow & Go Seats	30	30
		01-03	Chrysler Voyager	30	30
		96-03	Dodge Caravan	30	30
		04-07	Dodge Caravan Except w/Stow & Go Seats	30	30
		96-03	Dodge Grand Caravan	30	30
		04-07	Dodge Grand Caravan Except w/Stow & Go Seats	30	30
		96-00	Plymouth Grand Voyager	30	30
		96-00	Plymouth Voyager	30	30
37	36297	01-09	Volvo S60 Sedan	29	15
		01-07	Volvo V70 Wagon	15	15
		03-07	Volvo XC70 Wagon, AWD	15	15
34	36298	98-03	Toyota Sienna	24	15
45	36299†	00-03	Mazda MPV Except w/Ground Effects	40	15
40	36301	95-00	Chrysler Cirrus	35	60
		01-06	Chrysler Sebring 4 Dr.	60	60
		95-06	Dodge Stratus 4 Dr.	60	60
		96-00	Plymouth Breeze	60	60
37	36303	02-07	Jeep Liberty	30	15
45	36305	02-05	KIA Sedona	31	20
		00-05	Buick LeSabre	35	30
39	36309	06-09	Buick Lucerne Except Super & Special Edition	30	30
		01-03	Oldsmobile Aurora	30	30
		00-05	Pontiac Bonneville	30	30
20	36311	98-08	Subaru Forester	24	30
47	36313	00-06	Ford Taurus 4 Dr. Sedan	38	40
		00-06	Ford Taurus Wagon	40	40
		00-05	Mercury Sable Sedan	40	40
		00-05	Mercury Sable Wagon	40	40
43	36317	04-07	Chevrolet Malibu 4 Dr.	39	40
		08	Chevrolet Malibu Classic LS	40	40
		08	Chevrolet Malibu Classic LT	40	40
		06-07	Chevrolet Malibu SS 4 Dr.	50	40
41	36318	04-07	Ford Freestar	30	25
		04-07	Mercury Monterey	25	25
45	36320	05-07	Chrysler Town & Country w/Stow & Go Seats	38	25
		05-07	Dodge Grand Caravan w/Stow & Go Seats	25	25
35	36334	08-09	Subaru Legacy Sedan	26	25
		05-07	Subaru Legacy Sedan, Except Outback	25	25
		05-07	Subaru Legacy Wagon, Except Outback	25	25
		05-07	Subaru Outback Sedan, Except Sport	25	25
		05-09	Subaru Outback Wagon, Except Sport	25	25
23	36336	97-03	Lexus ES300 4 Dr.	34	15
		04-06	Lexus ES330 4 Dr.	15	15
		95-99	Toyota Avalon	15	15
		92-96	Toyota Camry	15	15
		97-06	Toyota Camry 4 Dr. Sedan	15	15
		99-03	Toyota Solara	15	15
		05-07	Ford Five Hundred	34	30
33	36360	05-07	Ford Freestyle	30	30
		08-09	Ford Taurus 4 Dr. Sedan	30	30
		08-09	Ford Taurus X	30	30
		05-07	Mercury Montego	30	30
		08-09	Mercury Sable Sedan	30	30
		05-07	Buick Terraza	26	40
		05-08	Chevrolet Uplander	40	40
		09	Chevrolet Uplander (Canada Only)	40	40
27	36361	97-05	Chevrolet Venture	40	40
		97-04	Oldsmobile Silhouette	40	40
		99-05	Pontiac Montana	40	40
		05-06	Pontiac Montana SV6	40	40
		07-09	Pontiac Montana SV6 (Canada Only)	40	40
		97-98	Pontiac Trans Sport	40	40
		05-07	Saturn Relay	40	40
		06-10	Jeep Commander	10	20
		05-10	Jeep Grand Cherokee Except SRT-8	90	90
		32	36363	05-09	Hyundai Tucson
05-10	KIA Sportage 4 Cyl.			25	25

PC	PART NO.	YEARS	MAKE/MODEL	WGT LBS	IN
32	36363	05-10	KIA Sportage 6 Cyl.	24	25
37	36374	05-09	Buick Allure (Canada Only)	28	30
		97-05	Buick Century Sedan	30	30
		05-09	Buick LaCrosse Except Super	30	30
		98-02	Oldsmobile Intrigue	30	30
39	36378	04-08	Toyota Solara	25	15
37	36379	04-07	Chevrolet Malibu Maxx LS	33	25
		04-07	Chevrolet Malibu Maxx LT	25	25
35	36407	00-13	Chevrolet Impala	38	30
18	36408	05-17	Chevrolet Equinox	28	25
		10-17	GMC Terrain	25	25
		06-09	Pontiac Torrent	25	25
		02-07	Saturn Vue Except Redline	25	25
20	36416	07-12	Lexus ES350	33	45
		07-11	Toyota Camry 4 Dr. Sedan, Except Hybrid	45	45
		07-11	Toyota Camry Hybrid 4 Dr. Sedan	45	45
32	36417	99-16	Honda Odyssey	38	20
34	36419	07-12	Mazda CX-7	28	40
22	36423	07-17	Jeep Compass	24	15
		07-17	Jeep Compass	30	30
		07-10	Jeep Compass Rallye Edition	30	30
		07-17	Jeep Patriot	15	15
		07-17	Jeep Patriot	30	30
27	36424	07-17	Jeep Wrangler Except w/Right Hand Drive, Hard Rock Edition, 75th Anniversary Edition & vehicles with Mopar Off Road Bumper #82213654	16	20
		07-17	Jeep Wrangler Right Hand Drive, Except Hard Rock Edition, 75th Anniversary Edition & vehicles with Mopar Off Road Bumper #82213654	20	20
34	36425	02-07	Buick Rendezvous	27	40
		01-05	Pontiac Aztek	40	40
36	36426	05-09	Pontiac G6	30	30
22	36427	07-09	Acura RDX	27	15
33	36447	07-10	Ford Edge Except Sport	34	45
		07-10	Lincoln MKX	45	45
31	36448	07-10	Chrysler Sebring Except Convertible	27	30
		08-10	Dodge Avenger	30	30
25	36450	08-09	Saturn Vue	28	15
31	36451	08-12	Jeep Liberty	31	15
24	36455	08-16	Chrysler Town & Country	34	20
		08-17	Dodge Grand Caravan	20	20
		12-15	RAM C/V Tradesman	20	20
		09-12	Volkswagen Routan	20	20
		13-14	Volkswagen Routan (Canada Only)	20	20
24	36466	07-16	Volvo S80 Sedan	24	35
10	36474	09-16	Volkswagen Tiguan	6	20
30	36477	09-16	Lincoln MKS	44	30
24	36479	08-12	Chevrolet Malibu Except LTZ	31	45
		08-12	Chevrolet Malibu LTZ	45	45
		07-09	Saturn Aura	45	45
30	36486	09-14	Hyundai Genesis 4 Dr. Sedan	29	60
		15	Hyundai Genesis 4 Dr. Sedan Excluding AWD	60	60
36	36492	10-16	Ford Taurus 4 Dr. Sedan	38	30
25	36493	10-17	Subaru Legacy Sedan	33	45
		10-17	Subaru Outback Wagon, Except Sport	45	45
22	36501	05-12	Ford Escape	32	20
		05-11	Mazda Tribute	20	20
		05-11	Mercury Mariner	20	20
25	36502	10-11	Buick Lucerne	36	25
		08-09	Buick Lucerne Super & Special Edition	25	25
25	36509	11-16	Mitsubishi Outlander Sport	26	30
		11-14	Mitsubishi RVR (Canada Only)	30	30
21	36510	10-15	Hyundai Tucson	33	20
		11-16	KIA Sportage	20	20
30	36511	10-12	Hyundai Santa Fe	38	15
		11-13	KIA Sorento EX V6, w/Factory Tow Package	15	15
		11-13	KIA Sorento Except SX V6 & EX V6 w/Factory Tow Package	15	15
		11-13	KIA Sorento SX V6	15	15
		09-16	Toyota Venza	32	20
27	36513	04-14	Toyota Sienna	26	20
		15-17	Toyota Sienna Except SE	20	20
		15-17	Toyota Sienna SE	20	20
16	36520	12-16	Honda CR-V	22	40
27	36521	09-13	Subaru Forester	30	35
49	36522	10-13	Buick LaCrosse	33	25
		11-13	Buick Regal Except GS	20	20
		13	Chevrolet Malibu (Canada Only)	20	20

† = Available while supplies last.

RECEIVER HITCH APPLICATION NUMERICAL

PC	PART NO.	YEARS	MAKE/MODEL	WGT LBS	IN
49	36522	13	Chevrolet Malibu Except LTZ & Canada Models	33	20
		13	Chevrolet Malibu LTZ Except Canada Models		20
21	36523	14-17	Subaru Forester	21	30
38	36524	13-17	Ford Escape	37	15
28	36525	14-16	KIA Rondo (Canada Only)	30	25
38	36529	13-17	Ford Escape	34	20
29	36530	13-17	Lexus ES350 Except Hybrid	32	40
32	36535	13	Lexus GS350	26	60
29	36536	13-17	Hyundai Santa Fe Sport (5 Passenger)	20	30
		14-15	KIA Sorento Except LX I4		30
		14-15	KIA Sorento LX I4		30
42	36538	10-16	Buick LaCrosse	39	35
		11-17	Buick Regal		35
		13-14	Cadillac XTS		35
		15-17	Chevrolet Impala		35
		14	Chevrolet Impala Except Impala Limited		35
		13-15	Chevrolet Malibu Except LTZ & Canada Models		35
		16	Chevrolet Malibu Limited LTZ, Except Canada Models (Old Body Style)		35
		16	Chevrolet Malibu Limited, Except LTZ & Canada Models (Old Body Style)		35
		14-15	Chevrolet Malibu LTZ Except Canada Models		35
23	36540	13-16	Toyota Avalon	35	40
		12-17	Toyota Camry Including Hybrid		40
46	36541	14-16	Acura RLX	19	60
18	36542	14-16	Nissan Rogue	28	15
		08-13	Nissan Rogue Except Krom		15
		14	Nissan Rogue Select		15
48	36543	14	Chevrolet Impala Eco, Except Impala Limited	37	30
		14	Chevrolet Impala LS Except Impala Limited		30
		14	Chevrolet Impala LT Except Impala Limited		30
		14	Chevrolet Impala LTZ Except Impala Limited		30
28	36544	12-16	Hyundai Azera	26	20
		14	KIA Cadenza		20
47	36546	14	Buick LaCrosse	35	30
27	36548	05-16	Chrysler 300	35	30
		05-16	Chrysler 300		40
		08-16	Dodge Challenger Except Models w/Quad Tip Exhaust		30
		06-16	Dodge Charger		30
		05-08	Dodge Magnum		30
25	36554	13-17	Buick Encore	26	40
		13-16	Chevrolet Trax		40
26	36572	16-17	Hyundai Tucson	26	30
37	36586	15-17	Lincoln MKC	41	45
27	36587	15-16	Jeep Renegade	33	30
24	36588	06-15	Toyota RAV4	28	20
23	36592	16-17	Chevrolet Malibu (New Body Style)	27	80
29	36593	17	KIA Sportage Except SX & SX Turbo	28	30
23	36594	17	Buick LaCrosse	26	80
23	36602	13-16	Mazda CX-5	28	30
46	36762	13-16	Cadillac XTS	39	30
		14	Chevrolet Impala LT Except Impala Limited		40
		14	Chevrolet Impala LTZ Except Impala Limited		40
24	36772	16	Mazda CX-9	37	30
26	36798	17	Chrysler Pacifica Except LX & Touring	42	45
		17	Chrysler Pacifica Except Touring L, Touring L Plus & Limited		45
CLASS III/IV: RECEIVER					
34	41001	63-86	Chevrolet C10	52	40
		63-86	Chevrolet C20		40
		88-91	Chevrolet C2500 Crew Cab		40
		63-86	Chevrolet C30		40
		63-86	Chevrolet C30		45
		88-91	Chevrolet C3500 Crew Cab		40
		63-86	Chevrolet K10		40
		63-86	Chevrolet K20		40
		88-91	Chevrolet K2500 Crew Cab		40
		73-86	Chevrolet K30		40
		88-91	Chevrolet K3500 Crew Cab		40
		63-72	Ford F-100		40
		63-74	Ford F-250		40
		63-74	Ford F-350		40
		99-00	Ford F-350 Super Duty Cab & Chassis, w/34" Wide Frames		40
		63-65	GMC 1000 Series		40
		63-65	GMC 1500 Series		40
		63-65	GMC 2500 Series		40
		63-66	GMC 3000		40
		63-66	GMC 3500		40

PC	PART NO.	YEARS	MAKE/MODEL	WGT LBS	IN
34	41001	75-78	GMC C15	52	40
		67-74	GMC C15/C1500		40
		79-86	GMC C1500		40
		67-78	GMC C25		40
		79-86	GMC C2500		40
		88-91	GMC C2500 Crew Cab		40
		67-78	GMC C35		40
		79-86	GMC C3500		40
		88-91	GMC C3500 Crew Cab		40
		67-78	GMC K15		40
		79-86	GMC K1500		40
		67-78	GMC K25		40
		79-86	GMC K2500		40
		67-78	GMC K35		40
		79-86	GMC K3500		40
		88-91	GMC K3500 Crew Cab		40
		74	International 100		30
		69-70	International 1000D		40
		71-73	International 1010		30
		69-70	International 1100D		30
		71-73	International 1110		30
		69-70	International 1200D		30
		71-73	International 1210		30
		69-70	International 1300D		30
		71-73	International 1310		30
		74-75	International 150		30
		69-71	International 1500D		30
		74-75	International 200		30
25	41004	80-83	Ford F-100 Except w/Custom Fascia	52	30
		87-96	Ford F-150		30
		80-86	Ford F-150 Except w/Custom Fascia		30
		87-96	Ford F-250		30
		80-86	Ford F-250 Except w/Custom Fascia		30
		97	Ford F-250 Heavy Duty		30
		87-96	Ford F-350		30
		80-86	Ford F-350 Except w/Custom Fascia		30
		97	Ford F-350 Heavy Duty		30
54	41015	96-97	Lexus LX450	40	30
		91-97	Toyota Land Cruiser		30
38	41116	92-09	Ford Crown Victoria	48	30
		79-82	Ford LTD		30
		83-91	Ford LTD Crown Victoria		30
		80-83	Lincoln Mark VI		30
		81-11	Lincoln Town Car		30
		83-11	Mercury Grand Marquis		30
		03-04	Mercury Marauder		30
		79-82	Mercury Marquis Sedan		30
52	41121	78-95	Chevrolet G10	50	30
		78-95	Chevrolet G20		30
		78-95	Chevrolet G30		30
		96	Chevrolet G30 Classic & Sport Full Size w/Lo-Mount Taillights		30
		79-95	GMC G1500		30
		79-95	GMC G2500		30
		79-95	GMC G3500		30
		96	GMC G3500 Vandura & Rally Full Size w/Lo-Mount Taillights		30
29	41504	63-86	Chevrolet C10 w/Deep Drop Bumper	67	40
		63-86	Chevrolet C20 w/Deep Drop Bumper		40
		88-91	Chevrolet C2500 Crew Cab, w/Deep Drop Bumper		40
		63-86	Chevrolet C30 w/Deep Drop Bumper		40
		88-91	Chevrolet C3500 Crew Cab, w/Deep Drop Bumper		40
		63-86	Chevrolet K10 w/Deep Drop Bumper		40
		63-86	Chevrolet K20 w/Deep Drop Bumper		40
		88-91	Chevrolet K2500 Crew Cab, w/Deep Drop Bumper		40
		73-86	Chevrolet K30 w/Deep Drop Bumper		40
		88-91	Chevrolet K3500 Crew Cab, w/Deep Drop Bumper		40
		68-89	Dodge D100 w/Deep Drop Bumper		40
		77-93	Dodge D150 w/Deep Drop Bumper		40
		68-80	Dodge D200 w/Deep Drop Bumper		40
		81-85	Dodge D250 w/Deep Drop Bumper		40
		68-80	Dodge D300 w/Deep Drop Bumper		40
		81-85	Dodge D350 w/Deep Drop Bumper		40
		94-01	Dodge Ram 1500 w/Deep Drop Bumper		40
		94-02	Dodge Ram 2500 w/Deep Drop Bumper		40
		94-02	Dodge Ram 3500 w/Deep Drop Bumper		40
		74-88	Dodge Ramcharger w/Deep Drop Bumper, Except w/Skid Shield		40
		67-89	Dodge W100 w/Deep Drop Bumper		40

RECEIVER HITCH APPLICATION NUMERICAL

PC	PART NO.	YEARS	MAKE/MODEL	WGT LBS	IN				
29	41504	77-93	Dodge W150 w/Deep Drop Bumper	67	40				
		67-80	Dodge W200 w/Deep Drop Bumper						
		81-93	Dodge W250 w/Deep Drop Bumper						
		67-80	Dodge W300 w/Deep Drop Bumper						
		81-93	Dodge W350 w/Deep Drop Bumper						
		78-86	Ford Bronco w/Deep Drop Bumper						
		89-97	Ford F Super Duty Cab & Chassis, w/34" Wide Frames & 161" Wheelbase & w/Deep Drop Bumper						
		63-79	Ford F-100 w/Deep Drop Bumper						
		80-83	Ford F-100 w/Deep Drop Bumper, Except w/Custom Fascia						
		75-96	Ford F-150 w/Deep Drop Bumper						
		80-86	Ford F-150 w/Deep Drop Bumper, Except w/Custom Fascia						
		97	Ford F-250 Heavy Duty, w/Deep Drop Bumper						
		63-96	Ford F-250 w/Deep Drop Bumper						
		80-86	Ford F-250 w/Deep Drop Bumper, Except w/Custom Fascia						
		97	Ford F-350 Heavy Duty, w/Deep Drop Bumper						
		99-00	Ford F-350 Super Duty Cab & Chassis, w/34" Wide Frames & w/Deep Drop Bumper						
		63-96	Ford F-350 w/Deep Drop Bumper						
		80-86	Ford F-350 w/Deep Drop Bumper, Except w/Custom Fascia						
		63-65	GMC 1000 Series w/Deep Drop Bumper						
		63-65	GMC 1500 Series w/Deep Drop Bumper						
		63-65	GMC 2500 Series w/Deep Drop Bumper						
		63-66	GMC 3000 w/Deep Drop Bumper						
		63-66	GMC 3500 w/Deep Drop Bumper						
		67-78	GMC C15 w/Deep Drop Bumper						
		79-86	GMC C1500 w/Deep Drop Bumper						
		67-78	GMC C25 w/Deep Drop Bumper						
		88-91	GMC C2500 Crew Cab, w/Deep Drop Bumper						
		79-86	GMC C2500 w/Deep Drop Bumper						
		67-78	GMC C35 w/Deep Drop Bumper						
		88-91	GMC C3500 Crew Cab, w/Deep Drop Bumper						
		79-86	GMC C3500 w/Deep Drop Bumper						
		67-78	GMC K15 w/Deep Drop Bumper						
		79-86	GMC K1500 w/Deep Drop Bumper						
		67-78	GMC K25 w/Deep Drop Bumper						
		79-86	GMC K2500 w/Deep Drop Bumper						
		67-78	GMC K35 w/Deep Drop Bumper						
		79-91	GMC K3500 w/Deep Drop Bumper						
		69-70	International 1000D w/Deep Drop Bumper						
		74-81	Plymouth Trailduster w/Deep Drop Bumper, Except w/Skid Shield						
		41	41511			99-00	Cadillac Escalade	46	30
						92-94	Chevrolet Blazer Full Size		
						92-99	Chevrolet Suburban C1500		
						92-99	Chevrolet Suburban C2500		
						92-99	Chevrolet Suburban K1500		
92-99	Chevrolet Suburban K2500								
95-00	Chevrolet Tahoe								
92-99	GMC Suburban C1500								
92-99	GMC Suburban C2500								
92-99	GMC Suburban K1500								
92-99	GMC Suburban K2500								
92-00	GMC Yukon								
99-00	GMC Yukon Denali								
33	41521	96-14	Chevrolet Express 1500	46	15				
		96-17	Chevrolet Express 2500						
		96-17	Chevrolet Express 3500						
		96-14	GMC Savana 1500						
		96-17	GMC Savana 2500						
		96-17	GMC Savana 3500						
		38	41522			88-99	Chevrolet C1500 w/Aftermarket Roll Pan	27	40
88-99	Chevrolet C2500 w/Aftermarket Roll Pan								
88-00	Chevrolet C3500 w/Aftermarket Roll Pan								
88-99	Chevrolet K1500 w/Aftermarket Roll Pan								
88-99	Chevrolet K2500 w/Aftermarket Roll Pan								
88-00	Chevrolet K3500 w/Aftermarket Roll Pan								
88-99	GMC C1500 w/Aftermarket Roll Pan								
88-00	GMC C2500 w/Aftermarket Roll Pan								
88-00	GMC C3500 w/Aftermarket Roll Pan								
88-99	GMC K1500 w/Aftermarket Roll Pan								
88-00	GMC K2500 w/Aftermarket Roll Pan								
88-00	GMC K3500 w/Aftermarket Roll Pan								
44	41524			88-99	Chevrolet C1500	48	20		
				92-00	Chevrolet C2500 Crew Cab				
				88-99	Chevrolet C2500 Regular & Extended Cabs				
				92-00	Chevrolet C3500 Crew Cab				

PC	PART NO.	YEARS	MAKE/MODEL	WGT LBS	IN
44	41524	88-00	Chevrolet C3500 Regular & Extended Cabs	48	20
		88-99	Chevrolet K1500		
		92-00	Chevrolet K2500 Crew Cab		
		88-99	Chevrolet K2500 Regular & Extended Cabs		
		92-00	Chevrolet K3500 Crew Cab		
		88-00	Chevrolet K3500 Regular & Extended Cabs		
		88-99	GMC C1500		
		88-00	GMC C2500		
		88-00	GMC C3500		
		88-99	GMC K1500		
		88-00	GMC K2500		
		88-00	GMC K3500		
38	41525	88-99	Chevrolet C1500	53	20
		92-00	Chevrolet C2500 Crew Cab		
		88-99	Chevrolet C2500 Regular & Extended Cabs		
		92-00	Chevrolet C3500 Crew Cab		
		88-00	Chevrolet C3500 Regular & Extended Cabs		
		88-99	Chevrolet K1500		
		92-00	Chevrolet K2500 Crew Cab		
		88-99	Chevrolet K2500 Regular & Extended Cabs		
		92-00	Chevrolet K3500 Crew Cab		
		88-00	Chevrolet K3500 Regular & Extended Cabs		
41	41527	97-02	Ford Expedition	54	15
		98-02	Lincoln Navigator		
53	41528	88-99	Chevrolet C1500 w/10" Deep Drop Bumper	50	20
		92-00	Chevrolet C2500 Crew Cab w/10" Deep Drop Bumper		
		88-99	Chevrolet C2500 Regular & Extended Cabs, w/10" Deep Drop Bumper		
		92-00	Chevrolet C3500 Crew Cab w/10" Deep Drop Bumper		
		88-00	Chevrolet C3500 Regular & Extended Cabs, w/10" Deep Drop Bumper		
		88-99	Chevrolet K1500 w/10" Deep Drop Bumper		
		92-00	Chevrolet K2500 Crew Cab w/10" Deep Drop Bumper		
		88-99	Chevrolet K2500 Regular & Extended Cabs, w/10" Deep Drop Bumper		
		92-00	Chevrolet K3500 Crew Cab w/10" Deep Drop Bumper		
		88-00	Chevrolet K3500 Regular & Extended Cabs, w/10" Deep Drop Bumper		
31	41531	97-06	Jeep TJ (Canada Only)	26	15
		97-06	Jeep Wrangler		
37	41533	94	Dodge Van, B150	50	20
		95-98	Dodge Van, B1500		
		94	Dodge Van, B250		
		95-98	Dodge Van, B2500		
		94	Dodge Van, B350		
		95-98	Dodge Van, B3500		
		99-03	Dodge Van, Ram 1500		
99-03	Dodge Van, Ram 2500				
99-03	Dodge Van, Ram 3500				
39	41534	99-02	Chevrolet Silverado 1500	52	20
		03-07	Chevrolet Silverado 1500 (Classic)		
		01-02	Chevrolet Silverado 1500 HD		
		03-07	Chevrolet Silverado 1500 HD (Classic)		
		99-04	Chevrolet Silverado 2500		
		99-02	GMC Sierra 1500		
		03-07	GMC Sierra 1500 (Classic)		
		01-03	GMC Sierra 1500 HD		
		05-07	GMC Sierra 1500 HD (Classic)		
		99-04	GMC Sierra 2500		
56	41536	94-01	Dodge Ram 1500	46	15
		94-02	Dodge Ram 2500		
		94-02	Dodge Ram 3500		
29	41537	99-04	Chevrolet Tracker	29	15
		99-05	Suzuki Grand Vitara		
		99-04	Suzuki Vitara		

RECEIVER HITCH APPLICATION NUMERICAL

PC	PART NO.	YEARS	MAKE/MODEL	WGT LBS	IN		
29	41537	02-06	Suzuki XL-7	29	15		
35	41541	99-03	Lexus RX300	34	15		
		01-03	Toyota Highlander		15		
25	41543	01-06	Hyundai Santa Fe	28	35		
46	41544	01-02	Chevrolet Silverado 2500 HD	55	20		
		03-07	Chevrolet Silverado 2500 HD (Classic)		20		
		01-02	Chevrolet Silverado 3500		20		
		03-07	Chevrolet Silverado 3500 (Classic)		20		
		01-02	GMC Sierra 2500 HD		20		
		03-07	GMC Sierra 2500 HD (Classic)		20		
		01-02	GMC Sierra 3500		20		
		03-07	GMC Sierra 3500 (Classic)		20		
30	41547	99-00	Ford F-350 Super Duty Cab & Chassis, w/34" Wide Frames	60	60		
		99-16	Ford F-450 Super Duty Cab & Chassis, w/34" Wide Frames		60		
		99-16	Ford F-550 Super Duty Cab & Chassis, w/34" Wide Frames		60		
56	41549	04-05	Ford F-150	55	30		
		06	Lincoln Mark LT (Built Before 8/2005)		30		
38	41551	04-15	Nissan Titan	40	15		
36	75020	87-95	Nissan Pathfinder	38	40		
62	75031	84-95	Toyota Pickup Except T-100	60	60		
35	75033	88-99	Chevrolet C1500	46	20		
		92-00	Chevrolet C2500 Crew Cab		20		
		88-99	Chevrolet C2500 Regular & Extended Cabs		20		
		92-00	Chevrolet C3500 Crew Cab		20		
		88-00	Chevrolet C3500 Regular & Extended Cabs		20		
		88-99	Chevrolet K1500		20		
		92-00	Chevrolet K2500 Crew Cab		20		
		88-99	Chevrolet K2500 Regular & Extended Cabs		20		
		92-00	Chevrolet K3500 Crew Cab		20		
		88-00	Chevrolet K3500 Regular & Extended Cabs		20		
		88-99	GMC C1500		20		
		88-00	GMC C2500		20		
		88-00	GMC C3500		20		
		88-99	GMC K1500		20		
		88-00	GMC K2500		20		
		88-00	GMC K3500		20		
		34	75034	63-86	Chevrolet C10	36	30
				63-86	Chevrolet C10		40
63-86	Chevrolet C20				30		
63-86	Chevrolet C20				40		
88-91	Chevrolet C2500 Crew Cab				30		
63-86	Chevrolet C30				30		
63-86	Chevrolet C30				40		
88-91	Chevrolet C3500 Crew Cab				30		
63-86	Chevrolet K10				30		
63-86	Chevrolet K10				40		
63-86	Chevrolet K20				30		
63-86	Chevrolet K20				40		
88-91	Chevrolet K2500 Crew Cab				30		
73-86	Chevrolet K30				40		
88-91	Chevrolet K3500 Crew Cab				30		
63-72	Ford F-100				30		
63-72	Ford F-250				30		
63-74	Ford F-350				30		
63-65	GMC 1000 Series				30		
63-65	GMC 1500 Series				30		
63-65	GMC 2500 Series				30		
63-66	GMC 3000				30		
63-66	GMC 3500				30		
75-78	GMC C15				40		
67-74	GMC C15/C1500				30		
79-86	GMC C1500				40		
67-78	GMC C25				40		
79-86	GMC C2500				40		
88-91	GMC C2500 Crew Cab				30		
67-78	GMC C35				40		
79-86	GMC C3500				40		
88-91	GMC C3500 Crew Cab				30		
67-78	GMC K15				30		
67-78	GMC K15				40		
79-86	GMC K1500				40		
67-78	GMC K25				40		
79-86	GMC K2500				40		
67-78	GMC K35				40		
79-86	GMC K3500				40		
88-91	GMC K3500 Crew Cab				30		
74	International 100				30		

PC	PART NO.	YEARS	MAKE/MODEL	WGT LBS	IN
34	75034	69-70	International 1000D	36	30
		71-73	International 1010		30
		69-70	International 1100D		30
		71-73	International 1110		30
		69-70	International 1200D		30
		71-73	International 1210		30
		69-70	International 1300D		30
		71-73	International 1310		30
		74-75	International 150		30
		69-71	International 1500D		30
		74-75	International 200		30
37	75037	99-00	Cadillac Escalade	40	30
		92-94	Chevrolet Blazer Full Size		30
		92-99	Chevrolet Suburban C1500		30
		92-99	Chevrolet Suburban C2500		30
		92-99	Chevrolet Suburban K1500		30
		92-99	Chevrolet Suburban K2500		30
		95-00	Chevrolet Tahoe		30
		92-99	GMC Suburban C1500		30
		92-99	GMC Suburban C2500		30
		92-99	GMC Suburban K1500		30
		92-00	GMC Yukon		30
99-00	GMC Yukon Denali		30		
34	75038	68-79	Dodge D100	38	30
		77-93	Dodge D150		30
		68-80	Dodge D200		30
		81-93	Dodge D250		30
		68-80	Dodge D300		30
		81-93	Dodge D350		30
		97-04	Dodge Dakota		30
		67-89	Dodge W100		30
		77-93	Dodge W150		30
		67-80	Dodge W200		30
		81-93	Dodge W250		30
		67-80	Dodge W300		30
		81-93	Dodge W350		30
		78-96	Ford Bronco		30
		75-79	Ford F-100		30
		80-83	Ford F-100 Except w/Custom Fascia		30
		87-96	Ford F-150		30
		80-86	Ford F-150 Except w/Custom Fascia		30
		75-96	Ford F-250		30
		80-86	Ford F-250 Except w/Custom Fascia		30
		97	Ford F-250 Heavy Duty		30
75-96	Ford F-350		30		
80-86	Ford F-350 Except w/Custom Fascia		30		
97	Ford F-350 Heavy Duty		30		
30	75041	93-98	Jeep Grand Cherokee	40	40
		93	Jeep Grand Wagoneer		40
41	75043	96-99	Acura SLX	41	40
		92-02	Isuzu Trooper		40
39	75049	94-97	Honda Passport	34	40
		91-97	Isuzu Rodeo		40
34	75051	83-97	Chevrolet S10 w/Standard Bed & Step Bumper	37	40
		83-90	GMC S15 w/Standard Bed & Step Bumper		40
		96-97	Isuzu Hombre w/Step Bumper		40
30	75054	84-01	Jeep Cherokee	36	40
		84-90	Jeep Wagoneer		40
43	75055	95-98	Ford Windstar	38	40
		03	Ford Windstar (Built After 11/2002)		40
		99-03	Ford Windstar (Built Before 11/2002)		40
28	75065	97-03	Ford F-150 Flareside	44	30
		04	Ford F-150 Heritage Flareside		30
		04	Ford F-150 Heritage Styleside		30
		97-03	Ford F-150 Styleside		30
		00-03	Ford F-150 SuperCrew		30
97-99	Ford F-250 Styleside		30		
42	75071	97-02	Ford Expedition	47	15
		98-02	Lincoln Navigator		15
31	75073	87-04	Dodge Dakota	39	15
		87-04	Dodge Dakota		30
40	75075	97-04	Mitsubishi Montero Sport	34	20
34	75077	97-03	Infiniti QX4	32	20
		96-04	Nissan Pathfinder		20
32	75078	95-04	Toyota Tacoma (App. starts with 95-1/2)	42	40
21	75079	95-05	Chevrolet Blazer Downsize	29	15

RECEIVER HITCH APPLICATION NUMERICAL

PC	PART NO.	YEARS	MAKE/MODEL	WGT LBS	IN
21	75079	99-01	Chevrolet Blazer Trailblazer	29	15
		95-05	GMC Jimmy Downsize		
		96-01	Oldsmobile Bravada		
34	75081	98-03	Dodge Durango	44	15
24	75082	93-11	Ford Ranger	30	20
		83-92	Ford Ranger Except GT		
		94-09	Mazda B2300		
		98-01	Mazda B2500		
		94-08	Mazda B3000		
		94-09	Mazda B4000		
34	75083	91-00	Ford Explorer	30	15
		01-02	Ford Explorer 2 Dr. Sport		
		01	Ford Explorer 4 Dr.		
		91-94	Mazda Navajo		
		97-01	Mercury Mountaineer		
30	75085	98-04	Chevrolet S10	35	40
		96-97	Chevrolet S10 w/Sportside Bed & Non-Towing Bumper		
		98-04	GMC Sonoma		
		96-97	GMC Sonoma w/Sportside Bed & Non-Towing Bumper		
		98-00	Isuzu Hombre w/Step Bumper		
34	75087	98-02	Mercedes-Benz ML320	21	30
		03-05	Mercedes-Benz ML350		
		99-01	Mercedes-Benz ML430		
		02-05	Mercedes-Benz ML500		
47	75089	93-98	Mercury Villager	37	15
		93-98	Nissan Quest		
41	75090	94	Dodge Van, B150	41	20
		95-98	Dodge Van, B1500		
		94	Dodge Van, B250		
		95-98	Dodge Van, B2500		
		94	Dodge Van, B350		
		95-98	Dodge Van, B3500		
		99-03	Dodge Van, Ram 1500		
		99-03	Dodge Van, Ram 2500		
		99-03	Dodge Van, Ram 3500		
42	75091	96-02	Toyota 4Runner	40	30
34	75092	98-01	Honda Passport w/Door Mounted Spare	34	15
		98-01	Isuzu Rodeo w/Door Mounted Spare		
30	75093	98-02	Honda Passport w/Under Vehicle Spare	30	15
		02-03	Isuzu Axiom w/Under Vehicle Spare		
		98-04	Isuzu Rodeo w/Under Vehicle Spare, Except w/3.5L		
45	75095	98-07	Lexus LX470	36	20
		98-07	Toyota Land Cruiser		
31	75096	91-00	Ford Explorer	38	15
		91-00	Ford Explorer		
		01-02	Ford Explorer 2 Dr. Sport		
		01	Ford Explorer 4 Dr.		
		91-94	Mazda Navajo		
		97-01	Mercury Mountaineer		
		88-99	Chevrolet C1500		
92-00	Chevrolet C2500 Crew Cab				
88-99	Chevrolet C2500 Regular & Extended Cabs				
92-00	Chevrolet C3500 Crew Cab				
88-00	Chevrolet C3500 Regular & Extended Cabs				
88-99	Chevrolet K1500				
92-00	Chevrolet K2500 Crew Cab				
88-99	Chevrolet K2500 Regular & Extended Cabs				
92-00	Chevrolet K3500 Crew Cab				
88-99	GMC C1500				
88-00	GMC C2500				
88-00	GMC C3500				
88-99	GMC K1500				
88-00	GMC K2500				
88-00	GMC K3500				
25	75101	94-01	Dodge Ram 1500	38	15
		94-02	Dodge Ram 2500		
		94-02	Dodge Ram 3500		
44	75102	99-02	Mercury Villager	32	15
		99-02	Nissan Quest		
30	75105	00-06	Toyota Tundra Except Models w/Towable Bumper	50	15
41	75107	00-04	Nissan Xterra	28	15
46	75108	00-03	Mazda MPV Except w/Ground Effects	49	15
32	75112	01-05	Ford Explorer Sport Trac	38	15
50	75116	01-06	Mitsubishi Montero Except Montero Sport	40	20
38	75118	01-04	Ford Escape	31	35
		01-04	Mazda Tribute		
30	75119	96-03	Chrysler Town & Country	38	30

PC	PART NO.	YEARS	MAKE/MODEL	WGT LBS	IN				
30	75119	04-07	Chrysler Town & Country Except w/Stow & Go Seats	38	30				
		01-03	Chrysler Voyager						
		96-03	Dodge Caravan						
		04-07	Dodge Caravan Except w/Stow & Go Seats						
		96-03	Dodge Grand Caravan						
		04-07	Dodge Grand Caravan Except w/Stow & Go Seats						
		96-00	Plymouth Grand Voyager						
		96-00	Plymouth Voyager						
		34	75120			98-03	Toyota Sienna	33	30
		45	75121			78-95	Chevrolet G10	45	40
78-95	Chevrolet G20								
78-95	Chevrolet G30								
96	Chevrolet G30 Classic & Sport Full Size w/Lo-Mount Taillights								
79-95	GMC G1500								
79-95	GMC G2500								
33	75122	79-95	GMC G3500	47	30				
		96	GMC G3500 Vandura & Rally Full Size w/Lo-Mount Taillights						
		90-05	Chevrolet Astro Extended Body						
42	75123†	90-05	GMC Safari Extended Body	32	60				
		83-94	Chevrolet Blazer S10						
31	75125	84-91	Chevrolet Blazer S10 2 Dr.	25	15				
		84-91	Chevrolet Blazer S10 4 Dr.						
		92-94	GMC Jimmy Downsize						
		83	GMC S15 Jimmy						
		84-91	GMC S15 Jimmy 2 Dr.						
		84-91	GMC S15 Jimmy 4 Dr.						
		91-94	Oldsmobile Bravada						
		57	75126			01-07	Toyota Sequoia	42	20
		23	75128			02-07	Jeep Liberty	39	15
44	75129	73-91	Chevrolet Blazer Full Size	34	30				
		75-86	Chevrolet Blazer K5						
		73-91	GMC Jimmy Full Size						
42	75131	02-05	KIA Sedona	33	30				
51	75132	02-05	Ford Explorer 4 Dr.	38	20				
		03-05	Lincoln Aviator						
		02-05	Mercury Mountaineer						
14	75135	02-03	Dodge Ram 1500 (Built Before 11/2002)	22	15				
33	75138	02-07	Buick Rendezvous	38	55				
		01-05	Pontiac Aztek						
31	75139	99-04	Jeep Grand Cherokee	43	15				
30	75140	78-80	Dodge Van, B100	41	30				
		81-94	Dodge Van, B150						
		95-98	Dodge Van, B1500						
		78-80	Dodge Van, B200						
		81-94	Dodge Van, B250						
		95-98	Dodge Van, B2500						
		78-80	Dodge Van, B300						
		81-94	Dodge Van, B350						
		95-98	Dodge Van, B3500						
		99-03	Dodge Van, Ram 1500						
		99-03	Dodge Van, Ram 2500						
99-03	Dodge Van, Ram 3500								
59	75144	93-98	Toyota T100	49	45				
53	75145	92-95	Toyota 4Runner	52	40				
37	75148	03-07	Nissan Murano	32	30				
11	75151	06-08	Dodge Ram 1500	14	20				
		03	Dodge Ram 1500 (Built After 11/2002)						
		04-05	Dodge Ram 1500 Except Daytona/Hemi Sport Quad Cab/Ram Rumble Bee/SRT-10						
		03-09	Dodge Ram 2500						
		03-09	Dodge Ram 3500						
36	75152	03-14	Volvo XC90	29	25				
32	75153	04-06	Lexus RX330	37	20				
		07-09	Lexus RX350						
		06-08	Lexus RX400h Hybrid						
		04-07	Toyota Highlander						
47	75155	03-09	Lexus GX470	31	35				
		03-09	Toyota 4Runner						
50	75156	04-05	Ford F-150	48	30				
		06	Lincoln Mark LT (Built Before 8/2005)						
45	75158	04-07	Ford Freestar	33	30				
		04-07	Mercury Monterey						
50	75159	04-09	Nissan Quest	46	20				
18	75162	07-09	Chrysler Aspen	25	50				
		04-09	Dodge Durango						

† = Available while supplies last.

RECEIVER HITCH APPLICATION NUMERICAL

PC	PART NO.	YEARS	MAKE/MODEL	WGT LBS	IN		
41	75163	04-05	Mitsubishi Endeavor	27	20		
35	75172	03-06	Cadillac Escalade	31	30		
		03-06	Cadillac Escalade ESV	30	30		
		03-06	Cadillac Escalade EXT	30	30		
		04-09	Cadillac SRX Except w/Sport Package Fascia	56	60		
47	75176†	90-95	Chrysler Town & Country 2 WD Long Wheelbase	29	30		
		91-93	Dodge Caravan C/V Long Wheelbase, 2 WD	30	30		
		94-95	Dodge Caravan C/V Long Wheelbase, 2 WD, Except LE	30	30		
		91-95	Dodge Caravan C/V Short Wheelbase, 2 WD	30	30		
		84-95	Dodge Caravan Short Wheelbase, 2 WD	30	30		
		87-93	Dodge Grand Caravan Long Wheelbase, 2 WD	30	30		
		94-95	Dodge Grand Caravan Long Wheelbase, 2 WD, Except LE	30	30		
		84-88	Dodge Mini Ram	30	30		
		87-90	Plymouth Grand Voyager	30	30		
		91-95	Plymouth Grand Voyager Long Wheelbase, 2 WD	30	30		
		84-90	Plymouth Voyager	30	30		
		91-95	Plymouth Voyager Short Wheelbase, 2 WD	30	30		
		41	75186	88-94	Nissan D21	49	30
				98-04	Nissan Frontier	30	30
				95-97	Nissan Pickup	30	30
22	75189	96-14	Chevrolet Express 1500	39	15		
		96-17	Chevrolet Express 2500	15	15		
		96-17	Chevrolet Express 3500	15	15		
		96-14	GMC Savana 1500	15	15		
		96-17	GMC Savana 2500	15	15		
		96-17	GMC Savana 3500	15	15		
28	75193	97-06	Jeep TJ (Canada Only)	31	15		
		97-06	Jeep Wrangler	15	15		
48	75210	03-06	Dodge Sprinter 2500 w/41" Wide Frames, Except 118" Wheelbase & Factory Metal Step Platform	41	20		
		03-06	Dodge Sprinter 3500 w/41" Wide Frames, Except 118" Wheelbase & Factory Metal Step Platform	20	20		
		03-06	Freightliner Sprinter 2500 w/41" Wide Frames, Except 118" Wheelbase & Factory Metal Step Platform	20	20		
		03-06	Freightliner Sprinter 3500 w/41" Wide Frames, Except 118" Wheelbase & Factory Metal Step Platform	20	20		
28	75214	15-16	Ford Edge Except Sport & Titanium Models	33	30		
		15	Ford Edge Titanium Model Only	30	30		
45	75216	15-17	Ford F-150	42	30		
24	75217	13-16	Mazda CX-5	30	30		
43	75218	13-17	Audi Q3	40	50		
37	75219	15-17	RAM ProMaster City	30	60		
35	75220	13-15	Isuzu MU-X	43	45		
36	75223	15-17	Mercedes-Benz GLA250	34	90		
37	75225	14-17	Acura MDX	40	20		
		16	Honda Pilot	20	20		
25	75227	12-16	Land Rover Range Rover Evoque Excluding Autobiography	31	45		
41	75229	15-16	Land Rover Range Rover Sport	35	45		
39	75232	11-17	RAM 1500	40	40		
35	75234	15-16	Ford Edge Except Sport & Titanium Models	35	45		
		15-16	Ford Edge Titanium and Sport Models Only	45	45		
		16	Lincoln MKX	45	45		
20	75235	06-17	Toyota RAV4	39	20		
18	75236	05-15	Toyota Tacoma Except X-Runner	37	30		
24	75237	04-14	Toyota Sienna	39	30		
		15-17	Toyota Sienna Except SE	30	30		
		15-17	Toyota Sienna SE	30	30		
20	75238	16-17	Toyota Tacoma	35	20		
27	75251	05-10	Dodge Dakota	36	20		
		06-09	Mitsubishi Raider	20	20		
		11	RAM Dakota	20	20		
21	75270	99-16	Honda Odyssey	44	15		
22	75278	05-07	Buick Terraza	39	40		
		05-08	Chevrolet Uplander	40	40		
		09	Chevrolet Uplander (Canada Only)	40	40		
		97-05	Chevrolet Venture	40	40		
		97-04	Oldsmobile Silhouette	40	40		
		99-05	Pontiac Montana	40	40		
		05-06	Pontiac Montana SV6	40	40		
		07-09	Pontiac Montana SV6 (Canada Only)	40	40		
		97-98	Pontiac Trans Sport	40	40		
		05-07	Saturn Relay	40	40		
		40	75280	06-14	Honda Ridgeline	38	20
20	75282	05-16	Nissan Frontier	40	30		
		09-12	Suzuki Equator	30	30		
37	75291	05-15	Nissan Xterra	28	30		
39	75292	04-06	Dodge Durango	44	20		

PC	PART NO.	YEARS	MAKE/MODEL	WGT LBS	IN
42	75299	05-07	Ford Five Hundred	42	30
		05-07	Ford Freestyle	30	30
		08-09	Ford Taurus 4 Dr. Sedan	30	30
		08-09	Ford Taurus X	30	30
		05-07	Mercury Montego	30	30
08-09	75305	06-10	Mercury Sable Sedan	30	30
		05-07	Chrysler Town & Country w/Stow & Go Seats	47	25
54	75305	05-07	Dodge Grand Caravan w/Stow & Go Seats	25	25
		06-10	Jeep Commander	26	20
19	75338	05-10	Jeep Grand Cherokee Except SRT-8	90	90
		99-13	Chevrolet Silverado 1500	40	15
30	75362	03-07	Chevrolet Silverado 1500 (Classic)	15	15
		01-03	Chevrolet Silverado 1500 HD	15	15
		05-07	Chevrolet Silverado 1500 HD (Classic)	15	15
		99-04	Chevrolet Silverado 2500	15	15
		99-13	GMC Sierra 1500	15	15
		03-07	GMC Sierra 1500 (Classic)	15	15
		01-03	GMC Sierra 1500 HD	15	15
		05-07	GMC Sierra 1500 HD (Classic)	15	15
		99-04	GMC Sierra 2500	15	15
		99-04	GMC Sierra 2500	15	15
47	75363	04-10	Volkswagen Touareg	34	90
25	75371	04-10	BMW X3	25	100
50	75376	07-08	Mercedes-Benz ML320 CDI Except w/Adaptive Variable Suspension	41	50
		10-11	Mercedes-Benz ML350 Except BlueTEC or w/Adaptive Variable Suspension	50	50
		06-09	Mercedes-Benz ML350 Except w/Adaptive Variable Suspension	50	50
		10-11	Mercedes-Benz ML450 Hybrid, Except w/Adaptive Variable Suspension	50	50
		06-07	Mercedes-Benz ML500 Except w/Adaptive Variable Suspension	50	50
08-11	Mercedes-Benz ML550 Except w/Adaptive Variable Suspension	50	50		
43	75382	06-10	Hummer H3	35	25
33	75401	06-07	Subaru B9 Tribeca	32	35
		08-10	Subaru Tribeca	35	35
46	75420	06-08	Dodge Ram 1500	49	25
		03	Dodge Ram 1500 (Built After 11/2002)	25	25
		04-05	Dodge Ram 1500 Except Daytona/Hemi Sport Quad Cab/Ram Rumble Bee/SRT-10	25	25
		03-09	Dodge Ram 2500	25	25
		03-09	Dodge Ram 3500	25	25
45	75421	07-09	Hyundai Entourage	35	20
		06-14	KIA Sedona 118.9" Long Wheelbase	20	20
28	75430	02-07	Buick Rendezvous	33	40
		01-05	Pontiac Aztek	40	40
39	75437	06-10	Ford Explorer w/1-1/4" Receivers	34	25
		06-10	Mercury Mountaineer w/1-1/4" Receivers	25	25
30	75448	06-13	Suzuki Grand Vitara	30	20
34	75461	07-14	Toyota FJ Cruiser	34	30
43	75470	09	Mercedes-Benz R320 BlueTEC	45	25
		09	Mercedes-Benz R320 BlueTEC w/Panoramic Roof Package	50	25
		07-08	Mercedes-Benz R320 CDI	25	25
		07-08	Mercedes-Benz R320 CDI w/Panoramic Roof Package	50	25
		06-12	Mercedes-Benz R350	25	25
		06-12	Mercedes-Benz R350 w/Panoramic Roof Package	50	25
		06-07	Mercedes-Benz R500	25	25
06-07	Mercedes-Benz R500 w/Panoramic Roof Package	50	25		
37	75471	07-09	Hyundai Santa Fe	43	20
28	75492	00-06	BMW X5	26	60
45	75500	73-86	Chevrolet Suburban C10	34	20
		73-86	Chevrolet Suburban C10	40	40
		73-86	Chevrolet Suburban C20	20	20
		73-86	Chevrolet Suburban C20	40	40
		73-86	Chevrolet Suburban K10	20	20
		73-86	Chevrolet Suburban K10	40	40
		73-86	Chevrolet Suburban K20	20	20
		73-86	Chevrolet Suburban K20	40	40
		87-88	Chevrolet Suburban R10	20	20
		89-91	Chevrolet Suburban R1500	20	20
		87-88	Chevrolet Suburban R20	20	20
		89-91	Chevrolet Suburban R2500	20	20
		87-88	Chevrolet Suburban V10	20	20
89-91	Chevrolet Suburban V1500	20	20		
87-88	Chevrolet Suburban V20	20	20		
89-91	Chevrolet Suburban V2500	20	20		
73-78	GMC Suburban C15	40	40		
79-86	GMC Suburban C1500	20	20		
79-86	GMC Suburban C1500	40	40		

† = Available while supplies last.

RECEIVER HITCH APPLICATION NUMERICAL

PC	PART NO.	YEARS	MAKE/MODEL	WGT LBS	IN
45	75500	75-78	GMC Suburban C25	34	40
		79-86	GMC Suburban C2500		
		79-86	GMC Suburban C2500		
		73-78	GMC Suburban K15		
		79-86	GMC Suburban K1500		
		79-86	GMC Suburban K1500		
		73-78	GMC Suburban K25		
		79-86	GMC Suburban K2500		
		79-86	GMC Suburban K2500		
		87-91	GMC Suburban R1500		
		87-91	GMC Suburban R2500		
		87-91	GMC Suburban V1500		
		87-91	GMC Suburban V2500		
25	75506	06-08	Ford F-150	36	20
		06-08	Lincoln Mark LT (Built After 8/2005)		
52	75507	04-06	Mazda MPV	44	20
		00-03	Mazda MPV w/Ground Effects		
29	75512	07-12	Mazda CX-7	32	40
10	75515	07-17	Jeep Wrangler Except w/Right Hand Drive, Hard Rock Edition, 75th Anniversary Edition & vehicles with Mopar Off Road Bumper #82213654	15	20
			Jeep Wrangler Right Hand Drive, Except Hard Rock Edition, 75th Anniversary Edition & vehicles with Mopar Off Road Bumper #82213654		
29	75516	03-09	KIA Sorento	37	15
29	75517	07-11	Dodge Nitro	39	20
41	75519	06-08	Mitsubishi Endeavor	34	25
22	75521	99-13	Chevrolet Silverado 1500	42	15
		03-07	Chevrolet Silverado 1500 (Classic)		
		01-03	Chevrolet Silverado 1500 HD		
		05-07	Chevrolet Silverado 1500 HD (Classic)		
		99-04	Chevrolet Silverado 2500		
		99-13	GMC Sierra 1500		
		03-07	GMC Sierra 1500 (Classic)		
		01-03	GMC Sierra 1500 HD		
		05-07	GMC Sierra 1500 HD (Classic)		
		99-04	GMC Sierra 2500		
		37	75522		
25	75527	07-17	Toyota Tundra (See Footnote CP)	32	20
19	75528	08-17	Buick Enclave	24	25
		09-17	Chevrolet Traverse		
		07-16	GMC Acadia		
		07-09	Saturn Outlook		
29	75529	07-09	Suzuki XL-7	26	30
37	75531	07-15	Mazda CX-9	27	15
53	75532	07-12	Hyundai Veracruz	51	30
26	75540	16-17	Lexus RX350 Except F Sport	31	20
		16	Lexus RX450h		
34	75547	07-11	Honda CR-V	33	25
53	75549	07-09	Dodge Sprinter 2500 144" & 170" Wheelbase, Except w/Factory Step Bumper	40	20
		07-09	Dodge Sprinter 3500 144" & 170" Wheelbase, Except w/Factory Step Bumper		
		07-13	Freightliner Sprinter 2500 144" & 170" Wheelbase, Except w/Factory Step Bumper		
		07-13	Freightliner Sprinter 3500 144" & 170" Wheelbase, Except w/Factory Step Bumper		
		07-09	Mercedes-Benz Sprinter 144" & 170" Wheelbase, Except w/Factory Step Bumper		
		10-16	Mercedes-Benz Sprinter 2500 144" & 170" Wheelbase, Except w/Factory Step Bumper		
		10-16	Mercedes-Benz Sprinter 3500 144" & 170" Wheelbase, Except w/Factory Step Bumper		
		10-16	Mercedes-Benz Sprinter 3500 144" & 170" Wheelbase, Except w/Factory Step Bumper		
34	75550	01-10	Chevrolet Silverado 2500 HD	40	20
		03-07	Chevrolet Silverado 2500 HD (Classic)		
		01-02	Chevrolet Silverado 3500		
		03-07	Chevrolet Silverado 3500 (Classic)		
		07-10	Chevrolet Silverado 3500 HD		
		01-10	GMC Sierra 2500 HD		
		03-07	GMC Sierra 2500 HD (Classic)		
		01-02	GMC Sierra 3500		
		03-07	GMC Sierra 3500 (Classic)		
		07-10	GMC Sierra 3500 HD		
		45	75551		
44	75555	07-10	Mitsubishi Outlander	39	25
		11-13	Mitsubishi Outlander Except Outlander Sport		
30	75556	12-15	Chevrolet Captiva Sport	32	15

PC	PART NO.	YEARS	MAKE/MODEL	WGT LBS	IN
30	75556	08-09	Saturn Vue	32	15
44	75560	08-09	Subaru Legacy Sedan	25	25
		05-07	Subaru Legacy Sedan, Except Outback		
		05-07	Subaru Legacy Wagon, Except Outback		
		05-07	Subaru Outback Sedan, Except Sport		
		05-09	Subaru Outback Wagon, Except Sport		
30	75561	05-09	Hyundai Tucson	29	25
		05-10	KIA Sportage 4 Cyl.		
		05-10	KIA Sportage 6 Cyl.		
33	75563	07-09	Acura RDX	27	30
36	75578	08-12	Jeep Liberty	36	20
21	75579	08-16	Chrysler Town & Country	45	20
		08-17	Dodge Grand Caravan		
		12-15	RAM C/V Tradesman		
		09-12	Volkswagen Routan		
35	75586	08-13	Toyota Highlander Except w/Full Size 19" Spare Tire	45	25
31	75599	01-06	Acura MDX Except w/Full Size Spare Tire	40	30
		03-08	Honda Pilot		
51	75600	07-17	BMW X5 Except M Sport Package	41	75
52	75601	07-09	Dodge Sprinter 2500 w/Factory Step Bumper Excluding Models w/30-3/8" Frame Width	50	30
		07-09	Dodge Sprinter 3500 w/Factory Step Bumper Excluding Models w/30-3/8" Frame Width		
		07-13	Freightliner Sprinter 2500 w/Factory Step Bumper Excluding Models w/30-3/8" Frame Width		
		07-13	Freightliner Sprinter 3500 w/Factory Step Bumper Excluding Models w/30-3/8" Frame Width		
		10-16	Mercedes-Benz Sprinter 2500 w/Factory Step Bumper Excluding Models w/30-3/8" Frame Width		
		10-16	Mercedes-Benz Sprinter 3500 w/Factory Step Bumper Excluding Models w/30-3/8" Frame Width		
23	75607	04-12	Chevrolet Colorado	33	25
		04-12	GMC Canyon		
		06	Isuzu I-280		
		07-08	Isuzu I-290		
		07-08	Isuzu I-350		
47	75614	07-13	Acura MDX Except w/Full Size Spare Tire or w/Rear Sport Bumper Option	29	35
35	75644	08-14	Nissan Armada	39	15
30	75647	09-14	Nissan Murano Except w/Aero Kit & CrossCabriolet	28	35
29	75648	09-10	Dodge Journey	28	25
		12-16	Dodge Journey Except w/LED Taillights		
		11-16	Dodge Journey w/LED Taillights		
19	75649	08-16	Toyota Sequoia	21	40
27	75650	09-13	Subaru Forester	36	35
10	75658	09-16	Volkswagen Tiguan	9	20
40	75659	03-04	Honda Element	23	30
		05-11	Honda Element Except SC		
		05-10	Honda Element SC		
11	75662	06-10	Dodge Ram 1500	16	20
		03	Dodge Ram 1500 (Built After 11/2002)		
		04-05	Dodge Ram 1500 Except Daytona/Hemi Sport Quad Cab/Ram Rumble Bee/SRT-10		
		03-09	Dodge Ram 2500		
		03-09	Dodge Ram 3500		
38	75663	09-16	Toyota Venza	39	20
45	75670	10-16	Ford Taurus 4 Dr. Sedan	42	30
33	75671	10-17	Volvo XC60	30	45
30	75673	10-17	Subaru Legacy Sedan	37	45
		10-17	Subaru Outback Wagon, Except Sport		
31	75676	10-15	Lexus RX350 Except F Sport	30	30
		10-15	Lexus RX450h Hybrid		
33	75678	10-13	Ford Transit Connect	30	20
45	75679	09-16	Ford Flex	37	30
		10-16	Lincoln MKT		
28	75682	10-16	Cadillac SRX	22	15
25	75684	10-12	Hyundai Santa Fe	46	15
		11-13	KIA Sorento EX V6, w/Factory Tow Package		
		11-13	KIA Sorento Except SX V6 & EX V6 w/Factory Tow Package		
21	75685	10-17	Lexus GX460	9	15
37	75686	09-10	Ford Edge Sport	29	45

RECEIVER HITCH APPLICATION NUMERICAL

PC	PART NO.	YEARS	MAKE/MODEL	WGT LBS	IN
24	75688	08-14	Land Rover LR2	24	20
33	75690	02-06	Honda CR-V	37	30
20	75691	09-14	Ford F-150	37	20
21	75699	11-13	Jeep Grand Cherokee Except w/OEM Tow Hook	32	20
		14-17	Jeep Grand Cherokee Except w/OEM Tow Hook or ECODiesel Engine		20
		11-13	Jeep Grand Cherokee w/OEM Tow Hook	40	
		14-17	Jeep Grand Cherokee w/OEM Tow Hook, Except w/ECODiesel Engine	40	
19	75703	75-83	Ford E-100 Econoline	33	20
		75-14	Ford E-150 Econoline	20	
		75-14	Ford E-250 Econoline	20	
		75-02	Ford E-350 Econoline	20	
		03-14	Ford E-350 Econoline Super Duty	20	
43	75707	11-14	Chevrolet Silverado 2500 HD	51	20
		11-14	Chevrolet Silverado 3500 HD	20	
		11-14	GMC Sierra 2500 HD	20	
		11-14	GMC Sierra 3500 HD	20	
20	75710†	11-17	Ford Explorer	30	45
23	75712	07-17	Jeep Compass	29	15
		07-17	Jeep Compass	30	
		07-10	Jeep Compass Rallye Edition	30	
		07-17	Jeep Patriot	15	
		07-17	Jeep Patriot	30	
25	75713	11-17	Dodge Durango	31	20
		14-17	Jeep Grand Cherokee EcoDiesel	20	
51	75714	11-16	Nissan Quest	46	35
28	75715	12-16	Nissan NV1500	42	20
		12-16	Nissan NV2500	20	
		12-16	Nissan NV3500	20	
36	75716	11-14	Subaru Tribeca	35	30
23	75717	10-15	Hyundai Tucson	32	20
		11-16	KIA Sportage	20	
29	75725	02	Cadillac Escalade	39	15
		02	Cadillac Escalade EXT	15	
		02-06	Chevrolet Avalanche 1500	15	
		02-06	Chevrolet Avalanche 2500	15	
		00-06	Chevrolet Suburban 1500 w/Amber Turn Signals	15	
		00-06	Chevrolet Suburban 2500 w/Amber Turn Signals	15	
		00-06	Chevrolet Tahoe w/Amber Turn Signals	15	
		01-02	GMC Yukon Denali w/Amber Turn Signals	15	
		00-06	GMC Yukon w/Amber Turn Signals	15	
		00-06	GMC Yukon XL 1500	15	
		01-02	GMC Yukon XL 1500 Denali	15	
		00-06	GMC Yukon XL 2500	15	
45	75726	08-13	Toyota Highlander	48	40
38	75728	11-14	Ford Edge Sport	34	45
53	75730	08-14	Toyota Hilux	44	60
27	75740	97-03	Ford F-150 Flareside	37	20
		04	Ford F-150 Heritage Flareside	20	
		04	Ford F-150 Heritage Styleside	20	
		97-03	Ford F-150 Styleside	20	
		00-03	Ford F-150 SuperCrew	20	
		97-99	Ford F-250 Styleside	20	
		99-07	Ford F-250 Super Duty Except Cab & Chassis	20	
		99-07	Ford F-350 Super Duty Except Cab & Chassis	20	
38	75741	04-10	Infiniti QX56	35	15
		05-07	Nissan Armada	15	
		04	Nissan Pathfinder Armada	15	
16	75742	12-16	Honda CR-V	28	40
35	75748†	13-15	Mazda CX-5	39	40
34	75751	05-12	Ford Escape	35	25
		05-11	Mazda Tribute	25	
		05-11	Mercury Mariner	25	
40	75758	13-17	Ford Escape	41	15
33	75761	13-15	BMW X1 w/Panoramic Moonroof	31	60
36	75768	11-17	BMW X3	27	90
31	75772	13-17	Hyundai Santa Fe Sport (5 Passenger)	37	30
		14-15	KIA Sorento Except LX I4	30	
		14-15	KIA Sorento LX I4	30	
56	75774	10-15	Mercedes-Benz GLK350	37	20
33	75776	13-17	Hyundai Santa Fe (6/7 Passenger)	32	30
38	75778	09-12	Infiniti FX35	40	40
		13	Infiniti FX37	40	
		09-13	Infiniti FX50	40	
		14-16	Infiniti QX70	40	
43	75782	13-17	Ford Escape	36	20

PC	PART NO.	YEARS	MAKE/MODEL	WGT LBS	IN
19	75784	10-17	Acura RDX	28	30
54	75790	13-16	Ford Ranger	25	30
38	75791	16	Toyota Hilux	46	45
51	75792	13	Isuzu D-Max	33	20
59	75808	13	Volkswagen Amarok (International Only)	36	30
53	75810	13	Chevrolet S10	42	30
28	75836	16-17	Hyundai Tucson	28	30
35	75838	14-15	Jeep Cherokee Trailhawk	38	30
32	75852	14-16	Ford Transit Connect	34	15
33	75866	14-17	Chevrolet Silverado 1500	47	20
		14-17	GMC Sierra 1500	20	
54	75874†	12-15	Mercedes-Benz ML350 Except BlueTEC & w/Active Curve System	24	30
29	75876	14-17	Subaru Forester	35	25
58	75882	14-16	RAM ProMaster 1500 Except w/Extended Body	51	45
		14-16	RAM ProMaster 2500 Except w/Extended Body	45	
		14-16	RAM ProMaster 3500 Except w/Extended Body	45	
36	75888	14-17	Mitsubishi Outlander Except Outlander Sport	42	30
40	75894	15-16	KIA Sedona	45	20
39	75896	14-16	Toyota Highlander	45	30
31	75898	15-16	Chevrolet City Express	35	30
		13-16	Nissan NV200	30	
25	75902	14-16	Nissan Rogue	32	15
		08-13	Nissan Rogue Except Krom	15	
		14	Nissan Rogue Select	15	
38	75904	14	Toyota Prado	37	15
42	75906	15-16	Chevrolet Silverado 2500 HD	54	30
		15-16	Chevrolet Silverado 3500 HD	30	
		15-16	GMC Sierra 2500 HD	30	
		15-16	GMC Sierra 3500 HD	30	
36	75908	16-17	KIA Sorento	38	40
51	75910	15-17	Ford F-150	42	30
27	75912	15-17	Ford Transit-150 Except Cab & Chassis and the Cutaway	30	25
		15-17	Ford Transit-250 Except Cab & Chassis and the Cutaway	25	
		15-17	Ford Transit-350 Except Cab & Chassis and the Cutaway	25	
38	75914	14	Toyota Hilux SW4	38	15
27	75916	11-17	Volvo S60 Sedan	32	70
		15-16	Volvo V60 (App. starts with 2015-1/2)	70	
		08-10	Volvo V70 Wagon	70	
		08-16	Volvo XC70 Wagon, AWD	70	
27	75938	15-17	Ford F-150	36	30
37	75940	11-17	Audi Q5	43	60
		15-17	Porsche Macan	60	
34	75943	15-17	Lincoln MKC	43	45
34	75948	15-16	Chevrolet Colorado	35	35
		15-16	GMC Canyon	35	
45	75950	07-16	Audi Q7	51	70
		11-16	Porsche Cayenne	70	
		11-17	Volkswagen Touareg	70	
28	75952	15-16	Nissan Murano	34	15
29	75956	15-17	Lexus NX200t	37	35
20	75992	07-14	Ford Edge Except Sport	30	55
		07-15	Lincoln MKX	55	
30	75998	14-17	Jeep Cherokee	39	60
30	76004	15-16	Chevrolet Colorado	46	35
		15-16	GMC Canyon	35	
34	76014	16-17	Volvo XC90	39	90
32	76015	16	Mercedes-Benz Metris	41	20
31	76016	14-17	Chevrolet Silverado 1500	46	25
		14-17	GMC Sierra 1500	25	
25	76018	16-17	BMW X1	37	40
26	76019	16	FIAT 500X	36	30
24	76020	16	Mazda CX-9	38	30
26	76021	15-16	Jeep Renegade	37	40
23	76022	17	Cadillac XT5 Except Platinum	34	20
24	76023	17	GMC Acadia	32	90
52	76024	16-17	Mercedes-Benz GLE350 Except w/Active Curve System	43	40
		12-15	Mercedes-Benz ML350 Except w/Active Curve System	40	
32	76025	11-16	Honda Odyssey	42	80
15	76028	05-17	Chevrolet Equinox	33	30
		10-17	GMC Terrain	30	
		06-09	Pontiac Torrent	30	
		02-07	Saturn Vue Except Redline	30	
21	76031	13	Infiniti JX35	35	25
		14-17	Infiniti QX60	25	
		13-17	Nissan Pathfinder	25	
20	76034	11-17	Ford Explorer	29	45
28	76046	17	Chrysler Pacifica Except LX & Touring	44	45

RECEIVER HITCH APPLICATION NUMERICAL

PC	PART NO.	YEARS	MAKE/MODEL	WGT LBS	IN
28	76046	17	Chrysler Pacifica Except Touring L, Touring L Plus & Limited	44	45
25	76050	14-16	RAM ProMaster 1500 All Models	32	45
		14-16	RAM ProMaster 2500 All Models	45	45
		14-16	RAM ProMaster 3500 All Models	45	45
29	76074	17	KIA Sportage Except SX & SX Turbo	36	25
34	76076	17	Audi Q7	40	60
38	76078	16	Nissan NP300 Navara	40	30
24	76080	16-17	Buick Envision	28	45
27	76082	16	Mercedes-Benz GLC300	37	65
24	76084	15-16	Subaru Crosstrek	36	20
		15-16	Subaru Crosstrek Except Hybrid	20	20
		13-15	Subaru XV Crosstrek Except Hybrid	20	20
25	76098	11-16	Mitsubishi Outlander Sport	34	20
		11-16	Mitsubishi RVR (Canada Only)	30	30
11	76104	07-17	Jeep Wrangler	16	20
32	76112	11-14	Toyota Sienna	32	60
		15-17	Toyota Sienna Except SE	60	60
		15-17	Toyota Sienna SE	60	60
CLASS III/IV: MULTI-FIT					
54	37130	88-99	Chevrolet C1500	62	40
		92-00	Chevrolet C2500 Crew Cab	40	40
		88-99	Chevrolet C2500 Regular & Extended Cabs	40	40
		92-00	Chevrolet C3500 Crew Cab	40	40
		88-00	Chevrolet C3500 Regular & Extended Cabs	40	40
		88-99	Chevrolet K1500	40	40
		92-00	Chevrolet K2500 Crew Cab	40	40
		88-99	Chevrolet K2500 Regular & Extended Cabs	40	40
		92-00	Chevrolet K3500 Crew Cab	40	40
		88-00	Chevrolet K3500 Regular & Extended Cabs	40	40
		99-02	Chevrolet Silverado 1500	25	25
		03-07	Chevrolet Silverado 1500 (Classic)	25	25
		01-03	Chevrolet Silverado 1500 HD	25	25
		05-07	Chevrolet Silverado 1500 HD (Classic)	25	25
		99-04	Chevrolet Silverado 2500	25	25
		71-89	Dodge D100	25	25
		77-93	Dodge D150	25	25
		71-80	Dodge D200	25	25
		81-93	Dodge D250	25	25
		71-80	Dodge D300	25	25
		86-93	Dodge D350	25	25
		94-01	Dodge Ram 1500	40	40
		94-02	Dodge Ram 2500	40	40
		94-02	Dodge Ram 3500	40	40
		71-89	Dodge W100	25	25
		77-93	Dodge W150	25	25
		71-80	Dodge W200	25	25
		81-85	Dodge W250	25	25
		71-80	Dodge W300	25	25
		81-93	Dodge W350	25	25
		75-79	Ford F-100	35	35
		80-83	Ford F-100 Except w/Custom Fascia	35	35
		75-96	Ford F-150	35	35
		80-86	Ford F-150 Except w/Custom Fascia	35	35
		97-03	Ford F-150 Flareside	25	25
		04	Ford F-150 Heritage Flareside	25	25
		04	Ford F-150 Heritage Styleside	25	25
		97-03	Ford F-150 Styleside	25	25
		00-03	Ford F-150 SuperCrew	25	25
		75-96	Ford F-250	35	35
		80-86	Ford F-250 Except w/Custom Fascia	35	35
		97	Ford F-250 Heavy Duty	35	35
		97-99	Ford F-250 Styleside	25	25
		99-04	Ford F-250 Super Duty Except Cab & Chassis	30	30
		75-96	Ford F-350	35	35
		80-86	Ford F-350 Except w/Custom Fascia	35	35
		97	Ford F-350 Heavy Duty	35	35
		99-04	Ford F-350 Super Duty Except Cab & Chassis	30	30
		88-99	GMC C1500	40	40
		88-00	GMC C2500	40	40
		88-00	GMC C3500	40	40
88-99	GMC K1500	40	40		
88-00	GMC K2500	40	40		
88-00	GMC K3500	40	40		
99-02	GMC Sierra 1500	25	25		
03-07	GMC Sierra 1500 (Classic)	25	25		
01-03	GMC Sierra 1500 HD	25	25		
05-07	GMC Sierra 1500 HD (Classic)	25	25		

PC	PART NO.	YEARS	MAKE/MODEL	WGT LBS	IN
54	37130	99-04	GMC Sierra 2500	62	25
		00-06	Toyota Tundra	30	30
49	37133	88-99	Chevrolet C1500	57	40
		92-00	Chevrolet C2500 Crew Cab	40	40
		88-99	Chevrolet C2500 Regular & Extended Cabs	40	40
		92-00	Chevrolet C3500 Crew Cab	40	40
		88-00	Chevrolet C3500 Regular & Extended Cabs	40	40
		88-99	Chevrolet K1500	40	40
		92-00	Chevrolet K2500 Crew Cab	40	40
		88-99	Chevrolet K2500 Regular & Extended Cabs	40	40
		92-00	Chevrolet K3500 Crew Cab	40	40
		88-00	Chevrolet K3500 Regular & Extended Cabs	40	40
		99-02	Chevrolet Silverado 1500	25	25
		03-07	Chevrolet Silverado 1500 (Classic)	25	25
		01-03	Chevrolet Silverado 1500 HD	25	25
		05-07	Chevrolet Silverado 1500 HD (Classic)	25	25
		99-04	Chevrolet Silverado 2500	25	25
		71-89	Dodge D100	25	25
		77-93	Dodge D150	25	25
		71-80	Dodge D200	25	25
		81-93	Dodge D250	25	25
		71-80	Dodge D300	25	25
		81-93	Dodge D350	25	25
		94-01	Dodge Ram 1500	40	40
		94-02	Dodge Ram 2500	40	40
		94-02	Dodge Ram 3500	40	40
		71-89	Dodge W100	25	25
		77-93	Dodge W150	25	25
		71-80	Dodge W200	25	25
		81-93	Dodge W250	25	25
		71-80	Dodge W300	25	25
		81-93	Dodge W350	25	25
		75-79	Ford F-100	35	35
		80-83	Ford F-100 Except w/Custom Fascia	35	35
		75-05	Ford F-150	35	35
		75-05	Ford F-150	45	45
		80-86	Ford F-150 Except w/Custom Fascia	35	35
		97-03	Ford F-150 Flareside	25	25
		04	Ford F-150 Heritage Flareside	25	25
		04	Ford F-150 Heritage Styleside	25	25
		97-03	Ford F-150 Styleside	25	25
		00-03	Ford F-150 SuperCrew	25	25
		75-96	Ford F-250	35	35
		80-86	Ford F-250 Except w/Custom Fascia	35	35
		97	Ford F-250 Heavy Duty	35	35
97-99	Ford F-250 Styleside	25	25		
99-04	Ford F-250 Super Duty Except Cab & Chassis	30	30		
75-96	Ford F-350	35	35		
80-86	Ford F-350 Except w/Custom Fascia	35	35		
97	Ford F-350 Heavy Duty	35	35		
99-04	Ford F-350 Super Duty Except Cab & Chassis	30	30		
88-99	GMC C1500	40	40		
88-00	GMC C2500	40	40		
88-99	GMC C3500	40	40		
88-00	GMC K1500	40	40		
88-00	GMC K2500	40	40		
88-00	GMC K3500	40	40		
99-02	GMC Sierra 1500	25	25		
03-07	GMC Sierra 1500 (Classic)	25	25		
01-03	GMC Sierra 1500 HD	25	25		
05-07	GMC Sierra 1500 HD (Classic)	25	25		
99-04	GMC Sierra 2500	25	25		
00-06	Toyota Tundra	35	35		
50	37136	90-05	Chevrolet Astro Extended Body	60	65
		92-94	Chevrolet Blazer Full Size	30	30
		96-14	Chevrolet Express 1500	30	30
		96-16	Chevrolet Express 2500	30	30
		96-16	Chevrolet Express 3500	30	30
		98-04	Chevrolet S10	30	30
		83-97	Chevrolet S10 w/Standard Bed & Step Bumper	30	30
		00-06	Chevrolet Suburban 1500 w/Amber Turn Signals	30	30
		00-06	Chevrolet Suburban 2500 w/Amber Turn Signals	30	30
		92-99	Chevrolet Suburban C1500	30	30
		92-99	Chevrolet Suburban C2500	30	30
		92-99	Chevrolet Suburban K1500	30	30
		92-99	Chevrolet Suburban K2500	30	30
		95-00	Chevrolet Tahoe	30	30

RECEIVER HITCH APPLICATION NUMERICAL

RECEIVER HITCH APPLICATION NUMERICAL

PC	PART NO.	YEARS	MAKE/MODEL	WGT					
				LBS	IN				
50	37136	00-06	Chevrolet Tahoe w/Amber Turn Signals	60	30				
		96-03	Chrysler Town & Country						
		90-95	Chrysler Town & Country 2 WD Long Wheelbase						
		04-07	Chrysler Town & Country Except w/Stow & Go Seats						
		01-03	Chrysler Voyager						
		96-03	Dodge Caravan						
		91-95	Dodge Caravan C/V Short Wheelbase, 2 WD						
		04-07	Dodge Caravan Except w/Stow & Go Seats						
		84-95	Dodge Caravan Short Wheelbase, 2 WD						
		87-01	Dodge Dakota						
		02-04	Dodge Dakota Except Quad Cab						
		96-03	Dodge Grand Caravan						
		04-07	Dodge Grand Caravan Except w/Stow & Go Seats						
		87-93	Dodge Grand Caravan Long Wheelbase, 2 WD						
		94-95	Dodge Grand Caravan Long Wheelbase, 2 WD, Except LE						
		82-93	Dodge Ramcharger						
		86-97	Ford Aerostar Extended Body						
		82-96	Ford Bronco						
		84-90	Ford Bronco II						
		01-04	Ford Escape						
		98-11	Ford Ranger Except Flareside or w/Rear Fascia						
		83-97	Ford Ranger Except w/Rear Fascia						
		03	Ford Windstar (Built After 11/2002)						
		99-03	Ford Windstar (Built Before 11/2002)						
		83-90	GMC S15 w/Standard Bed & Step Bumper						
		90-05	GMC Safari Extended Body						
		96-14	GMC Savana 1500						
		96-16	GMC Savana 2500						
		96-16	GMC Savana 3500						
		98-04	GMC Sonoma						
		92-99	GMC Suburban C1500						
		92-99	GMC Suburban C2500						
		92-99	GMC Suburban K1500						
		92-99	GMC Suburban K2500						
		92-00	GMC Yukon						
		99-00	GMC Yukon Denali						
		01-02	GMC Yukon Denali w/Amber Turn Signals						
		00-06	GMC Yukon w/Amber Turn Signals						
		00-06	GMC Yukon XL 1500						
		01-02	GMC Yukon XL 1500 Denali						
		00-06	GMC Yukon XL 2500						
		98-00	Isuzu Hombre w/Step Bumper						
		84-01	Jeep Cherokee						
		84-01	Jeep Cherokee						
		93-98	Jeep Grand Cherokee						
		02-07	Jeep Liberty						
		90-93	Mazda B2200						
		94-09	Mazda B2300						
		98-01	Mazda B2500						
		90-93	Mazda B2600						
		94-08	Mazda B3000						
		94-09	Mazda B4000						
		01-04	Mazda Tribute						
		88-94	Nissan D21						
		86-87	Nissan D21 (App. starts with 86-1/2)						
		98-04	Nissan Frontier						
		95-97	Nissan Pickup						
		87-00	Plymouth Grand Voyager						
		87-00	Plymouth Grand Voyager						
		91-95	Plymouth Grand Voyager Long Wheelbase, 2 WD						
		84-00	Plymouth Voyager						
		84-00	Plymouth Voyager						
		30	40050			63-86	Chevrolet C10	57	40
						88-99	Chevrolet C1500		
						63-86	Chevrolet C20		
						92-00	Chevrolet C2500 Crew Cab		
						88-99	Chevrolet C2500 Regular & Extended Cabs		
						63-86	Chevrolet C30		
						88-00	Chevrolet C3500 Regular & Extended Cabs		
						68-89	Dodge D100		
						77-93	Dodge D150		
						68-80	Dodge D200		
						81-93	Dodge D250		
						68-80	Dodge D300		
						81-93	Dodge D350		
						94-01	Dodge Ram 1500		
						94-02	Dodge Ram 2500		

PC	PART NO.	YEARS	MAKE/MODEL	WGT					
				LBS	IN				
30	40050	94-02	Dodge Ram 3500	57	40				
		74-88	Dodge Ramcharger Except w/Skid Shield						
		67-77	Dodge W100						
		77-93	Dodge W150						
		67-80	Dodge W200						
		81-93	Dodge W250						
		67-80	Dodge W300						
		81-93	Dodge W350						
		78-96	Ford Bronco						
		89-97	Ford F Super Duty Cab & Chassis, w/34" Wide Frames & 161" Wheelbase						
		63-79	Ford F-100						
		80-83	Ford F-100 Except w/Custom Fascia						
		75-96	Ford F-150						
		80-86	Ford F-150 Except w/Custom Fascia						
		63-96	Ford F-250						
		80-86	Ford F-250 Except w/Custom Fascia						
		97	Ford F-250 Heavy Duty						
		63-96	Ford F-350						
		80-86	Ford F-350 Except w/Custom Fascia						
		97	Ford F-350 Heavy Duty						
		99-00	Ford F-350 Super Duty Cab & Chassis, w/34" Wide Frames						
		63-65	GMC 1000 Series						
		63-65	GMC 1500 Series						
		63-65	GMC 2500 Series						
		63-66	GMC 3000						
		63-66	GMC 3500						
		75-78	GMC C15						
		67-74	GMC C15/C1500						
		79-99	GMC C1500						
		67-78	GMC C25						
		79-00	GMC C2500						
		67-78	GMC C35						
		79-00	GMC C3500						
		74-81	Plymouth Trailduster Except w/Skid Shield						
		CLASS V: 2" RECEIVER							
		45	41901			88-99	Chevrolet C1500	73	30
						92-00	Chevrolet C2500 Crew Cab		
						88-99	Chevrolet C2500 Regular & Extended Cabs		
						92-00	Chevrolet C3500 Crew Cab		
						88-00	Chevrolet C3500 Regular & Extended Cabs		
						88-99	Chevrolet K1500		
						92-00	Chevrolet K2500 Crew Cab		
						88-99	Chevrolet K2500 Regular & Extended Cabs		
						92-00	Chevrolet K3500 Crew Cab		
						88-00	Chevrolet K3500 Regular & Extended Cabs		
						88-99	GMC C1500		
						88-00	GMC C2500		
88-00	GMC C3500								
88-99	GMC K1500								
88-00	GMC K2500								
88-00	GMC K3500								
45	41902			68-89	Dodge D100	72	40		
		77-93	Dodge D150						
		68-80	Dodge D200						
		81-93	Dodge D250						
		71-80	Dodge D300						
		81-93	Dodge D350						
		67-89	Dodge W100						
		77-93	Dodge W150						
		67-80	Dodge W200						
		81-93	Dodge W250						
		67-80	Dodge W300						
81-93	Dodge W350								
45	41904	80-83	Ford F-100 Except w/Custom Fascia	75	30				
		87-96	Ford F-150						
		80-86	Ford F-150 Except w/Custom Fascia						
		87-96	Ford F-250						
		80-86	Ford F-250 Except w/Custom Fascia						
		97	Ford F-250 Heavy Duty						
		87-96	Ford F-350						
		80-86	Ford F-350 Except w/Custom Fascia						
		97	Ford F-350 Heavy Duty						
		80-86	Ford F-350 Heavy Duty						
37	41906	92-14	Ford E-150 Econoline	56	30				
		92-14	Ford E-250 Econoline						
		92-02	Ford E-350 Econoline						
		03-14	Ford E-350 Econoline Super Duty						
		03-14	Ford E-350 Econoline Super Duty						

RECEIVER HITCH APPLICATION NUMERICAL

PC	PART NO.	YEARS	MAKE/MODEL	WGT LBS	IN				
63	41910	78-80	Dodge Van, B100	68	35				
		81-94	Dodge Van, B150						
		95-98	Dodge Van, B1500						
		78-80	Dodge Van, B200						
		81-94	Dodge Van, B250						
		95-98	Dodge Van, B2500						
		78-80	Dodge Van, B300						
		81-94	Dodge Van, B350						
		95-98	Dodge Van, B3500						
		99-00	Dodge Van, Ram 1500						
		01-03	Dodge Van, Ram 1500 Except w/109.3" Wheelbase						
		99-00	Dodge Van, Ram 2500						
		01-03	Dodge Van, Ram 2500 Except w/109.3" Wheelbase						
		99-00	Dodge Van, Ram 3500						
		01-03	Dodge Van, Ram 3500 Except w/109.3" Wheelbase						
		48	41920			97-03	Ford F-150 Flareside	70	30
						04	Ford F-150 Heritage Flareside		
04	Ford F-150 Heritage Styleside								
97-03	Ford F-150 Styleside								
00-03	Ford F-150 SuperCrew								
97-99	Ford F-250 Styleside								
97-99	Ford F-250 Styleside								
51	41922	99-04	Ford F-250 Super Duty Except Cab & Chassis	58	15				
		99-04	Ford F-350 Super Duty Except Cab & Chassis						
45	41923	94-01	Dodge Ram 1500	69	35				
		94-02	Dodge Ram 2500						
		94-02	Dodge Ram 3500						
35	41926	00-14	Ford E-150 Econoline	51	30				
		00-14	Ford E-250 Econoline						
		00-02	Ford E-350 Econoline						
		03-14	Ford E-350 Econoline Super Duty						
37	41929	06-08	Dodge Ram 1500	70	35				
		03	Dodge Ram 1500 (Built After 11/2002)						
		04-05	Dodge Ram 1500 Except Daytona/Hemi Sport Quad Cab/Ram Rumble Bee/SRT-10						
		03-10	Dodge Ram 2500						
		03-10	Dodge Ram 3500						
		11-17	RAM 2500						
		11-17	RAM 3500						
30	41930	00-06	Chevrolet Suburban 1500 w/Amber Turn Signals	59	35				
		00-06	Chevrolet Suburban 2500 w/Amber Turn Signals						
		00-06	GMC Yukon XL 1500						
		01-02	GMC Yukon XL 1500 Denali						
		00-06	GMC Yukon XL 2500						
55	41931	99-16	Ford F-250 Super Duty Except Cab & Chassis	73	30				
		99-16	Ford F-350 Super Duty Except Cab & Chassis						
50	41932	99-02	Chevrolet Silverado 1500	73	20				
		03-07	Chevrolet Silverado 1500 (Classic)						
		01-03	Chevrolet Silverado 1500 HD						
		05-07	Chevrolet Silverado 1500 HD (Classic)						
		99-04	Chevrolet Silverado 2500						
		99-02	GMC Sierra 1500						
		03-07	GMC Sierra 1500 (Classic)						
		01-03	GMC Sierra 1500 HD						
		05-07	GMC Sierra 1500 HD (Classic)						
		99-04	GMC Sierra 2500						
37	41933	06-08	Ford F-150	67	20				
		06-08	Lincoln Mark LT (Built After 8/2005)						
70	41935	07-17	Toyota Tundra (See Footnote CP)	84	30				
29	41936	01-07	Chevrolet Silverado 3500 Cab & Chassis, w/34" Wide Frames (Classic)	55	30				
		07-16	Chevrolet Silverado 3500 HD Cab & Chassis, w/34" Wide Frames						
		07-10	Dodge Ram 3500 Cab & Chassis, w/34" Wide Frames						
		08-10	Dodge Ram 4500 Cab & Chassis, w/34" Wide Frames						
		08-10	Dodge Ram 5500 Cab & Chassis, w/34" Wide Frames						
		01-07	GMC Sierra 3500 Cab & Chassis, w/34" Wide Frames (Classic)						
		07-16	GMC Sierra 3500 HD Cab & Chassis, w/34" Wide Frames						
		11-12	RAM 3500 Cab & Chassis, w/34" Wide Frames						
		11-12	RAM 4500 Cab & Chassis, w/34" Wide Frames						
		11-12	RAM 5500 Cab & Chassis, w/34" Wide Frames						
		08-09	Sterling Truck Bullet 45 w/34" Wide Frames						
		08-09	Sterling Truck Bullet 55 w/34" Wide Frames						
		50	41938			63-84	Chevrolet C10	73	40
						85-86	Chevrolet C10 w/34" Wide Frames		
63-84	Chevrolet C20								
85-86	Chevrolet C20 w/34" Wide Frames								
88-91	Chevrolet C2500 Crew Cab								
63-84	Chevrolet C30								

PC	PART NO.	YEARS	MAKE/MODEL	WGT LBS	IN
50	41938	85-86	Chevrolet C30 w/34" Wide Frames	73	40
		88-91	Chevrolet C3500 Crew Cab		
		63-84	Chevrolet K10		
		85-86	Chevrolet K10 w/34" Wide Frames		
		63-84	Chevrolet K20		
		85-86	Chevrolet K20 w/34" Wide Frames		
		88-91	Chevrolet K2500 Crew Cab		
		73-84	Chevrolet K30		
		85-86	Chevrolet K30 w/34" Wide Frames		
		88-91	Chevrolet K3500 Crew Cab		
		01-07	Chevrolet Silverado 3500 Cab & Chassis, w/34" Wide Frames (Classic)		
		07-16	Chevrolet Silverado 3500 HD Cab & Chassis, w/34" Wide Frames		
		99-00	Ford F-350 Super Duty Cab & Chassis, w/34" Wide Frames		
		63-65	GMC 1000 Series		
		63-65	GMC 1500 Series		
		63-65	GMC 2500 Series		
		63-66	GMC 3000		
		63-66	GMC 3500		
		75-78	GMC C15		
		67-74	GMC C15/C1500		
		79-84	GMC C1500		
		85-99	GMC C1500 w/34" Wide Frames		
		67-78	GMC C25		
		79-84	GMC C2500		
		85-00	GMC C2500 w/34" Wide Frames		
		67-78	GMC C35		
		79-84	GMC C3500		
		85-00	GMC C3500 w/34" Wide Frames		
		67-78	GMC K15		
		79-84	GMC K1500		
		85-99	GMC K1500 w/34" Wide Frames		
		67-78	GMC K25		
		79-84	GMC K2500		
85-00	GMC K2500 w/34" Wide Frames				
68-78	GMC K35				
79-84	GMC K3500				
85-00	GMC K3500 w/34" Wide Frames				
01-07	GMC Sierra 3500 Cab & Chassis, w/34" Wide Frames (Classic)				
07-16	GMC Sierra 3500 HD Cab & Chassis, w/34" Wide Frames				
50	41942	11-14	Chevrolet Silverado 2500 HD	67	20
		11-14	Chevrolet Silverado 3500 HD		
		11-14	GMC Sierra 2500 HD		
		11-14	GMC Sierra 3500 HD		
70	41943	99-16	Ford F-350 Super Duty Cab & Chassis, w/34" Wide Frames	90	40
		99-16	Ford F-450 Super Duty Cab & Chassis, w/34" Wide Frames		
		99-16	Ford F-550 Super Duty Cab & Chassis, w/34" Wide Frames		
35	41944	01-10	Chevrolet Silverado 2500 HD	68	25
		03-07	Chevrolet Silverado 2500 HD (Classic)		
		01-02	Chevrolet Silverado 3500		
		03-07	Chevrolet Silverado 3500 (Classic)		
		07-10	Chevrolet Silverado 3500 HD		
		01-10	GMC Sierra 2500 HD		
		03-07	GMC Sierra 2500 HD (Classic)		
		01-02	GMC Sierra 3500		
		03-07	GMC Sierra 3500 (Classic)		
		07-10	GMC Sierra 3500 HD		
41	41945	00-14	Ford E-150 Econoline	44	30
		00-14	Ford E-250 Econoline		
		00-02	Ford E-350 Econoline		
		03-14	Ford E-350 Econoline Super Duty		
42	41946	96-14	Chevrolet Express 1500	54	35
		96-17	Chevrolet Express 2500		
		96-17	Chevrolet Express 3500		
		96-14	GMC Savana 1500		
		96-17	GMC Savana 2500		
50	41947	96-17	GMC Savana 3500	80	35
		63-84	Chevrolet C10		
		85-86	Chevrolet C10 w/34" Wide Frames		
		63-84	Chevrolet C20		
		85-86	Chevrolet C20 w/34" Wide Frames		
		88-91	Chevrolet C2500 Crew Cab		
		63-84	Chevrolet C30		
		85-86	Chevrolet C30 w/34" Wide Frames		
88-91	Chevrolet C3500 Crew Cab				
63-84	Chevrolet K10				
85-86	Chevrolet K10 w/34" Wide Frames				

RECEIVER HITCH APPLICATION NUMERICAL

RECEIVER HITCH APPLICATION NUMERICAL

PC	PART NO.	YEARS	MAKE/MODEL	WGT LBS	IN				
50	41947	63-84	Chevrolet K20	80	35				
		85-86	Chevrolet K20 w/34" Wide Frames						
		88-91	Chevrolet K2500 Crew Cab						
		73-84	Chevrolet K30						
		85-86	Chevrolet K30 w/34" Wide Frames						
		88-91	Chevrolet K3500 Crew Cab						
		03-09	Chevrolet Kodiak C4500 Cab & Chassis, w/34" Wide Frames						
		03-09	Chevrolet Kodiak C5500 Cab & Chassis, w/34" Wide Frames						
		99-09	Chevrolet Kodiak C6500 Cab & Chassis, w/34" Wide Frames						
		99-09	Chevrolet Kodiak C7500 Cab & Chassis, w/34" Wide Frames						
		99-09	Chevrolet Kodiak C8500 Cab & Chassis, w/34" Wide Frames						
		01-07	Chevrolet Silverado 3500 Cab & Chassis, w/34" Wide Frames (Classic)						
		07-16	Chevrolet Silverado 3500 HD Cab & Chassis, w/34" Wide Frames						
		07-10	Dodge Ram 3500 Cab & Chassis, w/34" Wide Frames						
		08-10	Dodge Ram 4500 Cab & Chassis, w/34" Wide Frames						
		08-10	Dodge Ram 5500 Cab & Chassis, w/34" Wide Frames						
		99-16	Ford F-350 Super Duty Cab & Chassis, w/34" Wide Frames						
		99-16	Ford F-450 Super Duty Cab & Chassis, w/34" Wide Frames						
		99-16	Ford F-550 Super Duty Cab & Chassis, w/34" Wide Frames						
		63-65	GMC 1000 Series						
		63-65	GMC 1500 Series						
		63-65	GMC 2500 Series						
		63-66	GMC 3000						
		63-66	GMC 3500						
		75-78	GMC C15						
		67-74	GMC C15/C1500						
		79-84	GMC C1500						
		85-99	GMC C1500 w/34" Wide Frames						
		67-78	GMC C25						
		79-84	GMC C2500						
		85-00	GMC C2500 w/34" Wide Frames						
		67-78	GMC C35						
		79-84	GMC C3500						
		85-00	GMC C3500 w/34" Wide Frames						
		03-09	GMC C4500 Topkick Cab & Chassis, w/34" Wide Frames						
		03-09	GMC C5500 Topkick Cab & Chassis, w/34" Wide Frames						
		99-09	GMC C6500 Topkick Cab & Chassis, w/34" Wide Frames						
		99-09	GMC C7500 Topkick Cab & Chassis, w/34" Wide Frames						
		67-78	GMC K15						
		79-84	GMC K1500						
		85-99	GMC K1500 w/34" Wide Frames						
		67-78	GMC K25						
		79-84	GMC K2500						
		85-00	GMC K2500 w/34" Wide Frames						
		68-78	GMC K35						
		79-84	GMC K3500						
		85-00	GMC K3500 w/34" Wide Frames						
		01-07	GMC Sierra 3500 Cab & Chassis, w/34" Wide Frames (Classic)						
		07-16	GMC Sierra 3500 HD Cab & Chassis, w/34" Wide Frames						
		11-12	RAM 3500 Cab & Chassis, w/34" Wide Frames						
		11-12	RAM 4500 Cab & Chassis, w/34" Wide Frames						
		11-12	RAM 5500 Cab & Chassis, w/34" Wide Frames						
		08-09	Sterling Truck Bullet 45 w/34" Wide Frames						
		08-09	Sterling Truck Bullet 55 w/34" Wide Frames						
		39	41948			11-17	RAM 1500	56	30
		48	41950			15-16	Chevrolet Silverado 2500 HD	72	60
						15-16	Chevrolet Silverado 3500 HD		
						15-16	GMC Sierra 2500 HD		
						15-16	GMC Sierra 3500 HD		
		38	41952			13-16	RAM 4500 Cab & Chassis, w/34" Wide Frames	59	45
13-16	RAM 5500 Cab & Chassis, w/34" Wide Frames								
CLASS V: 2-1/2" RECEIVER									
54	45502	87-96	Ford F-250	64	45				
		80-86	Ford F-250 Except w/Custom Fascia						
		97	Ford F-250 Heavy Duty						
		87-96	Ford F-350						
		80-86	Ford F-350 Except w/Custom Fascia						
		97	Ford F-350 Heavy Duty						
50	45505	71-80	Dodge D200	68	45				
		81-93	Dodge D250						
		71-80	Dodge D300						
		86-93	Dodge D350						
		94-98	Dodge Ram 2500						
		94-98	Dodge Ram 3500						
		71-80	Dodge W200						
		81-93	Dodge W250						

PC	PART NO.	YEARS	MAKE/MODEL	WGT LBS	IN
50	45505	71-80	Dodge W300	68	45
		81-93	Dodge W350		
59	45506	92-00	Chevrolet C2500 Crew Cab	66	45
		88-99	Chevrolet C2500 Regular & Extended Cabs		
		92-00	Chevrolet C3500 Crew Cab		
		88-00	Chevrolet C3500 Regular & Extended Cabs		
		92-00	Chevrolet K2500 Crew Cab		
		88-99	Chevrolet K2500 Regular & Extended Cabs		
		92-00	Chevrolet K3500 Crew Cab		
		88-00	Chevrolet K3500 Regular & Extended Cabs		
		88-00	GMC C2500		
		88-00	GMC C3500		
		88-00	GMC K2500		
		88-00	GMC K3500		
52	45507	96-17	Chevrolet Express 2500	58	45
		96-17	Chevrolet Express 3500		
		96-17	GMC Savana 2500		
		96-17	GMC Savana 3500		
60	45508	99-16	Ford F-250 Super Duty Except Cab & Chassis	92	50
		99-16	Ford F-350 Super Duty Except Cab & Chassis		
		08-15	Ford F-450 Super Duty Except Cab & Chassis		
66	45509	03-10	Dodge Ram 2500	94	95
		03-10	Dodge Ram 3500		
		11-17	RAM 2500		
		11-17	RAM 3500		
67	45510	11-14	Chevrolet Silverado 2500 HD	82	60
		11-14	Chevrolet Silverado 3500 HD		
		11-14	GMC Sierra 2500 HD		
		11-14	GMC Sierra 3500 HD		
57	45511	15-16	Chevrolet Silverado 2500 HD	92	60
		15-16	Chevrolet Silverado 3500 HD		
		15-16	GMC Sierra 2500 HD		
		15-16	GMC Sierra 3500 HD		
59	45512	99-04	Chevrolet Silverado 2500	71	20
		99-04	GMC Sierra 2500		
54	45513	99-02	Dodge Ram 2500	63	30
		99-02	Dodge Ram 3500		
72	45514	99-04	Ford F-250 Super Duty w/Deep Drop Bumper	68	20
		99-04	Ford F-350 Super Duty w/Deep Drop Bumper		
53	45515	00-02	Chevrolet Suburban 2500 w/Amber Turn Signals	59	50
		00-06	GMC Yukon XL 2500		
65	45516	99-00	Ford F-350 Super Duty Cab & Chassis, w/34" Wide Frames	64	60
		99-16	Ford F-450 Super Duty Cab & Chassis, w/34" Wide Frames		
		99-16	Ford F-550 Super Duty Cab & Chassis, w/34" Wide Frames		
58	45517	01-10	Chevrolet Silverado 2500 HD	64	25
		03-07	Chevrolet Silverado 2500 HD (Classic)		
		01-02	Chevrolet Silverado 3500		
		03-07	Chevrolet Silverado 3500 (Classic)		
		07-10	Chevrolet Silverado 3500 HD		
		01-10	GMC Sierra 2500 HD		
		03-07	GMC Sierra 2500 HD (Classic)		
		01-02	GMC Sierra 3500		
03-07	GMC Sierra 3500 (Classic)				
07-10	GMC Sierra 3500 HD				
64	45518	06-08	Dodge Ram 1500	76	35
		03	Dodge Ram 1500 (Built After 11/2002)		
		04-05	Dodge Ram 1500 Except Daytona/Hemi Sport Quad Cab/Ram Rumble Bee/SRT-10		
		03-05	Dodge Ram 2500		
		06-10	Dodge Ram 2500 Except Mega Cab		
		03-05	Dodge Ram 3500		
		06-10	Dodge Ram 3500 Except Mega Cab		
		11-17	RAM 2500 Except Mega Cab		
		11-17	RAM 3500 Except Mega Cab		
		60	45519		
03-07	Chevrolet Silverado 2500 HD 8 ft. Bed (Classic)				
01-02	Chevrolet Silverado 3500				
03-07	Chevrolet Silverado 3500 (Classic)				
07-10	Chevrolet Silverado 3500 HD				
01-10	GMC Sierra 2500 HD 8 ft. Bed				
07	GMC Sierra 2500 HD 8 ft. Bed (Classic)				
01-02	GMC Sierra 3500				
03-07	GMC Sierra 3500 (Classic)				
07-10	GMC Sierra 3500 HD				
FRONT MOUNT RECEIVER					
28	65001	91-07	Ford E-150 Econoline	37	20
		91-07	Ford E-250 Econoline		

FRONT MOUNT RECEIVER HITCH APPLICATION NUMERICAL

PC	PART NO.	YEARS	MAKE/MODEL	WGT LBS	IN
28	65001	91-07	Ford E-350 Econoline Inc. RV Cutaway	37	20
		03-07	Ford E-450 Econoline Super Duty RV Cutaway		20
		00-02	Ford E-450 Econoline Super Duty Stripped RV Cutaway		20
37	65003	94-01	Dodge Ram 1500	39	30
		94-02	Dodge Ram 2500		30
		94-02	Dodge Ram 3500		30
24	65004	95-05	Chevrolet Blazer Downsize		30
		99-01	Chevrolet Blazer Trailblazer		30
		94-04	Chevrolet S10		30
		95-05	GMC Jimmy Downsize		30
		94-04	GMC Sonoma		30
		96-00	Isuzu Hombre		30
		96-01	Oldsmobile Bravada		30
21	65005	92-94	Chevrolet Blazer Full Size	31	40
		88-99	Chevrolet C1500 2 Dr. Regular & Extended Cabs		40
		88-99	Chevrolet C2500 2 Dr. Regular & Extended Cabs		40
		88-00	Chevrolet C3500 2 Dr. Regular & Extended Cabs		40
		88-99	Chevrolet K1500 2 Dr. Regular & Extended Cabs		40
		88-99	Chevrolet K2500 2 Dr. Regular & Extended Cabs		40
		92-00	Chevrolet K2500 4 Dr. Crew Cab		40
		88-00	Chevrolet K3500 2 Dr. Regular & Extended Cabs		40
		92-00	Chevrolet K3500 4 Dr. Crew Cab		40
		92-99	Chevrolet Suburban C1500		40
		92-99	Chevrolet Suburban C2500		40
		92-99	Chevrolet Suburban K1500		40
		92-99	Chevrolet Suburban K2500		40
		95-00	Chevrolet Tahoe		40
		88-99	GMC C1500 2 Dr. Regular & Extended Cabs		40
		88-00	GMC C2500 2 Dr. Regular & Extended Cabs		40
		88-00	GMC C3500 2 Dr. Regular & Extended Cabs		40
		88-99	GMC K1500 2 Dr. Regular & Extended Cabs		40
		92-99	GMC K1500 4 Dr. Crew Cab		40
		92-00	GMC K2500 4 Dr. Crew Cab		40
		92-00	GMC K3500 4 Dr. Crew Cab		40
		92-99	GMC Suburban C1500		40
		92-99	GMC Suburban C2500		40
		92-99	GMC Suburban K1500		40
		92-99	GMC Suburban K2500		40
		92-00	GMC Yukon		40
		53	65008	93-98	Jeep Grand Cherokee
93	Jeep Grand Wagoneer				25
23	65009	84-01	Jeep Cherokee Downsize	29	30
		86-92	Jeep Comanche		30
		84-90	Jeep Wagoneer		30
32	65014	92-97	Ford F-250 Styleside	45	25
		92-97	Ford F-350 Styleside		25
30	65015	92-97	Ford F-250	36	25
		92-97	Ford F-350		25
24	65016	96-03	Chevrolet Express 1500 Inc. RV Cutaway	35	35
		96-03	Chevrolet Express 2500 Inc. RV Cutaway		35
		96-03	Chevrolet Express 3500 Inc. RV Cutaway		35
		96-03	GMC Savana 1500 Inc. RV Cutaway		35
		96-03	GMC Savana 2500 Inc. RV Cutaway		35
		96-03	GMC Savana 3500 Inc. RV Cutaway		35
52	65017	91-94	Ford Explorer	34	35
		89-97	Ford Ranger		35
		94-97	Mazda B2300		35
		94-97	Mazda B3000		35
		94-97	Mazda B4000		35
		91-94	Mazda Navajo		35
		46	65021	88-99	Chevrolet C1500 2 Dr. Regular & Extended Cabs
92-99	Chevrolet C1500 4 Dr. Crew Cab				30
88-99	Chevrolet C2500 2 Dr. Regular & Extended Cabs				30
92-00	Chevrolet C2500 4 Dr. Crew Cab				30
88-00	Chevrolet C3500 2 Dr. Regular & Extended Cabs				30
92-00	Chevrolet C3500 4 Dr. Crew Cab				30
92-99	Chevrolet Suburban C1500				30
92-99	Chevrolet Suburban C2500				30
92-99	Chevrolet Suburban K1500				30
92-99	Chevrolet Suburban K2500				30
88-99	GMC C1500 2 Dr. Regular & Extended Cabs				30
92-99	GMC C1500 4 Dr. Crew Cab				30
88-00	GMC C2500 2 Dr. Regular & Extended Cabs				30
92-00	GMC C2500 4 Dr. Crew Cab				30
88-00	GMC C3500 2 Dr. Regular & Extended Cabs				30
92-00	GMC C3500 4 Dr. Crew Cab				30
92-99	GMC Suburban C1500				30

PC	PART NO.	YEARS	MAKE/MODEL	WGT LBS	IN
46	65021	92-99	GMC Suburban C2500	32	30
		92-99	GMC Suburban K1500		30
		92-99	GMC Suburban K2500		30
34	65022	00-05	Ford Excursion	46	40
		99-07	Ford F-250 Super Duty		40
		99-07	Ford F-350 Super Duty		40
		99-07	Ford F-350 Super Duty Cab & Chassis, w/34" Wide Frames		40
		99-07	Ford F-450 Super Duty Cab & Chassis, w/34" Wide Frames		40
47	65023	99-07	Ford F-550 Super Duty Cab & Chassis, w/34" Wide Frames		40
		99-07	Chevrolet Silverado 1500	30	20
		00-06	Chevrolet Suburban 1500		20
		00-06	Chevrolet Tahoe 1500 Series		20
		99-07	GMC Sierra 1500 Except Denali (Classic)		20
		00-06	GMC Yukon 1500		20
		01-06	GMC Yukon Denali 1500		30
31	65024	00-06	GMC Yukon XL 1500		30
		01-06	GMC Yukon XL 1500 Denali		30
		01-05	Ford Ranger	39	35
		02-05	Mazda B2300		35
		01	Mazda B2500		35
35	65025	01-05	Mazda B3000		35
		01-05	Mazda B4000		35
		97-02	Ford Expedition	33	20
		97-03	Ford F-150		20
		04	Ford F-150 Heritage		20
24	65028	97-99	Ford F-250 Styleside		20
		98-02	Lincoln Navigator		20
		01-07	Chevrolet Silverado 1500 HD	30	20
		99-04	Chevrolet Silverado 2500		20
		01-07	Chevrolet Silverado 2500 HD		20
		01-07	Chevrolet Silverado 3500		20
		00-06	Chevrolet Suburban 2500		20
01-07	GMC Sierra 1500 HD		20		
42	65029	99-04	GMC Sierra 2500		20
		01-07	GMC Sierra 2500 HD		20
		01-07	GMC Sierra 3500		20
		00-06	GMC Yukon XL 2500		20
		00-04	Dodge Dakota 4 WD	44	25
29	65030	00-03	Dodge Durango 4 WD		25
		01-03	Ford Explorer 2 Dr. Sport	21	25
30	65031	01-05	Ford Explorer Sport Trac		25
		01-07	Toyota Sequoia	41	40
32	65032	00-06	Toyota Tundra		40
		02-05	Ford Explorer 4 Dr.	34	30
49	65033	02-05	Mercury Mountaineer		30
		02-05	Dodge Ram 1500	43	25
31	65041	01-04	Toyota Tacoma	31	30
22	65043	04-08	Ford F-150	38	20
34	65046	06-08	Lincoln Mark LT		20
		03-09	Dodge Ram 2500	42	40
23	65048	03-09	Dodge Ram 3500		40
		97-06	Jeep TJ (Canada Only)	24	25
30	65049	87-06	Jeep Wrangler		25
		87-95	Jeep YJ (Canada Only)		25
22	65050	08-16	Ford F-250 Super Duty	35	20
		08-16	Ford F-350 Super Duty		20
		08-16	Ford F-350 Super Duty Cab & Chassis		20
		08-16	Ford F-450 Super Duty		20
		08-16	Ford F-450 Super Duty Cab & Chassis		20
		08-16	Ford F-550 Super Duty Cab & Chassis		20
16	65051	07-10	Chevrolet Silverado 2500 HD	29	40
		07-10	Chevrolet Silverado 3500 HD		40
		07-10	GMC Sierra 2500 HD		40
		07-10	GMC Sierra 3500 HD		40
30	65052	07-17	Toyota Tundra	35	25
		07-13	Chevrolet Avalanche Except Z71	40	25
		07-13	Chevrolet Silverado 1500		25
		07-14	Chevrolet Suburban 1500 Except Z71		25
		07-14	Chevrolet Tahoe Except Z71		25
		07-13	GMC Sierra 1500		25
		07-14	GMC Yukon		25
19	65053	07-14	GMC Yukon XL 1500		25
		08-14	Ford E-150 Econoline	32	40
		08-14	Ford E-250 Econoline		40
		08-14	Ford E-350 Econoline Super Duty		50
		08-12	Ford E-350 Econoline Super Duty RV Cutaway		50
08-12	Ford E-450 Econoline Super Duty RV Cutaway		50		

BRAKE CONTROL HARNESS APPLICATION NUMERICAL

PC	PART NO.	YEARS	MAKE/MODEL	WGT LBS	IN
35	65057	10	Dodge Ram 2500 4 WD	32	40
		11-12	RAM 2500 4 WD	41	40
38	65060	10	Dodge Ram 3500	38	30
		11-12	RAM 3500	30	30
34	65061	09-14	Ford F-150	42	30
		10-13	Lincoln Mark LT (Mexico Only)	30	30
32	65062	09-10	Dodge Ram 1500	43	35
		11-17	RAM 1500	35	35
33	65063	10	Dodge Ram 2500	24	30
		10	Dodge Ram 3500	30	30
		11-17	RAM 2500	30	30
		11-17	RAM 3500	30	30
30	65064	14-17	Chevrolet Silverado 1500	35	25
		15-16	Chevrolet Suburban	25	25
		15-16	Chevrolet Tahoe	25	25
		14-17	GMC Sierra 1500	25	25
		15-16	GMC Yukon	25	25
		15-16	GMC Yukon XL	25	25
44	65065	09-15	Nissan Titan 4 WD Only	45	45
31	65067	15-16	Ford F-150	37	30
26	65068	11-16	Chevrolet Silverado 2500 HD	26	35
		11-16	Chevrolet Silverado 2500 HD	45	35
		11-16	Chevrolet Silverado 3500 HD	35	35
		11-16	Chevrolet Silverado 3500 HD	45	35
		11-16	GMC Sierra 2500 HD Except Denali	35	35
		11-16	GMC Sierra 2500 HD Except Denali	45	35
		11-16	GMC Sierra 3500 HD Except Denali	35	35
		11-16	GMC Sierra 3500 HD Except Denali	45	35
19	65069	07-17	Jeep Wrangler Except Models with Adaptable Bumper Design	22	40
52	65070	05-16	Toyota Tacoma	47	35
23	65071	15-16	Chevrolet Colorado	32	30
		15-16	GMC Canyon	30	30
30	65072	16	Nissan Titan XD	29	25
27	65073	17	Honda Ridgeline	35	35
1 - PLUG ADAPTERS					
	20277†	13-14	RAM 1500		5
		13-14	RAM 2500		5
		13-14	RAM 3500		5
	3014-S	14-16	Jeep Cherokee		5
	3015-S	03-06	Cadillac Escalade		5
		03-06	Cadillac Escalade ESV		5
		03-06	Cadillac Escalade EXT		5
		03-06	Chevrolet Avalanche 1500		5
		03-06	Chevrolet Avalanche 2500		5
		03-06	Chevrolet Silverado 1500		5
		07	Chevrolet Silverado 1500 (Classic)		5
		03-06	Chevrolet Silverado 1500 HD		5
		07	Chevrolet Silverado 1500 HD (Classic)		5
		03-04	Chevrolet Silverado 2500		5
		03-06	Chevrolet Silverado 2500 HD		5
		07	Chevrolet Silverado 2500 HD (Classic)		5
		03-06	Chevrolet Silverado 3500		5
		07	Chevrolet Silverado 3500 (Classic)		5
		03-06	Chevrolet Suburban 1500		5
		03-06	Chevrolet Suburban 2500		5
		03-06	Chevrolet Tahoe		5
		03-06	GMC Sierra 1500		5
		07	GMC Sierra 1500 (Classic)		5
		03-06	GMC Sierra 1500 HD		5
		07	GMC Sierra 1500 HD (Classic)		5
		03-04	GMC Sierra 2500		5
		03-06	GMC Sierra 2500 HD		5
		07	GMC Sierra 2500 HD (Classic)		5
		03-06	GMC Sierra 3500		5
		07	GMC Sierra 3500 (Classic)		5
		03-06	GMC Yukon		5
		03-06	GMC Yukon Denali		5
		03-06	GMC Yukon XL 1500		5
		03-06	GMC Yukon XL 1500 Denali		5
		03-06	GMC Yukon XL 2500		5
		03-07	Hummer H2		5
	3016-S	15-16	Cadillac Escalade		5
		14-16	Chevrolet Silverado 1500		5
		15-16	Chevrolet Silverado 2500 HD		5
		15-16	Chevrolet Silverado 3500 HD		5
		15-16	Chevrolet Suburban		5
		15-16	Chevrolet Tahoe		5

PC	PART NO.	YEARS	MAKE/MODEL	WGT LBS	IN
	3016-S	14-16	GMC Sierra 1500		5
		15-16	GMC Sierra 2500 HD		5
		15-16	GMC Sierra 3500 HD		5
		15-16	GMC Yukon		5
	3017-S	16-17	Toyota Tacoma		5
		15-16	Toyota Tundra		5
	3020-S	07-09	Chrysler Aspen w/Factory Tow Package		5
		97-10	Dodge Dakota w/Factory Tow Package		5
		98-09	Dodge Durango w/Factory Tow Package		5
		95-09	Dodge Ram 1500		5
		95-09	Dodge Ram 2500		5
		95-09	Dodge Ram 3500		5
		11	RAM Dakota w/Factory Tow Package		5
	3021-S	10	Dodge Ram 1500		5
		10	Dodge Ram 2500		5
		10	Dodge Ram 3500		5
		11-12	RAM 1500		5
		11-12	RAM 2500		5
		11-12	RAM 3500		5
	3023-S	13-14	RAM 1500		5
		13-14	RAM 2500		5
		13-14	RAM 3500		5
	3025-S	02	Cadillac Escalade		5
		02	Cadillac Escalade EXT		5
		02	Chevrolet Avalanche 1500		5
		02	Chevrolet Avalanche 2500		5
		99-02	Chevrolet Silverado 1500		5
		01-02	Chevrolet Silverado 1500 HD		5
		99-02	Chevrolet Silverado 2500		5
		01-02	Chevrolet Silverado 2500 HD		5
		01-02	Chevrolet Silverado 3500		5
		00-02	Chevrolet Suburban 1500 w/Amber Turn Signals		5
		00-02	Chevrolet Suburban 2500 w/Amber Turn Signals		5
		00-02	Chevrolet Tahoe w/Amber Turn Signals		5
		99-02	GMC Sierra 1500		5
		01-02	GMC Sierra 1500 HD		5
		99-02	GMC Sierra 2500		5
		01-02	GMC Sierra 2500 HD		5
		01-02	GMC Sierra 3500		5
		01-02	GMC Yukon Denali w/Amber Turn Signals		5
		00-02	GMC Yukon w/Amber Turn Signals		5
		00-02	GMC Yukon XL 1500		5
		01-02	GMC Yukon XL 1500 Denali		5
		00-02	GMC Yukon XL 2500		5
	3026-S	08-16	Buick Enclave w/Factory 7-Way		5
		09-16	Chevrolet Traverse w/Factory 7-Way		5
		07-16	GMC Acadia w/Factory 7-Way		5
		07-09	Saturn Outlook w/Factory 7-Way		5
	3034-S	09-14	Ford E-150 Econoline		20
		09-14	Ford E-250 Econoline		20
		09-14	Ford E-350 Econoline Super Duty		20
		09-11	Ford E-350 Econoline Super Duty RV Cutaway, w/Factory Tow Prep Plug		20
		09-11	Ford E-450 Econoline Super Duty RV Cutaway, w/Factory Tow Prep Plug		20
		13-14	Ford Expedition		20
		08-16	Ford F-250 Super Duty		20
		08-16	Ford F-350 Super Duty		20
		08-16	Ford F-350 Super Duty Cab & Chassis		20
		08-16	Ford F-450 Super Duty		20
		08-16	Ford F-450 Super Duty Cab & Chassis		20
		08-16	Ford F-550 Super Duty Cab & Chassis		20
		13-14	Lincoln Navigator		20
	3035-S	94-96	Ford Bronco		5
		92-08	Ford E-150 Econoline		5
		92-08	Ford E-250 Econoline		5
		92-08	Ford E-350 Econoline		5
		92-08	Ford E-350 Econoline RV Cutaway, w/Factory Tow Prep Plug		5
		03-08	Ford E-450 Econoline Super Duty RV Cutaway, w/Factory Tow Prep Plug		5
		00-02	Ford E-450 Econoline Super Duty Stripped RV Cutaway, w/Factory Tow Prep Plug		5
		00-05	Ford Excursion		5
		97-12	Ford Expedition		5
		07-10	Ford Explorer Sport Trac w/Factory Tow Package		5
		02-16	Ford Explorer w/Factory Tow Package		5
		94-08	Ford F-150		5

BRAKE CONTROL HARNESS APPLICATION NUMERICAL

PC	PART NO.	YEARS	MAKE/MODEL	WGT LBS	IN
	3035-S	04	Ford F-150 Heritage		5
		94-96	Ford F-250		5
		97	Ford F-250 Heavy Duty		5
		97-99	Ford F-250 Styleside		5
		99-04	Ford F-250 Super Duty		5
		94-96	Ford F-350		5
		97	Ford F-350 Heavy Duty		5
		99-04	Ford F-350 Super Duty		5
		99-04	Ford F-450 Super Duty Cab & Chassis		5
		99-04	Ford F-550 Super Duty Cab & Chassis		5
		09-11	Ford Flex w/Factory Tow Package		5
		95-03	Ford Windstar w/Factory Tow Package		5
		05-09	Land Rover LR3		5
		10-15	Land Rover LR4		5
		05-15	Land Rover Range Rover		5
		12-16	Land Rover Range Rover Evoque		5
		03-05	Lincoln Aviator w/Factory Tow Package		5
		06-08	Lincoln Mark LT		5
		10-11	Lincoln MKT w/Factory Tow Package		5
		98-12	Lincoln Navigator		5
		02-10	Mercury Mountaineer w/Factory Tow Package		5
	3036-S	09-16	Ford F-150		20
		12-16	Ford Flex w/Factory Tow Package		20
		12-15	Lincoln MKT w/Factory Tow Package		20
	3040-S	10-15	Lexus GX460		5
		03-09	Lexus GX470		5
		03-07	Lexus LX470		5
		08-15	Lexus LX570		5
		03-13	Toyota 4Runner		5
		03-15	Toyota Land Cruiser		5
		03-15	Toyota Sequoia		5
		07-15	Toyota Tacoma		5
		03-14	Toyota Tundra		5
	3045-S	11-14	Dodge Durango w/Factory Tow Package		5
		11-15	Jeep Grand Cherokee w/Factory Tow Package		5
	3050-S	04-13	Infiniti QX56		5
		05-15	Nissan Armada		5
		05-15	Nissan Frontier		5
		13-15	Nissan NV1500		5
		13-15	Nissan NV2500		5
		13-15	Nissan NV3500		5
		05-16	Nissan Pathfinder		5
		04	Nissan Pathfinder Armada		5
		04-16	Nissan Titan		5
		05-15	Nissan Xterra w/Factory Tow Package		5
	3065-S	05-07	Ford F-250 Super Duty		5
		05-07	Ford F-350 Super Duty		5
		05-07	Ford F-350 Super Duty Cab & Chassis		5
		05-07	Ford F-450 Super Duty Cab & Chassis		5
		05-07	Ford F-550 Super Duty Cab & Chassis		5
	3070-S	09-16	Honda Pilot w/Factory Tow Package		5
		06-14	Honda Ridgeline w/Factory Tow Package		5
2 - PLUG ADAPTERS					
	22291t	09-11	KIA Borrego		5
	3014	14-16	Jeep Cherokee		5
	3014-P	14-16	Jeep Cherokee		5
	3015	03-06	Cadillac Escalade		5
		03-06	Cadillac Escalade ESV		5
		03-06	Cadillac Escalade EXT		5
		03-06	Chevrolet Avalanche 1500		5
		03-06	Chevrolet Avalanche 2500		5
		03-06	Chevrolet Silverado 1500		5
		07	Chevrolet Silverado 1500 (Classic)		5
		03-06	Chevrolet Silverado 1500 HD		5
		07	Chevrolet Silverado 1500 HD (Classic)		5
		03-04	Chevrolet Silverado 2500		5
		03-06	Chevrolet Silverado 2500 HD		5
		07	Chevrolet Silverado 2500 HD (Classic)		5
		03-06	Chevrolet Silverado 3500		5
		07	Chevrolet Silverado 3500 (Classic)		5
		03-06	Chevrolet Suburban 1500		5
		03-06	Chevrolet Suburban 2500		5
		03-06	Chevrolet Tahoe		5
		03-06	GMC Sierra 1500		5
		07	GMC Sierra 1500 (Classic)		5
		03-06	GMC Sierra 1500 HD		5
		07	GMC Sierra 1500 HD (Classic)		5
		03-06	GMC Sierra 2500		5
		07	GMC Sierra 2500 (Classic)		5
		03-06	GMC Sierra 2500 HD		5
		07	GMC Sierra 2500 HD (Classic)		5
		03-06	GMC Sierra 3500		5
		07	GMC Sierra 3500 (Classic)		5
		03-06	GMC Sierra 3500 HD		5
		07	GMC Sierra 3500 HD (Classic)		5
		03-06	GMC Yukon		5
		03-06	GMC Yukon Denali		5
		03-06	GMC Yukon XL 1500		5
		03-06	GMC Yukon XL 1500 Denali		5
		03-06	GMC Yukon XL 2500		5
		03-07	Hummer H2		5

PC	PART NO.	YEARS	MAKE/MODEL	WGT LBS	IN
	3015	03-04	GMC Sierra 2500		5
		03-06	GMC Sierra 2500 HD		5
		07	GMC Sierra 2500 HD (Classic)		5
		03-06	GMC Sierra 3500		5
		07	GMC Sierra 3500 (Classic)		5
		03-06	GMC Yukon		5
		03-06	GMC Yukon Denali		5
		03-06	GMC Yukon XL 1500		5
		03-06	GMC Yukon XL 1500 Denali		5
		03-06	GMC Yukon XL 2500		5
		03-07	Hummer H2		5
	3015-P	03-06	Cadillac Escalade		5
		03-06	Cadillac Escalade ESV		5
		03-06	Cadillac Escalade EXT		5
		03-06	Chevrolet Avalanche 1500		5
		03-06	Chevrolet Avalanche 2500		5
		03-06	Chevrolet Silverado 1500		5
		07	Chevrolet Silverado 1500 (Classic)		5
		03-06	Chevrolet Silverado 1500 HD		5
		07	Chevrolet Silverado 1500 HD (Classic)		5
		03-04	Chevrolet Silverado 2500		5
		03-06	Chevrolet Silverado 2500 HD		5
		07	Chevrolet Silverado 2500 HD (Classic)		5
		03-06	Chevrolet Silverado 3500		5
		07	Chevrolet Silverado 3500 (Classic)		5
		03-06	Chevrolet Suburban 1500		5
		03-06	Chevrolet Suburban 2500		5
		03-06	Chevrolet Tahoe		5
		07	GMC Sierra 1500 (Classic)		5
		03-06	GMC Sierra 1500 HD		5
		07	GMC Sierra 1500 HD (Classic)		5
		03-04	GMC Sierra 2500		5
		03-06	GMC Sierra 2500 HD		5
		07	GMC Sierra 2500 HD (Classic)		5
		03-06	GMC Sierra 3500		5
		07	GMC Sierra 3500 (Classic)		5
		03-06	GMC Sierra 3500 HD		5
		07	GMC Sierra 3500 HD (Classic)		5
		03-06	GMC Sierra 3500		5
		07	GMC Sierra 3500 (Classic)		5
		03-06	GMC Yukon		5
		03-06	GMC Yukon Denali		5
		03-06	GMC Yukon XL 1500		5
		03-06	GMC Yukon XL 1500 Denali		5
		03-06	GMC Yukon XL 2500		5
		03-07	Hummer H2		5
	3016	15-16	Cadillac Escalade		5
		14-16	Chevrolet Silverado 1500		5
		15-16	Chevrolet Silverado 2500 HD		5
		15-16	Chevrolet Silverado 3500 HD		5
		15-16	Chevrolet Suburban		5
		15-16	Chevrolet Tahoe		5
		14-16	GMC Sierra 1500		5
		15-16	GMC Sierra 2500 HD		5
		15-16	GMC Sierra 3500 HD		5
		15-16	GMC Yukon		5
	3016-P	15-16	Cadillac Escalade		5
		14-16	Chevrolet Silverado 1500		5
		15-16	Chevrolet Silverado 2500 HD		5
		15-16	Chevrolet Silverado 3500 HD		5
		15-16	Chevrolet Suburban		5
		15-16	Chevrolet Tahoe		5
		14-16	GMC Sierra 1500		5
		15-16	GMC Sierra 2500 HD		5
		15-16	GMC Sierra 3500 HD		5
		15-16	GMC Yukon		5
	3017	16-17	Toyota Tacoma		5
		15-16	Toyota Tundra		5
	3017-P	16-17	Toyota Tacoma		5
		15-16	Toyota Tundra		5
	3020	07-09	Chrysler Aspen w/Factory Tow Package		5
		97-10	Dodge Dakota w/Factory Tow Package		5
		98-09	Dodge Durango w/Factory Tow Package		5
		95-09	Dodge Ram 1500		5
		95-09	Dodge Ram 2500		5
		95-09	Dodge Ram 3500		5
		11	RAM Dakota w/Factory Tow Package		5
	3020-P	07-09	Chrysler Aspen w/Factory Tow Package		5
		97-10	Dodge Dakota w/Factory Tow Package		5
		98-09	Dodge Durango w/Factory Tow Package		5

BRAKE CONTROL HARNESS APPLICATION NUMERICAL

PC	PART NO.	YEARS	MAKE/MODEL	WGT LBS	IN
	3020-P	95-09	Dodge Ram 1500		5
		95-09	Dodge Ram 2500		5
		95-09	Dodge Ram 3500		5
		11	RAM Dakota w/Factory Tow Package		5
	3021	10	Dodge Ram 1500		5
		10	Dodge Ram 2500		5
		10	Dodge Ram 3500		5
		11-12	RAM 1500		5
		11-12	RAM 2500		5
		11-12	RAM 3500		5
	3021-P	10	Dodge Ram 1500		5
		10	Dodge Ram 2500		5
		10	Dodge Ram 3500		5
		11-12	RAM 1500		5
		11-12	RAM 2500		5
		11-12	RAM 3500		5
	3023	13-14	RAM 1500		10
		13-14	RAM 2500		10
		13-14	RAM 3500		10
	30234-P	13-14	RAM 1500	2	45
		13-14	RAM 2500		45
		13-14	RAM 3500		45
	30235	13-16	RAM 1500	1	30
		13-16	RAM 2500		30
		13-16	RAM 3500		30
	30235-P	13-16	RAM 1500	2	30
		13-16	RAM 2500		30
		13-16	RAM 3500		30
	3023-P	13-14	RAM 1500		10
		13-14	RAM 2500		10
		13-14	RAM 3500		10
	3024	15-16	RAM 1500		5
		15-16	RAM 2500		5
		15-16	RAM 3500		5
	3024-P	15-16	RAM 1500		5
		15-16	RAM 2500		5
		15-16	RAM 3500		5
	3025	02	Cadillac Escalade		5
		02	Cadillac Escalade EXT		5
		02	Chevrolet Avalanche 1500		5
		02	Chevrolet Avalanche 2500		5
		99-02	Chevrolet Silverado 1500		5
		01-02	Chevrolet Silverado 1500 HD		5
		99-02	Chevrolet Silverado 2500		5
		01-02	Chevrolet Silverado 2500 HD		5
		01-02	Chevrolet Silverado 3500		5
		00-02	Chevrolet Suburban 1500 w/Amber Turn Signals		5
		00-02	Chevrolet Suburban 2500 w/Amber Turn Signals		5
		00-02	Chevrolet Tahoe w/Amber Turn Signals		5
		99-02	GMC Sierra 1500		5
		01-02	GMC Sierra 1500 HD		5
		99-02	GMC Sierra 2500		5
		01-02	GMC Sierra 2500 HD		5
		01-02	GMC Sierra 3500		5
		01-02	GMC Yukon Denali w/Amber Turn Signals		5
		00-02	GMC Yukon w/Amber Turn Signals		5
		00-02	GMC Yukon XL 1500		5
		01-02	GMC Yukon XL 1500 Denali		5
		00-02	GMC Yukon XL 2500		5
	3025-P	02	Cadillac Escalade		5
		02	Cadillac Escalade EXT		5
		02	Chevrolet Avalanche 1500		5
		02	Chevrolet Avalanche 2500		5
		99-02	Chevrolet Silverado 1500		5
		01-02	Chevrolet Silverado 1500 HD		5
		99-02	Chevrolet Silverado 2500		5
		01-02	Chevrolet Silverado 2500 HD		5
		01-02	Chevrolet Silverado 3500		5
		00-02	Chevrolet Suburban 1500 w/Amber Turn Signals		5
		00-02	Chevrolet Suburban 2500 w/Amber Turn Signals		5
		00-02	Chevrolet Tahoe w/Amber Turn Signals		5
		99-02	GMC Sierra 1500		5
		01-02	GMC Sierra 1500 HD		5
		99-02	GMC Sierra 2500		5
		01-02	GMC Sierra 2500 HD		5
		01-02	GMC Sierra 3500		5
		01-02	GMC Yukon Denali w/Amber Turn Signals		5

PC	PART NO.	YEARS	MAKE/MODEL	WGT LBS	IN
	3025-P	00-02	GMC Yukon w/Amber Turn Signals		5
		00-02	GMC Yukon XL 1500		5
		01-02	GMC Yukon XL 1500 Denali		5
		00-02	GMC Yukon XL 2500		5
	3026	08-16	Buick Enclave w/Factory 7-Way		5
		09-16	Chevrolet Traverse w/Factory 7-Way		5
		07-16	GMC Acadia w/Factory 7-Way		5
		07-09	Saturn Outlook w/Factory 7-Way		5
	3026-P	08-16	Buick Enclave w/Factory 7-Way		5
		09-16	Chevrolet Traverse w/Factory 7-Way		5
		07-16	GMC Acadia w/Factory 7-Way		5
		07-09	Saturn Outlook w/Factory 7-Way		5
	3032	09-11	KIA Borrego		5
	3032-P	09-11	KIA Borrego		5
	3034	09-14	Ford E-150 Econoline		20
		09-14	Ford E-250 Econoline		20
		09-14	Ford E-350 Econoline Super Duty		20
		09-11	Ford E-350 Econoline Super Duty RV Cutaway, w/Factory Tow Prep Plug		20
		09-11	Ford E-450 Econoline Super Duty RV Cutaway, w/Factory Tow Prep Plug		20
		13-14	Ford Expedition		20
		08-16	Ford F-250 Super Duty		20
		08-16	Ford F-350 Super Duty		20
		08-16	Ford F-350 Super Duty Cab & Chassis		20
		08-16	Ford F-450 Super Duty		20
		08-16	Ford F-450 Super Duty Cab & Chassis		20
		08-16	Ford F-550 Super Duty Cab & Chassis		20
		13-14	Lincoln Navigator		20
	3034-P	09-14	Ford E-150 Econoline		20
		09-14	Ford E-250 Econoline		20
		09-14	Ford E-350 Econoline Super Duty		20
		09-11	Ford E-350 Econoline Super Duty RV Cutaway, w/Factory Tow Prep Plug		20
		09-11	Ford E-450 Econoline Super Duty RV Cutaway, w/Factory Tow Prep Plug		20
		13-14	Ford Expedition		20
		08-16	Ford F-250 Super Duty		20
		08-16	Ford F-350 Super Duty		20
		08-16	Ford F-350 Super Duty Cab & Chassis		20
		08-16	Ford F-450 Super Duty		20
		08-16	Ford F-450 Super Duty Cab & Chassis		20
		08-16	Ford F-550 Super Duty Cab & Chassis		20
		13-14	Lincoln Navigator		20
	3035	94-96	Ford Bronco		5
		92-08	Ford E-150 Econoline		5
		92-08	Ford E-250 Econoline		5
		92-08	Ford E-350 Econoline		5
		92-08	Ford E-350 Econoline RV Cutaway, w/Factory Tow Prep Plug		5
		03-08	Ford E-450 Econoline Super Duty RV Cutaway, w/Factory Tow Prep Plug		5
		00-02	Ford E-450 Econoline Super Duty Stripped RV Cutaway, w/Factory Tow Prep Plug		5
		00-05	Ford Excursion		5
		97-12	Ford Expedition		5
		07-10	Ford Explorer Sport Trac w/Factory Tow Package		5
		02-16	Ford Explorer w/Factory Tow Package		5
		94-08	Ford F-150		5
		04	Ford F-150 Heritage		5
		94-96	Ford F-250		5
		97	Ford F-250 Heavy Duty		5
		97-99	Ford F-250 Styleside		5
		99-04	Ford F-250 Super Duty		5
		94-96	Ford F-350		5
		97	Ford F-350 Heavy Duty		5
		99-04	Ford F-350 Super Duty		5
		99-04	Ford F-450 Super Duty Cab & Chassis		5
		99-04	Ford F-550 Super Duty Cab & Chassis		5
		09-11	Ford Flex w/Factory Tow Package		5
		95-03	Ford Windstar w/Factory Tow Package		5
		05-09	Land Rover LR3		5
		10-15	Land Rover LR4		5
		05-15	Land Rover Range Rover		5
		12-16	Land Rover Range Rover Evoque		5
		03-05	Lincoln Aviator w/Factory Tow Package		5
		06-08	Lincoln Mark LT		5
		10-11	Lincoln MKT w/Factory Tow Package		5

T-ONE CONNECTOR APPLICATION NUMERICAL

PC	PART NO.	YEARS	MAKE/MODEL	WGT LBS	IN
	3035	98-12	Lincoln Navigator		5
		02-10	Mercury Mountaineer w/Factory Tow Package		5
	3035-P	94-96	Ford Bronco		5
		92-08	Ford E-150 Econoline		5
		92-08	Ford E-250 Econoline		5
		92-08	Ford E-350 Econoline		5
		92-08	Ford E-350 Econoline RV Cutaway, w/Factory Tow Prep Plug		5
		03-08	Ford E-450 Econoline Super Duty RV Cutaway, w/Factory Tow Prep Plug		5
		00-02	Ford E-450 Econoline Super Duty Stripped RV Cutaway, w/Factory Tow Prep Plug		5
		00-05	Ford Excursion		5
		97-12	Ford Expedition		5
		07-10	Ford Explorer Sport Trac w/Factory Tow Package		5
		02-16	Ford Explorer w/Factory Tow Package		5
		94-08	Ford F-150		5
		04	Ford F-150 Heritage		5
		94-96	Ford F-250		5
		97	Ford F-250 Heavy Duty		5
		97-99	Ford F-250 Styleside		5
		99-04	Ford F-250 Super Duty		5
		94-96	Ford F-350		5
		97	Ford F-350 Heavy Duty		5
		99-04	Ford F-350 Super Duty		5
		99-04	Ford F-450 Super Duty Cab & Chassis		5
		99-04	Ford F-550 Super Duty Cab & Chassis		5
		09-11	Ford Flex w/Factory Tow Package		5
		95-03	Ford Windstar w/Factory Tow Package		5
		05-09	Land Rover LR3		5
		10-15	Land Rover LR4		5
		05-15	Land Rover Range Rover		5
		12-16	Land Rover Range Rover Evoque		5
		03-05	Lincoln Aviator w/Factory Tow Package		5
		06-08	Lincoln Mark LT		5
		10-11	Lincoln MKT w/Factory Tow Package		5
		98-12	Lincoln Navigator		5
		02-10	Mercury Mountaineer w/Factory Tow Package		5
	3036	09-16	Ford F-150		20
		12-16	Ford Flex w/Factory Tow Package		20
		12-15	Lincoln MKT w/Factory Tow Package		20
	3036-P	09-16	Ford F-150		20
		12-16	Ford Flex w/Factory Tow Package		20
		12-15	Lincoln MKT w/Factory Tow Package		20
	3040	10-15	Lexus GX460		5
		03-09	Lexus GX470		5
		03-07	Lexus LX470		5
		08-15	Lexus LX570		5
		03-13	Toyota 4Runner		5
		03-15	Toyota Land Cruiser		5
		03-15	Toyota Sequoia		5
		07-15	Toyota Tacoma		5
		03-14	Toyota Tundra		5
	3040-P	10-15	Lexus GX460		5
		03-09	Lexus GX470		5
		03-07	Lexus LX470		5
		08-15	Lexus LX570		5
		03-13	Toyota 4Runner		5
		03-15	Toyota Land Cruiser		5
		03-15	Toyota Sequoia		5
		07-15	Toyota Tacoma		5
		03-14	Toyota Tundra		5
	3041	14-16	Toyota 4Runner		10
	3041-P	14-16	Toyota 4Runner		10
	3045	11-14	Dodge Durango w/Factory Tow Package		5
		11-15	Jeep Grand Cherokee w/Factory Tow Package		5
	3045-P	11-14	Dodge Durango w/Factory Tow Package		5
		11-15	Jeep Grand Cherokee w/Factory Tow Package		5
	3050	04-13	Infiniti QX56		5
		05-15	Nissan Armada		5
		05-15	Nissan Frontier		5
		13-15	Nissan NV1500		5
		13-15	Nissan NV2500		5
		13-15	Nissan NV3500		5
		05-16	Nissan Pathfinder		5
		04	Nissan Pathfinder Armada		5
		04-16	Nissan Titan		5
		05-15	Nissan Xterra w/Factory Tow Package		5

PC	PART NO.	YEARS	MAKE/MODEL	WGT LBS	IN
	3050-P	04-13	Infiniti QX56		5
		05-15	Nissan Armada		5
		05-15	Nissan Frontier		5
		13-15	Nissan NV1500		5
		13-15	Nissan NV2500		5
		13-15	Nissan NV3500		5
		05-16	Nissan Pathfinder		5
		04	Nissan Pathfinder Armada		5
		04-16	Nissan Titan		5
		05-15	Nissan Xterra w/Factory Tow Package		5
	3065	05-07	Ford F-250 Super Duty		5
		05-07	Ford F-350 Super Duty		5
		05-07	Ford F-350 Super Duty Cab & Chassis		5
		05-07	Ford F-450 Super Duty Cab & Chassis		5
		05-07	Ford F-550 Super Duty Cab & Chassis		5
	3065-P	05-07	Ford F-250 Super Duty		5
		05-07	Ford F-350 Super Duty		5
		05-07	Ford F-350 Super Duty Cab & Chassis		5
		05-07	Ford F-450 Super Duty Cab & Chassis		5
		05-07	Ford F-550 Super Duty Cab & Chassis		5
	3070	09-16	Honda Pilot w/Factory Tow Package		5
		06-14	Honda Ridgeline w/Factory Tow Package		5
	3070-P	09-16	Honda Pilot w/Factory Tow Package		5
		06-14	Honda Ridgeline w/Factory Tow Package		5
T-ONE CONNECTOR					
E7	118300	04-07	Chrysler Town & Country	1	20
		04-07	Dodge Caravan		20
		04-07	Dodge Grand Caravan		20
E10	118301	04-12	Chevrolet Colorado	1	10
		04-12	GMC Canyon		10
		06	Isuzu i-280		10
		07-08	Isuzu i-290		10
		06	Isuzu i-350		10
		07-08	Isuzu i-370		10
E11	118302	06-08	Acura TSX 4 Dr. Sedan	1	10
		03-07	Honda Accord 4 Dr. Sedan		10
E17	118303	04-08	Chrysler Pacifica	1	25
E10	118304	04-10	Toyota Sienna	1	20
E19	118305	03	Ford Windstar (Built After 11/2002)	2	45
E8	118306	03-06	Mitsubishi Outlander	1	25
E7	118307	03-06	KIA Sorento		5
E10	118308	02-06	Toyota Camry 4 Dr. Sedan	1	5
E8	118309	02-05	KIA Sedona	1	25
E1	118311	73-74	Chevrolet Blazer Full Size		5
		75-84	Chevrolet Blazer K5 Full Size		5
		73-84	Chevrolet C10		5
		73-84	Chevrolet C20		5
		73-84	Chevrolet C30		5
		73-84	Chevrolet K10		5
		73-84	Chevrolet K20		5
		77-84	Chevrolet K30		5
		73-84	Chevrolet Suburban C10		5
		73-84	Chevrolet Suburban C20		5
		73-84	Chevrolet Suburban K10		5
		73-84	Chevrolet Suburban K20		5
		75-78	GMC C15		5
		73-74	GMC C15/C1500		5
		79-84	GMC C1500		5
		75-78	GMC C25		5
		67-74	GMC C25/C2500		5
		79-84	GMC C2500		5
		75-78	GMC C35		5
		73-74	GMC C35/C3500		5
		79-84	GMC C3500		5
		73-84	GMC Jimmy Full Size		5
		67-78	GMC K15		5
		79-84	GMC K1500		5
		73-78	GMC K25		5
		79-84	GMC K2500		5
		67-78	GMC K35		5
		79-84	GMC K3500		5
		73-78	GMC Suburban C15		5
		79-84	GMC Suburban C1500		5
		75-78	GMC Suburban C25		5
		79-84	GMC Suburban C2500		5
		73-78	GMC Suburban K15		5
		79-84	GMC Suburban K1500		5

T-ONE CONNECTOR APPLICATION NUMERICAL

T-ONE CONNECTOR APPLICATION NUMERICAL

T-ONE CONNECTOR APPLICATION NUMERICAL

PC	PART NO.	YEARS	MAKE/MODEL	WGT LBS	IN
E1	118311	73-78	GMC Suburban K25		5
		79-84	GMC Suburban K2500		5
E3	118312	87-91	Chevrolet Blazer Full Size		5
		85-86	Chevrolet Blazer K5 Full Size		5
		85-86	Chevrolet C10		5
		85-86	Chevrolet C20		5
		88-91	Chevrolet C2500 Crew Cab		5
		85-86	Chevrolet C30		5
		88-91	Chevrolet C3500 Crew Cab		5
		85-86	Chevrolet K10		5
		85-86	Chevrolet K20		5
		88-91	Chevrolet K2500 Crew Cab		5
		85-86	Chevrolet K30		5
		88-91	Chevrolet K3500 Crew Cab		5
		85-97	Chevrolet S10		5
		85-86	Chevrolet Suburban C10		5
		85-86	Chevrolet Suburban C20		5
		85-86	Chevrolet Suburban K10		5
		85-86	Chevrolet Suburban K20		5
		87-88	Chevrolet Suburban R10		5
		89-91	Chevrolet Suburban R1500		5
		87-88	Chevrolet Suburban R20		5
		89-91	Chevrolet Suburban R2500		5
		87-88	Chevrolet Suburban V10		5
		89-91	Chevrolet Suburban V1500		5
		87-88	Chevrolet Suburban V20		5
		89-91	Chevrolet Suburban V2500		5
		85-86	GMC C1500		5
		85-86	GMC C2500		5
		88-91	GMC C2500 Crew Cab		5
		85-86	GMC C3500		5
		88-91	GMC C3500 Crew Cab		5
		85-91	GMC Jimmy Full Size		5
		85-86	GMC K1500		5
		85-86	GMC K2500		5
		88-91	GMC K2500 Crew Cab		5
		85-86	GMC K3500		5
		88-91	GMC K3500 Crew Cab		5
		85-90	GMC S15		5
		91-97	GMC Sonoma		5
		85-86	GMC Suburban C1500		5
		85-86	GMC Suburban C2500		5
		85-86	GMC Suburban K1500		5
		85-86	GMC Suburban K2500		5
		87-91	GMC Suburban R1500		5
		87-91	GMC Suburban R2500		5
		87-91	GMC Suburban V1500		5
		87-91	GMC Suburban V2500		5
		91	GMC Syclone		5
		96-97	Isuzu Hombre		5
E1	118313	80-86	Ford Bronco		5
		80-83	Ford F-100		5
		80-86	Ford F-150		5
		80-86	Ford F-250		5
		80-86	Ford F-350		5
		83-85	Ford Ranger		5
E4	118314	86-92	Ford Ranger		5
E3	118315	88-99	Chevrolet C1500 Except 88-91 Crew Cab		5
		88-99	Chevrolet C2500 Except 88-91 Crew Cab		5
		88-00	Chevrolet C3500 Except 88-91 Crew Cab		5
		88-99	Chevrolet K1500 Except 88-91 Crew Cab		5
		88-99	Chevrolet K2500 Except 88-91 Crew Cab		5
		88-00	Chevrolet K3500 Except 88-91 Crew Cab		5
		88-99	GMC C1500 Except 88-91 Crew Cab		5
		88-00	GMC C2500 Except 88-91 Crew Cab		5
		88-00	GMC C3500 Except 88-91 Crew Cab		5
		88-99	GMC K1500 Except 88-91 Crew Cab		5
		88-00	GMC K2500 Except 88-91 Crew Cab		5
		88-00	GMC K3500 Except 88-91 Crew Cab		5
E4	118316	87-96	Ford F-150		5
		87-96	Ford F-250		5
		97	Ford F-250 Heavy Duty		5
		87-96	Ford F-350		5
		97	Ford F-350 Heavy Duty		5
E5	118317	86-93	Dodge D150	1	5
		86-93	Dodge D250		5
		86-93	Dodge D350		5

PC	PART NO.	YEARS	MAKE/MODEL	WGT LBS	IN
E5	118317	87-93	Dodge D350 Cab & Chassis	1	5
		87-94	Dodge Dakota		5
		94	Dodge Ram 1500		5
		94	Dodge Ram 2500		5
		94	Dodge Ram 3500		5
		94-02	Dodge Ram 3500, Cab & Chassis		5
		86-93	Dodge Ramcharger		5
		86-93	Dodge W150		5
		86-93	Dodge W250		5
		86-93	Dodge W350		5
		87-93	Dodge W350 Cab & Chassis		5
E3	118319	99-00	Cadillac Escalade		5
		92-94	Chevrolet Blazer Full Size		5
		92-99	Chevrolet Suburban C1500		5
		92-99	Chevrolet Suburban C2500		5
		92-99	Chevrolet Suburban K1500		5
		92-99	Chevrolet Suburban K2500		5
		95-00	Chevrolet Tahoe		5
		92-99	GMC Suburban C1500		5
		92-99	GMC Suburban C2500		5
		92-99	GMC Suburban K1500		5
		92-99	GMC Suburban K2500		5
		92-00	GMC Yukon		5
		99-00	GMC Yukon Denali		5
E6	118323	91-95	Chrysler Town & Country	1	10
		91-95	Dodge Caravan		10
		03-10	Dodge Dakota		10
		91-95	Dodge Grand Caravan		10
		06-09	Mitsubishi Raider		10
		91-95	Plymouth Grand Voyager		10
		91-95	Plymouth Voyager		10
		11	RAM Dakota		10
E9	118325	93-99	Ford Ranger	1	5
		94-08	Mazda B2300		5
		98-01	Mazda B2500		5
		94-08	Mazda B3000		5
		94-08	Mazda B4000		5
E9	118326	92-97	Ford Crown Victoria		20
		94-04	Ford Mustang Except Cobra SVT 99-04		20
		92-97	Mercury Grand Marquis		20
E1	118328	93-94	Dodge Van, B150		5
		95-98	Dodge Van, B1500		5
		93-94	Dodge Van, B250		5
		95-98	Dodge Van, B2500		5
		93-94	Dodge Van, B350		5
		95-98	Dodge Van, B3500		5
E7	118329	95-03	Dodge Dakota	1	5
		95-01	Dodge Ram 1500		5
		95-02	Dodge Ram 2500		5
		95-02	Dodge Ram 3500		5
		95-01	Dodge Ram 4000		5
E11	118330	91-96	Jeep Cherokee	1	20
E5	118331	94-97	Honda Passport		5
		92-97	Isuzu Rodeo		5
E9	118333	96-99	Ford Taurus 4 Dr. Sedan	1	10
		96-99	Mercury Sable Sedan		10
E10	118334	96-00	Chrysler Town & Country	1	20
		96-00	Dodge Caravan		20
		98-03	Dodge Durango		20
		96-00	Dodge Grand Caravan		20
		96-00	Plymouth Grand Voyager		20
		96-00	Plymouth Voyager		20
E8	118335	96-99	Chevrolet Express 1500		20
		96-99	Chevrolet Express 2500		20
		96-99	Chevrolet Express 3500		20
		96-99	GMC Savana 1500		20
		96-99	GMC Savana 2500		20
		96-99	GMC Savana 3500		20
E5	118336	97-03	Acura CL	1	5
		94-01	Acura Integra		5
		01-06	Acura MDX		10
		96-01	Acura RL		5
		96-03	Acura TL		5
		94-02	Honda Accord 4 Dr. Sedan		5
		93-97	Honda Civic Del Sol		5
		97-06	Honda CR-V		10
		03-04	Honda Element		10

T-ONE CONNECTOR APPLICATION NUMERICAL

PC	PART NO.	YEARS	MAKE/MODEL	WGT LBS	IN			
E5	118336	95-04	Honda Odyssey	1	10			
		03-08	Honda Pilot		10			
		01	Honda Prelude		5			
		96-99	Isuzu Oasis		10			
E7	118337†	93-96	Chevrolet Lumina APV	1	20			
		93-96	Oldsmobile Silhouette		20			
		93-96	Pontiac Trans Sport		20			
E4	118338	87-95	Chevrolet G10		10			
		87-95	Chevrolet G20		10			
		87-95	Chevrolet G30		10			
		87-95	GMC G1500		10			
		87-95	GMC G2500		10			
		87-95	GMC G3500		10			
E5	118339	96-99	Acura SLX		5			
		92-02	Isuzu Trooper		5			
E11	118341	96-02	Toyota 4Runner	1	20			
E9	118343	92-94	Ford E-150 Econoline	1	10			
		92-94	Ford E-250 Econoline		10			
		92-94	Ford E-350 Econoline		10			
		01-03	Ford Escape		10			
		01-03	Mazda Tribute		10			
E5	118344	97	Ford Aerostar Extended Body	1	10			
		97	Ford Aerostar Standard Body		10			
		95-02	Ford E-150 Econoline		10			
		95-02	Ford E-250 Econoline		10			
		95-02	Ford E-350 Econoline		10			
		97-99	Ford Escort 4 Dr. Sedan		10			
		98-03	Ford Escort ZX2		10			
		00-03	Ford Excursion		10			
		97-03	Ford Expedition		10			
		01-03	Ford Explorer 2 Dr. Sport		10			
		02-03	Ford Explorer 4 Dr.		10			
		02-03	Ford Explorer Sport Trac		10			
		97-03	Ford F-150 Flareside		10			
		04	Ford F-150 Heritage Flareside		10			
		00-03	Ford F-150 SuperCrew		10			
		00-03	Ford Focus Wagon (Built Before 11/2002)		10			
		00-03	Ford Ranger		10			
		03-04	Lincoln Aviator		10			
		98-03	Lincoln Navigator		10			
		02-03	Mercury Mountaineer		10			
		97-99	Mercury Tracer 4 Dr. Sedan		10			
		E16	118345		92-94	Ford E-150 Econoline	2	45
					92-94	Ford E-250 Econoline		45
92-94	Ford E-350 Econoline			45				
01-03	Ford Escape			45				
95-00	Ford Explorer			45				
01	Ford Explorer 4 Dr.			45				
01-03	Mazda Tribute			45				
97-01	Mercury Mountaineer			45				
E16	118349	94-98	Jeep Grand Cherokee	1	45			
E8	118353	86-94	Nissan D21 (App. starts with 86-1/2)	1	10			
		87-95	Nissan Pathfinder		10			
E7	118354	97-01	Jeep Cherokee	1	20			
E8	118355	97-05	Chevrolet Venture	1	10			
		97-04	Oldsmobile Silhouette		10			
		99-05	Pontiac Montana		10			
		07-09	Pontiac Montana (Canada Only)		10			
		97-98	Pontiac Trans Sport		10			
E5	118356	97	Jeep TJ (Canada Only)	1	10			
		91-97	Jeep Wrangler		10			
E5	118357	96-97	Lexus LX450		5			
		96-97	Toyota Land Cruiser		5			
E8	118358	97-01	Toyota Camry 4 Dr. Sedan	1	5			
E4	118359	98-04	Chevrolet S10		5			
		98-04	GMC Sonoma		5			
		98-00	Isuzu Hombre		5			
E17	118360	98-02	Honda Passport	1	15			
		98-00	Isuzu Amigo		15			
		98-04	Isuzu Rodeo		15			
		01-03	Isuzu Rodeo Sport		15			
E8	118361	97-03	Infiniti QX4	1	20			
		98-01	Nissan Altima		20			
		96-04	Nissan Pathfinder		20			
E10	118362	98	Mercury Villager	1	5			
		98-04	Nissan Frontier		5			
		98	Nissan Quest		5			

PC	PART NO.	YEARS	MAKE/MODEL	WGT LBS	IN
E12	118364	99-04	Chrysler 300M	1	15
		98-02	Chrysler Concorde		15
		98-04	Chrysler Intrepid (Canada Only)		15
		99	Chrysler LHS		15
E5	118365	98-04	Dodge Intrepid	1	5
		98-99	Lexus LX470		5
E19	118366	99-03	Ford Windstar (Built Before 11/2002)	2	45
		00	Toyota Tundra		10
E1	118368	99-00	Dodge Van, Ram 1500		5
		99-00	Dodge Van, Ram 2500		5
		99-00	Dodge Van, Ram 3500		5
E10	118369	99-04	Jeep Grand Cherokee		10
E5	118372	98-04	Chevrolet Tracker	1	5
		96-97	GEO Tracker		5
		99-05	Suzuki Grand Vitara		5
		89-98	Suzuki Sidekick		5
		99-04	Suzuki Vitara		5
		02-06	Suzuki XL-7		5
E17	118373	00-06	Lincoln LS	1	20
E4	118375	00-03	Ford Taurus 4 Dr. Sedan	1	10
		00-03	Mercury Sable Sedan		10
E7	118376	01-03	Chrysler Town & Country	1	15
		01-03	Chrysler Voyager		15
		01-03	Dodge Caravan		15
		01-03	Dodge Grand Caravan		15
E8	118377	00-02	Chevrolet Express 1500	1	10
		00-02	Chevrolet Express 2500		10
		00-02	Chevrolet Express 3500		10
		00-02	GMC Savana 1500		10
		00-02	GMC Savana 2500		10
		00-02	GMC Savana 3500		10
E17	118378	01-02	Toyota Tundra	1	10
E14	118379	89-95	Toyota Pickup Except T-100	1	10
		95-04	Toyota Tacoma (App. starts with 95-1/2)		10
E12	118380	01-06	Mitsubishi Montero Except Montero Sport	1	20
E3	118381	07-08	Chrysler Aspen w/Factory 7-Way		5
		04-08	Chrysler Pacifica w/Factory 7-Way		5
		00-09	Dodge Dakota w/Factory 7-Way		5
		00-08	Dodge Durango w/Factory 7-Way		5
		00-08	Dodge Ram 1500 w/Factory 7-Way		5
		00-09	Dodge Ram 2500 w/Factory 7-Way		5
		00-09	Dodge Ram 3500 w/Factory 7-Way		5
		03-09	Dodge Sprinter 2500 w/Factory 7-Way		5
		03-09	Dodge Sprinter 3500 w/Factory 7-Way		5
		01-03	Dodge Van, Ram 1500		5
		01-03	Dodge Van, Ram 2500		5
		01-03	Dodge Van, Ram 3500		5
		03-09	Freightliner Sprinter 2500 w/Factory 7-Way		5
03-09	Freightliner Sprinter 3500 w/Factory 7-Way	5			
06-10	Jeep Commander w/Factory 7-Way	5			
00-10	Jeep Grand Cherokee w/Factory 7-Way	5			
05-08	Jeep Liberty w/Factory 7-Way	5			
06-09	Mitsubishi Raider w/Factory 7-Way	5			
E10	118383	02-07	Buick Rendezvous	1	20
		01-05	Pontiac Aztek		20
E8	118384	08-12	Buick Enclave w/Factory 7-Way	1	5
		04-07	Buick Rainier w/Factory 7-Way		5
		02-16	Cadillac Escalade		5
		03-15	Cadillac Escalade ESV		5
		02-11	Cadillac Escalade EXT w/Factory 7-Way		5
		02-06	Chevrolet Avalanche 1500 w/Factory 7-Way		5
		02-06	Chevrolet Avalanche 2500 w/Factory 7-Way		5
		07-11	Chevrolet Avalanche w/Factory 7-Way		5
		99-01	Chevrolet Blazer Downsize, w/Factory 7-Way		5
		99-01	Chevrolet Blazer Trailblazer w/Factory 7-Way		5
		04-12	Chevrolet Colorado w/Factory 7-Way		5
		07-17	Chevrolet Silverado 1500		5
		07	Chevrolet Silverado 1500 (Classic), w/Factory 7-Way		5
		07	Chevrolet Silverado 1500 HD (Classic), w/Factory 7-Way		5
01-06	Chevrolet Silverado 1500 HD w/Factory 7-Way	5			
99-06	Chevrolet Silverado 1500 w/Factory 7-Way	5			
07-16	Chevrolet Silverado 2500 HD	5			
07	Chevrolet Silverado 2500 HD (Classic), w/Factory 7-Way	5			
01-06	Chevrolet Silverado 2500 HD w/Factory 7-Way	5			
99-04	Chevrolet Silverado 2500 w/Factory 7-Way	5			
07	Chevrolet Silverado 3500 (Classic), w/Factory 7-Way	5			

† = Available while supplies last.

T-ONE CONNECTOR APPLICATION NUMERICAL

T-ONE CONNECTOR APPLICATION NUMERICAL

PC	PART NO.	YEARS	MAKE/MODEL	WGT LBS	IN
E8	118384	07-16	Chevrolet Silverado 3500 HD	1	5
		01-06	Chevrolet Silverado 3500 w/Factory 7-Way		
		14-15	Chevrolet Suburban		
		00-14	Chevrolet Suburban 1500 w/Amber Turn Signals		
		00-13	Chevrolet Suburban 2500 w/Amber Turn Signals		
		00-11	Chevrolet Tahoe w/Amber Turn Signals		
		02-09	Chevrolet TrailBlazer w/Factory 7-Way		
		09-12	Chevrolet Traverse w/Factory 7-Way		
		09	Chrysler Aspen w/Factory 7-Way		
		09	Dodge Durango w/Factory 7-Way		
		09-10	Dodge Ram 1500 w/Factory 7-Way		
		10	Dodge Ram 2500 w/Factory 7-Way		
		10	Dodge Ram 3500 w/Factory 7-Way		
		07-12	GMC Acadia w/Factory 7-Way		
		04-12	GMC Canyon w/Factory 7-Way		
		02-09	GMC Envoy w/Factory 7-Way		
		99-01	GMC Jimmy Downsize, w/Factory 7-Way		
		07-17	GMC Sierra 1500		
		07	GMC Sierra 1500 (Classic), w/Factory 7-Way		
		07	GMC Sierra 1500 HD (Classic), w/Factory 7-Way		
		01-06	GMC Sierra 1500 HD w/Factory 7-Way		
		99-06	GMC Sierra 1500 w/Factory 7-Way		
		07-16	GMC Sierra 2500 HD		
		07	GMC Sierra 2500 HD (Classic), w/Factory 7-Way		
		11-12	GMC Sierra 2500 HD Denali HD		
		01-06	GMC Sierra 2500 HD w/Factory 7-Way		
		99-04	GMC Sierra 2500 w/Factory 7-Way		
		07	GMC Sierra 3500 (Classic), w/Factory 7-Way		
		07-16	GMC Sierra 3500 HD		
		01-06	GMC Sierra 3500 w/Factory 7-Way		
		00-11	GMC Yukon w/Amber Turn Signals		
		00-11	GMC Yukon XL 1500		
		00-11	GMC Yukon XL 2500		
		03-09	Hummer H2 w/Factory 7-Way		
		06-10	Hummer H3 w/Factory 7-Way		
		09-10	Hummer H3T w/Factory 7-Way		
		04-12	Infiniti QX56 w/Factory 7-Way		
		03-08	Isuzu Ascender w/Factory 7-Way		
		11-15	Jeep Grand Cherokee w/Factory 7-Way		
		09-12	Jeep Liberty w/Factory 7-Way		
		09-11	KIA Borrego w/Factory 7-Way		
		10-11	Lexus GX460 w/Factory 7-Way		
		05-14	Nissan Armada w/Factory 7-Way		
		04	Nissan Pathfinder Armada w/Factory 7-Way		
		04-14	Nissan Titan w/Factory 7-Way		
		99-04	Oldsmobile Bravada w/Factory 7-Way		
		11-17	RAM 1500 w/Factory 7-Way		
		11-17	RAM 2500 w/Factory 7-Way		
		11-17	RAM 3500 w/Factory 7-Way		
		05-09	Saab 9-7X w/Factory 7-Way		
07-09	Saturn Outlook w/Factory 7-Way				
10-11	Toyota 4Runner w/Factory 7-Way				
09-13	Toyota Tacoma w/Factory 7-Way				
10-13	Toyota Tundra w/Factory 7-Way				
E17	118385	04-07	Ford Freestar	2	45
		04-07	Mercury Monterey		
E12	118386	00-02	Toyota Echo	1	20
		03-08	Toyota Matrix		
E13	118387	03	Toyota Corolla	1	15
E12	118388	96-00	Toyota RAV4	1	20
E12	118389	01-05	Toyota RAV4	1	20
E15	118390	07-09	Chrysler Aspen	2	45
		04-09	Dodge Durango		
E8	118391	05-06	Chevrolet Equinox	1	10
		06	Pontiac Torrent		
E5	118392	03-14	Chevrolet Express 1500	1	20
		03-17	Chevrolet Express 2500		
		03-17	Chevrolet Express 3500		
		03-14	GMC Savana 1500		
		03-17	GMC Savana 2500		
		03-17	GMC Savana 3500		
E17	118394	05-06	Jeep Grand Cherokee	1	20
E5	118395	05-07	Ford Five Hundred		10
		05-07	Ford Freestyle		
E10	118396	05-07	Buick Terraza	1	15
		05-08	Chevrolet Uplander		
		09	Chevrolet Uplander (Canada Only)		

PC	PART NO.	YEARS	MAKE/MODEL	WGT LBS	IN
E10	118396	05-06	Pontiac Montana SV6	1	15
		07-09	Pontiac Montana SV6 (Canada Only)		
		05-07	Saturn Relay		
E16	118397	05-09	Hyundai Tucson	1	30
E8	118398	05-10	Chevrolet Cobalt 4 Dr.	1	10
		08	Chevrolet Cobalt Sport 4 Dr.		
		05-10	Chevrolet Cobalt SS 4 Dr.		
		05-06	Pontiac Pursuit 4 Dr. (Canada Only)		
E15	118400	06-08	Honda Ridgeline	1	10
E8	118401	05-10	KIA Sportage 6 Cyl.	1	5
E19	118402	05-08	Dodge Magnum	2	45
E7	118404	05-07	Chrysler 300 Except 300 C	1	10
		08-14	Dodge Challenger		
		06-10	Dodge Charger		
E16	118405	14-15	Mazda 3 4 Dr. Sedan	2	45
		14	Mazda 3 5 Dr. Hatchback		
		03-08	Mazda 6 4 Dr. Sedan		
		04-08	Mazda 6 5 Dr. Hatchback		
		07-12	Mazda CX-7		
		07-09	Toyota Camry 4 Dr. Sedan, Except Hybrid		
		12-17	Toyota Camry Including Hybrid		
		14-16	Toyota Corolla		
		07-14	Toyota FJ Cruiser		
		E14	118406		
05-07	Chrysler 300 C				
E5	118407	05-10	Chevrolet Cobalt 2 Dr.	1	15
		08	Chevrolet Cobalt Sport 2 Dr.		
		05-10	Chevrolet Cobalt SS 2 Dr.		
		06-11	Chevrolet HHR		
		08-10	Chevrolet HHR SS		
E16	118408	07-09	Pontiac G5 2 Dr.	1	15
		07-09	Pontiac G5 GT 2 Dr.		
E7	118409	98-06	Jeep TJ (Canada Only)	1	15
		98-06	Jeep Wrangler	1	15
E19	118410	07-09	Hyundai Entourage	2	45
		06-14	KIA Sedona		
E18	118411	05-14	Volvo XC90	2	20
E16	118412	06-12	Toyota RAV4	1	45
		08-10	Toyota Sequoia		
E10	118413	06-11	Hyundai Azera	1	20
		01-07	Toyota Highlander Except Hybrid		
E12	118414	04-06	Scion xB	1	20
E12	118415	07-12	Hyundai Santa Fe	1	20
		10-13	KIA Forte 4 Dr. Sedan		
E5	118416	07-17	Jeep Wrangler Except w/Right Hand Drive & Limited Edition		10
E5	118417	06-13	Chevrolet Impala		10
E16	118418	02-07	Saturn Vue	1	20
E5	118419	06-11	Buick Lucerne	1	10
E14	118420	09-14	Acura TSX 4 Dr. Sedan	1	15
		08-12	Honda Accord Coupe		
		08-12	Honda Accord Sedan		
		06-15	Honda Civic 4 Dr. Sedan, Except Hybrid & Si		
		07-13	Honda Fit		
		04-13	Mazda 3 4 Dr. Sedan, Except w/Grand Touring LED Taillights		
		04-13	Mazda 3 5 Dr. Hatchback, Except w/Grand Touring LED Taillights		
E13	118421	07	Dodge Nitro	1	15
E14	118422	11-16	Ford Fiesta 4 Dr. Sedan	1	30
		06-12	Ford Fusion		
E11	118423	07-09	Saturn Aura	1	15
E11	118424	07-13	Acura MDX	1	20
E7	118425	07-13	Jeep Grand Cherokee	1	20
E17	118426	05-07	Ford Escape	2	45
		05-06	Mazda Tribute		
E8	118427	07-11	Honda CR-V	1	20
E18	118428	07	Dodge Caliber	2	45
		07-10	Jeep Compass		
		07	Jeep Patriot		
E14	118431	07-10	KIA Rondo	1	15
		11-12	KIA Rondo (Canada Only)		
		10-16	KIA Soul Except w/LED Taillights		
E7	118432	07-09	Chevrolet Equinox	1	10
		07-09	Pontiac Torrent		
		07-09	Suzuki XL-7 w/Factory Tow Package		
E12	118433	07-10	Hyundai Elantra 4 Dr. Sedan	1	10

T-ONE CONNECTOR APPLICATION NUMERICAL

PC	PART NO.	YEARS	MAKE/MODEL	WGT LBS	IN
E12	118433	06-09	Hyundai Sonata	1	10
		09-10	KIA Optima		10
E10	118434	07-09	Saturn Outlook		15
E8	118436	06-07	Honda Accord 2 Dr. Coupe	1	10
E12	118437	06-15	Honda Civic 2 Dr. Coupe, Except Si	1	10
E12	118438	05-10	Honda Odyssey	1	20
E7	118439	08	Chevrolet Malibu Classic LS	1	15
		08	Chevrolet Malibu Classic LT		15
		04-07	Chevrolet Malibu LS 4 Dr. Sedan		15
		04-07	Chevrolet Malibu LT 4 Dr. Sedan		15
		04-07	Chevrolet Malibu Maxx LS		15
		04-07	Chevrolet Malibu Maxx LT		15
		06-07	Chevrolet Malibu SS 4 Dr. Sedan		15
		05-09	Pontiac G6		15
E15	118440	03-07	Cadillac CTS	2	45
		04-07	Cadillac CTS V		45
E11	118441	03-05	Honda Accord 2 Dr. Coupe	1	10
E19	118443	12	Chevrolet Captiva Sport	2	45
		08-09	Saturn Vue		45
E19	118444	07-10	Chrysler Sebring	2	45
		07-10	Chrysler Sebring Convertible		45
E19	118445	08-10	Dodge Avenger	2	45
E7	118447	08-09	Ford Taurus 4 Dr. Sedan		10
		08-09	Mercury Sable Sedan		10
E7	118448	08-09	Ford Taurus X		15
E13	118449	08-16	Toyota Highlander	1	20
E7	118450	08-12	Buick Enclave		10
		08-12	Chevrolet Malibu Except LTZ		10
		09-12	Chevrolet Traverse		10
E11	118451	07-12	GMC Acadia	1	15
E7	118452	07-08	KIA Optima		10
E10	118453	07-09	KIA Amanti	1	10
		11-16	KIA Optima		10
E19	118454	07-16	Volvo S80 Sedan	2	45
E12	118456	06-12	Suzuki Grand Vitara	2	20
		07-11	Suzuki SX4 Crossover		20
E5	118457	08-11	Ford Focus	1	15
E11	118458	03-08	Pontiac Vibe	1	15
E16	118459	09-13	Toyota Corolla	2	45
E16	118460	09-10	Pontiac Vibe	2	45
		11-13	Scion xB		45
		09-13	Toyota Matrix		45
E12	118461	06-07	Subaru B9 Tribeca	1	10
		98-08	Subaru Forester		10
		05-07	Subaru Legacy Wagon		10
		96-99	Subaru Legacy Wagon, Outback		10
		00-09	Subaru Outback Wagon, Except Sport		10
		08-14	Subaru Tribeca		10
E19	118462	01-10	Chrysler PT Cruiser	2	45
		05-10	Chrysler PT Cruiser Convertible		45
E15	118463	08-10	Volvo V70 Wagon, Except w/Optional Power Operated Tailgate	2	45
E17	118464	08-11	Subaru Impreza 4 Dr. Sedan	2	45
E14	118465	07-11	Honda Element	1	45
E15	118466	08-13	Cadillac CTS 4 Dr. Sedan	1	15
E11	118467	16	Subaru Crosstrek Except Hybrid	1	15
		09-17	Subaru Forester		15
		10-17	Subaru Outback Wagon, Except Sport		15
		13-15	Subaru XV Crosstrek Except Hybrid		15
E18	118468	08-10	Scion xB	2	45
E16	118469	04-09	Nissan Quest	1	45
E17	118470	08-13	Nissan Altima Coupe	2	45
		07-15	Nissan Altima Sedan		45
		04-14	Nissan Maxima		45
		07-12	Nissan Sentra		45
E18	118471	11-13	Ford Fiesta 5 Dr. Hatchback	2	45
		09-12	Lincoln MKS		45
E8	118472	09-16	Ford Flex	1	15
E11	118473	09-12	Hyundai Elantra Touring 5 Dr.	1	15
		01-06	Hyundai Santa Fe		15
E18	118474	09	Dodge Journey	2	45
E12	118475	08-11	Suzuki SX4 Sport Sedan	1	20
E15	118476	09-11	Hyundai Genesis 4 Dr. Sedan	1	15
E17	118478	04-06	Lexus RX330	2	45
		07-12	Lexus RX350		45
E7	118479	05-09	Buick LaCrosse	1	10
E15	118480	07-08	Infiniti G35 4 Dr. Sedan	2	45
		09-13	Infiniti G37 4 Dr. Sedan		45

PC	PART NO.	YEARS	MAKE/MODEL	WGT LBS	IN
E15	118480	14-16	Nissan Rogue	2	45
		08-13	Nissan Rogue Except Krom		45
		14	Nissan Rogue Select		45
E17	118482	14-17	Mitsubishi Outlander Except Outlander Sport	2	45
		11-12	Toyota Avalon		45
		10-11	Toyota Camry 4 Dr. Sedan, Except Hybrid		45
		07-11	Toyota Camry Hybrid 4 Dr. Sedan		45
		09-16	Toyota Venza		45
E19	118483	09-13	Mazda 6 4 Dr. Sedan	2	45
E13	118484	07-10	Scion tC	1	15
E13	118485	04-06	Chevrolet Aveo 4 Dr. Sedan	1	15
		04-11	Chevrolet Aveo 5 Dr. Hatchback		15
		09	Pontiac G3 5 Dr.		15
E17	118486	10-11	Chevrolet Camaro	1	15
E16	118487	10-17	Ford Mustang	2	45
E16	118488	07-11	Lexus ES350	2	45
E10	118489	04-08	Acura TL	1	10
E7	118490	09-12	Volkswagen Routan	1	20
E15	118491	09-11	Honda Pilot	1	20
		09-14	Honda Ridgeline		10
E15	118492	09-12	Nissan Cube	1	45
E16	118494	10-17	Chevrolet Equinox	2	45
		10-17	GMC Terrain		45
E8	118495	10	Dodge Journey	1	10
E13	118496	08-12	Toyota Hilux	1	10
		93-98	Toyota T100		10
		05-15	Toyota Tacoma		10
E18	118497	10-16	Buick LaCrosse	2	45
E18	118498	11-17	Toyota Sienna SE	2	45
E11	118500	07-12	Acura RDX	1	15
		10-11	Honda Accord Crosstour		15
		12	Honda Crosstour		15
E18	118501	10-17	Hyundai Tucson	1	30
E17	118502	07-09	Lincoln MKZ	2	45
		06	Lincoln Zephyr		45
		06-11	Mercury Milan		45
E13	118503	10-13	Acura ZDX	1	30
E18	118504	11-13	Buick Regal	2	45
E16	118505	04-11	Toyota Prius	1	25
		12	Toyota Prius 4 Dr. Sedan, Except w/Plug-In Model		25
E23	118506	11-13	KIA Sorento Base I4	2	45
		11-13	KIA Sorento EX I4		45
		11-13	KIA Sorento EX V6, Except w/Factory Tow Package		45
		11-13	KIA Sorento LX I4		45
		11-13	KIA Sorento LX V6		45
E18	118507	10-14	Lincoln MKT	2	45
E19	118508	11-15	Chevrolet Cruze	2	45
		16	Chevrolet Cruze Limited Only (Old Body Style)		45
E24	118509	04-10	Volkswagen Touareg	2	45
E17	118510	10-12	Lexus HS250h Hybrid	1	20
E14	118511	10-14	Subaru Legacy Sedan	2	45
E5	118512	00-05	Chevrolet Impala	1	25
E12	118514	07-11	Chevrolet Aveo 4 Dr. Sedan	1	25
E21	118515	11-14	Ford Edge	2	45
E12	118516	04-11	Mitsubishi Endeavor	1	30
E18	118517	07-11	Toyota Yaris 4 Dr. Sedan	2	45
E18	118518	07-13	Mitsubishi Outlander Except Outlander Sport	1	45
E23	118519	11-15	Lincoln MKX	2	45
E17	118520	11-14	Mazda 2	2	45
		06-16	Mazda 5		45
		07-15	Mazda CX-9		45
E17	118521	11-16	Honda Odyssey	1	30
E16	118522	10-12	Hyundai Genesis 2 Dr. Coupe	2	45
E20	118523	10-14	Volvo XC60	2	45
E20	118524	02-07	Jeep Liberty	2	45
E14	118525	05-16	Nissan Frontier	1	30
		05-07	Nissan Pathfinder		30
		08-12	Nissan Pathfinder Except w/Factory 4-Flat		30
		05-15	Nissan Xterra		30
		09-12	Suzuki Equator		30
E25	118526	11-16	KIA Sportage	2	45
E17	118528	11-16	Nissan JUKE	2	45
E22	118530	07-10	Volkswagen Passat Wagon	2	45
E16	118532	13-14	Hyundai Elantra 2 Dr. Coupe	2	45
		11-13	Hyundai Elantra 4 Dr. Sedan		45
E17	118533	11-12	Honda CR-Z	2	45
E18	118534	11-16	Chrysler Town & Country	2	45

T-ONE CONNECTOR APPLICATION NUMERICAL

PC	PART NO.	YEARS	MAKE/MODEL	WGT LBS	IN
E18	118534	11-17	Dodge Grand Caravan	2	45
		12-15	RAM C/V Tradesman		45
E16	118535	06-11	Cadillac DTS	2	45
E17	118536	11-16	Dodge Journey w/LED Taillights	2	45
E19	118537	09-14	Acura TL	2	45
E16	118538	12-17	Mitsubishi Lancer 4 Dr. Sedan, Except Evolution, Ralliart & w/Dual Exhaust	2	45
		10-14	Mitsubishi Lancer 5 Dr. Hatchback, Except Ralliart & w/Dual Exhaust		45
		11-16	Mitsubishi Outlander Sport		45
		11-12	Mitsubishi RVR (Canada Only)		45
E20	118539	11-17	Jeep Compass	2	45
E11	118540	11-17	Ford Explorer	1	5
E21	118543	10-12	Lincoln MKZ	2	45
E17	118545	07-12	Nissan Versa 5 Dr. Hatchback	2	45
E20	118546	12-16	FIAT 500	2	45
E19	118547	11-13	Nissan Quest	1	45
E16	118548	12-16	Ford Focus Sedan	2	45
E18	118549	13-14	Ford Focus 5 Dr. Hatchback	2	45
		12-14	Ford Focus 5 Dr. Hatchback, Except ST w/Center Exhaust		45
E18	118550	11	Chrysler 200 4 Dr. Sedan	2	45
		11	Chrysler 200 Convertible		45
		11	Dodge Avenger		45
E17	118551	08-14	Ford E-150 Econoline	2	45
		08-14	Ford E-250 Econoline		45
		08-14	Ford E-350 Econoline Super Duty		45
		07-10	Ford Edge		45
		08-12	Ford Escape		45
		07-10	Lincoln MKX		45
		08-11	Mazda Tribute		45
		05-11	Mercury Mariner		45
E18	118552	08-10	Chrysler Town & Country	2	45
		08-12	Dodge Caliber		45
		11-13	Dodge Durango		45
		08-10	Dodge Grand Caravan		45
		08-17	Jeep Patriot		45
E17	118553	12-16	Nissan NV1500	2	45
		12-16	Nissan NV2500		45
		12-16	Nissan NV3500		45
E19	118554	07-11	Dodge Nitro	2	45
		08-12	Jeep Liberty		45
E16	118556	12-13	Chevrolet Camaro	1	30
E16	118557	10	Hyundai Sonata	2	45
		11-14	Hyundai Sonata Except Hybrid		45
E25	118558	12-15	Honda Pilot	1	30
E16	118559	12-16	Hyundai Accent 4 Dr. Sedan	2	45
E19	118560	11-14	Dodge Charger	1	25
E17	118561	12-16	Honda CR-V	1	45
E25	118562	06-10	Volkswagen Passat 4 Dr. Sedan	2	45
E19	118563	13-16	Mazda CX-5	2	45
E17	118564	12-16	Buick Verano	2	45
E16	118565	12	Chevrolet Orlando (Canada Only)	2	45
E18	118566	13-16	Ford Escape	2	45
E14	118567	12-16	Dodge Journey Except w/LED Taillights	2	45
E16	118568	13-16	Dodge Dart	1	25
E14	118569	13-17	Acura RDX	1	15
E16	118570	12-16	KIA Rio 4 Dr. Sedan	2	45
		12-16	KIA Rio 5 Dr. Hatchback		45
E18	118571	13-16	Hyundai Santa Fe Sport (5 Passenger)	2	45
E27	118572	11-16	Volkswagen Jetta 4 Dr. Sedan	2	45
E19	118573	12-16	Subaru Impreza 5 Dr. Wagon, Except WRX STI	2	45
E16	118574	13-17	Ford Fusion	2	45
E19	118575	13-15	Chevrolet Spark	2	45
E16	118576	13	Chevrolet Malibu Except LTZ & Canada Models	2	45
E17	118577	12-14	Chrysler 200 4 Dr. Sedan	2	45
		12-14	Chrysler 200 Convertible		45
		12-14	Dodge Avenger		45
E16	118578	13-16	Toyota Avalon	2	45
		13-17	Toyota RAV4		45
E15	118580	13-14	Cadillac ATS	1	25
E15	118581	12-16	Subaru Impreza 4 Dr. Sedan, Except WRX & WRX STI	1	45
E16	118582	13-16	Nissan Sentra	2	45
		14	Nissan Versa Note		45
E16	118583	15-17	KIA Sorento EX 14	2	45
		14-17	KIA Sorento LX 14		45
E26	118585	10-13	Ford Transit Connect	2	45
E15	118586	13-15	Honda Accord Coupe, w/LED Taillights	2	45

PC	PART NO.	YEARS	MAKE/MODEL	WGT LBS	IN
E15	118586	13-15	Honda Accord Sedan, w/LED Taillights	2	45
E17	118587	14-17	Mazda 6 4 Dr. Sedan	2	45
E16	118588	13-16	Buick Encore	2	45
E14	118590	14	Chevrolet Impala Except Impala Limited	1	45
E17	118591	13-17	Lincoln MKZ	2	45
E17	118592	13-16	Lexus ES300h Hybrid	2	45
		13-17	Lexus ES350		45
E16	118593	09-12	Infiniti FX35	2	45
		13	Infiniti FX37		45
		09-13	Infiniti FX50		45
E15	118594	14-17	KIA Forte 4 Dr. Sedan	2	45
E15	118595	12-16	Hyundai Azera	2	45
E16	118596	13-15	Honda Accord Coupe, Except w/LED Taillights	2	45
		13-15	Honda Accord Sedan, Except w/LED Taillights		45
E17	118597	15-16	Chevrolet City Express	1	45
		13-16	Nissan NV200		45
E17	118598	13-14	Lexus GS350	2	45
		13	Lexus GS350 F Sport		45
		13	Lexus GS450h		45
E15	118599	10-16	Ford Taurus 4 Dr. Sedan	2	45
		13-16	Lincoln MKS		45
E16	118600	11-14	Chrysler 300	1	25
		11-14	Chrysler 300 C		25
E17	118602	16	Chevrolet Malibu Limited LTZ, Except Canada Models (Old Body Style)	2	45
		13-15	Chevrolet Malibu LTZ Except Canada Models		45
E18	118604	13	Chevrolet Malibu (Canada Only), Except LTZ	2	45
		14-15	Chevrolet Malibu Except LTZ		45
		16	Chevrolet Malibu Limited, Except LTZ (Old Body Style)		45
E18	118605	14-17	Jeep Cherokee	2	45
E15	118608	12-13	Scion xD	2	45
E16	118609	09-13	Lexus IS250	2	45
		09-14	Lexus IS350		45
E13	118610	12-17	Toyota Prius V	2	45
E15	118611	14-15	FIAT 500L	1	25
E14	118613	14-16	Ford Transit Connect	1	45
E18	118615	14	Scion tC	2	45
E15	118616	14	KIA Cadenza	2	45
E16	118617	14-17	Dodge Durango	2	45
E18	118618	14-16	RAM ProMaster 1500 All Models	2	45
		14-16	RAM ProMaster 2500 All Models		45
		14-16	RAM ProMaster 3500 All Models		45
E1	118624	12-14	Land Rover Range Rover Evoque	2	10
E16	118625	11-14	Nissan Leaf	2	45
E16	118626	14-16	Acura RLX	2	45
E18	118627	13-17	Acura ILX	2	45
E11	118628	14-17	Acura MDX		20
E16	118629	14	Scion FR-S	2	45
E17	118637	10-16	KIA Soul Except w/LED Taillights	2	45
		10-16	KIA Soul w/LED Taillights		45
E15	118638	15-16	Chrysler 200 4 Dr. Sedan	2	45
E18	118639	14-17	Buick Regal	2	45
E19	118640	12-15	Chevrolet Sonic 4 Dr. Sedan	1	45
		12-16	Chevrolet Sonic 5 Dr. Hatchback		45
E15	118641	14-16	Ford Fiesta 5 Dr. Hatchback	1	45
E11	118642	14-15	Honda Crosstour	2	15
E16	118643	15-17	Ford Transit-150	3	45
		15-17	Ford Transit-250		45
E15	118644	15-17	Hyundai Sonata Except Hybrid	1	45
E15	118645	14-17	Cadillac CTS 4 Dr. Sedan	2	45
E20	118646	15-16	Volkswagen Golf Except GTI & Sportwagen Models	2	45
E16	118647	15-16	Volvo V60 (App. starts with 2015-1/2)	2	45
E16	118648	15-17	Toyota Sienna Except SE	2	45
E19	118649	14-16	Mercedes-Benz Sprinter 2500	2	45
		14-16	Mercedes-Benz Sprinter 3500		45
E17	118650	07-09	Dodge Sprinter 2500	2	45
		07-09	Dodge Sprinter 3500		45
		07-13	Freightliner Sprinter 2500		45
		07-13	Freightliner Sprinter 3500		45
		07-09	Mercedes-Benz Sprinter		45
		10-13	Mercedes-Benz Sprinter 2500		45
		10-13	Mercedes-Benz Sprinter 3500		45
E26	118651	15-16	Jeep Renegade	2	45
E17	118652	15-17	Lexus NX200t	2	45
		15	Lexus NX300h		45
E15	118653	09-14	Nissan Murano Except CrossCabriolet	1	20
E16	118654	12-16	Ford Ranger	2	45

TOW HARNESS APPLICATION NUMERICAL

PC	PART NO.	YEARS	MAKE/MODEL	WGT LBS	IN
E15	118655	15-16	Dodge Charger		30
E16	118656	15-16	Dodge Challenger	1	30
E15	118658	15-16	Chrysler 300		20
E16	118659	13-14	Chevrolet Trax	2	45
E15	118660	15-16	Nissan Murano Except CrossCabriolet	1	20
E16	118661	15-17	Toyota Yaris	1	45
E14	118663	11-15	Hyundai Sonata Hybrid	1	45
E22	118667	05-10	Volkswagen Jetta 4 Dr. Sedan	2	45
E18	118668	11-17	Volkswagen Touareg	2	45
E16	118669	15-16	Ford Edge Except Sport & Titanium Models	2	45
E20	118670	14-15	Infiniti QX60	1	30
		13-16	Nissan Pathfinder		30
E15	118671	15-17	Subaru Legacy	2	45
E15	118672	14-17	Infiniti Q50	2	45
E14	118673	16-17	Honda HR-V	2	
E18	118674	15-16	Ford Focus 5 Dr. Hatchback	2	45
E20	118675	12-16	Volkswagen Tiguan	2	45
E15	118676	16-17	Nissan Maxima	2	45
E13	118677	15-16	Ford Edge Titanium and Sport Models Only	2	45
E15	118678	16	Hyundai Elantra 4 Dr. Limited Models Only	2	45
E18	118679	16	Honda Pilot		20
E13	118680	12-16	Toyota Prius C		25
E1	118681	14-16	Land Rover Range Rover Sport		10
		15	Land Rover Range Rover w/Factory Tow Package		10
E18	118682	16	Lincoln MKX	2	45
E14	118683	16-17	Volvo XC90	1	20
E16	118684	16-17	Honda Accord Sedan	2	45
E21	118685	16-17	Toyota Tacoma	2	45
E16	118687	15-16	Land Rover Discovery Sport	2	45
E17	118688	12-15	Volkswagen Beetle	2	45
E17	118689	16-17	Chevrolet Malibu (New Body Style)	2	45
E17	118690	16-17	Chevrolet Camaro	2	45
E15	118692	17	Hyundai Elantra 4 Dr. Except Limited Models	2	45
E24	118693	16	FIAT 500X	2	45
E18	118694	16-17	Chevrolet Spark	2	45
E17	118695	16	Honda Accord Coupe	2	45
E14	118696	16	Chevrolet Cruze (New Body Style)	2	45
E17	118698	17	KIA Sportage	2	45
E17	118701	16-17	Toyota Prius	2	45
E15	118711	17	Hyundai Elantra 4 Dr. Limited Models	2	45
E15	118712	17	Chrysler Pacifica Except LX & Touring	2	45
E23	118713	15-16	BMW 320i	2	45
		15-16	BMW 320i xDrive		45
		15-16	BMW 328d		45
		15-16	BMW 328d xDrive		45
		15-16	BMW 328i		45
		15-16	BMW 328i GT xDrive		45
		15-16	BMW 328i xDrive		45
		16	BMW 330e		45
		16	BMW 330i		45
		15	BMW 335i		45
		15-16	BMW 335i GT xDrive		45
		15	BMW 335i xDrive		45
		16	BMW 340i		45
		16	BMW 340i xDrive		45
E16	118714	13-16	Volkswagen CC	2	45
E17	118715	17	Ford Escape	2	45
E23	118717	15-16	BMW X1	2	45
E14	118718	16-17	Mazda CX-3	2	45
E18	118719	15-17	RAM ProMaster City	2	45
E20	118721	16-17	Volkswagen Passat	2	45
E18	118722	15-17	Ford Transit-350	3	45
E18	118723	17	Chrysler Pacifica Except Touring L, Touring L Plus & Limited	2	45
E19	118724	16	Honda Civic Coupe	2	45
E5	118725	16	Buick Envision		15
E17	118726	17	Chevrolet Volt	2	45
E15	118728	16	Scion iA	3	45
		17	Toyota Yaris iA		45
E17	118730	16-17	Volkswagen Golf SportWagen	2	45
E15	118731	16	Nissan Altima Sedan	2	45
TOW HARNESS					
E1	118240	96-03	Chevrolet Express 1500 w/Factory Tow Package		5
		96-03	Chevrolet Express 2500 w/Factory Tow Package		5
		96-03	Chevrolet Express 3500 w/Factory Tow Package		5
		96-03	GMC Savana 1500 w/Factory Tow Package		5
		96-03	GMC Savana 2500 w/Factory Tow Package		5
		96-03	GMC Savana 3500 w/Factory Tow Package		5

PC	PART NO.	YEARS	MAKE/MODEL	WGT LBS	IN
E2	118241	95-01	Ford Explorer w/Factory Tow Package		5
		98-99	Ford Ranger w/Factory Tow Package		5
		98-01	Mazda B2500 w/Factory Tow Package		5
		98-01	Mazda B3000 w/Factory Tow Package		5
		98-01	Mazda B4000 w/Factory Tow Package		5
		97-01	Mercury Mountaineer w/Factory Tow Package		5
E19	118242	04	Ford F-150 Heritage w/Factory 4-Flat	1	5
		97-03	Ford F-150 w/Factory 4-Flat		5
		97-99	Ford F-250 Styleside, w/Factory 4-Flat		5
E15	118243	99-01	Ford F-250 Super Duty w/Factory 4-Flat	1	5
		99-01	Ford F-350 Super Duty w/Factory 4-Flat		5
		99-01	Ford F-450 Super Duty w/Factory 4-Flat		5
		99-01	Ford F-550 Super Duty w/Factory 4-Flat		5
E1	118244	00-04	Nissan Xterra w/Factory Tow Package		5
E3	118245	01-07	Lexus LX470		10
		08-11	Lexus LX570		10
		01-03	Lexus RX300		10
		01-02	Toyota 4Runner		10
		01-03	Toyota Highlander		10
		01-02	Toyota Land Cruiser		10
E1	118246	01-02	Toyota Sequoia		5
E19	118247	04	Ford F-150 w/Factory 4-Flat	1	5
E10	118248	04-07	Toyota Highlander	1	20
E12	118249	07-12	Mazda CX-7 w/Factory Tow Package	1	5
E1	118251	08-12	Ford Escape Except Vehicles w/Back Up Sensors	1	5
		08-11	Mazda Tribute		5
		08-11	Mercury Mariner		5
E3	118252	10-15	Lexus RX350 w/Factory Tow Package		5
		10-12	Lexus RX450h Hybrid, w/Factory Tow Package		5
E22	118253	09-11	Honda Pilot	1	20
		09-14	Honda Ridgeline		10
E13	118255	10-17	Lexus RX350	1	20
		10-12	Lexus RX450h Hybrid		20
E14	118258	07-12	Hyundai Santa Fe w/Factory Tow Package		25
E3	118259	10-16	Cadillac SRX w/Factory Tow Package		5
E3	118260	09-12	Ford E-150 Econoline w/Factory 4-Flat (Prepped Class I Towing Package)		10
		09-12	Ford E-250 Econoline w/Factory 4-Flat (Prepped Class I Towing Package)		10
		09-12	Ford E-350 Econoline Super Duty w/Factory 4-Flat (Prepped Class I Towing Package)		10
E14	118261	09-12	Ford E-150 Econoline w/Factory 7-Way (Prepped Class II Towing Package)	1	10
		09-12	Ford E-250 Econoline w/Factory 7-Way (Prepped Class II Towing Package)		10
		09-12	Ford E-350 Econoline Super Duty w/Factory 7-Way (Prepped Class II Towing Package)		10
E12	118262	10-14	Lexus GX460	1	10
		10-11	Toyota 4Runner		10
E3	118263	05-16	Nissan Frontier w/Factory Tow Package		5
		05-07	Nissan Pathfinder		5
		05-15	Nissan Xterra w/Factory Tow Package		5
		09-12	Suzuki Equator w/Factory Tow Package		5
E1	118264	10-17	Chevrolet Equinox w/Factory Tow Package		15
		10-17	GMC Terrain w/Factory Tow Package		15
E30	118265	12-15	Honda Pilot	2	30
E21	118266	05-16	Nissan Frontier	1	30
		05-07	Nissan Pathfinder		30
		08-12	Nissan Pathfinder Except w/Factory 4-Flat		30
		05-15	Nissan Xterra		30
		09-12	Suzuki Equator		30
E9	118267	05-16	Nissan Frontier w/Factory Tow Package	1	5
		05-07	Nissan Pathfinder		5
		08-12	Nissan Pathfinder Except w/Factory 4-Flat		5
		05-15	Nissan Xterra w/Factory Tow Package		5
		09-12	Suzuki Equator w/Factory Tow Package		5
E13	118269	13-17	Hyundai Santa Fe (6/7 Passenger)	1	20
		14-16	Hyundai Santa Fe Sport (5 Passenger) w/Factory Tow Package		20
		13-17	Hyundai Santa Fe Sport w/Factory Tow Package (5 Passenger)		20
		07-12	Hyundai Veracruz		20
		14-17	KIA Sorento EX V6		20
		11-13	KIA Sorento EX V6, w/Factory Tow Package		20
		14-17	KIA Sorento Limited V6		20
		11-17	KIA Sorento LX V6		20
		11-13	KIA Sorento LX V6 w/Factory Tow Package		20
		11-17	KIA Sorento SX V6		20
		07-09	KIA Sorento w/Factory Tow Package		20

TOW HARNESS APPLICATION NUMERICAL

PC	PART NO.	YEARS	MAKE/MODEL	WGT LBS	IN
E10	118270	13-17	Buick Enclave		20
		13-17	Chevrolet Traverse		20
		13-16	GMC Acadia		20
E16	118271	13-17	Buick Enclave	1	20
		13-17	Chevrolet Traverse		20
		13-16	GMC Acadia		20
E15	118272	11-17	Ford Explorer	1	20
E23	118273	14-15	Infiniti QX60	2	30
		13-16	Nissan Pathfinder		30
E19	118274	16	Honda Pilot	2	20
E8	118275	14-15	Land Rover Range Rover Sport	1	20
		15	Land Rover Range Rover w/Factory Tow Package		20
E9	118276	17	Cadillac XT5	1	10
		17	GMC Acadia		10
E12	118277	16-17	Mitsubishi Outlander Except Sport	1	25
E9	118278	16	Mazda CX-9 w/Factory Tow Package	1	25
E3	118720	17	Cadillac XT5		10
		17	GMC Acadia		10
	20119	08-12	Buick Enclave w/Factory 7-Way	2	10
		04-07	Buick Rainier w/Factory 7-Way		10
		03-15	Cadillac Escalade ESV w/Factory 7-Way		10
		02-11	Cadillac Escalade EXT w/Factory 7-Way		10
		02-16	Cadillac Escalade w/Factory 7-Way		10
		02-06	Chevrolet Avalanche 1500 w/Factory 7-Way		10
		02-06	Chevrolet Avalanche 2500 w/Factory 7-Way		10
		07-11	Chevrolet Avalanche w/Factory 7-Way		10
		99-01	Chevrolet Blazer Downsize, w/Factory 7-Way		10
		99-01	Chevrolet Blazer Trailblazer w/Factory 7-Way		10
		04-12	Chevrolet Colorado w/Factory 7-Way		10
		07	Chevrolet Silverado 1500 (Classic), w/Factory 7-Way		10
		07	Chevrolet Silverado 1500 HD (Classic), w/Factory 7-Way		10
		01-06	Chevrolet Silverado 1500 HD w/Factory 7-Way		10
		99-17	Chevrolet Silverado 1500 w/Factory 7-Way		10
		07	Chevrolet Silverado 2500 HD (Classic), w/Factory 7-Way		10
		01-16	Chevrolet Silverado 2500 HD w/Factory 7-Way		10
		99-04	Chevrolet Silverado 2500 w/Factory 7-Way		10
		07	Chevrolet Silverado 3500 (Classic), w/Factory 7-Way		10
		07-16	Chevrolet Silverado 3500 HD w/Factory 7-Way		10
		01-06	Chevrolet Silverado 3500 w/Factory 7-Way		10
		00-14	Chevrolet Suburban 1500 w/Amber Turn Signals, w/Factory 7-Way		10
		00-13	Chevrolet Suburban 2500 w/Amber Turn Signals, w/Factory 7-Way		10
		00-11	Chevrolet Tahoe w/Amber Turn Signals, w/Factory 7-Way		10
		02-09	Chevrolet TrailBlazer w/Factory 7-Way		10
		09-12	Chevrolet Traverse w/Factory 7-Way		10
		09	Chrysler Aspen w/Factory 7-Way		10
		09	Dodge Durango w/Factory 7-Way		10
		09-10	Dodge Ram 1500 w/Factory 7-Way		10
		10	Dodge Ram 2500 w/Factory 7-Way		10
		10	Dodge Ram 3500 w/Factory 7-Way		10
		97-09	Ford E-150 Econoline w/Factory 7-Way		10
		97-09	Ford E-250 Econoline w/Factory 7-Way		10
		97-09	Ford E-350 Econoline w/Factory 7-Way		10
		00-05	Ford Excursion w/Factory 7-Way		10
		97-15	Ford Expedition w/Factory 7-Way		10
		00-03	Ford Explorer 2 Dr. Sport, w/Factory 7-Way		10
		00-10	Ford Explorer 4 Dr., w/Factory 7-Way		10
		07-10	Ford Explorer Sport Trac w/Factory 7-Way		10
		11-17	Ford Explorer w/Factory 7-Way		10
		97-17	Ford F-150 Flareside, w/Factory 7-Way		10
		04	Ford F-150 Heritage Flareside, w/Factory 7-Way		10
		04	Ford F-150 Heritage Styleside, w/Factory 7-Way		10
		97-17	Ford F-150 Styleside, w/Factory 7-Way		10
		00-17	Ford F-150 SuperCrew, w/Factory 7-Way		10
		97-99	Ford F-250 Styleside, w/Factory 7-Way		10
		99-16	Ford F-250 Super Duty w/Factory 7-Way		10
		99-16	Ford F-350 Super Duty w/Factory 7-Way		10
		99-15	Ford F-450 Super Duty w/Factory 7-Way		10
		99-11	Ford F-550 Super Duty w/Factory 7-Way		10
		09-16	Ford Flex w/Factory 7-Way		10
		00-11	Ford Ranger w/Factory 7-Way		10
		07-12	GMC Acadia w/Factory 7-Way		10
		04-12	GMC Canyon w/Factory 7-Way		10
		02-09	GMC Envoy w/Factory 7-Way		10
		99-01	GMC Jimmy Downsize, w/Factory 7-Way		10
		07	GMC Sierra 1500 (Classic), w/Factory 7-Way		10

PC	PART NO.	YEARS	MAKE/MODEL	WGT LBS	IN
	20119	07	GMC Sierra 1500 HD (Classic), w/Factory 7-Way	2	10
		01-06	GMC Sierra 1500 HD w/Factory 7-Way		10
		99-17	GMC Sierra 1500 w/Factory 7-Way		10
		07	GMC Sierra 2500 HD (Classic), w/Factory 7-Way		10
		11-12	GMC Sierra 2500 HD Denali HD, w/Factory 7-Way		10
		01-16	GMC Sierra 2500 HD w/Factory 7-Way		10
		99-04	GMC Sierra 2500 w/Factory 7-Way		10
		07	GMC Sierra 3500 (Classic), w/Factory 7-Way		10
		07-16	GMC Sierra 3500 HD w/Factory 7-Way		10
		01-06	GMC Sierra 3500 w/Factory 7-Way		10
		01-16	GMC Yukon Denali w/Amber Turn Signals, w/Factory 7-Way		10
		00-16	GMC Yukon w/Amber Turn Signals, w/Factory 7-Way		10
		01-16	GMC Yukon XL 1500 Denali w/Factory 7-Way		10
		00-11	GMC Yukon XL 1500 w/Factory 7-Way		10
		00-13	GMC Yukon XL 2500 w/Factory 7-Way		10
		03-09	Hummer H2 w/Factory 7-Way		10
		06-10	Hummer H3 w/Factory 7-Way		10
		09-10	Hummer H3T w/Factory 7-Way		10
		04-12	Infiniti QX56 w/Factory 7-Way		10
		03-08	Isuzu Ascender w/Factory 7-Way		10
		11-15	Jeep Grand Cherokee w/Factory 7-Way		10
		09-12	Jeep Liberty w/Factory 7-Way		10
		09-11	KIA Borrego w/Factory 7-Way		10
		10-11	Lexus GX460 w/Factory 7-Way		10
		03-05	Lincoln Aviator w/Factory 7-Way		10
		06-08	Lincoln Mark LT w/Factory 7-Way		10
		10-12	Lincoln MKT w/Factory 7-Way		10
		98-11	Lincoln Navigator w/Factory 7-Way		10
		00-10	Mercury Mountaineer w/Factory 7-Way		10
		05-14	Nissan Armada w/Factory 7-Way		10
		04	Nissan Pathfinder Armada w/Factory 7-Way		10
		04-14	Nissan Titan w/Factory 7-Way		10
		99-04	Oldsmobile Bravada w/Factory 7-Way		10
		11-17	RAM 1500 w/Factory 7-Way		10
		11-17	RAM 2500 w/Factory 7-Way		10
		11-17	RAM 3500 w/Factory 7-Way		10
		05-09	Saab 9-7X w/Factory 7-Way		10
		07-09	Saturn Outlook w/Factory 7-Way		10
		10-11	Toyota 4Runner w/Factory 7-Way		10
		09-12	Toyota Tacoma w/Factory 7-Way		10
		10-13	Toyota Tundra w/Factory 7-Way		10
	20135	07-08	Chrysler Aspen w/Factory 7-Way	1	10
		04-08	Chrysler Pacifica w/Factory 7-Way		10
		00-09	Dodge Dakota w/Factory 7-Way		10
		00-08	Dodge Durango w/Factory 7-Way		10
		00-08	Dodge Ram 1500 w/Factory 7-Way		10
		00-09	Dodge Ram 2500 w/Factory 7-Way		10
		00-09	Dodge Ram 3500 w/Factory 7-Way		10
		03-09	Dodge Sprinter 2500 w/Factory 7-Way		10
		03-09	Dodge Sprinter 3500 w/Factory 7-Way		10
		01-03	Dodge Van, Ram 1500 w/Factory 7-Way		10
		01-03	Dodge Van, Ram 2500 w/Factory 7-Way		10
		01-03	Dodge Van, Ram 3500 w/Factory 7-Way		10
		03-09	Freightliner Sprinter 2500 w/Factory 7-Way		10
		03-09	Freightliner Sprinter 3500 w/Factory 7-Way		10
		06-10	Jeep Commander w/Factory 7-Way		10
		00-10	Jeep Grand Cherokee w/Factory 7-Way		10
		05-08	Jeep Liberty w/Factory 7-Way		10
		06-09	Mitsubishi Raider w/Factory 7-Way		10
	20137	03-06	Lexus GX470 w/Factory 7-Way	1	10
		03-06	Toyota 4Runner w/Factory 7-Way		10
		03-04	Toyota Sequoia w/Factory 7-Way		10
		03-06	Toyota Tundra w/Factory 7-Way		10
E12	22111	08-12	Buick Enclave	2	25
		09-12	Chevrolet Traverse		25
	22112	14-16	RAM ProMaster 1500 All Models	4	60
		14-16	RAM ProMaster 2500 All Models	16	60
		14-16	RAM ProMaster 3500 All Models	60	60
	22113	14-17	Dodge Durango	4	60
	22114	15-17	Ford Transit-150	5	90
		15-17	Ford Transit-250		90
	22116	15-17	Ford Transit-350	5	90
FIFTH WHEEL HARNESS					
	20110	07	Chevrolet Silverado 1500 (Classic), w/Factory 7-Way	2	45
		07	Chevrolet Silverado 1500 HD (Classic), w/Factory 7-Way		45
		01-06	Chevrolet Silverado 1500 HD w/Factory 7-Way		45
		99-17	Chevrolet Silverado 1500 w/Factory 7-Way		45

6 / 7-WAY CONNECTOR APPLICATION NUMERICAL

PC	PART NO.	YEARS	MAKE/MODEL	WGT LBS	IN
	54701-003	11-17	RAM 2500 w/Factory 7-Way	4	45
		11-17	RAM 3500 w/Factory 7-Way		45
		10-14	Toyota Tundra w/Factory 7-Way		45
	54701-004	07-09	Toyota Tundra w/Factory 7-Way	4	45
	54701-007	11-16	Ford F-250 Super Duty w/Factory 7-Way	12	45
		11-16	Ford F-350 Super Duty w/Factory 7-Way		45
		11-16	Ford F-450 Super Duty w/Factory 7-Way		45
	54701-009	11-16	Ford F-250 Super Duty w/Factory 7-Way	4	45
		11-16	Ford F-350 Super Duty w/Factory 7-Way		45
		11-16	Ford F-450 Super Duty w/Factory 7-Way		45
6 / 7-WAY CONNECTORS					
	118015	08-12	Buick Enclave w/Factory 7-Way		10
		04-07	Buick Rainier w/Factory 7-Way		10
		03-15	Cadillac Escalade ESV w/Factory 7-Way		10
		02-11	Cadillac Escalade EXT w/Factory 7-Way		10
		02-16	Cadillac Escalade w/Factory 7-Way		10
		02-06	Chevrolet Avalanche 1500 w/Factory 7-Way		10
		02-06	Chevrolet Avalanche 2500 w/Factory 7-Way		10
		07-11	Chevrolet Avalanche w/Factory 7-Way		10
		99-01	Chevrolet Blazer Downsize, w/Factory 7-Way		10
		99-01	Chevrolet Blazer Trailblazer w/Factory 7-Way		10
		04-12	Chevrolet Colorado w/Factory 7-Way		10
		07	Chevrolet Silverado 1500 (Classic), w/Factory 7-Way		10
		07	Chevrolet Silverado 1500 HD (Classic), w/Factory 7-Way		10
		01-06	Chevrolet Silverado 1500 HD w/Factory 7-Way		10
		99-17	Chevrolet Silverado 1500 w/Factory 7-Way		10
		07	Chevrolet Silverado 2500 HD (Classic), w/Factory 7-Way		10
		01-16	Chevrolet Silverado 2500 HD w/Factory 7-Way		10
		99-04	Chevrolet Silverado 2500 w/Factory 7-Way		10
		07	Chevrolet Silverado 3500 (Classic), w/Factory 7-Way		10
		07-16	Chevrolet Silverado 3500 HD w/Factory 7-Way		10
		01-06	Chevrolet Silverado 3500 w/Factory 7-Way		10
		00-14	Chevrolet Suburban 1500 w/Amber Turn Signals, w/Factory 7-Way		10
		00-13	Chevrolet Suburban 2500 w/Amber Turn Signals, w/Factory 7-Way		10
		00-11	Chevrolet Tahoe w/Amber Turn Signals, w/Factory 7-Way		10
		02-09	Chevrolet TrailBlazer w/Factory 7-Way		10
		09-12	Chevrolet Traverse w/Factory 7-Way		10
		09	Chrysler Aspen w/Factory 7-Way		10
		09	Dodge Durango w/Factory 7-Way		10
		09-10	Dodge Ram 1500 w/Factory 7-Way		10
		10	Dodge Ram 2500 w/Factory 7-Way		10
		10	Dodge Ram 3500 w/Factory 7-Way		10
		97-09	Ford E-150 Econoline w/Factory 7-Way		10
		97-09	Ford E-250 Econoline w/Factory 7-Way		10
		97-09	Ford E-350 Econoline w/Factory 7-Way		10
		00-05	Ford Excursion w/Factory 7-Way		10
		97-15	Ford Expedition w/Factory 7-Way		10
		00-03	Ford Explorer 2 Dr. Sport, w/Factory 7-Way		10
		00-10	Ford Explorer 4 Dr., w/Factory 7-Way		10
		07-10	Ford Explorer Sport Trac w/Factory 7-Way		10
		11-17	Ford Explorer w/Factory 7-Way		10
		04	Ford F-150 Heritage w/Factory 7-Way		10
		97-17	Ford F-150 w/Factory 7-Way		10
		97-99	Ford F-250 Styleside, w/Factory 7-Way		10
		99-16	Ford F-250 Super Duty w/Factory 7-Way		10
		99-16	Ford F-350 Super Duty w/Factory 7-Way		10
		99-15	Ford F-450 Super Duty w/Factory 7-Way		10
		99-11	Ford F-550 Super Duty w/Factory 7-Way		10
		09-16	Ford Flex w/Factory 7-Way		10
		00-11	Ford Ranger w/Factory 7-Way		10
		07-12	GMC Acadia w/Factory 7-Way		10
		04-12	GMC Canyon w/Factory 7-Way		10
		02-09	GMC Envoy w/Factory 7-Way		10
		99-01	GMC Jimmy Downsize, w/Factory 7-Way		10
		07	GMC Sierra 1500 (Classic), w/Factory 7-Way		10
		07	GMC Sierra 1500 HD (Classic), w/Factory 7-Way		10
		01-06	GMC Sierra 1500 HD w/Factory 7-Way		10
		99-17	GMC Sierra 1500 w/Factory 7-Way		10
		07	GMC Sierra 2500 HD (Classic), w/Factory 7-Way		10
		01-16	GMC Sierra 2500 HD w/Factory 7-Way		10
		99-04	GMC Sierra 2500 w/Factory 7-Way		10
		07	GMC Sierra 3500 (Classic), w/Factory 7-Way		10
		07-16	GMC Sierra 3500 HD w/Factory 7-Way		10
		01-06	GMC Sierra 3500 w/Factory 7-Way		10
		01-16	GMC Yukon Denali w/Amber Turn Signals, w/Factory 7-Way		10
		00-16	GMC Yukon w/Amber Turn Signals, w/Factory 7-Way		10
		01-16	GMC Yukon XL 1500 Denali w/Factory 7-Way		10
		00-11	GMC Yukon XL 1500 w/Factory 7-Way		10
		11-12	GMC Sierra Denali HD, w/Factory 7-Way		10

PC	PART NO.	YEARS	MAKE/MODEL	WGT LBS	IN
	118015	00-16	GMC Yukon w/Amber Turn Signals, w/Factory 7-Way		10
		00-11	GMC Yukon XL 1500 w/Factory 7-Way		10
		00-13	GMC Yukon XL 2500 w/Factory 7-Way		10
		03-09	Hummer H2 w/Factory 7-Way		10
		06-10	Hummer H3 w/Factory 7-Way		10
		09-10	Hummer H3T w/Factory 7-Way		10
		04-12	Infiniti QX56 w/Factory 7-Way		10
		03-08	Isuzu Ascender w/Factory 7-Way		10
		11-15	Jeep Grand Cherokee w/Factory 7-Way		10
		09-12	Jeep Liberty w/Factory 7-Way		10
		09-11	KIA Borrego w/Factory 7-Way		10
		10-11	Lexus GX460 w/Factory 7-Way		10
		03-05	Lincoln Aviator w/Factory 7-Way		10
		06-08	Lincoln Mark LT w/Factory 7-Way		10
		10-12	Lincoln MKT w/Factory 7-Way		10
		98-11	Lincoln Navigator w/Factory 7-Way		10
		00-10	Mercury Mountaineer w/Factory 7-Way		10
		05-14	Nissan Armada w/Factory 7-Way		10
		04	Nissan Pathfinder Armada w/Factory 7-Way		10
		04-14	Nissan Titan w/Factory 7-Way		10
		99-04	Oldsmobile Bravada w/Factory 7-Way		10
		11-17	RAM 1500 w/Factory 7-Way		10
		11-17	RAM 2500 w/Factory 7-Way		10
		11-17	RAM 3500 w/Factory 7-Way		10
		05-09	Saab 9-7X w/Factory 7-Way		10
		07-09	Saturn Outlook w/Factory 7-Way		10
		10-11	Toyota 4Runner w/Factory 7-Way		10
		09-12	Toyota Tacoma w/Factory 7-Way		10
		10-13	Toyota Tundra w/Factory 7-Way		10
	20047	08-12	Buick Enclave w/Factory 7-Way		10
		04-07	Buick Rainier w/Factory 7-Way		10
		03-11	Cadillac Escalade ESV w/Factory 7-Way		10
		02-11	Cadillac Escalade EXT w/Factory 7-Way		10
		02-16	Cadillac Escalade w/Factory 7-Way		10
		02-06	Chevrolet Avalanche 1500 w/Factory 7-Way		10
		02-06	Chevrolet Avalanche 2500 w/Factory 7-Way		10
		07-11	Chevrolet Avalanche w/Factory 7-Way		10
		99-01	Chevrolet Blazer Downsize, w/Factory 7-Way		10
		99-01	Chevrolet Blazer Trailblazer w/Factory 7-Way		10
		04-12	Chevrolet Colorado w/Factory 7-Way		10
		07	Chevrolet Silverado 1500 (Classic), w/Factory 7-Way		10
		07	Chevrolet Silverado 1500 HD (Classic), w/Factory 7-Way		10
		01-06	Chevrolet Silverado 1500 HD w/Factory 7-Way		10
		99-17	Chevrolet Silverado 1500 w/Factory 7-Way		10
		07	Chevrolet Silverado 2500 HD (Classic), w/Factory 7-Way		10
		01-16	Chevrolet Silverado 2500 HD w/Factory 7-Way		10
		99-04	Chevrolet Silverado 2500 w/Factory 7-Way		10
		07	Chevrolet Silverado 3500 (Classic), w/Factory 7-Way		10
		07-16	Chevrolet Silverado 3500 HD w/Factory 7-Way		10
		01-06	Chevrolet Silverado 3500 w/Factory 7-Way		10
		00-14	Chevrolet Suburban 1500 w/Amber Turn Signals, w/Factory 7-Way		10
		00-13	Chevrolet Suburban 2500 w/Amber Turn Signals, w/Factory 7-Way		10
		00-11	Chevrolet Tahoe w/Amber Turn Signals, w/Factory 7-Way		10
		02-09	Chevrolet TrailBlazer w/Factory 7-Way		10
		09-12	Chevrolet Traverse w/Factory 7-Way		10
		07-12	GMC Acadia w/Factory 7-Way		10
		04-12	GMC Canyon w/Factory 7-Way		10
		02-09	GMC Envoy w/Factory 7-Way		10
		99-01	GMC Jimmy Downsize, w/Factory 7-Way		10
		07	GMC Sierra 1500 (Classic), w/Factory 7-Way		10
		07	GMC Sierra 1500 HD (Classic), w/Factory 7-Way		10
		01-06	GMC Sierra 1500 HD w/Factory 7-Way		10
		99-17	GMC Sierra 1500 w/Factory 7-Way		10
		07	GMC Sierra 2500 HD (Classic), w/Factory 7-Way		10
		11-12	GMC Sierra 2500 HD Denali HD, w/Factory 7-Way		10
		01-16	GMC Sierra 2500 HD w/Factory 7-Way		10
		99-04	GMC Sierra 2500 w/Factory 7-Way		10
		07	GMC Sierra 3500 (Classic), w/Factory 7-Way		10
		07-16	GMC Sierra 3500 HD w/Factory 7-Way		10
		01-06	GMC Sierra 3500 w/Factory 7-Way		10
		01-16	GMC Yukon Denali w/Amber Turn Signals, w/Factory 7-Way		10
		00-16	GMC Yukon w/Amber Turn Signals, w/Factory 7-Way		10
		01-16	GMC Yukon XL 1500 Denali w/Factory 7-Way		10
		00-11	GMC Yukon XL 1500 w/Factory 7-Way		10
		00-13	GMC Yukon XL 2500 w/Factory 7-Way		10

FIFTH WHEEL RAIL KIT APPLICATION NUMERICAL

PC	PART NO.	YEARS	MAKE/MODEL	WGT LBS	IN
	20047	00-13	GMC Yukon XL 2500 w/Factory 7-Way		10
		03-09	Hummer H2 w/Factory 7-Way		10
		06-10	Hummer H3 w/Factory 7-Way		10
		09-10	Hummer H3T w/Factory 7-Way		10
		03-08	Isuzu Ascender w/Factory 7-Way		10
		99-04	Oldsmobile Bravada w/Factory 7-Way		10
		05-09	Saab 9-7X w/Factory 7-Way		10
		07-09	Saturn Outlook w/Factory 7-Way		10
20K / 22K / 25K FIFTH WHEEL					
	30160	13-15	RAM 2500 w/Factory HD Towing Option	220	
		14-16	RAM 3500 w/Factory HD Towing Option		
RAILS & BRACKET KITS					
	30035	73-86	Chevrolet C10	54	
		88-99	Chevrolet C1500		
		73-86	Chevrolet C20		
		88-99	Chevrolet C2500		
		73-86	Chevrolet C30		
		88-00	Chevrolet C3500		
		73-86	Chevrolet K10		
		88-99	Chevrolet K1500		
		73-86	Chevrolet K20		
		88-99	Chevrolet K2500		
		73-86	Chevrolet K30		
		88-00	Chevrolet K3500		
		99-17	Chevrolet Silverado 1500		
		07	Chevrolet Silverado 1500 (Classic)		
		01-06	Chevrolet Silverado 1500 HD		
		07	Chevrolet Silverado 1500 HD (Classic)		
		99-04	Chevrolet Silverado 2500		
		01-16	Chevrolet Silverado 2500 HD		
		07	Chevrolet Silverado 2500 HD (Classic)		
		01-06	Chevrolet Silverado 3500		
		07	Chevrolet Silverado 3500 (Classic)		
		07-16	Chevrolet Silverado 3500 HD		
		73-89	Dodge D100		
		77-93	Dodge D150		
		73-80	Dodge D200		
		81-93	Dodge D250		
		73-80	Dodge D300		
		81-93	Dodge D350		
		94-04	Dodge Dakota		
		94-10	Dodge Ram 1500		
		94-02	Dodge Ram 2500		
		03-10	Dodge Ram 2500 Except w/Overload Springs		
		03-10	Dodge Ram 2500 w/Overload Springs		
		94-02	Dodge Ram 3500		
		03-10	Dodge Ram 3500 Except w/Overload Springs		
		03-10	Dodge Ram 3500 w/Overload Springs		
		75-83	Ford F-100		
		75-16	Ford F-150		
		04	Ford F-150 Heritage Styleside		
		97-03	Ford F-150 Styleside, Except SuperCrew		
		75-96	Ford F-250		
		97	Ford F-250 Heavy Duty		
		97-99	Ford F-250 Styleside		
		99-16	Ford F-250 Super Duty Except Cab & Chassis		
		75-96	Ford F-350		
		97	Ford F-350 Heavy Duty		
		99-16	Ford F-350 Super Duty Except Cab & Chassis		
		08-16	Ford F-450 Super Duty Except Cab & Chassis		
		75-78	GMC C15		
		73-74	GMC C15/C1500		
		79-99	GMC C1500		
		75-78	GMC C25		
		67-74	GMC C25/C2500		
		79-00	GMC C2500		
		75-78	GMC C35		
		73-74	GMC C35/C3500		
		79-00	GMC C3500		
		92-00	GMC C3500 Crew Cab		
		73-78	GMC K15		
		79-99	GMC K1500		
		73-78	GMC K25		
		79-00	GMC K2500		
		73-78	GMC K35		
		79-00	GMC K3500		
		92-00	GMC K3500 Crew Cab		

PC	PART NO.	YEARS	MAKE/MODEL	WGT LBS	IN
	30035	07	GMC Sierra 1500 (Classic)	54	
		01-06	GMC Sierra 1500 HD		
		07	GMC Sierra 1500 HD (Classic)		
		99-04	GMC Sierra 2500		
		01-16	GMC Sierra 2500 HD		
		07	GMC Sierra 2500 HD (Classic)		
		01-06	GMC Sierra 3500		
		07	GMC Sierra 3500 (Classic)		
		07-16	GMC Sierra 3500 HD		
		04-15	Nissan Titan		
		11-12	RAM 1500		
		14-17	RAM 1500 Except w/Air Suspension		
		13-17	RAM 1500 Except w/Air Suspension or w/ECODiesel Engine		
		14-17	RAM 2500		
		11-13	RAM 2500 Except w/Overload Springs		
		11-12	RAM 2500 w/Overload Springs		
		13-14	RAM 3500		
		11-12	RAM 3500 Except w/Overload Springs		
		11-12	RAM 3500 w/Overload Springs		
		07-17	Toyota Tundra		
		00-06	Toyota Tundra Regular Cab 8 ft. Bed		
	50026	11-16	Ford F-250 Super Duty Except Cab & Chassis	27	
		11-16	Ford F-350 Super Duty Except Cab & Chassis		
		11-16	Ford F-450 Super Duty Except Cab & Chassis		
	50026-58	11-16	Ford F-250 Super Duty Except Cab & Chassis	66	
		11-16	Ford F-350 Super Duty Except Cab & Chassis		
		11-16	Ford F-450 Super Duty Except Cab & Chassis		
	50040	02-08	Dodge Ram 1500 Except Mega Cab	60	
		03-10	Dodge Ram 2500 Except Mega Cab & w/Overload Springs		
		03-10	Dodge Ram 3500 Except Mega Cab & w/Overload Springs		
		11-12	RAM 2500 Except Mega Cab & w/Overload Springs		
		11-12	RAM 3500 Except Mega Cab & w/Overload Springs		
	50040-58	02-08	Dodge Ram 1500 Except Mega Cab	98	
		03-10	Dodge Ram 2500 Except Mega Cab & w/Overload Springs		
		03-10	Dodge Ram 3500 Except Mega Cab & w/Overload Springs		
		11-12	RAM 2500 Except Mega Cab & w/Overload Springs		
		11-12	RAM 3500 Except Mega Cab & w/Overload Springs		
	50042	04	Ford F-150 Heritage Styleside	28	
		97-03	Ford F-150 Styleside		
		97-99	Ford F-250 Styleside		
	50042-58	04	Ford F-150 Heritage Styleside	66	
		97-03	Ford F-150 Styleside		
		97-99	Ford F-250 Styleside		
	50043	99-04	Ford F-250 Super Duty Except Cab & Chassis	24	
		99-04	Ford F-350 Super Duty Except Cab & Chassis		
	50043-58	99-04	Ford F-250 Super Duty Except Cab & Chassis	64	
		99-04	Ford F-350 Super Duty Except Cab & Chassis		
	50054	14-17	RAM 2500	18	
	50054-58	14-17	RAM 2500	58	
	50064	99-06	Chevrolet Silverado 1500	42	
		07	Chevrolet Silverado 1500 (Classic)		
		07-17	Chevrolet Silverado 1500 Does Not Fit MagneRide Magnetic Ride Suspension		
		01-06	Chevrolet Silverado 1500 HD		
		07	Chevrolet Silverado 1500 HD (Classic)		
		99-04	Chevrolet Silverado 2500		
		01-10	Chevrolet Silverado 2500 HD		
		07	Chevrolet Silverado 2500 HD (Classic)		
		01-06	Chevrolet Silverado 3500		
		07	Chevrolet Silverado 3500 (Classic)		
		07-10	Chevrolet Silverado 3500 HD		
		99-06	GMC Sierra 1500		
		07	GMC Sierra 1500 (Classic)		
		07-17	GMC Sierra 1500 Does Not Fit MagneRide Magnetic Ride Suspension		
		01-06	GMC Sierra 1500 HD		
		07	GMC Sierra 1500 HD (Classic)		
		99-04	GMC Sierra 2500		
		01-10	GMC Sierra 2500 HD		
		07	GMC Sierra 2500 HD (Classic)		
		01-06	GMC Sierra 3500		
		07	GMC Sierra 3500 (Classic)		
		07-10	GMC Sierra 3500 HD		
	50064-24†	99-17	Chevrolet Silverado 1500	47	
		07	Chevrolet Silverado 1500 (Classic)		
		01-06	Chevrolet Silverado 1500 HD		
		07	Chevrolet Silverado 1500 HD (Classic)		

† = Available while supplies last.

FIFTH WHEEL RAIL KIT APPLICATION NUMERICAL

PC	PART NO.	YEARS	MAKE/MODEL	WGT LBS	IN				
50064-24†		99-04	Chevrolet Silverado 2500	47					
		01-10	Chevrolet Silverado 2500 HD						
		07	Chevrolet Silverado 2500 HD (Classic)						
		01-06	Chevrolet Silverado 3500						
		07	Chevrolet Silverado 3500 (Classic)						
		07-10	Chevrolet Silverado 3500 HD						
		99-17	GMC Sierra 1500						
		07	GMC Sierra 1500 (Classic)						
		01-06	GMC Sierra 1500 HD						
		07	GMC Sierra 1500 HD (Classic)						
		99-04	GMC Sierra 2500						
		01-10	GMC Sierra 2500 HD						
		07	GMC Sierra 2500 HD (Classic)						
		01-06	GMC Sierra 3500						
		07	GMC Sierra 3500 (Classic)						
		07-10	GMC Sierra 3500 HD						
		50064-58				99-17	Chevrolet Silverado 1500	47	
07	Chevrolet Silverado 1500 (Classic)								
01-06	Chevrolet Silverado 1500 HD								
07	Chevrolet Silverado 1500 HD (Classic)								
99-04	Chevrolet Silverado 2500								
01-10	Chevrolet Silverado 2500 HD								
07	Chevrolet Silverado 2500 HD (Classic)								
01-06	Chevrolet Silverado 3500								
07	Chevrolet Silverado 3500 (Classic)								
07-10	Chevrolet Silverado 3500 HD								
99-17	GMC Sierra 1500								
07	GMC Sierra 1500 (Classic)								
01-06	GMC Sierra 1500 HD								
07	GMC Sierra 1500 HD (Classic)								
07-10	GMC Sierra 3500 HD								
50066				11-16	Chevrolet Silverado 2500 HD	31			
				11-16	Chevrolet Silverado 3500 HD				
		11-16	GMC Sierra 2500 HD						
		11-16	GMC Sierra 3500 HD						
50066-24†		11-16	Chevrolet Silverado 2500 HD	72					
		11-16	Chevrolet Silverado 3500 HD						
		11-16	GMC Sierra 2500 HD						
		11-16	GMC Sierra 3500 HD						
50066-58		11-16	Chevrolet Silverado 2500 HD	76					
		11-16	Chevrolet Silverado 3500 HD						
		11-16	GMC Sierra 2500 HD						
		11-16	GMC Sierra 3500 HD						
50074		17	Ford F-250 Super Duty Single Rear Wheel, Except Cab & Chassis	28					
		17	Ford F-350 Super Duty Single Rear Wheel, Except Cab & Chassis						
50074-58		17	Ford F-250 Super Duty Single Rear Wheel, Except Cab & Chassis	1					
		17	Ford F-350 Super Duty Single Rear Wheel, Except Cab & Chassis						
50081		04-14	Ford F-150	24					
50081-58		04-14	Ford F-150	63					
50082		99-10	Ford F-250 Super Duty Except Cab & Chassis	31					
		99-10	Ford F-350 Super Duty Except Cab & Chassis						
		08-10	Ford F-450 Super Duty Except Cab & Chassis						
50082-24†		99-10	Ford F-250 Super Duty Except Cab & Chassis	67					
		99-10	Ford F-350 Super Duty Except Cab & Chassis						
		08-10	Ford F-450 Super Duty Except Cab & Chassis						
50082-58		99-10	Ford F-250 Super Duty Except Cab & Chassis	73					
		99-10	Ford F-350 Super Duty Except Cab & Chassis						
		08-10	Ford F-450 Super Duty Except Cab & Chassis						
50084		07-17	Toyota Tundra	32					
50084-58		07-17	Toyota Tundra	86					
50085		13-16	RAM 3500	30					
50085-58		13-16	RAM 3500	70					
50087		15-16	Ford F-150	27					
50087-58		15-16	Ford F-150	46					
50140		06-08	Dodge Ram 1500 Mega Cab	24					
		03-09	Dodge Ram 2500						
		10	Dodge Ram 2500 Except w/Gas Engines w/Overload Springs						
		03-09	Dodge Ram 3500						

PC	PART NO.	YEARS	MAKE/MODEL	WGT LBS	IN
50140		10	Dodge Ram 3500 Except w/Gas Engines w/Overload Springs	24	
		11-12	RAM 2500 Except w/Gas Engines w/Overload Springs		
		11-12	RAM 3500 Except w/Gas Engines w/Overload Springs		
50140-58		06-08	Dodge Ram 1500 Mega Cab	65	
		03-09	Dodge Ram 2500		
		10	Dodge Ram 2500 Except w/Gas Engines w/Overload Springs		
		03-09	Dodge Ram 3500		
		10	Dodge Ram 3500 Except w/Gas Engines w/Overload Springs		
		11-12	RAM 2500 Except w/Gas Engines w/Overload Springs		
		11-12	RAM 3500 Except w/Gas Engines w/Overload Springs		
50141		14-17	RAM 1500 Except w/Air Suspension or 5.7 ft. Bed	31	
50142		09-10	Dodge Ram 1500	38	
		11-17	RAM 1500		
50142-58		09-10	Dodge Ram 1500	78	
		11-17	RAM 1500		
56001		11-16	Chevrolet Silverado 2500 HD	22	
		11-16	Chevrolet Silverado 3500 HD		
		11-16	GMC Sierra 2500 HD		
		11-16	GMC Sierra 3500 HD		
56001-53		11-16	Chevrolet Silverado 2500 HD	84	
		11-16	Chevrolet Silverado 3500 HD		
		11-16	GMC Sierra 3500 HD		
56004†		08-10	Chevrolet Silverado 2500 HD	27	
		08-10	Chevrolet Silverado 3500 HD		
		08-10	GMC Sierra 3500 HD		
56005		99-10	Ford F-250 Super Duty Except Cab & Chassis	28	
		99-10	Ford F-350 Super Duty Except Cab & Chassis		
		08-10	Ford F-450 Super Duty Except Cab & Chassis		
56005-53		99-10	Ford F-250 Super Duty Except Cab & Chassis	89	
		99-10	Ford F-350 Super Duty Except Cab & Chassis		
		08-10	Ford F-450 Super Duty Except Cab & Chassis		
56006		04-14	Ford F-150	28	
56006-53		04-14	Ford F-150	89	
56007		99-06	Chevrolet Silverado 1500	36	
		07	Chevrolet Silverado 1500 (Classic)		
		07-17	Chevrolet Silverado 1500 Does Not Fit MagneRide Magnetic Ride Suspension		
		01-06	Chevrolet Silverado 1500 HD		
		07	Chevrolet Silverado 1500 HD (Classic)		
		99-04	Chevrolet Silverado 2500		
		01-10	Chevrolet Silverado 2500 HD		
		07	Chevrolet Silverado 2500 HD (Classic)		
		01-06	Chevrolet Silverado 3500		
		07	Chevrolet Silverado 3500 (Classic)		
		07-10	Chevrolet Silverado 3500 HD		
		99-06	GMC Sierra 1500		
		07	GMC Sierra 1500 (Classic)		
		07-17	GMC Sierra 1500 Does Not Fit MagneRide Magnetic Ride Suspension		
		01-06	GMC Sierra 1500 HD		
		07	GMC Sierra 1500 HD (Classic)		
		99-04	GMC Sierra 2500		
01-10	GMC Sierra 2500 HD				
07	GMC Sierra 2500 HD (Classic)				
01-06	GMC Sierra 3500				
07	GMC Sierra 3500 (Classic)				
07-10	GMC Sierra 3500 HD				
56007-53		99-17	Chevrolet Silverado 1500	97	
		07	Chevrolet Silverado 1500 (Classic)		
		01-06	Chevrolet Silverado 1500 HD		
		07	Chevrolet Silverado 1500 HD (Classic)		
		99-04	Chevrolet Silverado 2500		
		01-10	Chevrolet Silverado 2500 HD		
		07	Chevrolet Silverado 2500 HD (Classic)		
		01-06	Chevrolet Silverado 3500		
		07	Chevrolet Silverado 3500 (Classic)		
		07-10	Chevrolet Silverado 3500 HD		
		99-17	GMC Sierra 1500		
07	GMC Sierra 1500 (Classic)				
01-06	GMC Sierra 1500 HD				
07	GMC Sierra 1500 HD (Classic)				
99-04	GMC Sierra 2500				
01-10	GMC Sierra 2500 HD				
07	GMC Sierra 2500 HD (Classic)				
01-06	GMC Sierra 3500				

† = Available while supplies last.

FIFTH WHEEL RAIL KIT APPLICATION NUMERICAL

PC	PART NO.	YEARS	MAKE/MODEL	WGT LBS	IN
	56007-53	07-10	GMC Sierra 3500 (Classic) GMC Sierra 3500 HD	97	
	56009	14-17	RAM 2500	20	
	56009-53	14-17	RAM 2500	81	
	56010	13-14 15-16	RAM 3500 Except w/RamBox Cargo Management System RAM 3500 Except w/RamBox Cargo Management System or Models w/Air Suspension	40	
	56010-53	13-14 15-16	RAM 3500 Except w/RamBox Cargo Management System RAM 3500 Except w/RamBox Cargo Management System or Models w/Air Suspension	101	
	56011	03-10 03-10 11-13 11-12	Dodge Ram 2500 Dodge Ram 3500 RAM 2500 RAM 3500	48	
	56011-53	03-10 03-10 11-13 11-12	Dodge Ram 2500 Dodge Ram 3500 RAM 2500 RAM 3500	108	
	56014†	08-10 08-10 08-10 08-10	Chevrolet Silverado 2500 HD 6.6 ft. Bed Chevrolet Silverado 3500 HD 6.6 ft. Bed GMC Sierra 2500 HD 6.6 ft. Bed GMC Sierra 3500 HD 6.6 ft. Bed	35	
	56014-53†	08-10 08-10 08-10 08-10	Chevrolet Silverado 2500 HD Chevrolet Silverado 3500 HD GMC Sierra 2500 HD GMC Sierra 3500 HD	96	
	56016	11-16 11-16 11-16	Ford F-250 Super Duty Except Cab & Chassis Ford F-350 Super Duty Except Cab & Chassis Ford F-450 Super Duty Except Cab & Chassis	30	
	56016-53	11-16 11-16 11-16	Ford F-250 Super Duty Except Cab & Chassis Ford F-350 Super Duty Except Cab & Chassis Ford F-450 Super Duty Except Cab & Chassis	84	
	56017	17 17 17	Ford F-250 Super Duty Except Cab & Chassis Ford F-350 Super Duty Except Cab & Chassis Ford F-450 Super Duty Except Cab & Chassis	30	
	56017-53	17 17 17	Ford F-250 Super Duty Except Cab & Chassis Ford F-350 Super Duty Except Cab & Chassis Ford F-450 Super Duty Except Cab & Chassis	61	
	56034	15-16	Ford F-150	28	
	56034-53	15-16	Ford F-150	82	
	58023	02-08 03-10 03-10 11-12 11-12	Dodge Ram 1500 Dodge Ram 2500 Except w/Overload Springs Dodge Ram 3500 Except w/Overload Springs RAM 2500 Except w/Overload Springs RAM 3500 Except w/Overload Springs	3	
	58166	02-08 03-10 03-10 11-12 11-12	Dodge Ram 1500 Dodge Ram 2500 Except w/Overload Springs Dodge Ram 3500 Except w/Overload Springs RAM 2500 Except w/Overload Springs RAM 3500 Except w/Overload Springs	1	
	58186	03-10 03-10 11-12 11-12	Dodge Ram 2500 w/Overload Springs Dodge Ram 3500 w/Overload Springs RAM 2500 w/Overload Springs RAM 3500 w/Overload Springs	12	
	58197	00-06	Toyota Tundra Regular Cab 8 ft. Bed	1	
	58309	07-17	Toyota Tundra	3	
	58386	09-10 11-12 13-17	Dodge Ram 1500 RAM 1500 RAM 1500 Except w/Air Suspension or w/ECODiesel Engine	18	
	58405	04-15	Nissan Titan	26	
	58425	05-15 05-15 08-15	Ford F-250 Super Duty Except Cab & Chassis Ford F-350 Super Duty Except Cab & Chassis Ford F-450 Super Duty Except Cab & Chassis	4	
	58426	04-14	Ford F-150	16	
	58432	02-08	Dodge Ram 1500 Except Mega Cab	7	
	58433	09-10 11-12 13-14	Dodge Ram 1500 RAM 1500 Except 5.7 ft. Bed RAM 1500 Except 5.7 ft. Bed and Models w/Air Suspension	4	
	58520	13-16	RAM 3500	1	
	58522	14-17	RAM 2500	12	
	58523	09-10 11-12 14-17 13	Dodge Ram 1500 RAM 1500 RAM 1500 Except w/Air Suspension RAM 1500 Except w/Air Suspension or w/ECODiesel Engine	19	
	58531	15-16	Ford F-150	8	

PC	PART NO.	YEARS	MAKE/MODEL	WGT LBS	IN
ELITE SERIES RAIL KITS					
	30061	99-06 07 01-06 07 99-04 01-10 07-10 99-06 07 01-06 07 99-04 01-10 07-10	Chevrolet Silverado 1500 Except 8 ft. Bed Chevrolet Silverado 1500 Except 8 ft. Bed(Classic) Chevrolet Silverado 1500 HD Chevrolet Silverado 1500 HD (Classic) Chevrolet Silverado 2500 Except 8 ft. Bed Chevrolet Silverado 2500 HD Except 8 ft. Bed Chevrolet Silverado 3500 HD Except 8 ft. Bed GMC Sierra 1500 Except 8 ft. Bed GMC Sierra 1500 Except 8 ft. Bed (Classic) GMC Sierra 1500 HD GMC Sierra 1500 HD (Classic) GMC Sierra 2500 Except 8 ft. Bed GMC Sierra 2500 HD Except 8 ft. Bed GMC Sierra 3500 HD Except 8 ft. Bed	55	150 150 150 150 150 150 150 150 150 150 150 150 150 150
	30064	04-14	Ford F-150	62	120
	30067	02-08 03-10 03-10 11-12 11-12	Dodge Ram 1500 Except Mega Cab Dodge Ram 2500 Except Mega Cab Dodge Ram 3500 Except Mega Cab RAM 2500 Except Mega Cab RAM 3500 Except Mega Cab	55	120 120 120 120 120
	30073	99-10 99-10 08-10	Ford F-250 Super Duty Except Cab & Chassis Ford F-350 Super Duty Except Cab & Chassis Ford F-450 Super Duty Except Cab & Chassis	86	120 120 120
	30074	02-08 03-10 03-10 11-13 11-12	Dodge Ram 1500 Dodge Ram 2500 Dodge Ram 3500 RAM 2500 RAM 3500	85	120 120 120 120 120
	30126	11-16 11-16 11-16	Ford F-250 Super Duty Except Cab & Chassis Ford F-350 Super Duty Except Cab & Chassis Ford F-450 Super Duty Except Cab & Chassis	105	
	30852	10 10 11-12 11-12	Dodge Ram 2500 Dodge Ram 3500 RAM 2500 RAM 3500	113	
	30868	11-16 11-16 11-16 11-16	Chevrolet Silverado 2500 HD Chevrolet Silverado 3500 HD GMC Sierra 2500 HD GMC Sierra 3500 HD	120	
ELITE SERIES ACCESS.					
	30154	13-15 13-16	RAM 2500 w/Factory HD Towing Option RAM 3500 w/Factory HD Towing Option	90	
	30156	11-17 11-17	Ford F-250 Super Duty w/Hitch Prep Package Ford F-350 Super Duty w/Hitch Prep Package	54	
ELITE SERIES GOOSENECK					
	30138-26	11-15 11-15 11-15	Ford F-250 Super Duty Except Cab & Chassis Ford F-350 Super Duty Except Cab & Chassis Ford F-450 Super Duty Except Cab & Chassis	120	
	30158-52	10 10 11-12 11-12	Dodge Ram 2500 Dodge Ram 3500 RAM 2500 RAM 3500	163	
	30158-68	11-16 11-16 11-16 11-16	Chevrolet Silverado 2500 HD Chevrolet Silverado 3500 HD GMC Sierra 2500 HD GMC Sierra 3500 HD	170	
UNDER-BED GOOSENECK					
	9460-39	94-01 94-02 94-02	Dodge Ram 1500 Dodge Ram 2500 Dodge Ram 3500	91	90 90 90
	9460-48†	99-15 99-15	Ford F-250 Super Duty Except Cab & Chassis Ford F-350 Super Duty Except Cab & Chassis	111	90 90
	9460-49	08-15	Ford F-450 Super Duty Except Cab & Chassis	121	90
	9464-35	06-08 03-10 03-10 11-12 11-12	Dodge Ram 1500 Mega Cab Dodge Ram 2500 Dodge Ram 3500 RAM 2500 RAM 3500	114	90 90 90 90 90
	9464-38	02-08	Dodge Ram 1500 Except Mega Cab	110	90
	9464-46	09-10 11-17	Dodge Ram 1500 RAM 1500 Except w/Air Suspension	121	90 90
	9464-57	10 10 11-13 11-12	Dodge Ram 2500 Dodge Ram 3500 RAM 2500 RAM 3500	128	110 110 125 110
	9465-34	99-04	Chevrolet Silverado 2500	106	105

† = Available while supplies last.

GOOSENECK APPLICATION NUMERICAL

PC	PART NO.	YEARS	MAKE/MODEL	WGT LBS	IN
	9465-34	01-10	Chevrolet Silverado 2500 HD	106	105
		07-10	Chevrolet Silverado 3500 HD		105
		99-04	GMC Sierra 2500		105
		01-10	GMC Sierra 2500 HD		105
		07-10	GMC Sierra 3500 HD		105
	9465-36	07-17	Toyota Tundra	93	90
	9465-37	04-14	Ford F-150	91	90
	9465-40	88-99	Chevrolet C1500	101	105
		88-99	Chevrolet C2500		105
		88-00	Chevrolet C3500 Except Crew Cab		105
		88-99	Chevrolet K1500		105
		88-99	Chevrolet K2500		105
		88-00	Chevrolet K3500 Except Crew Cab		105
		88-99	GMC C1500		105
		88-99	GMC C2500		105
		88-00	GMC C3500 Except Crew Cab		105
		88-99	GMC K1500		105
		88-99	GMC K2500		105
		88-00	GMC K3500 Except Crew Cab		105
	9465-45	01-07	Chevrolet Silverado 2500	106	90
		01-07	GMC Sierra 3500		90
	9465-54	99-17	Chevrolet Silverado 1500	96	105
		07	Chevrolet Silverado 1500 (Classic)		105
		01-06	Chevrolet Silverado 1500 HD		105
		07	Chevrolet Silverado 1500 HD (Classic)		105
		99-04	Chevrolet Silverado 2500 6.6 ft. Bed		105
		99-17	GMC Sierra 1500		105
		07	GMC Sierra 1500 (Classic)		105
		01-07	GMC Sierra 1500 HD		105
		99-04	GMC Sierra 2500 6.6 ft. Bed		105
	9465-56	11-16	Chevrolet Silverado 2500 HD	94	45
		11-16	Chevrolet Silverado 3500 HD		45
		11-16	GMC Sierra 2500 HD		45
		11-16	GMC Sierra 3500 HD		45
	9465-84	15	Ford F-150	91	90
	9465-91	15-16	Ford F-150	91	90
	9466	13-16	RAM 3500 (Gooseneck Head Does Not Require Rail Kit)	52	60
	9467	14-17	RAM 2500 (Gooseneck Head Does Not Require Rail Kit)	49	30
ABOVE-BED GOOSENECK					
	4434	99-02	Chevrolet Silverado 2500	70	105
		01-10	Chevrolet Silverado 2500 HD		105
		07-10	Chevrolet Silverado 3500 HD		105
		99-04	GMC Sierra 2500		105
		01-10	GMC Sierra 2500 HD		105
		07-10	GMC Sierra 3500 HD		105
	4435	06-08	Dodge Ram 1500 Mega Cab	70	90
		03-10	Dodge Ram 2500		90
		03-10	Dodge Ram 3500		90
		11-12	RAM 2500		90
		11-12	RAM 3500		90
	4436	07-17	Toyota Tundra	57	90
	4437	04-14	Ford F-150	55	90
	4438	02-08	Dodge Ram 1500 Except Mega Cab	66	90
	4439	94-01	Dodge Ram 1500	48	90
		94-02	Dodge Ram 2500		90
		94-02	Dodge Ram 3500		90
	4440	88-99	Chevrolet C1500	65	105
		88-99	Chevrolet C2500		105
		88-00	Chevrolet C3500 Except Crew Cab		105
		88-99	Chevrolet K1500		105
		88-99	Chevrolet K2500		105
		88-00	Chevrolet K3500 Except Crew Cab		105
		88-99	GMC C1500		105
		88-99	GMC C2500		105
		88-00	GMC C3500 Except Crew Cab		105
		88-99	GMC K1500		105
		88-99	GMC K2500		105
		88-00	GMC K3500 Except Crew Cab		105
	4445	01-06	Chevrolet Silverado 3500	61	90
		07	Chevrolet Silverado 3500 (Classic)		90
		01-06	GMC Sierra 3500		90
		07	GMC Sierra 3500 (Classic)		90
	4446	09-10	Dodge Ram 1500	82	90
		11-17	RAM 1500 Except w/Air Suspension		90
	4448†	99-15	Ford F-250 Super Duty Except Cab & Chassis	51	90
		99-15	Ford F-350 Super Duty Except Cab & Chassis		90
	4449	08-15	Ford F-450 Super Duty Except Cab & Chassis	78	90

PC	PART NO.	YEARS	MAKE/MODEL	WGT LBS	IN
	4454	99-17	Chevrolet Silverado 1500	57	105
		07	Chevrolet Silverado 1500 (Classic)		105
		01-06	Chevrolet Silverado 1500 HD		105
		07	Chevrolet Silverado 1500 HD (Classic)		105
		99-04	Chevrolet Silverado 2500 6.6 ft. Bed		105
		99-17	GMC Sierra 1500		105
		07	GMC Sierra 1500 (Classic)		105
		01-06	GMC Sierra 1500 HD		105
		07	GMC Sierra 1500 HD (Classic)		105
		99-04	GMC Sierra 2500 6.6 ft. Bed		105
	4456	11-16	Chevrolet Silverado 2500 HD	58	45
		11-16	Chevrolet Silverado 3500 HD		45
		11-16	GMC Sierra 2500 HD		45
		11-16	GMC Sierra 3500 HD		45
	4457	10	Dodge Ram 2500	84	110
		10	Dodge Ram 3500		110
		11-13	RAM 2500		125
		11-12	RAM 3500		110
	4484	15	Ford F-150	51	90
	4491	15-16	Ford F-150	51	90
ROOF RACKS					
	59631	15-17	RAM ProMaster City	7	15
	59632	15-17	RAM ProMaster City	11	15
	59633	15-17	RAM ProMaster City	18	15
	59636	16	Subaru Crosstrek Except w/Factory Roof Rails	9	10
		09-16	Subaru Forester Except w/Factory Roof Rails		10
		08-11	Subaru Impreza 4 Dr. Sedan, Except w/Factory Roof Rails		10
		08-16	Subaru Impreza 5 Dr. Wagon, Except w/Factory Roof Rails		10
		12-14	Subaru WRX 4 Dr. Sedan, Except w/Factory Roof Rails		10
		12-15	Subaru WRX 5 Dr. Wagon, Except w/Factory Roof Rails		10
		13-15	Subaru XV Crosstrek Except w/Factory Roof Rails		10
	59680	10-16	GMC Acadia w/Factory Roof Rails	10	15
	59681	12-16	Honda CR-V w/Factory Roof Rails	10	20
	59682	14-17	Jeep Cherokee w/Factory Roof Rails	10	10
	59684	15-16	KIA Sedona Except Panoramic Sunroof	12	10
	59685	15-16	Cadillac Escalade ESV w/Factory Roof Rails	10	15
		15-16	Cadillac Escalade w/Factory Roof Rails		15
		15-16	Chevrolet Suburban w/Factory Roof Rails		15
		15-16	Chevrolet Tahoe w/Factory Roof Rails		15
		15-16	GMC Yukon w/Factory Roof Rails		15
		15-16	GMC Yukon XL w/Factory Roof Rails		15
	59686	15-16	Jeep Renegade w/Factory Roof Rails	12	
	59707	12-14	Hyundai Accent 5 Dr. Hatchback, Except w/Factory Roof Rails	9	5
	59708	11-13	KIA Forte 5 Dr. Hatchback, Except w/Factory Roof Rails	10	15
	59709	09-13	Mazda 6 4 Dr. Sedan, Except w/Factory Roof Rails	10	10
	59711	07-13	Acura MDX w/Factory Roof Rails	14	15
		07-13	Chevrolet Avalanche w/Factory Roof Rails		15
		00-14	Chevrolet Suburban 1500 w/Factory Roof Rails		15
		92-99	Chevrolet Suburban C1500 w/Factory Roof Rails		15
		92-99	Chevrolet Suburban C2500 w/Factory Roof Rails		15
		92-99	Chevrolet Suburban K1500 w/Factory Roof Rails		15
		92-99	Chevrolet Suburban K2500 w/Factory Roof Rails		15
		95-14	Chevrolet Tahoe w/Factory Roof Rails		15
		11-15	Ford Explorer w/Factory Roof Rails		15
		00-14	GMC Yukon w/Amber Turn Signals		15
		92-00	GMC Yukon w/Factory Roof Rails		15
		00-14	GMC Yukon XL 1500 w/Factory Roof Rails		15
		00-13	GMC Yukon XL 2500 w/Factory Roof Rails		15
		98-02	Honda Passport w/Factory Roof Rails		15
		09-15	Honda Pilot w/Factory Roof Rails		15
		11-13	Infiniti QX56 w/Factory Roof Rails		15
		14-16	Infiniti QX80 w/Factory Roof Rails		15
		98-04	Isuzu Rodeo w/Factory Roof Rails		15
		08-12	Jeep Liberty w/Factory Roof Rails		15
		08-17	Jeep Patriot w/Factory Roof Rails		15
		04-07	Mazda 6 Sport Wagon w/Factory Roof Rails		15
		10-13	Mazda CX-9 w/Factory Roof Rails		15
		08-11	Mazda Tribute w/Factory Roof Rails		15
		04-16	Nissan Quest w/Factory Roof Rails		15
		08-13	Toyota Sequoia w/Factory Roof Rails		15
		04-10	Toyota Sienna w/Factory Roof Rails		15
	59712	12-16	KIA Rio 5 Dr. Hatchback, Except w/Factory Roof Rails	10	5
	59713	12-16	Hyundai Accent 5 Dr. Hatchback, Except w/Factory Roof Rails	10	5
		11-14	Mazda 2		5
	59714	12-16	Hyundai Accent 5 Dr. Hatchback, Except w/Factory Roof Rails	10	5
		11-14	Mazda 2		5
		04-13	Mazda 3 4 Dr. Sedan		5

† = Available while supplies last.

ROOF RACK APPLICATION NUMERICAL

PC	PART NO.	YEARS	MAKE/MODEL	WGT LBS	IN
	59714	04-13	Mazda 3 5 Dr. Hatchback	10	5
		07-12	Mazda CX-7 Except w/Factory Roof Rails		5
	59715	12-14	Hyundai Accent 5 Dr. Hatchback, Except w/Factory Roof Rails	11	5
		04-13	Mazda 3 4 Dr. Sedan		5
		04-13	Mazda 3 5 Dr. Hatchback		5
		07-12	Mazda CX-7 Except w/Factory Roof Rails		5
		07-13	Mazda CX-9 Except w/Factory Roof Rails		5
	59719†	07-10	Volkswagen Passat Wagon, w/Factory Roof Rails	8	10
	59721	03-10	Pontiac Vibe Except w/Factory Roof Rails	9	5
		03-10	Toyota Matrix Except w/Factory Roof Rails		5
	59722	03-10	Pontiac Vibe Except w/Factory Roof Rails	11	5
		03-10	Toyota Matrix Except w/Factory Roof Rails		5
	59723	01-13	Toyota Highlander Except w/Factory Roof Rails	12	5
		01-12	Toyota RAV4 Except w/Factory Roof Rails		5
	59724	07-14	Toyota FJ Cruiser Except w/Factory Roof Rails	12	5
		01-13	Toyota Highlander Except w/Factory Roof Rails		5
		01-12	Toyota RAV4 Except w/Factory Roof Rails		5
	59726	12-16	Hyundai Veloster Except w/Factory Roof Rails	11	5
	59728	04-09	Toyota Prius	10	5
	59729	12-17	Toyota Prius V	10	5
	59730	10-15	Hyundai Tucson GL (US Only)	11	5
	59731	09-15	Toyota Venza Except w/Factory Roof Rails	11	5
	59733	07-11	Toyota Camry 4 Dr. Sedan	10	5
	59734	09-13	Toyota Corolla 4 Dr. Sedan	10	5
	59735	12-16	KIA Rio 4 Dr. Sedan	10	5
	59736	10-16	Volkswagen Golf 2 Dr. Hatchback	10	5
		10-16	Volkswagen Golf 3 Dr. Hatchback (Canada Only)		5
		10-16	Volkswagen Golf 4 Dr. Hatchback		5
		10-16	Volkswagen Golf 5 Dr. Hatchback (Canada Only)		5
		12-15	Volkswagen Golf R 2 Dr. Hatchback		5
		12-15	Volkswagen Golf R 4 Dr. Hatchback		5
		12-15	Volkswagen Golf R 5 Dr. Hatchback (Canada Only)		5
		10-15	Volkswagen GTI 2 Dr. Hatchback		5
		10-14	Volkswagen GTI 3 Dr. Hatchback (Canada Only)		5
		10-15	Volkswagen GTI 4 Dr. Hatchback		5
		10-14	Volkswagen GTI 5 Dr. Hatchback (Canada Only)		5
	59737	09-16	Volkswagen CC	10	5
	59738	12-17	Volkswagen Passat 4 Dr. Sedan	10	5
	59740	13-16	Hyundai Elantra GT Except w/Factory Roof Rails	10	5
	59741	13-16	Hyundai Elantra 2 Dr. Coupe, Except w/Factory Roof Rails	10	5
	59752	05-17	Toyota Tacoma 4 Dr. Access Cab, Except w/Factory Roof Rails	10	5
	59753	04-16	Chevrolet Colorado w/Aftermarket Fiberglass Flat Roof Cap or Tonneau	1	30
		94-04	Chevrolet S10 w/Aftermarket Fiberglass Flat Roof Cap or Tonneau		30
		99-07	Chevrolet Silverado 1500 (Classic), w/Aftermarket Fiberglass Flat Roof Cap or Tonneau		30
		01-07	Chevrolet Silverado 1500 HD (Classic), w/Aftermarket Fiberglass Flat Roof Cap or Tonneau		30
		07-17	Chevrolet Silverado 1500 w/Aftermarket Fiberglass Flat Roof Cap or Tonneau		30
		01-07	Chevrolet Silverado 2500 HD (Classic), w/Aftermarket Fiberglass Flat Roof Cap or Tonneau		30
		07-16	Chevrolet Silverado 2500 HD w/Aftermarket Fiberglass Flat Roof Cap or Tonneau		30
		99-04	Chevrolet Silverado 2500 w/Aftermarket Fiberglass Flat Roof Cap or Tonneau		30
		01-07	Chevrolet Silverado 3500 (Classic), w/Aftermarket Fiberglass Flat Roof Cap or Tonneau		30
		07-16	Chevrolet Silverado 3500 HD w/Aftermarket Fiberglass Flat Roof Cap or Tonneau		30
		97-10	Dodge Dakota w/Aftermarket Fiberglass Flat Roof Cap or Tonneau		30
		94-10	Dodge Ram 1500 w/Aftermarket Fiberglass Flat Roof Cap or Tonneau		30
		94-10	Dodge Ram 2500 w/Aftermarket Fiberglass Flat Roof Cap or Tonneau		30
		94-10	Dodge Ram 3500 w/Aftermarket Fiberglass Flat Roof Cap or Tonneau		30
		04-17	Ford F-150 w/Aftermarket Fiberglass Flat Roof Cap or Tonneau		30
		01-11	Ford Ranger w/Aftermarket Fiberglass Flat Roof Cap or Tonneau		30
		04-12	GMC Canyon w/Aftermarket Fiberglass Flat Roof Cap or Tonneau		30
		99-07	GMC Sierra 1500 (Classic), w/Aftermarket Fiberglass Flat Roof Cap or Tonneau		30
		01-07	GMC Sierra 1500 HD (Classic), w/Aftermarket Fiberglass Flat Roof Cap or Tonneau		30

PC	PART NO.	YEARS	MAKE/MODEL	WGT LBS	IN
	59753	07-17	GMC Sierra 1500 w/Aftermarket Fiberglass Flat Roof Cap or Tonneau	1	30
		01-07	GMC Sierra 2500 HD (Classic), w/Aftermarket Fiberglass Flat Roof Cap or Tonneau		30
		07-16	GMC Sierra 2500 HD w/Aftermarket Fiberglass Flat Roof Cap or Tonneau		30
		99-04	GMC Sierra 2500 w/Aftermarket Fiberglass Flat Roof Cap or Tonneau		30
		01-07	GMC Sierra 3500 (Classic), w/Aftermarket Fiberglass Flat Roof Cap or Tonneau		30
		07-16	GMC Sierra 3500 HD w/Aftermarket Fiberglass Flat Roof Cap or Tonneau		30
		94-04	GMC Sonoma w/Aftermarket Fiberglass Flat Roof Cap or Tonneau		30
		05-13	Nissan Frontier w/Aftermarket Fiberglass Flat Roof Cap or Tonneau		30
		04-16	Nissan Titan w/Aftermarket Fiberglass Flat Roof Cap or Tonneau		30
		11-17	RAM 1500 w/Aftermarket Fiberglass Flat Roof Cap or Tonneau		30
		11-17	RAM 2500 w/Aftermarket Fiberglass Flat Roof Cap or Tonneau		30
		11-17	RAM 3500 w/Aftermarket Fiberglass Flat Roof Cap or Tonneau		30
		11	RAM Dakota w/Aftermarket Fiberglass Flat Roof Cap or Tonneau		30
		96-17	Toyota Tacoma w/Aftermarket Fiberglass Flat Roof Cap or Tonneau		30
		00-17	Toyota Tundra w/Aftermarket Fiberglass Flat Roof Cap or Tonneau		30
	59754	04-16	Chevrolet Colorado	1	45
		96-14	Chevrolet Express 1500		45
		96-17	Chevrolet Express 2500		45
		96-17	Chevrolet Express 3500		45
		75-95	Chevrolet G10		45
		71-74	Chevrolet G10 Van		45
		75-95	Chevrolet G20		45
		71-74	Chevrolet G20 Van		45
		75-96	Chevrolet G30		45
		71-74	Chevrolet G30 Van		45
		94-04	Chevrolet S10		45
		07-17	Chevrolet Silverado 1500		45
		99-07	Chevrolet Silverado 1500 (Classic)		45
		01-07	Chevrolet Silverado 1500 HD (Classic)		45
		99-04	Chevrolet Silverado 2500		45
		07-16	Chevrolet Silverado 2500 HD		45
		01-07	Chevrolet Silverado 2500 HD (Classic)		45
		01-07	Chevrolet Silverado 3500 (Classic)		45
		07-16	Chevrolet Silverado 3500 HD		45
		97-10	Dodge Dakota		45
		94-10	Dodge Ram 1500		45
		94-10	Dodge Ram 2500		45
		94-10	Dodge Ram 3500		45
		75-83	Ford E-100 Econoline		45
		75-14	Ford E-150 Econoline		45
		75-14	Ford E-250 Econoline		45
		75-02	Ford E-350 Econoline		45
		03-14	Ford E-350 Econoline Super Duty		45
		04-17	Ford F-150		45
		01-11	Ford Ranger		45
		10-16	Ford Transit Connect		45
		04-12	GMC Canyon		45
		75-78	GMC G15		45
		71-74	GMC G15/G1500 Van		45
		79-95	GMC G1500		45
		75-78	GMC G25		45
		71-74	GMC G25/G2500 Van		45
		79-95	GMC G2500		45
		75-78	GMC G35		45
		71-74	GMC G35/G3500 Van		45
		79-96	GMC G3500		45
		96-14	GMC Savana 1500		45
		96-17	GMC Savana 2500		45
		96-17	GMC Savana 3500		45
		07-17	GMC Sierra 1500		45
		99-07	GMC Sierra 1500 (Classic)		45
		01-07	GMC Sierra 1500 HD (Classic)		45
		99-04	GMC Sierra 2500		45
		07-16	GMC Sierra 2500 HD		45
		01-07	GMC Sierra 2500 HD (Classic)		45
		01-07	GMC Sierra 3500 (Classic)		45
		07-16	GMC Sierra 3500 HD		45

† = Available while supplies last.

ROOF RACK APPLICATION NUMERICAL

PC	PART NO.	YEARS	MAKE/MODEL	WGT LBS	IN
	59754	94-04	GMC Sonoma	1	45
		04-16	Nissan Titan		45
		11-17	RAM 1500		45
		11-17	RAM 2500		45
		11-17	RAM 3500		45
		11	RAM Dakota		45
		96-17	Toyota Tacoma		45
		00-17	Toyota Tundra		45
	59755	07-08	Honda Fit	10	5
	59756	09-13	Honda Fit	10	5
	59757	08-12	Honda Accord Sedan	10	5
	59758	12-15	Honda Civic 4 Dr. Sedan	10	5
	59759	06-11	Honda Civic 4 Dr. Sedan	10	5
	59760	09-15	Honda Pilot Except w/Factory Roof Rails	10	15
	59761	11	BMW 1 Series M	10	5
		12-13	BMW 118i		5
		08-12	BMW 120i		5
		09-13	BMW 125i		5
		08-13	BMW 128i		5
		08-10	BMW 130i		5
		08-11	BMW 135i		5
		13	BMW 135is		5
		14-16	BMW 220i		5
		16	BMW 220i Active Tourer		5
		14-16	BMW 228i		5
		15-16	BMW 228i xDrive		5
		14	BMW 235i		5
		99	BMW 318i		5
		99	BMW 318is		5
		01-05	BMW 320i		5
		00	BMW 323Ci 2 Dr. Coupe		5
		99-11	BMW 323i		5
		99	BMW 323is 2 Dr. Coupe		5
		01-06	BMW 325Ci 2 Dr. Coupe		5
		01-13	BMW 325i		5
		01-06	BMW 325xi 4 Dr. Sedan		5
		00	BMW 328Ci 2 Dr. Coupe		5
		99-14	BMW 328i		5
		09-16	BMW 328i xDrive		5
		99	BMW 328is		5
		07-08	BMW 328xi		5
		01-06	BMW 330Ci 2 Dr. Coupe		5
		01-06	BMW 330i		5
		06	BMW 330xi		5
		01-05	BMW 330xi 4 Dr. Sedan		5
		09-11	BMW 335d 4 Dr. Sedan		5
		07-16	BMW 335i		5
		09-16	BMW 335i xDrive		5
		11-13	BMW 335is 2 Dr. Coupe		5
		07-08	BMW 335xi		5
		16	BMW 420i		5
		14-15	BMW 428i		5
		14-16	BMW 428i xDrive		5
		14-15	BMW 435i		5
		14-16	BMW 435i xDrive		5
		01-13	BMW M3 2 Dr. Coupe		5
		08-09	Saturn Astra 3 Dr. Hatchback, w/Anchor Points		5
		08-09	Saturn Astra 5 Dr. Hatchback, w/Anchor Points		5
	59762	99	BMW 318i	11	5
		99	BMW 318is		5
		01-16	BMW 320i		5
		13-16	BMW 320i xDrive		5
		00	BMW 323Ci 2 Dr. Coupe		5
		99-11	BMW 323i		5
		99	BMW 323is 2 Dr. Coupe		5
		01-06	BMW 325Ci 2 Dr. Coupe		5
		01-13	BMW 325i		5
		01-05	BMW 325xi		5
		06	BMW 325xi 4 Dr. Sedan		5
		00	BMW 328Ci 2 Dr. Coupe		5
		14-16	BMW 328d		5
		14-16	BMW 328d xDrive		5
		99-15	BMW 328i		5
		14-15	BMW 328i GT xDrive		5
		09-16	BMW 328i xDrive		5
		99	BMW 328is		5
		07-08	BMW 328xi		5

PC	PART NO.	YEARS	MAKE/MODEL	WGT LBS	IN
	59762	01-06	BMW 330Ci 2 Dr. Coupe	11	5
		01-16	BMW 330i		5
		06	BMW 330xi		5
		01-05	BMW 330xi 4 Dr. Sedan		5
		09-11	BMW 335d 4 Dr. Sedan		5
		07-15	BMW 335i		5
		14-15	BMW 335i GT xDrive		5
		09-15	BMW 335i xDrive		5
		11-13	BMW 335is 2 Dr. Coupe		5
		07-10	BMW 335xi		5
		16	BMW 340i		5
		16	BMW 340i xDrive		5
		14-16	BMW 520i		5
		01-03	BMW 525i		5
		97-16	BMW 528i		5
		12-16	BMW 528i xDrive		5
		01-13	BMW 530i		5
		14-16	BMW 535d		5
		14-16	BMW 535d xDrive		5
		11-16	BMW 535i		5
		11-16	BMW 535i xDrive		5
		97-03	BMW 540i		5
		11-16	BMW 550i		5
		11-16	BMW 550i xDrive		5
		01-13	BMW M3 2 Dr. Coupe		5
		00-03	BMW M5 4 Dr. Sedan		5
		07	Mercedes-Benz E280 4 Dr. Sedan		5
		08-09	Mercedes-Benz E300 4 Dr. Sedan		5
		03-09	Mercedes-Benz E320 4 Dr. Sedan		5
		06-09	Mercedes-Benz E350 4 Dr. Sedan		5
		03-06	Mercedes-Benz E500 4 Dr. Sedan		5
		03-06	Mercedes-Benz E55 AMG 4 Dr. Sedan		5
		07-09	Mercedes-Benz E550 4 Dr. Sedan		5
		07-09	Mercedes-Benz E63 AMG 4 Dr. Sedan		5
	59763	06-11	BMW 323i	12	5
		06	BMW 325Ci 2 Dr. Coupe		5
		06	BMW 325i		5
		06	BMW 325xi 4 Dr. Sedan		5
		07-14	BMW 328i		5
		09-16	BMW 328i xDrive		5
		07-08	BMW 328xi		5
		06	BMW 330Ci 2 Dr. Coupe		5
		06	BMW 330i		5
		06	BMW 330xi		5
		09-11	BMW 335d 4 Dr. Sedan		5
		07-13	BMW 335i		5
		09-13	BMW 335i xDrive		5
		11-13	BMW 335is 2 Dr. Coupe		5
		07-08	BMW 335xi		5
		01-03	BMW 525i 4 Dr. Sedan		5
		97-00	BMW 528i 4 Dr. Sedan		5
		01-03	BMW 530i 4 Dr. Sedan		5
		97-03	BMW 540i 4 Dr. Sedan		5
		08-13	BMW M3 2 Dr. Coupe		5
		00-03	BMW M5 4 Dr. Sedan		5
		07	Mercedes-Benz E280 4 Dr. Sedan		5
		08-09	Mercedes-Benz E300 4 Dr. Sedan		5
		03-09	Mercedes-Benz E320 4 Dr. Sedan		5
		06-09	Mercedes-Benz E350 4 Dr. Sedan		5
		03-06	Mercedes-Benz E500 4 Dr. Sedan		5
		03-06	Mercedes-Benz E55 AMG 4 Dr. Sedan		5
		07-09	Mercedes-Benz E550 4 Dr. Sedan		5
		07-09	Mercedes-Benz E63 AMG 4 Dr. Sedan		5
	59766	13-17	Hyundai Santa Fe Sport w/Factory Roof Rails, (5 Passenger)	10	5
		13-17	Hyundai Santa Fe w/Factory Roof Rails, (6/7 Passenger)		5
	59767	13-16	Mazda CX-5 Except w/Factory Roof Rails	10	5
	59768	11-16	Ford Fiesta 5 Dr. Hatchback	10	5
	59769	11-16	Ford Fiesta 4 Dr. Sedan	10	5
	59770	07-14	Ford Edge Except w/Factory Roof Rails	10	5
		07-15	Lincoln MKX Except w/Factory Roof Rails		5
	59771	14-17	KIA Forte 4 Dr. Sedan, Except w/Factory Roof Rails	10	15
	59779	13-17	Hyundai Santa Fe Except w/Factory Roof Rails, (6/7 Passenger)	9	15
		13-14	Hyundai Santa Fe Sport, Except w/Factory Roof Rails, (5 Passenger)		15
	59784	14-15	KIA Sorento w/Factory Roof Rails & Panoramic Sunroof	11	5
	59786	10-17	Chevrolet Equinox w/Factory Roof Rails	10	15

† = Available while supplies last.

ROOF RACK APPLICATION NUMERICAL

PC	PART NO.	YEARS	MAKE/MODEL	WGT LBS	IN
	59786	10-17	GMC Terrain w/Factory Roof Rails	10	15
	59788	14-17	KIA Forte 5 Dr. Hatchback, Except w/Factory Roof Rails	10	15
	59789	14-16	KIA Soul w/Anchor Points, Except w/Factory Roof Rails	10	15
	59790	14-16	KIA Soul w/Factory Roof Rails (Canada Only)	11	15
	59800†	09-12	Hyundai Elantra Touring 5 Dr., Except w/Factory Roof Rails	9	15
	59801†	06-11	KIA Rio 4 Dr. Sedan	8	15
		06-11	KIA Rio5 5 Dr. Hatchback	8	15
	59803†	07-10	Hyundai Elantra 4 Dr. Sedan	8	15
	59808†	05-10	KIA Sportage w/Factory Roof Rails	8	15
	59812	09	Mercedes-Benz ML320 BlueTEC 4Matic w/Factory Roof Rails	9	5
		07-08	Mercedes-Benz ML320 CDI w/Factory Roof Rails	5	
		10-11	Mercedes-Benz ML350 BlueTEC 4Matic w/Factory Roof Rails	5	
		06-11	Mercedes-Benz ML350 w/Factory Roof Rails	5	
		10-11	Mercedes-Benz ML450 Hybrid, w/Factory Roof Rails	5	
		06-07	Mercedes-Benz ML500 w/Factory Roof Rails	5	
		08-11	Mercedes-Benz ML550 w/Factory Roof Rails	5	
		07-11	Mercedes-Benz ML63 AMG w/Factory Roof Rails	5	
	59817	10-15	Lexus RX350 w/Factory Roof Rails	8	5
	59818†	10-13	KIA Soul w/Factory Roof Rails	8	15
	59820	10-15	Volkswagen Golf Wagon (Canada Only), w/Factory Roof Rails	8	5
		09-13	Volkswagen Jetta SportWagon w/Factory Roof Rails	5	
		09	Volkswagen Jetta Wagon (Canada Only), w/Factory Roof Rails	5	
	59821	07-12	Mazda CX-7 Except w/Factory Roof Rails	8	15
	59823	09-14	Nissan Murano w/Factory Roof Rails	9	5
	59824	08-16	Nissan Rogue w/Factory Roof Rails	9	5
	59827	04-10	BMW X3 w/Factory Roof Rails	8	15
	59828	00-06	BMW X5 w/Factory Roof Rails	8	15
	59829	07-10	BMW X5 w/Factory Roof Rails	8	15
	59830	11-14	Mazda 2	8	5
	59832	10-13	Mazda 3 4 Dr. Sedan	8	10
	59833	10-13	Mazda 3 5 Dr. Hatchback	8	10
	59834	06-16	Mazda 5	10	10
		10-17	Mitsubishi Lancer 5 Dr. Hatchback, Except w/Factory Roof Rails	10	
		07-17	Mitsubishi Outlander Except w/Factory Roof Rails	10	
		11-16	Mitsubishi Outlander Sport Except w/Factory Roof Rails	10	
	59839	10-13	KIA Forte 4 Dr. Sedan, Except w/Factory Roof Rails	10	15
	59842	10-13	KIA Soul Except w/Factory Roof Rails	10	15
	59849	11-16	KIA Sportage w/Factory Roof Rails	11	5
	59853	04-16	Chevrolet Colorado	2	60
		96-14	Chevrolet Express 1500	60	
		96-17	Chevrolet Express 2500	60	
		96-17	Chevrolet Express 3500	60	
		75-95	Chevrolet G10	60	
		71-74	Chevrolet G10 Van	60	
		75-95	Chevrolet G20	60	
		71-74	Chevrolet G20 Van	60	
		75-96	Chevrolet G30	60	
		71-74	Chevrolet G30 Van	60	
		94-04	Chevrolet S10	60	
		07-17	Chevrolet Silverado 1500	60	
		99-07	Chevrolet Silverado 1500 (Classic)	60	
		01-07	Chevrolet Silverado 1500 HD (Classic)	60	
		99-04	Chevrolet Silverado 2500	60	
		07-16	Chevrolet Silverado 2500 HD	60	
		01-07	Chevrolet Silverado 2500 HD (Classic)	60	
		01-07	Chevrolet Silverado 3500 (Classic)	60	
		07-16	Chevrolet Silverado 3500 HD	60	
		97-10	Dodge Dakota	60	
		94-10	Dodge Ram 1500	60	
		94-10	Dodge Ram 2500	60	
		94-10	Dodge Ram 3500	60	
		75-83	Ford E-100 Econoline	60	
		75-14	Ford E-150 Econoline	60	
		75-14	Ford E-250 Econoline	60	
		75-02	Ford E-350 Econoline	60	
		03-14	Ford E-350 Econoline Super Duty	60	
		04-17	Ford F-150	60	
		01-11	Ford Ranger	60	
		10-16	Ford Transit Connect	60	
		14-17	Ford Transit-150	60	
		14-17	Ford Transit-250	60	
		14-17	Ford Transit-350	60	
		04-12	GMC Canyon	60	
		75-78	GMC G15	60	
		71-74	GMC G15/G1500 Van	60	
		79-95	GMC G1500	60	

PC	PART NO.	YEARS	MAKE/MODEL	WGT LBS	IN
	59853	75-78	GMC G25	2	60
		71-74	GMC G25/G2500 Van	60	
		79-95	GMC G2500	60	
		75-78	GMC G35	60	
		71-74	GMC G35/G3500 Van	60	
		79-96	GMC G3500	60	
		96-14	GMC Savana 1500	60	
		96-17	GMC Savana 2500	60	
		96-17	GMC Savana 3500	60	
		07-17	GMC Sierra 1500	60	
		99-07	GMC Sierra 1500 (Classic)	60	
		01-07	GMC Sierra 1500 HD (Classic)	60	
		99-04	GMC Sierra 2500	60	
		07-16	GMC Sierra 2500 HD	60	
		01-07	GMC Sierra 2500 HD (Classic)	60	
		01-07	GMC Sierra 3500 (Classic)	60	
		07-16	GMC Sierra 3500 HD	60	
		94-04	GMC Sonoma	60	
		04-16	Nissan Titan	60	
		11-17	RAM 1500	60	
		11-17	RAM 2500	60	
		11-17	RAM 3500	60	
		11	RAM Dakota	60	
		96-17	Toyota Tacoma	60	
		00-17	Toyota Tundra	60	
	59854	96-14	Chevrolet Express 1500	3	60
		96-17	Chevrolet Express 2500	60	
		96-17	Chevrolet Express 3500	60	
		75-95	Chevrolet G10	60	
		71-74	Chevrolet G10 Van	60	
		75-95	Chevrolet G20	60	
		71-74	Chevrolet G20 Van	60	
		75-96	Chevrolet G30	60	
		71-74	Chevrolet G30 Van	60	
		75-83	Ford E-100 Econoline	60	
		75-14	Ford E-150 Econoline	60	
		75-14	Ford E-250 Econoline	60	
		75-02	Ford E-350 Econoline	60	
		03-14	Ford E-350 Econoline Super Duty	60	
		10-16	Ford Transit Connect	60	
		75-78	GMC G15	60	
		71-74	GMC G15/G1500 Van	60	
		79-95	GMC G1500	60	
		75-78	GMC G25	60	
		71-74	GMC G25/G2500 Van	60	
		79-95	GMC G2500	60	
		75-78	GMC G35	60	
		71-74	GMC G35/G3500 Van	60	
		79-96	GMC G3500	60	
		96-14	GMC Savana 1500	60	
		96-17	GMC Savana 2500	60	
		96-17	GMC Savana 3500	60	
	59855	04-16	Chevrolet Colorado w/Aftermarket Fiberglass Flat Roof Cap or Tonneau	3	40
		94-04	Chevrolet S10 w/Aftermarket Fiberglass Flat Roof Cap or Tonneau	40	
		99-07	Chevrolet Silverado 1500 (Classic), w/Aftermarket Fiberglass Flat Roof Cap or Tonneau	40	
		01-07	Chevrolet Silverado 1500 HD (Classic), w/Aftermarket Fiberglass Flat Roof Cap or Tonneau	40	
		07-17	Chevrolet Silverado 1500 w/Aftermarket Fiberglass Flat Roof Cap or Tonneau	40	
		01-07	Chevrolet Silverado 2500 HD (Classic), w/Aftermarket Fiberglass Flat Roof Cap or Tonneau	40	
		07-16	Chevrolet Silverado 2500 HD w/Aftermarket Fiberglass Flat Roof Cap or Tonneau	40	
		99-04	Chevrolet Silverado 2500 w/Aftermarket Fiberglass Flat Roof Cap or Tonneau	40	
		01-07	Chevrolet Silverado 3500 (Classic), w/Aftermarket Fiberglass Flat Roof Cap or Tonneau	40	
		07-16	Chevrolet Silverado 3500 HD w/Aftermarket Fiberglass Flat Roof Cap or Tonneau	40	
		97-10	Dodge Dakota w/Aftermarket Fiberglass Flat Roof Cap or Tonneau	40	
		94-10	Dodge Ram 1500 w/Aftermarket Fiberglass Flat Roof Cap or Tonneau	40	

† = Available while supplies last.

ROOF RACK APPLICATION NUMERICAL

PC	PART NO.	YEARS	MAKE/MODEL	WGT LBS	IN
	59855	94-10	Dodge Ram 2500 w/Aftermarket Fiberglass Flat Roof Cap or Tonneau	3	40
		94-10	Dodge Ram 3500 w/Aftermarket Fiberglass Flat Roof Cap or Tonneau		40
		04-17	Ford F-150 w/Aftermarket Fiberglass Flat Roof Cap or Tonneau		40
		01-11	Ford Ranger w/Aftermarket Fiberglass Flat Roof Cap or Tonneau		40
		04-12	GMC Canyon w/Aftermarket Fiberglass Flat Roof Cap or Tonneau		40
		99-07	GMC Sierra 1500 (Classic), w/Aftermarket Fiberglass Flat Roof Cap or Tonneau		40
		01-07	GMC Sierra 1500 HD (Classic), w/Aftermarket Fiberglass Flat Roof Cap or Tonneau		40
		07-17	GMC Sierra 1500 w/Aftermarket Fiberglass Flat Roof Cap or Tonneau		40
		01-07	GMC Sierra 2500 HD (Classic), w/Aftermarket Fiberglass Flat Roof Cap or Tonneau		40
		07-16	GMC Sierra 2500 HD w/Aftermarket Fiberglass Flat Roof Cap or Tonneau		40
		99-04	GMC Sierra 2500 w/Aftermarket Fiberglass Flat Roof Cap or Tonneau		40
		01-07	GMC Sierra 3500 (Classic), w/Aftermarket Fiberglass Flat Roof Cap or Tonneau		40
		07-16	GMC Sierra 3500 HD w/Aftermarket Fiberglass Flat Roof Cap or Tonneau		40
		94-04	GMC Sonoma w/Aftermarket Fiberglass Flat Roof Cap or Tonneau		40
		05-13	Nissan Frontier w/Aftermarket Fiberglass Flat Roof Cap or Tonneau		40
		04-16	Nissan Titan w/Aftermarket Fiberglass Flat Roof Cap or Tonneau		40
		11-17	RAM 1500 w/Aftermarket Fiberglass Flat Roof Cap or Tonneau		40
		11-17	RAM 2500 w/Aftermarket Fiberglass Flat Roof Cap or Tonneau		40
		11-17	RAM 3500 w/Aftermarket Fiberglass Flat Roof Cap or Tonneau		40
		11	RAM Dakota w/Aftermarket Fiberglass Flat Roof Cap or Tonneau		40
		96-17	Toyota Tacoma w/Aftermarket Fiberglass Flat Roof Cap or Tonneau		40
		00-17	Toyota Tundra w/Aftermarket Fiberglass Flat Roof Cap or Tonneau		40
	59866	11-14	Hyundai Sonata Except w/Factory Roof Rails	10	15
	59867	11-16	Hyundai Elantra 4 Dr. Sedan, Except w/Factory Roof Rails	10	15
	59868	11-15	KIA Sorento w/Factory Roof Rails & No Panoramic Sunroof	9	15
	59869	11-13	KIA Sorento w/Factory Roof Rails & Panoramic Sunroof	9	15
	59870	10-15	Hyundai Tucson w/Factory Roof Rails	9	15
	59871	10-14	KIA Sedona w/Factory Roof Rails	8	15
	59884	12-16	Hyundai Accent 4 Dr. Sedan, Except w/Factory Roof Rails	10	15
	59893	10-16	Cadillac SRX w/Factory Roof Rails	9	5
	59896	11-15	KIA Optima Except w/Factory Roof Rails	8	15
	59897	02-04	Audi A4 Quattro Avant Wagon, w/Factory Roof Rails	12	15
		08-10	Chevrolet HHR SS w/Factory Roof Rails		15
		06-11	Chevrolet HHR w/Factory Roof Rails		15
		13-16	Chevrolet Spark w/Factory Roof Rails		15
		08-12	Ford Escape w/Factory Roof Rails		15
		02-05	Ford Explorer 4 Dr., w/Factory Roof Rails		15
		04-07	Ford Freestar w/Factory Roof Rails		15
		09-12	Hyundai Elantra Touring 5 Dr., w/Factory Roof Rails		15
		96-00	Hyundai Elantra Wagon, w/Factory Roof Rails		15
		08-12	Infiniti EX35 w/Factory Roof Rails		15
		03-05	Lincoln Aviator w/Factory Roof Rails		15
		00-06	Mazda MPV w/Factory Roof Rails		15
		08-11	Mercury Mariner w/Factory Roof Rails		15
		04-07	Mercury Monterey w/Factory Roof Rails		15
		08-10	MINI Cooper Clubman w/Factory Roof Rails		15
		03-10	Pontiac Vibe w/Factory Roof Rails		15
		95-99	Subaru Legacy Wagon, w/Factory Roof Rails		15
		00-09	Subaru Outback Wagon, w/Factory Roof Rails, Except Sport		15
		98-02	Suzuki Esteem Wagon, w/Factory Roof Rails		15
		05-08	Suzuki Foreza Wagon, w/Factory Roof Rails		15
		99-05	Suzuki Grand Vitara w/Factory Roof Rails		15
		07-14	Suzuki SX4 Crossover, w/Factory Roof Rails		15
		99-04	Suzuki Vitara 4 Dr., w/Factory Roof Rails		15
		02-06	Suzuki XL-7 w/Factory Roof Rails		15
		03-10	Toyota Matrix w/Factory Roof Rails		15
		10-15	Volkswagen Golf Wagon (Canada Only), w/Factory Roof Rails		15
		09-13	Volkswagen Jetta SportWagon w/Factory Roof Rails		15
		09	Volkswagen Jetta Wagon (Canada Only), w/Factory Roof Rails		15
		01-06	Volkswagen Jetta Wagon, w/Factory Roof Rails		15
		90-10	Volkswagen Passat Wagon, w/Factory Roof Rails		15
		03-14	Volvo XC90 w/Factory Roof Rails		15

PC	PART NO.	YEARS	MAKE/MODEL	WGT LBS	IN
	59898	11-14	Acura TSX Sport Wagon, w/Factory Roof Rails	12	15
		98-08	Audi A4 Quattro Avant Wagon, w/Factory Roof Rails		15
		00	BMW 323i Sports Wagon w/Factory Roof Rails		15
		01-05	BMW 325i Sports Wagon w/Factory Roof Rails		15
		01-05	BMW 325xi Sports Wagon w/Factory Roof Rails		15
		07-12	BMW 328i Sports Wagon w/Factory Roof Rails		15
		07-08	BMW 328xi Sports Wagon w/Factory Roof Rails		15
		01-03	BMW 525i Sports Wagon w/Factory Roof Rails		15
		00	BMW 528i Sports Wagon w/Factory Roof Rails		15
		06-07	BMW 530xi Sports Wagon w/Factory Roof Rails		15
		08	BMW 535xi Sports Wagon w/Factory Roof Rails		15
		99-03	BMW 540i Sports Wagon w/Factory Roof Rails		15
		06-07	Buick Rainier w/Factory Roof Rails		15
		04-16	Cadillac SRX w/Factory Roof Rails		15
		95-04	Chevrolet Blazer Downsize, w/Factory Roof Rails		15
		99-01	Chevrolet Blazer Trailblazer w/Factory Roof Rails		15
		08-15	Chevrolet Captiva Sport w/Factory Roof Rails		15
		13-16	Chevrolet Trax w/Factory Roof Rails		15
		97-05	Chevrolet Venture w/Factory Roof Rails		15
		07-09	Chrysler Aspen w/Factory Roof Rails		15
		04-09	Dodge Durango w/Factory Roof Rails		15
		09-15	Dodge Journey w/Factory Raised Roof Rails		15
		08-16	Ford Escape w/Factory Roof Rails		15
		02-05	Ford Explorer 4 Dr., w/Factory Roof Rails		15
		04-07	Ford Freestar w/Factory Roof Rails		15
		02	GMC Jimmy Downsize, w/Factory Roof Rails		15
		99-13	Honda Odyssey w/Factory Roof Rails		15
		03-08	Honda Pilot w/Factory Roof Rails		15
		09-12	Hyundai Elantra Touring 5 Dr., w/Factory Roof Rails		15
		96-00	Hyundai Elantra Wagon, w/Factory Roof Rails		15
		01-06	Hyundai Santa Fe w/Factory Roof Rails		15
		05-15	Hyundai Tucson w/Factory Roof Rails		15
		07-12	Hyundai Veracruz w/Factory Roof Rails		15
		03-12	Infiniti FX35 w/Factory Roof Rails		15
		03-08	Infiniti FX45 w/Factory Roof Rails		15
		09-13	Infiniti FX50 w/Factory Roof Rails		15
		14-16	Infiniti QX50 w/Factory Roof Rails		15
		14-17	Infiniti QX60 w/Factory Roof Rails		15
		14-16	Infiniti QX70 w/Factory Roof Rails		15
		99-04	Jeep Grand Cherokee w/Factory Roof Rails		15
		02-07	Jeep Liberty w/Factory Roof Rails		15
		09-11	KIA Borrego w/Factory Roof Rails		15
		06-14	KIA Sedona w/Factory Roof Rails		15
		03-13	KIA Sorento w/Factory Roof Rails		15
		05-10	KIA Sportage w/Factory Roof Rails		15
		03-09	Lexus GX470 w/Factory Roof Rails		15
		04-06	Lexus RX330 w/Factory Roof Rails		15
		07-15	Lexus RX350 w/Factory Roof Rails		15
		06-08	Lexus RX400h Hybrid, w/Factory Roof Rails		15
		10-12	Lexus RX450h Hybrid, w/Factory Roof Rails		15
		03-05	Lincoln Aviator w/Factory Roof Rails		15
		98-06	Lincoln Navigator w/Factory Roof Rails		15
		10-15	Mercedes-Benz GLK350 w/Factory Roof Rails		15
		08-11	Mercury Mariner w/Factory Roof Rails		15
		04-07	Mercury Monterey w/Factory Roof Rails		15
		03-14	Nissan Murano w/Factory Roof Rails		15
		08-16	Nissan Rogue w/Factory Roof Rails		15
		97-04	Oldsmobile Silhouette w/Factory Roof Rails		15
		05-06	Pontiac Montana SV6 w/Factory Roof Rails		15
		07-09	Pontiac Montana SV6 w/Factory Roof Rails (Canada Only)		15
		99-05	Pontiac Montana w/Factory Roof Rails		15
		97-98	Pontiac Trans Sport w/Factory Roof Rails		15
		03-10	Pontiac Vibe w/Factory Roof Rails		15
		03-16	Porsche Cayenne w/Factory Roof Rails		15
		99-09	Saab 9-5 Wagon, w/Factory Roof Rails		15
		05-09	Saab 9-7X w/Factory Roof Rails		15
		00	Saturn LW1 Wagon, w/Factory Roof Rails		15
		00	Saturn LW2 Wagon, w/Factory Roof Rails		15
		01-03	Saturn LW200 Wagon, w/Factory Roof Rails		15
		01-03	Saturn LW300 Wagon, w/Factory Roof Rails		15
		08-09	Saturn Vue w/Factory Roof Rails		15
		16	Subaru Crosstrek w/Factory Roof Rails		15
		09-13	Subaru Forester w/Factory Roof Rails		15
		13-15	Subaru XV Crosstrek w/Factory Roof Rails		15
		07-14	Suzuki SX4 Crossover, w/Factory Roof Rails		15
		02-06	Suzuki XL-7 w/Factory Roof Rails		15
		03-16	Toyota 4Runner w/Factory Roof Rails		15

TRUCK BED RACK APPLICATION NUMERICAL

PC	PART NO.	YEARS	MAKE/MODEL	WGT LBS	IN				
59898		07-14	Toyota FI Cruiser w/Factory Roof Rails	12	15				
		03-10	Toyota Matrix w/Factory Roof Rails						
		01-17	Toyota RAV4 w/Factory Roof Rails						
		11-17	Toyota Sienna w/Factory Roof Rails						
		10-15	Volkswagen Golf Wagon (Canada Only), w/Factory Roof Rails						
		09-13	Volkswagen Jetta SportWagon w/Factory Roof Rails						
		09	Volkswagen Jetta Wagon (Canada Only), w/Factory Roof Rails						
		01-06	Volkswagen Jetta Wagon, w/Factory Roof Rails						
		09-16	Volkswagen Tiguan w/Factory Roof Rails						
		04-17	Volkswagen Touareg w/Factory Roof Rails						
		05-11	Volvo V50 Wagon, w/Factory Roof Rails						
		01-10	Volvo V70 Wagon, w/Factory Roof Rails						
		03-14	Volvo XC70 Wagon, AWD, w/Factory Roof Rails						
		03-14	Volvo XC90 w/Factory Roof Rails						
		59899				07-13	Acura MDX w/Factory Roof Rails	13	15
						11-16	Acura RDX w/Factory Roof Rails		
						04-10	BMW X3 w/Factory Roof Rails		
						00-10	BMW X5 w/Factory Roof Rails		
						04-13	Cadillac SRX w/Factory Roof Rails		
						07-13	Chevrolet Avalanche w/Factory Roof Rails		
						00-14	Chevrolet Suburban 1500 w/Factory Roof Rails		
						92-99	Chevrolet Suburban C1500 w/Factory Roof Rails		
						92-99	Chevrolet Suburban C2500 w/Factory Roof Rails		
						92-99	Chevrolet Suburban K1500 w/Factory Roof Rails		
92-99	Chevrolet Suburban K2500 w/Factory Roof Rails								
95-14	Chevrolet Tahoe w/Factory Roof Rails								
98-04	Chevrolet Tracker w/Factory Roof Rails								
05-08	Chevrolet Uplander w/Factory Roof Rails								
09	Chevrolet Uplander w/Factory Roof Rails (Canada Only)								
97-05	Chevrolet Venture w/Factory Roof Rails								
07-09	Chrysler Aspen w/Factory Roof Rails								
04-09	Dodge Durango w/Factory Roof Rails								
09-15	Dodge Journey w/Factory Raised Roof Rails								
07-14	Ford Edge w/Factory Roof Rails								
13-16	Ford Escape w/Factory Roof Rails								
01-03	Ford Explorer 2 Dr. Sport, w/Factory Roof Rails								
01-05	Ford Explorer Sport Trac w/Factory Roof Rails								
05-07	Ford Freestyle w/Factory Roof Rails								
00-14	GMC Yukon w/Amber Turn Signals								
92-00	GMC Yukon w/Factory Roof Rails								
00-14	GMC Yukon XL 1500 w/Factory Roof Rails								
00-13	GMC Yukon XL 2500 w/Factory Roof Rails								
99-13	Honda Odyssey w/Factory Roof Rails								
98-02	Honda Passport w/Factory Roof Rails								
03-13	Honda Pilot w/Factory Roof Rails								
01-06	Hyundai Santa Fe w/Factory Roof Rails								
05-15	Hyundai Tucson w/Factory Roof Rails								
07-12	Hyundai Veracruz w/Factory Roof Rails								
98-04	Isuzu Rodeo w/Factory Roof Rails								
05-10	Jeep Grand Cherokee w/Factory Roof Rails								
02-12	Jeep Liberty w/Factory Roof Rails								
08-17	Jeep Patriot w/Factory Roof Rails								
09-11	KIA Borrego w/Factory Roof Rails								
06-12	KIA Sedona w/Factory Roof Rails								
03-13	KIA Sorento w/Factory Roof Rails								
05-10	KIA Sportage w/Factory Roof Rails								
03-09	Lexus GX470 w/Factory Roof Rails								
07-15	Lincoln MKX w/Factory Roof Rails								
04-07	Mazda 6 Sport Wagon w/Factory Roof Rails								
07-16	Mazda CX-9 w/Factory Roof Rails								
08-11	Mazda Tribute w/Factory Roof Rails								
03-05	Mercedes-Benz C240 Wagon, w/Factory Roof Rails								
02-04	Mercedes-Benz C320 Wagon, w/Factory Roof Rails								
98-05	Mercedes-Benz E320 Wagon, w/Factory Roof Rails								
06-11	Mercedes-Benz E350 Wagon, w/Factory Roof Rails								
04-06	Mercedes-Benz E500 Wagon, w/Factory Roof Rails								
06	Mercedes-Benz E55 AMG Wagon, w/Factory Roof Rails								
07-08	Mercedes-Benz E63 AMG Wagon, w/Factory Roof Rails								
09	Mercedes-Benz GL320 BlueTEC 4Matic w/Factory Roof Rails								
07-08	Mercedes-Benz GL320 CDI w/Factory Roof Rails								
10-15	Mercedes-Benz GL350 BlueTEC 4Matic w/Factory Roof Rails								
07-16	Mercedes-Benz GL450 w/Factory Roof Rails								
08-15	Mercedes-Benz GL550 w/Factory Roof Rails								
10-15	Mercedes-Benz GLK350 w/Factory Roof Rails								
09	Mercedes-Benz ML320 BlueTEC 4Matic w/Factory Roof Rails								
07-08	Mercedes-Benz ML320 CDI w/Factory Roof Rails								
98-02	Mercedes-Benz ML320 w/Factory Roof Rails								

PC	PART NO.	YEARS	MAKE/MODEL	WGT LBS	IN
59899		10-14	Mercedes-Benz ML350 BlueTEC 4Matic w/Factory Roof Rails	13	15
		03-15	Mercedes-Benz ML350 w/Factory Roof Rails		
		99-01	Mercedes-Benz ML430 w/Factory Roof Rails		
		10-11	Mercedes-Benz ML450 Hybrid, w/Factory Roof Rails		
		02-07	Mercedes-Benz ML500 w/Factory Roof Rails		
		08-15	Mercedes-Benz ML550 w/Factory Roof Rails		
		07-15	Mercedes-Benz ML63 AMG w/Factory Roof Rails		
		07-12	Mitsubishi Outlander w/Factory Roof Rails (Except Outlander Sport)		
		03-14	Nissan Murano w/Factory Roof Rails		
		13-16	Nissan Pathfinder w/Factory Roof Rails		
		04-16	Nissan Quest w/Factory Roof Rails		
		97-04	Oldsmobile Silhouette w/Factory Roof Rails		
		05-06	Pontiac Montana SV6 w/Factory Roof Rails		
		07-09	Pontiac Montana SV6 w/Factory Roof Rails (Canada Only)		
		99-05	Pontiac Montana w/Factory Roof Rails		
		97-98	Pontiac Trans Sport w/Factory Roof Rails		
		00	Saturn LW1 Wagon, w/Factory Roof Rails		
		00	Saturn LW2 Wagon, w/Factory Roof Rails		
		01-03	Saturn LW200 Wagon, w/Factory Roof Rails		
		01-03	Saturn LW300 Wagon, w/Factory Roof Rails		
		09-13	Subaru Forester w/Factory Roof Rails		
		08-14	Subaru Tribeca w/Factory Roof Rails		
		13	Subaru XV Crosstrek w/Factory Roof Rails		
		03-16	Toyota 4Runner w/Factory Roof Rails		
07-14	Toyota FI Cruiser w/Factory Roof Rails				
01-13	Toyota Highlander w/Factory Roof Rails				
01-12	Toyota RAV4 w/Factory Roof Rails				
04-17	Toyota Sienna w/Factory Roof Rails				
59966	11-17	Jeep Grand Cherokee	10	10	
59967	11-17	Jeep Grand Cherokee	9	10	
59968	10-13	Ford Transit Connect Except w/Factory Roof Rails, With Roof Anchor Points	10	15	
TRUCK BED RACKS					
59742		04-16	Chevrolet Colorado	59	40
		94-04	Chevrolet S10		
		07-17	Chevrolet Silverado 1500		
		99-07	Chevrolet Silverado 1500 (Classic)		
		01-07	Chevrolet Silverado 1500 HD (Classic)		
		99-04	Chevrolet Silverado 2500		
		07-16	Chevrolet Silverado 2500 HD		
		01-07	Chevrolet Silverado 2500 HD (Classic)		
		01-07	Chevrolet Silverado 3500 (Classic)		
		07-16	Chevrolet Silverado 3500 HD		
		97-10	Dodge Dakota		
		94-10	Dodge Ram 1500		
		94-10	Dodge Ram 2500		
		94-10	Dodge Ram 3500		
		04-17	Ford F-150 Except Flareside		
		01-11	Ford Ranger		
		04-12	GMC Canyon		
		07-17	GMC Sierra 1500		
		99-07	GMC Sierra 1500 (Classic)		
		01-07	GMC Sierra 1500 HD (Classic)		
		99-04	GMC Sierra 2500		
		07-16	GMC Sierra 2500 HD		
		01-07	GMC Sierra 2500 HD (Classic)		
		01-07	GMC Sierra 3500 (Classic)		
07-16	GMC Sierra 3500 HD				
94-04	GMC Sonoma				
11-17	RAM 1500 Except w/RamBox Cargo Management System				
11-17	RAM 2500 Except w/RamBox Cargo Management System				
11-16	RAM 3500 Except w/RamBox Cargo Management System				
11	RAM Dakota				
00-17	Toyota Tundra Except w/Integrated Deck Rail Systems				
59799	04-16	Nissan Titan w/Factory Bed Channel System (Deck Rail System)	44	40	
	05-17	Toyota Tacoma w/Factory Bed Channel System (Deck Rail System)		40	

PRODUCT NUMERICAL

PART NO.	DESCRIPTION	PAGE NO.
000612	Bearing Protector, 2" Hub	M-19
001501	Grease Cap, 1.786" Zinc Plated	M-20
001503	Grease Cap, 1.786" Zinc Plated	M-20
001505	Grease Cap, 1.988" Zinc Plated	M-20
001515	Grease Cap, 2.567" Zinc Plated	M-20
001520	Grease Cap, 2.446" Zinc Plated	M-20
001521	Grease Cap, 1.988" Zinc Plated	M-20
001523	Grease Cap, 1.943"	M-20
001524	Grease Cap, 1.943"	M-20
001526	Grease Cap, 2.722"	M-20
001528	Grease Cap, 3.358"	M-20
001531	Grease Cap, 3.157"	M-20
001601	Grease Cap, 2.333"	M-20
001602	Grease Cap, 3.255"	M-20
001603	Grease Cap, 3.882"	M-20
001604	Grease Cap, 2.446"	M-20
001605	Grease Cap, 2.722"	M-20
001606	Grease Cap, 2.503" Plain	M-20
001607	Grease Cap, 3.155"	M-20
001609	Grease Cap, 3.125"	M-20
002120	4-Flat Trailer End Connector, 20' Wunside Harness, 3' Ground	C-15
002125	4-Flat Trailer End Connector, 25' Wunside Harness, 3' Ground	C-15
002130	4-Flat Trailer End Connector, 30' Wunside Harness, 3' Ground	C-15
002215	4-Flat Trailer End Connector, 15' Wishbone Harness, 3' Ground	C-15
002220	4-Flat Trailer End Connector, 20' Wishbone Harness, 3' Ground	C-15, K-7, K-8, K-15, K-18, K-20
002230	4-Flat Trailer End Connector, 30' Wishbone Harness, 3' Ground	C-15
002235	4-Flat Trailer End Connector, 35' Wishbone Harness, 3' Ground	C-15
002240	4-Flat Trailer End Connector, 40' Wishbone Harness, 3' Ground	C-15
002275	5-Flat Trailer End Connector, 25' Wishbone Harness, 4' Groun...	C-19
002280	5-Flat Trailer End Connector, 30' Wishbone Harness, 4' Groun...	C-19
002285	5-Flat Trailer End Connector, 35' Wishbone Harness, 4' Groun...	C-19
002290	5-Flat Trailer End Connector, 40' Wishbone Harness, 4' Groun...	C-19
002301	4-Flat Car End Connector 48" Long, 18" Ground	C-15, K-7, K-8, K-15, K-18, K-20
002309	5-Flat Car End Connector, 6' Long, 6' Ground, 6' Auxiliary	C-19
002401	4-Flat Trailer End Connector, 18" Wunside Harness, 18" Ground	C-15
002402	4-Flat Trailer End Connector, 18" Wishbone Harness, 18" Ground	C-15
002408	Ag Economy Extension Harness, 5' Long	L-7
002409	5-Flat Trailer End Connector, 4' Wishbone Harness, 4' Ground...	C-19
002410	Ag Economy Extension Harness, 10' Long	L-7
002415	Ag Straight Section Harness w/ 7-Pin Ag Plug and 4-Flat, 15' ...	L-7
002425	Ag Straight Section Harness w/ 7-Pin Ag Plug and 4-Flat, 25' ...	L-7
002430	Ag Straight Section Harness w/ 7-Pin Ag Plug and 4-Flat, 30' ...	L-7
002435	Ag Harness Extension, 35' Long	L-7
002478	7-Way Molded Trailer End w/ 8' Cable	C-2, C-22, L-2
002500	Ag Tandem Haul Adapter	L-7
002504	Ag Economy Rear Wishbone Harness, 10' Long	L-7
002505	Ag Economy Rear Wishbone Harness, 15' Long	L-7
002510	Ag Heavy-Duty Wishbone Harness w/Protective Covering, 10' Long	L-7
002515	Ag Heavy-Duty Rear Wishbone Harness w/Protective Covering, 1...	L-7
002590	Replacement Part, Magnet Kit for Ag Lights, 90 lbs. Pull (Se...	L-3, L-5, L-7
002625	Ag Tandem Haul Kit	L-7
002670	Ag Economy Light Kit	L-4
002675	Ag Deluxe Transport Kit w/ Brake Light Function, 6-Pin	L-2, L-5
002676	Ag Deluxe Transport Kit w/ Brake Light Function, 7-Pin	L-5
002802	Metal Wire Clip (1000 pack)	C-35
002805	Wire Nut, Large - 14-16 Gauge (1000 pack)	C-35
002806	Wire Tap, White, Double Leads (500 pack)	C-35
002807	Wire Tap, Blue, Single Leads (500 pack)	C-35
003101	Side Marker/Clearance Light Amber w/Reflex Lens w/Black Stud...	K-18, K-33
003103	Side Marker/Clearance Light Red w/Reflex Lens w/Black Stud-M...	K-33
003121	Side Marker/Clearance Light Amber w/Reflex Lens w/Black Ear...	K-33
003123	Side Marker/Clearance Light Red w/Reflex Lens w/Black Ear-Mo...	K-33
0031350300	A-Frame Bottom Support Plate, 2.3" Hole Dia., for 150's, 160...	J-8, J-27
0031550300	Weld-On Female Mount, 3/4" Pin for 190's	J-8
003201	License Plate Bracket, Plastic, Black	K-7, K-8, K-15, K-18, K-20, K-39
003211	License Plate Bracket, Plastic, Black	K-7, K-8, K-15, K-18, K-20, K-39
003213	License Plate Bracket, Plastic, White	K-39
003225	Side Marker/Clearance Light Amber, PC Rated	K-34
003230	Side Marker/Clearance Light Amber w/White Stud-Mount Base, P...	K-31
003231	Side Marker/Clearance Light Red w/White Stud-Mount Base, PC ...	K-31
003232	Courtesy Light w/Self-Grounding Stud Mount, Single Wire w/Mo...	K-22

PART NO.	DESCRIPTION	PAGE NO.
003238	Side Marker/Clearance Light, Amber, Waterproof, Black, Stud ...	K-31
003239	Side Marker/Clearance Light, Red, Waterproof, Black, Stud Mo...	K-31
003272	Side Marker/Clearance Light Amber w/White Ear-Mount Base, PC...	K-31
003273	Side Marker/Clearance Light Red w/White Ear-Mount Base, PC R...	K-31
003305	ID Bar-SS, Waterproof (w/White Bases), Red	K-38
003306	ID Bar-SS, Waterproof (w/Black Bases), Red	K-38
003327	Replacement Part, Clearance Light Lens Red	K-33
003328	Replacement Part, Clearance Light Lens Amber	K-20, K-33
003330	Replacement Part, Clearance Light Lens Amber	K-34
003337	Replacement Part, Lens, Red, Side Marker/Clearance Light w/S...	K-33
003338	Replacement Part, Lens, Amber, Side Marker/Clearance Light w...	K-20, K-33
003340	Replacement Part, Lens, Amber, Side Marker/Clearance, Square	K-34
003357	Amber Reflector w/Adhesive Back (1/bag)	K-41
003358	Red Reflector w/Adhesive Back (1/bag)	K-41
003387	White Reflector w/Adhesive Back, 1"x1" (2/bag)	K-41
003388	Red Reflector w/Adhesive Back, 1"x1" (2/bag)	K-41
003440	Side Marker/Clearance Light, Amber, w/Dual Bulbs	K-35
003441	Side Marker/Clearance Light, Red, w/Dual Bulbs	K-35
003494	Replacement Part, Lens Amber, Clearance Light	K-35
003495	Replacement Part, Lens Red, Clearance Light	K-35
0050050300	Weld-On Male Mount, 9/16" Pin	J-8
0050240300	Weld-On Female Tube Mount, 5/8" Pin for 190's	J-8
005122	Weld-On Tube Mount for #182524 & #182374	J-8, J-16
006504	Taillight 8-Function, Waterproof Over 80" Low Profile w/Stri...	K-18
006554	Taillight 7-Function, Waterproof Over 80" Low Profile w/Stri...	K-18
007257	7-Way Blade to 5-Flat, 6" Wire Adapter	C-28
007509	Trailer Light Kit w/25' Harness, Waterproof Low-Profile Wrap...	K-18
007539	Trailer Light Kit w/25' Harness, Waterproof Over 80" Low Pro...	K-18
008540	Plastic Fender, 8"-12" Tire Size, White	M-21
008541	Plastic Fender, 8"-12" Tire Size, White	M-21
008542	Plastic Fender, 12" Tire Size, White	M-21
008543	Plastic Fender, 13" Tire Size, White	M-21
008549	Plastic Fender, 8"-12" Tire Size, White	M-21
008550	Plastic Fender, 8"-12" Tire Size, Black	M-21
008551	Plastic Fender, 8"-12" Tire Size, Black	M-21
008553	Plastic Fender, 13" Tire Size, Black	M-21
008554	Plastic Fender, 14" Tire Size, Black	M-21
008559	Plastic Fender, 8"-12" Tire Size, Black	M-21
008561	Plastic Fender, 8"-12" Tire Size, Silver	M-21
008563	Plastic Fender, 13" Tire Size, Silver	M-21
008564	Plastic Fender, 14" Tire Size, Silver	M-21
008569	Plastic Fender, 8"-12" Tire Size, Silver	M-21
008572	Plastic Fender, 12" Tire Size, White	M-21
008573	Plastic Fender, 13" Tire Size, White	M-21
008574	Plastic Fender, 14" Tire Size, White	M-21
008575	Plastic Fender, 15" Tire Size, White	M-21
008582	Plastic Fender, 12" Tire Size, Black	M-21
008583	Plastic Fender, 13" Tire Size, Black	M-21
008584	Plastic Fender, 14" Tire Size, Black	M-21
008585	Plastic Fender, 15" Tire Size, Black	M-21
008592	Plastic Fender, 12" Tire Size, Silver	M-21
008593	Plastic Fender, 13" Tire Size, Silver	M-21
008594	Plastic Fender, 14" Tire Size, Silver	M-21
008595	Plastic Fender, 15" Tire Size, Silver	M-21
01202-024	Receiver Tube Covers, 2" Sq., Black (24 pack)	B-23
0133313S00	Replacement Part, Handle for F2 FW1600 Winch	J-52
015181	Sidewind Crank Assembly for 180's	J-16, J-29
0152710300	Bracket-Female Swivel-2.5" O.D.	J-8
0152730300	Weld-On Male Swivel Mount, 9/16" Pin for 150's & 170's	J-8
0152790300	Weld-On Male Swivel Mount, 5/8" Pin, 2" O.D. for 170's	J-8
017125	Detachable Steel Wheel Assembly w/Pin for 150 A-Frame's	J-8, J-27
018098	Tongue Jack Support Foot, Removable w/Lock Pin, 6.2" Tall, R...	J-8, J-28
0181730324	Removable Foot Plate, 6.2"	J-28
018507	Kit - Removable Caster Assembly Steel Wheel	J-27
0185640301	Removable Disc Foot w/Pin 2.1" Tall - Plated for 150's & 170's	J-28
01932-003	3/8" Drill Bits (3 pack)	A-11
01933-003	7/16" Drill Bits (3 pack)	A-11
01934-003	1/2" Drill Bits (3 pack)	A-11
01938-003	1/4" Pilot Drill Bits (3 pack)	A-11
0233010300	Kit, Adjustable Tube - Welded 20" w/Pin Hole & 1 Set Bolt	J-44, L-14
0233060301	Replacement Part, Pin Kit for Adjustable Gooseneck Coupler	J-44, L-44
0233100300	Replacement Part, Adjustable Round Gooseneck Coupler Tube, W...	J-44, L-14
0233120300	Square Gooseneck Coupler Outer Tube, Weld On, 20" Length, 4...	J-45, L-15
024200	Replacement Part, High Profile Coupler Repair Kit	J-40, L-10
024202	Replacement Part, Adjustable Height Coupler Mounting Hardwar...	J-42, L-12
0252010201	Kit, Snapper Pin & Chain Assembly	J-28
028242	Coupler, Round Tube Mount, 5000 lbs.	J-40, L-10
028243	Coupler, Square/Rectangular Mount, 7000 lbs.	J-40, L-10

PRODUCT NUMERICAL

PART NO.	DESCRIPTION	PAGE NO.
028244	Coupler, Square/Rectangular Mount, 5000 lbs.	J-40, L-10
028287	Coupler, A-Frame Mount, 7000 lbs.	J-40, L-10
028288	Coupler, A-Frame Mount, 5000 lbs.	J-40, L-10
028352	Hitch Ball, 2" x 1" x 2-1/8", 7000 lbs.	B-4
028375	Hitch Ball, 2" x 3/4" x 2-1/8", 3000 lbs.	B-4
028381	Coupler, Round Tube Mount, 5000 lbs.	J-40, L-10
028382	Coupler, Ball Size 2", Tongue Mount Width 3", Straight Chann...	J-40, L-10
028383	Coupler, Round Straight Mount, 5000 lbs.	J-40, L-10
028384	Coupler, Ball Size 2", A-Frame Coupler, 5,000 lbs.	J-40, L-10
028386	Coupler, Ball Size 2", A-Frame Coupler, 7,000 lbs.	J-40, L-10
028387	Coupler, Ball Size 2", Tongue Mount Width 3", Straight Chann...	J-40, L-10
028390	Adjustable Coupler, 7000 lbs.	J-40, L-10
028400	Hitch Ball, 2-5/16" x 1-1/4" x 2-3/4", 12,500 lbs.	B-4
028442	Coupler, Round Tube Mount, 12,500 lbs.	J-40, L-10
028444	Coupler, Square/Rectangular Mount, 12,500 lbs.	J-40, L-10
028461	Coupler, Round Tube Mount, 12,500 lbs.	J-40, L-10
028462	Coupler, Ball Size 2-5/16", Tongue Mount Width 3", Straight ...	J-40, L-10
028463	Coupler, Ball Size 2-5/16", A-Frame Coupler, 12,500 lbs.	J-40, L-10
028499	Coupler, A-Frame Mount, 12,500 lbs.	J-39, L-9, L-10
028584	Rigid Mount Adjustable Coupler, 7000 lbs.	J-40, L-10
028585	Rigid Mount Adjustable Coupler, 12,500 lbs.	J-40, L-2, L-10
028630	Adjustable Coupler, 12,500 lbs.	J-39, J-40, L-9, L-10
028656	Coupler, Ball Size 2-5/16", A-Frame Coupler, 15,000 lbs.	J-40, L-10
028657	Adjustable Coupler, 15,000 lbs.	J-39, J-40, L-9, L-10
0287600300	20K Adjustable Gooseneck Coupler	J-43, J-44, L-13, L-14
0287620300	20K Adjustable Gooseneck Coupler w/Tube Cap	J-44, L-14
0287650300	20K Round Gooseneck Coupler w/Cable Release-Inner	J-44, L-14
0287690300	20K Fixed Base Gooseneck Coupler	J-44, L-14
0287740300	20K Gooseneck Coupler Kit, Includes Locking Pin Assembly, Lo...	J-44, L-14
0287760300	20K Adjustable Gooseneck - CBL Release	J-44, L-14
0287790300	20K Round Gooseneck Coupler, Dual Set Bolt and Labels	J-46, L-16
0287800300	25K Round Gooseneck Coupler, Dual Set Bolt and Labels	J-46, L-16
0287820300	25K Round Gooseneck Coupler, Includes Locking Pin Assembly, ...	J-46, L-16
0288660300	25K Square Gooseneck, 4" Inner Tube w/Pin & Less Outer Tube	J-44, L-14
028900	30K Adjustable Square Gooseneck	J-43, J-44, L-13, L-14
0289250300	25K Adjustable Round Gooseneck w/Pin & Outer Tube	J-44, L-14
0289340317	25K Round Gooseneck Coupler w/Cable Release	J-44, L-14
0289500300	30K Adjustable Round Gooseneck w/Pin	J-43, J-44, L-13, L-14
0289580300	25K Round King Pin Gooseneck	J-43, J-44, L-13, L-14
0289590300	30K Square King Pin Gooseneck	J-43, J-44, L-13, L-14
0289600300	25K Square Gooseneck w/Pin	J-43, J-44, L-13, L-14
0289640300	25K Round King Pin Gooseneck w/o Outer Tube, 4 Hole	J-44, L-14
0289650300	30K Square King Pin Gooseneck w/o Outer Tube, 4 Hole	J-44, L-14
0289800300	30K Square Gooseneck w/Pin	J-44, L-14
02895B0140	Replacement Part, Adjustable Gooseneck Pinch Bolt Kit	J-44, L-14
05330-010	Hitch Hider Tube Covers, 2" Sq. Receivers w/Built-In 4-Flat ...	B-23
06237	1/2" Hitch Pin for 1-1/4" Class I and Class II, Zinc	B-18
07010-024	Receiver Tube Cover, 2" Sq., Black Rubber (24 pack)	B-23
0917501S00	Wheel Replacement - Plain w/UPC	J-27
0933301S00	Replacement Part, Service Kit, Handle-Marine JK 800 lbs.	J-37
0933302S00	Replacement Part, Service Kit, Bevel	J-37
0933305S00	Replacement Part, Service Kit, Handle-Sidewind Jacks	J-37
0933306S00	Replacement Part, Service Kit, Bevel Gear-1200 lbs. Jacks	J-34, J-37
0933307S00	Replacement Part, Service Kit, Plunger Pin 1/2" S-Mount	J-37
0933325S00	Replacement Part, Service Kit, Bolt-On Hardware	J-37
1000750	Water Wick, 750 Gram	M-23
100235	Grease Cap, 2.333" Zinc Plated	M-20
101469	4-Flat Car End Connector 72" Long, 72" Ground (Includes Wire...	C-15
10184	1-1/4" Stationary Assembly for ROLA® Adventure System, 150 L...	I-9
10186	2" Tilt-Up Assembly for ROLA® Adventure System, 250 lbs. Cap...	I-9
10188	ROLA®, Adventure System includes Tray (with taillights) and ...	I-9
1024	Accelerated Battery Charging Device (ABCD)	M-6
1026	Shur-Set III® Breakaway System w/5 Amp/Hr Battery (Includes ...	M-2, M-5
102639	Replacement Part, Lens Red, Clearance/Side Marker	K-18
102641	Replacement Part, Lens Red, Taillight Over 80"	K-18
1028	Shur-Set III® Breakaway System w/5 Amp/Hr Battery(with ABCD)...	M-5
1040100	Solo™ Cargo Carrier w/3" Side Rails, 32" x 48" Platform, 2" ...	I-10
1040200	Cargo Carrier Accessory, Loading Ramp for #1040100	I-10
1041100	Rainproof Expandable Cargo Carrier Bag	5, I-2, I-14
1041500	Cargo Carrier for 1-1/4" Sq. Receivers, 20" x 48" Platform	I-10

PART NO.	DESCRIPTION	PAGE NO.
10421	2" Swing-Away Assembly for ROLA® Adventure System, 250 lbs. ...	I-9
104393	4-Flat Dust Cover	C-18
104429	Plastic Wire Clip w/ Adhesive Back	C-35
105728	Plug Holder for AG 7-Way Round Pin Trailer Connector, Traile...	L-6
106289	Replacement Part, Clearance Light Base, Chrome 2" Snap-Lock,...	K-22, K-24, K-29
106293	Replacement Part, Clearance Light Base, Chrome 2" Snap-Lock,...	K-22, K-24, K-29
106294	Replacement Part, Module, Utility, Snap-lock, Clear	K-24, K-29
106310	Replacement Part, Single Plug for Snap-lock Base	K-40
106334	Replacement Part, Pigtail	K-29
106410	8-Function, Left/Roadside, Trailer Ground Connection w/ Mold...	K-18
106411	7-Function, Right/Curbside, Trailer Ground Connection w/Mold...	K-18
106873	Replacement Part, 6" Oval Mounting Bracket	K-9, K-17, K-22, K-35
108060	Ag Light Enhanced Lighting Module w/ Wire Leads	L-7
108119	Mounting Bracket, 6" Oval Taillight	K-9, K-17, K-22, K-35
108297	Replacement Part, Base only, Black, Open Back "15 Series"	K-22, K-24, K-29
108318	Ag Light Enhanced Lighting Module w/ Molded Plugs	L-7
108319f	Ag Light Enhanced Lighting Module w/ Weatherproof Plugs	L-7
108663	Replacement Part, Plug, 2-Way, 18" w/#10 Ring	K-22, K-23, K-24, K-26, K-29, K-30, K-40
108820	4-Flat Trailer End Connector, 20" Wishbone Harness, 30" Ground	C-15
108825	4-Flat Trailer End Connector, 25" Wishbone Harness, 30" Ground	C-15, K-7, K-8, K-18
108830	4-Flat Trailer End Connector, 30" Wishbone Harness, 30" Ground	C-15
108835	4-Flat Trailer End Connector, 35" Wishbone Harness, 30" Ground	C-15
108840	4-Flat Trailer End Connector, 40" Wishbone Harness, 30" Ground	C-15
108843	Replacement Part, Lens Amber, Clearance Light	K-35
108844	Replacement Part, Lens Red, Clearance Light	K-35
108891	Replacement Part, Bulb #193	K-15, K-18, K-19, K-20, K-31, K-33, K-35, K-44
109992	Ag Light Enhanced Lighting Module w/ Brake Light Signal Func...	L-7
11003	Receiver Extension, 2" to 2" Extension, 14" Length, 400/4,00...	B-14
11004	Receiver Extension, 2" to 2" Extension, 18" Length, 400/4,00...	B-14
11006	Receiver Extension w/Step, 2" to 2" Extension, 18" Length, 4...	B-14
11029	Receiver Fabrication Part, 18" Combo Bar 2-1/2" Sq. ID, Unpa...	A-10
11081	Receiver Fabrication Part, 8" Combo Bar 2" Sq. ID, Unpainted	A-10
111428	Replacement Part, Lynch Pin 3/16" for Signature Series Fifth...	O-10, O-11, O-12
11200 0101	Coupler, Class I, 1-7/8" Ball, 2" Channel, 2000 lbs. - Zinc	J-48
11200 0317	Coupler, Class I, 1-7/8" Ball, 2" Channel, 2000 lbs. - Primed	J-48
1124	Hole Saw Arbor w/Pilot Drill Bit for #1123/#58381	A-11
11250 0101	Coupler, Class I, 1-7/8" Ball, 2-1/2" Channel, 2000 lbs. - Zinc	J-48
11250 0317	Coupler, Class I, 1-7/8" Ball, 2-1/2" Channel, 2000 lbs. - P...	J-48
11300 0101	Coupler, Class I, 1-7/8" Ball, 3" Channel, 2000 lbs. - Zinc	J-48
11300 0317	Coupler, Class I, 1-7/8" Ball, 3" Channel, 2000 lbs. - Primed	J-48
1151601	Ratchet Tie Down - 1-1/4" x 10", 3,300 lbs. - Break Strength	I-31
1151701	Ratchet Tie Down - 1-1/2" x 15", 5,500 lbs. - Break Strength	I-31
1151801	Retractable Ratchet Tie Down - 1" x 6", 500 lbs. (2 pack)	I-31
1152101	Ratchet w/Padded Handle Tie Down - 1" x 6", 1,800 lbs. - Bre...	I-31
1152500	HD Ratchet Tie Down - 2" x 25", 10,000 lbs. - Break Strength	I-31
1153500	Retractable Ratchet Tie Down - 1" x 6", 400 lbs., Camo (2 pack)	I-31
1154000	Retractable Ratchet Tie Down - 2" x 10", 1100 lbs. (Single)	I-31
1160400	Ratchet Tie Down w/Reflective Webbing - 1" x 12" (4 pack)	I-31
117300	Replacement Part, Elite Fifth Wheel Head Kit	F-5, G-8, O-10, O-11, O-12, O-16
11755	Electrical Contact Grease, 2 Oz. Tube	C-35
118001	4-Flat Car End Connector 48" Long (Includes 4 Wire Taps)	C-16
118001-024	4-Flat Car End Connector 48" Long (24 pack)	C-16
118001-200	4-Flat Car End Connector 48" Long (200 pack)	C-16
118002	4-Flat Car End Connector 60" Long (Includes 4 Wire Taps)	C-16
118002-024	4-Flat Car End Connector 60" Long (24 pack)	C-16
118002-200	4-Flat Car End Connector 60" Long (200 pack)	C-16
118004	4-Flat Trailer End Connector, 12" Long	C-16
118004-012	4-Flat Trailer End Connector, 12" Long (12 pack)	C-16
118009	4-Flat Trailer End Connector, 21" Long	C-16
118016	5-Flat 72" Car End Wiring Harness	C-19
118016-025	5-Flat 72" Car End Wiring Harness (25 pack)	C-19
118017	5-Flat 48" Trailer End Wiring Harness	C-19
118019	7-Way to Cigarette Lighter Plug Adapter	C-29

PRODUCT NUMERICAL

PART NO.	DESCRIPTION	PAGE NO.
118020	7-Way Flat Pin Connector, Car End, Plastic	C-2, C-21
118020-006	7-Way Flat Pin Connector, Car End, Plastic (6 pack)	C-21
118020-050	7-Way Flat Pin Connector, Car End, Plastic (50 pack)	C-21
118021	7-Way Flat Pin Connector, Trailer End, Plastic	C-21
118021-006	7-Way Flat Pin Connector, Trailer End, Plastic (6 pack)	C-21
118021-050	7-Way Flat Pin Connector, Trailer End, Plastic (50 pack)	C-21
118022	2-Flat Electrical Connector Loop, 12" Long	C-18
118030	7-Way Flat Pin Connector, Car End, Metal	C-2, C-21
118031	7-Way Flat Pin Connector, Trailer End, Metal	C-21
118032	4-Flat to 4-Flat Universal Adapter	C-29
118033	4-Flat Trailer End Connector, 48" Long	C-16
118033-012	4-Flat Trailer End Connector, 48" Long (12 pack)	C-16
118036	6-Way Round Pin Connector, Car End, Metal	C-20
118036-006	6-Way Round Pin Connector, Car End, Metal (6 pack)	C-20
118036-050	6-Way Round Pin Connector, Car End, Metal (50 pack)	C-20
118037	6-Way Round Pin Connector, Trailer End, Metal	C-20
118037-006	6-Way Round Pin Connector, Trailer End, Metal (6 pack)	C-20
118037-050	6-Way Round Pin Connector, Trailer End, Metal (50 pack)	C-20
118043	4-Flat Car End Connector 30" Long, "The Knockout" Connector	C-17
118044	4-Flat Plug Loop, 48" Long (Includes 4 Wire Taps)	C-16
118044-010	4-Flat Plug Loop, 48" Long (10 pack)	C-16
118044-175	4-Flat Plug Loop, 48" Long (175 pack)	C-16
118045	4-Flat Plug Loop, 60" Long (Includes 4 Wire Taps)	C-16
118045-010	4-Flat Plug Loop, 60" Long (10 pack)	C-16
118045-175	4-Flat Plug Loop, 60" Long (175 pack)	C-16
118077	4-Way Round Connector, Car and Trailer End, Metal	C-17
118101	4-Way Round Connector, Car End, Metal	C-17
118102	4-Way Round Connector, Trailer End, Metal	C-17
118104	4-Flat Trailer End Connector to 6 Pole Square Adapter for Ja...	C-20
118132	Mounting Bracket Combo for 4-Way & 6-Way Round Connectors	C-32
118136	Universal Mounting Bracket and Clamp (Long)	C-33
118137	Mounting Bracket for 4, 5 and 6-Way Connectors, Includes Scr...	C-33
118137-010	Mounting Bracket for 4, 5 and 6-Way Connectors (10 pack)	C-33
118138	Mounting Bracket for 7-Way Flat Pin Connectors, Includes Scr...	C-33
118138-010	Mounting Bracket for 7-Way Flat Pin Connectors (10 pack)	C-33
118140	Universal Mounting Bracket and Clamp (Short)	C-33
118144	4-Flat Mounting Bracket	C-33
118144-010	4-Flat Mounting Bracket (10 pack)	C-33
118145	Plug Storage Box for 4-Flat Connector	C-34
118147-0251	Cover w/Led Tester, 4-Flat Connector	C-18
118149	4-Flat Universal Mounting Bracket	C-33
118149-010	4-Flat Universal Mounting Bracket (10 pack)	C-33
118150	Wiring Kit for Installing #118146, #118176, #118187, #118190...	C-12
118151	Wiring Kit for Installing #118146, #118176, #118187, #118190...	C-12
118152	Trailer Plug Holder for 6 & 7-Way Trailer Plugs	C-34
118156	6 & 7-Way Connector Mounting Box, 2-1/2" Crosstubes	C-34
118156-010	6 & 7-Way Connector Mounting Box, 2-1/2" Crosstubes (10 pack)	C-34
118157	6 & 7-Way Connector Mounting Box, 3" Crosstubes	C-34
118157-010	6 & 7-Way Connector Mounting Box, 3" Crosstubes (10 pack)	C-34
118158	2 to 3 Taillight Converter for Connecting Tow Vehicles w/2 W...	C-14
118159	6 & 7-Way Connector Mounting Box, Universal for Round & Squa...	C-34
118159-010	6 & 7-Way Connector Mounting Box, Universal for Round & Squa...	C-34
118172-024	4-Flat Car End Connector 72" Long (24 pack)	C-16
118172-150	4-Flat Car End Connector 72" Long (150 pack)	C-16
118185	4-Flat Plug Loop, 18" Long (Includes 4 Wire Taps)	C-16
118185-025	4-Flat Plug Loop, 18" Long (25 pack)	C-16
118185-200	4-Flat Plug Loop, 18" Long (200 pack)	C-16
118192	4-Flat Trailer End Connector, Dual Taillight Wires, 25" Long	C-16
118215	5-Flat Plug Loop 60" Long, Car & Trailer End Wiring Harness	C-19
118601	4-Flat to 4-Flat "The Knockout" Adapter	C-29
118603	4-Flat Car End Connector 60" Long, "The Knockout" Connector	C-17
118607	Pre-Wired Brake Mate™ Kit Adapter, 7-Way Flat Pin Connector ...	C-31, D-11
118615-0201	4-Flat Plug Loop, 72" Long (20 pack)	C-16
118636	4-Flat Plug Loop, 24" Long (Includes 4 Wire Taps)	C-16
118664	7-Way U.S. Car End to 7-Way Trailer End Extension Cable 7'	C-24
118665	Battery Isolation Solenoid, 3 Pole, 12 Volt (Chassis Ground)	C-36
118666	6-Way Car End to 6-Way Trailer End Extension Cable 7'	C-24
118700	6-Way Round Pin to 4-Flat Adapter	C-29
118700-050	6-Way Round Pin to 4-Flat Adapter (50 pack)	C-29
118702	7-Way Flat Pin to 4-Flat Adapter	C-29
118702-050	7-Way Flat Pin to 4-Flat Adapter (50 pack)	C-29
118703	7-Way Flat Pin to 5-Flat Adapter	C-29
118704	7-Way Flat Pin to 6-Way Round Adapter w/Electric Brakes to O...	C-29
118704-050	7-Way Flat Pin to 6-Way Round Adapter w/Electric Brakes to O...	C-29
118708	7-Way Flat Pin to 6-Way Round Adapter w/Electric Brakes to C...	C-29
118708-050	7-Way Flat Pin to 6-Way Round Adapter w/Electric Brakes to C...	C-29
118709	7-Way Round Pin to 4-Flat Adapter	C-29
118710	7-Way European Style Round Pin to 4-Flat Adapter	C-29

PART NO.	DESCRIPTION	PAGE NO.
118799	Pre-Wired Adapter, 7-Way Flat Pin Connector w/Brake Control ...	C-31
118821	Taillight Isolating System w/4-Flat	C-14
119130	Taillight Converter w/12" Leads and 60" 4-Flat Car End Conne...	C-13
119130-012	Taillight Converter w/12" Leads and 60" 4-Flat Car End Conne...	C-13
119130-050	Taillight Converter w/12" Leads and 60" 4-Flat Car End Conne...	C-13
119147	ModuLite® HD Protector Trailer Light Power Module	C-10
119147-012	ModuLite® HD Protector Trailer Light Power Module (12 pack)	C-10
119147-050	ModuLite® HD Protector Trailer Light Power Module (50 pack)	C-10
119148	ModuLite® HD Protector Trailer Light Power Module & Installa...	C-10
119177	ModuLite® HD Protector w/Integrated Circuit & Overload Prote...	C-11
119178	Taillight Converter with Integrated Circuit Protection	C-13
119178-012	Taillight Converter with Integrated Circuit Protection (12 p...	C-13
119178-050	Taillight Converter with Integrated Circuit Protection (50 p...	C-13
119179	ModuLite® Protector w/Integrated Circuit Protection	C-10
119179-012	ModuLite® Protector w/Integrated Circuit Protection (12 pack)	C-10
119179-050	ModuLite® Protector w/Integrated Circuit Protection (50 pack)	C-10
119180	ModuLite® Protector w/Integrated Circuit Protection & Instal...	C-10
119190	ModuLite® HD Plus Protector w/Integrated Circuit & Overload ...	C-11
119190-012	ModuLite® HD Plus Protector w/Integrated Circuit & Overload ...	C-11
119190-050	ModuLite® HD Plus Protector w/Integrated Circuit & Overload ...	C-11
119191	ModuLite® HD Plus Protector w/Integrated Circuit & Overload ...	C-11
119192	ModuLite® Ultra Protector w/Integrated Circuit & Overload Pr...	C-12
119250	ZCI™ Zero Contact Interface Universal ModuLite®	4, C-2, C-9
119251	ZCI™ Zero Contact Interface Universal ModuLite® & Installati...	C-9
1202	Receiver Tube Cover, 2" Sq, Black	B-23
1227000	Ratchet Tie Down - 1" x 10', 900 lbs. - Break Strength	I-31
1289000300	BX1™ 25K Round Gooseneck Coupler, Includes Locking Pin Assem...	J-45, L-15
1289020300	BX1™ 25K Round Gooseneck Coupler w/o Outer Tube, Includes Lo...	J-45, L-15
1289030300	BX1™ 20K Round Gooseneck Coupler, Includes Locking Pin Assem...	J-45, L-15
1289040300	BX1™ 30K Round Gooseneck Coupler, Short Configuration , Incl...	J-45, L-15
1289050300	BX1™ 30K Round Gooseneck Coupler w/o Outer Tube, Short Confi...	J-45, L-15
1289070300	BX1™ 20K Round Gooseneck Coupler, Short Configuration , Incl...	J-45, L-15
1289080300	BX1™ 25K Round Gooseneck Coupler, Short Configuration , Incl...	J-45, L-15
1289130300	BX1™ 25K Square Gooseneck Coupler, Includes Hex Head Bolt & ...	J-45, L-15
1289140300	BX1™ 30K Square Gooseneck Coupler, Includes Hex Head Bolt & ...	J-45, L-15
1289170300	BX1™ 20K Round Gooseneck Coupler w/o Outer Tube, Includes Lo...	J-45, L-15
1289200300	BX1™ 40K Square Gooseneck Coupler for 3" Ball, Includes Lock...	J-45, L-15
1289210300	BX1™ 25K Square Gooseneck Coupler w/o Outer Tube, Short Conf...	J-45, L-15
1291020340	Adjustable Lunette Ring, 3" Dia., 14,000 lbs. Capacity (Adju...	B-2, B-16
1291020383	Adjustable Lunette Ring, 3" Dia., 14,000 lbs. Capacity (Adju...	B-2, B-16
1390300	Bike Carrier, 3 Bike, Dual Arm, Trunk Mount	I-5
1390600	Ratcheting Cargo Bar 40" to 70"	I-2, I-12
1390800	Universal Pet Barrier	I-36
1391300	Roof Top Cargo Carrier (44" x 35" x 4-1/4"), 3 - Piece w/Cus...	I-11
1391800	Rainproof, Expandable Car Top Cargo Bag	I-14
1392900G	Bike Carrier, 2 Bike, Trunk Mount Rack	I-5
1393100G	BIKE CARRIER 4 PLC	I-4
1393700	Stretch Net Cargo Net for Cargo Carriers & Roof Rack	I-12
1394900	KAYAK CARRIER J-RAC	I-2, I-12
1400300303	Pro Series™ Bolt-On Jack, Topwind, 2,000 lbs. w/Footplate	J-10
1400400303	Pro Series™ Weld-On Jack, Topwind, 10" Travel, 2,000 lbs. w...	J-10
1400600303	Pro Series™ A-Frame Jack, 5,000 lbs.	J-9
1400700340	Pro Series™ Footplate & Pin	J-9
1400750340	6" Caster, Poly	J-9
1400800383	Pro Series™ Square Tube, 8,000 lbs., Topwind, 15" Travel, Ad...	J-20
1400830383	Pro Series™ Weld-On Square Tube, 8,000 lbs., Topwind, Tubula...	J-20
1400850383	Pro Series™ Square Tube, 8,000 lbs., Sidewind, 15" Travel, A...	J-20
1400860383	Pro Series™ Weld-On Square Tube, 8,000 lbs., Sidewind, Tubul...	J-20
1400920383	KIT-JACK HNDL W/MNT HDWR	J-20
140094	Pro Series™ Weld-On Jack Square Tube, 12,000 lbs., Sidewind...	J-20
1400950376	Pro Series™ Weld-On Jack Square Tube, 12,000 lbs., Sidewind...	J-20
1400960376	Pro Series™ Weld-On Jack Square Tube, 12,000 lbs., Sidewind...	J-20
1400980376	Pro Series™ Weld-On Jack Square Tube, 12,000 lbs., Sidewind...	J-20
1400990376	Pro Series™ Weld-On Jack Square Tube, 12,000 lbs., Sidewind...	J-20
1401000303	Pro Series™ A-Frame Jack, 2,000 lbs.	J-9
1401010376	Pro Series™ Weld-On Jack Square Tube, 12,000 lbs., Sidewind...	J-20
1401020303	Pro Series™ Weld-On Jack, Sidewind, 2,000 lbs. w/Footplate	J-10
1401030303	Pro Series™ Weld-On Jack, Sidewind, 2,000 lbs. w/Footplate	J-10
1401040303	Pro Series™ Weld-On Jack, Topwind, 2,000 lbs. w/Footplate	J-10
1401060303	Pro Series™ Weld-On Jack, Sidewind, 2,000 lbs. w/Footplate	J-10
1401080303	Pro Series™ Weld-On Jack, Sidewind, 2,000 lbs. w/Footplate	J-10
1401140303	Pro Series™ Weld-On Jack, Topwind, 2,000 lbs. w/Footplate	J-10
1401200303	Pro Series™ Weld-On Jack, Topwind, 2,000 lbs. w/Footplate	J-10
1401240303	Pro Series™ Weld-On Jack, Sidewind, 5,000 lbs.	J-10
1401440303	Pro Series™ Weld-On Jack, Sidewind, 5,000 lbs. w/Footplate	J-10
1401460303	Pro Series™ Weld-On Jack, Topwind, 5,000 lbs.	J-10
1401480303	Pro Series™ Weld-On Jack, Topwind, 5,000 lbs. w/Footplate	J-10
1401500383	Pro Series™ Square Tube, 5,000 lbs., Topwind, 15" Travel, Ad...	J-20

PRODUCT NUMERICAL

PART NO.	DESCRIPTION	PAGE NO.
1401520383	Pro Series™ Square Tube, 5,000 lbs., Topwind, Weld-On Tubula...	J-20
1401600383	Pro Series™ Square Tube, 5,000 lbs., Sidewind, 15" Travel, A...	J-20
1401610383	Pro Series™ Square Tube, 5,000 lbs., Sidewind, Weld-On Tubul...	J-20
1410050149	400 lbs., Trailer Stand, Swivel, 6" Poly Wheel	J-36
1411300301	Jack, 1,500 lbs., Bolt-On, Independent Caster, Torsion Axle ...	J-36
141132	XLT Jack, 1,500 lbs., Swing Away, Weld-On, 12" Travel, Paten...	J-34
141133	XLT Jack, 1,500 lbs., Swing Away, Bolt-On (Mounting Hardware...	J-2, J-34
141135	XLT Jack, 1,500 lbs., Swing Away, Weld-On, 10" Travel, Paten...	J-34
1413020134	F2™ Jack, 1,600 lbs., Twin Track	J-31
1413040134	F2™ Jack, 1,600 lbs., Wide Track	J-31
1413050334	F2™ Jack, 1,600 lbs., Wide Track, Includes Handle Holdup, We...	J-31, P-11
1413130334	F2™ Jack, 1,600 lbs., Twin Track, 5" Tongue Bolt-On Hardware...	J-31
1413140334	F2™ Jack, 1,600 lbs., Wide Track, 5" Tongue Bolt-On Hardware...	J-31
1413200334	F2™ Jack, 2,000 lbs., Swivel w/Foot Plate, Weld-On	J-32, P-11
1413230134	F2™ Jack, 2,000 lbs., Swivel w/Foot Plate, Bolt-On	J-32
1413250334	F2™ Jack, RV A-Frame	J-33
142001	Winch, 900 lbs., Single-Speed	J-53
142002	Winch, 900 lbs., Single-Speed	J-53
142003	Winch, 900 lbs., Single-Speed w/15" Strap	J-53
142006	Winch, 900 lbs., Single-Speed for Personal Watercraft, w/12" ...	J-53
142007	Winch, 900 lbs., 2-WAY RATCHET W/STRAP	J-53
142100	Winch, 1100 lbs., Single-Speed	J-53
142101	Winch, 1100 lbs., Single-Speed	J-53
142102	Winch, 1100 lbs., Single-Speed w/20" Strap	J-53
142103	Winch, 1300 lbs., Single-Speed	J-53
142104	Winch, 1300 lbs., Single-Speed	J-53
142200	Winch, 1500 lbs., Single-Speed	J-53
142201	Winch, 1500 lbs., Single-Speed	J-53
142203	Winch, 1500 lbs., Single-Speed w/20" Strap	J-53
142204	Winch, 1500 lbs., Single-Speed w/20" Strap	J-53
142208	Winch, 1500 lbs., Single-Speed w/20" Strap & Cover	J-53
142300	Winch, 1800 lbs., Single-Speed	J-53
142301	Winch, 1800 lbs., Single-Speed	J-53
142305	Winch, 1800 lbs., Single-Speed w/20" Strap	J-53
142306	Winch, 1800 lbs., Single-Speed w/20" Strap	J-53
142311	Winch, 1400 lbs., Single-Speed w/20" Strap, Black Cover	J-2, J-53
142314	Winch, 1800 lbs., Single-Speed w/20" Strap, Black Cover	J-50, J-53
142315	Winch, 1800 lbs., XLT-Black	J-53
142320	Winch, 1400 lbs., Single-Speed w/20" Strap, Black Cover	J-53
142400	Two Speed Winch	J-55
142401	Two Speed Winch	J-55
142403	Two Speed Winch	J-55
142410	Two Speed Winch	J-55
142411	Two Speed Winch	J-55
142412	Two Speed Winch	J-55
142414	Two Speed Winch	J-55
142415	Two Speed Winch	J-55
142416	Two Speed Winch	J-55
142418	Winch, 2600 lbs., 2-Speed w/20" Strap, 10" Handle, Black Cover	J-55
142419	Winch, 2600 lbs., 2-Speed w/20" Strap, 6-1/4" Handle, Black ...	J-55
142420	Two Speed Winch	J-55
142421	Two Speed Winch	J-55
142423	Winch, 3200 lbs., 2-Speed-Brake-w/HD Strap	J-55
142425	Two Speed Winch	J-55
142430	Two Speed Winch	J-50, J-55
143001	Brake Winches	J-57
143002	Brake Winches	J-57
143005	Brake Winches	J-57
143006	Brake Winches	J-57
143100	Brake Winches	J-57
143101	Brake Winches	J-57
143104	Brake Winches	J-57
143105	Brake Winches	J-57
143200	Brake Winches	J-50, J-57
143201	Brake Winches	J-57
14-715810	7-Way Junction Box	C-34
148700	Multi-Jack w/Foot Plate, 7,000 lbs. Capacity, 35" Travel	J-38, L-2, L-8
150000	Jack, Topwind, 10" Travel, No Mount or Base, 2,000 lbs. Lift...	J-7
150152	Jack, Sidewind, 15" Travel, No Mount, 2000 lbs. Lift Capacity	J-7
150441	TWS 150DTSFX w/P&C PLTD	J-5
151101	Weld-On Jack, Sidewind, 10" Travel, Weld-On "L" Bend Swivel ...	J-7
1511010117	Weld-On Jack, Sidewind, 10" Travel, Weld-On "L" Bend Swivel ...	J-7
151159	Weld-On Jack, Sidewind, 15" Travel, Weld-On "L" Bend Swivel ...	J-7
151401	Weld-On Jack, Topwind, 10" Travel, Weld-On "L" Bend Swivel B...	J-7
1514010117	Weld-On Jack, Topwind, 10" Travel, Weld-On "L" Bend Swivel B...	J-7
151421	Bulldog Tongue Jack, Swivel Jack, Topwind, 15" Travel, Weld...	J-7
1514210117	Weld-On Jack, Topwind, 15" Travel, Weld-On "L" Bend Swivel B...	J-7
151443	Bolt-On Jack, Topwind, 10" Travel, Bolt-On Swivel Bracket, 2...	J-7

PART NO.	DESCRIPTION	PAGE NO.
151460	TWS 151 DS Jack	J-7
1542301	Replacement Part, Repair Kit (GN24). Includes Torsion Spring...	J-44, L-14
1550100117	A-Frame Jack, Sidewind, 13" Travel, 7" Bracket to Ground Ret...	J-6
1550100317	A-Frame Jack, Sidewind, 13" Travel, 7" Bracket to Ground Ret...	J-6
1550101344	A-Frame Jack, Sidewind, 13" Travel, 7" Bracket to Ground Ret...	J-6
155022	A-Frame Jack, Topwind, 15" Travel, 8.4" Bracket to Ground Re...	J-6
1550220117	A-Frame Jack, Topwind, 15" Travel, 8.4" Bracket to Ground Re...	J-6
155028	A-Frame Jack, Topwind, 8.4" Bracket to Ground Retracted, 2.0...	J-6
155032	A-Frame Jack, Topwind, 15" Travel, 10.15" Bracket to Ground ...	J-6
1550320117	A-Frame Jack, Topwind, 15" Travel, 10.15" Bracket to Ground ...	J-6
155033	A-Frame Jack, Topwind, 15" Travel, Weld-On/Bolt-On, 2,000 lb...	J-6
155100	A-Frame Jack, Topwind, 2,000 lbs. Lift Cap., 7.5" Bracket to...	J-6
155157	A-Frame Jack, Sidewind, 13" Travel, 8.6" Bracket to Ground R...	J-6
1551570117	A-Frame Jack, Sidewind, 13" Travel, 8.6" Bracket to Ground R...	J-6
158109	Swivel Jack, Sidewind, 10" Travel, Weld-On Tubular Mount, 2...	J-5
1581090117	Swivel Jack, Sidewind, 10" Travel, Weld-On Tubular Mount, 2...	J-5
1581090301	Swivel Jack, Sidewind, 10" Travel, Weld-On Tubular Mount, 2...	J-6
158151	Swivel Jack, Sidewind, 15" Travel, Weld-On Tubular Mount, 2...	J-6
1581510117	Swivel Jack, Sidewind, 15" Travel, Weld-On Tubular Mount, 2...	J-6
158451	Swivel Jack, Topwind, 10" Travel, Weld-On Tubular Mount, 2.0...	J-5
1584510117	Swivel Jack, Topwind, 10" Travel, Weld-On Tubular Mount, 2.0...	J-5
158452	Swivel Jack, Topwind, 15" Travel, Weld-On Tubular Mount, 2.0...	J-5
1584520117	Swivel Jack, Topwind, 15" Travel, Weld-On Tubular Mount, 2.0...	J-5
158488	TWL 150 DTSF w/P&C-w/Mount	J-5
1596S01	Service Kit, Ratchet Repair for F2 1,600 lbs. Winch	J-52
161300	Weld-On L-Bend Bracket, Steel Wheel	J-26
162300	Bolt-On L-Bend Bracket, Steel Wheel	J-25, J-26
165111	A-Frame Weld-On/Bolt-On Bracket, Disc Foot	J-26
165211	A-Frame Weld-On/Bolt-On Bracket, Polyolefin Wheel	J-26
165311	165 W, 16" Travel, Includes #018155 Gearbox and #018006 Rack...	J-25, J-26
165411	Heavy Duty Jack, A-Frame Weld-On/Bolt-On Bracket, Heavy-Dut...	J-26
165412	Heavy Duty Jack, A-Frame Weld-On/Bolt-On Bracket, Heavy-Dut...	J-25, J-26
169201	Bolt-On Mount, 3"x5" Tongue, Mounting Kit, Polyolefin Wheel...	J-26
1700100117	A-Frame Jack, Sidewind, 15" Travel, Weld-On/Bolt-On, 5,000 L...	J-7
1700100301	A-Frame Jack, Sidewind, 15" Travel, Weld-On/Bolt-On, 5,000 L...	J-7
1700100317	A-Frame Jack, Sidewind, 15" Travel, Weld-On/Bolt-On, 5,000 L...	J-7
1701480317	TWL 170 X, 5,000 lbs. Lift Cap., 15" Travel, No Mount	J-7
170205	SWL 170, 5,000 lbs. Lift Cap., 15" Travel, Less Base, No Mount	J-7
171401	Weld-On Jack, Topwind, 10" Travel, Weld-On "L" Bend Swivel B...	J-7
171412	Weld-On Jack, Topwind, 15" Travel, Weld-On "L" Bend Swivel B...	J-7
1750290301	TWL 175 X A-Frame, 5,000 lbs. Lift Capacity	J-7
1750290317	TWL 175 X A-Frame, 5,000 lbs. Lift Capacity	J-7
178101	Swivel Jack, Topwind, 10" Travel, Weld-On Tubular Mount, 5.0...	J-6
1781010117	Swivel Jack, Topwind, 10" Travel, Weld-On Tubular Mount, 5.0...	J-6
178151	Swivel Jack, Topwind, 15" Travel, Weld-On Tubular Mount, 5.0...	J-6
1781510117	Swivel Jack, Topwind, 15" Travel, Weld-On Tubular Mount, 5.0...	J-6
178201	Swivel Jack, Sidewind, 10" Travel, Weld-On Tubular Mount, 5...	J-6
1782010117	Swivel Jack, Sidewind, 10" Travel, Weld-On Tubular Mount, 5...	J-6
178203	Swivel Jack, Sidewind, 15" Travel, Weld-On Tubular Mount, 5...	J-6
18004001	4-Flat Trailer End Connector, 12" Long	C-15
180304	TWS 180 DL-BQ, 10,000 lbs. Support Cap., 10" Travel, 10.12" ...	J-14
180354	TWL 180 DL-BQ, 10,000 lbs. Support Cap., 15" Travel, 13.50" ...	J-14
180405	SWS 180 DL-BQ Jack Assembly	J-14
18044001	4-Flat Loop, 48" Long (Includes Wire Taps)	C-15
18045001	4-Flat Loop, 60" Long (Includes Wire Taps)	C-15
180455	SWL 180 DL-BQ, 10,000 lbs. Support Cap., 15" Travel, 13.50" ...	J-14
180587	SWL 180 FL-BTSXQ w/P&C Jack	J-14
18148	Tow Light Kit - Includes 2 Magnetic Base Lights and Leads	K-16
18185001	4-Flat Loop, 18" Long (Includes Wire Taps)	C-15
182300	TWQ 180 DL-B Less Crank (800075)	J-15
182304	TWQ 180 DL-BC, w/Crank (800075) Attached	J-15
1823050383	Heavy Duty Jack, Single Speed, Direct Weld Mount (Crank Sold...	J-23
1823060383	Heavy Duty Jack, Single Speed, Bolt-On Mount (Crank Sold Sep...	J-23
182400	SWQ 180 DL-B Less Crank	J-15
182404	12,000 lbs. - Sidewind Heavy Duty Square Jack - 12-1/2" Travel	J-15
182411	SWQ 180 DL-B Less Crank - Pin to the Curb	J-15
182415	SWQ 180 DL BX Less Crank - Pin to the Front	J-15
1824180100	Electric Powered Kit - 12K 2-Speed	J-19
1824200100	Electric Powered Kit - 12K	J-19
182500	SWQ 180 FL-B Less Crank	J-15
182524	SWQ 180 TS-FL-BX w/Crank (015181)	J-16
182700	Twin Cam HD Jack, Sidewind, 25,000 lbs. Static, 12,500 lbs. ...	J-17
182701	Twin Cam HD Jack, Sidewind, 25,000 lbs. Static, 12,500 lbs....	J-17
182800	SWQ 180 DL-B-SR Less Crank	J-16
182804	SWQ 180 DL-BC-SR w/Crank (015181) Attached	J-16
182805	SWQ 180 DL-BX w/SR, Less Crank - Pin To The Curb - Companion...	J-16
182815	SWQ 180 DL BX SR Less Crank - Pin To The Front	J-16
183401	SWQ 183 DL-BX Pin To The Side, 2-Speed	J-18

PRODUCT NUMERICAL

PART NO.	DESCRIPTION	PAGE NO.
183416	SWQ 183 DL-BX Pin To The Front, 2-Speed	J-18
183749	Twin Cam HD Jack, Sidewind 2-Speed, 25,000 lbs. Static, 25.0...	J-17
183750	Twin Cam HD Jack, Sidewind 2-Speed, 25,000 lbs. Static, 25.0...	J-17
183816	SWQ 183 DL-BX Spring Return - Pin To The Front, 2-Speed	J-18
183900	Heavy Duty Jack, 2-Speed, Painted Outer Tube, Inner Tube, an...	J-18
183901	SWQ 180 DL-BX T Pin To Front, 2-Speed	J-18
183902	SWQ 180 DL-B T Spring Return - Pin To Side, 2-Speed	J-18
183903	SWQ 180 DL-BX T Spring Return - Pin To Front, 2-Speed	J-18
1839050383	Heavy Duty Jack, Single Speed, Direct Weld Mount (Crank Sold...	J-23
1839060383	Heavy Duty Jack, Single Speed, Bolt-On Mount (Crank Sold Sep...	J-23
185400	Velocity Series™ High Speed Jack, 12,000 lbs.	5, J-2, J-21
185402	Velocity Series™ High Speed Jack, 12,000 lbs., Less Remote	J-21
190704	TWL 190 DL-BQ, 8,000 lbs. Support Cap., 15" Travel, Drop Leg...	J-13
1907040176	TWL 190 DL-BQ, 8,000 lbs. Support Cap., 15" Travel	J-13
190705	TWS 190 FL-BTSMQ w/P&C, 8,000 lbs. Support Cap., 10" Travel...	J-13
190706	TWL 190 FL-BTSMQ w/P&C, 8,000 lbs. Support Cap., 15" Travel...	J-13
190708	Heavy Duty Jack, Tubular Swivel Mount (Includes Mating Mount...	J-13
190724	Heavy Duty Jack, Tubular Swivel Mount (Includes Pin and Chai...	J-13
190754	SWL 190 DL-BQ, 8,000 lbs. Support Cap., 15" Travel, Drop Leg...	J-13
1907540176	SWL 190 DL-BQ, 8,000 lbs. Support Cap., 15" Travel	J-13
190756	SWL 190 FL-BTSMQ w/P&C, 8,000 lbs. Support Cap., 15" Travel...	J-13
190758	SWL 190 DL-BTSMQ w/P&C, 8,000 lbs. Support Cap., 15" Travel...	J-13
190789	Heavy Duty Jack, Tubular Swivel Mount (Includes Mating Mount...	J-13
19306	1" High Rise, 2-5/16" Ball for Under-Bed Gooseneck Heads (Do...	G-10
19307	3" Ball for Under-bed Gooseneck Heads (Do Not Store Inverte...	G-10
19308	5" Offset Extension, 2-5/16" Ball for Under-bed Gooseneck He...	G-10
19309	2-5/16" Ball for Hide-A-Goose #9460, #9461, #9464, #9465 & U...	G-10
19310	Gooseneck Hitch Ball for DT #40845, DT #6002, HH #50845, HH ...	G-10
19311	2-5/16" Pop-In™ Ball for Elite™ Under-Bed Bolt-On Gooseneck ...	G-6
19314	3" Pop-In™ Ball for Elite™ Under-Bed Bolt-On Gooseneck Head...	G-6
19315	1" High Rise, 2-5/16" Pop-In™ Ball for Elite™ Under-Bed Bolt...	G-6
1935	Drill Bit Set, (1) 3/8", (1) 7/16", (1) 1/2"	A-11
1936	Hole Saw, 1"	A-11
1937	Hole Saw Arbor w/Pilot Drill Bit	A-11
1944	Receiver Tube Cover, 2" Sq, Chrome Plastic	B-23
195301	Heavy Duty Jack, Fixed Leg With Base	J-12
195304	TWL 195 DL-DXQ, 5,000 lbs. Support Cap., 15" Travel, No Mou...	J-12
195306	TWL 195 DTSFQ w/P&C, 5,000 lbs. Support Cap., 15" Travel, Ro...	J-12
195312	TWL 195 DTSXFQ w/P&C, 5,000 lbs. Support Cap., 15" Travel, S...	J-11, J-12
195318	TWL 195 DL-DFXQ, 5,000 lbs. Support Cap., 15" Travel, A-Fra...	J-12
195319	TWL 195 FL-BXQ, 5,000 lbs. Support Cap., 15" Travel, No Mou...	J-12
195320	TWL 195 FL-XQ, 5,000 lbs. Support Cap., 15" Travel, No Moun...	J-12
195321	Heavy Duty Jack, Fixed Less Base	J-12
195351	SWS 195 DQ, 5,000 lbs. Support Cap., 10" Travel, No Mount, ...	J-12
195352	Heavy Duty Jack, Fixed Leg with Base	J-12
195354	SWL 195 DL-DXQ, 5,000 lbs. Support Cap., 15" Travel, No Moun...	J-12
195356	SWL 195 DTSFQ w/P&C, 5,000 lbs. Support Cap., 15" Travel, Ro...	J-11, J-12
195362	SWL 195 DTSXFQ w/P&C, 5,000 lbs. Support Cap., 15" Travel, S...	J-12
195368	SWL 195 FL-XQ, 5,000 lbs. Support Cap., 15" Travel, No Moun...	J-12
195369	Heavy Duty Jack, Fixed Leg Less Base	J-12
1962	Safety Chain Loop, Class II/III, 5,000 lbs.	M-24
198100	Swivel Jack, Topwind, 10" Travel, Weld-On Tubular Mount, 7.0...	J-6
198150	Swivel Jack, Sidewind, 10" Travel, Weld-On Tubular Mount, 7...	J-6
198200	Swivel Jack, Topwind, 15" Travel, Weld-On Tubular Mount, 7.0...	J-6
198250	Swivel Jack, Sidewind, 15" Travel, Weld-On Tubular Mount, 7...	J-6
20000	Lockable Battery Case (Plastic) with Partition for Shur-Set ...	M-6
20005	Shur-Set III® All Polymer Lockable Breakaway System (Inclue...	M-5
20010	Shur-Set III® Lockable Breakaway System (Includes #2010 Nyl...	M-5
20015	Shur-Set III® All Polymer Lockable Breakaway System (with Ch...	M-5
20020	Shur-Set III® Lockable Breakaway System (with Charger) (Incl...	M-5
20034-025	Perm-A-Seal Butt Connectors, 14-16 Gauge, Blue (25 pack)	C-35
20035-025	Perm-A-Seal Butt Connectors, 10-12 Gauge, Yellow (25 pack)	C-35
20046	Mounting Bracket for 5-Flat Connectors	C-33
2005-A	Replacement Part, Cable and Brass Pin assembly for #2005 Switch	M-6
2005-B120	Breakaway Switch, 1-3 Axle	M-6
2005-P	Replacement Part, Breakaway Switch, 1-3 Axle	M-6
2009-A	Replacement Part, Cable and Brass Pin Assembly for #2009 Switch	M-6
2009-A-P	Replacement Part, Cable and Brass Pin Assembly for #2009 Switch	M-6
2009-B60	Breakaway Switch, Metal	M-6
2009-P	Breakaway Switch, Metal	M-6
2010-A	Replacement Part, Cable and Nylon Pin Assembly for #2010 Switch	M-6
2010-A-P	Replacement Part, Cable and Nylon Pin Assembly for #2010 Switch	M-6
2010-B125	Breakaway Switch, Nylon w/ Weldable Tab	M-6
2010-P	Breakaway Switch, Nylon w/ Weldable Tab	M-6
20112	4-Flat Dust Cover	C-18
20112-024	4-Flat Dust Cover (24 pack)	C-18
20114	4-Flat Car End Tester w/LED Display	C-37
20115	5-Flat Car End Tester w/ LED Display and Dust Cap	C-37

PART NO.	DESCRIPTION	PAGE NO.
20116	6-Way Car End Tester w/LED Display	C-37
20117	7-Way Flat Pin Car End Tester w/LED Display	C-37
20118	Cover, 5-Flat Connector	C-18
20118-024	Cover, 5-Flat Connector (24 pack)	C-18
20125	4-Flat to 7-Way Flat Pin U.S. Car Connector Adapter	C-31
20127	Replacement Part, Universal 12" Brake Control Plug for #5520...	D-10
20127-012	Replacement Part, Universal 12" Brake Control Plug for #5520...	D-10
20136	4-Flat to 5-Flat Connector Assembly	C-29
20141	7-Way Flat Pin to 5-Flat Adapter w/LED Lamp Out By-Pass for ...	C-29
20142	7-Way Flat Pin to 7-Flat Pin Adapter w/LED Lamp Out By-Pass ...	C-29
201431	6-Way Round Pin Connector/4-Flat Combo Adapter Harness w/Mou...	C-28
20144	7-Way Flat Pin Connector/4-Flat Combo Adapter Harness w/Moun...	C-28
20145	LED Circuit Tester	C-37
20145-010	LED Circuit Tester (10 pack)	C-37
20147	USCAR 7 Way Replacement Harness	C-26
20174	Light Kit For Railed Cargo Carrier Part #59108, #59109, #591...	I-7, I-12
2018	Post Mount Battery Box (Plastic) with Partition for Shur-Set...	M-6
20191	I-Stop™ IQ Electronic Brake Control, for 1 to 3 Axle Trailer...	D-7
20212	Mounting Bracket for 7-Way OEM Connectors, Includes Screws a...	C-33
20212-010	Mounting Bracket for 7-Way OEM Connectors (10 pack)	C-33
20223	7-Way Trailer Wiring Harness, U.S. Car Connector, 7'	C-26
20224	7-Way Trailer Wiring Harness, U.S. Car Connector, 4'	C-26
2023	12 Volt 5 Amp/Hr Sealed Lead Acid Battery for Shur-Set III™	M-6
2023-X	12 Volt 5 Amp/Hr Sealed Lead Acid Battery for Shur-Set III™	M-6
2024-07	DC to DC Heavy Duty Quick/Maintenance (Multi Stage) Charger ...	M-6
2024-07-S	DC to DC Heavy Duty Quick/Maintenance (Multi Stage) Charger ...	M-6
20250	4-Flat Wiring Kit, Contains 12" 16 ga. for Vehicles w/Factor...	C-14
2025-09	AC-to-DC Multi Stage Maintenance Charger	M-6
20251	4-Flat Wiring Kit w/Taillight Converter, Contains 72" 16 ga...	C-14
20252	4-Flat Wiring Kit, Contains 72" 16 ga. Car End Connector Uni...	C-14
2026	Shur-Set III® Breakaway System w/5 Amp/Hr Battery (Includes ...	M-5
2028	Shur-Set III® Breakaway System w/5 Amp/Hr Battery (with Char...	M-5
203111	Side Marker/Clearance Light Amber w/Reflex Lens w/Black Stud...	K-18, K-33
203113	Side Marker/Clearance Light Red w/Reflex Lens w/Black Stud-M...	K-33
203116	Side Marker/Clearance Light w/Reflex & 18" Pigtail, Red	K-33
203117	Side Marker/Clearance Light w/Reflex & 18" Pigtail, Amber	K-20, K-33
203131	Side Marker/Clearance Light Amber w/Reflex Lens w/Black Ear...	K-33
203133	Side Marker/Clearance Light Red w/Reflex Lens w/Black Ear-Mo...	K-33
20320	4-Flat to 6-Way Round Pin Connector Adapter	C-31
20320-012	4-Flat to 6-Way Round Pin Connector Adapter (12 pack)	C-31
20321	4-Flat to 7-Way Flat Pin Connector Adapter, Plastic	C-31
20321-012	4-Flat to 7-Way Flat Pin Connector Adapter, Plastic (12 pack)	C-31
20322	4-Flat to 7-Way Flat Pin Connector Adapter, Metal	C-31
203233	Side Marker/Clearance Light Amber w/White Stud-Mount Base, P...	K-31
203234	Side Marker/Clearance Light Red w/White Stud-Mount Base, PC ...	K-31
203235	Side Marker/Clearance Light Amber, PC Rated	K-34
203285	Side Marker/Clearance Light Amber w/White Ear-Mount Base, PC...	K-31
203286	Side Marker/Clearance Light Red w/White Ear-Mount Base, PC R...	K-31
203292	Clearance Lens #37 Amber w/Black Base and Wire	K-29
203293	Clearance Lens #37 Red w/Black Base and Wire	K-29
203294	Clearance Lens #37 Amber w/Chrome Base and Wire	K-29
203295	Clearance Lens #37 Red w/Chrome Base and Wire	K-29
203315	Red, Waterproof, Stainless Steel Bar	K-38
203380	Replacement Part, Clearance Light Module #30 Amber, 2"	K-30
203381	Replacement Part, Clearance Light Module #30 Red, 2"	K-30
203395	Replacement Part, Clearance Light Module #37 Amber	K-29
203396	Replacement Part, Clearance Light Module #37 Red	K-29, K-38
20501	Pulse Preventor for use w/All Electronic Brake Controls	D-10
20505	Wiring Kit for 2 to 4 Brake Control Systems, Includes 25 ft...	D-11
20506	Wiring Kit for 6 to 8 Brake Control Systems, Includes 25 ft...	D-11
2051	Replacement Part, Battery Box, All Polymer Lockable	M-6
2060066	Bow Cam buckle Tie Down, 1" x 36", 400 lbs. Load Capacity & 1...	I-35
2060166	Bow Cam buckle Tie Down, 1" x 36", 300 lbs. Load Capacity & 9...	I-35
2060266	Transom Retractable Ratchet Tie Down, 2" x 43", 600 lbs. Loa...	I-35
2060366	Transom Retractable Ratchet Tie Down, 2" x 43", 833 lbs. Loa...	I-35
2060466	Transom SureLok Cam buckle Tie Down, 2" x 43", 833 lbs. Loa...	I-35
2060766	Transom SureLok Cam buckle Tie Down, 2" x 48", 833 lbs. Loa...	I-35
2060866	Gunwale Max Grip Ratchet Tie Down, 2" x 10', 333 lbs. Load C...	I-35
2060966	Gunwale Max Grip Ratchet Tie Down, 2" x 13', 400 lbs. Load C...	I-35
2061266	Gunwale Max Grip Ratchet Tie Down, 2" x 10', 833 lbs. Load C...	I-35
2061366	Gunwale Max Grip Ratchet Tie Down, 2" x 13', 833 lbs. Load C...	I-35
2061466	Gunwale Max Grip Ratchet Tie Down, 2" x 16', 833 lbs. Load C...	I-35
2061566	Gunwale Max Grip Ratchet Tie Down, 2" x 20', 833 lbs. Load C...	I-35
2061766	Transom Retractable Ratchet Tie Down, 2" x 43", 833 lbs. Loa...	I-35
21501	Replacement Part, Snap-up Bracket w/Set Screw & Safety Pin	E-9, E-10, E-16, O-3, O-4
2178	Voyager®, AccuTrac® and Pod® Mounting Kit Bracket	D-10
221088	Replacement Part, Grommet - 2-1/2" Round Open Back Heavy Duty	K-23, K-30

PRODUCT NUMERICAL

PART NO.	DESCRIPTION	PAGE NO.
2211	Rubber Economy Receiver Tube Cover w/"D" Logo for 1-1/4" Sq...	B-23
221588	Replacement Part, Grommet, Rectangular (15 Series)	K-22, K-24, K-26, K-29
22200 0101	Coupler, Ball Size 2", 2" Tongue Mount Width, Straight Chann...	J-48
22200 0301	Coupler, Class II, 2" Ball, 2" Channel, 3500 lbs. - Zinc	J-48
22200 0317	Coupler, Class II, 2" Ball, 2" Channel, 3500 lbs. - Primed	J-48
222012	LENS,SMCL SLIM FIT AMB	K-25
22225	Replacement Part, 800 lbs. High-Performance Spring Bar & Tru...	E-9, O-3
22250 0101	Coupler, Ball Size 2", 2-1/2" Tongue Mount Width, Straight C...	J-48
22250 0301	Coupler, Class II, 2" Ball, 2-1/2" Channel, 3500 lbs. - Zinc	J-48
22250 0317	Coupler, Class II, 2" Ball, 2-1/2" Channel, 3500 lbs. - Primed	J-48
22300 0101	Coupler, Ball Size 2", 3" Tongue Mount Width, Straight Chann...	J-48
22300 0301	Coupler, Class II, 2" Ball, 3" Channel, 3500 lbs. - Zinc	J-48
22300 0317	Coupler, Class II, 2" Ball, 3" Channel, 3500 lbs. - Primed	J-48
223117	Side Marker/Clearance Light w/Reflex & 18" Pigtail, Amber	K-20, K-33
223210	LP Light Assy	K-40
22550	Tow Harness, Universal 7-Way Prep Kit, Including ModuLite® H...	C-6
23227	Replacement Part, 600 lbs. High-Performance Spring Bar & Tru...	O-3
23300 0301	Coupler, Class II, 2" Ball, 3" Channel - Holes on 3" Centers...	J-48
2423006	7-Function Submersible Under 80" Taillight, Left/Roadside	K-19
2423008	8-Function Submersible Over 80" Taillight, Left/Roadside	K-19
2423056	6-Function Submersible Under 80" Taillight, Right/Curbside	K-19
2423058	7-Function Submersible Over 80" Taillight, Right/Curbside	K-19
2423273	Pedestal Mount, Amber Marker/Turn - Amber Marker/Turn - Doub...	K-16
2423274	Pedestal Mount, Red Stop/Tail/Turn - Amber Marker/Turn - Dou...	K-16
2423275	Pedestal Mount, Red Stop/Tail/Turn - Single Sided - Black Back	K-16
2423283	7-Function Under 80" Combination Taillight #80 Series, Left/...	K-15
2423284	6-Function Under 80" Combination Taillight #80 Series, Right...	K-15
2423286	Replacement Part, Lens for Under 80" Combination Taillight #...	K-15, K-19
2423287	Replacement Part, Lens for Under 80" Side Marker Clearance L...	K-15, K-19
2423293	8-Function Over 80" Combination Taillight #80 Series, Left/R...	K-15
2423294	7-Function Over 80" Combination Taillight #80 Series, Right/...	K-15
2423297	Replacement Part, LENS SIDE REPL OVER 80 LENS	K-15, K-19
2471	Replacement Part, Wire Lock Pin 1/2", Used w/Tow Bar Bracket...	M-27
2489	Safety Chain, Class III, 30" Length	M-24
2523023	7-Function Submersible Under 80" Taillight, Left/Roadside	K-19
2523024	8-Function Submersible Over 80" Taillight, Left/Roadside	K-19
2523073	6-Function Submersible Under 80" Taillight, Right/Curbside	K-19
2523074	7-Function Submersible Over 80" Taillight, Right/Curbside	K-19
2527511	Submersible Under 80" Taillight Kit w/25" Harness (w/o Clear...	K-19
26002	Dual Cam HP Sway Control	E-2, E-14, O-9
26003	Sway Control Adapter Bracket for use w/Class III/IV 2" Sq. B...	E-14
26005	Sway Control Adapter Bracket for use w/Class II 1-1/4" Sq. D...	E-14
26660	Standard Friction Sway Control	E-14, O-8
2706	Ball Mount, 5,000 lbs. GTW (Drop Position) & 3,500 GTW (Rise...	B-8
271574	7-Function Taillight, Right/Curbside, LED Over 80" 3x8 Low P...	K-7
271575	8-Function Taillight, Left/Roadside, LED Over 80" 3x8 Low Pr...	K-7
271584	7-Function Taillight, Right/Curbside Waterproof	K-8
271584-01	7-Function Taillight, Right/Curbside w/3 Wire Pigtail	K-8
271585	8-Function Taillight, Left/Roadside Waterproof, LED Waterpro...	K-8
271585-01	8-Function Taillight, Left/Roadside w/3 Wire Pigtail, LED Wa...	K-8
271594	7-Function Taillight, Right/Curbside, LED Over 80" Wrap-Around	K-7
271595	8-Function Taillight, Left/Roadside, LED Wrap-Around	K-7
273006	LED Submersible Under 80" Combination Taillights, 7-Function...	K-10
273008	LED Over 80" Submersible Taillight, Left/Roadside	K-10
273056	LED Submersible Under 80" Combination Taillights, 6-Function...	K-10
273058	LED Over 80" Submersible Taillight, Right/Curbside	K-10
273560	LED 6" Oval, Grommet Mount, Courtesy Light, Clear	K-22
273561	LED 6" Oval, Grommet Mount, Stop/Tail/Turn, Red WP	K-9
273564	LED 6" Oval, Grommet Mount, Stop/Tail/Turn, Amber WP	K-9
273565	White Backup Light	K-9
2736	Ball Mount, 5,000 lbs. GTW, 1" Ball Hole, 12" Length, 3/4" R...	B-8
2736-006	Ball Mount, 5,000 lbs. GTW, 1" Ball Hole, 12" Length, 3/4" R...	B-8
2793	Ball Mount, 5,000 lbs. GTW, 1" Ball Hole, 10" Length, 6-3/4" ...	B-8
2793-002	Ball Mount, 5,000 lbs. GTW, 1" Ball Hole, 10" Length, 6-3/4" ...	B-8
281594	LED Waterproof Over 80" Wrap-Around Taillights, 7-Function Ta...	5, K-2, K-7
281595	LED Waterproof Over 80" Wrap-Around Taillights, 8-Function T...	5, K-2, K-7
2823283	7-Function Under 80" Combination Taillight #80 Series, Left/...	K-15
2823284	6-Function Under 80" Combination Taillight #80 Series, Right...	K-15
2823285	Trailer Light Kit w/25" Wire Harness, w/Rectangular Clearanc...	K-15
2823293	8-Function Over 80" Combination Taillight #80 Series, Left/R...	K-15
2823294	7-Function Over 80" Combination Taillight #80 Series, Right/...	K-15
283006	LED Submersible Under 80" Combination Taillights, 7-Function...	K-10
283056	LED Submersible Under 80" Combination Taillights, 6-Function...	K-10
28351	Invisi-Hitch™ Accessory Adapter Kit, Adapter (10-3/8" Length...	A-6, B-4, B-7
283561	LED Waterproof 6" Oval Grommet Mount Taillights Stop/Tail/Tu...	K-9
283564	LED Waterproof 6" Oval Grommet Mount Taillights Stop/Tail/Tu...	K-9
283565	LED Waterproof 6" Oval Grommet Mount Taillights Backup Light	K-9

PART NO.	DESCRIPTION	PAGE NO.
28451	Invisi-Hitch™ Drawbar Kit, Drawbar (2000 lbs. w/3/4" Ball Ho...	A-6, B-7
2850	Receiver Fabrication Part, 6" Combo Bar 2" Sq. ID, Unpainted	A-10
2851	Receiver Fabrication Part, 12" Combo Bar 2" Sq. ID, Unpainted	A-10
2852	Receiver Fabrication Part, 24" Combo Bar 2" Sq. ID, Unpainted	A-10
2853	Receiver Fabrication Part, 36" Combo Bar 2" Sq. ID, Unpainted	A-10
2854	Receiver Fabrication Part, 48" Combo Bar 2" Sq. ID, Unpainted	A-10
287512	LED Submersible Under 80" Combination Taillight Kit w/25" Wi...	K-10
2898	Receiver Fabrication Part, 18" Combo Bar 2" Sq. ID, Unpainted	A-10
2902500	Triple Strength Bungee Cord Assortment (10 piece) (2) 12", (...	I-32
2902600	Triple Strength Bungee Cord Assortment (5 piece) (1) 12", (1...	I-32
2923	Ball Mount Kit, 7,500 lbs. GTW, 1" Ball Hole, 8-1/2" Length...	B-8
2953	Ball Mount Kit, 7,500 lbs. GTW, 1" Ball Hole, 9" Length, 2-3...	B-8
30033	22K Fifth Wheel Hitch Assembly & 90 Degree Fifth Wheel Adapt...	F-11, F-16, O-17
30035-040	Fifth Wheel Rails and Installation Kit, Includes Brackets an...	F-19
30047	16K Fifth Wheel (Requires Rails & Installation Kit #30035)	F-2, F-12, F-16, O-14
30047A	Replacement Part, 16K Fifth Wheel Head w/Support	F-12
30048	Fifth Wheel Kwik-Slide® Slider Unit w/6 Rollers for 15K, 16K...	F-17
30051	16K Fifth Wheel w/Kwik-Slide (Requires Rails & Installation ...	F-12, F-16
30053	Fifth Wheel Starter Kit	F-18
30054	30K Low Profile Fifth Wheel Hitch	F-11, F-16
30055	Fifth Wheel Cover	F-18
3006	Receiver Fabrication Part, 6" Combo Bar 1-1/4" Sq. ID, Unpai...	A-10
30-073833	Clearance Light 2-3/4" Round Red Round w/Two Wire Constructi...	K-31
30-073834	Clearance Light 2-3/4" Round Amber Round w/Two Wire Construc...	K-31
30075	16K Fifth Wheel Hitch w/ Round Tube Slider (Rail Kit Sold Se...	F-12, F-16
30081	20K Fifth Wheel (Rail Kit Sold Separately)	F-10, F-16, O-16
30083	20K Fifth Wheel w/Round Slider Unit (Rail Kit Sold Separately)	F-10, F-16
30084	20K Fifth Wheel w/Kwik Slide Slider Unit (Rail Kit Sold Sepa...	F-10, F-16
30092	Pro Series™ Fifth Wheel Slider Unit w/4 Rollers for 15K, 16K...	F-17
30093	Pro Series™ 15K Fifth Wheel Hitch (Includes: Head, Head Supp...	F-15, F-16
30094	Pro Series™ 15K Fifth Wheel Hitch (Includes: Head, Head Supp...	F-15, F-16
30099	Pro Series™ 15K Fifth Wheel Hitch (Includes: Head, Head Supp...	F-15
30105	6 Pole Square Connector Kit, Male and Female Ends for Tent T...	C-20
30118	Pro Series™ 20K Fifth Wheel Hitch (Includes: Head, Head Supp...	F-13
30119	Pro Series™ 20K Fifth Wheel Hitch (Includes: Head, Head Supp...	F-13, F-16
30121	Pro Series™ 20K Fifth Wheel Hitch (Includes: Head, Head Supp...	F-13, F-16
30128	Pro Series™ 15K Fifth Wheel Hitch (Includes: Head, Head Supp...	F-15
30129	Pro Series™ 15K Fifth Wheel Hitch (Includes: Head, Head Supp...	F-15
30132	Pro Series™ 20K Fifth Wheel Hitch (Includes: Head, Head Supp...	F-13
30133	Pro Series™ 20K Fifth Wheel Hitch (Includes: Head, Head Supp...	F-13
30134	Replacement Part, Safety Chain Attachment (Qty. 1) for Elite...	G-6
30135	Replacement Part, Storage Bag for Elite™ Under-Bed Bolt-On G...	G-6
30136	Replacement Part, Hole Cover for Elite™ Under-Bed Bolt-On Go...	G-6
30137	Elite™ Series Under-Bed Gooseneck Accessories Kit (Includes: ...	G-2, G-6
30138	Elite™ Series Under-Bed Bolt-On Gooseneck Head with Pop-In™ ...	G-4
30140	Elite™ Series Under-Bed Gooseneck Accessories Kit, RAM OEM K...	G-6
30142	Elite™ Series Fifth Wheel 18K (Pre-Assembled) & 90 Degree Fi...	F-3, F-16, O-11
30143	Elite™ Series Fifth Wheel 25K (Pre-Assembled) & 90 Degree Fi...	F-3, F-16, O-11
30144	Elite™ Series Fifth Wheel 18K w/Slider Unit (Pre-Assembled) ...	F-3, F-16
30145	Replacement Part, Safety Chain Attachment (Qty. 1) for Elite...	G-6
30149	Elite™ Series Rail Kit Accessory, Plastic Bedliner Puck Adap...	F-5
30153	Reese Outboard Fifth Wheel Mounting Rails Only (10 - Bolt De...	F-8, F-16, F-19
30158	Elite™ Series Under-Bed Bolt-On Gooseneck Head with Pop-In™ ...	G-4
30-17-034	Replacement Part, Gasket (Foam) for #178 Clearance Light	K-32
30-17-814	Clearance Light #178 Red with White Base, No gasket	K-32
30-17-815	Clearance Light #178 Amber with White Base, No gasket	K-32
30416	Replacement Part, Fifth Wheel Handle Locking Latch for DT #6...	O-14, O-17
30439	Replacement Part, Installation Kit w/Hardware and Brackets f...	F-19, O-18
30579	Replacement Part, Fifth Wheel Actuating Handle/Rod for DT #6...	O-14, O-17
30-58-001	Clearance Light #58 Red w/White Base	K-31
30-58-002	Clearance Light #58 Amber w/White Base	K-31
30-58-007	Clearance Light #58 Clear w/White Base	K-31
30-58-010	Replacement Part, Clearance Light Lens #58 Red	K-31
30-58-012	Replacement Part, Clearance Light Lens #58 Amber	K-31
30-58-024	Replacement Part, Clearance Light #58 White Base	K-31, K-32
30-58-702	Replacement Part, Clearance Light Wedge Base Socket w/#194 Bulb	K-31, K-32
30-59-001	Clearance Light #59 Red with Reflex w/White Base	K-32
30-59-002	Clearance Light #59 Amber with Reflex w/White Base	K-32
30-59-003	Clearance Light #59 Red with Reflex w/Black Base	K-32
30-59-004	Clearance Light #59 Amber with Reflex w/Black Base	K-32
30-59-010	Replacement Part, Clearance Light Lens #59 Red	K-32
30-59-012	Replacement Part, Clearance Light Lens #59 Amber	K-32
30-59-054	Replacement Part, Gasket (Foam) for #58 & #59 Clearance Light	K-31, K-32
30-60-004	Cargo Dome Light w/Chrome Base	K-43
30-60-005	Utility Light w/Chrome Base	K-43

NUMERICAL

PRODUCT NUMERICAL

PART NO.	DESCRIPTION	PAGE NO.
30-62-000	License Plate Light, Mini Compact	K-39
30-62-002	License Light #62 w/Black Base & Bracket	K-39
30-62-003	License Light #62 w/ White Base & Bracket	K-39
30-62-030	License Plate Bracket	K-39
30-62-102	License Light #62 w/Black Base (No Bracket)	K-39
30-62-103	License Light #62 w/White Base (No Bracket)	K-39
30-72-100	License Plate Bracket, Heavy Duty	K-39
30727	Replacement Part, 15K, 16K & 20K Fifth Wheel Legs (Qty. 2)	F-12, O-14, O-16
30730	Replacement Part, 20K & 22K Fifth Wheel Base Assembly w/Adju...	F-11, O-17
30-76-028	Replacement Part, Interior Light Lens #76	K-43
30-76-123	Interior Light #76 Single with Lens & Switch	K-43
30-76-223	Interior Light #76 Double with Lens & Switch	K-43
30-76-243	Interior Light #76 Double with Lens & Dual Switch	K-43
30776	Replacement Part, Fifth Wheel Handle Spring (Qty. 1)	O-14, O-17
30-78-021	Replacement Part, Porch Light Lens #78 Clear	K-42
30-78-022	Replacement Part, Porch Light Lens #78 Amber	K-42
30-78-515	Porch Light #78 Clear w/Ash White #5 Base	K-42
30-78-516	Porch Light #78 Amber w/Ash White #5 Base	K-42
30-78-517	Porch Light #78 Clear w/Ash White #5 Base & Switch	K-42
30-78-518	Porch Light #78 Amber w/Ash White #5 Base & Switch	K-42
30-78-522	Porch Light #78 Clear w/Black Base	K-42
30-78-523	Porch Light #78 Amber w/Black Base	K-42
30-78-524	Porch Light #78 Clear w/Black Base & Switch	K-42
30-78-525	Porch Light #78 Amber w/Black Base & Switch	K-42
30-78-600	Porch Light #78 Clear w/Chrome Base	K-42
308 0217	Coupler, Ball Size 2" - 2 1/8" Hand-Wheel, Tongue Mount Cha...	J-48
30-84-001	Taillight #84 Recessed Double Horizontal Red, Backup - Coloni...	K-12
30-84-002	Taillight #84 Recessed Triple Horizontal Red, Red, Backup - C...	K-13
30-84-008	Taillight #84 Recessed Double Horizontal Red, Backup - Black...	K-12
30-84-009	Taillight #84 Recessed Triple Horizontal Red, Red, Backup - B...	K-13
30-84-057	Replacement Part, Bulb Double Filament for #84, #85, #86 & M...	K-11, K-12, K-13, K-18, K-44
30-84-075	Replacement Part, Taillight Screw for #84#, 85, #86 Series &...	K-11, K-12, K-13, K-28
30-84-103	Taillight #84 Recessed Triple Long Horizontal Red, Backup, Re...	K-13
30-84-104	Taillight #84 Recessed Triple Long Horizontal Red, Backup, Am...	K-13
30845	Elite™ Series Gooseneck	F-2, F-5, G-2, G-6
30-84-508	Taillight #84 Recessed Double Vertical Red, Backup - Black Base	K-12
30-84-509	Taillight #84 Recessed Triple Vertical Red, Red, Backup - Bl...	K-13
30-84-523	Taillight #84 Recessed Triple Vertical Red, Red, Backup - Wh...	K-13
30-84-527	Taillight #84 Recessed Double Red, Red - Black Base	K-12
30-84-529	Taillight #84 Recessed Double Red, Red w/Red Insert - Black ...	K-12
30-84-540	Taillight #84 Recessed Double Horizontal Red, Backup - White...	K-12
30-84-547	Taillight #84 Recessed Double Red, Red - White Base	K-12
30-84-554	Taillight #84 Recessed Triple Long Vertical Red, Backup, Amb...	K-13
30850	Sidewinder Wedge Kit, Pro Series™ 15K, 16K & 20K	H-9
30-85-002	Taillight #85 Recessed Triple Horizontal Mount Red, Red, Bac...	K-13
30854	Pro Series™ 16K Fifth Wheel Hitch w/Dual Jaw System (Include...	F-14
30855	Pro Series™ 16K Fifth Wheel Hitch w/Dual Jaw System (Include...	F-14, F-16
30857	Pro Series™ 16K Fifth Wheel Hitch w/Dual Jaw System (Include...	F-14, F-16
30-86-005	Clearance Light #86 Wrap-Around Red w/Colonial White Base	K-11
30861	Sidewinder Wedge Kit, Curt 16K	H-9
30-86-101	Taillight #86 Single Stop, Tail, Turn w/Black Base	K-11
30-86-103	Taillight #86 Single Vertical Mount Backup w/Black Base	K-11
30-86-107	Taillight #86 Single Front Amber Turn w/Black Base	K-11
30862	Pro Series™ 25K Fifth Wheel Hitch	F-12, F-16
30-86-202	Clearance Light #86 Wrap-Around Red w/Black Base	K-11
30-86-203	Clearance Light #86 Wrap-Around Amber w/Black Base	K-11
30863	Replacement Part, Center Section, Drop-In for RAM #30160	F-5
30864	Replacement Part, Fifth Wheel Base Arches, Drop-In for RAM #...	F-5
30865	Sidewinder Wedge Kit, Reese Titan Fifth Wheels	H-9
30866	Titan® 16K Fifth Wheel (Rail Kit Sold Separately)	F-7, F-16, O-13
30867	Titan® 20K Fifth Wheel (Rail Kit Sold Separately)	F-7, F-16, O-15
30-86-711	Replacement Part, Side Marker Clearance Light Lens #86 Wrap...	K-11, K-28
30-86-712	Replacement Part, Side Marker Clearance Light Lens #86 Wrap...	K-11, K-28
30869	Titan® 16K Fifth Wheel w/Round Tube Slider #50024 (Rail Kit ...)	F-7, F-16
30870	Titan® 20K Fifth Wheel w/Round Tube Slider #50024 (Rail Kit ...)	F-7, F-16
30871	Elite™ Series Fifth Wheel 26.5K (Pre-Assembled) & 90 Degree ...	F-2, F-3, F-16, O-12
30-90-021	Replacement Part, Bulb #921 for #75 Interior Lights (Qty. 1)	K-43, K-44
30-90-156	Replacement Part, Bulb #1156 Single Filament for #84, 85, 86...	K-11, K-12, K-13, K-14, K-16, K-43, K-44

PART NO.	DESCRIPTION	PAGE NO.
30-90-157	Replacement Part, Bulb #1157 Double Filament for #91, 92, 14...	K-14, K-15, K-16, K-19, K-20, K-44, L-4
30-92-001	Taillight Surface Mount #92 Red with White Base	K-14
30-92-002	Taillight Surface Mount #92 Red with Backup with White Base	K-14
30-92-003	Taillight Surface Mount #92 Red with License Bracket with Wh...	K-14
30-92-004	Taillight Surface Mount #92 Red with Backup & License Bracke...	K-14
30-92-012	Replacement Part, Taillight Lens for #30-92-001 & 106	K-14
30-92-044	Bezel 15 Degree for #92 Series with White Base	K-14
30-92-106	Taillight Surface Mount #92 Red with Black Base	K-14
30-92-107	Taillight Surface Mount #92 Red with Backup with Black Base	K-14
30-92-108	Taillight Surface Mount #92 Red with License Bracket with Bl...	K-14
30-92-109	Taillight Surface Mount #92 Red with Backup & License Bracke...	K-14
30-92-704	Replacement Part, Taillight Lens Red with Backup for #30-92-...	K-14
30-92-708	Replacement Part, Taillight Lens Red with License Bracket fo...	K-14
30-92-713	Replacement Part, Taillight Lens Red with Backup with Licens...	K-14
30-99-011	Clearance Light #99 Red	K-34
30-99-002	Clearance Light #99 Amber	K-34
30-99-010	Replacement Part, Clearance Light Lens #99 Red	K-34
30-99-012	Replacement Part, Clearance Light Lens #99 Amber	K-34
31016	Sidewinder Wedge Kit, Curt A16	H-2, H-9
31-2823285	Taillight Kit w/25' Wire Harness, w/Rectangular Clearance/Si...	K-15
3132	Automatic Transmission Cooler Hose, 25 ft.	M-28
31-407540	Trailer Light Kit LED Over 80" 3x8 Low Profile	K-7
31-407560	Trailer Light Kit LED 4x6 Low Profile	K-8
31-59-001	Clearance Light #59 Red with White Base	K-32
31-59-002	Clearance Light #59 Amber with White Base	K-32
31-59-010	Replacement Part, Clearance Light Lens #59 Red	K-32
31-59-012	Replacement Part, Clearance Light Lens #59 Amber	K-32
3176123	Single Light#76 w/Switch	K-43
31-78-531	Porch Light #78 Clear Lens w/White Base	K-42
31-78-532	Porch Light #78 Amber Lens w/White Base	K-42
31-84-010	Replacement Part, Red Taillight Lens for #84, #85, & #86	K-11, K-12, K-13
31-84-016	Replacement Part, Amber Taillight Lens for #84, #85, & #86	K-11, K-12, K-13
31-84-700	Replacement Part, Vertical Taillight Lens w/Clear Backup for...	K-11, K-12, K-13
31-84-711	Replacement Part, Horizontal Taillight Lens w/Clear Backup f...	K-11, K-12, K-13
31859	Pro Series™ 16K Fifth Wheel Hitch w/Dual Jaw System (Include...	F-14
31860	Pro Series™ 16K Fifth Wheel Hitch w/Dual Jaw System (Include...	F-14
31-86-101	Taillight #86 Single Stop-Tail-Turn w/Black Base	K-11
31-86-103	Taillight #86 Single Vertical Backup w/Black Base	K-11
31-92-001	Taillight Surface Mount #92 Red w/White Base	K-14
31-92-003	Taillight Surface Mount #92 Red with License Bracket w/White...	K-14
3194-S	Battery Post Adapter	C-36
31-99-001	Clearance Light #99 Red	K-34
31-99-002	Clearance Light #99 Amber	K-34
31-99-215	ID Light Bar Red, Incandescent (Mounting Holes Located Outbo...	K-38
32-003440	Clearance Light Amber	K-35
32-003441	Clearance Light Red	K-35
3214	Wt. Dist. Shank, 14,000 lbs. (GTW), 1,400 lbs. (TW), 14" Length	E-15
3215	Wt. Dist. Shank, 14,000 lbs. (GTW), 1,400 lbs. (TW), 11" Len...	E-2, E-15
323356	Reflector, Red w/Adhesive Back, w/Mounting Holes (4-3/8" x 1...	K-41
323357	Reflector, Amber w/Adhesive Back, w/Mounting Holes (4-3/8" x...	K-41
3280	Pole Tongue Adapter and Fastener Kit	E-16
33305H0301	Coupler, 5000 lbs., Class III, Zinc, 2" Ball, SPL Holes	J-48
3344	Wt. Dist. Shank, 14,000 lbs. (GTW), 1,400 lbs. (TW), 11" Len...	E-15
34-073833	Clearance Light Red Round w/Two Wire Construction & White Base	K-31
34-073834	Clearance Light Amber Round w/Two Wire Construction & White ...	K-31
34-106293	Replacement Part, Clearance Light Base, Chrome 2" Snap-Lock ...	K-22, K-24, K-29
34-108119	Replacement Part, Mounting Bracket, 6" Oval Taillight	K-9, K-17, K-22, K-35
34-108663	Replacement Part, Pigtail - 2 Wire w/18" Wire Lead	K-22, K-23, K-24, K-26, K-29, K-30, K-40
34141	Safety Chain Loop, Class IV, 10,000 lbs.	M-24
34-17-034	Replacement Part, Gasket (Foam) for #178 Clearance Light	K-32
34-17-808	Clearance Light #178 Red with White Base with Foam Gasket	K-32
34-17-809	Clearance Light #178 Amber with White Base with Foam Gasket	K-32
34-271585	8-Function Taillight, Left/Roadside, LED 4x6 Low Profile	K-8
34300 0301	Coupler, Class III, 2" Ball, 3" Channel, 5000 lbs. - Zinc	J-48
34300 0317	Coupler, Class III, 2" Ball, 3" Channel, 5000 lbs. - Primed	J-48
3442	Replacement Part, Sway Control Ball Mounting Bar	E-14

PRODUCT NUMERICAL

PART NO.	DESCRIPTION	PAGE NO.
34-58-001	Clearance Light #58 Red w/ White Base	K-31
34-58-002	Clearance Light #58 Amber w/ White Base	K-31
34-58-010	Replacement Part, Clearance Light Lens #58 Red	K-31
34-58-012	Replacement Part, Clearance Light Lens #58 Amber	K-31
34-58-702	Replacement Part, Clearance Light Wedge Base Socket w/#194 Bulb	K-31, K-32
34-59-001	Clearance Light #59 Red with White Base	K-32
34-59-002	Clearance Light #59 Amber with White Base	K-32
34-59-010	Replacement Part, Clearance Light Lens #59 Red	K-32
34-59-012	Replacement Part, Clearance Light Lens #59 Amber	K-32
34-59-054	Replacement Part, Gasket (Foam) for #59 Clearance Light	K-31, K-32
34600 0301	Coupler, Class IV, FASLOK, 6000 lbs. - Zinc	J-48
34-62-000	License Plate Light, Mini Compact	K-39
34-62-002	License Light #62 w/Black Base & Bracket	K-39
34-62-003	License Light #62 w/White Base & Bracket	K-39
34-62-030	License Plate Bracket	K-39
34-62-102	License Light #62 w/Black Base (No Bracket)	K-39
34-62-103	License Light #62 w/White Base (No Bracket)	K-39
34-72-100	License Plate Bracket, Heavy Duty	K-39
34-76-028	Replacement Part, Interior Light #76 Lens	K-43
34-76-123	Interior Light #76 Single with Lens	K-43
34-76-223	Interior Light #76 Double with Lens	K-43
34-76-243	Interior Light #76 Double with Lens with Dual Switch	K-43
34-78-021	Replacement Part, Porch Light #78 Lens Clear	K-42
34-78-022	Replacement Part, Porch Light #78 Lens Amber	K-42
34-78-515	Porch Light #78 Clear with White #5 Base	K-42
34-78-516	Porch Light #78 Amber with Ash White #5 Base	K-42
34-78-517	Porch Light #78 Clear with Ash White #5 Base & Switch	K-42
34-78-518	Porch Light #78 Amber with Ash White #5 Base & Switch	K-42
34-84-008	Taillight #84 Recessed Double Horizontal Mount Red, Backup w/...	K-12
34-84-009	Taillight #84 Recessed Triple Horizontal Mount Red, Red, Back...	K-13
34-84-010	Replacement Part, Taillight Lens #84, #85, & #86 Red	K-11, K-12, K-13
34-84-016	Replacement Part, Taillight Lens #84, #85, & #86 Amber	K-11, K-12, K-13
34-84-527	Taillight #84 Recessed Double Red, Red with Black Base	K-12
34-84-529	Taillight #84 Recessed Double Red, Red with Red Insert with ...	K-12
34-84-700	Replacement Part, Taillight Lens Horizontal #84, #85, & #86 ...	K-11, K-12, K-13
34-84-711	Replacement Part, Taillight Lens Vertical #84, #85, & #86 Cl...	K-11, K-12, K-13
34-85-750	Replacement Part, Taillight #84, #85, #86 Red w/Red Insert L...	K-12, K-13
34-86-101	Taillight #86 Single Stop-Tail-Turn - Black	K-11
34-86-103	Taillight #86 Single Vertical Backup - Black	K-11
34-86-202	Clearance Light #86 Wrap-Around Red w/Black Base	K-11
34-86-203	Clearance Light #86 Wrap-Around Amber w/Black Base	K-11
34-86-711	Replacement Part, Side Marker Clearance Light #86 Wrap-Aroun...	K-11, K-28
34-86-712	Replacement Part, Side Marker Clearance Light #86 Wrap-Aroun...	K-11, K-28
34-90-021	Replacement Part, Bulb #921 for #75 Interior Lights (Qty. 2)	K-43, K-44
34-92-001	Taillight Surface Mount #92 Red with White Base	K-14
34-92-002	Taillight Surface Mount #92 Red with Backup with White Base	K-14
34-92-003	Taillight Surface Mount #92 Red with License Bracket with Wh...	K-14
34-92-004	Taillight Surface Mount #92 Red with Backup & License Bracke...	K-14
34-92-012	Replacement Part, Taillight Lens Red for #30-92-001 & 106	K-14
34-92-704	Replacement Part, Taillight Lens Red with Backup for #30-92-...	K-14
34-92-708	Replacement Part, Taillight Lens Red with License Bracket fo...	K-14
34-92-713	Replacement Part, Taillight Lens Red with Backup with Licens...	K-14
34-99-001	Clearance Light #99 Red	K-34
34-99-002	Clearance Light #99 Amber	K-34
34-99-010	Replacement Part, Clearance Light Lens #99 Red	K-34
34-99-012	Replacement Part, Clearance Light Lens #99 Amber	K-34
3590	Class I 1-1/4" Drawbar Kit, Drawbar (2000 lbs. w/3/4" Ball H...	B-7
3591	Class I 1-1/4" Drawbar Kit, Drawbar (2000 lbs. w/3/4" Ball H...	B-7
3592	Class I 1-1/4" Drawbar Kit, Drawbar (2000 lbs. w/3/4" Ball H...	B-7
3593	Class I 1-1/4" Drawbar Kit, Drawbar (2000 lbs. w/3/4" Ball H...	B-7
3594	Class I 1-1/4" Drawbar Kit, Drawbar (2000 lbs. w/3/4" Ball H...	B-7
35SM28ZF	2500 lbs. Square Tube, Fixed Mount	J-37
36051	Class II Drawbar Kit, Drawbar (3500 lbs. w/3/4" Ball Hole 7"...	B-7
36053	Class II Drawbar Kit, Drawbar (3500 lbs. w/3/4" Ball Hole 9"...	B-7
36061	Class II Drawbar Kit, Drawbar (3500 lbs. w/3/4" Ball Hole 9"...	B-7
36063	Class II Drawbar Kit, Drawbar (3500 lbs. w/3/4" Ball Hole 11"...	B-7
36065	Class II Drawbar Kit, Drawbar (3500 lbs. w/3/4" Ball Hole 10"...	B-7
36071	Class II Drawbar Kit, Drawbar (3500 lbs. w/3/4" Ball Hole 7"...	B-7
36078	Class II Drawbar Kit, Drawbar (3500 lbs. w/3/4" Ball Hole 7"...	B-7
37-2075	BULLDOG 24" x 19.6" 2-Sided Aluminum Sign	TBD
38023	3000 20K Weld-On Receiver w/3" Sq. Dual Ball Mount, 2" & 2-5...	A-8
3808	Economy Circuit Tester	C-37
38124	4000 25K Weld-On Receiver w/3" Sq. Dual Ball Mount, 2" & 2-5...	A-8
38180	Super Titan®. Dual Ball Mount, 25,000 lbs. GTW/4000 lbs. TW...	B-13

PART NO.	DESCRIPTION	PAGE NO.
38186	Super Titan®, 3" Receiver Pintle Hook Mounting Plate, 9" Sha...	B-15
38208	4000 25K Bolt-On Receiver w/3" Sq. Dual Ball Mount, 2" & 2-5...	A-8
38211	3000 20K Weld-On Receiver w/3" Sq. Dual Ball Mount, 2" & 2-5...	A-8
38371	Replacement Part, T-Handle T-27 Torx Driver (Qty.2) Service ...	I-29
38373-001	Replacement Part, Service Kit Keys (Qty.4) for Roof Rack Loc...	I-29
38373-002	Replacement Part, Service Kit Keys (Qty.4) for Roof Rack Loc...	I-29
38373-003	Replacement Part, Service Kit Keys (Qty.4) for Roof Rack Loc...	I-29
38373-004	Replacement Part, Service Kit Keys (Qty.4) for Roof Rack Loc...	I-29
38373-005	Replacement Part, Service Kit Keys (Qty.4) for Roof Rack Loc...	I-29
38373-006	Replacement Part, Service Kit Keys (Qty.4) for Roof Rack Loc...	I-29
38373-007	Replacement Part, Service Kit Keys (Qty.4) for Roof Rack Loc...	I-29
38373-008	Replacement Part, Service Kit Keys (Qty.4) for Roof Rack Loc...	I-29
38373-009	Replacement Part, Service Kit Keys (Qty.4) for Roof Rack Loc...	I-29
38373-010	Replacement Part, Service Kit Keys (Qty.4) for Roof Rack Loc...	I-29
38373-011	Replacement Part, Service Kit Keys (Qty.4) for Roof Rack Loc...	I-29
38373-012	Replacement Part, Service Kit Keys (Qty.4) for Roof Rack Loc...	I-29
38373-013	Replacement Part, Service Kit Keys (Qty.4) for Roof Rack Loc...	I-29
38373-014	Replacement Part, Service Kit Keys (Qty.4) for Roof Rack Loc...	I-29
38373-015	Replacement Part, Service Kit Keys (Qty.4) for Roof Rack Loc...	I-29
38374-001	Roof Rack Accessory, Locks & Keys (Qty.4) for Roof Rack Lock...	I-29
38374-002	Roof Rack Accessory, Locks & Keys (Qty.4) for Roof Rack Lock...	I-29
38374-003	Roof Rack Accessory, Locks & Keys (Qty.4) for Roof Rack Lock...	I-29
38374-004	Roof Rack Accessory, Locks & Keys (Qty.4) for Roof Rack Lock...	I-29
38374-005	Roof Rack Accessory, Locks & Keys (Qty.4) for Roof Rack Lock...	I-29
38374-006	Roof Rack Accessory, Locks & Keys (Qty.4) for Roof Rack Lock...	I-29
38374-007	Roof Rack Accessory, Locks & Keys (Qty.4) for Roof Rack Lock...	I-29
38374-008	Roof Rack Accessory, Locks & Keys (Qty.4) for Roof Rack Lock...	I-29
38374-009	Roof Rack Accessory, Locks & Keys (Qty.4) for Roof Rack Lock...	I-29
38374-010	Roof Rack Accessory, Locks & Keys (Qty.4) for Roof Rack Lock...	I-29
38374-011	Roof Rack Accessory, Locks & Keys (Qty.4) for Roof Rack Lock...	I-29
38374-012	Roof Rack Accessory, Locks & Keys (Qty.4) for Roof Rack Lock...	I-29
38374-013	Roof Rack Accessory, Locks & Keys (Qty.4) for Roof Rack Lock...	I-29
38374-014	Roof Rack Accessory, Locks & Keys (Qty.4) for Roof Rack Lock...	I-29
38374-015	Roof Rack Accessory, Locks & Keys (Qty.4) for Roof Rack Lock...	I-29
38422	Replacement Part, Mounting Pads (Qty.4) Service Kit for #382...	I-29
38423	Replacement Part, Mounting Pads (Qty.4) Service Kit for #38316	I-29
38424	Replacement Part, Mounting Pads (Qty.4) Service Kit for #387...	I-29
38425	Replacement Part, Mounting Pads (Qty.4) Service Kit for #382...	I-29
38426	Replacement Part, Mounting Pads (Qty.4) Service Kit for #38441	I-29
38427	Replacement Part, Self-Adhesive Rubber Mounting Pads (Qty.4)...	I-29
38428	Replacement Part, Self-Adhesive Rubber Mounting Pads (Qty.4)...	I-29
38429	Replacement Part, Self-Adhesive Rubber Mounting Pads (Qty.4)...	I-29
38665-012	4 Terminal Relay, 12 Volt, 2007-Up Chevrolet Equinox, Pontia...	C-35
38666-010	4 Terminal Relay, Small, 12 Volt, 2004-Up Infiniti QX56, Nis...	C-35
38667-010	6 Terminal Relay, Large, 12 Volt, 2004-Up Infiniti QX56, Nis...	C-35
38735	Super Titan® Receiver Adapter, Reduces Receiver Tube From 3" ...	B-14
39072	AutoGlide Capture Plate, for Lippert 1621	F-18
39073	AutoGlide Capture Plate, for Lippert 1116 & 1716	F-18
39074	AutoGlide Capture Plate, for MORryde	F-18
40-00-002	Replacement Part, Pigtail - 2 Wire w/6" Wire Lead	K-22, K-23, K-24, K-26, K-29, K-30, K-40
40-00-003	Replacement Part, Pigtail - 3 Wire Sealed	K-8, K-9, K-17, K-22, K-35
40-00-004	Replacement Part, Pigtail - 3 Wire 90 Degree	K-7, K-8, K-9, K-17, K-22, K-35
40-00-005	Replacement Part, #58 Series LED Pigtail - 2 Wire	K-27
40-00-006	Replacement Part, Pigtail - 3 Wire, LED Round 4"	K-8
40-01-001	Replacement Part, Sealed 4" Round Red Stop,Tail,Turn	K-17
40-01-003	Replacement Part, Sealed 4" Round Clear Backup Light	K-17
40-01-020	Replacement Part, Grommet - Sealed 4" Round Taillight	K-8, K-17
40058-002	Towing Starter Kit, w/Quick-Loading 2" Sq. Ball Mount, 7,500...	B-9
40-06-001	Replacement Part, Sealed 6" Oblong Red Taillight	K-17
40-06-002	Replacement Part, Sealed 6" Oblong Amber Turn Light	K-17
40-06-020	Replacement Part, Grommet - Sealed 6" Oblong Taillight	K-9, K-17, K-22, K-35
40109	Rotabroach Hole Cutting Tool, 3/8" Diameter	A-11
40110	Rotabroach Hole Cutting Tool, 7/16" Diameter	A-11
401565	Clearance Light LED #99 Amber w/Type 302 Stainless Steel Har...	K-26
401566	Clearance Light LED #99 Red	K-26, K-37
401567	Light Bar LED w/Red Lens	K-2, K-37
401580	Replacement Part, LED 2" Amber Marker/Clearance Light, Base ...	K-24
401581	Replacement Part, LED 2" Red Marker/Clearance Light, Base & ...	K-24
401582	Replacement Part, Side Marker Clearance Light Module LED #38...	K-28
401583	Replacement Part, Clearance Light Module LED #38 Red	K-28
401584	Replacement Part, LED 6" Oval Taillight, Horizontal Mount (G...	K-9

PRODUCT NUMERICAL

PART NO.	DESCRIPTION	PAGE NO.
401585	Side Marker Clearance Light LED #58 Amber	K-27
401586	Side Marker Clearance Light LED #58 Red	K-27
401589	Replacement Part, 2" Round Grommet & 2 Wire Connector	K-23, K-30
401591	Replacement Part, 6" Oval Grommet & 3 Wire Connector	K-9, K-17, K-22, K-35
40200	Hollow Shank Ball Mount, 10,000 lbs. GTW, 1-1/4" Ball Hole, ...	B-10
40201	Hollow Shank Ball Mount, 10,000 lbs. GTW, 1-1/4" Ball Hole, ...	B-10
40202	Hollow Shank Ball Mount, 10,000 lbs. GTW, 1-1/4" Ball Hole, ...	B-10
40205	Hollow Shank Ball Mount, 10,000 lbs. GTW, 1-1/4" Ball Hole, ...	B-10
40206	Hollow Shank Ball Mount, 10,000 lbs. GTW, 1-1/4" Ball Hole, ...	B-10
40238-002	Towing Starter Kit, w/Quick-Loading 2" Sq. Ball Mount, 7,500...	B-9
40-30-001	Replacement Part, Clearance Light Sealed Module, #30 Red	K-30
40-30-002	Replacement Part, Clearance Light Sealed Module, #30 Amber	K-30
40-30-002	Replacement Part, Grommet - 2" Round Clearance Light	K-23, K-30
403025	Over 80" Submersible Taillight, Left/Roadside (Black)	K-20
403026	Taillight, Waterproof Low-Profile Over 80" - Left/Roadside	K-18
403075	Over 80" Submersible Taillight, Right/Curbside (Black)	K-20
403076	Taillight, Waterproof Low-Profile Over 80" - Right/Curbside	K-18
403080	Taillight, Sealed Oval Set (Module, Grommet & Harness)	K-17
403085	Replacement Part, Taillight Module for #003080	K-17
40330	Forged Ball Mount, 16,000 lbs. GTW, 1-1/4" Ball Hole, 8-1/2"...	B-10
40330-002	Forged Ball Mount, 16,000 lbs. GTW, 1-1/4" Ball Hole, 8-1/2"...	B-10
40331	Forged Ball Mount, 16,000 lbs. GTW, 1-1/4" Ball Hole, 9-1/4"...	B-10
40331-002	Forged Ball Mount, 16,000 lbs. GTW, 1-1/4" Ball Hole, 9-1/4"...	B-10
40332	Forged Ball Mount, 16,000 lbs. GTW, 1-1/4" Ball Hole, 10-1/4"...	B-10
40332-002	Forged Ball Mount, 16,000 lbs. GTW, 1-1/4" Ball Hole, 10-1/4"...	B-10
403336	Replacement Part, Waterproof Low-Profile Over 80" Taillight ...	K-18
403356	Replacement Part, Taillight Capsule, Bulb Replaceable	K-18
40342	Quick-Loading Ball Mount, 7,500 lbs. GTW, 1" Ball Hole, 8-1/...	B-8
40342-006	Quick-Loading Ball Mount, 7,500 lbs. GTW, 1" Ball Hole, 8-1/...	B-8
40343	Quick-Loading Ball Mount, 6,000 lbs. GTW, 1" Ball Hole, 10-1...	B-8
40343-006	Quick-Loading Ball Mount, 6,000 lbs. GTW, 1" Ball Hole, 10-1...	B-8
40344	Quick-Loading Ball Mount, 7,500 lbs. GTW, 1" Ball Hole, 9" L...	B-8
40344-006	Quick-Loading Ball Mount, 7,500 lbs. GTW, 1" Ball Hole, 9" L...	B-8
40345	Quick-Loading Ball Mount, 6,000 lbs. GTW, 1" Ball Hole, 11" ...	B-8
40345-006	Quick-Loading Ball Mount, 6,000 lbs. GTW, 1" Ball Hole, 11" ...	B-8
40346	Quick-Loading Ball Mount, 5,000 lbs. GTW, 1" Ball Hole, 9-1/...	B-8
40346-002	Quick-Loading Ball Mount, 7,500 lbs. GTW, 1" Ball Hole, 9-1/...	B-8
40-37-001	Replacement Part, Clearance Light Sealed Module, #37 Red	K-29, K-38
40-37-002	Replacement Part, Clearance Light Sealed Module, #37 Amber	K-29
40-37-020	Replacement Part, Clearance Light Base, Black 2" Snap-Lock, ...	K-22, K-24, K-29
40-37-401	Replacement Part, Clearance Light Sealed Module, #37 Red	K-29, K-38
40-37-402	Replacement Part, Clearance Light Sealed Module, #37 Amber	K-29
40376	Test Light	C-37
40-38-001	Replacement Part, Clearance Light Sealed Module, #38 Red	K-29
40-38-002	Replacement Part, Clearance Light Sealed Module, #38 Amber	K-29
40-38-004	Clearance/Side Light Red/Amber (No Base)	K-29
40-38-020	Replacement Part, Clearance Light Base 3-13/16" x 1-1/4", Bl...	K-28, K-29
40-38-025	Replacement Part, Double Clearance Light Black Base w/2 Wires	K-28, K-29
40381	Aluminum Ball Mount, 8,000 lbs. GTW, 1" Ball Hole, 9-7/8" Le...	B-10
40382	Aluminum Ball Mount, 8,000 lbs. GTW, 1" Ball Hole, 10-5/8" L...	B-10
40383	Aluminum Ball Mount, 8,000 lbs. GTW, 1" Ball Hole, 11-7/8" L...	B-10
40384	Aluminum Ball Mount, 6,000 lbs. GTW, 1" Ball Hole, 10-7/8" L...	B-10
40-40-004	Fender Mount Clearance Light #40 Red/Amber with Lexan Black ...	K-34
40-40-104	Fender Mount Clearance Light #40 Red/Amber	K-34
40-40-115	Fender Mount Clearance Light Bezel Only Base with Lens Adhesive	K-34
40-40-120	Two Light Fender Mount Bezel Only (Red/Amber #38 or #99 Series)	K-29, K-34
40443	Packaged Ball Mount, 6,000 lbs. GTW, 1" Ball Hole, 10-1/2" L...	B-8
40446	Packaged Ball Mount, 6,000 lbs. GTW, 1" Ball Hole, 9-1/2" Le...	B-8
40565	Towing Starter Kit, w/Interlock® (Hex) Feature Ball Mount 2" ...	B-9
40583-002	Towing Starter Kit, w/Quick-Loading 2" Sq. Ball Mount, 7,500...	B-9
40584-002	Towing Starter Kit, w/Quick-Loading 2" Sq. Ball Mount, 7,500...	B-9
40-60-001	Security/Utility Light 7" with Chrome Base	K-43
40-60-004	Security/Utility Light 7" with White Base	K-43
40602	Heavy-Duty Bracket Kit for DT #2480, HH #40601, RS #74950, T...	M-27
40604	Heavy-Duty Safety Chain Kit for DT #2480, HH #40601, RS #749...	M-24, M-27
40644-002	Towing Starter Kit, w/Quick-Loading 2" Sq. Ball Mount, 7,500...	B-9
407500	Standard Under 80" Trailer Light Kit w/20" Wire Harness (No ...	K-15
407515	Submersible Over 80" Taillight Kit w/Side Marker/Clearance L...	K-20
407530	LED Over 80" 3X8 Low Profile Waterproof 7-Function Taillight...	K-7
407535	LED Over 80" 3X8 Low Profile Waterproof 8-Function Taillight...	K-7
407540	LED Over 80" 3X8 Low Profile Waterproof Trailer Light Kit	K-2, K-7
407550	LED Waterproof 4X6 Low Profile 7-Function Taillight, Right/...	K-8
407555	LED Waterproof 4X6 Low Profile 8-Function Taillight, Left/R...	K-8
407560	LED Waterproof 4X6 Low Profile Taillight Kit	K-8
40-767758	LED Waterproof 6" Oval Surface Flange Mount Taillights w/Blau...	K-10
410101	Transmission Oil Cooler kit 3/4"H x 5"W x 12-3/4"L, Light Du...	M-28

PART NO.	DESCRIPTION	PAGE NO.
41011	Transmission Oil Cooler kit 3/4"H x 7-1/2" W x 12-3/4"L, Med...	M-28
41013	Transmission Oil Cooler kit 3/4"H x 7-1/2" W x 15-1/2"L, Hea...	M-28
41014	Transmission Oil Cooler kit 3/4"H x 10" W x 15-1/2"L, Extra ...	M-28
410191	Transmission Oil Cooler kit, Hi-Performance, 3/4"H x 4"W x 1...	M-28
41020	Transmission Oil Cooler kit, Hi-Performance, 3/4"H x 5-3/4"W...	M-28
411031	Transmission Oil Cooler Metal Strap Mounting Kit	M-28
41-30-001	Replacement Part, Clearance Light Sealed Module, #30 Red	K-30
41-30-002	Replacement Part, Clearance Light Sealed Module, #30 Amber	K-30
41310	Transmission Cooler, Hi-Performance, 3/4"H x 7-1/4"W x 11"L...	M-28
41311	Transmission Cooler, Hi-Performance, 3/4"H x 12"W x 11"L, Ex...	M-28
41312	Transmission Cooler, Hi-Performance, 1-1/2"H x 11"W x 11"L...	M-28
413560	Waterproof / Sealed Recessed Taillights #06 Series Taillight...	K-17
41-37-031	Clearance Light Sealed #37 Red with Black Base and Wire	K-29
41-37-032	Clearance Light Sealed #37 Amber with Black Base and Wire	K-29
41-38-031	Clearance Light Sealed #38 Red with Black Base and Wire Asse...	K-29
41-38-032	Clearance Light Sealed #38 Amber with Black Base and Wire As...	K-29
41405	Transmission Oil Cooler Nylon Tie Mounting Kit	M-28
414101	Transmission Cooler Line Fitting Kit, for use on 1983 or Lat...	M-28
41412	Transmission Cooler Line Fitting Kit, for 1987 & Later Jeep...	M-28
414151	Transmission Cooler Line Fitting Kit, 1983 & Later Ford, Lin...	M-28
414161	Transmission Cooler Line Fitting Kit, 1999 & Later Dodge Ful...	M-28
414181	Transmission Cooler Line Fitting Kit, 1996 & Later GM, Snap...	M-28
416088	Replacement Part, Taillight Oval Grommet	K-9, K-17, K-22, K-35
417515	Light & Wire Kit, Submersible Over 80" w/20" Harness	K-20
41990	Ultra Frame Receiver, Weld Together For Service Body Trucks...	A-7
41990-07	Ultra Frame Receiver, Weld Together For Service Body Trucks...	A-7
41990-16	Ultra Frame Receiver, Weld Together For Service Body Trucks...	A-7
41991	Ultra Frame Receiver, Weld Together For Service Body Trucks...	A-7
41991-07	Ultra Frame Receiver, Weld Together For Service Body Trucks...	A-7
41991-16	Ultra Frame Receiver, Weld Together For Service Body Trucks...	A-7
42-106858	LED Surface Mount Red 13" Waterproof ID Light Bar, 3 Diode, ...	K-37
42250	Ball Cover, 1-7/8" & 2", Black	B-24
42250-012	Ball Cover, 1-7/8" & 2", Black, Display Pkg. (12 pack)	B-24
42251	Ball Cover, 2-5/16", Black	B-24
42251-012	Ball Cover, 2-5/16", Black, Display Pkg. (12 pack)	B-24
423025	Over 80" Submersible Taillight, Left/Roadside (Black)	K-20
423075	Over 80" Submersible Taillight, Right/Curbside (Black)	K-20
4234	Safety Chain Loop, Class I, 2,000 lbs.	M-24
42-37-401	Replacement Part, 37 Series LED Red	K-24, K-37
42-37-402	Replacement Part, 37 Series LED Amber	K-24
42-38-033	Side Marker Clearance Light LED #38 Red with Black Base with...	K-28
42-38-034	Side Marker Clearance Light LED #38 Amber with Black Base wi...	K-28
42-38-035	Side Marker Clearance Light LED #38 Red/Amber w/Black Base, ...	K-28
42-59-401	Side Marker Clearance Light LED #59 Red w/White Base	K-27
42-59-402	Side Marker Clearance Light LED #59 Amber w/White Base	K-27
42-59-410	Side Marker Clearance Light, Upgrade Kit LED #59 Red	K-27
42-59-412	Side Marker Clearance Light, Upgrade Kit LED #59 Amber	K-27
4280	Ball Mount, 12,000 lbs. GTW, 1-1/4" Ball Hole, 8-1/2" Length...	B-11
4281	Ball Mount, 12,000 lbs. GTW, 1-1/4" Ball Hole, 8-1/2" Length...	B-11
4282	Ball Mount, 12,000 lbs. GTW, 1-1/4" Ball Hole, 9-1/2" Length...	B-11
4283	Ball Mount, 12,000 lbs. GTW, 1-1/4" Ball Hole, 9-1/2" Length...	B-11
4284	Ball Mount, 12,000 lbs. GTW, 1-1/4" Ball Hole, 12" Length, 1...	B-11
42-84-410	LED #84 Series Stop, Tail, Turn Light Lens Upgrade Module Re...	K-3
42-84-412	LED #84 Series Turn Light Lens Upgrade Module Amber w/Conne...	K-3
4285	Ball Mount, 12,000 lbs. GTW, 1-1/4" Ball Hole, 12" Length, 3...	B-11
42-86-101	Taillight LED #86 Single Stop, Tail, Turn with Black Base	K-4
42-86-410	LED Wrap-Around Side Marker Clearance Light Upgrade Module Red	K-3, K-28
42-86-412	LED Wrap-Around Side Marker Clearance Light Upgrade Module A...	K-3, K-28
42-99-215	Waterproof ID Bar LED, Red	K-37
42-99-401	Side Marker Clearance Light LED Red w/Stud Mounting & 12" Br...	K-26
42-99-402	Side Marker Clearance Light LED Amber w/Stud Mounting & 12" ...	K-26
43805W0317	Coupler, A-Frame Wedge-Latch, 8,000 lbs.	J-41, L-11
44-00-002	Replacement Part, Pigtail - 2 Wire w/ 6-1/2" Wire Lead	K-22, K-23, K-24, K-26, K-29, K-30, K-40
44-00-003	Replacement Part, Pigtail - 3 Wire Sealed	K-8, K-9, K-17, K-22, K-35
44-01-001	Replacement Part, Taillight Sealed Stop, Tail, Turn 4" Round	K-17
44-01-020	Replacement Part, Grommet - Sealed 4" Round Taillight	K-8, K-17
44-01-031	Taillight Sealed Stop, Tail, Turn 4" Round with Grommet and ...	K-17
44-06-001	Replacement Part, Taillight Sealed Stop, Tail, Turn 6" Oblong	K-17
44-06-002	Replacement Part, Taillight Sealed Amber Turn 6" Oblong	K-17
44-06-020	Replacement Part, Grommet - Sealed 6" Oblong Taillight	K-9, K-17, K-22, K-35
44-06-031	Taillight Sealed Stop, Tail, Turn 6" Oblong with Grommet and...	K-17
44-06-032	Taillight Sealed Amber Turn 6" Oblong with Grommet and Stand...	K-17

PRODUCT NUMERICAL

PART NO.	DESCRIPTION	PAGE NO.
44-06-041	Taillight Sealed Stop, Tail, Turn 6" Oblong with Grommet and...	K-17
44-06-042	Taillight Sealed Amber Turn 6" Oblong with Grommet and 90 De...	K-17
44125W0317	Coupler, A-Frame Wedge-Latch, 12,500 lbs.	J-41, L-11
44133	Quick-Link Chain Hook-Up, 3,500 lbs., 3/8"	M-25
44140	Safety Chain, Class III GVWR 5,000 lbs. 48", 1/4" Proof Coil...	M-24
44150	Safety Chain S-Hook, Class I, Breaking Strength 2,000 lbs.	M-25
44150W0317	Coupler, A-Frame Wedge-Latch, 15,000 lbs., Round Jack Hole	J-41, L-11
44150WH301	Coupler, A-Frame Wedge-Latch, 15,000 lbs., Round Jack Hole, ...	J-41, L-11
44150WQ317	Coupler, A-Frame Wedge-Latch, 15,000 lbs., Square Jack Hole,...	J-41, L-11
44153	Safety Chain S-Hook, Class III Breaking Strength 5,000 lbs.	M-25
44154	Clevis Slip Hook w/Latch, Grade 43, 1/4"	M-25
44155	Clevis Slip Hook w/Latch, Grade 43, 5/16"	M-25
44156	Clevis Slip Hook w/Latch, Grade 43, 3/8"	M-25
44157	Clevis Slip Hook w/Latch, Grade 43, 1/2"	M-25
44159	Clevis Slip Hook w/Latch, Grade 70, 5/16"	M-25
44163	Clevis Slip Hook w/Latch, Grade 70, 1/4"	M-25
44164	Clevis Slip Hook w/Latch, Grade 70, 3/8"	M-25
44200	Recessed Rope Ring, 1,200 lbs. for 3/8" Plywood	M-25
4420000317	Coupler Plate, 20,000 lbs. Cast - Primed	J-41, L-11
44201	Recessed Rope Ring, 1,200 lbs., 10 Ga. Steel D-Ring, .225 Di...	M-25
44202	Recessed Rope Ring w/Trim Ring, 1,000 lbs., 16 Ga. Steel, Zinc	M-25
4425000317	Coupler Plate, 25,000 lbs. Cast - Primed	J-41, L-11
44-30-001	Replacement Part, Clearance Light Sealed Module, #30 Red	K-30
44-30-002	Replacement Part, Clearance Light Sealed Module, #30 Amber	K-30
44-30-020	Replacement Part, Grommet - 2" Round Clearance/Marker Light	K-23, K-30
44-30-031	Clearance Light Sealed #30 Red with Grommet and 6-1/2" Pigtail	K-30
44-30-032	Clearance Light Sealed #30 Amber with Grommet and 6-1/2" Pig...	K-30
44305F0317	F2™ A-Frame Coupler, Ball Size 2-5/16", Rating 10,000 lbs.	J-33
44305R0317	Coupler, A-Frame, 10,000 lbs., Class IV, Prime, 2-5/16" Ball	J-48
44305R0500	Coupler, A-Frame, 10,000 lbs., Class IV, Oily, 2-5/16" Ball	J-48
44311H0301	Coupler, A-Frame, 11,000 lbs., Class IV, Zinc Coated, 2-5/16...	J-48
44314R0303	Coupler, A-Frame, 14,000 lbs., Class IV, Black Paint, 2-5/16...	J-48
44-37-020	Replacement Part, Clearance Light Base, Black 2" Snap-Lock, ...	K-22, K-24, K-29
44-37-031	Clearance Light Sealed #37 Red with Black Base and Wire	K-29
44-37-032	Clearance Light Sealed #37 Amber with Black Base and Wire	K-29
44-38-031	Clearance Light Sealed #38 Red with Black Base and Wire Asse...	K-29
44-38-032	Clearance Light Sealed #38 Amber with Black Base and Wire As...	K-29
44-40-004	Fender Mount Clearance Light #40 Red/Amber with Black Base a...	K-34
45018	Titan®, Receiver Extension, 2-1/2" to 2" Extension, 41" Leng...	B-14
45122	Titan®, Ball Mount, 2-1/2" Sq. Hollow Shank, 14,000 lbs. GTW...	B-11
45123	Titan®, Ball Mount, 2-1/2" Sq. Hollow Shank, 13,000 lbs. GTW...	B-11
45144	Titan®, 2-1/2" Sq. Receiver Tube Cover	B-24
45156	Titan®, Receiver Pintle Hook Mounting Plate, 2-1/2" Sq. Holl...	B-15
45291	Titan®, Ball Mount, 2-1/2" Sq. Hollow Shank, 13,000 lbs. GTW...	B-11
45292	Titan®, Receiver Extension, 2-1/2" to 2" Extension, 24" Leng...	B-14
45294	Titan®, Receiver Pintle Hook Mounting Plate, 2-1/2" Sq. Soli...	B-15
45322	Titan®, Ball Mount, 2-1/2" Sq. Solid Shank, 18,000 lbs. GTW/...	B-11
45323	Titan®, Ball Mount, 2-1/2" Sq. Solid Shank, 18,000 lbs. GTW/...	B-11
45325	Titan®, Tri-Ball Ball Mount, 2-1/2" Sq. Hollow Shank w/Black...	B-13
4655	9/16" Drill Bit w/Special 1/2" Reduced Shank for Use w/1/2" ...	A-11
47-01-001	Replacement Part, Taillight LED Stop, Tail, Turn 4" Round	K-8
47-01-031	4" Round LED Tail Lamp with Grommet and Plug	K-8
47-06-004	Replacement Part, Taillight LED Stop, Tail, Turn 6" Oval Hor...	K-9
47-06-005	6" Oval Mid-Turn Amber Light	K-35
47-06-034	6" Oval LED Tail Lamp w/Grommet and Plug, Horizontal Mount	K-9
47-06-404	Replacement Part, Taillight LED Stop, Tail, Turn 6" Oval Hor...	K-9
47-106020	Replacement Part, Chrome Bezel	K-25
47-106851	Side Marker Clearance Light LED Waterproof Amber w/Stud Mou...	K-26
47-106852	LED Waterproof Stud Mount Amber 162" 1 Wire Pigtail	K-26
47-106853	Clearance Light LED Waterproof Amber Lens w/Diodes	K-25
47-106854	Clearance Light LED Waterproof Clear Lens w/Amber Diodes	K-25
47-106857	LED Waterproof Stud Mount Amber 162" 2 Wire Pigtail	K-26
47-106858	LED ID Bar 60" 2 Wire Pigtail	K-37
47-107043	Side Marker Clearance Light LED Red w/Stud Mounting & 12" Br...	K-26
47-107044	LED Waterproof Stud Mount Red 96" 1 Wire Pigtail	K-26
47-107046	LED Waterproof Stud Mount Red 96" 2 Wire Pigtail	K-26
47-107047	Clearance Light LED Waterproof Red Lens w/Diodes	K-25
47-107048	Clearance Light LED Waterproof Clear Lens w/Red Diodes	K-25
47-203667	LED Waterproof Grommet Mt Amber	K-26
47-203668	LED Waterproof Grommet Mt Red	K-26
47-222012	Clearance Light LED Waterproof Amber w/Reflex w/Black Base	K-25
47-222014	Clearance Light LED Waterproof Red w/Reflex w/White Base	K-25
47-222015	Clearance Light LED Waterproof Amber w/Reflex w/White Base	K-25
47-37-001	Replacement Part, Clearance Light LED Module, #37 Red	K-24, K-37
47-37-002	Replacement Part, Clearance Light LED Module, #37 Amber	K-24
47-37-005	Clearance Light Module LED #37 Red	K-24
47-37-006	Clearance Light Module LED #37 Amber	K-24

PART NO.	DESCRIPTION	PAGE NO.
47-37-031	Red 2" LED Rectangular Marker/Clearance Lamp	K-24
47-37-032	Amber 2" LED Rectangular Marker/Clearance Lamp	K-24
47-37-401	Replacement Part, Clearance Light LED Module, #37 Red	K-24, K-37
47-37-402	Replacement Part, Clearance Light LED Module, #37 Amber	K-24
47-38-001	Replacement Part, Side Marker Clearance Light LED Module, #3...	K-28
47-38-002	Replacement Part, Side Marker Clearance Light LED Module, #3...	K-28
47-38-004	Side Marker Clearance Light Module LED #38 Red/Amber	K-28
47-38-033	Side Marker Clearance Light LED #38 Red with Black Base with...	K-28
47-38-034	Side Marker Clearance Light LED #38 Amber with Black Base wi...	K-28
47-38-401	Replacement Part, Side Marker Clearance Light LED Module, #3...	K-28
47-38-402	Replacement Part, Side Marker Clearance Light LED Module, #3...	K-28
47-54-001	Narrow Rail S,T,T Red w/Reflex	K-4
47-54-002	Narrow Rail ID Bar LED Red	K-38
47-54-003	Narrow Rail ID Bar LED Amber	K-38
47-58-001	Side Marker Clearance Light LED #58 Red	K-27
47-58-002	Side Marker Clearance Light LED #58 Amber	K-27
47-58-031	Side Marker Clearance Light LED #58 Red with Pigtail	K-27
47-58-032	Side Marker Clearance Light LED #58 Amber with Pigtail	K-27
47-59-001	Side Marker Clearance Light LED #59 Red w/White Base	K-27
47-59-002	Side Marker Clearance Light LED #59 Amber w/White Base	K-27
47-59-010	Side Marker Clearance Light LED Replacement Lens Red	K-27
47-59-012	Side Marker Clearance Light LED Replacement Lens Amber	K-27
47-59-401	Side Marker Clearance Light LED #59 Red w/White Base	K-27
47-59-402	Side Marker Clearance Light LED #59 Amber w/White Base	K-27
47-59-410	Side Marker Clearance Light, Upgrade Kit LED #59 Red	K-27
47-59-412	Side Marker Clearance Light, Upgrade Kit LED #59 Amber	K-27
47-84-001	Taillight Horizontal Mount with Red LED, Incandescent Backup...	K-5
47-84-005	Taillight Horizontal Mount with Red/Amber LED, Incandescent ...	K-6
47-84-008	Taillight Horizontal Mount with Red LED, Incandescent Backup...	K-5
47-84-009	Taillight Horizontal Mount with Red/Red LED, Incandescent Ba...	K-6
47-84-026	LED #84 Backup Lens Module Clear w/Bulb Socket Plug	K-3
47-84-103	Taillight Horizontal Mount with Red LED, Incandescent Backup...	K-6
47-84-104	LED Taillight #84 Recessed Triple Long Horizontal Mount, Red...	K-6
47-84-410	LED #84 Series Stop, Tail, Turn Light Lens Upgrade Module Re...	K-3
47-84-412	LED #84 Series Turn Light Lens Upgrade Module Amber w/Conne...	K-3
47-84-420	Replacement Part, LED #84 Series Stop, Tail, Turn Light Lens...	K-4, K-5, K-6
47-84-527	Taillight Red & Red LED with Black Base	K-5
47-84-529	Taillight Red LED & Incandescent Red with Red Insert & Black...	K-5
47-84-530	Taillight Horizontal Mount with Red/Red LED, Incandescent Ba...	K-6
47-84-540	Taillight Horizontal Mount with Red LED, Incandescent Backup...	K-5
47-84-610	Taillight #84 LED Surface Mount Red/Red, Black Base	K-5
47-84-711	Enhanced Height Incandescent Backup Lens Only, Red Reflex w/...	K-3, K-5, K-6
47-84-712	Enhanced Height Incandescent Backup Lens Only - Red Reflex w/Red Ce...	K-3, K-5, K-6
47-84-808	Taillight Horizontal Mount with Red LED, Incandescent Backup...	K-5
47-85-002	Taillight Horizontal Mount with Red/Red LED, Incandescent Ba...	K-6
47-85-004	Taillight Horizontal Mount with Red/Amber LED, Incandescent ...	K-6
47-85-611	Taillight #84 LED Surface Mount Red/Red Chrome Base	K-5
47-85-711	Enhanced Height Incandescent Backup Lens Only, Red Reflex w/...	K-3
47-86-101	Taillight LED #86 Single Stop, Tail, Turn with Black Base	K-4
47-86-202	Side Marker Clearance Light LED #86 Wrap-Around Red with Bla...	K-28
47-86-410	LED Wrap-Around Side Marker Clearance Light Upgrade Module Red	K-3, K-28
47-86-412	LED Wrap-Around Side Marker Clearance Light Upgrade Module A...	K-3, K-28
47-99-004	ID Light Bar LED Red	K-37
47-99-005	Clearance Light LED #99 Red w/Type 302 Stainless Steel Hardware	K-26, K-37
47-99-006	Clearance Light LED #99 Amber w/Type 302 Stainless Steel Har...	K-26
47-99-034	ID Light Bar LED Red	K-37
47-99-215	Waterproof ID Bar LED, Red	K-37
47-99-401	Clearance Light LED #99 Red	K-26
47-99-402	Clearance Light LED #99 Amber	K-26
48-84-008	Taillight Horizontal Mount with Red LED, Incandescent Backup...	K-5
48-84-009	Taillight Horizontal Mount with Red/Red LED, Incandescent Ba...	K-6
48-84-527	Taillight Red & Red LED with Black Base	K-5
48-84-529	Taillight Red LED & Incandescent Red with Red Insert & Black...	K-5
48-84-711	Enhanced #84/86 Incandescent Backup Lens	K-3, K-5, K-6
48-84-712	Enhanced Height Incandescent Lens Only - Red Reflex w/Red Ce...	K-3, K-5, K-6
48-85-711	Enhanced Height Incandescent Backup Lens Only, Red Reflex w/...	K-3
48-86-101	Taillight LED #86 Single Stop, Tail, Turn with Black Base	K-4
48-86-202	Side Marker Clearance Light LED #86 Wrap-Around Red with Bla...	K-28
4907	Ultra Frame Receiver, Weld Together For Service Body Trucks ...	A-7
49080	Pro Series™ Gooseneck (Requires Rails & Installation Kit #30...	F-17, G-10
49131	Quick-Link Chain Hook-Up, 3,500 lbs., 5/16"	M-25
49132	Quick-Link Chain Hook-Up, 3,500 lbs., 1/4"	M-25
49134	Quick-Link Chain Hook-Up, 5,000 lbs., 7/16"	M-25
49135	Quick-Link Chain Hook-Up, 10,000 lbs., 1/2"	M-25
49137	Safety Chain, Class I GVWR 2,000 lbs. 48", 3/16" Proof Coil,...	M-24
49138	Safety Chain, Class II GVWR 3,500 lbs. 24", 1/4" Proof Coil,...	M-24
49141	Safety Chain, Class III GVWR 5,000 lbs. 30", 1/4" Proof Coil,...	M-24
49147	Safety Chain, Class IV GVW 16,200 lbs. 35", 1/2" Proof Coil,...	M-24

PRODUCT NUMERICAL

PART NO.	DESCRIPTION	PAGE NO.
49148	Safety Chain, Class IV GVW 7,600 lbs. 32", 5/16" Proof Coil...	M-24
49149	Safety Chain, Class IV GVW 10,600 lbs. 36", 1/2" Proof Coil...	M-24
49150	Goose Box™ Accessory, Safety Chain Kit (Contains: (2) Grade ...	G-3, H-3
49151	Goose Box™ Accessory, 20K Safety Chain Kit (Contains: (2) Gr...	G-3, H-3
49152	Safety Chain S-Hook, Class IV Breaking Strength 7,600 lbs.	M-25
4916	Ultra Frame Receiver, Weld Together For Service Body Trucks ...	A-7
49568	Pro Series™ RB2 Wt. Dist. Kit w/#63970 Shank, 10,000 lbs. (G...	E-13, O-6
49569	Pro Series™ RB2 Wt. Dist. Kit w/#63970 Shank, 10,000 lbs. (G...	E-13, O-6
49570	Pro Series™ RB2 Wt. Dist. Kit w/#63970 Shank, 12,000 lbs. (G...	E-13, O-6
49581	Pro Series™ RB3 Wt. Dist. Kit w/Shank, Chains & Hardware, 10...	E-13
49582	Pro Series™ RB3 Wt. Dist. Kit w/Shank, Chains & Hardware, 10...	E-13
49583	Pro Series™ RB3 Wt. Dist. Kit w/Shank, Chains & Hardware, 10...	E-13
49585	Pro Series™ Trunnion Wt. Dist. Kit w/#63970 Shank, 10,000 lb...	E-12, O-7
49586	Pro Series™ Trunnion Wt. Dist. Kit w/#63970 Shank, 10,000 lb...	E-12, O-7
49587	Pro Series™ Trunnion Wt. Dist. Kit w/#63970 Shank, 12,000 lb...	E-12, O-7
49802	Fold Down License Plate Holder	A-12
49803	Assortment Installation Hardware Kit	A-11
49901	Pro Series™ Complete RB Wt. Dist. Kit w/Shank, Friction Sway...	E-12
49902	Pro Series™ Complete RB Wt. Dist. Kit w/Shank, Friction Sway...	E-12
49903	Pro Series™ Complete RB Wt. Dist. Kit w/Shank, Friction Sway...	E-12
49904	Pro Series™ Complete RB Wt. Dist. Kit w/Shank, Friction Sway...	E-12
5000-DX	Shoe and Lining Kit - Dexter 12" x 2" - Wheel Set	M-11, M-15, M-17
500103	Kit -3/8" Plunger Pin Assembly (2, 3, 5K)	J-28
500105	Sidewind Crank Assembly for 170's w/Black Knob	J-8, J-29
500106	Replacement Part, Bevel Gear Kit	J-30
500129	Service Kit -F2 Handle Holdup	J-32, J-33
500130	Service Kit -F2 Twin Track Wheel Replacement	J-32
500131	Service Kit -F2 Wide Track Wheel Replacement	J-32
500132	Service Kit -F2 Twin Track Wheel Wedge	J-32
500133	Service Kit -F2 Wide Track Wheel Wedge	J-32
500134	Service Kit -F2 Handle/Crank Kit	J-32, J-33
500135	Service Kit -F2 Gearbox Cover Replacement	J-32, J-33
500136	Service Kit -F2 Pull Pin Replacement	J-32
500137	Replacement Part, 2 Washers	J-32, J-33
500138	Service Kit -F2 Twin Track Wheel	J-32
500148	Replacement Part, Topwind Crank, 9" Radius w/Black "Tear Dro...	J-8, J-29
500153	Set Includes Direct Weld 2-Speed & Single Speed Jacks & Cran...	J-23
500154	Set Includes TMA Bold-On Mount 2-Speed & Single Speed Jacks...	J-23
500156	Replacement Part, Gear Kit 7,000 lbs.	J-30
500161	Fifth Wheel RV Landing Gear System, 10K Static, 10K Lift, Du...	J-24
500162	Fifth Wheel RV Landing Gear System, 8K Static, 4K Lift, Sing...	J-24
500171	Sidewind Crank Assembly for 190's, Black	J-8, J-29
500177	Kit, 3/4" Plunger Kit w/ Pin for 180's	J-28
500178	Replacement Part, 1/2" Plunger Pin Assembly for 800-5,000 lb...	J-28
500180	Replacement Part, Topwind Crank, 6-3/4" Radius w/Red Bulldo...	J-8, J-29
500187	Powered Drive Tongue Jack, A-Frame, 14" Travel, Black Case, ...	J-4
500188	Powered Drive Tongue Jack, A-Frame, 14" Travel, White Case, ...	J-4
500190	Replacement Part, Removable Disc Foot w/Snapper Pin for Bull...	J-3, J-4, J-28
500191	Replacement Part, Manual Override Bolt for Bulldog Powered D...	J-3
500193	Replacement Part, Level Assembly w/Hardware for Bulldog Powe...	J-3
500194	Replacement Part, Manual Override Cover for Bulldog Powered ...	J-3
500196	Replacement Part, LED Light Assembly for Bulldog Powered Dri...	J-3
500198	Powered Jack, A-Frame, 2.5K	J-4
500199	Powered Drive Tongue Jack, A-Frame, 22" Travel, Black Case, ...	J-2, J-3
5002	Shoe and Lining Kit - Dexter 7" x 1-1/4" - Wheel Set	M-10, M-17
500200	Powered Drive Tongue Jack, A-Frame, 22" Travel, White Case, ...	J-2, J-3
500201	Replacement Part, Manual Override Cover for Bulldog Powered ...	J-4
500202	Replacement Part, LED Light Assembly for Bulldog Powered Dri...	J-4
500203	Replacement Part, Manual Override Crank for Bulldog Powered ...	J-4
500204	Replacement Part, Drive Pin & Coupling for #500197, #500198	J-4
500205	Replacement Part, Gearbox Cover	J-30
500212	Replacement Part, Gear Kit Style III for 180's (1) Wear Pla...	J-30
500217	Replacement Part, Screw & Nut Kit -10K (PM NUT) (Contains: (...	J-30
500219	Lynch Pin Kit, 0.563" Diameter	J-28
500223	Kit, 5,000 lbs. Bearing for 170's	J-30
500224	Kit, 7,000 lbs. Bearing for 190's	J-30
500231	Kit, 5/8" Pull Pin, 3.5" Tall, w/Chain for 170's	J-28
500232	Kit, 5/8" Pull Pin, 4.25" Tall, w/Chain for 190's	J-28
500238	Weld-On Mount, Female, For 5/8" Pin, 3" O.D.	J-29
500239	Replacement Part, Swivel Trailer Mount, Tubular Male Weld-On...	J-8, J-29
50024	20K Fifth Wheel Round Tube Slider Unit (Requires Rails & Ins...	F-8
500240	Replacement Part, Swivel Trailer Mount, Tubular Male Weld-On...	J-29
500241	Swivel Retaining Ring for 800-5,000 lbs. Jacks	J-30
500242	Replacement Part, Swivel Bracket w/L-Bend	J-29
500243	Replacement Part, 9/16" Pull Pin w/12-1/4" Chain & Drive Scr...	J-28
500244	Replacement Part, Removable Disc Foot, 2-3/32" Tall w/Snappe...	J-8, J-28
500245	Tongue Jack Caster w/6" Wheel & Pin/Clip, for 2,000-5,000 lb...	J-27

PART NO.	DESCRIPTION	PAGE NO.
500246	Replacement Part, Red Knob for 150's, 160's & 170's	J-30
500248	Black Knob for 139's, 159's, 170's & 190's	J-30
500250	KIT SCREW/NUT-10K TW (J-30
500251	Kit, 2,000 lbs. Bearing for 150's	J-30
500256	Replacement Part, Sidewind Crank Kit, Handle, 5-51/64" Radiu...	J-8, J-29
5002581360	Kit-Gear for 190's	J-30
500265	Replacement Part, F2 Removable Twin Track Wheel Assembly	J-33
500266	Replacement Part, F2 Removable Wide Track Wheel Assembly	J-33
500267	Replacement Part, F2 Removable Foot Assembly	J-33
500268	Replacement Part, F2 Mounting Hardware for #1413250334, Incl...	J-33
500270	Replacement Part, 8K Dropleg & Pin	J-28
500276	Replacement Part, F2 4" x 5" Mount w/Hardware	J-32, P-11
500277	Replacement Part, F2 3" x 4" Mount w/Hardware	J-32, P-11
500285	Replacement Part, 12,000 lbs. 2 Speed Sun Gear	J-18, J-30
500286	Replacement Part, Mounting Hardware for Jacks	J-37
500289	Replacement Part, Repair Kit (BX1), Includes Handle Assembly...	J-45, L-15
500293	Replacement Part, Tandem Landing Gear Jack 90K Screw & Nut A...	J-23
500294	Replacement Part, Tandem Landing Gear Jack 90K Gear Assembly...	J-23
500295	Replacement Part, 2-Speed 12K Jack Gear Assembly Includes: ...	J-18
500296	Replacement Part, Gooseneck Couplers Set Bolt Kit, Includes:...	J-44, L-14
5003	Shoe and Lining Kit - Dexter 10" x 2-1/4" - Wheel Set	M-11, M-17
500305	Replacement Part, Black Cover w/Mounting Screws for Bulldog ...	J-4
500306	Replacement Part, White Cover w/Mounting Screws for Bulldog ...	J-4
500310	Pull Pin Assembly, 3/4" x 4"	J-28
500312	Replacement Part, Handle Clip	J-16, J-29
500314	Replacement Part, F2 Gear Kit, Includes: Shim Washer 5/16" (...	J-32
500315	Jack Accessory, Swivel Trailer Mount, Square Tube Male Weld...	J-8, J-29
500320	Jack Accessory, XP to F2 Adapter Kit, For F2 Swivel Mount w/...	J-32, J-37
500322	Replacement Part, End Cap, 2" for Round Tube EJ1000 & TJ1200...	J-37
500323	Replacement Part, End Cap, 2" for Round Tube XP10 Jacks	J-37
500324	Replacement Part, End Cap, 2.2" for Round Tube XP15 Jacks	J-37
500325	Replacement Part, End Cap, 2-1/4" for Square Tube HD2500 Jacks	J-37
500326	Replacement Part, End Cap for Bulldog 2,000 lbs. Sidewind Ro...	J-27
500329	KIT DROP LEG & PIN BT09 BULK/50	J-28
500330	Replacement Part, Planetary Gearbox Kit	J-18
5003341	Replacement Part, Pivot Pin 5/8" x 4-1/2" w/Cotter Pin & Lan...	J-49
5003351	Replacement Part, Pivot Pin 5/8" x 5-1/2" w/Cotter Pin & Lan...	J-49
5003361	Replacement Part, Pivot Pin 5/8" x 6-1/2" w/Cotter Pin & Lan...	J-49
500337	Replacement Part, Drop Leg Pull Pin Assembly, 3/4" x 3"	J-28
500338	Replacement Part, Drop Leg Pull Pin Assembly, 9/16" x 2.75"	J-28
500339	Jack Accessory, Swivel Trailer Mount, Round Tube Male Weld-O...	J-29
500340	Replacement Part, Drop Leg Pull Pin Assembly, 7/8" x 2.25"	J-28
500341	Replacement Part, 7/8" Pin & Chain w/ Drive Screw	J-28
500344	Replacement Part, 12" Topwind Handle for 10K Square Jack	J-29
500349	Replacement Part, Bolt on Mounting Kit for XP Series Jacks	J-37
500350	Replacement Part, Top Cover for F2 FW1600, FW2000 & FW3200 W...	J-52
500351	Replacement Part, Back Cover for F2 FW2000 & FW3200 Winches	J-52
500353	Replacement Part, Repair Kit (BX1, 3" Ball), Includes Handle...	J-45, L-15
500354	Replacement Part, Coupler Cap Spring	J-40
500356	Gooseneck Coupler Accessory, 5/16" Locking Pin for BX1 Goose...	J-45, L-15
500357	Replacement Part, Handle Kit for #KR10000301, KR15000301	J-58
500358	Replacement Part, Cap for BGR20 0101	M-22
500359	Replacement Part, Dual Output Motor for 500161 & 500170	J-24
500360	Replacement Part, Black Cover w/Mounting Screws for Bulldog ...	J-3
500361	Replacement Part, White Cover w/Mounting Screws for Bulldog ...	J-3
500362	Replacement Part, Light Switch for #500187, #500188, #500199...	J-3, J-4
500363	Replacement Part, Extend/Retract Switch for #500187, #500188...	J-3, J-4
500365	Replacement Part, Pull Pin for #141132 and #141133	J-34
500366	Replacement Part, Cable Keeper for #KR10000301, KR15000301	J-58
500367	Replacement Part, Drop Leg and Foot Plate for 500161 & 500170	J-24
500368	Replacement Part, Control Switch for 500158, 500161, 500162...	J-24
500370	Replacement Part, Powered Single Speed Drive Motor for 18242...	J-19
500372	Jack Accessory, Velocity Series™ High Speed Jack Single Remote	J-21
500374	Replacement Part, Foot Plate for Velocity Series™ #185400	J-21
500375	Replacement Part, Cover Kit for Velocity Series™ #185400	J-21
500376	Replacement Part, Contactor kit for Velocity Series™ #185400	J-21
500377	Jack Accessory, Drop Leg Pull Pin Assembly	J-28
500379	Jack Accessory, Velocity Series™ High Speed Jack Tandem Remote	J-21
500380	Jack Accessory, Velocity Series™ High Speed Jack 3 Pin Conne...	J-21
500382	Jack Accessory, Velocity Series™ High Speed Jack Channel Ada...	J-21
500386	Jack Accessory, Velocity Series™ High Speed Jack Single Remote	J-21
500400	DC Electric Utility Winch DC2500, 2500 lbs., w/Rope and Remote	J-60
500401	DC Electric Utility Winch DC3500, 3500 lbs., w/Rope and Remote	J-60
500402	DC Electric Utility Winch DC4500, 4500 lbs., w/Rope and Remote	J-60
500403	DC Electric Heavy Duty Winch DC6000, 6000 lbs.	J-2, J-61, J-62
500404	DC Electric Heavy Duty Winch DC9000, 9000 lbs.	J-61, J-62
500405	DC Electric Heavy Duty Winch DC12000L, 12,000 lbs.	J-61, J-62

PRODUCT NUMERICAL

PART NO.	DESCRIPTION	PAGE NO.
500407	DC Electric Heavy Duty Winch DC15000, 15,000 lbs.	J-61, J-62
500408	DC Electric Heavy Duty Winch DC18000, 18,000 lbs.	J-61, J-62
500410	DC Electric Hoist DCH650, 650 lbs.	J-64
500411	DC Electric Hoist DCH800, 800 lbs.	J-64
500412	DC Electric Hoist DCH1200, 1200 lbs.	J-64
500413	Hydraulic Winch HW8000, 8000 lbs.	J-63
500414	Hydraulic Winch HW12000, 12,000 lbs.	J-63
500415	Hydraulic Winch HW15000, 15,000 lbs.	J-63
500423	DC Electric Heavy Duty Winch DC6000, 6000 lbs., w/Rope	J-61
500424	DC Electric Heavy Duty Winch DC9000, 9000 lbs., w/Rope	J-61
500426	DC Electric Heavy Duty Winch DC12000L, 12,000 lbs., w/Rope	J-61
500516	Electric Winch Accessory, 9/32" x 80' Wire Rope	J-56
500520	Electric Winch Accessory, Galvanized Aircraft A7x19, 3/8" x 82'	J-56
500522	Electric Winch Accessory, Galvanized Aircraft A7x19, 3/8" x ...	J-56
500524	Replacement Part, Hawse Fairlead 112MM for 6K Electric Winch	J-65, J-66
500525	Replacement Part, Hawse Fairlead 184MM for 9K and 12K Electr...	J-65, J-66
500526	Winch Accessory, Electric Winch Wireless Remote, 6 Pin	J-65
500527	Winch Accessory, Electric Winch Wireless Remote, 3 Pin	J-21, J-65
500528	Winch Accessory, Electric Winch Wired Remote, 3 Pin	J-65
500529	Winch Accessory, Electric Utility Winch Wired Remote, 3 Pin	J-65
500530	Winch Accessory, Electric Winch Wired Remote, 6 Pin	J-65
500532	Replacement Part, Tie Rod Kit for 6K Electric Winch	J-65, J-66
500533	Replacement Part, Tie Rod Kit for 9K & 12KL Electric Winch	J-65, J-66
500534	Replacement Part, Tie Rod Kit for 12 - 18K Electric Winch	J-65, J-66
500536	Replacement Part, Cable Tensioner for 12k-15k Electric Winches	J-65, J-66
500537	Replacement Part, Cable Tensioner for 18k Electric Winches	J-65
500538	Replacement Part, Cable Tensioner for 8k-15k Hydraulic Winches	J-65, J-66
500539	Replacement Part, Roller Fairlead 63MM for #500400, #500401 ...	J-65, J-66
500540	Replacement Part, Roller Fairlead 190MM for #500403 & #500423	J-65, J-66
500541	Replacement Part, Roller Fairlead 1210MM for #500404 & #500405	J-65, J-66
500542	Replacement Part, Roller Fairlead 180MM for #500406, #500407...	J-65, J-66
500544	Replacement Part, Roller Fairlead 245MM for #500414 & #500415	J-65, J-66
500545	Replacement Part, Electric Contactor Kit for #500403, #50041...	J-65, J-66
500546	Replacement Part, Electric Contactor Kit for #500404, #50040...	J-65, J-66
500547	Replacement Part, Electric Contactor Kit for #500408	J-65, J-66
500549	Winch Replacement Part	J-65, J-66
500550	Replacement Part, Wire Rope Kit 3/16" x 50' for #500400	J-65, J-66
500551	Replacement Part, Wire Rope Kit 7/32" x 50' for #500401	J-65
500552	Replacement Part, Wire Rope Kit 1/4" x 50' for #500402	J-65
500600	DC Electric Utility Winch DC9.0, 9000 lbs. w/Wire Rope	5, J-2, J-59
500601	DC Electric Utility Winch DC12.0, 12,000 lbs. w/Wire Rope	J-59
500705	Fold-Away Replacement Part	J-49
5009	Shoe and Lining Kit - Dexter 10" x 1-1/2" - Axle Set	M-10, M-17
5010	Shoe and Lining Kit - Dexter 12" x 2" 7K - Wheel Set	M-12, M-17
501001	ROPE KEEPER CLAM 12/PKG	J-58
501101	11" WINCH HANDLE BAGGED 6/PKG	J-54, J-58
501103	6" WINCH HANDLE BAGGED 6/PKG	J-54
501106	8" WINCH HANDLE BAGGED 6/PKG	J-54
501107	7" WINCH HANDLE BAGGED 6/PKG	J-54
501108	10" WINCH HANDLE 6/PKG	J-54, J-56, J-58
501109	9" WINCH HNDL BULK/250	J-54
501110	10" WINCH HANDLE W/CLIP BAGGED 6/PKG	J-54, J-56
501115	Winch Replacement Part	J-58
501116	Winch Replacement Part	J-58
501117	Winch Replacement Part	J-58
501118	Winch Replacement Part	J-58
501121	Winch Replacement Part	J-58
501122	Winch Replacement Part	J-58
501124	Winch Replacement Part	J-58
501125	Winch Replacement Part	J-58
501130	Winch Replacement Part	J-58
501131	Winch Replacement Part	J-58
501132	Winch Replacement Part	J-56
501133	Winch Replacement Part	J-56
501134	Winch Replacement Part	J-56
501135	Winch Replacement Part	J-56
501201	WINCH STRP/HK 2"X20' LG HOOK BULK/20	J-54, J-56
501202	WINCH STRP/HK 2"X20'	J-54, J-56
501205	WINCH STRAP 20' COUNTER DISPLAY BOX/12	J-54, J-56
501207	WINCH STRP/HK 1.88"X20' 6/CARTON	J-54, J-56
501208	WINCH STRP/HK 2"X12' 6/CARTON	J-54, J-56
501209	Winch Replacement Part	J-54
50223	Fifth Wheel Chain Bracket Kit, 18,000 lbs.	F-18
50-57-007	7-Way Metal Connector, Trailer End	C-21
50-57-503	7-Way Metal Connector, Car End	C-21
50-61-008	6-Way Molded Trailer End w/ 8' Cable, 3-10 Gauge, 3-14 Gauge	C-20
50-61-104	6-Way Molded Trailer End w/ 4' Cable, 6-14 Gauge	C-20

PART NO.	DESCRIPTION	PAGE NO.
50-61-106	6-Way Molded Trailer End w/ 6' Cable, 6-14 Gauge	C-20
50-61-108	6-Way Molded Trailer End w/ 8' Cable, 6-14 Gauge	C-20
50-67-001	7-Way Molded Trailer End w/ 6' Cable	C-22
50-67-002	7-Way Molded Trailer End w/ 7' Cable	C-22
50-67-003	7-Way Molded Trailer End w/ 8' Cable	C-22
50-67-004	7-Way Molded Trailer End w/ 9' Cable	C-22
50-67-005	7-Way Molded Trailer End w/ 10' Cable	C-22
50-67-007	7-Way Molded Trailer End w/ 12' Cable	C-22
50-67-103	7-Way Molded Trailer Cord w/15ft. Cable	C-22
50-67-106	7-Way Molded Trailer Cord w/18ft. Cable	C-22
50-67-210	Double Ended 7-Way Molded Trailer End w/ 8' Cable	C-22
50-67-410	7-Way Molded Trailer End w/ 10' Cable and Breakaway Switch	C-22
50-67-614	7-Way Molded Trailer End w/ 4' Cable	C-24, L-6
50-67-616	7-Way Molded Trailer End w/ 6' Cable	C-24, L-6
50-67-618	7-Way Molded Trailer End w/ 8' Cable	C-24, L-6
50-67-620	7-Way Molded Trailer End w/ 10' Cable	L-6
50-67-901	Double Ended 7-Way Molded Trailer Cord w/ 6' Cable	C-22
50-67-907	7-Way Molded Trailer Cord w/4ft. Cable	C-22
50-76751	6" Red Oval LED Surface Mount Light w/Black Flange Base	K-10
50-76752	6" Red Oval LED Surface Mount Light w/Black Flange Base	K-10
50-77-001	7-Way Plastic Connector, Car End	C-21
50-77-003	7-Way Plastic Connector, Trailer End	C-21
50-77-070	7-Way Mounting Bracket	C-32
50-77-071	7-Way Mounting Bracket	C-32
50-77-0751	7-Way / 5-Flat Mounting Bracket	C-32
50-85-002	Replacement Part, 48" Cable for Breakaway Switch #50-85-007	M-6
50-85-007	Breakaway Switch w/48" Cable and Pin Assembly	M-6
50-85-102	Replacement Part, Battery Box	M-6
50-85-104	Accelerated Battery Charging Device (ABCD)	M-6
5085115	Accessory Part, Post Mount Bracket Kit for Breakaway Kits #5...	M-3, M-4
50-85-302	Breakaway System for 1 to 3 Axle Trailers w/Electric Brakes,...	M-4
50-85-312	Breakaway System w/ABCD for 1 to 3 Axle Trailers w/Electric ...	M-4
50-85-313	Breakaway System for 1 to 3 Axle Trailers w/Electric Brakes,...	M-2, M-3
50-85-315	Breakaway System for 1 to 3 Axle Trailers w/Electric Brakes,...	M-3
50-85-320	Breakaway System w/ABCD charger for 1 to 3 Axle Trailers w/E...	M-3
50-85-325	Breakaway System for 1 to 3 Axle Trailers w/Electric Brakes,...	M-3
508572	Plastic Fender, 12" Tire Size, White, w/S w/UPC	M-21
508573	Plastic Fender, 13" Tire Size, White, w/UPC LBL	M-21
508574	Plastic Fender, 14" Tire Size, White, w/S w/UPC	M-21
50-86-004	6-Way Super Sealed Car End w/ 4' Cable	C-20
50-86-007	6-Way Super Sealed Car End w/ 7' Cable	C-20
50-87-002	7-Way Super Sealed Car End w/ 2' Cable	C-21
50-87-004	7-Way Super Sealed Car End w/ 4' Cable	C-21
50-87-007	7-Way Super Sealed Car End w/ 7' Cable	C-21
50-87-009	7-Way Super Sealed Car End w/ 9' Cable	C-21
50-97-407	Right Angle 7-Way Molded Car End w/ 7' Cable	C-25
50-98-003	6 & 7-Way Plug Holder	C-34
50-98-050	7-Way Blade to 4-Flat Adapter	C-28
50-98-051	7-Way Blade to 6-Way Round Pin (Auxiliary in Center) Adapter	C-28
50-98-052	7-Way Round Pin to 4-Flat Adapter	C-28
50-98-054	6-Way Round Pin to 4-Flat Adapter	C-28
5100	Activator® Electronic Brake Control, for 1 to 2 Axle Trailer...	D-8
5101-HA	Magnet Kit - Hayes 10" x 1-5/8" & 2-1/4" and 12" x 2", 1994 ...	M-12, M-13, M-16, M-17
5106	Magnet Kit - Dexter 10" x 2-1/4" / Hayes 10" x 2-1/4" & 1-5/...	M-11, M-12, M-13, M-16, M-17
5109	Magnet Kit - Dexter or Hayes 12" x 2", After Late 1987 thru ...	M-11, M-13, M-16, M-17
5113	Magnet Kit - Dexter 10" x 1-1/2" or 7" x 1-1/4", After 4/1990	M-10, M-16, M-17
5114	Magnet Kit - Dexter 12" x 2", 7K Prior to Mid 1985	M-12, M-16, M-17
5118	Magnet Kit - Dexter 10" x 1-1/2", After Mid 1988	M-10, M-16, M-17
51-20036	4-Flat to 5-Flat Adapter	C-28
5120TEK	Magnet Retaining Ring	M-17
5121TEK	Magnet Retaining Clip	M-17
5122	Wire Clip	M-17
51-67-001	7-Way Molded Trailer End w/ 6' Cable	C-22
51-67-003	7-Way Molded Trailer End w/ 8' Cable	C-22
51-67-210	Double Ended 7-Way Molded Trailer Cord w/ 8' Cable	C-22
51-86-007	6-Way Super Sealed Car End w/ 7' Cable	C-20
51-87-002	7-Way Super Sealed Car End w/ 2' Cable	C-21
51-87-004	7-Way Super Sealed Car End w/ 4' Cable	C-21
51-87-007	7-Way Super Sealed Car End w/ 7' Cable	C-21
51-97-407	Right Angle 7-Way Molded Car End w/ 7' Cable	C-25
52 0801	Replacement Part, Coupler Repair Kit for Hand Wheel Coupler	J-48

PRODUCT NUMERICAL

PART NO.	DESCRIPTION	PAGE NO.
5280	Primus™, Envoy® and Pilot® Mounting Kit Bracket	D-10
5298	Envoy®, Digitrac®II and Pilot® Pivot-Mounting Kit	D-10
5304	Return Spring Set - Axle Set	M-9, M-12, M-13, M-14, M-18
5305	Return Spring Set - Axle Set	M-11, M-12, M-13, M-18
5306	Return Spring Set - Axle Set	M-10, M-18
5307	Return Spring Set - Axle Set	M-9, M-11, M-13, M-15, M-18
5320	Hardware Kit - Axle Set	M-10, M-18
5330	Hitch Hider Tube Cover, 2" Sq. Receivers w/Built-In 4-Flat E...	B-23
5350	Multi-Fit Motor Home Hitch, Fits Frames 24" to 46" Wide, Bla...	A-9
5351	Receiver Tube Cover, 1-1/4" Sq., Chrome, Metal	B-23
5352	Receiver Tube Cover, 2" Sq., Chrome, Metal	B-23
5353	Hold Down Kit - Axle Set	M-9, M-11, M-12, M-13, M-14, M-15, M-18
5362	Rubber Economy Receiver Tube Cover w/"D" Logo for 1-1/4" Sq...	B-23
5363	Receiver Tube Cover, 2" Sq., Black, Plastic (1202)	B-23
54000-026	4-Flat Trailer End Connector 11" Long, Coiled	C-17
54000-027	5-Flat Trailer End Connector 11" Long, Coiled	C-17
54001	Replacement Part, Taillight Lens Submersible 80 Series w/8 -...	K-19
54002	Replacement Part, Taillight Side Lens Submersible Under 80 S...	K-19
54003	Replacement Part, Taillight Side Lens Submersible Over 80 Se...	K-19
54003-017	Replacement Part, AG Harness, 4 Wire w/4-Way Square Connector	L-6
54003-018	Replacement Part, AG Harness, 4 Wire w/4-Way Square Connector	L-6
54003-020	Replacement Part, AG Harness, 4 Wire w/4-Way Weatherpack Con...	L-6
54003-040	Economy AG LED Light Kit, 7-Pin, Amber/Amber/Red, Tri-Mold w...	L-2, L-3
54003-041	Deluxe AG LED Transport Kit w/Brake Light Function, 7-Pin, A...	L-3
54003-137	Economy AG LED Light Kit, 7-Pin, w/ Pedestal Mount Amber/Amb...	L-4
54003-138	Deluxe AG LED Transport Kit w/Brake Light Function, 7-Pin, A...	5, L-4
54003-145	Ag Heavy-Duty Wishbone Harness, 1' Long for #108318	TBD
54003-146	Ag Extension Harness, 11'6" Long Left Side, for use with #10...	TBD
54003-147	Ag Extension Harness, 10'3" Long Right Side, for use with #1...	TBD
54004	Red Stop/Tail/Turn w/Black Flange w/Chrome Trim Snap Ring	K-10
54005	LED Oval Courtesy Light Clear w/Grommet w/3 Wire 90 Degree P...	K-22
54006	Red Stop/Tail/Turn Light w/Grommet w/3 Wire 90 Degree Pigtail	K-9
54006-009	7-Way Molded Trailer End w/6" Cable, Heavy Duty Cold Weather...	C-23
54006-010	7-Way Molded Trailer End w/8" Cable, Heavy Duty Cold Weather...	C-23
54006-015	7-Way Molded Trailer End w/10" Cable, Heavy Duty Cold Weathe...	C-23
54006-016	7-Way Molded Trailer End w/12" Cable, Heavy Duty Cold Weathe...	C-23
54006-043	Coiled 7-Way Molded Trailer Connector, 6'	C-23
54006-044	Coiled 7-Way Molded Trailer Connector, 8'	C-23
54006-045	Coiled 7-Way Molded Trailer Connector, 10'	C-23
54006-046	Coiled 7-Way Molded Trailer Connector, 12'	C-23
54006-049	Coiled 7-Way Molded Trailer Connector, 6'	C-23
54006-050	Coiled 7-Way Molded Trailer Connector, 8'	C-23
54006-051	Coiled 7-Way Molded Trailer Connector, 10'	C-23
54006-052	Coiled 7-Way Molded Trailer Connector, 12'	C-23
54006-057	7-Way Molded Trailer End w/6" Cable, Heavy Duty Cold Weather...	4, C-2, C-23
54006-058	7-Way Molded Trailer End w/8" Cable, Heavy Duty Cold Weather...	C-23
54006-059	7-Way Molded Trailer End w/10" Cable, Heavy Duty Cold Weathe...	C-23
5404	Adjusting Screw Kit	M-9, M-10, M-11, M-12, M-13, M-14, M-15, M-18
5407	Adjusting Screw Spring - Axle Set	M-18
54-18137	4, 5 and 6-Way Round Mounting Bracket (Includes Screws and N...	C-32
54200-003-100	Replacement Part, Gasket (Foam) for #92 Series Taillight (10...	K-14
54200-012	4" Round LED Tail Lamp with Mounting Flange	K-2, K-8
54200-013	4" Round LED Tail Lamp with Mounting Flange	K-2, K-8
54200-015	Narrow LED Tail Lamp	K-4
54200-016	Chrome Bezel for #54200-015	K-4
54200-018	LED Waterproof 4" Round Amber Turn Lamp	K-2, K-8
54-20012	7-Way US Car Mounting Bracket with Universal Mounting Bracke...	C-32
54-20045	5-Flat Mounting Bracket	C-32
54201-001	LED Waterproof Amber Side Marker Clearance Light w/Chrome Bezel	K-25
54201-002	LED Waterproof Red Side Marker Clearance Light w/Chrome Bezel	K-25
54201-003	Hi Intensity Micro LED Amber Side Marker Clearance Light w/G...	K-24
54201-004	Hi Intensity Micro LED Red Side Marker Clearance Light w/Gro...	K-24
54201-005	Hi Intensity Micro LED Clear Light w/Grommet	K-24
54201-006	Hi Intensity Micro LED Amber Side Marker Clearance Light w/G...	K-24
54201-007	Hi Intensity Micro LED Red Side Marker Clearance Light w/Gro...	K-24
54201-008	Hi Intensity Micro LED Clear Light w/Grommet	K-24
54201-010	Side Marker Clearance Light Incandescent #58 Amber w/Black Base	K-31

PART NO.	DESCRIPTION	PAGE NO.
54201-011	LED Fender Clearance Light Left Side	K-35
54201-013	LED Fender Clearance Light Right Side	K-35
54201-014	LED Fender Clearance Light Kit	K-35
54201-015	2.5" Round LED Red Clearance Light with Mounting Flange	K-28
54201-016	2.5" Round LED Red Clearance Light with Mounting Flange	K-2, K-28
54201-017	2.5" Round LED Amber Clearance Light with Mounting Flange	K-28
54201-018	2.5" Round LED Amber Clearance Light with Mounting Flange	K-2, K-28
54205-010	LED Light Strip Red - 36" w/54 Diodes Per Strip	K-36
54205-011	LED Light Strip Blue - 36" w/54 Diodes Per Strip	K-36
54205-012	LED Light Strip Amber - 36" w/54 Diodes Per Strip	K-36
54205-013	LED Light Strip Green - 36" w/54 Diodes Per Strip	K-36
54205-014	LED Light Strip Clear - 36" w/54 Diodes Per Strip	K-36
54205-015	LED Light Strip Red - 16' Per Reel (Bulk)	K-36
54205-016	LED Light Strip Blue - 16' Per Reel (Bulk)	K-36
54205-017	LED Light Strip Amber - 16' Per Reel (Bulk)	K-36
54205-018	LED Light Strip Green - 16' Per Reel (Bulk)	K-36
54205-019	LED Light Strip Clear - 16' Per Reel (Bulk)	K-36
54205-020	LED Multi-Functional Strobe Light w/11-3/4" Leads & Bracket ...	K-36
54205-021	LED Multi-Functional Strobe Light w/11-3/4" Leads & Bracket ...	K-36
54205-022	LED Strobe Light w/13' Coiled Cord & Magnetic Base - Amber	K-36
54205-023	LED Strobe Light w/13' Coiled Cord & Magnetic Base - Clear	K-36
54205-024	LED Strobe Light w/13' Coiled Cord & Magnetic Base - Purple	K-36
54206-001	License Plate Light, Mini LED	K-39
54209-001	Round Auxiliary LED Work Light for Hardwiring w/Mounting Stud	K-21, L-5
54209-002	Rectangular Auxiliary LED Work Light for Hardwiring w/Mounti...	K-21, L-5
54209-005	Replacement Part, Dual LH LED AG Light w/3-Wire Leads - Lens...	L-3
54209-006	Replacement Part, Dual LH LED AG Light w/3-Wire Plug (Lens: ...	L-3
54209-007	Replacement Part, Dual LH LED AG Light w/4 Wire Leads - Lens...	L-3
54209-008	Dual AG LED Light w/Amber/Red w/Brake Light Function	L-3
54209-009	Replacement Part, Single LED AG Light w/2 Wire Leads - Lens...	L-3
54209-010	Single AG LED Light w/Red/Black	L-3
54209-011	Replacement Part, Single LED AG Light w/2 Wire Leads - Lens...	L-3
54209-012	Single AG LED Light w/Amber/Amber	L-3
54209-013	Replacement Part, Single LED AG Light w/3 Wire Leads - Lens...	L-3
54209-014	Replacement Part, Single LED AG Light w/3-Way Plug - Lens: R...	L-3
54209-015	Replacement Part, Single LED AG Light w/3 Wire Leads - Lens...	L-3
54209-016	Replacement Part, Single LED AG Light w/3-Way Plug - Lens" R...	L-3
54209-017	Round Auxiliary LED Work Light w/19' Coiled Cord & Magnetic ...	K-21, L-5
54209-018	Rectangular Auxiliary LED Work Light w/19' Coiled Cord & Mag...	K-21, L-5
54209-019	Replacement Part, Dual RH LED AG Light w/3 Wire Leads - Lens...	L-3
54209-020	Dual AG LED Light w/Red/Amber	L-3
54209-021	Replacement Part, Dual RH LED AG Light w/4 Wire Leads-Lens: ...	L-3
54209-022	Dual AG LED Light w/Red/Amber w/Brake Light Function	L-3
54209-025	Rectangular Auxiliary LED Work Light w/2-Flat Plug & Mountin...	K-21, L-5
54209-031	Pedestal Mount AG LED Light w/Amber	L-4
54209-032	Pedestal Mount Single AG LED Light w/Red	L-4
54209-037	Pedestal Mount AG LED Light w/Amber	L-4
54209-048	Pedestal Mount Single AG LED Light w/Red	L-4
5443	Front Mounted Receiver Accessory, License Plate Holder	A-12
54504-001	Protective Tail Light Bracket	K-7, K-8, K-10, K-15
54504-003	Protective Tail Light Bracket	K-7, K-8, K-10, K-15
54-57-007	7-Way Metal Connector, Trailer End	C-21
54-57-503	7-Way Metal Connector, Car End	C-21
54-60-101	6-Way Metal Connector, Car End - USA	C-20
54-60-103	6-Way Metal Connector, Trailer End - USA	C-20
54-6562	7-Way Blade Tester and Trailer Emulator w/LED Display	C-37
54-67-525	7-Way Molded Trailer End Kit w/ 1' Cable (Includes Hardware)	C-24
54700-010	Screw Kit for Aluminum Beds	C-25
54-77-001	7-Way Plastic Connector, Car End	C-21
54-77-003	7-Way Plastic Connector, Trailer End	C-21
54-77-071	7-Way Mounting Bracket	C-32
54-77-075	7-Way / 5-Flat Mounting Bracket	C-32
54801-001	Brake Assembly, Right Hand, 10" x 2-1/4"	M-7
54801-002	Brake Assembly, Left Hand, 10" x 2-1/4"	M-7
54801-003	Brake Assembly, Right Hand, 12" x 2"	M-7
54801-004	Brake Assembly, Left Hand, 12" x 2"	M-7
54801-005	Brake Assembly, Right Hand, 10" x 2-1/4", Self-Adjusting	M-7
54801-006	Brake Assembly, Left Hand, 10" x 2-1/4", Self-Adjusting	M-7
54801-007	Brake Assembly, Right Hand, 12" x 2", Self-Adjusting	M-7
54801-008	Brake Assembly, Left Hand, 12" x 2", Self-Adjusting	M-7
54801-023	Brake Assembly, Right Hand, 10" x 2-1/4"	M-7
54801-024	Brake Assembly, Left Hand, 10" x 2-1/4"	M-7
54801-025	Brake Assembly, Right Hand, 12" x 2"	M-7
54801-026	Brake Assembly, Left Hand, 12" x 2"	M-7
54801-126L	Brake Assembly, Left Hand, 12" x 2"	M-7
54801-126R	Brake Assembly, Right Hand, 12" x 2"	M-7

PRODUCT NUMERICAL

PART NO.	DESCRIPTION	PAGE NO.
54801-156L	Brake Assembly, Left Hand, 10" x 2-1/4"	M-7
54801-156R	Brake Assembly, Right Hand, 10" x 2-1/4"	M-7
5481	7/16" Wire Forms for Fishwiring Bolts in Frames (20 pack)	A-11
5482	1/2" Wire Forms for Fishwiring Bolts in Frames (20 pack)	A-11
54-85-002	Replacement Part, 48" Cable for Breakaway Switch #54-85-007	M-6
54-85-007	Breakaway Switch w/48" Cable and Pin Assembly	M-6
54970	Wt. Dist. Shank, 15,000 lbs. (GTW), 1,500 lbs. (TW), 12-1/4"...	E-15, O-2, O-3, O-4, O-6, O-7
54977	Titan®, Wt. Dist. Shank, Rating 1,700 lbs. (TW), 2-1/2" Dia...	E-11, O-3
54980	Replacement Part, Adjustable Trunnion Weight-Distributing Bo...	E-14
54-98-002	Battery Isolator - 3 Terminal	C-36
54-98-003	6 & 7-Way Plug Holder	C-34
54-98-004	Battery Isolator - 4 Terminal	C-36
54-98-050	7-Way Blade to 4-Flat Adapter	C-28
54-98-051	7-Way Blade to 6-Way Round Pin (Auxiliary in Center) Adapter	C-28
54-98-052	7-Way Round Pin to 4-Flat Adapter	C-28
54994	Replacement Part, Adjustable Trunnion Weight-Distributing Bo...	E-14
54998	Wt. Dist. Shank, 16,000 lbs. (GTW), 1,600 lbs. (TW), 12-1/4"...	E-2, E-15
55010	5/8" Hitch Pin for 2" Sq. Receivers	B-18, O-2, O-3, O-4, O-6, O-7
55010-050	5/8" Hitch Pin for 2" Sq. Receivers (50 pack)	B-18
5502	Bearing Sets (Cup & Cone)	M-8, M-9, M-10, M-11, M-12, M-13, M-14, M-18
5503	Bearing Sets (Cup & Cone)	M-8, M-9, M-10, M-11, M-12, M-13, M-14, M-18
55030	Replacement Part, Wt. Dist. Part, Reducer Bushing (1-1/4" to...	O-6
5504	Activator® IV Electronic Brake Control, for 1 to 4 Axle Trail...	D-8
5505	Bearing Sets (Cup & Cone)	M-8, M-9, M-11, M-13, M-14, M-18
55055	Replacement Part, Knurl Bolt (1/2" - 13 x 1-1/2") Grade 5 fo...	O-18
5506	Bearing Sets (Cup & Cone)	M-8, M-11, M-18
5507	Bearing Sets (Cup & Cone)	M-8, M-10, M-11, M-12, M-13, M-14, M-15, M-18
5508	Bearing Sets (Cup & Cone)	M-8, M-9, M-12, M-18
5509	Bearing Sets (Cup & Cone)	M-8, M-9, M-12, M-18
55180	Replacement Part, Safety Pin for Snap-up Bracket #21501	O-3, O-4, O-6, O-7
5535	I-Command Electronic Brake Control, for 1 to 4 Axle Trailers...	4, D-2, D-7, P-9
55392	1/2" Wire Forms for Fishwiring Bolts in Frames (1 piece)	A-11
55393	3/8" Wire Forms for Fishwiring Bolts in Frames (1 piece)	A-11
55478	Replacement Part, Klik Pin for 16K Fifth Wheel	O-14
55515	Clip used w/#06237, #55010, #74149 Hitch Pins	B-18, O-2, O-3, O-4, O-6, O-7, O-8
55515-050	Clip used w/#06237, #55010, #74149 Hitch Pins (50 pack)	B-18
55630	Replacement Part, Weight Distribution Chain Kit (Includes: [...	O-3, O-4
5592	Safety Chain, Class II, 72" Length	M-24
5602	Grease Seal	M-17
5603	Grease Seal	M-10, M-17
5604	Grease Seal	M-9, M-11, M-12, M-13, M-14, M-17
5605	Grease Seal	M-9, M-13, M-14, M-15, M-17
5606	Grease Seal	M-11, M-12, M-17
5607	Grease Seal	M-10, M-17
5608	Grease Seal	M-11, M-12, M-17
5651	Grease Cap	M-9, M-10, M-11, M-12, M-13, M-14, M-17
5652	Grease Cap	M-9, M-11, M-12, M-13, M-14, M-15, M-17

PART NO.	DESCRIPTION	PAGE NO.
5691	Receiver Fabrication Part, 12" Combo Bar w/Forged Collar, 2"...	A-10
5692	Receiver Fabrication Part, 18" Combo Bar w/Forged Collar, 2"...	A-10
5707	Brake Assembly - Dexter 10" x 2-1/4" L/H	M-7, M-11, M-17
5708	Brake Assembly - Dexter 10" x 2-1/4" R/H	M-7, M-11, M-17
5711	Brake Assembly - Dexter 12" x 2" L/H	M-7, M-11, M-17
5712	Brake Assembly - Dexter 12" x 2" R/H	M-7, M-11, M-17
5713-HA	Brake Assembly - Hayes 12" x 2" L/H - Replace in Pairs	M-7, M-13, M-17
5714-HA	Brake Assembly - Hayes 12" x 2" R/H - Replace in Pairs	M-7, M-13, M-17
5720	Brake Assembly Mounting Bolt - 3/8"	M-8, M-17
5721	Brake Assembly Mounting Bolt - 7/16"	M-8, M-17
5761	Clevis Ball Mount, 2" Sq. Hollow Shank, 9-3/4" Length, Ratin...	B-17
5762	Clevis Ball Mount, 2" Sq. Hollow Shank, 9-3/4" Length, Ratin...	B-17
5763	Pin for Clevis Mount, 3/4" Diameter	B-17
5764	Pin for Clevis Mount, 1" Diameter	B-17
5774	Spindle Nut Kit	M-8
5775	Spindle Nut Kit	M-8
5780	Trailer Tongue Weight Scale, 2,000 lbs. Capacity	E-16
5780TEK	Wheel Nut	M-8
5787	Wheel Bolt	M-8
58024	Replacement Part, High-Performance Trunnion Bar Wt. Dist. Ad...	O-3
58032	Replacement Part, U-Bolt Package for Attaching Chain to Spri...	O-3, O-4
58033	Replacement Part, 2 - Square Head Set Screws for Snap-up Bra...	O-3, O-9
580400	5/8" Chrome Bent Pin Lock	B-20
580401	5/8" Chrome Dogbone Lock	B-20
580402	5/8" SS Dogbone Lock	B-20
580403	Chrome Coupler Lock	B-20
580404	5/8" Chrome Dogbone Lock w/ Chrome Coupler Lock	B-20
580405	Stainless Steel Dogbone Lock w/Sleeve for 1-1/4" & 2" Square...	B-20
580406	Stainless Steel Combo Lock Set, 5/8" Dogbone Lock w/Sleeve f...	B-20
580407	Easy Access Lock w/Sleeve for 1-1/4" & 2" Square Receivers	B-20
580408	STAINLESS STEEL COUPLER LOCK	B-20
580409	Easy Access Long Coupler Lock	B-20
580410	Easy Access Adjustable Coupler Lock	B-20
580412	Receiver Lock, Dogbone Style, 5/8" for 2-1/2" Sq. Class V Re...	B-21
58053	Replacement Part, 4 Pins & Clips for DT #6000, DT #6001, DT ...	O-14, O-17
58054	Replacement Part, Clip Ring Kit for DT #6000, DT #6001, DT #...	O-14, O-17
58055	Replacement Part, Handle Kit for DT #6000, DT #6001, DT #602...	O-14, O-17
58056	Replacement Part, Jaw Kit for DT #6000, DT #6001, DT #6021, ...	O-14, O-17
58058	Fifth Wheel Mounting Rails Only (10 - Bolt Design)	F-16, F-19, O-18
58060	Replacement Part, Ball Assembly for DT #3400, RS #26660 & PS...	E-14, O-8
58062	Replacement Part, Sway Control Adapter, Ball and Plate Assem...	E-14, O-8
58070	Receiver Tube Cover, 1-1/4" Sq., Black Plastic, (24 pack)	B-23
58079	The Goose® Gooseneck Hitch (Requires Rails & Installation Ki...	F-17, G-6
58089	Replacement Part, Fifth Bumper Installation Kit for DT #6001...	O-14
58093	Fifth Wheel Lock Links (4 pack)	F-18
58094	Replacement Part, Rubber Grip for Fifth Wheel Handles	O-14, O-17
58097	Replacement Part, High-Performance 1-3/8" Trunnion & Pin	O-2, O-3
58098	Replacement Part, High-Performance 1-1/8" Trunnion & Pin	O-2, O-3
58099	Replacement Part, 22K Head Assembly Only	F-11, O-17
58102	Titan®, Ball Mount Reducer Bushing (2-1/2" to 2")	B-14
58109	Reducer Bushing 1" to 3/4"	B-14
58112	Replacement Part, Adjustable Ball Mount w/Hardware for Heavy...	E-10, O-4
58114	Replacement Part, Heavy-Duty Round Bar/800 lbs. Spring Bar (...	E-10, O-4
58115	Replacement Part, Heavy-Duty Round Bar/1200 lbs. Spring Bar ...	E-10, O-4
58117	Hitch Ball Lube	B-4
58133	Replacement Part, High-Performance Trunnion Bar Wt. Dist. Bo...	O-2, O-3
58146	Replacement Part, 16K Fifth Wheel Head for #58147	F-12, O-14
58147	Replacement Part, 16K Cross Member for #58146	F-12, O-14
58162	Replacement Part, Snap Up Bracket Handle	E-16, O-3, O-4, O-6
58164	Replacement Part, Fifth Wheel Rail Hardware Kit (Except Moun...	O-18
58167	Replacement Part, Titan® Trunnion Weight-Distributing Bolt-T...	E-9, E-11, O-2, O-3
58184	Reducer Bushing, 1-1/4" to 1"	B-14, O-2, O-3, O-4, O-7
58192	Replacement Part, Hanger Brackets (Qty. 2) for Dual Cam HP D...	O-9
58207	Replacement Part, Heavy-Duty Round & High-Performance Trunni...	E-9, E-10
58215	Replacement Part, 18K & 24K Signature Series & 18K Select Pl...	O-10, O-11, O-12, O-16
58216	Replacement Part, 16K, 18K & 24K Signature Series Fifth Whee...	O-10, O-11, O-12, O-16
58225	Replacement Part, 18K Signature Series Fifth Wheel Center Se...	O-10
58229	Replacement Part, 16K, 18K & 24K Signature Series Fifth Whee...	O-10, O-11, O-12, O-16
58230	Replacement Part, 16K, 18K & 24K Signature Series Fifth Whee...	O-10, O-11, O-12, O-16

PRODUCT NUMERICAL

PART NO.	DESCRIPTION	PAGE NO.
58240	Replacement Part, 16K, 18K & 24K Signature Series Fifth Whee...	0-10, 0-11, 0-12, 0-16
582551	Replacement Part, 16K, 18K & 24K Signature Series Fifth Whee...	0-10, 0-11
58276	Replacement Part, 16K, 18K & 24K Signature Series Fifth Whee...	0-10, 0-11, 0-12
58293	Replacement Part, 18K Select Plus Fifth Wheel Center Section	0-16
58296	Replacement Part, 18K Select Plus Fifth Wheel Center Section...	0-16
58305	Wt. Dist. Accessory, Chain Hanger, Bolt On	E-16
58306	Wt. Dist. Accessory, Chain Hanger, Clamp On	E-16
58312	Replacement Part, Gooseneck Head U-Bolt Kit for #9460, #9461...	G-10
58314	Replacement Part, Mounting Brackets for Fifth Wheel Rails	F-19, 0-18
58333	Replacement Part, Pro Series RB2 & Trunnion Weight Distribut...	0-6, 0-7
58336	Replacement Part, Pro Series RB2 Round Bar/600 lbs. Spring B...	0-6
58337	Replacement Part, Pro Series RB2 Round Bar/800 lbs. Spring B...	0-6
58338	Replacement Part, Pro Series RB2 Round Bar/1,200 lbs. Spring...	0-6
58339	Replacement Part, Pro Series RB2 & Trunnion Weight Distribut...	0-6, 0-7
58344	Replacement Part, Pro Series Trunnion Bar/600 lbs. Spring Ba...	0-7
58345	Replacement Part, Pro Series Trunnion Bar/800 lbs. Spring Ba...	0-7
58346	Replacement Part, Pro Series Trunnion Bar/1200 lbs. Spring B...	0-7
58349	Replacement Part, Reese SC™ Pad Hanger Cover	0-2
58350	Replacement Part, Reese SC™ Pad Hanger	0-2
58351	Replacement Part, Reese SC™ Lift Handle	0-2
58352	Replacement Part, Reese SC™ Welded Frame Bracket Kit (1 - Side)	0-2
58356	Replacement Part, Reese SC™ 600 lbs. Spring Bar	E-7,0-2
58357	Replacement Part, Reese SC™ 800 lbs. Spring Bar	E-7,0-2
58358	Replacement Part, Reese SC™ 1200 lbs. Spring Bar	E-7,0-2
58359	Replacement Part, Reese SC™ 1500 lbs. Spring Bar	E-7,0-2
58362	Replacement Part, Pro Series RB2 & Trunnion Snap-up Bracket ...	0-6, 0-7
58364	Replacement Part, Pro Series RB2 & Trunnion Spring Bar Mount...	0-6, 0-7
58369	Replacement Part, Ultra Frame 1500 lbs. Spring Bar	E-9, 0-3
58374	Ultra Frame Accessory, Crosstube End Caps for Weld Together ...	A-7
58381	3-1/2" Hole Saw For Hide-A-Goose	A-11, G-10
58385	Replacement Part, 20K & 22K Fifth Wheel Base Vertical Adjust...	F-11
58388	Replacement Part, Super Titan®, 3/4" Hitch Pin and Clip for ...	B-14, B-18
58389	Replacement Part, Magnetic Cover for Hide-A-Goose™ Gooseneck	G-10
58392	Replacement Part, Titan® & Ultra Frame Snap-up Bracket w/Set...	E-9, E-10, E-11, E-16, 0-3, 0-4
58393	Pole Tongue Adapter and Fastener Kit	E-16
58419	Replacement Part, Service Kit Adapter Foot for Signature Ser...	F-5, G-6, 0-10, 0-11, 0-12
58431	Titan®, Ball Mount Reducer Bushing w/Collar (2-1/2" to 2")	B-14
58435	Replacement Part, Cam Arm Assembly (Qty. 2) for Dual Cam HP ...	0-9
58437	Replacement Part, Thread Forming Screw 1/2"-13 (Qty.8) for D...	0-9
58438	Replacement Part, Stabilizer Strips for Hide-A-Goose #9480 &...	G-8
58439	Replacement Part, Pro Series Complete RB & RB3, 550 lbs. Spr...	E-12, E-13
58440	Replacement Part, Pro Series Complete RB & RB3, 750 lbs. Spr...	E-12, E-13
58441	Replacement Part, Pro Series Complete RB & RB3, 1000 lbs. Sp...	E-12, E-13
58442	Replacement Part, Pro Series Complete RB & RB3, Weight Distr...	E-12, E-13
58444	Replacement Part, Pro Series Complete RB & RB3, Weight Distr...	E-12, E-13
58445	Replacement Part, Titan® 16K Fifth Wheel Head Support	0-13
58446	Replacement Part, Titan® 16K Fifth Wheel Head	0-13
58447	Replacement Part, Titan® 16K Pivot Beam & Isolators	0-13
58449	Replacement Part, Titan® 16K & 20K Legs (Qty. 2)	0-13, 0-15
58451	Replacement Part, Logo Plate for Titan® 16K	0-13
58452	Replacement Part, Titan® 20K Head Support	0-15
58453	Replacement Part, Titan® 20K Fifth Wheel Head	0-15
58454	Replacement Part, Titan® 20K Pivot Beam & Isolators	0-15
58455	Replacement Part, Titan® 20K Pivot Beam Isolators w/Mounting...	0-15
58456	Replacement Part, Titan® 20K Pivot Pin w/Logo Plate & Hardware	0-15
58457	Replacement Part, Titan® 20K Fifth Wheel Lube Plate w/Mounti...	0-15
58458	Replacement Part, Trim Rings (Qty. 4) for GM & Dodge Elite™ ...	F-5
58459	Replacement Part, Thread Forming Screw 1/2"-13 (Qty.2) for S...	0-3
58467	Replacement Part, Hole Style Pins (Qty. 4) & Clips (Qty. 4) ...	F-8, F-19, 0-13
58468	Replacement Part, Safety Chain Attachment (Qty. 2) for Elite...	G-6
58471	Replacement Part, Pro Series 20K Head Assembly	F-15
58472	Replacement Part, Pro Series 20K Crossmember	F-15
58473	Replacement Part, Pro Series 16K & 20K Handle, Grip & Cotter...	F-15
58474	Replacement Part, Pro Series 20K Pivot Pin, Nut & Cotter Pin	F-15
58475	Replacement Part, Pro Series 20K Fifth Wheel Hardware Kit	F-15
58476	Replacement Part, Pro Series 16K Head Assembly w/Dual Jaw Sy...	F-15
58484	Replacement Part, Pivot Pin & Klik Pin for 16K Fifth Wheels	F-15, 0-14
58489	Replacement Part, Titan® 16K King Pin Indicator w/Mounting H...	0-13
58490	Replacement Part, Titan® 16K Mounting Hardware (Includes: 2...	0-13
58491	Replacement Part, Titan® 16K & 20K Linkage & Linkage Bushing	0-13, 0-15
58492	Replacement Part, Titan® 16K & 20K Handle Bushing w/Mounting...	0-13, 0-15
58493	Replacement Part, Titan® Round Tube Slider Handle, Grip, Rol...	F-8
58497	Replacement Part, Friction Pad Kit for Light Weight Distribu...	0-5

PART NO.	DESCRIPTION	PAGE NO.
58498	Replacement Part, Spring Bar Retention Bracket Kit for Light...	0-5
58499	Replacement Part, Head Adjustment Pin & Washers Kit for Ligh...	0-5
58500	Replacement Part, Spring Bar Kit for Light Weight Distributi...	0-5
58502	Replacement Part, Titan® 20K King Pin Indicator w/Mounting H...	0-15
58503	Fifth Wheel Mounting Rails Accessory, Corrugation Spacer Kit...	F-19
58504	Replacement Part, Installation Hardware for #30035/#30153/#5...	F-19
58507	Dual Cam HP Accessory, Rivet Nuts (Qty. 4)	E-14
58511	Replacement Part, Titan® 20K Mounting Hardware (Includes: (4...	0-15
58512	Replacement Part, Reese SC Friction Pads w/Screws	0-2
58513	Replacement Part, Distributing Bolt-Together Head Kit for #6...	0-5
58514	Replacement Part, Shim Kit for Elite Series Center Sections	0-10, 0-11, 0-12
58515	Replacement Part, Titan® 16K Pivot Beam Isolators w/Mounting...	0-13
58516	Replacement Part, Titan® 20K Pivot Beam Isolators w/Mounting...	0-15
58517	Replacement Part, Service Kit, Dual Cam Hanger Brackets	E-7
58518	Service Kit, Reese SC™ 800 lbs. Bracket for Bottom Mounted C...	0-2, E-7
58519	Service Kit, Reese SC™ 1,200 lbs. Bracket for Bottom Mounted...	0-2, E-7
58521	Replacement Part, 16K Head Assembly Hardware (Contains: (1) ...	F-14, 0-14, F-12
58524	Replacement Part, Cover for Hide-A-Goose™ Gooseneck (Only Wo...	G-10
58530	Replacement Part, Rubber Bolt Cap for #75662, 87530 & 44603	A-11
58541	Replacement Part, 26.5K Elite Series Fifth Wheel Center Secti...	F-3, 0-12
58542	Replacement Part, 26.5K Elite Series Fifth Wheel Center Sect...	F-3, 0-12
58543	Replacement Part, 26.5K Elite Series Fifth Wheel Base Arches	F-3, 0-12
59000	ROLA®, MOVE® Rigid Base Small Interior Organizer (25" x 15" ...	I-14
59001	ROLA®, MOVE® Rigid Base Large Interior Organizer (38" x 15" ...	I-14
5901TEK	P3® T-Slot Bracket	D-10
5904	P3® T-Slot Metal Bracket	D-10
5906	Replacement Part, P3® T-Slot Mounting Kit	D-10
59100	ROLA®, Platypus® Expandable Roof Top Bag (10 to 15 cubic ft.)	I-13
59102	ROLA®, Wallaroo® Expandable Cargo Carrier Bag (9-1/2 to 11-1...	I-13
59108	ROLA®, Adventure System (Includes Tray w/Lights, Pod & 1-1/4" ...	I-9
59109	ROLA®, Adventure System w/Swing Away (Includes Tray w/Lights...	I-2, I-9
59110	ROLA®, Adventure System w/Tilt (Includes Tray w/Lights, Pod ...	I-9
59117	ROLA®, Adventure System License Plate Light Kit for the Carg...	I-9
59119	ROLA®, TuffBak™ Cargo Carrier Bag, Rainproof (20 cubic ft.)	I-13
59200	ROLA®, Flat Strap Cargo Net - 36" x 48"	I-12
59204	ROLA®, Lashing Strap - 1" x 10"	I-15, I-33
59300	Replacement Part, Boat Tie Down Kit for #59912, #59913	I-15
59301	Replacement Part, Bottom Mounting Bracket for #59912	I-15
59302	Replacement Part, Pivot Knob Assembly for #59913	I-15
59303	Replacement Part, Bottom Mounting Bracket for #59913	TBD
59309	Replacement Part, 9' Strap Kit for #59912, #59913	I-15
59313	Replacement Part, 13' Strap Kit for #59912, #59913	I-15
59400	ROLA®, TX-102 Bike Carrier, 2 Bike, 1-1/4" Sq. or 2" Sq. Rec...	I-3
59401	ROLA®, TX-104 Bike Carrier, 4 Bike, 2" Sq. Receiver Mount, F...	I-3
59403	ROLA®, TX-103 Bike Carrier, 3 Bike, Triple X w/Tilt Function...	I-3
59404	ROLA®, Canyon™ Bike Carrier, 1 Bike, Roof Top Rack w/Fork St...	I-6
59405	Replacement Part, TX Strap (Qty. 2) for Bike Racks #59400, #...	I-3
59406	Replacement Part, TX Cradle (Qty. 1) for Bike Racks #59400, ...	I-3
59407	Replacement Part, TX Anti-Sway Cradle & Strap (Qty. 1) for B...	I-3
59500	ROLA®, Flathead™ 2" Polypropylene Cargo Carrier, 22" x 56" P...	I-9
59502	ROLA®, Vortex™ Steel Cargo Carrier for 2" Sq. Receivers w/5-...	I-7
59504	ROLA®, Vortex™ 2 - Piece Roof Top Cargo Carrier (48" x 37-1/...	I-11
59505	ROLA®, Vortex™ Roof Top Cargo Carrier Extension (18-3/4")	I-11
59506	Replacement Part, ROLA®, Vortex™ Roof Top Cargo Carrier #595...	I-11
59507	ROLA®, Vortex™ Steel Cargo Carrier for 1-1/4" Sq. Receivers ...	I-7
59508	ROLA®, NV2™ Bike Carrier, 2 Bike, 1-1/4" Sq. or 2" Sq. Recel...	I-3
59510	Replacement Part, Latch Kit for #59109, #59110	I-9
59516	LED Light Kit For Railed Cargo Carrier Part #63152, #63153, ...	I-7, I-12
59520	Replacement Part, ROLA®, 2" Steel Cargo Carrier #59502, Hard...	I-7
59530	ROLA®, Packer™ Cargo Carrier w/2-1/2" Side Rails, 20" x 60" ...	I-8
59531	Cargo Carrier Reflector Kit (Qty. 2) for #59550, #59502, #59...	I-7, I-8
59550	ROLA®, Dart™ Folding Cargo Carrier for 2" Sq. Receivers w/5-...	I-7
59560	Replacement Part, ROLA® Expandable Cargo Bag #59102, Strap K...	I-13
59621	Haul-Your-Might™ Universal 1 Bar Van Rack	I-16
59622	Haul-Your-Might™ V2 Universal 2 Bar Van Rack	I-16
59623	Haul-Your-Might™ V3 Universal 3 Bar Van Rack	I-16
59650	Complete Direct Mounting Kit, (4) Mounting Adapters for Shee...	I-20
59651	Complete Direct Mounting Kit, (4) Mounting Adapters for Shee...	I-20
59652	Complete Direct Mounting Kit, (4) Mounting Adapters for Fibe...	I-20
59653	Complete Direct Mounting Kit, (4) Mounting Adapters for Fibe...	I-20
59654	Complete Direct Mounting Kit, (4) Mounting Adapters for Fibe...	I-20
59655	Complete Track Rail System, 42" Length (1070mm) for Sheet Me...	I-20
59656	Complete Track Rail System, 42" Length (1070mm) for Sheet Me...	I-20
59657	Complete Track Rail System, 54" Length (1370mm) for Sheet Me...	I-20
59658	Complete Track Rail System, 54" Length (1370mm) for Sheet Me...	I-20
59659	Complete Track Rail System, 60" Length (1520mm) for Fibergla...	I-20

PRODUCT NUMERICAL

PART NO.	DESCRIPTION	PAGE NO.
59701	Replacement Part, Bolts (4) M6 x 30MM	I-29
59702	Replacement Part, Bolts (4) M6 x 50MM	I-29
59703	Replacement Part, Quarter Turn Plugs (4)	I-29
59710	Replacement Part, Cage Nuts M6-1 (4)	I-29
5973	Replacement Part, 2-5/16" Ball	G-10
59745	Replacement Part, REX Series Cross Bar End Cap (Qty.1) Servi...	I-29
59746	Replacement Part, APE-RE Series Cross Bar Undercover (Qty.2)...	I-29
59747	Replacement Part, RBU Series Cross Bar Undercover (Qty.2) Se...	I-29
59748	Replacement Part, RBU Series Cross Bar End Support (Qty.1) S...	I-29
59749	Replacement Part, RBU Series Cross Bar Buffer Strips (Qty.2)...	I-29
59750	Replacement Part, REX Series Cross Bar T-Handle 5mm Hex Driv...	I-29
59772	Roof Rack, Removable Anchor Point Extended APE Series - Trac...	I-29
59773	Roof Rack, Removable Anchor Point Extended APE Series - Trac...	I-29
59774	Roof Rack, Removable Anchor Point Extended APE Series - Trac...	I-29
59785	Replacement Part, Bolts (4) M6 x 55MM	I-29
59792	Truck Bed Rack Accessory, Tool Rack	I-18
59793	Truck Bed Rack Accessory, Trimmer Rack Kit	I-18
59794	Truck Bed Rack Accessory, Load Stop Kit	I-18
59795	Truck Bed Rack Accessory, Tie Down Kit	I-18
59796	Truck Bed Rack Accessory, Eye Bolt Kit	I-18
59797	Truck Bed Rack Accessory, Conduit Kit (Requires 6" Diameter ...	I-17
59798	Truck Bed Rack Accessory, Top Rail Kit	I-17
5983	Replacement Part, Magnetic Cover	G-10
59846	Replacement Part, Cross Bar Buffer Strips (Qty.2) Service Ki...	I-29
59847	Replacement Part, L-Handle T-27 Torx Driver (Qty.2) Service ...	I-29
59850	Replacement Part, Truck Bed Rack, M8 T-Bolt	I-16
59886	Replacement Part, RBXL Series Support Cover Kit (Includes: (...	I-29
59887	Replacement Part, GTX Series Support Cover Kit (Includes: (1...	I-29
59903	Replacement Part, APE Series Crossbar Hardware (Includes: (1...	I-8
59904	ROLA®, Dart™ 1 - Bike Mounting Adapter Kit for #59502, #5950...	I-6, I-7
59905	Replacement Part, Locking Knob for Truck Rack 59799	I-16
59913	Hull-Hauler™ Universal, Multi-Pivot Water Craft Carrier	I-15
59914	Hull-Hugger™ Folding Kayak Rack, Wall Mount Storage	I-15
59915	Replacement Part, ROLA®, M12 Lock Pin for #59530, #59550, #5...	I-6, I-8, I-12
59917	Replacement Part, ROLA®, 15MM Wrench for 59530	I-8
5AB-E1621-16K	Fifth Airborne Extended 12" Wide Air Ride, 1-Piece Design	H-2, H-7
5AB-E1621-610	Fifth Airborne Extended 12" Wide Air Ride	H-7
5AB-E510-710	Fifth Airborne Extended 12-1/2" Wide Air Ride	H-7
5AB-E7920	Fifth Airborne for Lealand 7920 Trailer Frames	H-7
5AB-S500-700	Fifth Airborne Standard 12-1/2" Wide Air Ride Pin Box	H-7
5AS16K	Fifth Airborne Sidewinder Complete Arm Assembly	H-4
60037	Class I & II 1-1/4" Sq. Receiver Cover w/Hidden Hitch Logo, ...	B-23
60037-024	Class I & II 1-1/4" Sq. Receiver Cover w/Hidden Hitch Logo, ...	B-23
6004	Shoe and Lining Kit - Alko 10" x 2-1/4" - Wheel Set	M-9, M-13, M-17
6005	Shoe and Lining Kit - Alko 12" x 2" - Wheel Set	M-9, M-17
6011	Fifth Wheel 10" Round Lube Plate, 3/16" Thick	F-18
6020	Replacement Part, Fifth Wheel Head Mounting Pin & Clip (1 set)	O-17
60-50-001	Mounting Bracket (MB 1200)	K-40
61009	1200 lbs. Heavy Duty Round Bar WD Hitch w/54970 Shank	E-10, O-4
6106	Magnet Kit - Alko 10" x 2-1/4"	M-9, M-16, M-17
6109	Magnet Kit - Alko 12" x 2", 6 & 7K	M-9, M-16, M-17
61300	Sidewinder Turret w/Hardware	H-4, H-5, H-6
61301	Spacer Kit for Sidewinder Turret When Replacing 12-1/2" Pin Box	G-3, H-3, H-4, H-5
61302	Sidewinder Turret w/Hardware	H-4, H-5, H-6
61410	Sidewinder Combo, 16K Arm w/King Pin #SW16K, Turret w/Hardw...	H-5
61411	Sidewinder Combo, 19K Arm w/King Pin #SW19K, Turret w/Hardw...	H-6
61412	Elite™ Series Airborne Sidewinder Combo, 16K Arm w/King Pin ...	H-2, H-4
61420	Sidewinder Combo, 16K Arm w/King Pin #SW16K, Turret w/Hardw...	H-5
61421	Sidewinder Combo, 19K Arm w/King Pin #SW19K, Turret w/Hardw...	H-6
61422	Elite™ Series Airborne Sidewinder Combo, 16K Arm w/King Pin ...	H-4
6145	Bike Carrier Y-Frame Adapter	I-6
61450	Sidewinder Combo, 16K Arm w/King Pin #SW16K & Turret w/Hardw...	H-5
61452	Elite™ Series Airborne Sidewinder Combo, 16K Arm w/King Pin ...	H-4
61500	Replacement Part, Left Hand 10K Revolution Wing	H-8
61501	Replacement Part, Right Hand 10K Revolution Wing	H-8
61510	10K Revolution Combo	5, H-2, H-8
61516	16k Revolution, No Wings	H-8
62	6-Way Metal Connector, Car End	C-20
6201	Clevis Ball Mount, 2" Sq. Solid Shank, 8-7/8" Length, Rating...	B-17
63	6-Way Metal Connector, Trailer End	C-20
6300	Remov-A-Ball® Gooseneck Hitch w/2-5/16" Ball, Rating 30,000 ...	G-2, G-8
63010	Pintle Hook w/1-7/8" Ball (Inc. Grade 8 Hardware) Hook Ratin...	B-16
63011	Pintle Hook w/2" Ball (Inc. Grade 8 Hardware) Hook Rating 16...	B-16
63012	Pintle Hook w/2-5/16" Ball (Inc. Grade 8 Hardware) Hook Rati...	B-16
63013	5 Ton Regular Pintle Hook (Inc. Grade 8 Hardware) Rating 10...	B-16
63014	10 Ton Regular Pintle Hook (Inc. Grade 8 Hardware) Rating 20...	B-16
63015	15 Ton Regular Pintle Hook (Inc. Grade 8 Hardware) Rating 30...	B-16

PART NO.	DESCRIPTION	PAGE NO.
63016	30 Ton Regular Pintle Hook (Hardware Included) Rating 60,000...	B-16
63017	Replacement Part, Pintle Hook Replacement Ball, 1-7/8" x 1-1/4" ...	B-17
63018	Replacement Part, Pintle Hook Replacement Ball, 2" x 1-1/4" ...	B-17
63019	Replacement Part, Pintle Hook Replacement Ball, 2-5/16" x 1-1/4" ...	B-17
63020	Replacement Part, Pin & Chain Assy. for Pintle Hooks, 1/4" D...	B-17
63022	Lunette Ring, 2-1/2" Diameter, w/1-1/2" Shank 15,000 lbs. Ca...	B-16
63023	4 Bolt Flange Lunette Ring, 2-1/2" Diameter, 42,000 lbs. Cap...	B-16
63024	Forged D-Ring w/Mounting Bracket, 1/2", 12,000 lbs., Yellow ...	M-25
63025	Forged D-Ring w/Weld On Mounting Bracket, 5/8" Dia. x 3/8" T...	M-25
63026	Forged D-Ring w/Weld On Mounting Bracket, 3/4" Dia. x 3/8" T...	M-25
63027	Forged D-Ring w/Weld On Mounting Bracket, 1" Dia. x 3/8" Thi...	M-25
63028	Forged D-Ring w/Weld On Mounting Bracket, 5/8" Dia., 1" x 5" ...	M-25
63029	Tow Hook, Chrome 10,000 lbs.	M-25
63030	Tow Hook, Black 10,000 lbs.	M-25
63032	Replacement Part, Pintle Hook Mounting Hardware Kit	B-16, B-17
63033	Replacement Part, Mounting Hardware Kit for 4 Bolt Flange Lu...	B-16
63034	Safety Chain, Class I GWR 2,000 lbs. 72", S-Hooks, Both Ends...	M-24
63035	Safety Chain, Class III GWR 5,000 lbs. 72", Quick Links, Bot...	M-24
63036	Adjustable Lunette Ring with Channel, 3" Dia., 24,000 lbs. C...	B-16
63040	Receiver Mount Pintle Hook w/1-7/8" Ball, 2" Sq. Solid Shank...	B-17
63041	Receiver Mount Pintle Hook w/2" Ball, 2" Sq. Solid Shank (In...	B-17
63042	Receiver Mount Pintle Hook w/2-5/16" Ball, 2" Sq. Solid Shank...	B-17
63043	5 Ton Receiver Mount Pintle Hook, 2" Sq. Solid Shank, Rating...	B-17
63044	Receiver Mount Tow Hook, 2" Sq. Solid Shank, GWR 10,000 lbs...	B-17
63045	Tow Strap Mount, 2" Sq. Solid Shank, GWR 10,000 lbs. 7-3/8" ...	B-17
63046	Tow Strap Loop, 2" Sq. Solid Shank, GWR 8,000 lbs. 7-3/8" Le...	B-17
63047	Receiver Mount Tow Hook, 2" Sq. Hollow Shank, GWR 8,000 lbs...	B-17
63050	Replacement Part, Pintle Hook Replacement Ball, 1-7/8" x 1-1/4" ...	B-17
63051	Replacement Part, Pintle Hook Replacement Ball, 2" x 1-1/4" ...	B-17
63052	Replacement Part, Pintle Hook Replacement Ball, 2-5/16" x 1-1/4" ...	B-17
63056	Pintle Hook Receiver Mount, 2" Sq. Hollow Shank, 7-5/8" Leng...	B-15
63057	Pintle Hook Receiver Mount, 2" Sq. Solid Shank, 7-5/8" Lengt...	B-15
63058	Pintle Hook Receiver Mount, 2" Sq. Solid Shank, Deep Drop, 1...	B-15
63059	Pintle Hook Receiver Mount, 2" Sq. Solid Shank, 11-3/8" Leng...	B-15
63060	Adjustable Lunette Ring with Hardware, 3" Dia., 24,000 lbs. ...	B-16
63069	Combo Lock Set, 5/8" for 2" Sq. Receiver and 3/4" for Access...	4, B-2, B-12, B-22
63070	Adjustable Tri-Ball Ball Mount System w/Step, 2" Sq. Shank, ...	B-2, B-12
63071	Adjustable Dual Ball Mount System, 2" Sq. Shank, 2" Ball 10...	B-12
63072	Adjustable Pintle Mount, 14,000 lbs. (GTW)	B-15
63075	Adjustable Tri-Ball Ball Mount w/Step, 1-7/8" Ball 2,000 lbs...	B-2, B-12
63076	Adjustable Dual Ball Mount, 2" Ball 10,000 lbs. (GTW), 2-5/1"	B-2, B-12
6308	Replacement Part, U-Bolt Safety Chain Kit	G-10
63080	QSP™ Hitch Silencing System for 2" Sq. Receivers	B-2, B-19
63082	QSP™ Hitch Silencing System for 2" Sq. Receivers	B-2, B-19
63090	Anti-Rattle Device for 1-1/4" Sq. Receivers	B-19
63091	Anti-Rattle Device for 2" Sq. Receivers	B-19
63100	Lock-Tite Anti-Rattle Pin w/Lock & Wrench, 5/8" for 2" Sq. R...	B-19
63100-025	Lock-Tite Anti-Rattle Pin w/Lock & Wrench, 5/8" for 2" Sq. R...	B-19
63120	Eclipse™ Bike Carrier, 2 Bike, 1-1/4" Sq. Receiver Mount w/T...	I-5
63123	Eclipse™ Bike Carrier, 3 Bike, 1-1/4" Sq. or 2" Sq. Receiver...	I-5
63124	Eclipse™ Bike Carrier, 4 Bike, w/Tilt Function, 2" Sq. Recei...	I-5
63134	Q-Slot 2™ Bike Carrier, 2 Bike, Rail Rack, w/Tilt Function, 1...	I-4
63138	Q-Slot 4™ Bike Carrier, 4 Bike, Rail Rack, w/Tilt Function, ...	I-4
63148	Replacement Part, Bike Carrier Cradle for #63120, #63123, #6...	I-5
63150	Bullet Box™ Roof Top Luggage Carrier (13 cubic ft.)	I-11
63152	Rambler™ Cargo Carrier w/5-1/2" Side Rails, 24" x 60" Platfo...	I-2, I-8
63153	Rambler™ Cargo Carrier w/5-1/2" Side Rails, 24" x 60" Platfo...	I-8
63154	Rambler™ Cargo Carrier w/5-1/2" Side Rails, 20" x 48" Platfo...	I-8
63155	Rambler™ Cargo Carrier w/5-1/2" Side Rails, 20" x 48" Platfo...	I-8
63160	Replacement Part, Cargo Carrier #63152, #63153, #63154, #631...	I-8
63180	Adjustable Tow Bar, 5,000 lbs. GVW Capacity	M-27
63181	Adjustable Tow Bar w/Bolt Together 2-Piece Adjustment Arms, ...	M-27
63201	J-Pin™ Anti-Rattle Pin & Barrel Lockset for 2" Sq. Receivers	B-18
63202	1/2" Integral Pin & Clip for 1-1/4" Sq. Receivers - Stainless	B-18
63203	5/8" Integral Pin & Clip for 2" Sq. Receivers - Stainless	B-18
63204	1/2" Integral Pin & Clip for 1-1/4" Sq. Receivers - Zinc	B-18
63205	5/8" Integral Pin & Clip for 2" Sq. Receivers - Zinc	B-18
63216KA	Receiver Lock, Dead Bolt, 1/2" for 1-1/4" Sq. Receivers, Bla...	B-22
63217KA	Receiver Lock, Dead Bolt, 5/8" for 2" Sq. Receivers, Black F...	B-22
63218KA	Combo Lock Set, 1/2" Dead Bolt for 1-1/4" Sq. Receiver and T...	B-22
63219KA	Combo Lock Set, 5/8" Dead Bolt for 2" Sq. Receiver and Trail...	B-22
63220KA	Coupler Lock, Dead Bolt, 1/2" Span, Black Finish (Keyed Alik...	B-22
63221KA	Coupler Lock, Dead Bolt, 2" Span, Black Finish (Keyed Alike)...	B-22
63222KA	Coupler Lock, Dead Bolt Surge Brake, 2-3/8" Span, Black Fini...	B-22
63223	Receiver Lock, Bent Pin, 5/8" for 2" & 2-1/2" Sq. Receivers	B-21
63224	Receiver Lock, Bent Pin, 1/2" for 1-1/4" Sq. Receivers & Fif...	B-21
63225	Coupler Lock	B-22

PRODUCT NUMERICAL

PART NO.	DESCRIPTION	PAGE NO.
63227	Coupler Lock, "Gorilla Guard" for 2-5/16" Couplers	B-22
63228	Coupler Lock, "Gorilla Guard" for 2" Couplers	B-22
63233	Cable Lock, 5/16" x 10' Length	B-21
63234F	Receiver Lock, for 1-1/4", 2" & 2-1/2" Sq. Receivers w/Unive...	B-21
63240	Packaged 5/8" Grooved Style Hitch Pin and Clip for 2" Sq. Re...	B-18
63240-050	Bulk 5/8" Grooved Style Hitch Pin and Clip for 2" Sq. Receiv...	B-18
63241	Packaged 1/2" Grooved Style Hitch Pin and Clip for 1-1/4" Sq...	B-18
63241-050	Bulk 1/2" Grooved Style Hitch Pin and Clip for 1-1/4" Sq. Re...	B-18
63242	Packaged 5/8" Hole Style Hitch Pin and Clip for 2" Sq. Recei...	B-18
63242-050	Bulk 5/8" Hole Style Hitch Pin and Clip for 2" Sq. Receivers...	B-18
63242-100	Bulk 5/8" Hole Style Hitch Pin and Clip for 2" Sq. Receivers...	B-18
63242-500	Bulk 5/8" Hole Style Hitch Pin and Clip for 2" Sq. Receivers...	B-18
63243	Packaged 5/8" Grooved Style Hitch Pin and Clip for Titan® 2-...	B-18
63248	Receiver Lock, Barrel Style w/Bent Pins, 1/2" for 1-1/4" Sq...	B-21
63249F	Combo Lock Set, Barrel Style w/Bent Pins, 1/2" for 1-1/4" Sq...	B-22
63250	Combo Lock Set, Dogbone Style, 1/2" for 1-1/4" Sq. Receivers...	B-22
63251	Fifth Wheel King Pin Lock	F-18
63252	Receiver Lock, Dogbone Style, 5/8" for 2-1/2" Sq. Receivers...	B-21
63253	Receiver Lock, Barrel Style w/Bent Pin, 5/8" for 2-1/2" Sq. ...	B-21
63254	Fifth Wheel Base Rails Lock, Barrel Style w/Bent Pin, 1/2"	F-18
63255	Cable Lock, 5/16" x 4' Length	B-21
63256	Receiver Lock, Keyed Alike Lock Set (Set Includes #63226 & #...	B-22
63300	Solo Hitch Alignment System	B-5, M-23
63604	Amigo™ Hitch Cargo Carrier Bag	I-13
63801	Interchangeable Hitch Ball, 3/4" Shank, 1-7/8" & 2" Balls, 5...	B-5
63802	Interchangeable Hitch Ball, 1" Shank, 1-7/8" & 2" Balls, 8.0...	B-5
63803	Interchangeable Hitch Ball, 1" Shank, 1-7/8", 2", & 2-5/16" ...	B-5
63804	Interchangeable Hitch Ball, 1" Shank, 2" & 2-5/16" Balls, 8...	B-5
63805	Replacement Part, Interchangeable Hitch Ball, 1-7/8" Replace...	B-5
63806	Replacement Part, Interchangeable Hitch Ball, 2" Replacement...	B-5
63807	Replacement Part, Interchangeable Hitch Ball, 2-5/16" Replac...	B-5
63808	Replacement Part, Interchangeable Hitch Ball, 3/4" Replacem...	B-5
63809	Replacement Part, Interchangeable Hitch Ball, 1" Replacement...	B-5
63810	Hitch Ball, 1-7/8" x 3/4" x 1-1/2", 2,000 lbs. GTW Chrome	B-4
63810-006	Hitch Ball, 1-7/8" x 3/4" x 1-1/2", 2,000 lbs. GTW Chrome (6...	B-4
63811	Hitch Ball, 1-7/8" x 3/4" x 1-1/2", 2,000 lbs. GTW Zinc	B-4
63812	Hitch Ball, 1-7/8" x 3/4" x 2-3/8", 2,000 lbs. GTW Chrome	B-4
63813	Hitch Ball, 1-7/8" x 3/4" x 2-3/8", 2,000 lbs. GTW Zinc	B-4
63814	Hitch Ball, 1-7/8" x 3/4" x 3-3/8", 2,000 lbs. GTW Chrome	B-4
63816	Hitch Ball, 1-7/8" x 1" x 2-1/8", 2,000 lbs. GTW Chrome	B-4
63816-006	Hitch Ball, 1-7/8" x 1" x 2-1/8", 2,000 lbs. GTW Chrome (6 p...	B-4
63817	Hitch Ball, 1-7/8" x 1" x 2-1/8", 2,000 lbs. GTW Zinc	B-4
63818	Hitch Ball, 1-7/8" x 1" x 3-3/8", 2,000 lbs. GTW Chrome	B-4
63819	Hitch Ball, 1-7/8" x 1" x 3-3/8", 2,000 lbs. GTW Zinc	B-4
63820	Hitch Ball, 2" x 3/4" x 1-1/2", 3,500 lbs. GTW Chrome	B-4
63821	Hitch Ball, 2" x 3/4" x 1-1/2", 3,500 lbs. GTW Zinc	B-4
63822	Hitch Ball, 2" x 3/4" x 2-3/8", 3,500 lbs. GTW Chrome	B-4
63823	Hitch Ball, 2" x 3/4" x 2-3/8", 3,500 lbs. GTW Zinc	B-4
63824	Hitch Ball, 2" x 3/4" x 3-3/8", 3,500 lbs. GTW Chrome	B-4
63830	Hitch Ball, 2" x 1-1/4" x 2-3/4", 8,000 lbs. GTW Chrome	B-4
63831	Hitch Ball, 2" x 1-1/4" x 2-3/4", 8,000 lbs. GTW Zinc	B-4
63834	Hitch Ball, 2-5/16" x 1-1/4" x 2-3/4", 12,000 lbs. GTW Chrome	B-4
63835	Hitch Ball, 2-5/16" x 1-1/4" x 2-3/4", 12,000 lbs. GTW Zinc	B-4
63836	Hitch Ball, 2-5/16" x 1-1/4" x 2-3/4", 14,000 lbs. GTW Chrome	B-4
63840	Hitch Ball, 2-5/16" x 1-1/4" x 2-3/4", 20,000 lbs. GTW Chrome	B-4
63845	Hitch Ball, 2" x 1" x 2-1/8", 7,500 lbs. GTW Chrome	B-4
63845-006	Hitch Ball, 2" x 1" x 2-1/8", 7,500 lbs. GTW Chrome (6 pack)	B-4
63846	Hitch Ball, 2-5/16" x 1" x 2-1/8", 7,500 lbs. GTW Zinc	B-4
63847	Hitch Ball, 2-5/16" x 1" x 2-1/8", 7,500 lbs. GTW Chrome	B-4
63847-006	Hitch Ball, 2-5/16" x 1" x 2-1/8", 7,500 lbs. GTW Chrome (6 ...	B-4
63848	Hitch Ball, 2" x 1" x 2-1/8", 7,500 lbs. GTW Zinc	B-4
63849	Hitch Ball, 2" x 1" x 3-3/8", 7,500 lbs. GTW Chrome	B-4
63850	Hitch Ball, 2" x 1" x 3-3/8", 7,500 lbs. GTW Zinc	B-4
63851	Packaged Hitch Ball, 1-7/8" x 1" x 2-1/8", 2,000 lbs. GTW St...	B-4
63852	Packaged Hitch Ball, 2" x 1" x 2-1/8", 6,000 lbs. GTW Stainl...	B-4
63853	Packaged Hitch Ball, 2-5/16" x 1" x 2-1/8", 6,000 lbs. GTW S...	B-4
63880	Packaged Hitch Ball, 1-7/8" x 3/4" x 1-1/2", 2,000 lbs. GTW ...	B-4
63881	Packaged Hitch Ball, 1-7/8" x 3/4" x 1-1/2", 2,000 lbs. GTW ...	B-5
63882	Packaged Hitch Ball, 1-7/8" x 3/4" x 2-3/8", 2,000 lbs. GTW ...	B-4
63884	Packaged Hitch Ball, 1-7/8" x 1" x 2-1/8", 2,000 lbs. GTW Ch...	B-4
63885	Packaged Hitch Ball, 1-7/8" x 1" x 2-1/8", 2,000 lbs. GTW Zinc	B-4
63887	Packaged Hitch Ball, 2" x 3/4" x 1-1/2", 3,500 lbs. GTW Chrome	B-4
63888	Packaged Hitch Ball, 2" x 3/4" x 1-1/2", 3,500 lbs. GTW Zinc	B-4
63889	Packaged Hitch Ball, 2" x 3/4" x 2-3/8", 3,500 lbs. GTW Chrome	B-4
63896	Packaged Hitch Ball, 2-5/16" x 1-1/4" x 2-3/4", 12,000 lbs. ...	B-4
63897	Packaged Hitch Ball, 2-5/16" x 1-1/4" x 2-3/4", 12,000 lbs. ...	B-4
63899	Packaged Hitch Ball, 2" x 1-1/4" x 2-3/4", 8,000 lbs. GTW Ch...	B-6
63907	Packaged Hitch Ball, 2-5/16" x 1" x 2-1/8", 7,500 lbs. GTW Zinc	B-4

PART NO.	DESCRIPTION	PAGE NO.
63908	Packaged Hitch Ball, 2-5/16" x 1" x 2-1/8", 7,500 lbs. GTW C...	B-4
63909	Packaged Hitch Ball, 2" x 1" x 2-1/8", 7,500 lbs. GTW Chrome	B-7
63910	Packaged Hitch Ball, 2" x 1" x 2-1/8", 7,500 lbs. GTW Zinc	B-4
63911	Wt. Dist. Shank, 12,000 lbs. (GTW), 1,200 lbs. (TW), 11" Length	B-12, B-15, E-15
63912	Hitch Ball, 50mm x 3/4" x 1-1/2", w/Castle Nut & Cotter Pin ...	B-4
63971	Wt. Dist. Shank, 15,000 lbs. (GTW), 1,500 lbs. (TW), 14" Len...	E-15
64 0801	Kit-44305R Coupler Replacement	J-48
6425	Template for #8339 Folding Gooseneck Installation, Stainless...	G-10
6431	Receiver Tube Cover, 2" Sq., Chevrolet Logo	B-24
6432	Receiver Tube Cover, 2" Sq., Dodge Ram Logo	B-24
6433	Receiver Tube Cover, 2" Sq., Ford Logo	B-24
64-50-001	Support Mounting Bracket	K-40
6495	Front Mount Receiver Accessory, Winch Mounting Plate	A-12, J-65
6502	StrongArm™ Folding Cargo Carrier for 2" Sq. Receivers, 20" x...	I-10
6504	Light Kit for Cargo Carrier, Contains Lights, Wiring and Lic...	I-8, I-9, I-10, I-12
65509	600 lbs. Heavy Duty Round Bar WD Hitch w/#54970 Shank	E-10, O-4
6562	7-Way Blade Tester and Trailer Emulator w/LED Display	C-37
6565	Tekonsha Current Monitor	C-37
6580	Adjustable Ball Mount, 6,000 lbs. GTW, 1" Ball Hole, 12" Len...	B-11
66 0801	Replacement Part, 2" Wedge-Latch, Includes Latch, Lever, Bal...	J-41, L-11
66006	Titan®, Trunnion Bar Bolt-Together Wt. Dist. Kit, 17,000 lbs...	E-11, O-3
66009	Replacement Part, 1200 lbs. High-Performance Spring Bar & Tr...	E-9, O-3
66010	Replacement Part, 1700 lbs. High-Performance Spring Bar & Tr...	O-3
66014	Replacement Part, Heavy-Duty Round Bar & High-Performance Tr...	O-3, O-4
66020	600 lbs. Adj. High-Performance Trunnion Style w/o Shank	E-9, O-3
66021	800 lbs. Adj. High-Performance Trunnion Style w/o Shank	E-9, O-3
66022	1200 lbs. Adj. High-Performance Trunnion Style w/o Shank	E-9, O-3
6604	Grease Seal	M-9, M-17
6605	Grease Seal	M-9, M-17
66072	Strait-Line® 600 lbs. Trunnion Bar (includes #66020 & #26002)	E-6
66073	Strait-Line® 800 lbs. Trunnion Bar (includes #66021 & #26002)	E-6
66074	Strait-Line® 1200 lbs. Trunnion Bar (includes #66022 & #26002)	E-6
66075	Strait-Line® 1700 lbs. Trunnion Bar (includes #66006 & #26002)	E-2, E-6
66082	Strait-Line® 600 lbs. Trunnion Bar w/Shank (includes #66540 ...	E-6
66083	Strait-Line® 800 lbs. Trunnion Bar w/Shank (includes #66541 ...	E-6
66084	Strait-Line® 1200 lbs. Trunnion Bar w/Shank (includes #66542...	E-6
66086	Strait-Line® 600 lbs. Round Bar w/Shank (includes #65509 & #...	E-6
66087	Strait-Line® 800 lbs. Round Bar w/Shank (includes #67509 & #...	E-6
66088	Strait-Line® 1200 lbs. Round Bar w/Shank (includes #61009 & ...	E-6
66130	Strait-Line® 1500 lbs. Trunnion Bar Hitch (includes #66131 & ...	E-6
66131	Ultra Frame™, Trunnion Bar Bolt-Together Wt. Dist. Kit, 15.0...	E-9, O-3
66151	Reese SC™ 600 lbs. Trunnion Bar Wt. Dist. Kit & Built In Frict...	E-7, O-2
66153	Reese SC™ 800 lbs. Trunnion Bar Wt. Dist. Kit & Built In Frict...	E-7, O-2
66155	Reese SC™ 1200 lbs. Trunnion Bar Wt. Dist. Kit & Built In Frict...	E-7, O-2
66157	Reese SC™ 1500 lbs. Trunnion Bar Wt. Dist. Kit & Built In Frict...	E-7, O-2
6637	Replacement Part, Wt. Dist. Part, Lift Unit Kit, (2) Bracket...	E-2, E-9, E-10, E-16
66540	600 lbs. Adj. High-Performance Trunnion Style w/#54970 Shank	E-9, O-3
66541	800 lbs. Adj. High-Performance Trunnion Style w/#54970 Shank	E-9, O-3
66542	1200 lbs. Adj. High-Performance Trunnion Style w/#54970 Shank	E-9, O-3
66557	STEADI-FLEX® Light Weight Distributing Kit w/Shank, Built In...	E-8, O-5
66558	STEADI-FLEX® Light Weight Distributing Kit w/Shank, Built In...	E-8, O-5
66559	STEADI-FLEX® Weight Distributing Kit w/Shank, Built In Frict...	E-8
66560	STEADI-FLEX® Weight Distributing Kit w/Shank, Built In Frict...	E-8
66561	STEADI-FLEX® Weight Distributing Kit w/Shank, Built In Frict...	4, E-2, E-8
6658	Grease Cap	M-9, M-17
67 0801	Replacement Part, 2-5/16" Wedge-Latch, Includes Latch, Lever...	J-41, L-11
6709TEK	Brake Assembly - Alko 10" x 2-1/4" L/H	M-7, M-9, M-17
6710	Brake Assembly - Alko 10" x 2-1/4" R/H	M-7, M-9, M-17
6713	Brake Assembly - Alko 12" x 2" L/H	M-7, M-9, M-17
6714	Brake Assembly - Alko 12" x 2" R/H	M-7, M-9, M-17
6715	Front Mount Receiver Accessory, Spare Tire Carrier	A-12
67509	800 lbs. Heavy Duty Round Bar WD Hitch w/#54970 Shank	E-10, O-4
67518	Front Mount Receiver Accessory, Work Step	A-12
6771	Front Mount Receiver Accessory, Receiver Tube Skid Shield	A-12
6810	Rotabroach Hole Cutting Tool, 1/2" Diameter	A-11
6811	Rotabroach Hole Cutting Tool, 9/16" Diameter	A-11
6811S00	Service Kit, 6" Plastic Wheel	J-37
6927	Primus™ Mounting Dash Clip	D-10
69801	Front Mount Receiver Accessory, Handle Kit for #6495 Winch M...	A-12
6985	Replacement Part, Handle Grip for #6980 Handle Kit	A-12, J-65
7000	Battery Switch, 3 Terminal, 12 Volt Continuous Duty	C-36
7000100	Trailer Accessory, Tire Chocks (Order In 6 Pair Multiple Only)	M-2, M-23
7000-S	Battery Switch, 3 Terminal, 12 Volt Continuous Duty	C-36
7001	Battery Switch, 4 Terminal, 12 Volt Continuous Duty - Insula...	C-36
7001-S	Battery Switch, 4 Terminal, 12 Volt Continuous Duty - Insulated	C-36

PRODUCT NUMERICAL

PART NO.	DESCRIPTION	PAGE NO.
7010	Rubber Economy Receiver Tube Cover w/"D" Logo for 2" Sq. Rec...	B-23
7010A	Circuit Breaker, 15 Amp	C-35
7010A-S	Circuit Breaker, 15 Amp	C-35
7011800300	Weld-On 2.5" O.D. Male Mount, 3/4" Pin for 190's	J-8
7011A	Circuit Breaker, 20 Amp	C-35
7011A-S	Circuit Breaker, 20 Amp	C-35
7012A	Circuit Breaker, 30 Amp	C-35
7012A-S	Circuit Breaker, 30 Amp	C-35
7013A	Circuit Breaker, 40 Amp	C-35
7013A-S	Circuit Breaker, 40 Amp	C-35
701466	Crank Assembly, 2-Speed	J-16, J-29
702275	5-Flat Trailer End Connector, 25' Wishbone Harness, 4' Groun...	C-19
7022A	Circuit Breaker, 50 Amp	C-35
7022A-S	Circuit Breaker, 50 Amp	C-35
702305	5-Flat Car End Connector, 4' Wishbone Harness, 18" Ground, 4...	C-19
702405	5-Flat Trailer End Connector, 18" Wunsid Harness, 18" Groun...	C-19
70-38-010	Reflector 3-3/16" Round Adhesive Mount Red	K-41
70-38-020	Reflector 3-3/16" Round Adhesive Mount Amber	K-41
7050	Rubber Economy Receiver Tube Cover w/"D" Logo for 2" Sq. Rec...	B-23
70-55-010	Reflector 2-3/16" Round Adhesive Mount Red	K-41
70-55-020	Reflector 2-3/16" Round Adhesive Mount Amber	K-41
70-68-010	Round 3-3/16" Red Reflector w/Center Mount	K-41
70-68-020	Round 3-3/16" Amber Reflector w/Center Mount	K-41
707103	4-Flat Trailer End Connector, 25' Wishbone Harness Kit, 3' G...	C-15
707104	4-Flat Trailer End Connector, 30' Wishbone Harness Kit, 3' G...	C-15
707105	5-Flat Trailer End Connector, 25' Wishbone Harness Kit w/Har...	C-19
70-71-170	Round 2-3/16" Red Reflector w/Center Mounting Hole	K-41
70-71-175	Round 2-3/16" Amber Reflector w/Center Mounting Hole	K-41
70-71-180	Rectangular 3-1/4" x 1-1/2" Red Reflector w/Adhesive Mount	K-41
70-71-181	Rectangular 3-1/4" x 1-1/2" Amber Reflector w/Adhesive Mount	K-41
70-72-020	Reflector Clear Conspicuity 1.1" x 12"	K-41
70-72-030	Reflector Red Conspicuity 1.1" x 12"	K-41
707250	7-Way Blade to 5-Flat, 18" Wire Adapter	C-28
707254	4-Flat Extension Harness, 2' Long	C-15
707255	5-Flat Plug Loop 24" Long, Car & Trailer End Wiring Harness	C-19
707261	4-Flat Trailer End Connector, 25' Wishbone Harness, 3' Ground	C-15, K-7, K-8, K-18
707270	4-Flat Trailer End Connector, 18" Wishbone Harness, 18" Grou...	C-15
707272	4-Flat Car End Connector 72" Long, 72" Ground (Includes Wire...	C-15
707273	5-Flat Car End Connector, 6' Long, 6' Ground, 6' Auxiliary	C-19
707275	4-Flat Car End Connector 48" Long, 18" Ground	C-15, K-7, K-8, K-15, K-18, K-20
707281	6-Way Round Pin to 4-Flat Adapter	C-28
707282	7-Way Blade to 4-Flat Adapter	C-28
707283	5-Flat Trailer End Connector, 4' Wishbone Harness, 4' Ground...	C-19
707285	4-Flat Trailer End Connector, 18" Wunsid Harness, 18" Ground	C-15
707286	4-Flat Trailer End Connector, 18" Wishbone Harness, 18" Ground	C-15
707295	Taillight Converter w/12" Leads and 60" 4-Flat Car End Conne...	C-13
70-78-010	Reflector Oblong Red with Mounting Holes and Adhesive Back	K-41
70-78-020	Reflector Oblong Amber with Mounting Holes and Adhesive Back	K-41
70-78-050	Reflector Oblong Red with Mounting Holes Only	K-41
70-78-060	Reflector Oblong Amber with Mounting Holes Only	K-41
71-55-010	Reflector 2-3/16" Round Adhesive Mount Red	K-41
71-55-020	Reflector 2-3/16" Round Adhesive Mount Amber	K-41
71-78-010	Reflector Rectangular Red 3-1/4" x 1-1/2" - Adhesive	K-41
71-78-020	Reflector Rectangular Amber 3-1/4" x 1-1/2" - Adhesive	K-41
719063	Replacement Part, Plug, 3-Way 10-1/2"	K-7, K-8, K-9, K-17, K-22, K-35
7200	ElectroTek™ Non-Conductive Dielectric Silicone Compound, 3 O...	C-35
7200P	ElectroTek™ Non-Conductive Dielectric Silicone Compound, 3 O...	C-35
7390	Adjustable Ball Mount w/Sway Control Tab, 6,000 lbs. GTW, 1...	B-11
74099	Receiver Tube Cover for 2" Sq., Elite Black Nylon	B-24
74342	Wrench for Hitch Balls, Boxed Ends, 1-1/8" & 1-1/2"	A-11, B-4, B-14
74-38-010	Reflector 3-3/16" Round Adhesive Mount Red	K-41
74-38-020	Reflector 3-3/16" Round Adhesive Mount Amber	K-41
74547	Receiver Tube Cover for 2" Sq., Plastic	B-24
74-55-010	Reflector 2-3/16" Round Adhesive Mount Red	K-41
74-55-020	Reflector 2-3/16" Round Adhesive Mount Amber	K-41
74-68-010	Reflector 3-3/16" Round Center Mount Red	K-41
74-68-020	Reflector 3-3/16" Round Center Mount Amber	K-41
74700	Quick-Link Chain Hook-Up, Class III, 5/16"	M-25
74-71-170	Reflector 2-3/16" Round Center Mount Red	K-41
74-71-175	Reflector 2-3/16" Round Center Mount Amber	K-41
74-71-180	Reflector Rectangular Red 3-1/4" x 1-1/2" - Adhesive	K-41
74-71-181	Reflector Rectangular Amber 3-1/4" x 1-1/2" - Adhesive	K-41

PART NO.	DESCRIPTION	PAGE NO.
74-72-020	Reflector Clear Conspicuity - 4 per	K-41
74-72-030	Reflector Red Conspicuity - 4 per	K-41
74-72-040	Reflector Red & Clear Conspicuity - 2 ea. Per	K-41
74-78-010	Reflector Oblong Red with Mounting Holes and Adhesive Back	K-41
74-78-020	Reflector Oblong Amber with Mounting Holes and Adhesive Back	K-41
7585	Tekonsha Bench Tester	C-37
767940	7-Way Blade to 5-Flat Adapter	C-28
767941	4-Flat Car End Tester w/LED Display	C-37
767943	7-Way Blade Tester and Trailer Emulator w/LED Display	C-37
7685	Prodigy® Mounting Bracket Kit	D-10
7686	Replacement Part, Prodigy® Mounting Pocket Kit	D-10
78007	7-Way Flat Pin to 4-Flat Adapter w/42" Retractable 4-Flat	C-30
78117	7-Way Flat Pin to 4-Flat Adapter w/Tow-Glo & Dust Cover	C-30
78118	7-Way Flat Pin to 4 & 5-Flat Adapter w/LED Circuit Tester & ...	C-30
787159	4-Flat Trailer End w/4 Square Car End Loop, 88" Jacketed Cable	C-18
787194	5-Flat To 5-Flat 4' Coiled Adapter	C-28
787195	7-Way Flat Pin to 5-Flat 4' Coiled Adapter	C-28
787196	7-Way Flat Pin to 5-Flat 8' Coiled Adapter	C-28
787206	5-Flat to 5-Flat Coiled Adapter, 4' Long	C-28
787207	7-Way Flat Pin to 5-Flat Coiled Adapter, 4' Long	C-28
787208	7-Way Flat Pin to 5-Flat Coiled Adapter, 8' Long	C-28
787264	4-Flat Trailer End Connector, 4' Jacketed Cable	C-18
787268	4-Flat Trailer End Connector, 8' Jacketed Cable	C-18
787270	4-Flat Trailer End Connector, 10' Jacketed Cable	C-18
787274	4-Flat Trailer End Connector, 14' Jacketed Cable	C-18
787301	4-Flat Dust Cover	C-18
787302	7-Way Round Pin Ag Trailer End Connector	L-6
787303	7-Way Round Pin Ag Vehicle End Connector	L-6
787304	7-Way Round Pin Ag Trailer End Connector	L-6
787305	7-Way Round Pin Ag Vehicle End Connector	L-6
787535	7-Way Junction Box	C-34
7894	Replacement Part, Prodigy®, P3® and Primus™ 3 ft. Pigtail Ha...	D-10
800075	Topwind Crank Assembly for 180	J-16, J-26
800090	Sidewind Crank Assembly for 180 - Horizontal Clevis - Mounti...	J-16, J-26
800102	Mounting Hardware Included, Black Primed Finish, Horizontal ...	J-16, J-26
8001090283	Crank Handle, Mounting Hardware Included, Black Prime Finish...	J-23, J-29
800144	Replacement Part, Handle, Gear & Bushing Kit	J-30
800148	Jack Accessory, Sidewind Crank, 13-1/2" Radius w/Soft Touch ...	J-29
80037	Class III/IV 2" Sq. Receiver Cover w/Hidden Hitch Logo, Rubber	B-23
80037-012	Class III/IV 2" Sq. Receiver Cover w/Hidden Hitch Logo, Rubb...	B-23
80058-002	Towing Starter Kit, w/Quick-Loading 2" Sq. Ball Mount, 7,500...	B-9
8010	Trailer Tester	C-37
80100	Reducer Bushing 1" to 3/4"	B-14
80106	Reducer Bushing 1-1/4" to 1"	B-14
802650	Replacement Part, Amber Lens for #82600 Series Ag Light	L-4
802651	Replacement Part, Red Lens for #82600 Series Ag Light	L-4
802652	Replacement Part, Black/Blank Lens for #82600 Series Ag Light	L-4
80300	Receiver Adapter, Reduces 2" to 1-1/4", 7" Length, 3,500 lbs.	B-14
80301	Receiver Adapter, Reduces 2" to 1-1/4", 14" Length, 3,500 lbs.	B-14
80303	Receiver Adapter, 1-1/4" to 2", 6" Length, 3,500 lbs., Class...	B-14
80304	Receiver Adapter, 1-1/4" to 2", 10" Length, 3,500 lbs., Clas...	B-14
80305	Receiver Extension, 2" to 2" Extension, 14" Length, 3,500 lbs.	B-14
80306	Receiver Extension, 2" to 2" Extension, 18" Length, 3,500 lbs.	B-14
80307	Receiver Extension, 2" to 2" Extension, 8" Length, 3,500 lbs.	B-14
80400	Bumper Guard, Black	B-14
80404	Dual-Ball Ball Mount, 2" Sq. Hollow Shank, 10" Length, w/Bla...	B-13
80406	Dual-Ball Ball Mount, 2" Sq. Hollow Shank, 10" Length, w/Bla...	B-13
80410	Clevis Ball Mount, 2" Sq. Hollow Shank, 11" Length, Rating 6...	B-17
80425	Tri-Ball Ball Mount, 2" Sq. Hollow Shank w/Black 1-7/8", 2"...	B-13
80426	Tri-Ball Ball Mount, 2" Sq. Hollow Shank w/Chrome 1-7/8", 2"...	B-13
80470	Bumper Guard, Diamond Plate	B-14
80472-002	Towing Starter Kit, w/Quick-Loading 2" Sq. Ball Mount, 7,500...	B-9
80500	POD™ Brake Control, for 1 to 2 Axle Trailers, Timed Actuated	D-9
80550	Pilot® Brake Control, for 1 to 3 Axle Trailers, Timed Actuated	D-9, P-9
80583-002	Towing Starter Kit, w/Quick-Loading 2" Sq. Ball Mount, 7,500...	B-9
80644-002	Towing Starter Kit, w/Quick-Loading 2" Sq. Ball Mount, 7,500...	B-9
80791	Tri-Ball Ball Mount, 2" Sq. Solid Shank w/Black 1-7/8", 2", ...	B-13
80795	Dual-Ball Ball Mount, 2" Sq. Solid Shank, 8" Length, w/Black...	B-13
80796	Dual-Ball Ball Mount, 2" Sq. Solid Shank, 8" Length, w/Black...	B-13
80797	Dual-Ball Ball Mount, 2" Sq. Solid Shank, 8" Length, w/Chrom...	B-13
80798	Dual Ball Ball Mount, 2" Sq. Solid Shank, 8" Length, w/Chrom...	B-13
80799	Tri-Ball Ball Mount, 2" Sq. Solid Shank w/Chrome 1-7/8", 2"...	B-13
80806	Receiver Fabrication Part, 6" Combo Bar 2" Sq. ID w/Collar, ...	A-10
80812	Receiver Fabrication Part, 12" Combo Bar 2" Sq. ID w/Collar...	A-10
80818	Receiver Fabrication Part, 18" Combo Bar 2" Sq. ID w/Collar...	A-10
80953	Receiver Tube Cover, 2" Sq., Black Plastic	B-24
80980	Receiver Tube Cover, 2" Sq., Brake Light w/4-Flat Plug	B-24
82201	Multi-Fit Motor Home Hitch, Fits Frames 47" to 71" Wide, Bla...	A-9

PRODUCT NUMERICAL

PART NO.	DESCRIPTION	PAGE NO.
8260001	Dual Ag Light w/Amber/Red/Blank, Includes Left Hand Molded T...	L-4
8260101	Dual Ag Light w/Red/Blank Amber/Amber, Includes Right Hand M...	L-4
8260501	Ag Light, Single w/Red/Black, Includes Molded Tri-Plug	L-4
8260502	Ag Light, Single w/Red/Black, Includes 2-Way Weather Pack	L-4
8260601	Ag Light, Single w/Amber/Amber, Includes Molded Tri-Plug	L-4
8260602	Ag Light, Single w/Amber/Amber, Includes 2-Way Weather Pack ...	L-4
8261001	Ag Light, Single w/Red/Black w/ Brake Light Function, Includ...	L-4
8261002	Ag Light, Single w/Red/Black w/Brake Light Function, Include...	L-4
8261501	Dual Ag Light w/Amber/Amber Red/Blank w/Brake Light Function...	L-4, L-5
8261601	Dual Ag Light w/Red/Blank Amber/Amber w/Brake Light Function...	L-4, L-5
8261605	Dual Ag Light w/Red/Blank Amber/Amber w/Brake Light Function...	L-4
83001	Elite™ Series Fifth Wheel 12" Round Lube Plate, 3/16" Thick	F-18
83002	Fifth Wheel 10" Round Lube Plate, 3/16" Thick	F-18
83003	Titan® 16K Fifth Wheel Lube Plate	F-7, F-18
83004	Titan® 16K Fifth Wheel 12" Thin Round Lube Plate, 1/8" Thick	F-7, F-18
83058-002	Towing Starter Kit, w/Quick-Loading 2" Sq. Ball Mount, 7,500...	B-9
83238-002	Towing Starter Kit, w/Quick-Loading 2" Sq. Ball Mount, 7,500...	B-9
8339	Fold-Down Gooseneck Hitch w/2-5/16" Ball, Rating 25,000 lbs.	G-7
83407-002	Towing Starter Kit, w/Quick-Loading 2" Sq. Ball Mount, 2,000...	B-9
83501	Brakeman® Compact Brake Control, for 1 to 2 Axle Trailers, T...	D-6
83504	Brakeman® IV Digital Brake Control, for 1 to 4 Axle Trailers...	D-6
83583-002	Towing Starter Kit, w/Quick-Loading 2" Sq. Ball Mount, 7,500...	B-9
83637	Drawbar Kit for OEM Dodge Magnum Hitch, Drawbar (2,000 lbs. ...	B-7
83644-002	Towing Starter Kit, w/Quick-Loading 2" Sq. Ball Mount, 7,500...	B-9
83660	Pro Series™ Friction Swap Control	E-14, O-8
85-767010	Oval Chrome Trim Snap Ring	K-10
86005	Rebuild Kit, Wearable Components for 16K & 19K Sidwinders	H-5, H-6
86016	Rebuild Kit, Wearable Components for 16K Revolution	H-8
86110	Rebuild Kit, Wearable Components for 10K Revolution	H-8
90-03-327	Replacement Part, Clearance Light Lens Red with Screws	K-33
90-03-328	Replacement Part, Clearance Light Lens Amber with Screws	K-20, K-33
90-03-336	Replacement Part, Taillight & Clearance Light Replacement Le...	K-18
9010500	Ratchet Tie Down - 1" x 10" (4 pack)	I-31
90160	Primus™ IQ Electronic Brake Control, for 1 to 3 Axle Trailer...	D-2, D-4, P-9
90195	P3® Electronic Brake Control, for 1 to 4 Axle Trailers, Prop...	D-2, D-3
90250	Prodigy® RF Electronic Brake Control, for 1 to 3 Axle Traile...	D-2, D-3, P-9
90251	Replacement Part, Prodigy® RF Hand Held Remote	D-3
9030	Voyager® Electronic Brake Control, for 1 to 4 Axle Trailers...	D-5, P-9
90885	Prodigy® P2 Electronic Brake Control, for 1 to 4 Axle Traile...	D-2, D-3, P-9
9250900	Anchor Point - Chrome	I-18
9251800	Anchor Point - Chrome	I-18
9252200	Anchor Point, fits all Chevrolet/GMC Silverado/Sierra, 1994-...	I-18
9412000	Fat Strap Cord - 20"	I-31
9413000	Fat Strap Cord - 30"	I-31
9414500	Fat Strap Cord - 45"	I-31
9414900	Adjustable Fat Strap - 10" to 45", Orange/Black	I-31
9424100	Universal Heavy Duty Truck Net	I-36
9424200	Cargo Net - Pickup Truck - 60" x 78"	I-36
9425900	Standard Duty Titan Cast Handle Ratchet Tie Down, 1 In. x 6 ...	I-34
9426001	Standard Duty, Titan Max Grip Cast Handle Ratchet Tie Down, ...	I-34
9426100	Standard Duty Titan Cast Handle Ratchet Tie Down, 1 In. x 10...	I-34
9426200	Heavy Duty Ratchet Tie Down with Max Grip Handle, 1 In. x 14...	I-34
9426400	Reflective Tow Strap with Loops, 20 Ft.	I-33
9429300	Tarp Strap Assortment, 6 Piece Jar	I-33
94316	Rebuild Kit, Wearable Components for Fifth Airborne Sidwinders	H-4
9460	Hide-A-Goose™ Wide Head	G-2, G-7
94622	Goose Box™ 16K Rated, 2-5/16" Gooseneck RV Coupler For Lipp...	G-3, H-3
94623	Goose Box™ 20K Rated, 2-5/16" Gooseneck RV Coupler For Lipp...	G-2, G-3, H-3
9464	Hide-A-Goose™ Wide Head	G-7
9465	Hide-A-Goose™ Narrow Head	G-7
9480	Hide-A-Goose™ 18K Hi-Rise™ Fifth Wheel Conversion Hitch	G-8
9514600	Super Duty Ratchet 1.5 In. x 7 Ft.	I-33
9527300	Bungee Cord Assortment, 24 Piece Jar	I-32
9528600	TRI STRENGTH BUNGEE 18" 2 PK	I-32
9528800	Straps	I-32
9534000	Straps	I-33
A2003C0317	Adjustable Coupler, Cast Head, w/Hardware, 3 Position Channe...	J-41, L-11
A2005C0317	Adjustable Coupler, Cast Head, w/Hardware, 5 Position Channe...	J-41, L-11
A200C 0317	Adjustable Coupler, Cast Head, w/Hardware, Less Channel, 800...	J-41, L-11
A200S 0303	Adjustable Coupler w/Hardware, Less Channel, 8000 lbs. - Black	J-42, L-12
A2563C0317	Adjustable Coupler, Cast Head, w/Hardware, 3 Position Channe...	J-41, L-11
A2565C0317	Adjustable Coupler, Cast Head, w/Hardware, 5 Position Channe...	J-41, L-11
A256C 0317	Adjustable Coupler, Cast Head, w/Hardware, Less Channel, 14...	J-41, L-11
A256S 0303	Adjustable Coupler w/Hardware, Less Channel, 14,000 lbs. - B...	J-42, L-12
AC300 0300	4 Hole, 3 Position Channel, w/8" Height	J-41, J-42, L-11, L-12
AC500 0300	6 Hole, 5 Position Channel, w/11-3/4" Height	J-41, J-42, L-11, L-12

PART NO.	DESCRIPTION	PAGE NO.
BB17810112	Bearing Protector Covers, 1.781"	M-19
BB19800112	Bearing Protector Covers, 1.980"	M-19
BB19800312	Bearing Protector Covers, 1.980"	M-19
BB24410112	Bearing Protector Covers, 2.328" & 2.441"	M-19
BB24410312	Bearing Protector Covers, 2.328" & 2.441"	M-19
BGR20 0101	Roller Guides Kit (a pair)	M-22
BP198S0304	Bearing Protector, 1.980"	M-19
BP232S0304	Bearing Protector, 2.328"	M-19
BP232S0604	Bearing Protector, 2.328"	M-19
BP244S0304	Bearing Protector, 2.441"	M-19
BP244S0604	Bearing Protector, 2.441"	M-19
BPC1780604	Bearing Protector, 1.781" w/Covers	M-19
BPC1980604	Bearing Protector, 1.980" w/Covers	M-19
CA5550301	Caster Adapter Plate - used w/HC1 & HDC1	J-27
CE555 0101	6" Caster - Fits 2" Round Inner Tube - 1200 lbs.	J-8, J-27
CE555 0301	6" Caster - Fits 2" Round Inner Tube - 1200 lbs. Zinc	J-8, J-27
CH 0701	Coupler Handle, Carded	J-48
CHA0010140	Safety Chain, Grade 30, 1/4" x 24" w/S-Hook w/Latch	M-24
CHA0010340	Safety Chain, Grade 30, 1/4" x 24" w/ 7/16" Wire Safety Latch	M-24
CHA0020324	Safety Chain, Grade 70, 1/4" x 36" w/ 1/4" Clevis Hook	M-24
CHA0030140	Safety Chain, Grade 43, 1/4" x 24" w/S-Hook w/Latch	M-24
CHA0030340	Safety Chain, Grade 43, 1/4" x 24" w/ 7/16" Wire Safety Latch	M-24
CHA0040324	Safety Chain, Grade 70, 5/16" x 36" w/ 5/16" Clevis Hook	M-24
CHA0050324	Safety Chain, Grade 70, 5/16" x 42" w/ 5/16" Clevis Hook	M-24
CHA0060324	Safety Chain, Grade 70, 3/8" x 36" w/ 3/8" Clevis Hook	M-24
CHA0070324	Safety Chain, Grade 70, 1/2" x 42" w/ 1/2" Clevis Hook	M-24
CLK15 0100	Cable Lock w/Key, 15'	B-21
CP555 0301	6" Caster - Fits 2" Round Inner Tube - 1500 lbs.	J-27
CR8008	Bunk Carpeting, 8' x 144"	M-22
CR8012	Bunk Carpeting, 12' x 144"	M-22
CS730300	Cross Shaft Tube w/Slotted Ends & Mounting Hardware, 72-3/4"...	J-16, J-23
DF35000324	Drop Leg, 3,500 lbs. SQ Tube	J-28
E112000340	Coupler, Straight Channel, Ball Size 1-7/8", 2" Tongue Mount...	J-48
E112500340	Coupler, Straight Channel, Ball Size 1-7/8", 2-1/2" Tongue M...	J-48
E113000340	Coupler, Straight Channel, Ball Size 1-7/8", 3" Tongue Mount...	J-48
E333050303	Coupler, A-Frame, 5,000 lbs., Class III, Value Series, Black...	J-48
E338050303	Coupler, A-Frame, Yoke-Style, 5,000 lbs., Class III, Black P...	J-42, L-12
E438050303	Coupler, A-Frame, Yoke-Style, 8,000 lbs., Class IV, Black Pr...	J-42, L-12
E443050303	Coupler, A-Frame, 10,000 lbs., Class IV, Value Series, Black...	J-48
EA2000103	2000 lbs., TW, A-Frame, 14" Travel, Black	J-9
EA2000303	2000 lbs., TW, A-Frame, 14" Travel, Black	J-9
EA2000340	Jack, 2000 lbs., A-Frame	J-9
EJ10000101	1000 lbs., Swivel, Zinc Plated, 6" Poly Wheel	J-36
EJ1000301	1000 lbs., Swivel, Zinc Plated, 6" Poly Wheel	J-36
ETC 0101	Spare Tire Carrier, Economy	M-26
ETCHL 0700	Spare Tire Carrier with Bracket	M-26
ETGLB 0700	Spare Tire Carrier, Economy w/Locking Brackets	M-26
ETCS1L0101	Spare Tire Carrier, Economy w/Lock (STL Lock Included)	M-26
F2000 0101	Footpad for 2,000/5,000 lbs. Jacks	J-28
F2000 0301	Footpad for 2,000/5,000 lbs. Jacks	J-28
F3500 0324	Foot Plate-SQ Tube	J-28
FP20000201	Disc Foot w/Hardware - 2,000 lbs.	J-28
FW16000101	F2™ Winch, 1600 lbs., w/Strap	J-51, J-52
FW160020301	F2™ Winch, 1600 lbs., w/Strap	J-52
FW20000101	F2™ Winch, 2000 lbs., w/Strap	J-51, J-52
FW20000301	F2™ Winch, 2000 lbs., w/Strap	J-52
FW32000101	F2™ Winch, 2-Speed, 3200 lbs., w/Strap	J-51, J-52
FW32000301	F2™ Winch, 2-Speed, 3200 lbs., w/Strap	J-52
FW3200S01	Replacement Part, F2™ Winch 2-Speed Sun Gear Kit for #FW3200...	J-52
GB150 0100	Boat Guide Kit, 50" (a pair)	M-22
GB44 0101	Boat Guide Kit, 44" (a pair)	M-22
GN24 0200	24K Cast Gooseneck Coupler Kit	J-44, L-14
HD25000101	2500 lbs., Square Tube, Fixed Mount	J-37
HD50000101	5000 lbs., Square Tube, Fixed Mount	J-37
HD50000301	5000 lbs., Square Tube, Fixed Mount	J-37
HDDS 0201	Shaft-Handle, Hex Drive-Zinc	J-29
HDPB230101	Fold-Away Bolt-On Hinge Kit, 2" x 3" Trailer Beam, Zinc Fini...	J-49
HDPB330101	Fold-Away Bolt-On Hinge Kit, 3" x 3" Trailer Beam, Zinc Fini...	J-49
HDPB330301	Fold-Away Bolt-On Hinge Kit, 3" x 3" Trailer Beam, Zinc Fini...	J-49
HDPB340101	Fold-Away Bolt-On Hinge Kit, 3" x 4" Trailer Beam, Zinc Fini...	J-49
HDPB340301	Fold-Away Bolt-On Hinge Kit, 3" x 4" Trailer Beam, Zinc Fini...	J-49
HDPB350101	Fold-Away Bolt-On Hinge Kit, 3" x 5" Trailer Beam, Zinc Fini...	J-49
HDPW230300	Fold-Away Weld-On Hinge Kit, 2" x 3" Trailer Beam, Raw Finis...	J-49
HDPW330300	Fold-Away Weld-On Hinge Kit, 3" x 3" Trailer Beam, Raw Finis...	J-49
HDPW340300	Fold-Away Weld-On Hinge Kit, 3" x 4" Trailer Beam, Raw Finis...	J-49
HDPW350300	Fold-Away Weld-On Hinge Kit, 3" x 5" Trailer Beam, Raw Finis...	J-49
HDSTC 0101	Spare Tire Carrier, Heavy Duty	M-26
JC1000300	J-Clip For Safety Chain	M-25

PRODUCT NUMERICAL

PART NO.	DESCRIPTION	PAGE NO.
KR10000301	Brake Winch, 1000 lbs., Standard Series	J-58
KR15000301	Brake Winch, 1500 lbs., Standard Series	J-58
OML 0127	Outboard Motor Lock	M-2, M-27
P20520-00	Mounting Bracket for Snap Ring Mount, 3/8" Pin	J-29
P9012-00	Mounting Bracket-1/2" Pin w/Lip	J-37
P9086-00	Replacement Part, Retaining Ring for Snap Ring Mount Jacks	J-30
P9222-00	Mounting Bracket for Snap Ring Mount, 1/2" Pin	J-8, J-29
PL4 0201	Pin/Lanyard-5/16" w/4 Link Chain & Tab	J-41, L-11
PQM19-00	Weld-On Male Mount, 5/8" Pin - fits 2.5" Square Mount	J-8
RV20000103	2000 lbs., SW, A-Frame, 14" Travel, Black	J-9
RV20000303	2000 lbs., SW, A-Frame, 14" Travel, Black	J-9
SJ1 0300	Stabilizer, 2" Sq. x 13"L, Raw	J-38, L-8
SJ2 0324	Stabilizer, 1.75" Sq. x 28.75", Adjusts from 25" to 37"	J-38, L-8
SJL8 0300	Stabilizer, 1.5" Square, Adjusts from 8" to 27"	J-38, L-8
SJW 0324	Stabilizer, 1.75" x 30.5"- Yellow Zinc	J-38, L-8
SPB50 0300	Bottom Support Plate w/2.29" Dia. Hole	J-27
SPBQ500300	Bottom Support Plate w/2.3" Dia. Square Hole	J-27
ST400	Sidewinder Turret w/Hardware	H-4, H-5, H-6
ST400-5AS16K	Fifth Airborne Sidewinder Combo	H-4
ST400-SW16K	Sidewinder Combo, Turret w/Hardware & Arm w/King Pin #ST400	H-5
ST400-SW19K	Sidewinder Combo, Turret w/Hardware & Arm w/King Pin #ST400	H-6
STC1000101	Spare Tire Carrier, Bolt-On	M-26
STC1000301	Spare Tire Carrier, Bolt-On	M-26
STL 0603	Spare Tire Lock	M-26
SW16K	Sidewinder 16K	H-5
SW19K	Sidewinder 19K	H-2, H-6
SWW-01	Sidewinder Wedge Kit, Elite™ Series	H-9
SWW-03	Sidewinder Wedge Kit, Select Series	H-9
SWW-04	Sidewinder Wedge Kit, Husky	H-9
SWW-05	Sidewinder Wedge Kit, Hi - Jacker	H-9
SWW-06	Sidewinder Wedge Kit, B&W	H-9
SWW-07	Sidewinder Wedge Kit, RBW	H-9
SWW-08	Sidewinder Wedge Kit, Colibert	H-9
SWW-09	Sidewinder Wedge Kit, Pullrite	H-9
TJ12000101	Swivel Jack, 1200 lbs., Bolt-On, 6" Wheel	J-36
TJ120W0301	Swivel Jack, 1200 lbs., Weld-On, 6" Wheel	J-36
TJ12220301	JACK-1200 lbs. FIXED MOUNT-	J-37
TK100 0100	Trailer Keeper Lock	B-20
WB100 0700	Wheel Bearing Kit, 1"	M-2, M-19
WB106 0700	Wheel Bearing Kit, 1-1/16"	M-19
WB13870700	Wheel Bearing Kit w/ Dust Cover, 1-3/8" & 1-1/16"	M-19
WC325 0100	3/16" x 25" Cable w/Hook	J-56, J-58
WC750 0100	7/32" x 50" Cable w/Hook	J-56, J-58
WS20HD0200	Winch Strap w/Hook, 2" x 20', Heavy Duty	J-54, J-56
WS20HD0600	Winch Strap w/Hook, 2" x 20', Heavy Duty	J-54, J-56
XP10 0101	Jack, 1200 lbs. Bolt-Thru Swivel Mount Sidewind w/6" Wheel	J-36
XP10 0301	Jack, 1200 lbs., Swing-Away, Bolt-On, Steel Construction, 10...	J-36
XP100W0301	Jack, 1200 lbs., Bolt-On Weld-On	J-36
XP10W 0301	Jack, 1200 lbs., Swing-Away, Weld-On, Steel Construction, 10...	J-36
XP10WC0301	Jack, 1200 lbs., Bolt-On 10" Weld-On	J-36
XP15 0101	Jack, 1500 lbs., Swing-Away, Bolt-On, Steel Construction, 10...	J-36
XP15 0301	Jack, 1500 lbs., Swing-Away, Bolt-On, Steel Construction, 10...	J-36
XP15L 0101	Jack, 1500 lbs., Swing-Away, Bolt-On, Steel Construction, 12...	J-36
XP15L 0301	Jack, 1500 lbs., Swing-Away, Bolt-On, Steel Construction, 12...	J-36
XP15W 0301	Jack, 1500 lbs., Swing-Away, Weld-On, Steel Construction, 10...	J-36
XP15WC0301	Jack, 1500 lbs., Weld-On, Independent Caster (Mounting Brack...	J-36
XPD15L0101	Jack, 1500 lbs., Swing-Away, Bolt-On, Steel Construction, 12...	J-36



BRAD KESELOWSKI

2017 NASCAR CAMPING WORLD TRUCK SERIES SCHEDULE

DATE	RACE	VENUE	TIME/TV (All Times Eastern)
FEBRUARY			
Feb. 24	Daytona International Speedway	NextEra Energy Resources 250	7:30pm / FOX Sports 1
MARCH			
Mar. 4	Atlanta Motor Speedway	Active Pest Control 200	4:30pm / FOX Sports 1
APRIL			
Apr. 1	Martinsville Speedway	Alpha Energy Solutions 250	2:30 pm / FOX Sports 1
MAY			
May 12	Kansas Speedway	Toyota Tundra 250	8:30pm / FOX Sports 1
May 19	Charlotte Motor Speedway	NC Education Lottery 200	8:30pm / FOX Sports 1
JUNE			
June 2	Dover International Speedway	Dover 200	5:30pm / FOX Sports 1
June 9	Texas Motor Speedway	Rattlesnake 400	8:00pm / FOX Sports 1
June 17	Gateway Motorsports Park	Drivin' for Linemen 200	8:30pm / FOX Sports 1
June 23	Iowa Speedway	American Ethanol 200	8:30pm / FOX Sports 1
JULY			
July 6	Kentucky Speedway	Kentucky 225	7:30pm / FOX Sports 1
July 19	Eldora Speedway	Aspen Dental 150	9:00pm / FOX Sports 1
July 19	Pocono Raceway	Pocono Mountains 150	1:00pm / FOX Sports 1
AUGUST			
Aug. 12	Michigan International Speedway	Careers for Veterans 200	1:00pm / FOX Sports 1
Aug. 16	Bristol Motor Speedway	UNOH 200	8:30pm / FOX Sports 1
SEPTEMBER			
Sept. 3	Canadian Tire Motorsports Park	Chevrolet Silverado 250	2:30pm / FOX Sports 1
Sept. 15	Chicagoland Speedway	Chicago 225	8:30pm / FOX Sports 1
Sept. 23	New Hampshire Motor Speedway	UNOH 175	1:00pm / FOX Sports 1
Sept. 30	Law Vegas Motor Speedway	Rhino Linings 350	8:30pm / FOX Sports 1
OCTOBER			
Oct. 14	Talladega Superspeedway	Fred's 250 Powered by Coca-Cola	1:00pm / FOX
Oct. 28	Martinsville Speedway	Alpha Energy Solutions 200	1:30pm / FOX Sports 1
NOVEMBER			
Nov. 3	Texas Motor Speedway	Longhorn 350	8:30pm / FOX Sports 1
Nov. 10	Phoenix International Raceway	Lucas Oil 150	8:30pm / FOX Sports 1
Nov. 17	Homestead-Miami Speedway	Ford EcoBoost 200	8:00pm / FOX Sports 1

BRENT CHAPMAN



2017 BASSMASTER ELITE TOURNAMENT SCHEDULE

DATE	TOURNAMENT	LOCATION	SERIES
JANUARY			
Jan. 19-21	Bass Pro Shops Southern Open #1	Harris Chain of Lakes, Leesburg, FL	Opens
FEBRUARY			
Feb. 9-12	Bassmaster Elite at Lake Cherokee	Lake Cherokee, Jefferson Co., TN	Elite
Feb. 23-26	Bassmaster Elite at Lake Okeechobee	Lake Okeechobee, Okeechobee, FL	Elite
MARCH			
March 2-4	Bass Pro Shops Central Open #1	Table Rock Lake, Branson, MO	Opens
March 24-26	GEICO Bassmaster Classic	Lake Conroe, Houston, TX	Classic
APRIL			
April 6-9	Bassmaster Elite at Toledo Bend	Toledo Bend Reservoir, Many, LA	Elite
April 20-22	Bass Master Pro Shops Southern Open #2	Lake Chickamauga, Dayton, TN	Opens
April 27-30	Bassmaster Elite at Ross Barnett	Ross Barnett Reservoir, Ridgeland, MS	Elite
MAY			
May 17-21	Toyota Bassmaster Texas Fest	Lake Sam Rayburn, Lufkin, TX	Elite
JUNE			
June 2-5	Bassmaster Elite at Dardanelle	Lake Dardanelle, Russellville, AK	Elite
June 15-17	Bass Pro Shops Central Open #2	Sabine River, Orange, TX	Opens
June 29 - July 1	Bass Pro Shops Northern Open #1	Oneida Lake, Syracuse, NY	Opens
JULY			
July 20-23	Bassmaster Elite at St. Lawrence	St. Lawrence River, Waddington, NY	Elite
July 27-30	Bassmaster Elite at Champlain	Lake Champlain, Plattsburgh, NY	Elite
AUGUST			
Aug. 3-5	Bass Pro Shops Northern Open #2	James River, Richmond, VA	Opens
Aug. 24-27	Bassmaster Elite at St. Clair	Lake St. Clair, Macomb Co., MI	Elite
SEPTEMBER			
Sept. 7-9	Bass Pro Shops Northern Open #3	Douglas Lake, Dandridge, TN	Opens
Sept. 28-30	Bass Pro Shops Southern Open #3	Smith Lake, Jasper, AL	Opens
OCTOBER			
Oct. 5-7	Bass Pro Shops Central Open #3	Grand Lake O' the Cherokees, Grove, OK	Opens



NICK VANS TRYDUNK

2017 USSA, ORA, CPTC AND EASTERN PRO TOUR SERIES SCHEDULE

DATE	RACE	LOCATION	SERIES
JANUARY			
Jan. 7-8	Ironwood Snowmobile Olympus	Gogebic County Fairgrounds, Ironwood, MI	TRL Cup
Jan. 19-22	AMSOIL Eagle River World Championships Snowmobile Derby	Eagle River Resort, Eagle River, WI	TRL Cup
Jan. 28-29	Wausau 525	Wausau 525, Wausau, WI	TRL Cup
FEBRUARY			
Feb. 3-4	The Winter Spectacular	Viking Speedway, Alexandria, MN	TRL Cup
Feb. 11-12	Grand Prix de Valcourt	Grand Prix Ski-doo of Valcourt, Valcourt, QC, Canada	TRL Cup
Feb. 18-19	Clash at the Creek	141 Speedway, Francis Creek, WI	TRL Cup
Feb. 25-26	Fire on Ice	Fire on Ice, Weyauwega, WI	TRI Cup
MARCH			
March 4-5	Canadian Power Toboggan Championships	CPTC Complex, Beausejour, MB, Canada	TRL Cup (Final)