

Installation Instructions Spacer Kit for Sidewinder Turret™

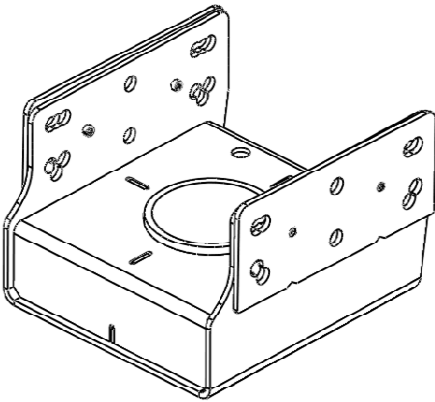

DEALER/INSTALLER:

(1) Provide this Manual to end user

END USER:

- (1) Read and follow this Manual for Sidewinder Turret Installation.
- (2) Save this Manual for Future Reference.
- (3) For Sidewinder Arm Installations, Refer to there Installation Manuals.
- (4) Pass on copies of Manual to any other users or owner.

Part Number:
61301

Turret Shown w/Spacer Kit Installed

Note: These Instructions Are Only For Installation Of Turret Into Wing Sets.
You Should Refer To The Installation Instructions For Your Sidewinder Arm.

Equipment Required:

Fastener Kit: 61301F

Drill Bits: Not Required

Torque Wrench

Hammer

Do Not Exceed Lower of Towing Vehicle Manufacturer's Rating,
Trailer Manufacturer's Rating or

Max Gross Trailer WT (LB)	Max Pin WT (LB)
19,500 LB	3,900 LB

①	Qty. (1)	Turret 61300 (Formally ST100 & ST200)
②	Qty. (2)	Spacer Plate
③	Qty. (4)	Roll Pin

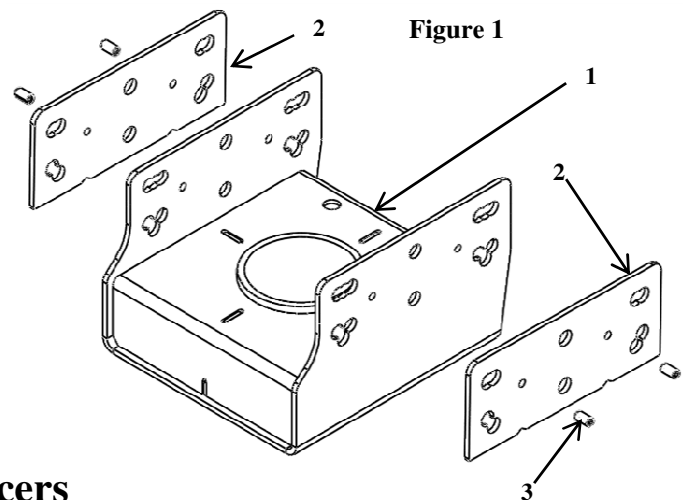

Figure 1

INDEX

- | | |
|-------------------------------------|------|
| 1. ASSEMBLING SPACERS ON TURRET | P. 1 |
| 2. GUIDELINES FOR MATCHING WING SET | P. 2 |
| 3. 5 YEAR LIMITED WARRANTY | P. 3 |

Assembling Spacers

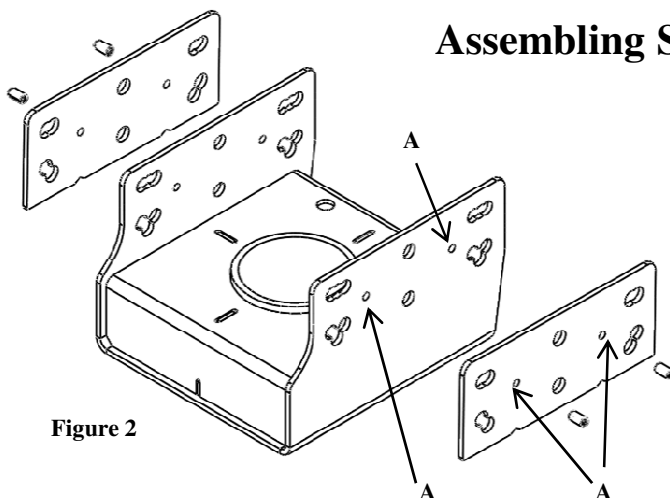

Figure 2

- Position spacer plate (2) onto side of turret (1). Align holes (A) on spacer plate and turret. Install roll pin (3) into hole. Tap with hammer until flush with surface on the outside of turret.
- * You must install one spacer plate on each side of turret. Spacer plates can be used on either side.
 - * Note: There are two notches in the spacer plates they must be at the bottom.

Installation Instructions

Sidewinder Turret™

Matching Wing Sets

Figure 3

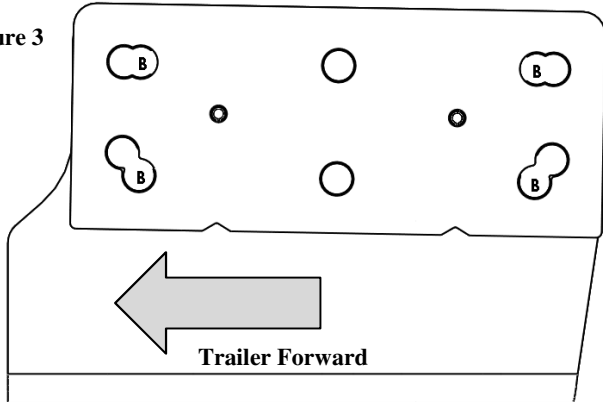

For Wing Set Make and Model Numbers:

Lippert 1716

Lippert 1116

Lippert 0115

Use The Bolt Hole Locations Noted By The "B"

The pattern is a 8.75" horizontal & a 2.5" vertical

Note: Shown w/Spacer Kit 61301 Installed

Figure 4

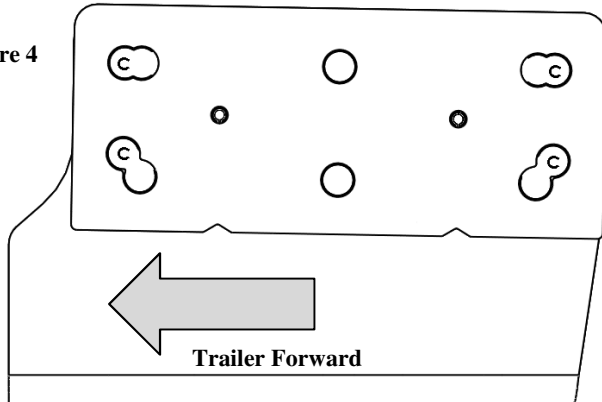

For Wing Set Make and Model Numbers:

Fabex PB-500 Series

Note: For the 500 series only one row is needed.

(2 Bolts per Side)

Fabex PB-700 Series

Use The Bolt Hole Locations Noted By The "C"

The pattern is a 9.5" horizontal & a 2" vertical

Note: Shown w/Spacer Kit 61301 Installed

Typical Bolting

Hardware Kit Contains: (8) 5/8-11x2 Gr.8 Bolts / (8) 5/8-11 Gr.8 Nuts / (8) 5/8 HD Flat Washers / (8) 5/8 Conical Lock Washers

Bolts & Flat Washers Are Installed From The Outside, Conical Lock Washers and Nuts On the Inside.

Torque All To 210 ft. lbs.

