

# Installation Instructions

## 5<sup>th</sup> AIRBORNE

Part Numbers:

ALL 5AB-XXXX

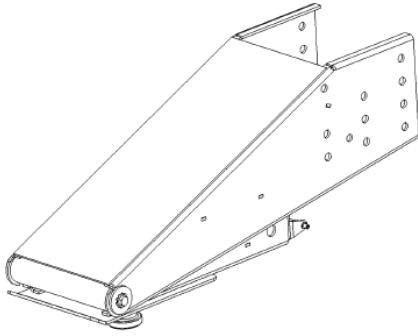

### PIN BOX SHOWN ASSEMBLED

#### Equipment Required:

Wrenches: 15/16", TORQUE WRENCH

#### DEALER/INSTALLER:

(1) Provide this Manual to end user

#### END USER:

(1) Read and follow this Manual every time you use this product.

(2) Save this Manual for Future Reference.

(3) Pass on copies of Manual to any other users or owner.

**Do Not Exceed Lower of Towing Vehicle Manufacturer's Rating,  
Trailer Manufacturer's Rating or**

Max Gross Trailer WT (LB)	Max Pin WT (LB)
<b>21,000 LB</b>	<b>4,200 LB</b>

①	Qty. (1)	Air Spring
②	Qty. (1)	Shock
③	Qty. (2)	Shock Bolt (1/2-13 X 3.75")
④	Qty. (2)	1/2-13 Nylon Lock Nut
⑤	Qty. (1)	Air Fill Line
⑥	Qty. (2)	3/8" Split Lock Washer
⑦	Qty. (2)	3/8-16 X 1 GR5 Bolt
⑧	Qty. (2)	Bushing
⑨	Qty. (2)	Pivot Shaft
⑩	Qty. (2)	Special Washer
⑪	Qty. (1)	Star Washer
⑫	Qty. (1)	1/2-20 X 1 GR 5 Bolt

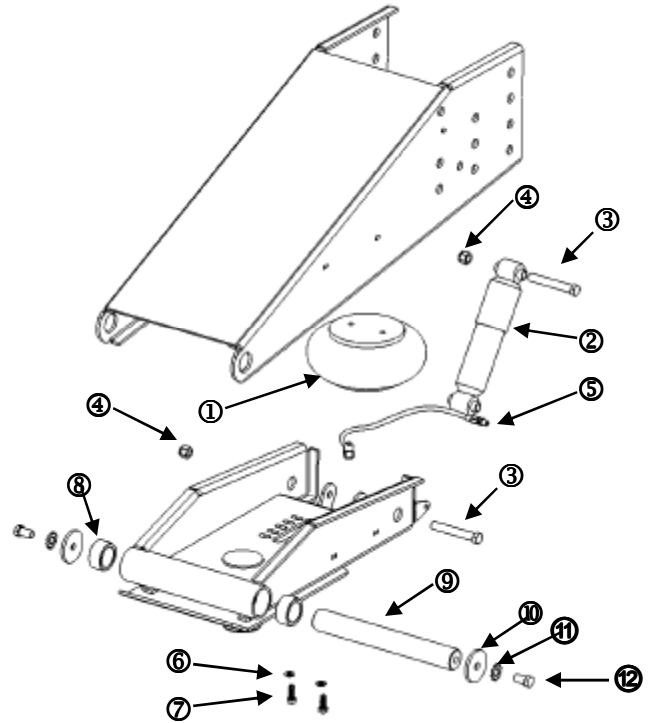

Figure 1

#### **⚠ WARNING:**

**Failure to follow all of these instructions may result in death or serious injury!**

# Installation Instructions

## 5<sup>th</sup> AIRBORNE

### GUIDELINES FOR MATCHING TOW VEHICLE AND TRAILER

#### **WARNING:**

**Failure to check and follow tow ratings could result in tow vehicle damage or truck and trailer separation while towing.**

- Trailer and its contents together must not exceed truck, hitch and/or trailer tow ratings.
- Towing vehicle must have a manufacturer's rated towing capacity equal to or greater than the gross trailer weight (dry weight of the trailer plus payload of the trailer). (See Fig. 2)
- Gross weight of trailer must not exceed 21,000 pounds for this product.
- King pin weight must not exceed 4,200 pounds (See Fig. 3). If in doubt have king pin weight measured by qualified facility.

#### 1. Check Tow Ratings:

Vehicle Tow Rating: \_\_\_\_\_.

5<sup>th</sup> Airborne Pin Box Rating: **21,000 lbs.**

Gross Trailer Weight (Figure 2): \_\_\_\_\_.

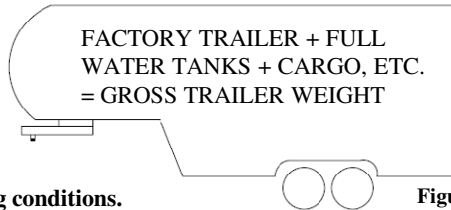

Figure 2

**\*Trailer weight should be the lowest of these recorded ratings for safe towing conditions.**

#### 2. The 5<sup>th</sup> Airborne pin box is designed for a maximum of 20% Gross Trailer Weight on the pin (Pin Weight). See Fig. 3

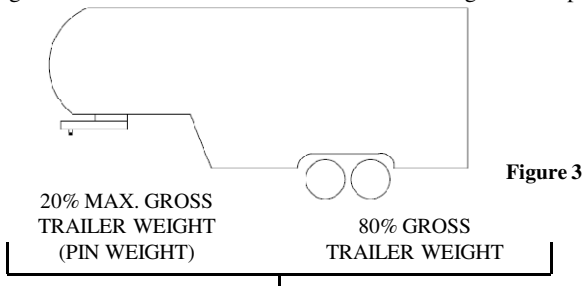

Figure 3

#### 3. The Height of the hitch and pin box should be adjusted so the trailer is approximately level as it is towed. Allow approximately 6 in. clearance between the top of the bed and the underside of the front of the trailer for pitch and yaw of the trailer (See Figure 6). For off-road use allow more clearance between pickup walls and trailer.

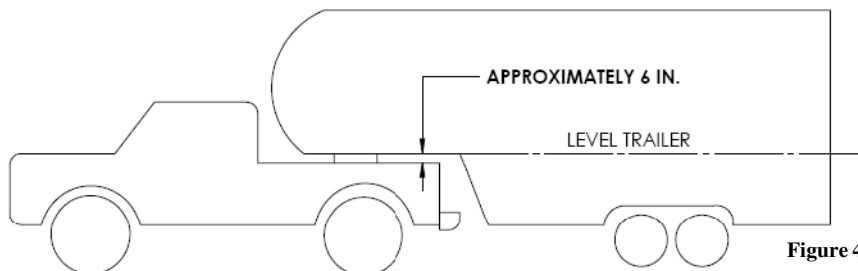

Figure 4

#### **WARNING:**

**Avoid putting any part of your body under the trailer or between the truck and trailer. Unexpected or accidental movement of the truck or the trailer can cause serious injury or death**

•If you must place any part of your body under the trailer or between the truck and trailer you **MUST** perform **ALL** of the following steps:

- Check that the truck transmission is in park
- Check that the emergency brake is set
- Block in front of and behind all trailer tires
- Check that the trailer landing gear are resting on firm ground

# Installation Instructions

## 5<sup>th</sup> AIRBORNE

### ASSEMBLY INSTRUCTIONS

1. Before removing the original pin box, take note of the number of bolts used attaching the existing pin box to the mounting wing set. Cequent Performance Products recommends using at least the same number of bolts upon installation as removed from the original pin box. (Figure 5)

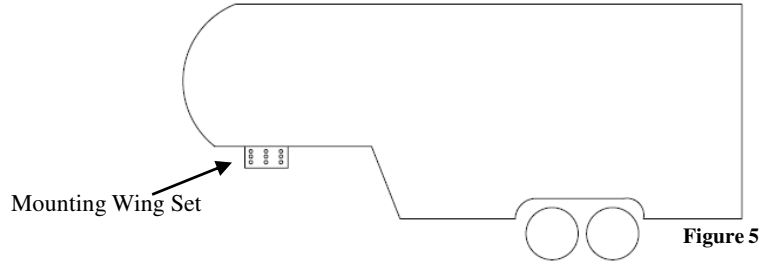

2. Remove the existing pin box, taking care to remove any necessary wiring and/or break away switch if attached to the pin box. (If removed, the break away switch must be reinstalled after installation is complete)
3. Install the 5<sup>th</sup> Airborne inside the mounting wings (Figure 6), with exception to tube style pin boxes. Cequent Performance Products recommends replacing the mounting bolts, nuts, and lock washers with the same size & grade as the bolts removed from the original pin box. Torque all bolts to the proper value listed in table 1.

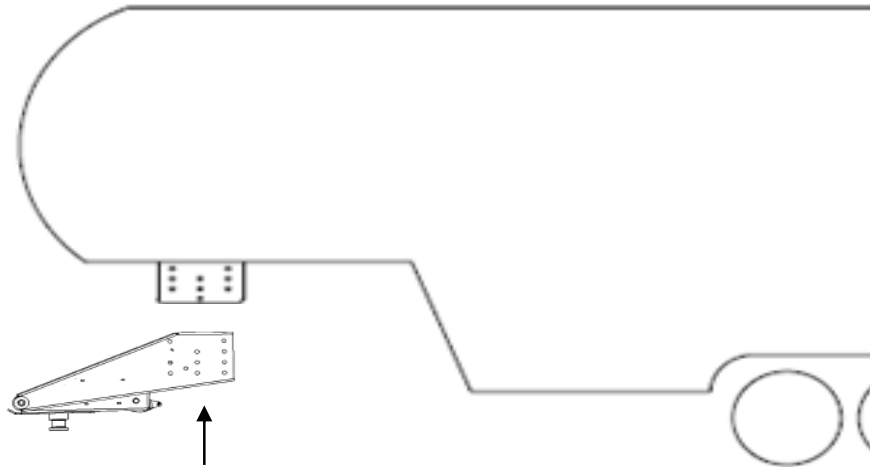

*Note: Installing the front bolts first may ease alignment.*

**⚠️ WARNING:** The 5<sup>th</sup> Airborne pin box is heavy, take care to maintain adequate support under the 5<sup>th</sup> Airborne arm until at least 2 bolts per side are installed. Failure to do so may result in death or serious injury.

Bolt Diameter	Torque
1/2" Bolts GR5	90 ft-lbs
5/8" Bolts GR5	150 ft-lbs
3/4" Bolts GR5	275 ft-lbs

Table 1

# Installation Instructions

## 5<sup>th</sup> AIRBORNE

### ADJUSTING THE AIR SPRING

1. Perform the hitching procedure following the proper hitching procedure according to the manual for your fifth wheel Hitch.
2. Add air to the air spring at the valve shown in figure 7. Continue adding air until the skid plate is level (on level ground) see figure 8. (Most units have the fill level label on the side of the lower jaw of the pin box, some will have the fill level label on the shock.)

*The fill level line is a good reference for setting air pressure in the spring, if more performance is desired the air bag position and pressure can be adjusted to suite your preference. The air spring position can be adjusted by removing the mounting bolts shown in figure 7 and moving the bag as indicated per your loading condition. A good starting point for pressure setting is 80-100 psi. (Do Not Exceed 120 psi). If the ride is too soft, add more pressure. If the ride is harsh, remove pressure. If the pressure adjustment cannot maintain a satisfactory ride, reposition the air spring according to figure 7.*

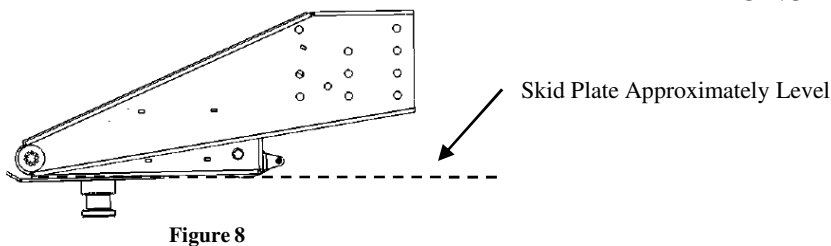
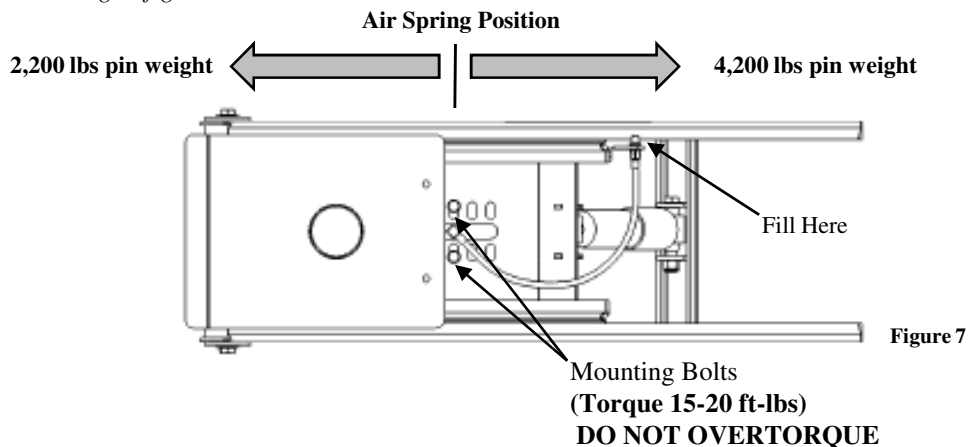

### BEFORE EACH TRIP:

1. CHECK YOUR EQUIPMENT: Check that condition of all of your towing equipment and keep it in top condition.
2. Check to see that all bolts are properly tightened.
4. Check that the airbag pressure is set for your coach. (The skid plate should be near level when parked on level ground)

### MAINTENANCE:

1. For ease of hookup; frequently lubricate the skid plate surface and the back side of the king pin.
2. Keep pin-box hitch painted to prevent rust and maintain a good appearance. (Do Not paint over labels)