

Ford '04-14 , F-150, 5.5', 6', & 8' BEDS : For 30035 Kit

⚠ CAUTION! ⚠

Read pages of the 30035 instructions before starting installation. Failure to do so could result in significant vehicle damage!

IMPORTANT NOTES FOR THIS INSTALLATION:

1. Do not drill through both walls of frame. Drill only through wall of frame to which bracket is mounted.
2. Find parallel rows of bed sill spot welds in bed of truck. No drilling should be done in the ~4" between parallel rows of spot welds where the bed sill sits.

3. Remove jounce block from bottom of frame on both sides.

4. When brackets are in place one of the front 2 holes should line up with a hole in the frame. A hole will need to be drilled in the frame at the rearward bracket hole.

5. Pull carriage bolts with bolt plates (using supplied pull wires) through the hole in the bottom of frame (where the jounce block was removed) and through the rear hole in each bracket. On the forward brackets a carriage bolt, bolt plate and a 1" washer should be pulled through the forward hole, rearward brackets a carriage bolt, bolt plate and 13/16" washer.

6. Replace the jounce block.

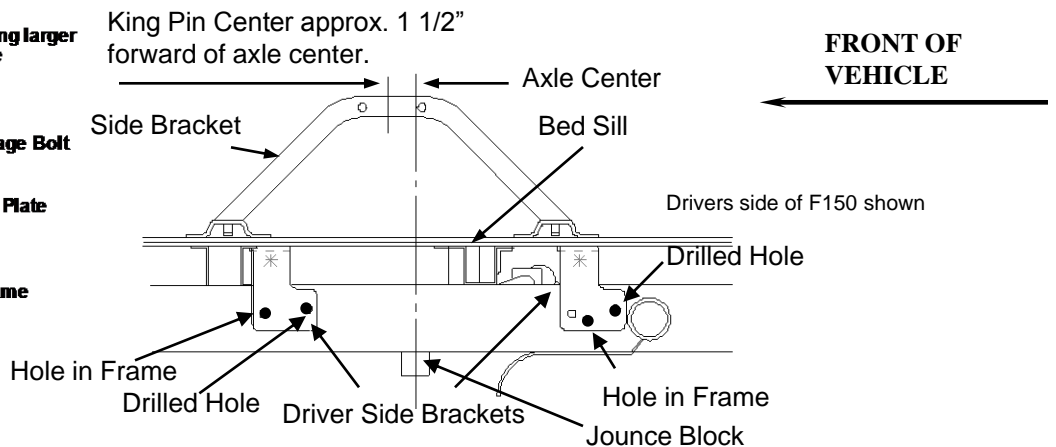
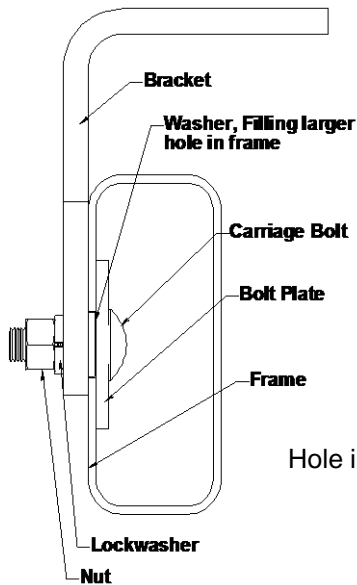
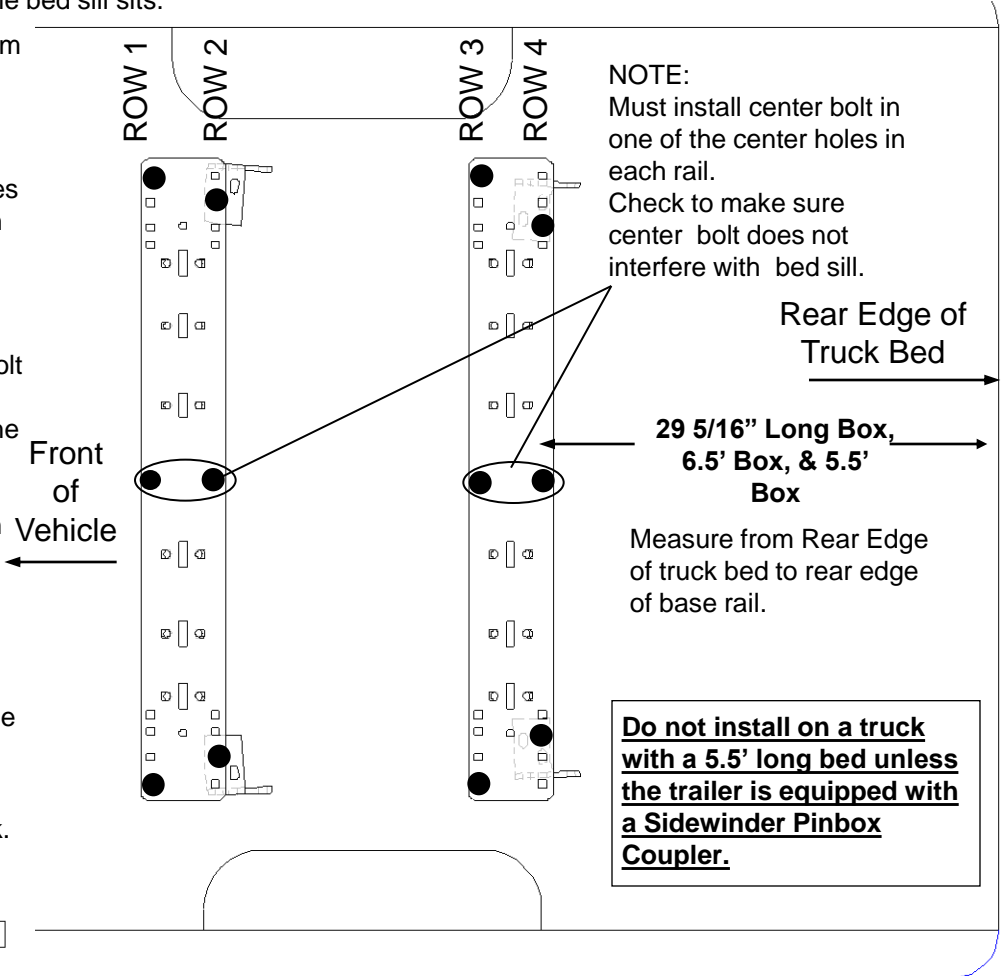

Ford '04-14, F-150, 5.5', 6', & 8' BEDS : For 30095 kit

⚠ CAUTION! ⚠

Read pages 2-3 of the 30095 instructions before starting installation. Failure to do so could result in significant vehicle damage!

IMPORTANT NOTES FOR THIS INSTALLATION:

1. Do not drill through both walls of frame. Drill only through wall of frame to which bracket is mounted.
2. Find parallel rows of bed sill spot welds in bed of truck. No drilling should be done in the ~4" between parallel rows of spot welds where the bed sill sits.

3. Remove jounce block from bottom of frame on both sides.

4. When brackets are in place one of the front 2 holes should line up with a hole in the frame. A hole will need to be drilled in the frame at the rearward bracket hole.

5. Pull carriage bolts with bolt plates (using supplied pull wires) through the hole in the bottom of frame (where the jounce block was removed) and through the rear hole in each bracket. On the forward brackets a carriage bolt, bolt plate and a 1" washer should be pulled through the forward hole, rearward brackets a carriage bolt, bolt plate and 13/16" washer.

6. Replace the jounce block.

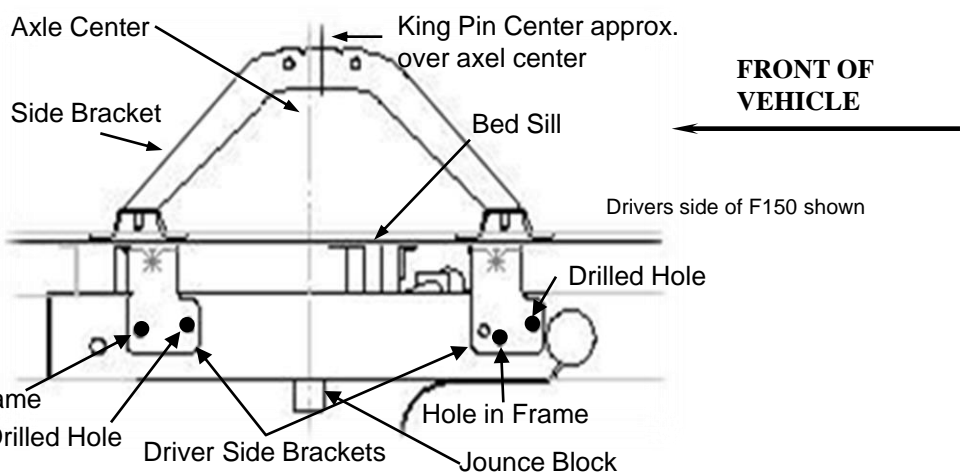
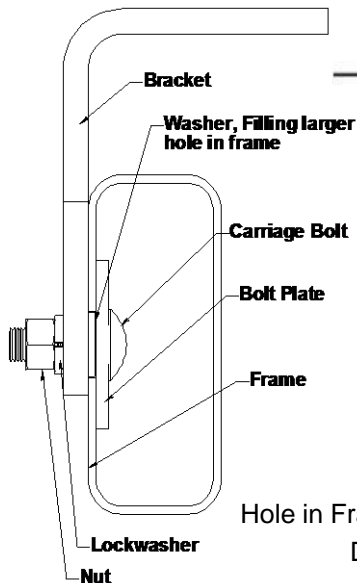
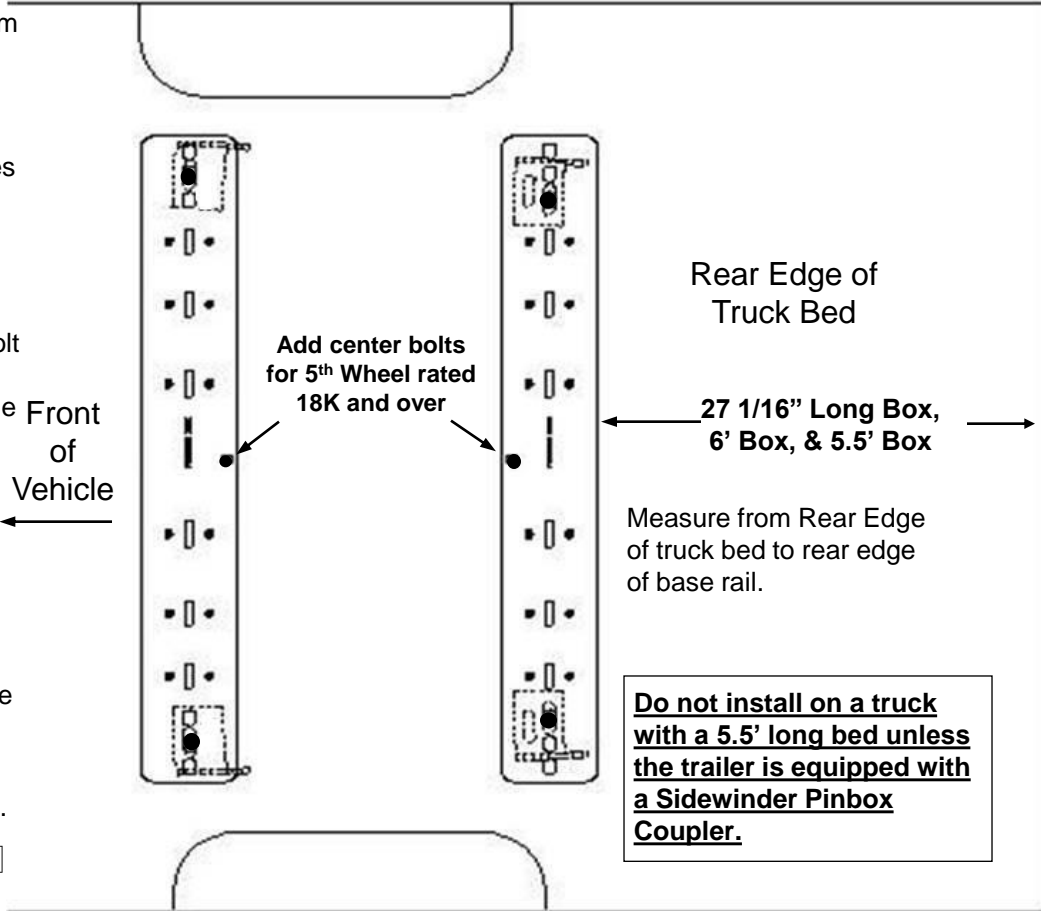

⚠ CAUTION! ⚠

Check for obstructions before drilling. Failure to do so could result in damaged fuel or brake lines, structural members, etc. CEQUENT TOWING PRODUCTS does its best to communicate tow vehicle manufacturer changes; however, it is ultimately the responsibility of the installer to prevent damage due to installation.