

## IMPORTANT NOTES FOR THIS INSTALLATION:

1. Use the 58309 service kit together with the 30035 mounting kit. Read p. 1-3 of the 30035 instruction for general information.
2. The mounting holes for Row 3 go through the inside of the bed sill. Make sure it lines up correctly. Drill through the bed and the top of the frame on both sides. For the Row 4 passenger side attachment, drill through the bed and the top of the frame as well.
3. The rear rail on the passenger side is secured directly to the frame with 3" carriage bolts provided in the 58309 kit. For the Row 3 attachment 2, a tube spacer should be placed inside the bed sill on top of the frame and under the bottom of the bed. Line up the spacer with the drilled hole before inserting the carriage bolt. Repeat for both sides. See **Detail Inside Frame**.

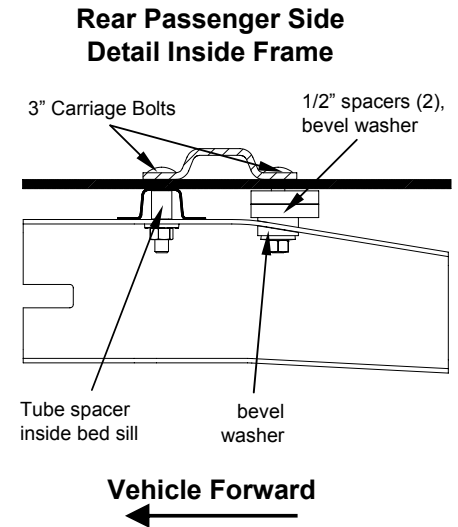

4. For the Row 4 passenger side attachment, stack two 1/2" spacers and a bevel washer, provided in the 58309 kit, to fill the gap between the bed and the frame. Use another bevel washer, conical toothed washer, and hex nut to fasten the 3" carriage bolt in place. See **Detail Inside Frame**.
5. Install the long brackets on the front rail and the short bracket on the rear rail driver side using the 1-3/4" carriage bolts provided in the 58309 kit. All other attachments to the bed use 2" carriage bolts from the 30035 kit.

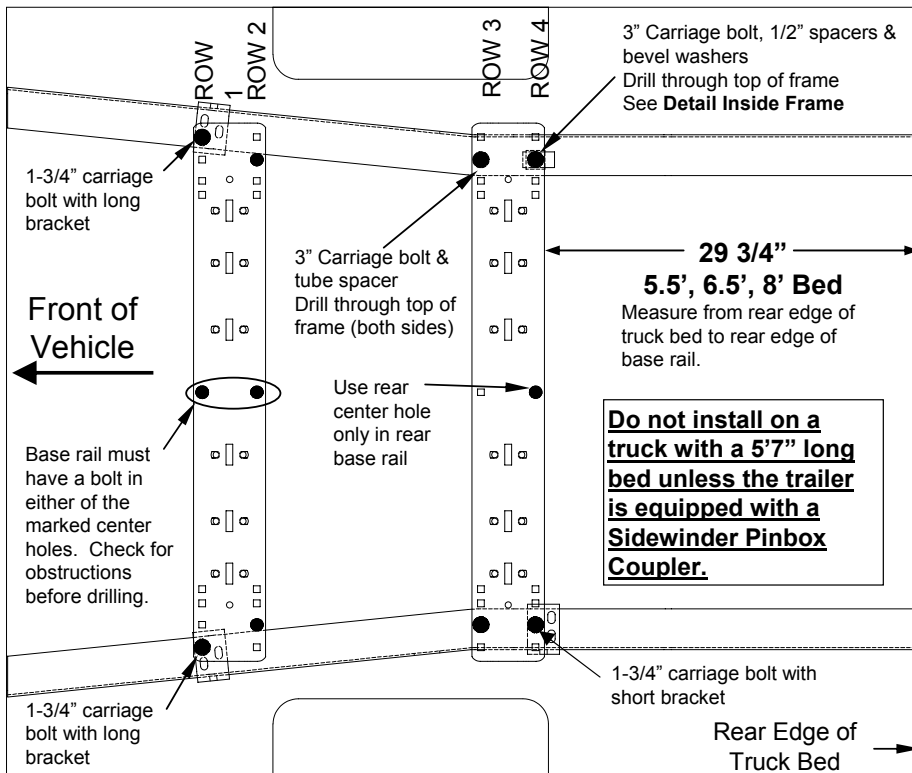