

**WARNING:** Under no circumstances do we recommend exceeding the towing vehicle manufacturers recommended vehicle towing capacity.

## READ ALL INSTRUCTIONS BEFORE STARTING THE INSTALLATION

REESE® Custom Quick Install mounting brackets only include the hardware to attach the custom brackets to the frame.

### 10 BOLT INSTALLATION

All Fasteners  
Typical Both Sides

**Equipment Required:**  
**Fastener Kit:** 56009F  
**Wrenches:** 3/4", 18mm  
**Drill Bits:** 1/8", 9/16" & 1 1/4" Hole saw  
**Other Tools:** Center Punch, Measuring Tape

**Vehicle Forward** ←

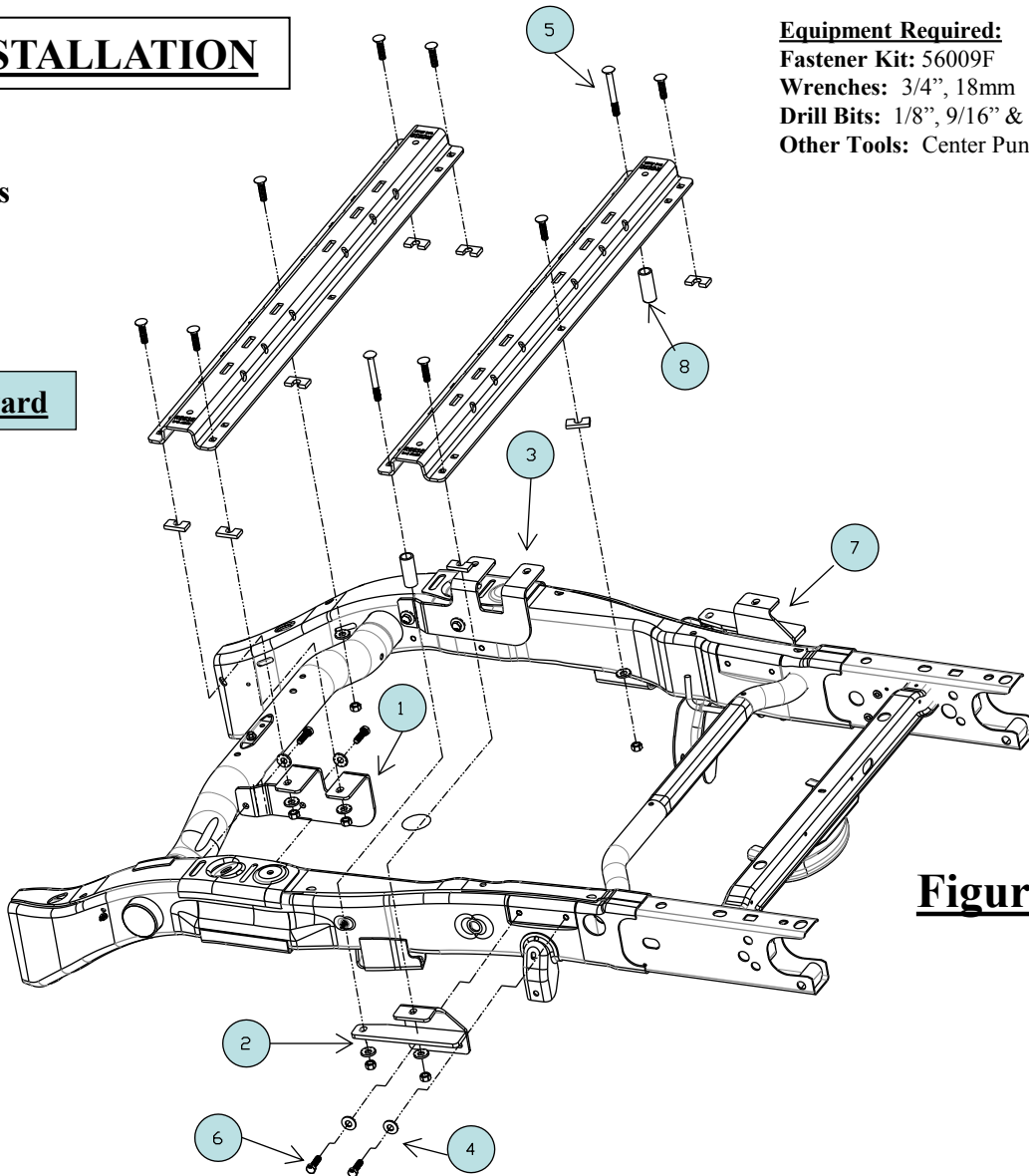

**Figure 1**

ITEM	DESCRIPTION	QUANTITY	ITEM	DESCRIPTION	QUANTITY
1	DRIVER SIDE FRONT BRACKET	1	7	PASSENGER SIDE REAR BRACKET	1
2	DRIVER SIDE REAR BRACKET	1	8	BUSHING 2.773"	2
3	PASSAGER SIDE FRONT BRACKET	1			
4	CONICAL WASHER 1/2"	8			
5	BOLT, 1/2"-13X4.500" GR8	2			
6	BOLT, M12 - 40MM - 1.5" 10.9	8			

**All of the fasteners listed to the left are supplied with this kit, all other mentioned fasteners are supplied with part number 30153.**

- **Do not install mounting rails over plastic bed liners. Plastic bed liners must be cut out of the way to provide metal to metal contact. Mounting rails may be installed on spray in liners.**
- **Use only bolts, nuts, and washers supplied to install this kit. All bolts and nuts are Grade 8 unless otherwise specified.**
- **These instructions are guidelines only, actual installation is the responsibility of the installer and the owner. Always measure truck and trailer before installing hitch to be sure that there is clearance at the cab and at the bumper to allow for turns.**

## **Installation Instructions**

1. Lower and remove spare tire if extra room is needed. Remove inner plastic wheel well liner to allow access to frame.
2. Detach the electrical wire loom and brake lines from the inside driver side of the frame.
3. Place the rear mounting rail in the box of the truck, using your tape measure, center the rail between the weld seams on the length of the truck box floor and the proper distance from the rear edge of the truck box as shown in Figure 2.  
**Note:** It is critical that rail is centered side to side on the truck bed.
4. Mark and center punch the holes as shown in Figure 2. Move the rail out of the way and drill each position with a 1/8" drill bit.
5. Temporarily position the frame bracket on the outside of the frame and check that the 1/8" drilled holes align with the slots of the frame bracket. Remove the frame bracket from the vehicle.
6. Enlarge the 1/8" drilled holes to 9/16".
7. Loosely install the frame brackets by attaching the bolts (6), conical washers (4) and front (1) (3) and rear brackets (2) (7). (See Figure 1)
8. Enlarge row 3 holes in bed only to 1 1/4". (See Figure 2)
9. Install bushing (8) in to the 1 1/4" hole. Move rear mounting rail into position. Install the 1/2"-13 x 4 1/2" bolts (5) through rail, bushing (8) and rear brackets (2) (7). Attach 1/2" conical washers and 1/2" nut per the illustrations and tighten snug to keep the mounting rail from moving.
10. Place the unassembled 5th wheel saddles/slider/goose into the already installed mounting rail. Position the front mounting rail with the saddles/slider/goose by inserting the tabs into the mounting rail and pushing the mounting rail tight towards the other mounting rail. Ensure that the mounting rail is centered between the weld seams on the length of the truck box floor. This will position the mounting rail in the correct location and ensure that the 5th wheel will have a snug fit to the truck. **NOTE:** If more than one hitch product will be used with the rails then both should be used at the same time to align the second rail. This will ensure that one product does not compromise the fit of the other.
11. Repeat steps 4 through 6.
12. Move the mounting rail into position. Install the 1/2"-13 x 2 1/2" carriage bolts with the U-shaped spacer to be located in the corrugation between the box and the mounting rail or between the box and front bracket (1) (3). (**Note the U-shaped spacer is to eliminate crushing bed corrugation.**) Attach with spacers and nuts as per the illustrations and tighten snug to keep the mounting rail from moving.
13. After fully installing the 56009 custom attachment brackets, tighten the fasteners in the following sequence. **Note: Torque all 1/2" hardware to 110 ft-lbs and all M12 hardware to 92 ft-lbs (125 N\*M). First torque the mounting rails to the frame brackets and then torque the frame brackets to the truck frame.**
14. Replace inner plastic wheel well liner to body, if removed reinstall spare tire.

# DIMENSIONS SPECIFIC FOR RAIL KIT 30153

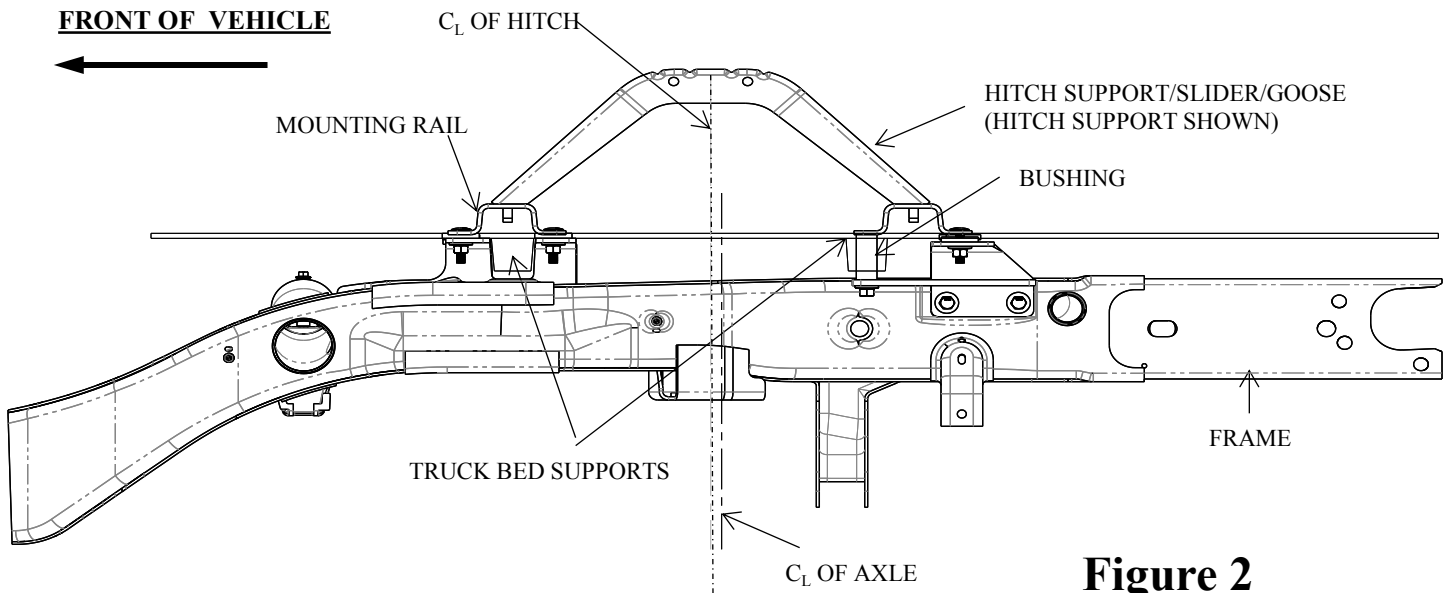
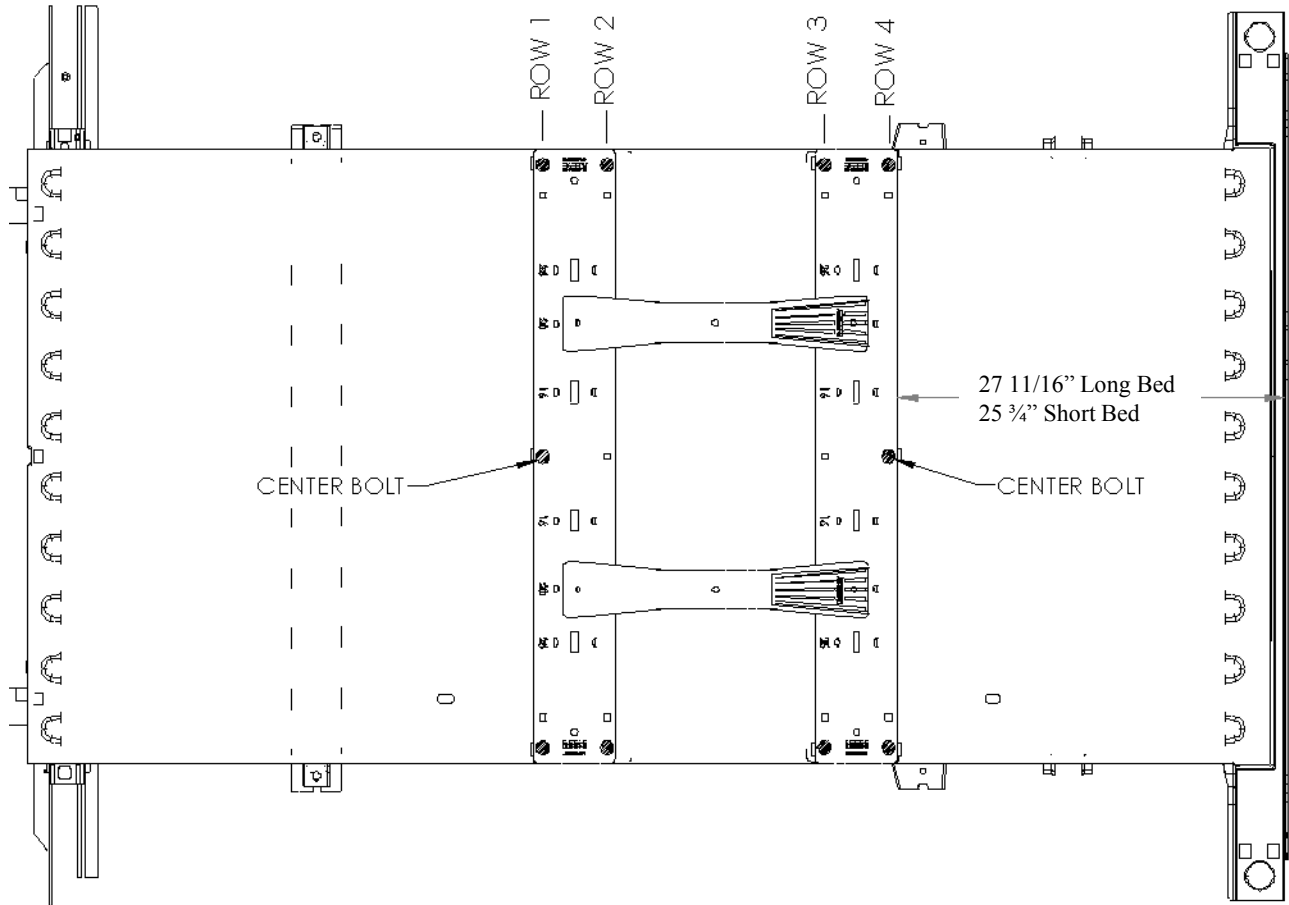

**Figure 2**