

ASSEMBLY INSTRUCTIONS

Reese® Elite™ Pop-In™ Ball and Safety Chain Attachment

DEALER/INSTALLER:

- (1) Provide this Manual to end user.
- (2) Physically demonstrate procedures in this Manual to end user.
- (3) Have end user demonstrate that he/she understands procedures.

END USER:

- (1) Read and follow this Manual every time you use Hitch.
- (2) Save this Manual for future reference.
- (3) Pass on copies of Manual to any other user or owner of Hitch.

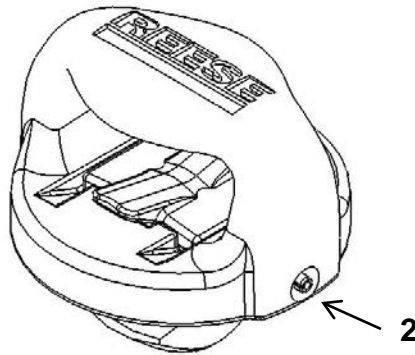
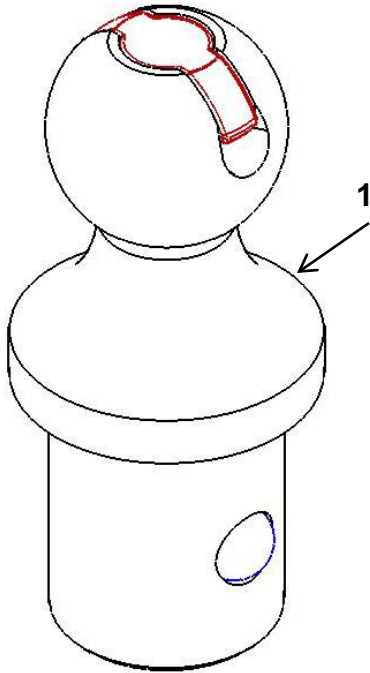

Figure 1

PART

QTY.

- | | |
|-----------------------------|---|
| 1. POP – IN™ GOOSENECK BALL | 1 |
| 2. SAFETY CHAIN ATTACHMENT | 2 |
| 3. GOOSENECK COVER | 1 |
| 4. STORAGE BAG | 1 |

REESE® Elite™ Series Pop-In™ Gooseneck Ball and Safety Chain Attachments

1. Check all the boxes for all the components listed in **Figure 1** and become familiar with component terminology.
2. To install Pop-In™ Gooseneck ball - Lift handle in center of the ball and rotate 90 degrees (see figure 2). Insert Gooseneck ball assembly in the receiver tube in the bed of the truck with the ball bearings oriented side to side of the truck bed, Turn the center handle 90 degrees so that it drops in the slit in the top of the ball. If the center handle does not retract fully, rotate the ball until the handle seats itself in the slot (see figure 3).
3. To install the Safety Chain Attachment – place the Safety Chain Attachment on top of the q-turn pucks (see Figure 6 below). Rotate the Safety Chain Attachment 90 degrees until the center lock drops into place (see Figure 4). To remove the Safety Chain Attachment lift the center lock and rotate the complete assembly 90 degrees (see Figure 5).
4. When not using the Pop-In™ Gooseneck ball place it in the supplied bag (4) and put the gooseneck cover (3) in its place. See Figure 7 on the next page.

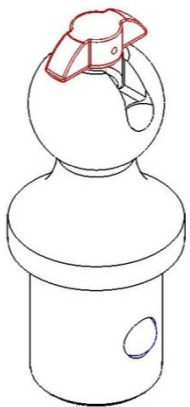
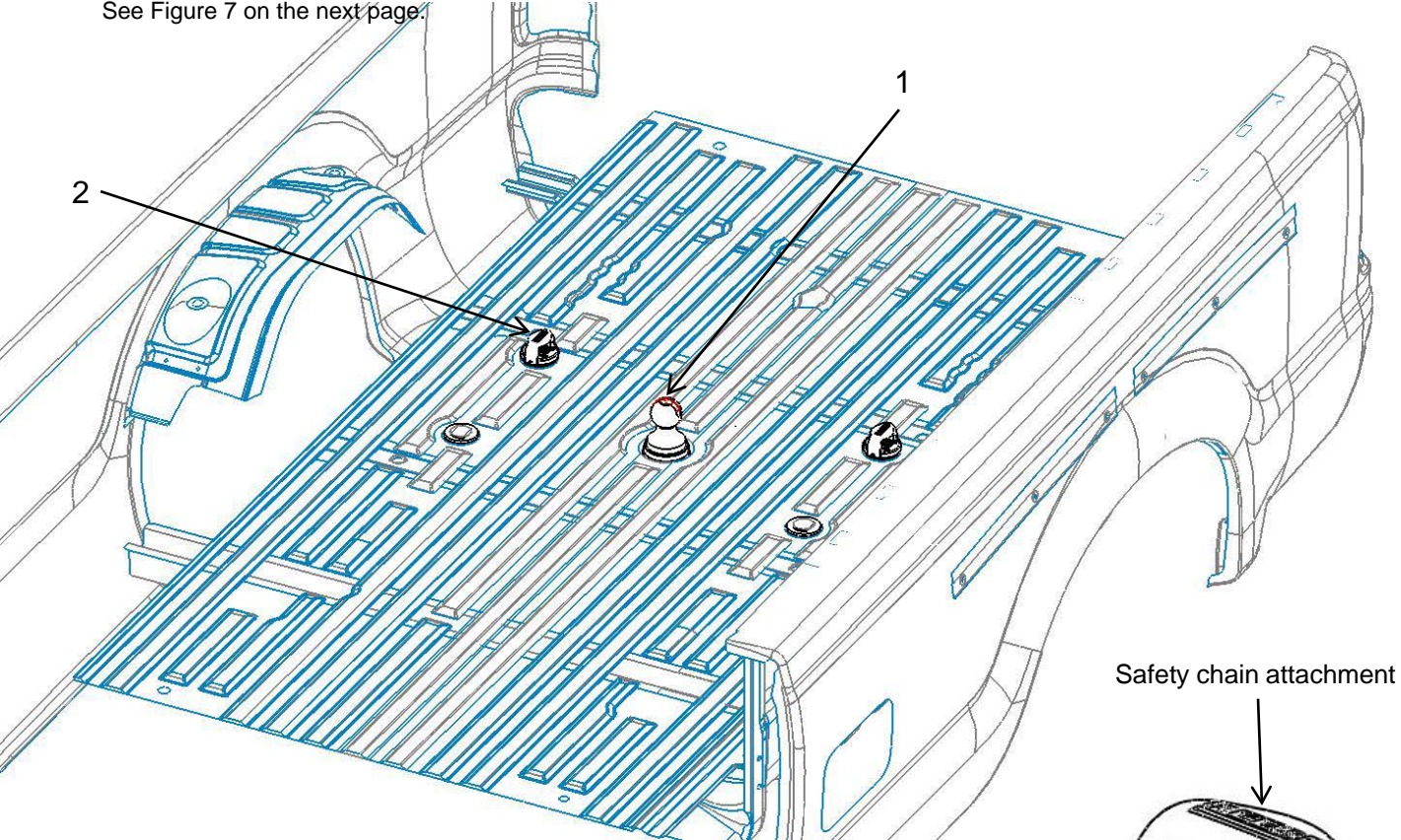

Figure 2 – Unlocked

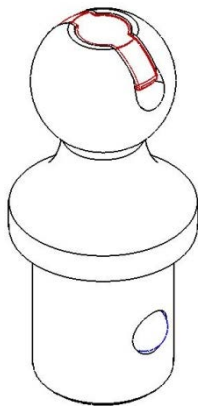

Figure 3 - Locked

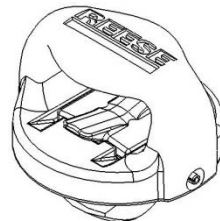

Figure 4 - Locked

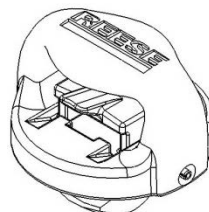

Figure 5 - Unlocked

Safety chain attachment

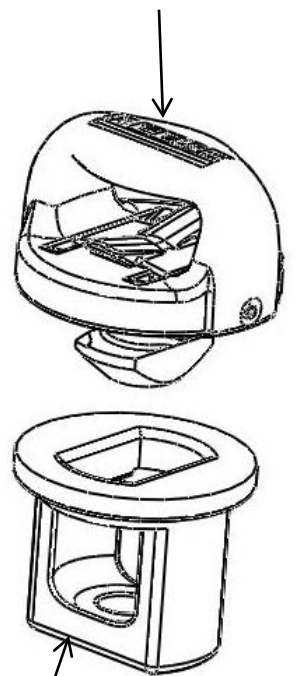
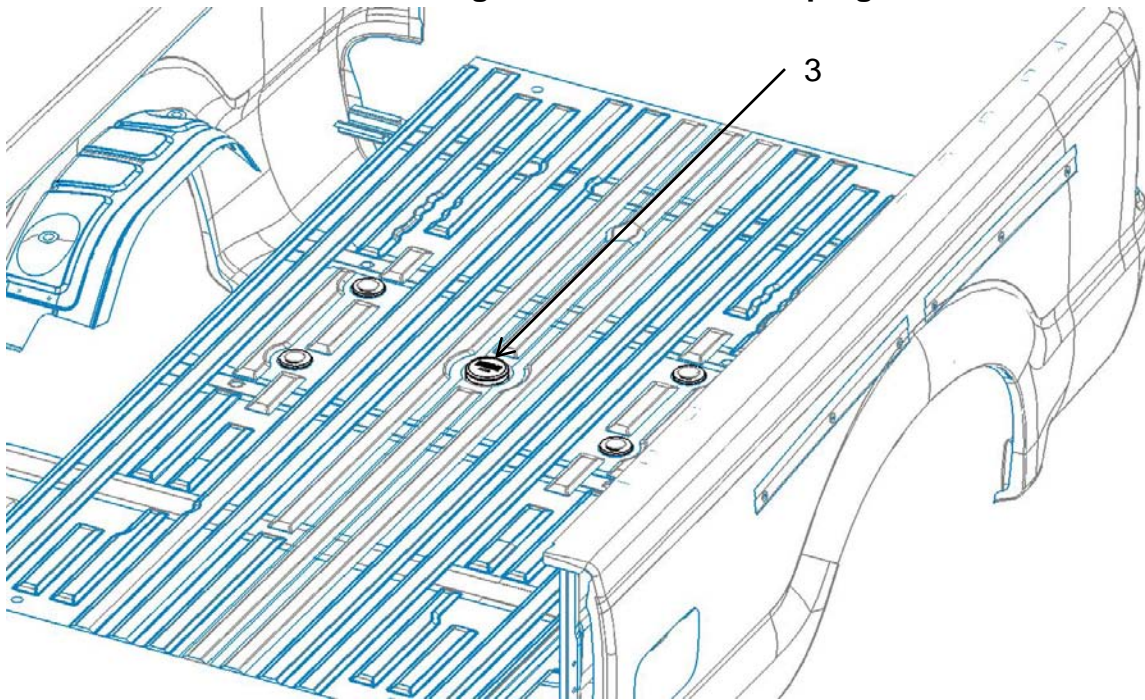

Figure 6

Q-turn puck mounted below truck bed

Figure 7 – Center cover plug installed



REESE® Elite™ Series **Gooseneck HITCH SYSTEM**
IMPORTANT INFORMATION ON TOWING

TOWING EQUIPMENT OWNERS: Make sure all operators of your equipment read and understand this information before towing. Save for reference. This will help you properly use and maintain your towing equipment. Refer to owner's manuals for your tow vehicle, trailer and other parts of your towing system. Learn the capabilities and limitations of each part. **GROSS TRAILER WEIGHT** and **VERTICAL LOAD** are the two most important items to consider. **THESE WEIGHTS MUST NEVER EXCEED THE LOWEST RATING OF ANY PART OF YOUR TOWING SYSTEM.** **GROSS TRAILER WEIGHT** is the weight of the trailer plus cargo. Measure **GROSS TRAILER WEIGHT** by putting the fully loaded trailer on a vehicle scale. **VERTICAL LOAD** is the downward force exerted on the ball by the trailer coupler. Use a vehicle scale to measure **VERTICAL LOAD** with the fully loaded trailer on a level surface and the coupler at normal towing height.

TRAILER COUPLERS

The coupler should be smooth, clean and lightly lubricated. Adjust per coupler manufacturer's instructions.

SAFETY CHAINS

Connect safety chains properly **EVERY TIME YOU TOW**. Attach securely through the chain loops provided so they can not bounce loose. Leave only enough slack to permit full turning. Too much slack may prevent chains from maintaining control if other connections separate.

TRAILER LIGHTS, TURN SIGNALS, ELECTRIC AND BREAKAWAY SWITCH CONNECTIONS

Make these safety-critical connections **EVERY TIME YOU TOW**, no matter how short the trip. Check operation, including electric brake manual control, before getting on the road.

TIRE INFLATION

Check often. Follow tow vehicle and trailer manufacturer's recommendations.

CHECK YOUR EQUIPMENT/REPLACE WORN PARTS

Check ball, coupler, chains, and all other connections **EVERY TIME YOU TOW**. Re-check at fuel and rest stops.

NO PASSENGERS IN TRAILER!

Never allow people in the trailer while towing, under any circumstances.

TRAILER LOADING

Place heavy objects on the floor ahead of the axle. Balance the load side-to-side. Secure it to prevent shifting. **NEVER** load the trailer rear heavy. **LOAD THE TRAILER HEAVIER IN THE FRONT, BUT NOT GREATER THAN TONGUE WEIGHT RATING OF THE HITCH.**

DRIVING

The additional weight of a trailer affects acceleration, braking and handling. Allow extra time for passing, stopping, and changing lanes. A gooseneck trailer requires a large turning radius as the trailer tracks to the inside of turns. Severe bumps can damage your towing vehicle, hitch and trailer. Drive slowly on rough roads. **STOP AND MAKE A THOROUGH INSPECTION IF ANY PART OF YOUR TOWING SYSTEM STRIKES THE ROAD. CORRECT ANY PROBLEMS BEFORE RESUMING TRAVEL.**

WARNING

DO NOT MODIFY. Do not tow one trailer behind another, which may cause loss of control. Failure to heed warnings and follow instructions may result in serious personal injury or death, vehicle crash, and/or property damage.