



INSTALLATION INSTRUCTIONS MOUNTING KIT FOR ELITE SERIES

DEALER/INSTALLER:

- (1) Provide this Manual to end user.

END USER:

- (1) Save this Manual for future reference.
- (2) Pass on copies of Manual to any other user or owner of Hitch.

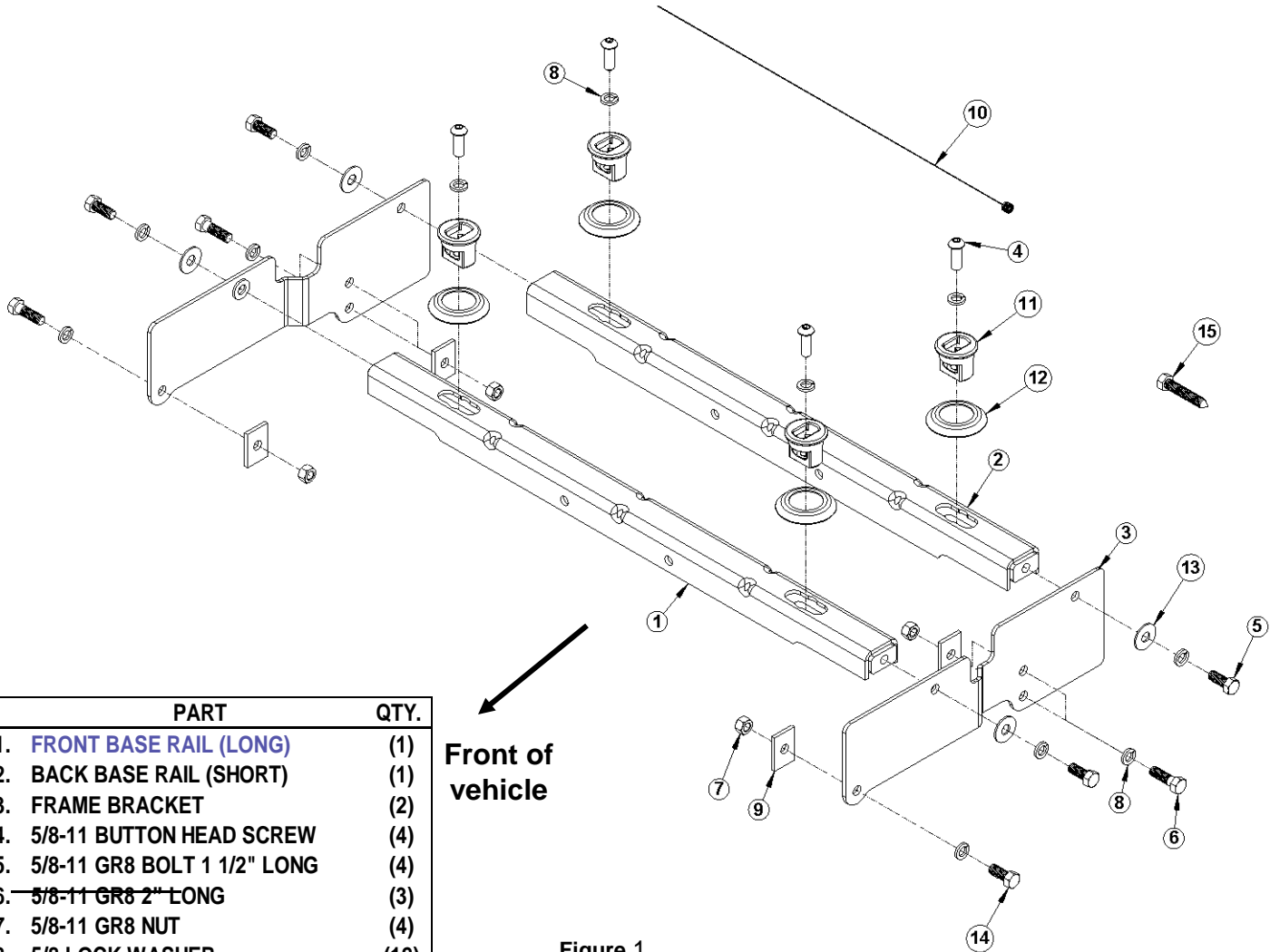

Figure 1

PART	QTY.
1. FRONT BASE RAIL (LONG)	(1)
2. BACK BASE RAIL (SHORT)	(1)
3. FRAME BRACKET	(2)
4. 5/8-11 BUTTON HEAD SCREW	(4)
5. 5/8-11 GR8 BOLT 1 1/2" LONG	(4)
6. 5/8-11 GR8 2" LONG	(3)
7. 5/8-11 GR8 NUT	(4)
8. 5/8 LOCK WASHER	(12)
9. SPACER	(4)
10. PULL WIRE	(1)
11. PUCK	(4)
12. TRIM RING	(4)
13. 5/8 FLAT WASHER	(4)
14. 5/8-11 GR8 BOLT 1 1/2" LONG W/ LOC-TITE PATCH	(1)
15. 5/8-11 X 3 1/2" WITH POINT	(1)

⚠ WARNING:

Failure to follow all of these instructions may result in death or serious injury!

GUIDELINES FOR MATCHING HITCH TRUCK AND TRAILER

⚠ WARNING:

Failure to check and follow tow ratings could result in tow vehicle damage or truck and trailer separation while towing.

- Trailer and its contents together must not exceed truck, hitch and/or trailer tow ratings.
- Towing vehicle must have a manufacturer's rated towing capacity equal to or greater than the gross trailer weight (dry weight of the trailer plus payload of the trailer). (Figure 2)
- Gross weight of trailer must not exceed fifth wheel hitch rating.
- King pin weight must not exceed fifth wheel rating (Figure 3). If in doubt have king pin weight measured by a qualified technician.

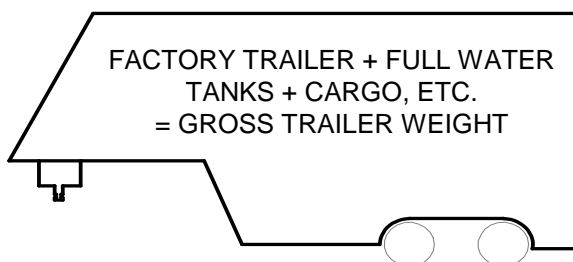

Figure 2

1. Check Tow Ratings:

Vehicle Tow Rating: _____.

Elite Series Hitch Rating: _____.

Gross Trailer Weight (Figure 2): _____.

***Trailer weight should be the lowest of these recorded ratings for safe towing conditions.**

2. Cequent Performance Products hitches are designed for use with recreational fifth wheel trailers only. Hitch applications other than recreational fifth wheel trailers must be approved in writing by Cequent Performance Products' Engineering Department.
3. Use only a SAE 2-inch kingpin with your *Elite Series* Fifth Wheel Hitch.
4. Approximately 15%-25% of trailer weight should be on hitch (Pin Weight)(Figure 3).

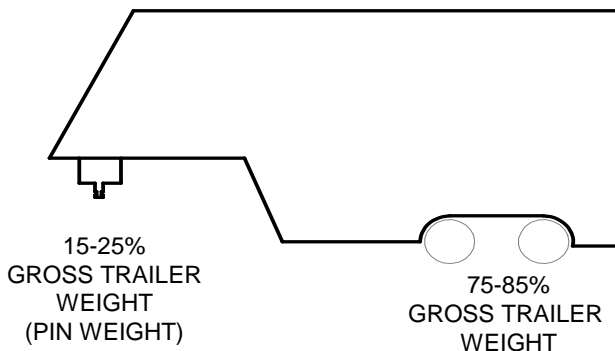
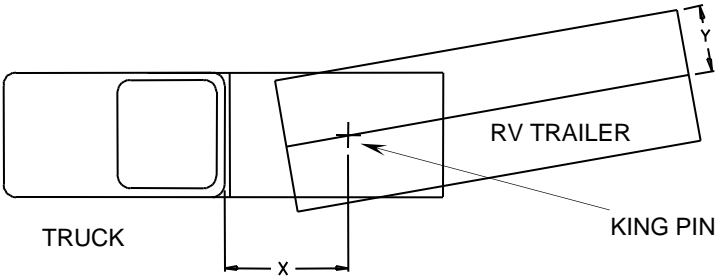

Figure 3

5. Trucks come in many different configurations. Cequent Performance Products' hitches are designed for use in light trucks such as the Ford F-Series, the Chevy Silverado and the Dodge Ram. Cequent Performance Products recommends the use of long bed (8ft) light trucks for the best combination in truck - trailer turning clearance.

Rule of thumb: The distance from the back of the truck cab to the center of the rear truck axle ("X" in **Figure 4**), should be approximately 4 inches greater than one-half the trailer width ("Y" in **Figure 4**).

Figure 4



6. If a short bed pickup (less than 8 ft. but longer than 6 ft.) is to be used for towing, Cequent Performance Products recommends the trailer be equipped with an extended pin box or a **SIDEWINDER** Pinbox Coupler to help gain additional truck - trailer turning clearance (See trailer manufacturer for extended pinbox options or your hitch installer for a **SIDEWINDER** Pinbox Coupler) (**Figure 5**). It also may be helpful to add a *Elite Series* Slider for increased turning clearance for low speed, non-highway maneuvering. If the pickup bed is less than 6 ft., a **SIDEWINDER** Pinbox Coupler **MUST BE INSTALLED ON THE TRAILER**.

Figure 5

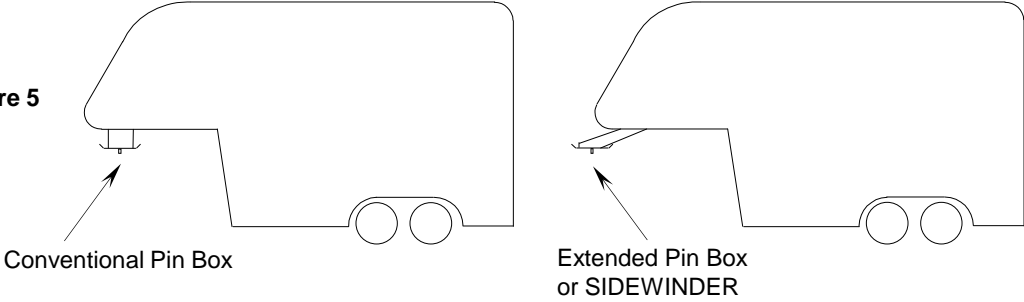

⚠ WARNING:
Do Not install this fifth wheel hitch on or attempt to tow with a short bed pickup truck that has a bed shorter than 6 ft. unless the trailer is equipped with a SIDEWINDER Pinbox Coupler!

7. The height of the hitch and the pin box should be adjusted so the trailer is approximately level as it is towed. Allow approximately 6 inches clearance between the top of the pickup walls and the underside of the front of the trailer for pitch and roll of the trailer. (**Figure 6**). Allow more clearance between pickup walls and trailer for off road use.

Figure 6

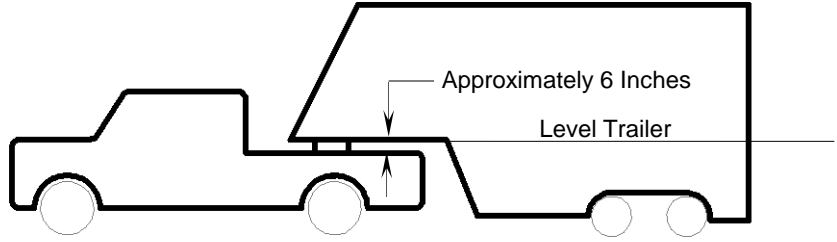

CAUTION:
 The measurements above are guidelines. If your measurements are close to these numbers re-check clearances. If vehicle and/or trailer has any added bed vicinity accessories (i.e. fairings, air dams, ground effects, bed rails, etc.). Additional dimensioning and clearance checks have to be made.

8. Hitch height determination:

With trailer leveled and on level ground measure from the ground to the king pin box ("A" in **Figure 7**). Secondly measure from the height of the inside of the truck bed ("B" in **Figure 7**). Determine the amount of clearance over the side rails ("C" and "D" in **Figure 7**), as mentioned in **Note 7**.

$$\text{Hitch Height} = A - B + 2''$$

The 2" value is an estimate of suspension compression due to king pin weight of the trailer. This compression could range between 1"-5" depending on the truck being used and the trailer being towed.

$$D - C + 2'' > 6'' \text{ as in Note 7.}$$

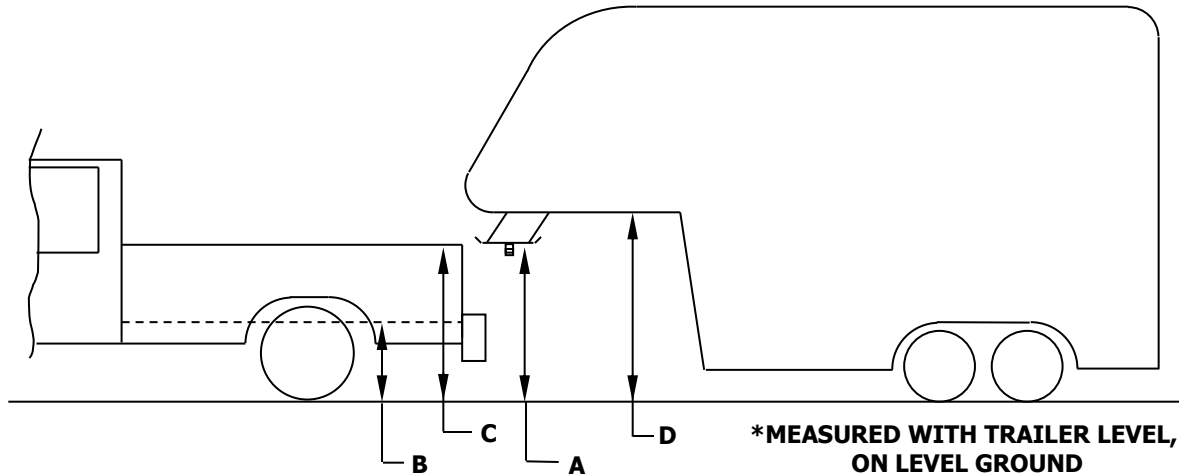

Figure 7

9. If a lube plate is to be used with a *Elite Series 5th* Wheel it must be at least 12" in diameter. Cequent Performance Products offers this optional lube plate as part # 83001 / 40001.

⚠ WARNING:

- Connection for trailer wiring must be located at the side of the truck bed between the driver's seat and the rear wheel to prevent operators from working between the truck and trailer.
- Avoid putting any part of your body under the trailer or between the truck and trailer. Unexpected or accidental movement of the truck or the trailer can cause serious injury or death
- If you must place any part of your body under the trailer or between the truck and trailer you **MUST** perform **ALL** of the following steps:
 - Check that the truck transmission is in park
 - Check that the emergency brake is on
 - Block in front of and behind all trailer tires
 - Check that the trailer landing gear are resting on firm ground

GENERAL INSTRUCTIONS FOR FIFTH WHEEL INSTALLATION

TOOLS

3/16" Drill	15/16" Socket & Open End Wrench
21/32" Drill	200 lb-ft Torque Wrench
3/8" Hex socket	2-1/2" Hole Saw OR 2 1/2" Greenlee Knockout Punch
5/8-11 x 3.5 w/point	

1. The following instructions should be used to mount the 5th wheel. Care and attention to detail will ensure a quick quality installation. Check parts against parts list to become familiar with parts in kit. (**Figure 1**)
2. Raise rear of truck high enough to allow jack stands to be placed under rear spring hanger bracket of truck. This will provide maximum room to install the 5th wheel brackets.



WARNING:

If the truck is raised, be sure that the truck is properly blocked and restrained to prevent the truck from falling. Failure to do so may result in the truck suddenly falling, causing death or serious injury.

3. Plastic drop-in bed liners must be cut out of the way. **Remove plastic bed liner if applicable.** Spray-in bed liners and bed mats less than 1/4" thick will work with normal installation instructions. **Note:** Consult installer for recommended curing time on spray-in liner before cutting holes through bed.

CAUTION:

Check for obstructions before drilling. Failure to do so could result in damaged fuel or brake lines, structural members, etc. CEQUENT PERFORMANCE PRODUCTS does its best to communicate tow vehicle manufacturer changes; however, it is ultimately the responsibility of the installer to prevent damage due to installation.

4. Use only CEQUENT PERFORMANCE PRODUCTS supplied bolts, nuts, and washers to install this kit. All bolts and nuts are grade 8 unless specified otherwise.
5. These instructions are intended for a specific group of trucks. If these instructions do not apply to your vehicle, contact Technical Service to get proper instructions. Each frame bracket must be bolted to the vehicle frame with two bolts.

CAUTION:

These instructions are guidelines only. Actual installation is the responsibility of the installer and the owner. Always measure truck and trailer before installing hitch to be sure that there is clearance at the cab and at the bumper to allow for turns.

6. Trim rear heat shield as seen in **Figure 8**. Reinstall heat shield once mounting kit is in place.

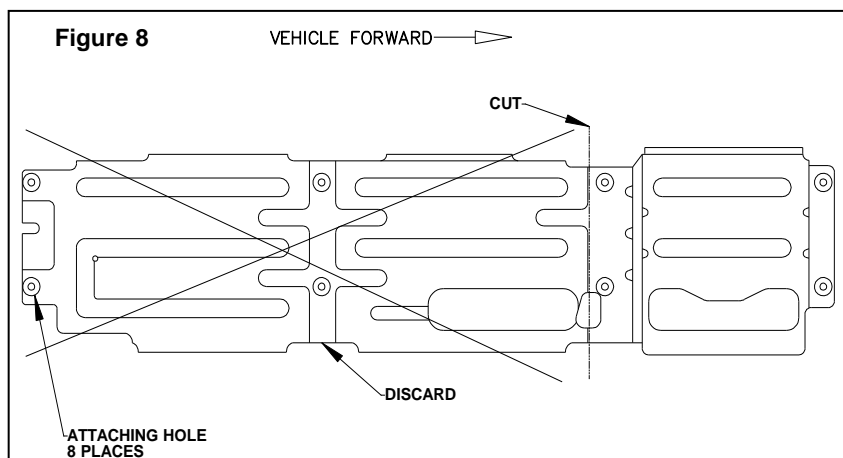

7. Insert rails as shown in the following steps (Figures 9 through 14). With flat side up rear rail (short rail) should be inserted first. With flat side up insert front rail (long rail) second.

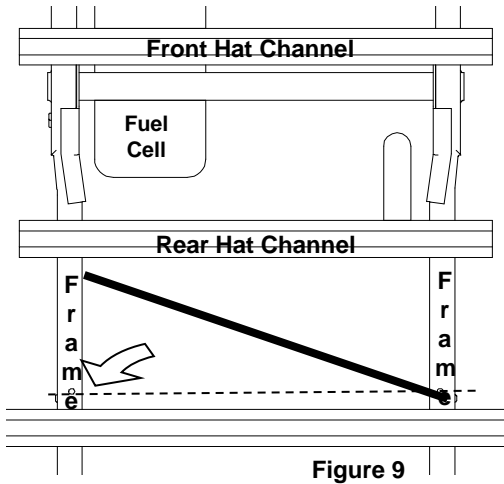
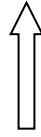

Figure 9



Forward

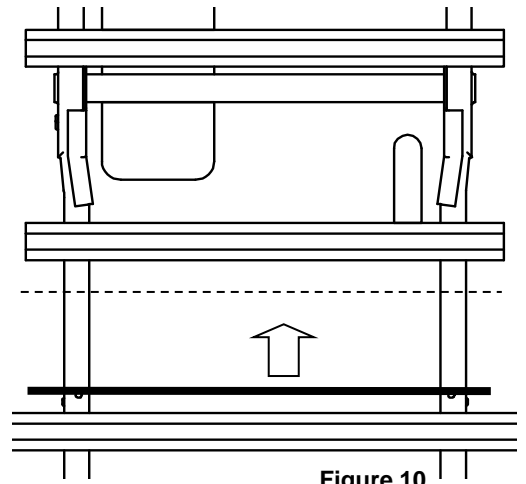

Figure 10

Step 1 : Slide the rear rail (shorter length) in at an angle over the axle. Lift and rotate it so that it rests on the frame (drivers side)

Step 2 : Slide the rail towards the rear hat channel

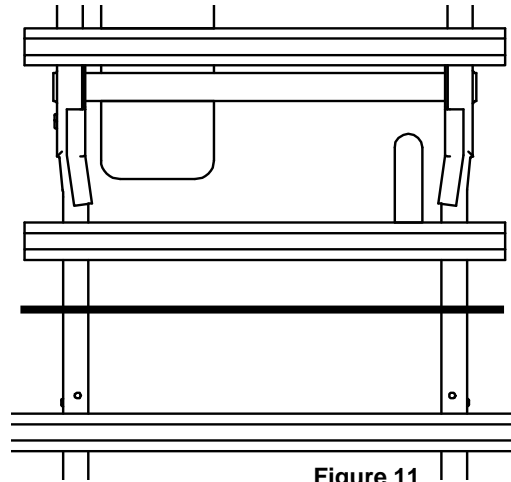

Figure 11

Step 3 : The rail should now be near the rear hat channel with both ends resting evenly on the frame

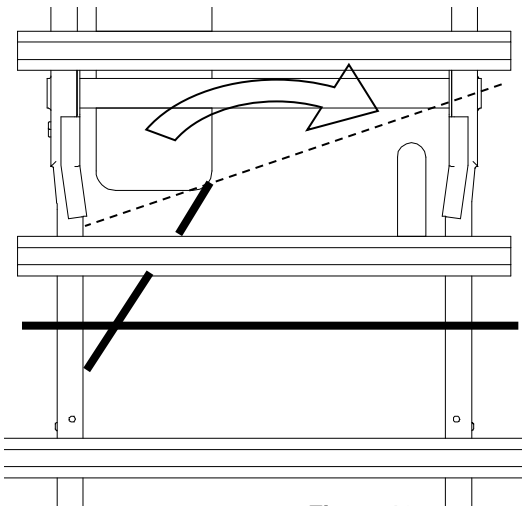
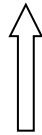

Figure 12



Forward

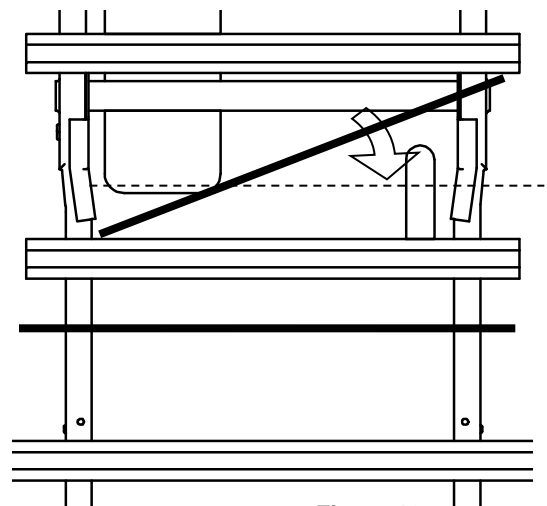

Figure 13

Step 4 : Slide the front rail (longer) in at an angle over the axle, over the exhaust and onto the frame (passenger side)

Step 5 : Lift and rotate the rail over the exhaust and towards the hat channel

↑
Forward

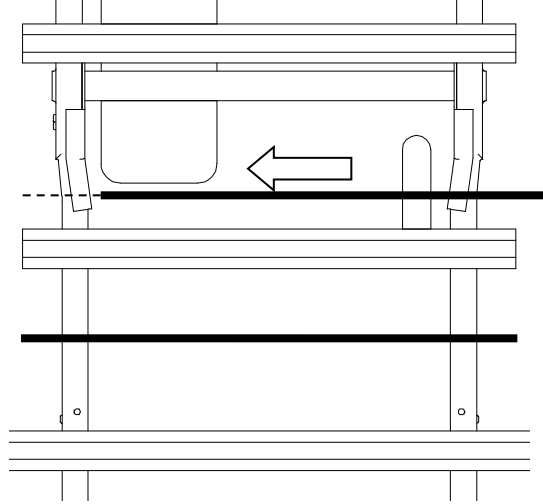
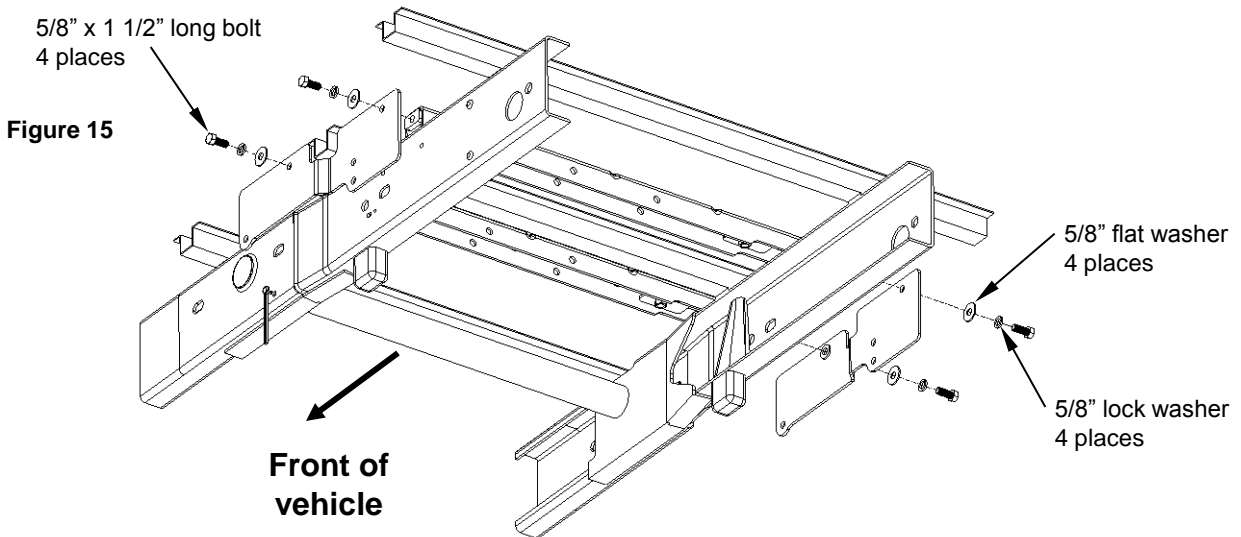

Figure 14

Step 6 : Lift the free end of rail and slide the rail so that it rests evenly on both sides of the frame

8. Loosely attach frame brackets to rails using 5/8" X 1 1/2" long bolts, flat washer & lock washers (Figure 15).



9. Align mounting bracket with holes in chassis frame rail (Figure 16), then loosely attach frame brackets to frame using (3) 5/8" x 2" bolts and (1) 5/8" x 1 1/2" bolt with loc-tite patch on driver side front, spacers, lock washers, and nuts hand tight (Figure 17).

Figure 16

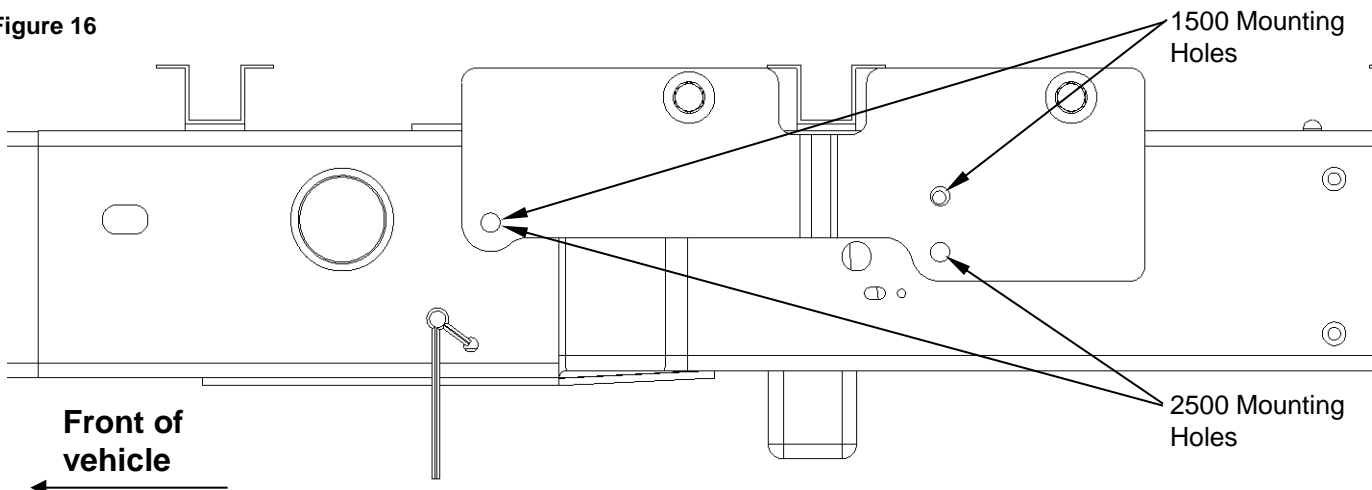

- If access to drilled hole is not possible because of chassis components slide spacer onto bolt and thread bolt into pull wire (**Figure 18**). Guide wire through chassis to drill hole, then pull wire through chassis to position bolt and spacer. Loosely attach lock washer and nut from outside of frame rail.

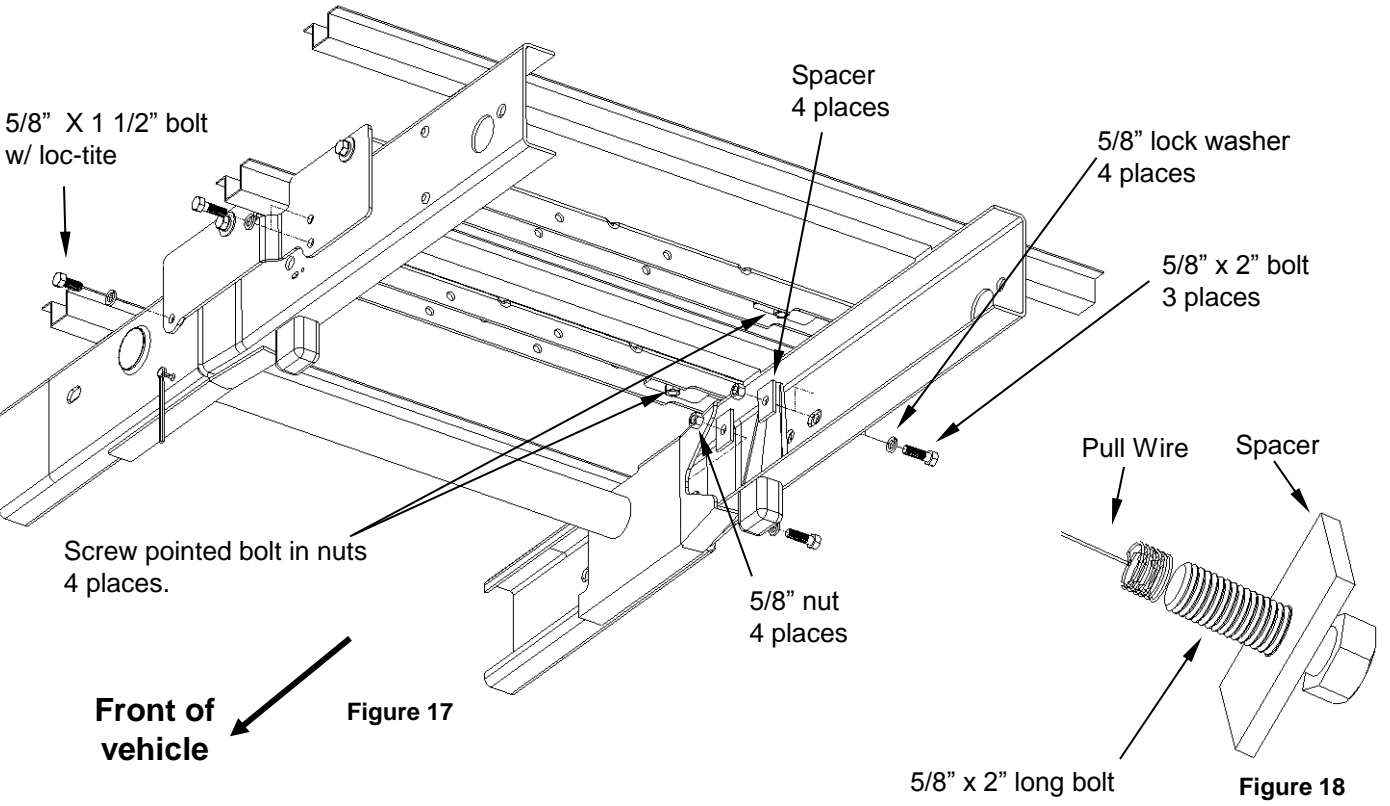

10. Using pointed bolt (**Figure 19**), screw pointed bolt in to the nuts that are welded to the rail assembly to make four prick marks. (**Figure 17**) If a plastic drop in bed liner is being used cut 19" X 4" slots in liner measured from prick marks in truck bed. (**Figure 20**) If the *Elite Series* slider fifth wheel assembly is used, then see fifth wheel slider assembly instructions for slot cut dimensions.

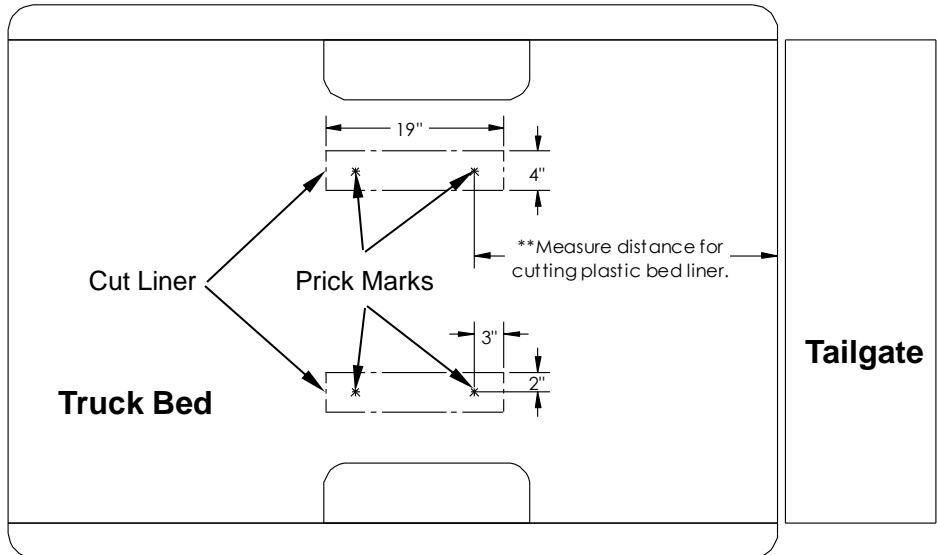
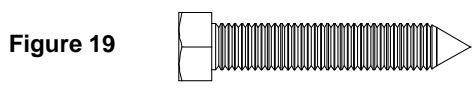

Figure 20

11. Remove 5/8" x 1 1/2" bolts attaching frame bracket to mounting rails. Move rails rearward or forward to prevent interference with hole drilling or punching of the truck bed.

CAUTION:

Check for obstructions before drilling. Failure to do so could result in damaged fuel or brake lines, structural members, etc. CEQUENT PERFORMANCE PRODUCTS does its best to communicate tow vehicle manufacturer changes; however, it is ultimately the responsibility of the installer to prevent damage due to installation.

12. Drill pilot holes in truck bed at prick mark locations. With hole saw or knockout punch create 2 1/2" hole centered at pilot holes. **Note:** Consult installer for recommended curing time on spray-in liner before cutting holes through bed. **Optional:** Spray under coating around 2 1/2" holes to prevent rusting.
13. Loosely reattach rails to frame bracket.
14. From truck bed attach pucks and trim rings to rails (**Figure 21**) using 5/8" button head screw and lock washer. Tighten to 100ft.lbs. torque.

WARNING:
DO NOT lubricate threads. It may cause bolt failure.

Figure 21

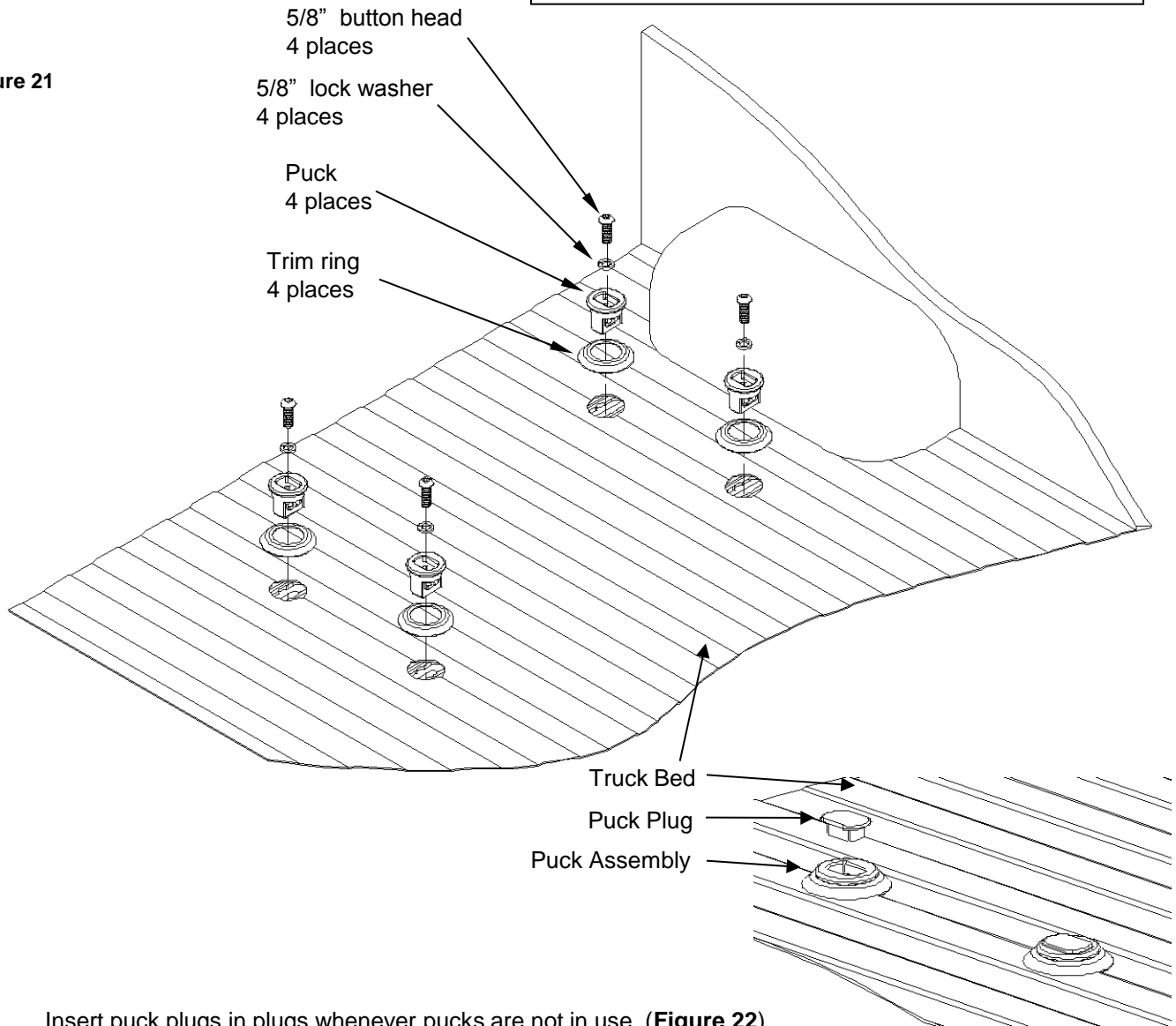

Figure 22

15. Insert puck plugs in plugs whenever pucks are not in use. (**Figure 22**)
16. Install *Elite Series* 5th wheel per hitch assembly instructions.
17. Torque hitch assembly bolts per hitch instructions.
18. Torque all 5/8" rail kit hex bolts to 170ft.lbs
19. Replace any brake lines and spare tire that may have been removed/relocated.